

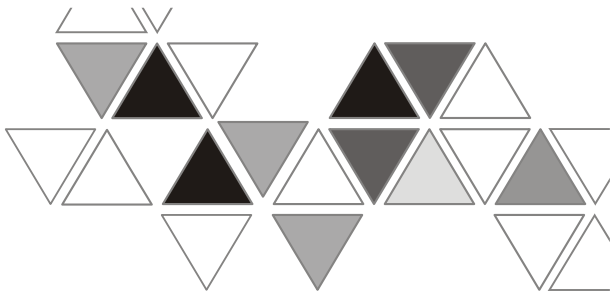

2010-09-24



5012602300-2LC0



DVP02LC-SL

INSTRUCTION SHEET

安裝說明

安装说明

BILGI DÖKÜMANI

- ▲ *Load Cell Module*
- ▲ *Load Cell* 秤重模組
- ▲ *Load Cell* 秤重模块
- ▲ *Load Cell Modülü*



<http://www.delta.com.tw/industrialautomation>

Thank you for choosing Delta's DVP series PLC. Delta releases DVP02LC-SL load cell module of weight measurement function. DVP02LC-SL provides 24-bit resolution applicable for 4-wire or 6-wire load cells with various eigenvalues. Therefore, the response time can be adjusted in coordination with each other according to users' needs. On this basis, the market requirements on weight measurement can easily be met.

- ✦ This instruction sheet provides introductory information on electrical specifications, general specifications, installation and wiring.
- ✦ This is an OPEN TYPE I/O module and therefore should be installed in an enclosure free of airborne dust, humidity, electric shock and vibration. The enclosure should prevent non-maintenance staff from operating the device (e.g. key or specific tools are required to open the enclosure) in case danger and damage on the device may occur.
- ✦ DO NOT connect the input AC power supply to any of the I/O terminals; otherwise serious damage may occur. Check all the wiring again before switching on the power. Make sure the ground terminal (⊕) is correctly grounded in order to prevent electromagnetic interference.
- ✦ The tightening torque for I/O terminal block is 1.95 kg-cm (1.7 in-lbs). Use 60/75°C copper conductors only.

■ Product Profile & Dimensions

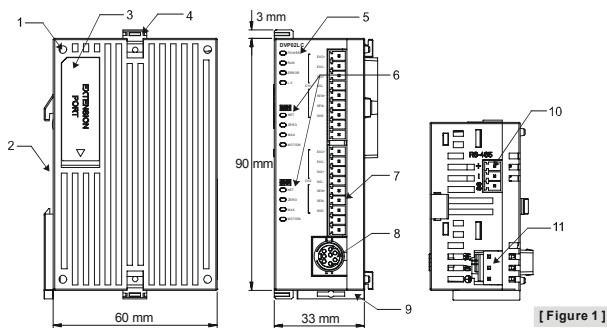

[Figure 1]

1. Mounting hole of the I/O module	2. DIN rail mounting slot (35mm)
3. I/O module connection port	4. I/O module clip
5. Status indicator (POWER, RUN, ERROR and L.V)	6. Function status indicator (NET, ZERO, MAX, MOTION)
7. I/O terminals	8. RS-232 port
9. Mounting slot clip	10. RS-485 port
11. DC power input	

■ I/O Terminal Layout

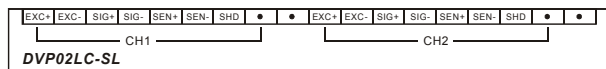

External Wiring

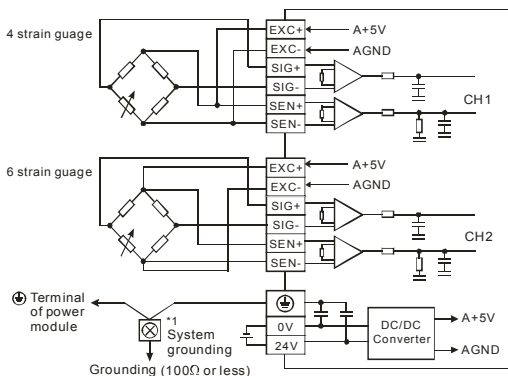

[Figure 2]

Note 1: Please connect the \oplus terminal on both the power module and Load Cell module to the system earth point and ground the system contact or connect it to the cover of power distribution cabinet.

Electrical Specifications

Load cell module	Voltage output
Rated power supply voltage/ power consumption	24 VDC (-15 to +20%) / 3W
Voltage Boundary	18 to 31.2 VDC
Max. current consumption	125 mA
Input signal range	± 40 mVDC
Sensibility	+5 VDC +/-10%
Internal resolution	24 bits
Communication port	RS-232, RS-485
Applicable sensor type	4-wire or 6-wire strain gauge
Temperature coefficient span	$\leq \pm 50$ ppm/K v. E
Temperature coefficient zero point	$\leq \pm 0.4$ μ V/K
Linearity error	$\leq 0.02\%$
Response time	2, 10, 20, 40, 80 ms \times channels
4 measuring ranges	0 to 1 mV/V, 0 to 2 mV/V, 0 to 4 mV/V, 0 to 6mV/V
Max. distance for connecting to load cell	100 M
Max. current output	5 VDC * 300 mA
Permitted load cell resistance	40 to 4,010 Ω
Common mode rejection (CMRR @50/60 Hz)	≥ 100 dB
Dynamic value filter	Setting range: K1 to K5
Average value filter	Setting range: K1 to K100
Isolation method	500 VAC between digital circuits and Ground 500 VAC between analog circuits and Ground 500 VAC between analog circuits and digital circuits

Load cell module	Voltage output
Series connection to DVP-PLC MPU	Connectable to the left side of MPU, numbered from 100 to 107 according to the position of module from the closest to farthest to MPU.
Operation / storage temperature	Operation: 0 to 55°C (temp.), 50 to 95% (humidity), pollution degree 2 Storage: -25 to 70°C (temp.), 5 to 95% (humidity)
Vibration / shock immunity	International standards: IEC61131-2, IEC 68-2-6 (TEST Fc)/ IEC61131-2 & IEC 68-2-27 (TEST Ea)

- ❖ Complying with DIN1319-1, the tolerance of measured value should be $\leq 0.05\%$ under 20°C + 10K temperature range.
- ❖ When the corrected ambient temperature and the actual temperature have a difference of more than 10°C, it is suggested that you re-correct it.

■ Control Register

CR#	Add.	Attrib.		Register name	Explanation
#0	H1000	O	R	Model name	Set up by the system: DVP02LC-SL model code = H'4206
#1	H1001	O	R	Firmware version	Display the current firmware version in hex.
#2	H1002	O	R/W	Characteristic value	Mode 0 (H'0000): 1 mV/V Mode 1 (H'0001): 2 mV/V, default Mode 2 (H'0002): 4 mV/V Mode 3 (H'0003): 6 mV/V
#3	H1003	O	R/W	Reaction time for measurement	Mode 0 (H'0000): 2 ms Mode 1 (H'0001): 10 ms Mode 2 (H'0002): 20 ms Mode 3 (H'0003): 40 ms Mode 4 (H'0004): 80 ms, default
#4	H1004	O	R	Average value of all channels	Sum up CH1 average value and CH2 average value and equalize them. Equation: (CH1 average value + CH2 average value)/2
#6	H1006	X	R/W	CH1 to CH2 read tare weight	Read present average value as tare weight value bit0: CH1; bit1: CH2; bit2 to bit15: reserved
#7	H1007	O	R/W	CH1 to CH2 gross/net weight	Display present weight as Gross (K0) or Net (K1). bit0 to bit3: CH1; bit4 to bit7: CH2; bit8 to bit15: reserved. Take CH1 for example: bit3 to bit0 = 0000, gross; bit3 to bit0 = 0001, net; bit3 to bit0 = 1111, channel disabled.
#8	H1008	O	R/W	CH1 tare weight	The user can write in the weight or read it by commands. Default: K0; Range: -K32,768 to K32,767.
#9	H1009	O	R/W	CH2 tare weight	
#10	H100A	O	R/W	CH1 average times	Default: K10; Range: K1 to K100. When the set value exceeds the range, it will automatically be changed to K1 or K100.
#11	H100B	O	R/W	CH2 average times	
#12	H100C	X	R	CH1 average weight	Display average weight.
#13	H100D	X	R	CH2 average weight	
#14	H100E	X	R	CH1 present weight	Display present weight.
#15	H100F	X	R	CH2 present weight	
#16	H1010	O	R/W	CH1 standstill times	Default: K5 Range: K1 to K500
#17	H1011	O	R/W	CH2 standstill times	

CR#	Add.	Attrib.		Register name	Explanation
#18	H1012	O	R/W	CH1 standstill range	Default: K10
#19	H1013	O	R/W	CH2 standstill range	Range: K1 to K10,000
#20	H1014	O	R/W	CH1 decimal place	Default: K2
#21	H1015	O	R/W	CH2 decimal place	Range: K1 to K4
#22	H1016	O	R/W	CH1 unit of measurement	Enter max. 4 ASCII words. CR#22, CR#24: High word CR#23, CR#25: Low word
#23	H1017	O	R/W	CH1 unit of measurement	
#24	H1018	O	R/W	CH2 unit of measurement	
#25	H1019	O	R/W	CH2 unit of measurement	
#26	H101A	X	R/W	Weight correction command	For the user to correct the weight. Default: H'0000 H'0001: CH1 Reset to zero command H'0002: CH1 Weight base point command H'0003: CH2 Reset to zero command H'0004: CH2 Weight base point command
#33	H1021	O	R/W	CH1 weight base point	For CR#33 to CR#34 default = K1,000; Range: K-32,768 to K32,767 Steps for correction: Take CH1 for example 1: Place no weights on the load cell 2: Set up CR#26 command = "H'0001" 3: Place standard weights on load cell 4: Write the weight of the weights on the plate into CR#33. 5: Set up CR#26 command = "H'0002"
#34	H1022	O	R/W	CH2 weight base point	
#35	H1023	O	R	CH1 max. weight	Set up the max. weight. When the measured value exceeds the set value, error codes will be recorded.
#36	H1024	O	R	CH2 max. weight	
#37	H1025	O	R/W	Upper limit for CH1 zero point check	Reference for reset to zero. When the weight is within this range, the status code will be set to "zero bit", indicating the current zero weight status.
#38	H1026	O	R/W	Upper limit for CH2 zero point check	Default: K10 Range: K-32,768 to K32,767
#39	H1027	O	R/W	Lower limit for CH1 zero point check	Reference for reset to zero. When the weight is within this range, the status code will be set to "zero bit", indicating the current zero weight status.
#40	H1028	O	R/W	Lower limit for CH2 zero point check	Default: K-10 Range: K-32,768 to K32,767
#41	H1029	X	R/W	Saving set value (H'5678)	Save the present set value and write all the set values into the internal Flash for use next time DVP02LC-SL is switched on. H0: No action, Default H'FFFF: Saving is successful H'5678: Write to internal Flash When H'5678 is written in, all set values will be saved in Flash. When the saving is completed, CR#41 will become H'FFFF. If the value written in is not H'5678, it will automatically return to H0, e.g. write K1 into CR# to return to K0.

CR#	Add.	Attrib.	Register name	Explanation
#43	H102B	X R/W	CH1 filter percentage	Default: K2 Range: K1 to K5 (Unit: 10%)
#44	H102C	X R/W	CH2 filter percentage	
#45	H102D	X R/W	CH1 filter average value	Display average weight after filtering. Condition to enable filter: average time ≥ 30
#46	H102E	X R/W	CH2 filter average value	
#50	H1032	X R	Status code	b0 (H'0001): CH1 zero weight (empty) b1 (H'0002): CH2 zero weight (empty) b2 (H'0004): CH1 exceeds max. weight (overload) b3 (H'0008): CH2 exceeds max. weight (overload) b4 (H'0010): CH1 stable measured value b5 (H'0020): CH2 stable measured value b6 ~ b15: Reserved
#51	H1033	X R	Error code	Store all the error statuses. See "Error Code Table" below. Default: H'0000
#52	H1034	O R/W	RS-232 node address	For CR#52, CR#54 default = 1 Range: K1 to K255 For CR#53, CR#55 default = H'0000; Range: ASCII, 9600, 7, E, 1. See "Communication Format Table" below.
#53	H1035	O R/W	RS-232 communication setting	
#54	H1036	O R/W	RS-485 node address	
#55	H1037	O R/W	RS-485 communication setting	
Symbols: O means latched. X means not latched. R means can read data. W means can write data.				

▲ Error Code Table for CR#51:

bit	Content	Error	bit	Content	Error
b0	K1 (H'0001)	Power supply abnormality	b1	K2 (H'0002)	Hardware abnormality
b2	K4 (H'0004)	CH1 conversion error	b3	K8 (H'0008)	CH1 SEN voltage error
b4	K16 (H'0010)	CH2 conversion error	b5	K32 (H'0020)	CH2 SEN voltage error
b6 ~ b15	K64 (H'0040)	Reserved			
Note: Every error status is decided by its corresponding bit, so there might be more than 2 error statuses occurring at the same time. 0 refers to no error; 1 refers to error occurring.					

▲ Communication Format Table for CR#53, CR#55:

bit15	bit14~bit8	bit7	bit6	bit5	bit4	bit3	bit2	bit1	bit0
ACSII/RTU	Reserved	Baudrate			Data length	Stop bit	Parity		
Description									
bit15	ACSII/RTU			0	ASCII	1	RTU		
bit7~bit4	Baudrate	0	9,600 bps		1	19,200 bps			
		2	38,400 bps		3	57,600 bps			
		4	115,200 bps		5	Else none			
bit3	Data length (RTU = 8 bits)			0	7	1	8		
bit2	Stop bit			0	1 bit	1	2 bits		
bit1~bit0	Parity	0	Even		1	Odd			
		2	None		3	None			