



## Industrial Automation Headquarters

**Taiwan: Delta Electronics, Inc.**  
Taoyuan Technology Center  
No.18, Xinglong Rd., Taoyuan District,  
Taoyuan City 330477, Taiwan  
TEL: +886-3-362-6301 / FAX: +886-3-371-6301

## Asia

**China: Delta Electronics (Shanghai) Co., Ltd.**  
No.182 Minyu Rd., Pudong Shanghai, P.R.C.  
Post code : 201209  
TEL: +86-21-6872-3988 / FAX: +86-21-6872-3996  
Customer Service: 400-820-9595

**Japan: Delta Electronics (Japan), Inc.**  
Industrial Automation Sales Department  
2-1-14 Shibadaimon, Minato-ku  
Tokyo, Japan 105-0012  
TEL: +81-3-5733-1155 / FAX: +81-3-5733-1255

**Korea: Delta Electronics (Korea), Inc.**  
1511, 219, Gasan Digital 1-Ro., Geumcheon-gu,  
Seoul, 08501 South Korea  
TEL: +82-2-515-5305 / FAX: +82-2-515-5302

**Singapore: Delta Energy Systems (Singapore) Pte Ltd.**  
4 Kaki Bukit Avenue 1, #05-04, Singapore 417939  
TEL: +65-6747-5155 / FAX: +65-6744-9228

**India: Delta Electronics (India) Pvt. Ltd.**  
Plot No.43, Sector 35, HSIIDC Gurgaon,  
PIN 122001, Haryana, India  
TEL: +91-124-4874900 / FAX: +91-124-4874945

**Thailand: Delta Electronics (Thailand) PCL.**  
909 Soi 9, Moo 4, Bangpoo Industrial Estate (E.P.Z),  
Pattana 1 Rd., T.Phraksa, A.Muang,  
Samutprakarn 10280, Thailand  
TEL: +66-2709-2800 / FAX: +66-2709-2827

**Australia: Delta Electronics (Australia) Pty Ltd.**  
Unit 2, Building A, 18-24 Ricketts Road,  
Mount Waverley, Victoria 3149 Australia  
Mail: IA.au@deltaww.com  
TEL: +61-1300-335-823 / +61-3-9543-3720

## Americas

**USA: Delta Electronics (Americas) Ltd.**  
5101 Davis Drive, Research Triangle Park, NC 27709, U.S.A.  
TEL: +1-919-767-3813 / FAX: +1-919-767-3969

**Brazil: Delta Electronics Brazil Ltd.**  
Estrada Velha Rio-São Paulo, 5300 Eugênio de  
Melo - São José dos Campos CEP: 12247-004 - SP - Brazil  
TEL: +55-12-3932-2300 / FAX: +55-12-3932-237

**Mexico: Delta Electronics International Mexico S.A. de C.V.**  
Gustavo Baz No. 309 Edificio E PB 103  
Colonia La Loma, CP 54060  
Tlalnepantla, Estado de México  
TEL: +52-55-3603-9200

## EMEA

**EMEA Headquarters: Delta Electronics (Netherlands) B.V.**  
Sales: Sales.IA.EMEA@deltaww.com  
Marketing: Marketing.IA.EMEA@deltaww.com  
Technical Support: iatechnicalsupport@deltaww.com  
Customer Support: Customer-Support@deltaww.com  
Service: Service.IA.emea@deltaww.com  
TEL: +31(0)40 800 3900

**BENELUX: Delta Electronics (Netherlands) B.V.**  
Automotive Campus 260, 5708 JZ Helmond, The Netherlands Mail:  
Sales.IA.Benelux@deltaww.com  
TEL: +31(0)40 800 3900

**DACH: Delta Electronics (Netherlands) B.V.**  
Coesterweg 45, D-59494 Soest, Germany  
Mail: Sales.IA.DACH@deltaww.com  
TEL: +49 2921 987 238

**France: Delta Electronics (France) S.A.**  
ZI du bois Challand 2, 15 rue des Pyrénées,  
Lisses, 91090 Evry Cedex, France  
Mail: Sales.IA.FR@deltaww.com  
TEL: +33(0)1 69 77 82 60

**Iberia: Delta Electronics Solutions (Spain) S.L.U**  
Ctra. De Villaverde a Valleccas, 265 1º Dcha Ed.  
Hormigueras - P.I. de Valleccas 28031 Madrid  
TEL: +34(0)91 223 74 20  
Carrer Llacuna 166, 08018 Barcelona, Spain  
Mail: Sales.IA.Iberia@deltaww.com

**Italy: Delta Electronics (Italy) S.r.l.**  
Via Meda 2-22060 Novedrate(CO)  
Piazza Grazioli 18 00186 Roma Italy  
Mail: Sales.IA.Italy@deltaww.com  
TEL: +39 039 8900365

**Turkey: Delta Greentech Elektronik San. Ltd. Sti.(Turkey)**  
Şerifali Mah. Hendem Cad. Kule Sok. No:16-A  
34775 Ümraniye - İstanbul  
Mail: Sales.IA.Turkey@deltaww.com  
TEL: + 90 216 499 9910

**MEA: Eltek Dubai (Eltek MEA DMCC)**  
OFFICE 2504, 25th Floor, Saba Tower 1,  
Jumeirah Lakes Towers, Dubai, UAE  
Mail: Sales.IA.MEA@deltaww.com  
TEL: +971(0)4 2690148

# Delta ASDA-A3 Series Servo Drive User Manual



## Delta ASDA-A3 Series Servo Drive User Manual

www.deltaww.com



# Preface

---

Thank you for purchasing this product. This manual provides information about the ASDA-A3 series servo drives (A3) and the applicable servo motors.

This manual includes:

- Installation and inspection of servo drive and servo motor
- Servo structure and wiring diagram
- Instructions for test operation
- Instructions for servo tuning
- Description of parameters
- Description of communication protocol
- Troubleshooting
- Inspection and maintenance

ASDA-A3 product features:

Delta has developed a new control algorithm that enables you to easily overcome the problems of a lack of stiffness or flexibility in the machine structure. The new automatic tuning function is more user-friendly and allows you to complete tuning easily. In addition, you can also utilize the gain adjustment function to improve the performance of the drive. Its compact design can reduce the space required inside the cabinet. The smaller design of the new generation of the ECM-A3 series servo motor can also meet the need to reduce equipment structures' size and weight.

How to use this manual:

Use this manual as a reference when installing, setting up, using, and maintaining the servo drive. Before initiating the tuning or setup process, read Chapters 1 to 5. You can also use the Table of Contents and the Index to quickly locate the information you need.

DELTA technical services:

Please consult your DELTA equipment distributor or DELTA Customer Service Center if you encounter any problems.

## Safety Precautions

The ASDA-A3 is a high-resolution open type servo drive. It should be installed in a shielded control box during operation. This product uses precise feedback control and a digital signal processor (DSP) with high-speed calculation functions to control the current output generated by IGBT to operate three-phase permanent magnet synchronous motors (PMSM) and to achieve precise positioning.

The ASDA-A3 series are used in industrial applications and should be installed in the control box. Servo drives, wires, and motors should all be installed in an environment which complies with the minimum requirement of UL50 Type 1.

Pay special attention to the following safety precautions at all times during inspection, installation, wiring, operation, maintenance, and examination of the servo drive.

The symbols of “DANGER”, “WARNING”, and “STOP” indicate:



**Danger. May cause severe or fatal injuries to personnel if the instructions are not followed.**



**Warning. May cause moderate injury to personnel, or lead to severe damage or even malfunction of the product if the instructions are not followed.**



**Absolutely prohibited activities. May cause serious damage or even malfunction of the product if the instructions are not followed.**

### Inspection



Please follow the instructions when using the A3 servo drive and servo motor, or it may cause fire or malfunction.

### Installation



Do not expose the product to an environment containing vapor, corrosive gas, inflammable gas, or other foreign matter to reduce the risk of electric shock or fire.

### Wiring



- Connect the ground terminals to class-3 ground system. Ground resistance should not exceed 100  $\Omega$ . Improper grounding may result in electric shock or fire.
- Do not connect the three-phase source to the motor output terminals U, V, and W, or it may cause personnel injury or fire.
- Tighten the screws of the power and motor output terminals, or it may cause fire.
- When wiring, refer to the description of wire selection in Chapter 3 to prevent any danger.

## Operation



- Before operating the machine, change the servo parameter setting according to the application. If the parameters are not adjusted to the correct values, it may lead to malfunction of the machine or the operation might be out of control.
- Ensure you can activate the emergency stop before operating the machine.
- When applying power, make sure the motor is not rotating because of inertia of the machine or other causes.



During the operation, do not touch any rotating motor parts, or it may cause personnel injury.



- To avoid accidents, remove all units during the first test run, so that the motor is operating without any load.
- If you fail to operate the servo motor properly after it is connected to the equipment, it may damage the equipment and lead to personnel injury.
- In order to prevent danger, it is strongly recommended that you check if the servo motor can operate normally without load first. Then, try operating the motor with load.
- Do not touch the heat sink of the servo drive during operation, or it may cause burns.

## Maintenance and inspection



- Do not touch the internal parts of the servo drive and servo motor, or it may cause electric shock.
- Do not disassemble the servo drive panel when the power is on, or it may cause electric shock.
- Do not touch the ground terminal within 10 minutes after turning off the power, or the residual voltage may cause electric shock.
- Do not disassemble the motor, or it may cause electric shock or personnel injury.
- Do not change the wiring when the power is on, or it may cause electric shock or personnel injury.
- Only qualified electricians can install, wire, and maintain the servo drive and servo motor.



## Main circuit wiring



- Do not put the power cable and signal cable in the same channel or bond them together. Separate the power cable and signal cable by at least 30 centimeters (11.8 inches).
- Please use stranded wires and multi-core shielded-pair wires for signal cables and encoder feedback cables. The maximum length of the signal input cable is 3 meters (9.84 feet) and the maximum length of the feedback cable is 20 meters (65.62 feet).
- The high voltage may remain in the servo drive immediately after the power is turned off. Please wait for 10 minutes before touching the terminals.



Do not repeatedly turn the power on and off. If continuous power on and off is needed, wait one minute between intervals.

## Terminal wiring of the main circuit



- When wiring, remove the terminal blocks from the servo drive.
- Insert only one electric wire per terminal socket.
- When inserting the electric wires, do not short circuit the adjacent conductors.
- Before applying power, please inspect and ensure that the wiring is correct.

## Leakage current



- The leakage current of the servo drive is greater than 3.5 mA.
- According to the IEC 61800-5-1 standards, the wires must comply with one of the following specifications to ensure proper grounding:
  1. Copper wire cross-sectional area is at least 10 mm<sup>2</sup>.
  2. Aluminum wire cross-sectional area is at least 16 mm<sup>2</sup>.
- Failure to comply with the specifications may result in personnel injury.
- Before applying power, inspect and ensure that the wiring is correct.

## Disposal instructions



- When disposing of the product, make sure it is disposed of as general industrial waste in accordance with the local laws and regulations.

## Inspection and maintenance

Operating conditions:

- Average annual ambient temperature: 30°C (86°F)
- Average load rate: 80% or less
- Average operating time: 20 hours per day

Inspection frequency	Inspection item
Daily inspection	Check if the ambient temperature and humidity are normal.
	Check if the input voltage is normal.
	Check if there is abnormal vibration and noise.
	Check if there is any abnormal smell.
	Check if the servo drive has any visible damage.
	Check if the ventilation holes are kept clear of dust and other foreign objects. *1
	Check if the wirings are damaged or disconnected.
Annual inspection	Check if any cable is loose or damaged.
	Check if any screw is loose or damaged.
	Check if the servo drive, motor, and control cabinet are properly grounded.
	Check if the color and temperature of the power input, power output, and regenerative terminals are normal. *2

Note:

1. Install dust filters on the control cabinet openings, where there are fans or ventilation holes, and clean the filters regularly. Install door seals on cabinet doors and rubber grommets on cable openings for better seal.
2. Check if the servo drive is properly wired. If the color of any terminal turns black or is abnormal, it is suggested that you replace the terminal.

## Replacing the parts

Operating conditions:

- Average annual ambient temperature: 30°C (86°F)
- Average load rate: 80% or less
- Average operating time: 20 hours per day

Product	Part name	Suggested replacement cycle	Note
Servo drive	Electrolytic capacitor	Approx. 5 years	The replacement cycle varies depending on the ambient conditions and usage. Replace the part immediately when any error occurs.
	Cooling fan	2 to 3 years (10,000 to 30,000 hours)	
	Relay	Approx. 100,000 times	
	Soft start resistor	Approx. 20,000 times	
Battery box	Battery	Refer to Section 10.1.1.	
Servo motor	Bearing	20,000 hours	
	Oil seal	5,000 hours	



- When the part reaches the suggested replacement cycle, consult the distributor or Delta for replacement suggestions.
- Do not attempt to disassemble or repair the product yourself.

Note: the content of this manual may be revised without prior notice. Refer to the latest information from [Delta's website](#).

# Table of Contents

---

## Before Operation

### 1

#### Product Overview

1.1	Items to check after unpacking .....	1-2
1.2	Model overview.....	1-3
1.2.1	Nameplate information .....	1-3
1.2.2	Model explanation .....	1-5
1.3	ASDA-A3 servo drive and motor.....	1-11
1.3.1	220V models.....	1-11
1.3.2	400V models.....	1-14
1.4	Description of the drive interface.....	1-15
1.4.1	220V models: A3-L .....	1-15
1.4.2	220V models: A3-M .....	1-16
1.4.3	220V models: A3-F.....	1-17
1.4.4	220V models: A3-E.....	1-18
1.4.5	400V models: A3-L .....	1-19
1.4.6	400V models: A3-M .....	1-20
1.4.7	400V models: A3-F.....	1-21
1.4.8	400V models: A3-E.....	1-22

### 2

#### Installation

2.1	Ambient storage conditions .....	2-2
2.2	Ambient installation conditions .....	2-2
2.3	Mounting direction and space .....	2-5
2.4	Safety precautions for using motors .....	2-8
2.4.1	Troubleshooting for the motor operation and status .....	2-10
2.4.2	Mounting directions and precautions for the servo motor.....	2-11
2.4.3	Precautions for using servo motor with oil seal.....	2-12
2.4.4	Precautions for installing servo motor accessories.....	2-13
2.4.5	Oil and water prevention measures for the servo motor .....	2-15
2.4.6	Measures to suppress temperature increase of the servo motor .....	2-16
2.5	Specifications for the circuit breaker, magnetic contactor and fuse .....	2-17
2.6	Ferrite ring.....	2-20
2.7	Installation requirements for EMC .....	2-22

2.7.1	EMI filters .....	2-24
2.8	Selecting the regenerative resistor .....	2-26
2.9	The use of braking.....	2-34
2.10	The use of cable.....	2-36

# 3

## Wiring

3.1	220V series servo system connection .....	3-4
3.1.1	Connecting to peripheral devices (connecting to Delta communication type servo motor) .....	3-4
3.1.2	Connectors and terminals .....	3-6
3.1.3	Wiring for power supply .....	3-8
3.1.4	UVW power connector specifications.....	3-11
3.1.4.1	F40 - F80 motors – Power connectors .....	3-12
3.1.4.2	F100 - F130 motors – Power connectors .....	3-15
3.1.4.3	F180 4.5 kW (or below) motors – Power connectors .....	3-18
3.1.4.4	F180 5.5 kW (or above) & F220 motors – Power connectors .....	3-21
3.1.5	Encoder cable and connector specifications.....	3-23
3.1.5.1	F40 - F80 motors – Encoder connectors.....	3-23
3.1.5.2	F100 - F180 ECMC motors – Encoder connectors.....	3-30
3.1.5.3	F100 - F220 ECM-B3 motors – Encoder connectors .....	3-33
3.1.6	Wire selection.....	3-39
3.1.6.1	Wire diameters and terminals / ferrules .....	3-39
3.1.6.2	Crimping the wire ferrules .....	3-40
3.1.6.3	Screw terminal block dimensions / screw and tightening torque specifications .....	3-42
3.1.6.4	Encoder cable specifications .....	3-43
3.1.6.5	Power cable specifications .....	3-44
	Motor frame: F40 - F80 .....	3-44
	Motor frame: F100 - F130.....	3-45
	Motor frame and power: F180 4.5 kW (or below) .....	3-46
	Motor frame and power: F180 5.5 kW (or above) & F220.....	3-47
3.1.6.6	Flexible cable specifications .....	3-48
3.1.7	Waterproof connector wiring instructions .....	3-49
3.1.7.1	F40 - F80 models – power / encoder / brake connector .....	3-49
	CHOGORI connector.....	3-49
	Bulkhead connector .....	3-50
3.1.7.2	F100 - F180 models (4.5 kW or below) – power connector.....	3-52
3.1.7.3	Waterproof connector specifications .....	3-53
3.2	400V series servo system connection .....	3-54
3.2.1	Connecting to peripheral devices (connecting to Delta communication type	

servo motor) .....	3-54
3.2.2 Connectors and terminals .....	3-56
3.2.3 Wiring for power supply .....	3-58
3.2.4 UVW power connector specifications.....	3-59
3.2.4.1 F40 - F80 motors – Power connectors .....	3-59
3.2.4.2 F100 - F130 motors – Power connectors .....	3-59
3.2.4.3 F180 4.5 kW (or below) motors – Power connectors .....	3-59
3.2.4.4 F180 5.5 kW (or above) & F220 motors – Power connectors .....	3-59
3.2.5 Encoder cable and connector specifications.....	3-60
3.2.5.1 F40 - F80 motors – Encoder connectors.....	3-60
3.2.5.2 F100 - F220 ECM-B3 motors – Encoder connectors .....	3-61
3.2.6 Wire selection.....	3-62
3.2.6.1 Wire diameters and terminals / ferrules .....	3-62
3.2.6.2 Screw terminal block dimensions / screw and tightening torque specifications .....	3-63
3.2.6.3 Cable specifications.....	3-64
3.2.6.4 Waterproof connector specifications .....	3-64
3.3 Servo system wiring diagram .....	3-65
3.3.1 220V series models .....	3-65
400 W (and below) models .....	3-65
750 W - 3 kW models .....	3-66
4.5 kW - 15 kW models .....	3-67
3.3.2 400V series models .....	3-68
400 W - 1.5 kW models .....	3-68
2 kW - 15 kW models.....	3-69
3.4 Wiring for CN1 I/O connector .....	3-70
3.4.1 A3-L and A3-M models – Wiring for CN1 I/O connector.....	3-70
3.4.1.1 A3-L and A3-M models – CN1 I/O connector .....	3-70
3.4.1.2 A3-L and A3-M models – Quick connector .....	3-77
3.4.1.3 A3-L and A3-M models – CN1 wiring diagrams .....	3-82
3.4.2 A3-E and A3-F models – Wiring for CN1 I/O connector.....	3-89
3.4.2.1 A3-E and A3-F models – CN1 I/O connector .....	3-89
3.4.2.2 A3-E and A3-F models – Quick connector .....	3-95
3.4.2.3 A3-E and A3-F models – CN1 wiring diagrams .....	3-99
3.5 Wiring for the CN2 encoder connector .....	3-102
3.6 Wiring for the CN3 connector (RS-485 / high-speed communication).....	3-107
3.7 Wiring for CN4 connector (Mini USB).....	3-109
3.8 Wiring for CN5 connector (applicable to full-closed loop).....	3-110
3.9 Wiring for CN6 connector.....	3-112
3.9.1 Wiring for the DMCNET communication connector .....	3-112



3.9.2	Wiring for the EtherCAT communication connector .....	3-114
3.10	CN10 STO (Safe Torque Off) function .....	3-117
3.10.1	Introduction to STO .....	3-117
3.10.2	Precautions for using STO function .....	3-117
3.10.3	Potential risks of STO .....	3-118
3.10.4	Safety parameters .....	3-119
3.10.5	How does the STO function work? .....	3-120
3.10.5.1	Response time .....	3-120
3.10.5.2	Alarm triggering .....	3-121
3.10.5.3	STO deactivation settings .....	3-123
3.10.6	Wiring for STO .....	3-128
3.10.6.1	CN10 STO connector .....	3-128
3.10.6.2	Input / output signal specification .....	3-129
3.10.6.3	Not using the STO function .....	3-130
3.10.6.4	Using the STO function for a single drive .....	3-130
3.10.6.5	Using the STO function for multiple drives .....	3-131
3.10.7	Validation test .....	3-132
3.11	220V series – Standard wiring example .....	3-133
3.11.1	Position (PT) control mode – differential line driver signal input .....	3-133
3.11.2	Position (PT) control mode – open-collector signal input .....	3-134
3.11.3	Position (PR) control mode – internal position commands .....	3-135
3.11.4	Speed (S) control mode .....	3-137
3.11.5	Torque (T) control mode .....	3-139
3.11.6	Communication mode (CANopen) .....	3-141
3.11.7	Communication mode (DMCNET) .....	3-142
3.11.8	Communication mode (EtherCAT) .....	3-143
3.12	400V series – Standard wiring example .....	3-144
3.12.1	Position (PT) control mode – differential line driver signal input .....	3-144
3.12.2	Position (PT) control mode – open-collector signal input .....	3-145
3.12.3	Position (PR) control mode – internal position commands .....	3-146
3.12.4	Speed (S) control mode .....	3-148
3.12.5	Torque (T) control mode .....	3-150
3.12.6	Communication mode (CANopen) .....	3-152
3.12.7	Communication mode (DMCNET) .....	3-153
3.12.8	Communication mode (EtherCAT) .....	3-154

# 4

## Test Operation and Panel Display

4.1	Panel description .....	4-2
4.2	Parameter setting procedure .....	4-3
4.3	Status display .....	4-6

4.3.1	Data save status .....	4-6
4.3.2	Decimal points.....	4-6
4.3.3	Alarm messages .....	4-7
4.3.4	Positive and negative sign setting .....	4-7
4.3.5	Monitoring display .....	4-7
4.4	General functions .....	4-11
4.4.1	Operation of fault record display .....	4-11
4.4.2	Force DO on .....	4-12
4.4.3	Digital input diagnosis operation .....	4-13
4.4.4	Digital output diagnosis operation .....	4-13
4.5	Testing.....	4-14
4.5.1	Testing without load .....	4-14
4.5.2	Apply power to A3 servo drive .....	4-15
4.5.3	JOG trial run without load.....	4-20
4.5.4	Trial run without load (Speed mode).....	4-22
4.5.5	Trial run without load (Position mode).....	4-24

## Tuning

# 5

## Tuning

5.1	Tuning procedure .....	5-4
5.2	Inertia (Weight) estimation.....	5-5
5.2.1	Precautions for inertia (weight) estimation .....	5-5
5.2.1.1	Rotary motor .....	5-5
5.2.1.2	Linear motor .....	5-6
5.2.2	Inertia (Weight) estimation with ASDA-Soft .....	5-7
5.2.2.1	Rotary motor .....	5-9
5.2.2.2	Linear motor .....	5-10
5.3	One Touch Tuning .....	5-11
5.3.1	Precautions for one touch tuning .....	5-12
5.3.1.1	Rotary motor .....	5-12
5.3.1.2	Linear motor .....	5-12
5.3.2	One touch tuning with ASDA-Soft .....	5-13
5.4	Auto tuning .....	5-16
5.4.1	Precautions for auto tuning.....	5-17
5.4.1.1	Rotary motor .....	5-17
5.4.1.2	Linear motor .....	5-18
5.4.2	Flowchart of auto tuning .....	5-19
5.4.3	Auto tuning through the drive panel .....	5-20

5.4.3.1	Rotary motor .....	5-20
5.4.3.2	Linear motor .....	5-21
5.4.4	Auto tuning with ASDA-Soft .....	5-22
5.4.5	Parameters related to auto tuning .....	5-29
5.4.5.1	Automatic gain adjustment level 1 (P2.105) - stiffness adjustment.....	5-29
5.4.5.2	Automatic gain adjustment level 2 (P2.106) - response adjustment .....	5-30
5.4.6	Alarms related to auto tuning .....	5-31
5.5	Gain adjustment modes.....	5-32
5.5.1	Differences between gain adjustment modes.....	5-32
5.5.2	Flowchart of gain adjustment mode .....	5-34
5.5.3	Gain adjustment mode 1 .....	5-35
5.5.4	Gain adjustment mode 2.....	5-35
5.5.5	Gain adjustment mode 3.....	5-36
5.5.6	Gain adjustment mode 4.....	5-37
5.5.7	Gain adjustment mode 5.....	5-38
5.5.8	Gain adjustment mode 6.....	5-38
5.5.9	Parameters related to gain adjustment modes.....	5-39
5.5.9.1	Bandwidth response level (P2.031) - stiffness adjustment .....	5-39
5.5.9.2	Command response gain (P2.089) - response adjustment .....	5-40
5.5.9.3	Bandwidth for speed loop response (P2.126) - bandwidth adjustment.....	5-40
5.6	Manual tuning of gain parameters .....	5-41
5.6.1	Flowchart of manual tuning in Speed mode.....	5-43
5.6.2	Flowchart of manual tuning in Position mode.....	5-44
5.6.3	Manual tuning with ASDA-Soft .....	5-45
5.7	Mechanical resonance suppression and noise elimination .....	5-46
5.7.1	Notch filter .....	5-47
5.7.1.1	Function restriction .....	5-47
5.7.1.2	Function description.....	5-47
5.7.1.3	Parameter descriptions.....	5-48
5.7.1.4	Application example.....	5-50
5.7.2	Resonance suppression low-pass filter .....	5-53
5.7.2.1	Function restriction .....	5-53
5.7.2.2	Function description.....	5-53
5.7.2.3	Application example.....	5-53
5.7.3	Speed detection filter .....	5-54
5.7.3.1	Function restriction .....	5-54
5.7.3.2	Function description.....	5-54
5.7.3.3	Application example.....	5-55
5.7.4	Low-frequency vibration suppression filter .....	5-56
5.7.4.1	Function restriction .....	5-56

5.7.4.2	Function description.....	5-56
5.7.4.3	Application example.....	5-58
5.7.5	Model-controlled vibration suppression filter.....	5-59
5.7.5.1	Restrictions of the two degree of freedom control function.....	5-59
5.7.5.2	Function description of two degree of freedom control function.....	5-60
5.7.5.3	Application example of two degree of freedom control function.....	5-61
5.7.5.4	Restrictions of vibration elimination .....	5-62
5.7.5.5	Function description of vibration elimination .....	5-62
5.7.5.6	Application example of vibration elimination .....	5-63
5.7.6	Position command filter .....	5-64
5.7.6.1	Function restriction .....	5-64
5.7.6.2	Function description.....	5-64
5.7.6.3	Application example.....	5-65
5.7.7	Speed command filter .....	5-66
5.7.7.1	Function restriction .....	5-66
5.7.7.2	Function description.....	5-66
5.7.7.3	Application example.....	5-66
5.7.8	Torque command filter.....	5-67
5.7.8.1	Function restriction .....	5-67
5.7.8.2	Function description.....	5-67
5.7.8.3	Application example.....	5-67
5.8	Application function adjustment .....	5-68
5.8.1	Adjusting position error in constant speed zone .....	5-68
5.8.1.1	Function restriction .....	5-68
5.8.1.2	Function description.....	5-68
5.8.1.3	Application example.....	5-69
5.8.2	Position overshoot adjustment .....	5-70
5.8.2.1	Function restriction .....	5-70
5.8.2.2	Function description.....	5-70
5.8.2.3	Application example.....	5-70
5.8.3	Multi-axis contour control .....	5-71
5.8.3.1	Function restriction .....	5-71
5.8.3.2	Function description.....	5-71
5.8.3.3	Application example.....	5-73
5.8.4	Gain switching.....	5-75
5.8.4.1	Function restriction .....	5-75
5.8.4.2	Function description.....	5-75
5.8.4.3	Application example.....	5-75

# Operation and Motion Control

## 6

### Operation Mode

6.1	Selecting the operation mode.....	6-3
6.2	Position mode .....	6-5
6.2.1	Position command in PT mode.....	6-5
6.2.2	Position command in PR mode .....	6-6
6.2.3	Control structure of Position mode .....	6-7
6.2.4	S-curve filter (Position) .....	6-8
6.2.5	Electronic gear ratio (E-Gear ratio).....	6-10
6.2.6	Low-pass filter .....	6-11
6.2.7	Timing diagram of PR mode .....	6-11
6.2.8	Gain adjustment of the position loop.....	6-12
6.2.9	Low-frequency vibration suppression in Position mode .....	6-14
6.3	Speed mode .....	6-17
6.3.1	Selecting the Speed command source .....	6-17
6.3.2	Control structure of Speed mode .....	6-18
6.3.3	Smooth Speed command.....	6-19
6.3.4	Scaling of the analog command.....	6-21
6.3.5	Timing diagram of Speed mode.....	6-22
6.3.6	Gain adjustment of the speed loop.....	6-23
6.3.7	Resonance suppression unit.....	6-25
6.4	Torque mode .....	6-28
6.4.1	Selecting the Torque command source .....	6-28
6.4.2	Control structure of Torque mode.....	6-29
6.4.3	Smooth Torque command .....	6-29
6.4.4	Scaling of the analog command.....	6-30
6.4.5	Timing diagram of Torque mode .....	6-31
6.5	Dual mode / Multi-mode.....	6-32
6.5.1	Speed / Position dual mode.....	6-33
6.5.2	Speed / Torque dual mode .....	6-34
6.5.3	Torque / Position dual mode .....	6-35
6.6	Others .....	6-36
6.6.1	Applying the speed limit.....	6-36
6.6.2	Applying the torque limit .....	6-36
6.6.3	Analog monitoring .....	6-37
6.7	Full-closed loop control system .....	6-38
6.7.1	Hardware configuration .....	6-39
6.7.2	Control structure .....	6-41

6.7.3	Steps for setting the full-closed loop function.....	6-43
6.7.4	Parameters for full-closed loop function.....	6-44
6.7.4.1	Auxiliary encoder direction setting.....	6-44
6.7.4.2	Auxiliary encoder resolution setting .....	6-47
6.7.4.3	E-Gear settings .....	6-50
6.7.4.4	Setting the protection range for the feedback position error between the main encoder and auxiliary encoder .....	6-50
6.7.4.5	Setting the low-pass filter time constant for full- / semi-closed loop control .....	6-51
6.7.4.6	Setting the error clearing function when switching between full- and semi-closed loops .....	6-52
6.7.4.7	Auto clearing of the feedback position error between the main encoder and auxiliary encoder .....	6-55
6.7.4.8	Set DI [0x0B] to switch between full- and semi-closed loop modes.....	6-56
6.7.4.9	Z phase source of homing.....	6-57
6.7.4.10	Encoder output settings .....	6-58
6.7.4.11	Full-closed loop feedback source for the controller.....	6-60
6.7.5	Troubleshooting full-closed loop alarms.....	6-61

# 7

## Motion Control

7.1	PR mode description.....	7-3
7.1.1	Shared PR parameters.....	7-5
7.1.2	Monitoring variables of PR mode .....	7-7
7.1.3	Motion Control commands .....	7-10
7.1.3.1	Homing methods.....	7-10
7.1.3.2	Speed command.....	7-23
7.1.3.3	Position command.....	7-25
7.1.3.4	Jump command .....	7-28
7.1.3.5	Write command .....	7-30
7.1.3.6	Rotary Axis Position command (Index).....	7-32
7.1.3.7	Arithmetic operation (Statement) .....	7-36
7.1.4	Overview of the PR procedure .....	7-39
7.1.5	Trigger methods for the PR command.....	7-46
7.1.6	PR procedure execution flow .....	7-50
7.2	Application of motion control .....	7-64
7.2.1	Data array .....	7-64
7.2.2	High-speed position capture function (Capture).....	7-68
7.2.3	High-speed position compare function (Compare) .....	7-72
7.3	E-Cam.....	7-76
7.3.1	Source signal for the master axis .....	7-77
7.3.2	Clutch engagement and disengagement .....	7-81



7.3.3	E-Cam gears and curve scaling.....	7-89
7.3.4	E-Cam curve.....	7-92
7.3.5	E-Cam curve and PR command overlapping.....	7-100
7.3.6	Troubleshooting for E-Cam.....	7-102
7.3.7	Rotary Shear.....	7-104
7.3.8	Flying Shear.....	7-131
7.3.9	Macro.....	7-144
7.3.10	Auxiliary function.....	7-154
7.3.11	Horizontal packing machine applications.....	7-157

## Parameter Setting

# 8

## Parameters

8.1	Parameter definitions.....	8-2
8.2	List of parameters.....	8-3
8.3	Parameter descriptions.....	8-25
	P0.xxx Monitoring parameters.....	8-25
	P1.xxx Basic parameters.....	8-42
	P2.xxx Extension parameters.....	8-93
	P3.xxx Communication parameters.....	8-141
	P4.xxx Diagnosis parameters.....	8-151
	P5.xxx Motion control parameters.....	8-161
	P6.xxx PR parameters.....	8-204
	P7.xxx PR parameters.....	8-228
	PM.xxx Motor parameters.....	8-248
	Table 8.1 Digital input (DI) descriptions.....	8-267
	Table 8.2 Digital output (DO) descriptions.....	8-275
	Table 8.3 Monitoring variables descriptions.....	8-282

# 9

## Modbus Communication

9.1	RS-485 communication interface (hardware).....	9-2
9.2	RS-485 communication parameter settings.....	9-3
9.3	Modbus communication protocol.....	9-4
9.4	Setting and accessing communication parameters.....	9-15
9.5	RS-485 communication specification.....	9-16

# 10

## Absolute System

10.1	Battery box and absolute encoder cable .....	10-3
10.1.1	Battery specifications .....	10-3
10.1.2	Battery box dimensions.....	10-5
10.1.3	Connection cable for the absolute encoder.....	10-6
10.1.4	Battery box cable.....	10-7
10.2	Installation .....	10-8
10.2.1	Installing the battery box in the servo system.....	10-8
10.2.2	Installing and replacing batteries.....	10-11
10.3	System initialization and operating procedures.....	10-14
10.3.1	System initialization .....	10-14
10.3.2	Pulse number .....	10-15
10.3.3	PUU number .....	10-16
10.3.4	Establishing the absolute origin position .....	10-17
10.3.4.1	Establishing the absolute origin position with DI/DO .....	10-17
10.3.4.2	Establishing the absolute origin position with parameters .....	10-18
10.3.4.3	Establishing the absolute origin position with the PR homing function .....	10-18
10.3.5	Reading the absolute position .....	10-18
10.3.5.1	Reading the absolute position with DI/DO .....	10-18
10.3.5.2	Reading the absolute position with communication .....	10-21
10.4	Parameters, DI/DO, and alarms related to absolute function .....	10-23

# 11

## Linear Motor and Third-Party Motor

11.1	Linear motor overview.....	11-3
11.2	Installation and configuration .....	11-4
11.2.1	Precautions for installing linear motors .....	11-4
11.2.2	Configurations for linear motors and rotary motors .....	11-7
11.2.2.1	Peripheral configuration for pulse type motors.....	11-8
11.2.2.2	Peripheral configuration for pulse type and sine wave type motors .....	11-9
11.2.2.3	Peripheral configuration for Delta motors and third-party communication type motors .....	11-10
11.2.3	Communication type motors .....	11-11
11.2.3.1	Third-party communication type motors .....	11-11
11.2.3.2	Supported communication format for the motors.....	11-12
11.2.3.3	Pin assignment of communication type motors.....	11-12
11.3	Complete the settings for linear motors and third-party motors with ASDA-Soft.....	11-13
11.3.1	Motor parameter identification .....	11-14
11.3.1.1	Motor parameter identification for linear motors .....	11-15
11.3.1.2	Motor parameter identification for rotary motors.....	11-22

11.3.2	Linear motor direction setting .....	11-29
11.4	Linear encoder .....	11-30
11.5	Hall sensor .....	11-31
11.5.1	Installing the Hall sensor .....	11-32
11.5.2	Checking the Hall sensor phase sequence .....	11-33
11.6	Position signal converter box .....	11-34
11.6.1	Specifications of position signal converter box .....	11-34
11.6.2	Interface of position signal converter box .....	11-35
11.6.3	Pin assignment of position signal converter box .....	11-36
11.7	Linear motor parameter setting .....	11-37
11.7.1	Total weight (mover + load) .....	11-37
11.7.2	E-Gear ratio .....	11-37
11.7.3	Limit setting .....	11-37
11.7.4	Current setting for initial magnetic field detection .....	11-38
11.7.5	Overload gain .....	11-39

# 12

## CANopen Mode

12.1	Basic configuration .....	12-2
12.1.1	Supported functions .....	12-2
12.1.2	Hardware configuration .....	12-3
12.1.3	Parameter settings in CANopen mode .....	12-4
12.2	Communication specification .....	12-5
12.2.1	Servo communication architecture .....	12-5
12.2.2	Communication objects .....	12-6
12.2.2.1	Process data object (PDO) .....	12-7
12.2.2.2	Service data object (SDO) .....	12-8
12.2.2.3	SDO abort codes .....	12-11
12.2.2.4	Synchronization object (SYNC) .....	12-12
12.2.2.5	Emergency object (EMCY) .....	12-13
12.2.2.6	NMT services .....	12-14
12.3	CANopen operation modes .....	12-17
12.3.1	Profile Position mode .....	12-17
12.3.2	Interpolated Position mode .....	12-22
12.3.3	Homing mode .....	12-25
12.3.4	Profile Velocity mode .....	12-27
12.3.5	Profile Torque mode .....	12-29
12.4	Object dictionary .....	12-31
12.4.1	Specifications for objects .....	12-31
12.4.2	List of objects .....	12-32
12.4.3	Details of objects .....	12-34

12.4.3.1	OD 1XXXh communication object group .....	12-34
12.4.3.2	OD 2XXXh servo parameter group .....	12-53
12.4.3.3	OD 6XXXh communication object group .....	12-54
12.5	Diagnostics and troubleshooting .....	12-96

# 13

## EtherCAT Mode

13.1	Basic configuration .....	13-3
13.1.1	Hardware configuration .....	13-3
13.1.2	ESI file import .....	13-7
13.1.3	Parameter settings of EtherCAT mode .....	13-8
13.2	Communication function .....	13-12
13.2.1	Specifications .....	13-12
13.2.2	Synchronization mode .....	13-14
13.2.2.1	Synchronization modes of the servo drive .....	13-14
13.2.2.2	Select Synchronization mode .....	13-15
13.2.2.3	Distributed clocks setting .....	13-15
13.2.3	EtherCAT state machine .....	13-16
13.2.4	PDO mapping configuration .....	13-18
13.2.4.1	Default PDO mapping configuration .....	13-18
13.2.4.2	Set PDO mapping .....	13-20
13.2.4.3	PDO mapping object .....	13-21
13.2.4.4	SDO abort codes .....	13-22
13.3	EtherCAT operation modes .....	13-23
13.3.1	Profile Position mode .....	13-23
13.3.2	Profile Velocity mode .....	13-28
13.3.3	Profile Torque mode .....	13-30
13.3.4	Homing mode .....	13-32
13.3.5	Cyclic Synchronous Position mode .....	13-34
13.3.6	Cyclic Synchronous Velocity mode .....	13-36
13.3.7	Cyclic Synchronous Torque mode .....	13-38
13.3.8	Touch Probe function and Touch Probe status .....	13-40
13.4	Object dictionary .....	13-45
13.4.1	Specifications for objects .....	13-45
13.4.2	List of objects .....	13-46
13.4.3	Details of objects .....	13-48
13.4.3.1	OD 1XXXh communication object group .....	13-48
13.4.3.2	OD 2XXXh servo parameter group .....	13-54
13.4.3.3	OD 6XXXh communication object group .....	13-55
13.5	Diagnostics and troubleshooting .....	13-96
13.5.1	EtherCAT Diagnosis .....	13-96

13.5.2 Alarm list .....	13-97
-------------------------	-------

## Troubleshooting

# 14 Troubleshooting

14.1 Alarm list .....	14-3
General type .....	14-3
STO type .....	14-5
Communication type .....	14-6
Motion control type .....	14-7
Third-party communication type .....	14-9
14.2 Causes and corrective actions .....	14-10

## Appendix

# A Specifications

A.1 ASDA-A3 series servo drive .....	A-3
A.1.1 Specifications of the servo drive .....	A-3
A.1.1.1 220V series .....	A-3
A.1.1.2 400V series .....	A-6
A.1.2 Dimensions of the servo drive .....	A-9
A.1.2.1 220V series .....	A-9
A.1.2.2 400V series .....	A-13
A.2 ECM-A3 series servo motor .....	A-15
A.2.1 Specifications of ECM-A3L low inertia series servo motor .....	A-17
A.2.2 Specifications of ECM-A3H high inertia series servo motor .....	A-19
A.2.3 Torque features (T-N curves) of the A3 motors .....	A-21
A.2.4 Overload features .....	A-23
A.2.5 Dimensions of ECM-A3L/A3H series servo motor .....	A-24
A.3 ECM-B3 series servo motor .....	A-25
A.3.1 Specifications of ECM-B3 series servo motor .....	A-27
A.3.1.1 220V series .....	A-27
Motor frame size: 80 mm and below (low & medium inertia) .....	A-27
Motor frame size: 80 mm and below (high inertia) .....	A-29
Motor frame size: 100 mm (medium inertia) .....	A-31
Motor frame size: 130 mm (medium & high inertia) .....	A-33
Motor frame size: 180 mm (medium inertia) .....	A-35
Motor frame size: 220 mm (medium inertia) .....	A-37
A.3.1.2 400V series .....	A-39

Motor frame size: 80 mm and below (medium inertia) .....	A-39
Motor frame size: 100 mm (medium inertia) .....	A-41
Motor frame size: 130 mm (medium & high inertia) .....	A-43
Motor frame size: 180 mm (medium inertia) .....	A-45
Motor frame size: 220 mm (medium inertia) .....	A-47
A.3.2 Torque features (T-N curves) of the B3 motors .....	A-49
A.3.2.1 220V series .....	A-49
Motor frame size: 80 mm and below .....	A-49
Motor frame size: 100 mm .....	A-50
Motor frame size: 130 mm .....	A-51
Motor frame size: 180 mm .....	A-52
Motor frame size: 220 mm .....	A-53
A.3.2.2 400V series .....	A-54
Motor frame size: 80 mm and below .....	A-54
Motor frame size: 100 mm .....	A-54
Motor frame size: 130 mm .....	A-55
Motor frame size: 180 mm .....	A-56
Motor frame size: 220 mm .....	A-57
A.3.3 Power derating curves of the B3 motors .....	A-58
A.3.4 Overload features .....	A-59
A.3.5 Dimensions of ECM-B3 series servo motor .....	A-61
A.3.5.1 220V series .....	A-61
Motor frame size: 80 mm and below, with cables (low & medium & high inertia) .....	A-61
Motor frame size: 80 mm and below, with bulkhead connectors (low & medium & high inertia) .....	A-62
Motor frame size: 100 mm (medium inertia) .....	A-63
Motor frame size: 130 mm (medium & high inertia) .....	A-64
Motor frame size: 180 mm (medium inertia) .....	A-65
Motor frame size: 220 mm (medium inertia) .....	A-66
A.3.5.2 400V series .....	A-67
Motor frame size: 80 mm and below, with cables (medium inertia) .....	A-67
Motor frame size: 100 mm (medium inertia) .....	A-68
Motor frame size: 130 mm (medium & high inertia) .....	A-69
Motor frame size: 180 mm (medium inertia) .....	A-70
Motor frame size: 220 mm (medium inertia) .....	A-71



# B

## Accessories

B.1	Power connector.....	B-3
B.1.1	F40 - F80 motors .....	B-3
B.1.2	F100 - F130 motors.....	B-5
B.1.3	F180 4.5 kW (or below) motors .....	B-6
B.1.4	F180 5.5 kW (or above) and F220 motors .....	B-7
B.1.5	Brake connector for F100 - F220 motors .....	B-8
B.2	Power cable.....	B-9
B.2.1	F40 - F80 motors .....	B-9
B.2.2	F100 - F130 motors.....	B-14
B.2.3	F180 4.5 kW (or below) motors .....	B-16
B.2.4	F180 5.5 kW (or above) and F220 motors .....	B-18
B.2.5	Brake cable for F100 - F220 motors .....	B-20
B.3	Encoder connector.....	B-22
B.3.1	F40 - F80 motors .....	B-22
B.3.2	F100 - F220 motors.....	B-23
B.4	Encoder cable (incremental type) .....	B-24
B.4.1	F40 - F80 motors .....	B-24
B.4.2	F100 - F220 motors.....	B-26
B.5	Encoder cable (absolute type) .....	B-28
B.5.1	F40 - F80 motors .....	B-28
B.5.2	F100 - F220 motors .....	B-30
B.6	Battery box cable .....	B-32
B.7	Battery box .....	B-33
B.8	CN1 connector .....	B-34
B.9	CN1 quick connector .....	B-35
B.10	CN1 terminal block module.....	B-36
B.11	CANopen communication cable.....	B-38
B.12	CANopen distribution box.....	B-38
B.13	Ferrite ring.....	B-39
B.14	A3 / A2 conversion cable .....	B-39
B.15	CN3 RS-485 splitter .....	B-40
B.16	CN3 RS-485 / CANopen terminal resistor .....	B-40
B.17	CN4 Mini USB communication module.....	B-41
B.18	Position signal converter box .....	B-42
B.19	Optional accessories.....	B-43
220V models .....	B-43	
F40 - F80 motors .....	B-43	
F100 - F130 motors .....	B-44	
F180 4.5 kW (or below) motors .....	B-45	

F180 5.5 kW (or above) and F220 motors.....	B-46
400V models .....	B-47
F40 - F80 motors .....	B-47
F100 - F130 motors .....	B-48
F180 4.5 kW (or below) motors .....	B-49
F180 5.5 kW (or above) and F220 motors.....	B-50

(This page is intentionally left blank.)

# Product Overview

# 1

Before using the ASDA-A3 series servo drive, pay attention to the description of the inspection, nameplate, and model type. You can find a suitable motor model for your A3 servo drive in the table in Section 1.3.

---

1.1	Items to check after unpacking .....	1-2
1.2	Model overview .....	1-3
1.2.1	Nameplate information .....	1-3
1.2.2	Model explanation .....	1-5
1.3	ASDA-A3 servo drive and motor .....	1-11
1.3.1	220V models .....	1-11
1.3.2	400V models .....	1-14
1.4	Description of the drive interface .....	1-15
1.4.1	220V models: A3-L .....	1-15
1.4.2	220V models: A3-M .....	1-16
1.4.3	220V models: A3-F .....	1-17
1.4.4	220V models: A3-E .....	1-18
1.4.5	400V models: A3-L .....	1-19
1.4.6	400V models: A3-M .....	1-20
1.4.7	400V models: A3-F .....	1-21
1.4.8	400V models: A3-E .....	1-22

## 1.1 Items to check after unpacking

A complete servo drive set includes:

- (1) A servo drive.
- (2) An STO connector for CN10 (220V A3-M, A3-E models, and all 400V models).
- (3) Pluggable terminal blocks (varies based on the models) and one plastic lever.

### 220V Models

100 W - 1.5 kW	R, S, T	3-pin pluggable terminal block
	L <sub>1c</sub> , L <sub>2c</sub> , P1, P2, $\ominus$	5-pin pluggable terminal block
	P3, D, C	3-pin pluggable terminal block
	U, V, W	3-pin pluggable terminal block

### 400V Models

400 W - 1.5 kW	R, S, T	3-pin pluggable terminal block
	24V, 0V	2-pin pluggable terminal block
	P1, P2, $\ominus$ , P3, D, C	6-pin pluggable terminal block
	U, V, W	3-pin pluggable terminal block

- (4) Two metal pieces for short-circuiting the terminal block: for 220V 100 W - 4.5 kW models and 400V 400 W - 1.5 kW models.  
One metal piece for short-circuiting the terminal block: for 220V 5.5 kW - 15 kW models and 400V 2 kW - 15 kW models.
- (5) An installation instruction sheet.

## 1.2 Model overview

### 1.2.1 Nameplate information

#### ASDA-A3 series servo drive

##### ■ Nameplate information

Model number --- MODEL: ASD-A3-0421-L  
 Applicable power supply --- INPUT: 200-230V 3PH 50/60Hz 2.67A  
 200-230V 1PH 50/60Hz 4.63A  
 Rated power output --- OUTPUT: 110V 0-500Hz 2.6A  
 Capacity specification --- POWER: 400W

Serial number and QR code --- A30421L0T15070006  
 Firmware version --- 0.41

DELTA ELECTRONICS, INC  
 No.18, Xinglong Rd., Taoyuan City 330477

**WARNING** DISCONNECT ALL POWER AND WAIT 10 MINUTES BEFORE SERVICING RISK OF ELECTRIC SHOCK.  
**CAUTION** DO NOT TOUCH HEATSINK WHEN POWER IS ON. MAY CAUSE BURN.  
**CAUTION** READ THE USER MANUAL BEFORE OPERATION.  
 USE PROPER GROUNDING TECHNIQUES

UL CERTIFIED SAFETY US CA E176972 IND.CONT.EQ.  
 UK CA  
 CE ENEC 20  
 R-R-DVP ASD-XXXXXXXXXX  
 TÜV SUD  
 SERVICE.DELTAWW.COM

Model number --- MODEL: ASD-A3-0743-E  
 Applicable power supply --- INPUT: 380-480V 3PH 50/60Hz 1.8A  
 Rated power output --- OUTPUT: 220V 0-500Hz 3.12A  
 Capacity specification --- POWER: 750W

Serial number and QR code --- A30743E0W22280006  
 Firmware version --- 0.41

DELTA ELECTRONICS, INC  
 No.18, Xinglong Rd., Taoyuan City 330477

**WARNING** DISCONNECT ALL POWER AND WAIT 10 MINUTES BEFORE SERVICING RISK OF ELECTRIC SHOCK.  
**CAUTION** DO NOT TOUCH HEATSINK WHEN POWER IS ON. MAY CAUSE BURN.  
**CAUTION** READ THE USER MANUAL BEFORE OPERATION.  
 USE PROPER GROUNDING TECHNIQUES

UL CERTIFIED SAFETY US CA E176972 IND.CONT.EQ.  
 UK CA  
 CE ENEC 20  
 R-R-DVP ASD-XXXXXXXXXX  
 TÜV SUD  
 SERVICE.DELTAWW.COM

Note: TÜV certification for 220V models is in progress.

##### ■ Serial number

A30743E0 W 22 28 0006  
 (1) (2) (3) (4) (5)

- (1) Model number
- (2) Manufacturing plant (T: Taoyuan; W: Wujiang)
- (3) Year of production (22: year 2022)
- (4) Week of production (from 1 to 52)
- (5) Production sequence in a week (starting from 0001)



**ECM-A3 / ECM-B3 series servo motor**

■ **Nameplate information**



Model number -----

Applicable power supply -----

Rated output -----

QR code and serial number -----



<ul style="list-style-type: none"> <li>● MODEL: ECM-A3H-CY0602RS0</li> <li>● INPUT: VAC110 A1.45 Ins.A</li> <li>● OUTPUT: r/min 3000 N.m 0.64 kW 0.2</li> </ul>	
	No.18, Xinglong Rd., Taoyuan City 30477 ABCYB1JAT16070001

■ **Serial number**

ABCYB1JA	W	16	07	0001	
(1)	(2)	(3)	(4)	(5)	

(1) Model number  
 (2) Manufacturing plant (T: Taoyuan; W: Wujiang)  
 (3) Year of production (16: year 2016)  
 (4) Week of production (from 1 to 52)  
 (5) Production sequence in a week (starting from 0001)

Note: the rated voltage written in the servo motor specifications indicates the input voltage for the servo drive. The servo motor uses the certified voltage as the rated input voltage for operation, so the applicable power supply for 220V series servo motor is 110V, and the applicable power supply for 400V series servo motor is 220V.

**ECMC series servo motor**

■ **Nameplate information**



Model number -----

Applicable power supply -----

Rated output -----

QR code and serial number -----



<ul style="list-style-type: none"> <li>● MODEL: ECMC-CW1010RS</li> <li>● INPUT: VAC 110 A 7.3 Ins A</li> <li>● OUTPUT: r/min 3000 N.m 3.18 kW 1.0</li> </ul>	
	CW1010RSW16070001 Delta Electronics, Inc.

■ **Serial number**

CW1010RS	W	16	07	0001	
(1)	(2)	(3)	(4)	(5)	

(1) Model number  
 (2) Manufacturing plant (T: Taoyuan; W: Wujiang)  
 (3) Year of production (16: year 2016)  
 (4) Week of production (from 1 to 52)  
 (5) Production sequence in a week (starting from 0001)

Note: the servo motor uses the certified voltage as the rated input voltage for operation, so the applicable power supply is 110V.

## 1.2.2 Model explanation

### ASDA-A3 series servo drive

ASD – A3 – 04 21 – L  
(1) (2) (3) (4) (5)

(1) Product name  
ASD: AC Servo Drive

(2) Series  
A3: A3 Series

(3) Rated power output

Code	Specification	Code	Specification	Code	Specification
01	100 W	15	1.5 kW	75	7.5 kW
02	200 W	20	2.0 kW	1B	11 kW
04	400 W	30	3.0 kW	1F	15 kW
07	750 W	45	4.5 kW	-	-
10	1.0 kW	55	5.5 kW	-	-

(4) Input voltage and phase  
21: 220V, single- / three-phase  
23: 220V, three-phase  
43: 400V, three-phase

(5) Model type

#### 220V models

Code	Pulse input	RS-485	CANopen	Full-closed loop control	Analog voltage control	DMCNET	E-CAM	STO	EtherCAT
L	✓	✓	-	✓	✓	-	-	-	-
M	✓	✓	✓	✓*	✓	-	✓	✓	-
F	-	-	-	✓*	-	✓	✓	-	-
E	-	-	-	✓*	-	-	✓	✓	✓

#### 400V models

Code	Pulse input	RS-485	CANopen	Full-closed loop control	Analog voltage control	DMCNET	E-CAM	STO	EtherCAT
L	✓	✓	-	✓	✓	-	-	✓	-
M	✓	✓	✓	✓*	✓	-	✓	✓	-
F	-	-	-	✓*	-	✓	✓	✓	-
E	-	-	-	✓*	-	-	✓	✓	✓

Note:

- Columns with an \* means that this function is coming soon.
- The model codes listed here are only for demonstration of the naming convention, some combinations of the model codes are not available. Contact the distributors for the model names available for purchase.

**ECM-A3 series servo motor**

ECM - A 3 H - C Y 06 04 R S 1  
 (1) (2) (3) (4) (5) (6) (7) (8) (9) (10) (11)

1

- (1) Product name  
ECM: electronically commutated motor
- (2) Servo type  
A: high-precision servo motor
- (3) Series  
3: A3 series
- (4) Inertia  
H: high inertia  
L: low inertia
- (5) Rated voltage and speed  
C: 220V and 3,000 rpm
- (6) Encoder type  
Y: 24-bit absolute optical encoder  
(resolution of single turn: 24-bit; number of revolutions: 16-bit)  
1: 24-bit incremental optical encoder (single-turn absolute)  
A: 24-bit absolute optical encoder  
(resolution of single turn: 24-bit; number of revolutions: 16-bit)  
2: 24-bit incremental optical encoder (single-turn absolute)  
Note: number of revolutions means the maximum number of turns the encoder can record
- (7) Motor frame size  
04: 40 mm  
06: 60 mm  
08: 80 mm

(8) Rated power output

Code	Specification	Code	Specification
0F	50 W	04	400 W
01	100 W	07	750 W
02	200 W	-	-

## (9) Shaft type and oil seal

	w/o brake w/o oil seal	with brake w/o oil seal	w/o brake with oil seal	with brake with oil seal
Round shaft (with fixed screw holes)	-	-	C	D
Keyway (with fixed screw holes)	P*	Q*	R	S

Note: \* indicates this model type is coming soon.

## (10) Shaft diameter and connector type

S: standard shaft diameter and standard connectors

7: special shaft diameter (14 mm)\* and standard connectors

J: standard shaft diameter and CHOGORI (IP67) connectors

K: special shaft diameter (14 mm)\* and CHOGORI (IP67) connectors

Note: special shaft diameter is available for F80 400W models.

## (11) Special code

1: standard products

Z: special code of C<sup>2</sup>0807<sup>3</sup>S<sup>5</sup>. Refer to the note in Section A.2.5.

Note: the model codes listed here are only for demonstration of the naming convention, some combinations of the model codes are not available. Contact the distributors for the model names available for purchase.

**ECM-B3 series servo motor**

$$\frac{\text{ECM}}{(1)} - \frac{\text{B}}{(2)} \frac{\text{3}}{(3)} \frac{\text{M}}{(4)} - \frac{\text{C}}{(5)} \frac{\text{2}}{(6)} \frac{\text{06}}{(7)} \frac{\text{04}}{(8)} \frac{\text{R}}{(9)} \frac{\text{S}}{(10)} \frac{\text{1}}{(11)}$$

1

(1) Product name  
ECM: electronically commutated motor

(2) Servo type  
B: general type servo motor

(3) Series  
3: 3<sup>rd</sup> series

(4) Inertia  
H: high inertia  
M: medium inertia  
L: low inertia

(5) Rated voltage and speed  
C: 220V and 3,000 rpm  
E: 220V and 2,000 rpm  
F: 220V and 1,500 rpm  
J: 400V and 3,000 rpm  
K: 400V and 2,000 rpm  
L: 400V and 1,500 rpm

(6) Encoder type  
A: 24-bit absolute optical encoder  
(resolution of single turn: 24-bit; number of revolutions: 16-bit)  
2: 24-bit incremental optical encoder (single-turn absolute)  
P: 17-bit absolute magnetic encoder  
(resolution of single turn: 17-bit; number of revolutions: 16-bit)  
M: 17-bit incremental magnetic encoder (single-turn absolute)  
Note: number of revolutions means the maximum number of turns the encoder can record.

(7) Motor frame size

Code	Specification	Code	Specification
04	40 mm	13	130 mm
06	60 mm	18	180 mm
08	80 mm	22	220 mm
10	100 mm	-	-

## (8) Rated power output

Code	Specification	Code	Specification
01	100 W	18	1.8 kW
02	200 W	20	2.0 kW
04	400 W	30	3.0 kW
07	750 W	45	4.5 kW
08	850 W	55	5.5 kW
10	1.0 kW	75	7.5 kW
13	1.3 kW	1B	11 kW
15	1.5 kW	1F	15 kW

## (9) Shaft type and oil seal

	w/o brake, with oil seal	with brake, with oil seal
Keyway (with fixed screw holes)	R	S

## (10) Shaft diameter and connector type

S: standard shaft diameter and standard connectors

7: special shaft diameter (14 mm)<sup>\*1</sup> and standard connectors

J: standard shaft diameter and CHOGORI (IP67) connectors

K: special shaft diameter (14 mm)<sup>\*1</sup> and CHOGORI (IP67) connectors

3: standard shaft diameter (42 mm)<sup>\*2</sup> and standard connectors

B: standard shaft diameter and bulkhead connectors

Note:

1. Special shaft diameter (14 mm) is only available for F80 400 W models.

2. Standard shaft diameter (42 mm) is only available for F180 5.5 kW and 7.5 kW models and F220 11 kW models.

## (11) Special code

1: standard products

Note: the model codes listed here are only for demonstration of the naming convention, some combinations of the model codes are not available. Contact the distributors for the model names available for purchase.

1

**ECMC series servo motor**

ECM C - F W 13 08 R S  
 (1) (2) (3) (4) (5) (6) (7) (8)

1

- (1) Product name  
ECM: electronically commutated motor
- (2) Servo type  
C: high-precision AC servo motor (recommended for CNC applications)
- (3) Rated voltage and speed  
C: 220V and 3,000 rpm  
E: 220V and 2,000 rpm  
F: 220V and 1,500 rpm
- (4) Encoder type  
W: 22-bit absolute encoder  
(resolution of single turn: 22-bit; number of revolutions: 16-bit).
- (5) Motor frame size  
10: 100 mm  
13: 130 mm  
18: 180 mm

- (6) Rated power output

Code	Specification	Code	Specification
08	850 W	18	1.8 kW
10	1.0 kW	20	2.0 kW
13	1.3 kW	30	3.0 kW
15	1.5 kW	-	-

- (7) Shaft type and oil seal

	w/o brake w/o oil seal	with brake w/o oil seal	w/o brake with oil seal	with brake with oil seal
Round shaft (with fixed screw holes)	-	-	C	D
Keyway (with fixed screw holes)	-	-	R	S

- (8) Shaft diameter  
S: standard

Note: the model codes listed here are only for demonstration of the naming convention, some combinations of the model codes are not available. Contact the distributors for the model names available for purchase.

## 1.3 ASDA-A3 servo drive and motor

### 1.3.1 220V models

#### ECM-A3 series servo motor

Servo motor model							Servo drive model
Inertia	Rated / Max. speed	Power	Output (W)	Model name	Rated torque (N·m)	Max. torque (N·m)	Model name
Low inertia	3000 / 6000 rpm	Single- / three-phase	50	ECM-A3L-C2040F341	0.159	0.557	ASD-A3-0121-1
			100	ECM-A3L-C20401341	0.32	1.12	
			200	ECM-A3L-C20602341	0.64	2.24	ASD-A3-0221-1
			400	ECM-A3L-C20604341	1.27	4.45	ASD-A3-0421-1
			400	ECM-A3L-C20804341	1.27	4.44	
			750	ECM-A3L-C20807345	2.39	8.36	ASD-A3-0721-1
High inertia		Single- / three-phase	50	ECM-A3H-C2040F341	0.159	0.557	ASD-A3-0121-1
			100	ECM-A3H-C20401341	0.32	1.12	
			200	ECM-A3H-C20602341	0.64	2.24	ASD-A3-0221-1
			400	ECM-A3H-C20604341	1.27	4.45	ASD-A3-0421-1
			400	ECM-A3H-C20804341	1.27	4.44	
			750	ECM-A3H-C20807345	2.39	8.36	ASD-A3-0721-1

1



ECM-B3 series servo motor

Servo motor model							Servo drive model
Inertia	Rated / Max. speed	Power	Output (W)	Model name	Rated torque (N·m)	Max. torque (N·m)	Model name
Low inertia	3000 / 6000 rpm	Single- / three-phase	100	ECM-B3L-C20401341	0.32	1.12	ASD-A3-0121-1
			200	ECM-B3M-C20602341	0.64	2.24	ASD-A3-0221-1
400			ECM-B3M-C20604341	1.27	4.45	ASD-A3-0421-1	
400			ECM-B3M-C20804341	1.27	4.45		
750			ECM-B3M-C20807341	2.4	8.4	ASD-A3-0721-1	
1000			ECM-B3M-C20810341	3.18	11.13	ASD-A3-1021-1	
1000			ECM-B3M-C21010341	3.18	9.54	ASD-A3-1021-1	
1500			ECM-B3M-C21015341	4.77	14.3	ASD-A3-1521-1	
2000			ECM-B3M-C21020341	6.37	19.1	ASD-A3-2023-1	
2000 / 3000 rpm			Three-phase	1000	ECM-B3M-E21310341	4.47	14.3
	1500	ECM-B3M-E21315341		7.16	21.48	ASD-A3-1521-1	
	2000	ECM-B3M-E21320341		9.55	28.65	ASD-A3-2023-1	
High inertia	1500 / 4000 rpm	Single- / three-phase	850	ECM-B3H-F21308341	5.39	16.17	ASD-A3-1021-1
			1300	ECM-B3H-F21313341	8.34	25.02	ASD-A3-1521-1
		Three-phase	1800	ECM-B3H-F21318341	11.5	34.5	ASD-A3-2023-1
Medium inertia	2000 / 3000 rpm	Three-phase	2000	ECM-B3M-E21820341	9.55	28.65	ASD-A3-2023-1
	1500 / 3000 rpm		3000	ECM-B3M-F21830341	19.1	57.29	ASD-A3-3023-1
	1500 / 4500 rpm		4500	ECM-B3M-F21845341	28.65	71.6	ASD-A3-4523-1
			5500	ECM-B3M-F21855341	35.01	105	ASD-A3-5523-1
			7500	ECM-B3M-F21875341	47.75	119	ASD-A3-7523-1
			11000	ECM-B3M-F2221B341	70.03	175	ASD-A3-1B23-1
			15000	ECM-B3M-F2221F341	95.49	238.5	ASD-A3-1F23-1

1

## ECMC series servo motor

Servo motor model							Servo drive model	
Inertia	Rated / Max. speed	Power	Output (W)	Model name	Rated torque (N·m)	Max. torque (N·m)	Model name	
Medium inertia	3000 / 5000 rpm	Single- / three-phase	1000	ECMC-C <sup>②</sup> 1010 <sup>③④</sup>	3.18	9.54	ASD-A3-1021- <sup>①</sup>	
			1000	ECMC-E <sup>②</sup> 1310 <sup>③④</sup>	4.77	14.3	ASD-A3-1021- <sup>①</sup>	
	1500		ECMC-E <sup>②</sup> 1315 <sup>③④</sup>	7.16	21.5	ASD-A3-1521- <sup>①</sup>		
	2000 / 3000 rpm	Three-phase	2000	ECMC-E <sup>②</sup> 1320 <sup>③④</sup>	9.55	28.7	ASD-A3-2023- <sup>①</sup>	
			2000	ECMC-E <sup>②</sup> 1820 <sup>③④</sup>	9.55	28.7		
			3000	ECMC-E <sup>②</sup> 1830 <sup>③④</sup>	14.32	43	ASD-A3-3023- <sup>①</sup>	
	1500 / 3000 rpm		3000	ECMC-F <sup>②</sup> 1830 <sup>③④</sup>	19.10	57.3		
High inertia			1500 / 3000 rpm	Single- / three-phase	850	ECMC-F <sup>②</sup> 1308 <sup>③④</sup>		5.41
	Three-phase			1300	ECMC-F <sup>②</sup> 1313 <sup>③④</sup>	8.34	23.3	ASD-A3-2023- <sup>①</sup>
		1800	ECMC-F <sup>②</sup> 1318 <sup>③④</sup>	11.48	28.7			

## Note:

- In the servo motor model name, <sup>②</sup> represents the encoder type; <sup>③</sup> represents the brake or keyway / oil seal type; <sup>④</sup> represents the shaft diameter and connector type; and <sup>⑤</sup> represents the special code.
- In the servo drive model name, <sup>①</sup> represents the model type.

1

### 1.3.2 400V models

ECM-B3 series servo motor

1

Servo motor model							Servo drive model
Inertia	Rated / Max. speed	Power	Output (W)	Model name	Rated torque (N·m)	Max. torque (N·m)	Model name
Medium inertia	3000 / 6000 rpm	Three-phase	400	ECM-B3M-J <sup>②</sup> 0604 <sup>③④⑤</sup>	1.27	4.45	ASD-A3-0443- <sup>①</sup>
			750	ECM-B3M-J <sup>②</sup> 0807 <sup>③④⑤</sup>	2.4	8.4	ASD-A3-0743- <sup>①</sup>
			1000	ECM-B3M-J <sup>②</sup> 1010 <sup>③④⑤</sup>	3.18	9.54	ASD-A3-1043- <sup>①</sup>
			1500	ECM-B3M-J <sup>②</sup> 1015 <sup>③④⑤</sup>	4.77	14.31	ASD-A3-1543- <sup>①</sup>
			2000	ECM-B3M-J <sup>②</sup> 1020 <sup>③④⑤</sup>	6.37	19.11	ASD-A3-2043- <sup>①</sup>
	2000 / 3000 rpm		1000	ECM-B3M-K <sup>②</sup> 1310 <sup>③④⑤</sup>	4.77	14.3	ASD-A3-1043- <sup>①</sup>
			1500	ECM-B3M-K <sup>②</sup> 1315 <sup>③④⑤</sup>	7.16	21.48	ASD-A3-1543- <sup>①</sup>
			2000	ECM-B3M-K <sup>②</sup> 1320 <sup>③④⑤</sup>	9.55	28.65	ASD-A3-2043- <sup>①</sup>
High inertia	1500 / 4000 rpm	850	ECM-B3H-L <sup>②</sup> 1308 <sup>③④⑤</sup>	5.39	16.17	ASD-A3-1043- <sup>①</sup>	
		1300	ECM-B3H-L <sup>②</sup> 1313 <sup>③④⑤</sup>	8.34	25.02	ASD-A3-1543- <sup>①</sup>	
		1800	ECM-B3H-L <sup>②</sup> 1318 <sup>③④⑤</sup>	11.5	34.5	ASD-A3-2043- <sup>①</sup>	
Medium inertia	2000 / 3000 rpm	2000	ECM-B3M-K <sup>②</sup> 1820 <sup>③④⑤</sup>	9.55	28.65	ASD-A3-2043- <sup>①</sup>	
	1500 / 3000 rpm	3000	ECM-B3M-L <sup>②</sup> 1830 <sup>③④⑤</sup>	19.1	57.29	ASD-A3-3043- <sup>①</sup>	
	1500 / 4000 rpm	4500	ECM-B3M-L <sup>②</sup> 1845 <sup>③④⑤</sup>	28.65	71.6	ASD-A3-4543- <sup>①</sup>	
		5500	ECM-B3M-L <sup>②</sup> 1855 <sup>③④⑤</sup>	35.01	105	ASD-A3-5543- <sup>①</sup>	
		7500	ECM-B3M-L <sup>②</sup> 1875 <sup>③④⑤</sup>	47.75	119	ASD-A3-7543- <sup>①</sup>	
		11000	ECM-B3M-L <sup>②</sup> 2221B <sup>③④⑤</sup>	70.03	175	ASD-A3-1B43- <sup>①</sup>	
		15000	ECM-B3M-L <sup>②</sup> 2221F <sup>③④⑤</sup>	95.49	238.5	ASD-A3-1F43- <sup>①</sup>	

Note:

1. In the servo motor model name, <sup>②</sup> represents the encoder type; <sup>③</sup> represents the brake or keyway / oil seal type; <sup>④</sup> represents the shaft diameter and connector type; and <sup>⑤</sup> represents the special code.
2. In the servo drive model name, <sup>①</sup> represents the model type.

## 1.4 Description of the drive interface

### 1.4.1 220V models: A3-L

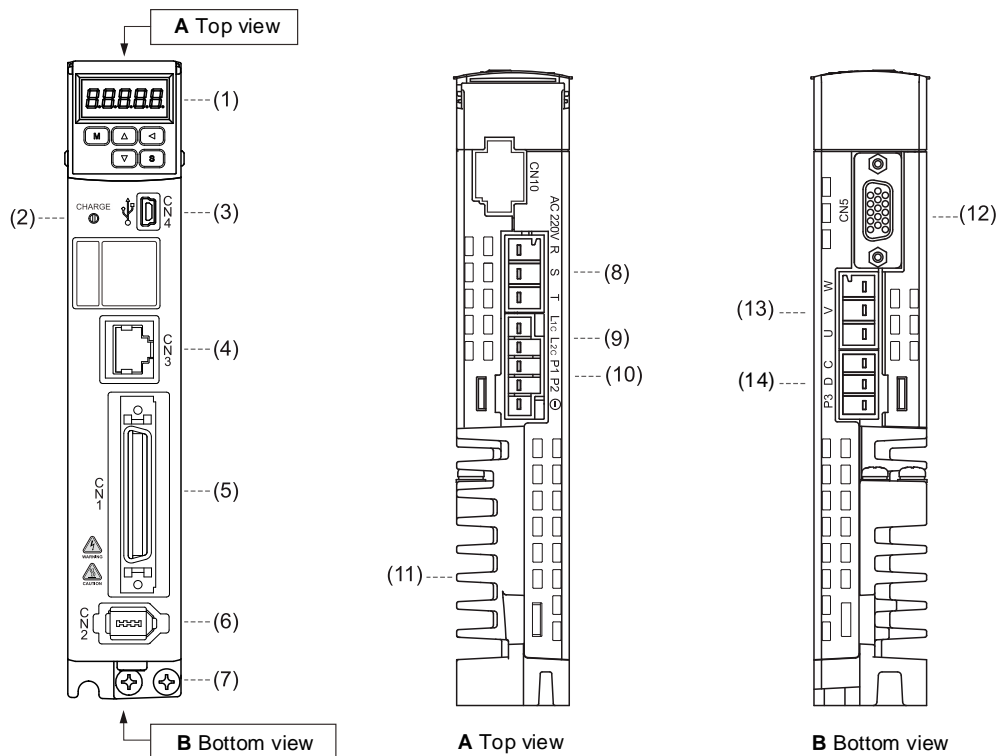

No.	Name	Description
(1)	-	7-segment display.
(2)	CHARGE	Power indicator.
(3)	CN4	Mini USB connector: connects to PC.
(4)	CN3	RS-485 connector: connects to the controller and communication ports.
(5)	CN1	I/O signal interface: connects to PLC or controls I/O.
(6)	CN2	Encoder connector: connects to the encoder.
(7)	Grounding screws	Connects to the ground wire for the power and servo motor.
(8)	RST*	Main circuit power input terminal: connects to commercial power supply (200 - 230 V <sub>AC</sub> , 50 / 60 Hz).
(9)	L <sub>1C</sub> *, L <sub>2C</sub> *	Control circuit power input terminal: connects to single-phase power supply (200 - 230 V <sub>AC</sub> , 50 / 60 Hz).
(10)	P1*, P2*	Coming soon.
(11)	Heat sink	For securing the servo drive and heat dissipation.
(12)	CN5	Position feedback connector.
(13)	UVW*	Servo drive current output: connects to the motor power connector (U, V, W). Do not connect to the main circuit power. Incorrect wiring will cause damage to the servo drive.
(14)	Regenerative resistor* (P3, D, C, ⊖)	When an external regenerative resistor is used: P3 and C contacts connect to the resistor; P3 and D contacts are left open. When the built-in regenerative resistor is used: P3 and C contacts are left open; P3 and D contacts are short-circuited (connected). When an external regenerative unit is used: P3 and ⊖ contacts connect to the regenerative unit; P3 & C contacts and P3 & D contacts are left open.

Note: the types of terminal blocks with \* vary with the models, but this does not affect their pin assignments and functions.

1.4.2 220V models: A3-M

1

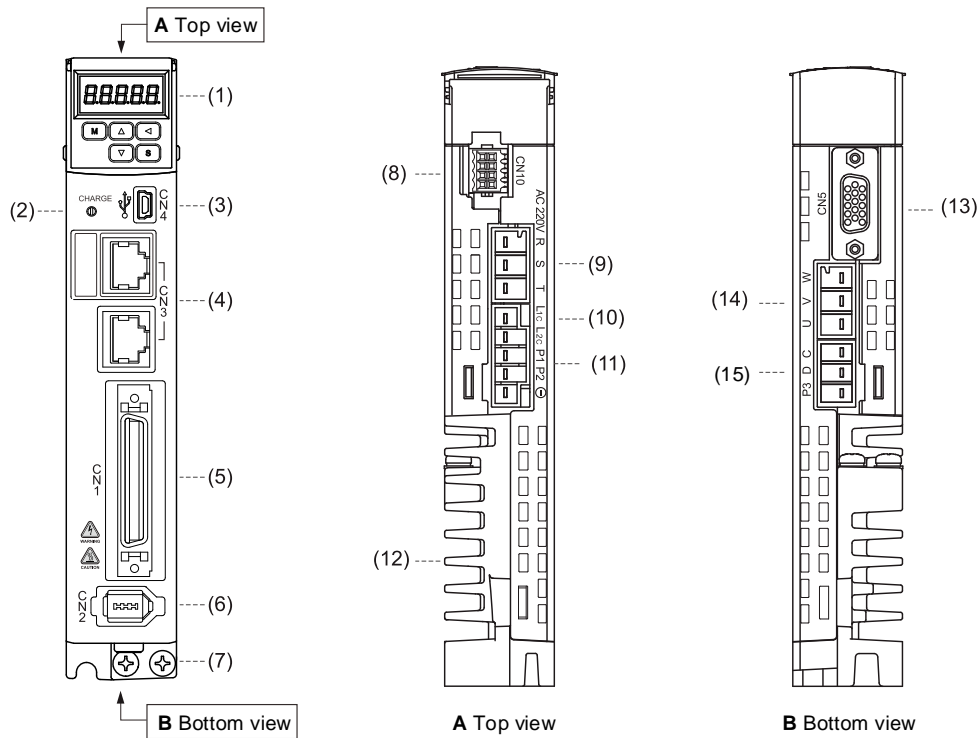

No.	Name	Description
(1)	-	7-segment display.
(2)	CHARGE	Power indicator.
(3)	CN4	Mini USB connector: connects to PC.
(4)	CN3	RS-485 and CANopen connector: connects to the controller and CANopen communication ports.
(5)	CN1	I/O signal interface: connects to PLC or controls I/O.
(6)	CN2	Encoder connector: connects to the encoder.
(7)	Grounding screws	Connects to the ground wire for the power and servo motor.
(8)	CN10	STO (Safe Torque Off).
(9)	RST*	Main circuit power input terminal: connects to commercial power supply (200 - 230 V <sub>AC</sub> , 50 / 60 Hz).
(10)	L1C*, L2C*	Control circuit power input terminal: connects to single-phase power supply (200 - 230 V <sub>AC</sub> , 50 / 60 Hz).
(11)	P1*, P2*	Coming soon.
(12)	Heat sink	For securing the servo drive and heat dissipation.
(13)	CN5	Position feedback connector.
(14)	UVW*	Servo drive current output: connects to the motor power connector (U, V, W). Do not connect to the main circuit power. Incorrect wiring will cause damage to the servo drive.
(15)	Regenerative resistor* (P3, D, C, ⊖)	When an external regenerative resistor is used: P3 and C contacts connect to the resistor; P3 and D contacts are left open. When the built-in regenerative resistor is used: P3 and C contacts are left open; P3 and D contacts are short-circuited (connected). When an external regenerative unit is used: P3 and ⊖ contacts connect to the regenerative unit; P3 & C contacts and P3 & D contacts are left open.

Note: the types of terminal blocks with \* vary with the models, but this does not affect their pin assignments and functions.

1.4.3 220V models: A3-F

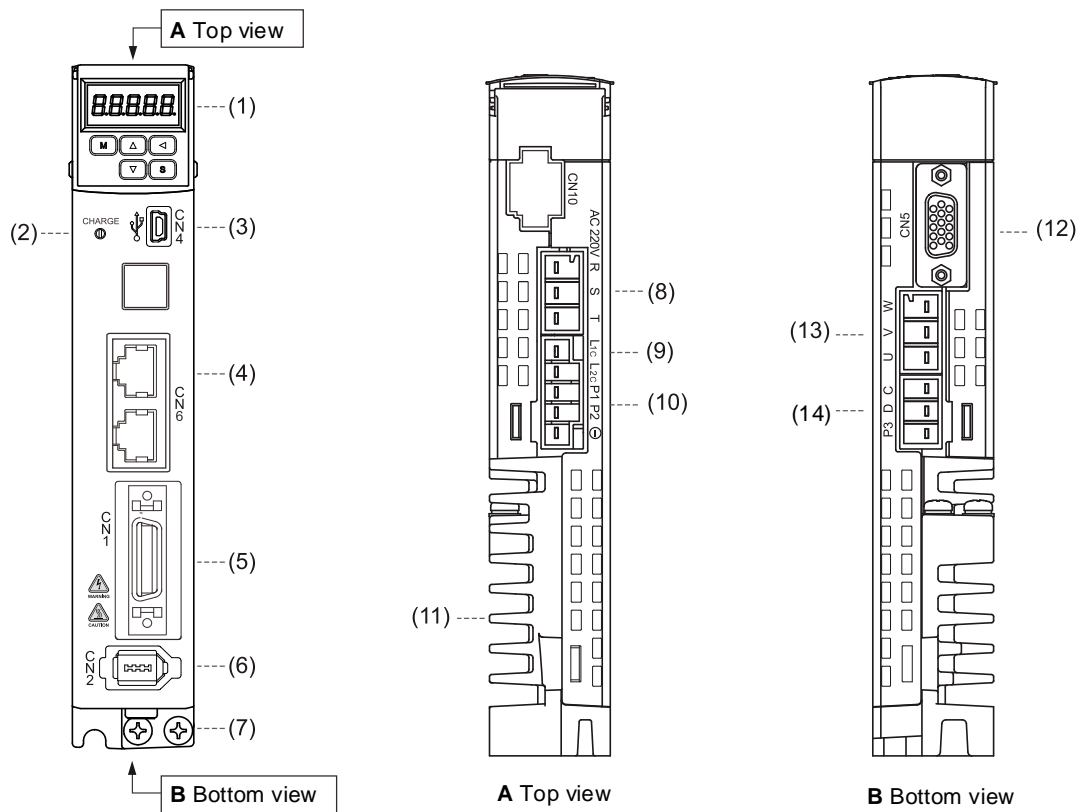

No.	Name	Description
(1)	-	7-segment display.
(2)	CHARGE	Power indicator.
(3)	CN4	Mini USB connector: connects to PC.
(4)	CN6	DMCNET high-speed communication port connector.
(5)	CN1	I/O signal interface: connects to PLC or controls I/O.
(6)	CN2	Encoder connector: connects to the encoder.
(7)	Grounding screws	Connects to the ground wire for the power and servo motor.
(8)	RST*	Main circuit power input terminal: connects to commercial power supply (200 - 230 V <sub>AC</sub> , 50 / 60 Hz).
(9)	L <sub>1C</sub> *, L <sub>2C</sub> *	Control circuit power input terminal: connects to single-phase power supply (200 - 230 V <sub>AC</sub> , 50 / 60 Hz).
(10)	P1*, P2*	Coming soon.
(11)	Heat sink	For securing the servo drive and heat dissipation.
(12)	CN5	Position feedback connector.
(13)	UVW*	Servo drive current output: connects to the motor power connector (U, V, W). Do not connect to the main circuit power. Incorrect wiring will cause damage to the servo drive.
(14)	Regenerative resistor* (P3, D, C, ⊖)	When an external regenerative resistor is used: P3 and C contacts connect to the resistor; P3 and D contacts are left open. When the built-in regenerative resistor is used: P3 and C contacts are left open; P3 and D contacts are short-circuited (connected). When an external regenerative unit is used: P3 and ⊖ contacts connect to the regenerative unit; P3 & C contacts and P3 & D contacts are left open.

Note: the types of terminal blocks with \* vary with the models, but this does not affect their pin assignments and functions.

1.4.4 220V models: A3-E

1

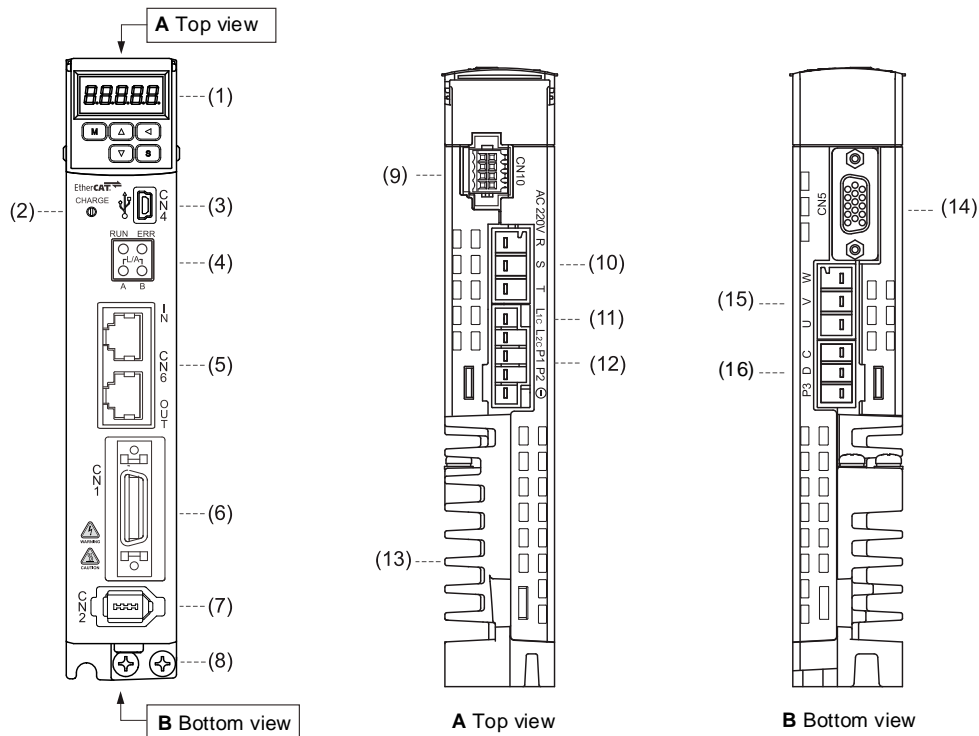

No.	Name	Description
(1)	-	7-segment display.
(2)	CHARGE	Power indicator.
(3)	CN4	Mini USB connector: connects to PC.
(4)	EtherCAT indicators	EtherCAT status indicators.
(5)	CN6	EtherCAT high-speed communication port connector.
(6)	CN1	I/O signal interface: connects to PLC or controls I/O.
(7)	CN2	Encoder connector: connects to the encoder.
(8)	Grounding screws	Connects to the ground wire for the power and servo motor.
(9)	CN10	STO (Safe Torque Off).
(10)	RST*	Main circuit power input terminal: connects to commercial power supply (200 - 230 V <sub>AC</sub> , 50 / 60 Hz).
(11)	L1c*, L2c*	Control circuit power input terminal: connects to single-phase power supply (200 - 230 V <sub>AC</sub> , 50 / 60 Hz).
(12)	P1*, P2*	Coming soon.
(13)	Heat sink	For securing the servo drive and heat dissipation.
(14)	CN5	Position feedback connector.
(15)	UVW*	Servo drive current output: connects to the motor power connector (U, V, W). Do not connect to the main circuit power. Incorrect wiring will cause damage to the servo drive.
(16)	Regenerative resistor* (P3, D, C, ⊖)	When an external regenerative resistor is used: P3 and C contacts connect to the resistor; P3 and D contacts are left open. When the built-in regenerative resistor is used: P3 and C contacts are left open; P3 and D contacts are short-circuited (connected). When an external regenerative unit is used: P3 and ⊖ contacts connect to the regenerative unit; P3 & C contacts and P3 & D contacts are left open.

Note: the types of terminal blocks with \* vary with the models, but this does not affect their pin assignments and functions.

1.4.5 400V models: A3-L

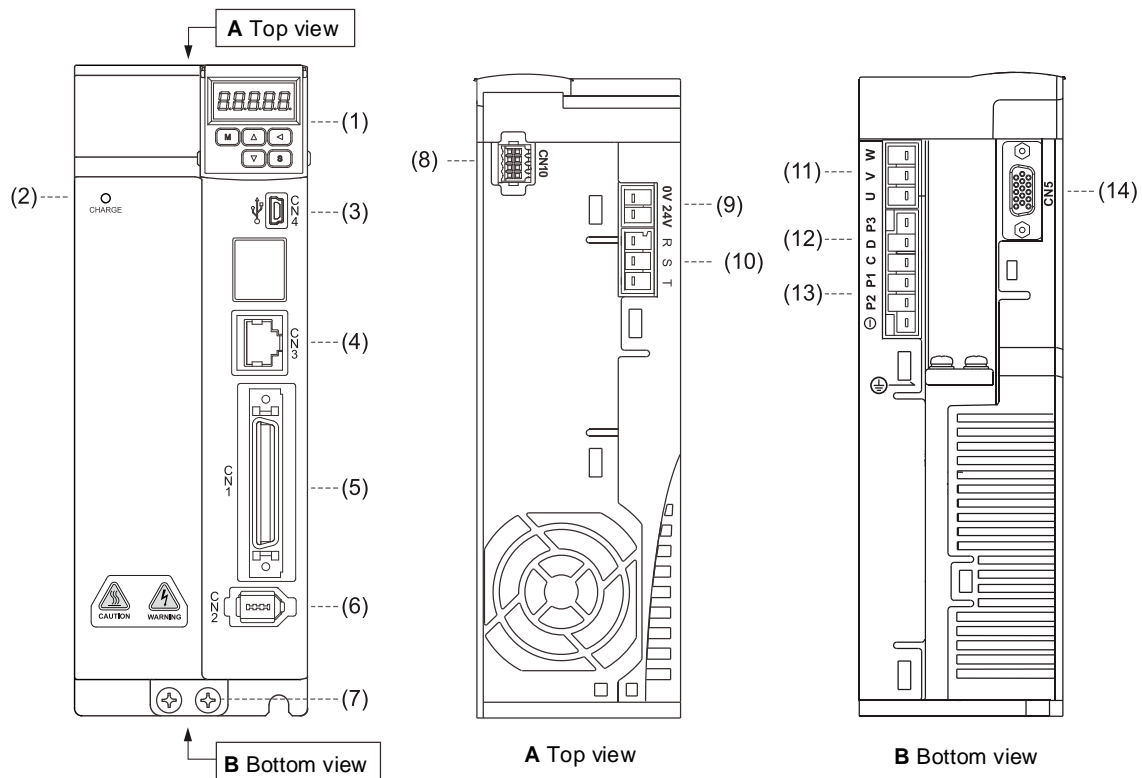

No.	Name	Description
(1)	-	7-segment display.
(2)	CHARGE	Power indicator.
(3)	CN4	Mini USB connector: connects to PC.
(4)	CN3	RS-485 connector: connects to the controller and communication ports.
(5)	CN1	I/O signal interface: connects to PLC or controls I/O.
(6)	CN2	Encoder connector: connects to the encoder.
(7)	Grounding screws	Connects to the ground wire for the power and servo motor.
(8)	CN10	STO (Safe Torque Off).
(9)	24V*, 0V*	Control circuit power input terminal: connects to 24 V <sub>DC</sub> ±10% power supply.
(10)	RST*	Main circuit power input terminal: connects to commercial power supply (380 - 480 V <sub>AC</sub> , 50 / 60 Hz).
(11)	UVW*	Servo drive current output: connects to the motor power connector (U, V, W). Do not connect to the main circuit power. Incorrect wiring will cause damage to the servo drive.
(12)	Regenerative resistor* (P3, D, C, ⊖)	When an external regenerative resistor is used: P3 and C contacts connect to the resistor; P3 and D contacts are left open. When the built-in regenerative resistor is used: P3 and C contacts are left open; P3 and D contacts are short-circuited (connected). When an external regenerative unit is used: P3 and ⊖ contacts connect to the regenerative unit; P3 & C contacts and P3 & D contacts are left open.
(13)	P1*, P2*	Coming soon.
(14)	CN5	Position feedback connector.

Note: the types of terminal blocks with \* vary with the models, but this does not affect their pin assignments and functions.



1.4.6 400V models: A3-M

1

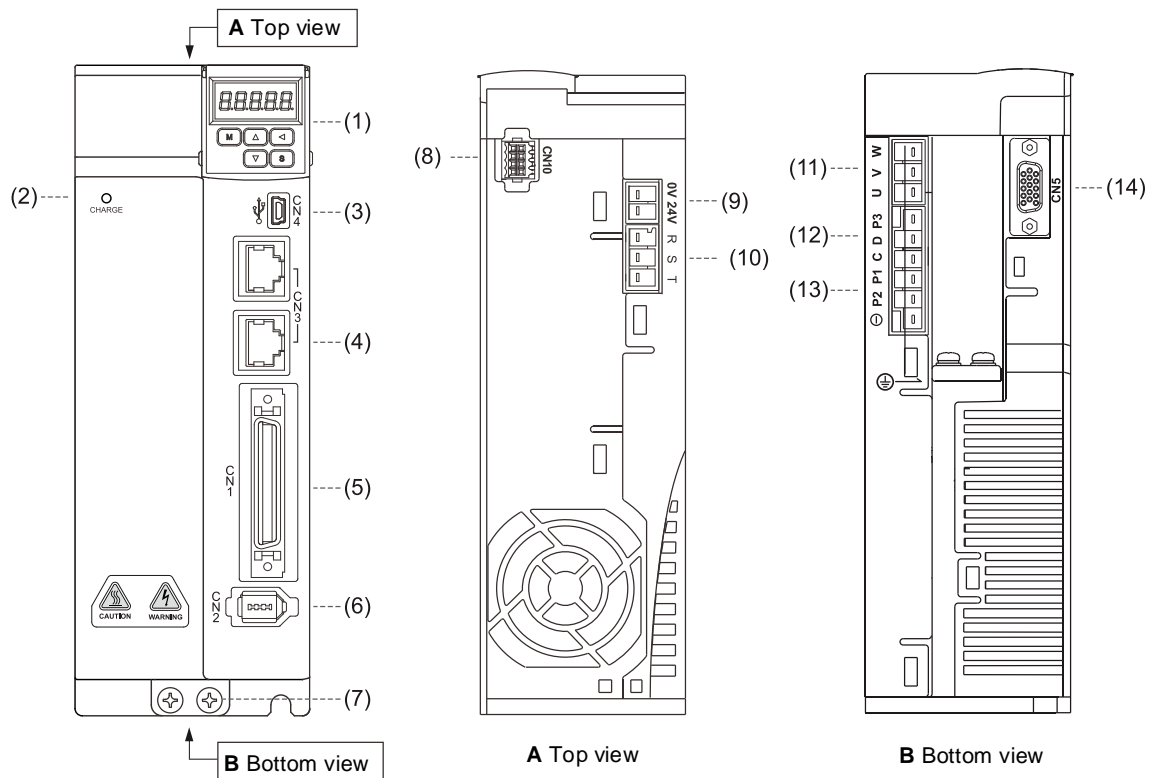

No.	Name	Description
(1)	-	7-segment display.
(2)	CHARGE	Power indicator.
(3)	CN4	Mini USB connector: connects to PC.
(4)	CN3	RS-485 and CANopen connector: connects to the controller and CANopen communication ports.
(5)	CN1	I/O signal interface: connects to PLC or controls I/O.
(6)	CN2	Encoder connector: connects to the encoder.
(7)	Grounding screws	Connects to the ground wire for the power and servo motor.
(8)	CN10	STO (Safe Torque Off).
(9)	24V*, 0V*	Control circuit power input terminal: connects to 24 V <sub>DC</sub> ±10% power supply.
(10)	RST*	Main circuit power input terminal: connects to commercial power supply (380 - 480 V <sub>AC</sub> , 50 / 60 Hz).
(11)	UVW*	Servo drive current output: connects to the motor power connector (U, V, W). Do not connect to the main circuit power. Incorrect wiring will cause damage to the servo drive.
(12)	Regenerative resistor* (P3, D, C, ⊖)	When an external regenerative resistor is used: P3 and C contacts connect to the resistor; P3 and D contacts are left open. When the built-in regenerative resistor is used: P3 and C contacts are left open; P3 and D contacts are short-circuited (connected). When an external regenerative unit is used: P3 and ⊖ contacts connect to the regenerative unit; P3 & C contacts and P3 & D contacts are left open.
(13)	P1*, P2*	Coming soon.
(14)	CN5	Position feedback connector.

Note: the types of terminal blocks with \* vary with the models, but this does not affect their pin assignments and functions.

1.4.7 400V models: A3-F

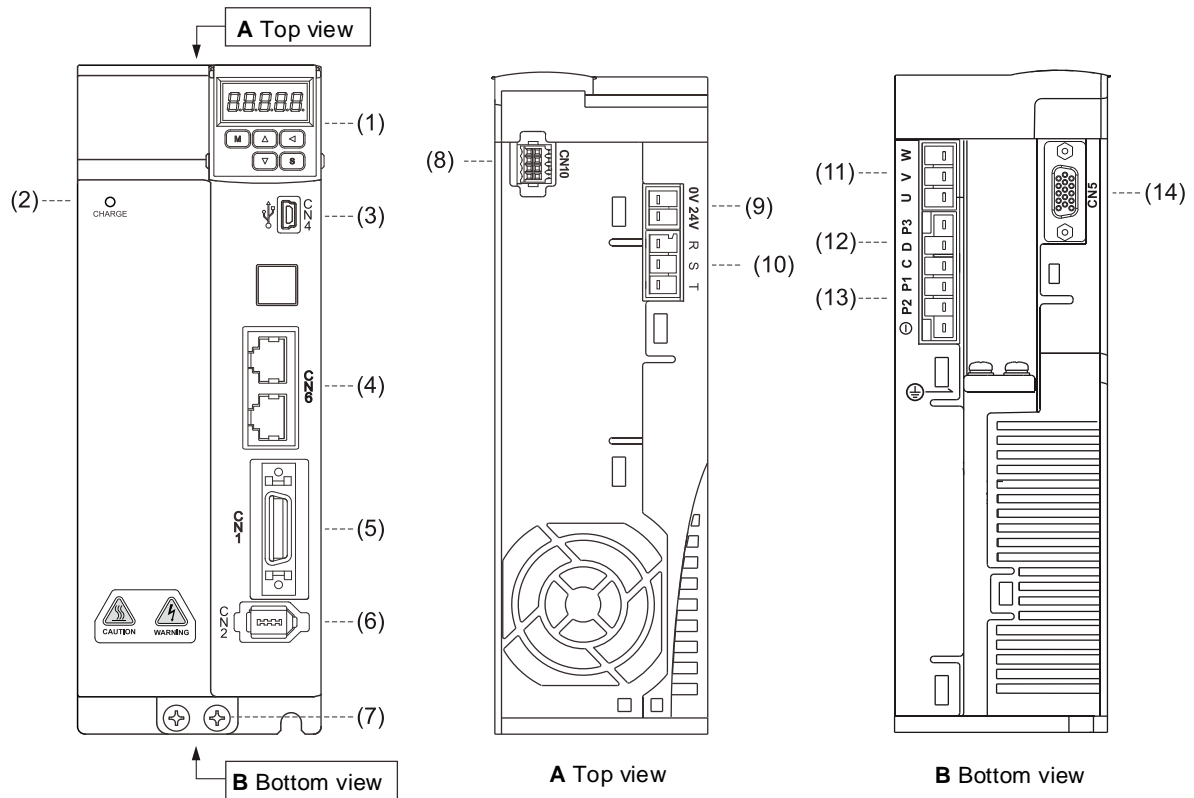

No.	Name	Description
(1)	-	7-segment display.
(2)	CHARGE	Power indicator.
(3)	CN4	Mini USB connector: connects to PC.
(4)	CN6	DMCNET high-speed communication port connector.
(5)	CN1	I/O signal interface: connects to PLC or controls I/O.
(6)	CN2	Encoder connector: connects to the encoder.
(7)	Grounding screws	Connects to the ground wire for the power and servo motor.
(8)	CN10	STO (Safe Torque Off).
(9)	24V*, 0V*	Control circuit power input terminal: connects to 24 V <sub>DC</sub> ±10% power supply
(10)	RST*	Main circuit power input terminal: connects to commercial power supply (380 - 480 V <sub>AC</sub> , 50 / 60 Hz).
(11)	UVW*	Servo drive current output: connects to the motor power connector (U, V, W). Do not connect to the main circuit power. Incorrect wiring will cause damage to the servo drive.
(12)	Regenerative resistor* (P3, D, C, ⊖)	When an external regenerative resistor is used: P3 and C contacts connect to the resistor; P3 and D contacts are left open. When the built-in regenerative resistor is used: P3 and C contacts are left open; P3 and D contacts are short-circuited (connected). When an external regenerative unit is used: P3 and ⊖ contacts connect to the regenerative unit; P3 & C contacts and P3 & D contacts are left open.
(13)	P1*, P2*	Coming soon.
(14)	CN5	Position feedback connector.

Note: the types of terminal blocks with \* vary with the models, but this does not affect their pin assignments and functions.

1

1.4.8 400V models: A3-E

1

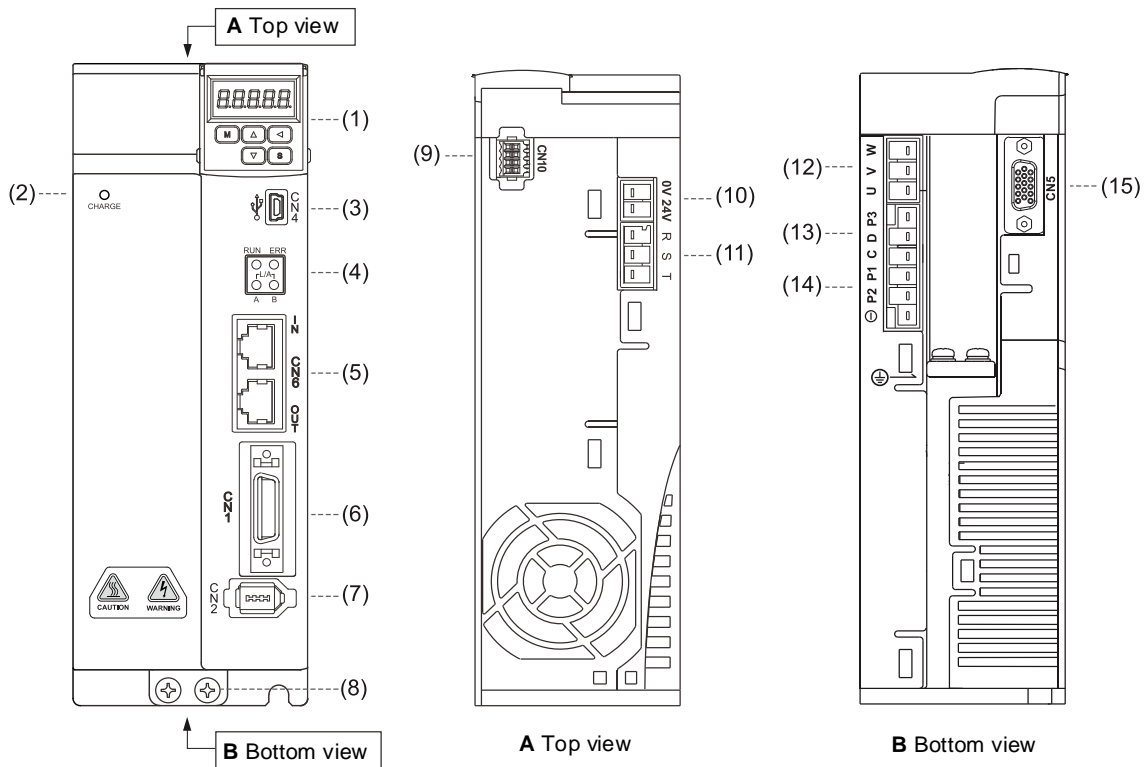

No.	Name	Description
(1)	-	7-segment display.
(2)	CHARGE	Power indicator.
(3)	CN4	Mini USB connector: connects to PC.
(4)	EtherCAT indicators	EtherCAT status indicators
(5)	CN6	EtherCAT high-speed communication port connector.
(6)	CN1	I/O signal interface: connects to PLC or controls I/O.
(7)	CN2	Encoder connector: connects to the encoder.
(8)	Grounding screws	Connects to the ground wire for the power and servo motor.
(9)	CN10	STO (Safe Torque Off).
(10)	24V*, 0V*	Control circuit power input terminal: connects to 24 V <sub>DC</sub> ±10% power supply.
(11)	RST*	Main circuit power input terminal: connects to commercial power supply (380 - 480 V <sub>AC</sub> , 50 / 60 Hz).
(12)	UVW*	Servo drive current output: connects to the motor power connector (U, V, W). Do not connect to the main circuit power. Incorrect wiring will cause damage to the servo drive.
(13)	Regenerative resistor* (P3, D, C, ⊖)	When an external regenerative resistor is used: P3 and C contacts connect to the resistor; P3 and D contacts are left open. When the built-in regenerative resistor is used: P3 and C contacts are left open; P3 and D contacts are short-circuited (connected). When an external regenerative unit is used: P3 and ⊖ contacts connect to the regenerative unit; P3 & C contacts and P3 & D contacts are left open.
(14)	P1*, P2*	Coming soon.
(15)	CN5	Position feedback connector.

Note: the types of terminal blocks with \* vary with the models, but this does not affect their pin assignments and functions.

# Installation

# 2

Please follow the instructions in this chapter during installation. This chapter includes information about the circuit breaker, fuse, EMI filter selection, and the regenerative resistor.

---

2.1	Ambient storage conditions	2-2
2.2	Ambient installation conditions	2-2
2.3	Mounting direction and space	2-5
2.4	Safety precautions for using motors	2-8
2.4.1	Troubleshooting for the motor operation and status	2-10
2.4.2	Mounting directions and precautions for the servo motor	2-11
2.4.3	Precautions for using servo motor with oil seal	2-12
2.4.4	Precautions for installing servo motor accessories	2-13
2.4.5	Oil and water prevention measures for the servo motor	2-15
2.4.6	Measures to suppress temperature increase of the servo motor	2-16
2.5	Specifications for the circuit breaker, magnetic contactor and fuse	2-17
2.6	Ferrite ring	2-20
2.7	Installation requirements for EMC	2-22
2.7.1	EMI filters	2-24
2.8	Selecting the regenerative resistor	2-26
2.9	The use of braking	2-34
2.10	The use of cable	2-36

## 2

## 2.1 Ambient storage conditions

Before installation, this product must be kept in the shipping carton. In order to retain the warranty coverage and for maintenance, follow these instructions for storage. While the product is temporarily not in use:

- Store the product in an ambient temperature range of -20°C (-4°F) to +65°C (149°F).
- Store the product in a relative humidity range of 0% to 90% RH (non-condensing).
- Avoid storing the product in an environment containing corrosive gas.

## 2.2 Ambient installation conditions

**A3 servo drive:** the environment should be free of devices that generate excessive heat; no water, vapor, dust, and oily dust; no corrosive and inflammable gas or liquids; no airborne dust or metal particles; and the environment should be solid without vibration and free of electromagnetic interference.



**Motor:** the ambient temperature for the location of the ECM-A3 and ECOMC motors should be between 0°C (32°F) and 40°C (104°F). The ambient temperature for the location of the ECM-B3 motors should be between -20°C (32°F) and 60°C (104°F)\*. The environment should be free of devices that generate excessive heat; no water, vapor, dust, and oily dust; no corrosive and inflammable gas or liquids; no airborne dust or metal particles.

Note: if the ambient temperature is over 40°C, refer to Section A.3.3 Power derating curves of the B3 motor.

**220V Models**

The ambient temperature of the operating environment for the 220V servo drive is between 0°C (32°F) and 55°C (131°F). If the temperature is over 45°C (113°F), place the product in a well-ventilated environment. During long-term operation, the suggested temperature of the operating environment should be under 45°C (113°F) to ensure the servo drive’s performance. Mount the product vertically in the distribution board (see the illustration of the correct mounting direction in Section 2.3) and install a fan on the board for heat dissipation. Ensure that the temperature for the clearance of 5 cm (1.97 inches) beneath and on both sides of the servo drive is kept under 55°C (131°F), and the servo drive must be kept clear of heat sources. Moreover, the airflow velocity at the measuring point which is 10 mm (0.4 inches) above the servo drive of 400 W (or below) has to be greater than 0.5 m/s; the airflow velocity at the measuring point which is 10 mm (0.4 inches) above the servo drive of 750 W (or above) has to be greater than 1 m/s. Make sure the size of the distribution board and its ventilation condition can prevent the internal electrical devices from overheating. Besides, check if the vibration of the machine affects the electrical devices of the distribution board.

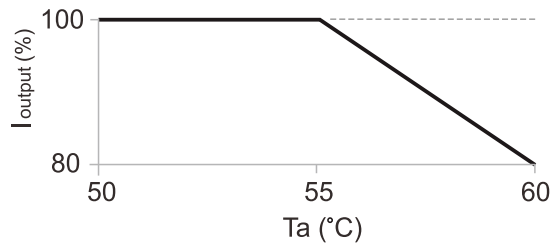
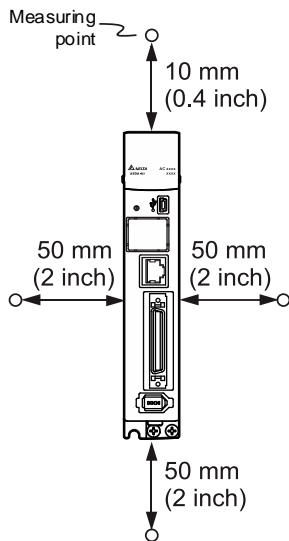

I output (%) is the output current percentage;  
Ta (°C) is the operating temperature

Note: the maximum operating temperature for the models of 750 W - 3 kW is up to 60°C (140°F), but the output current declines as shown above; the maximum operating temperature for the models of 400 W (or below) and 4.5 kW (or above) is only up to 55°C (131°F).

**400V Models**

2

The ambient temperature of the operating environment for the 400V servo drive is between 0°C (32°F) and 55°C (131°F). When operating the 3 kW models in an ambient temperature between 50°C (122°F) and 55°C (131°F), reduce the maximum load to 80%. If the temperature is over 45°C (113°F), place the product in a well-ventilated environment. During long-term operation, the suggested temperature of the operating environment should be under 45°C (113°F) to ensure the servo drive's performance. Mount the product vertically in the distribution board (see the illustration of the correct mounting direction in Section 2.3) and install a fan on the board for heat dissipation. Ensure that the temperature for the clearance of 5 cm (1.97 inches) beneath and on both sides of the servo drive is kept under 50°C (122°F), and the servo drive must be kept clear of heat sources. Moreover, the airflow velocity at the measuring point which is 10 mm (0.4 inches) above the servo drive has to be greater than 1 m/s. Make sure the size of the distribution board and its ventilation condition can prevent the internal electrical devices from overheating. Besides, check if the vibration of the machine affects the electrical devices of the distribution board.

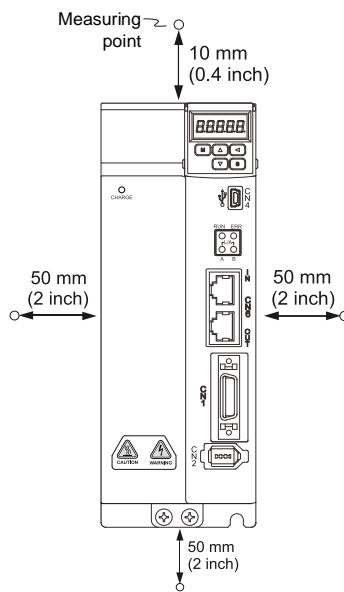

## 2.3 Mounting direction and space

### Important:

- Mount the servo drive in the correct direction according to the following illustrations with the base of the heat sink vertically on the wall. Incorrect mounting direction may result in malfunction.
- For better ventilation and cooling, allow sufficient clearance space between the AC servo drive and the adjacent objects and the wall, or overheating may result in machine malfunction.
- Do not block the ventilation holes of the servo drive, and do not mount the servo drive in the incorrect direction, or it may result in machine malfunction.

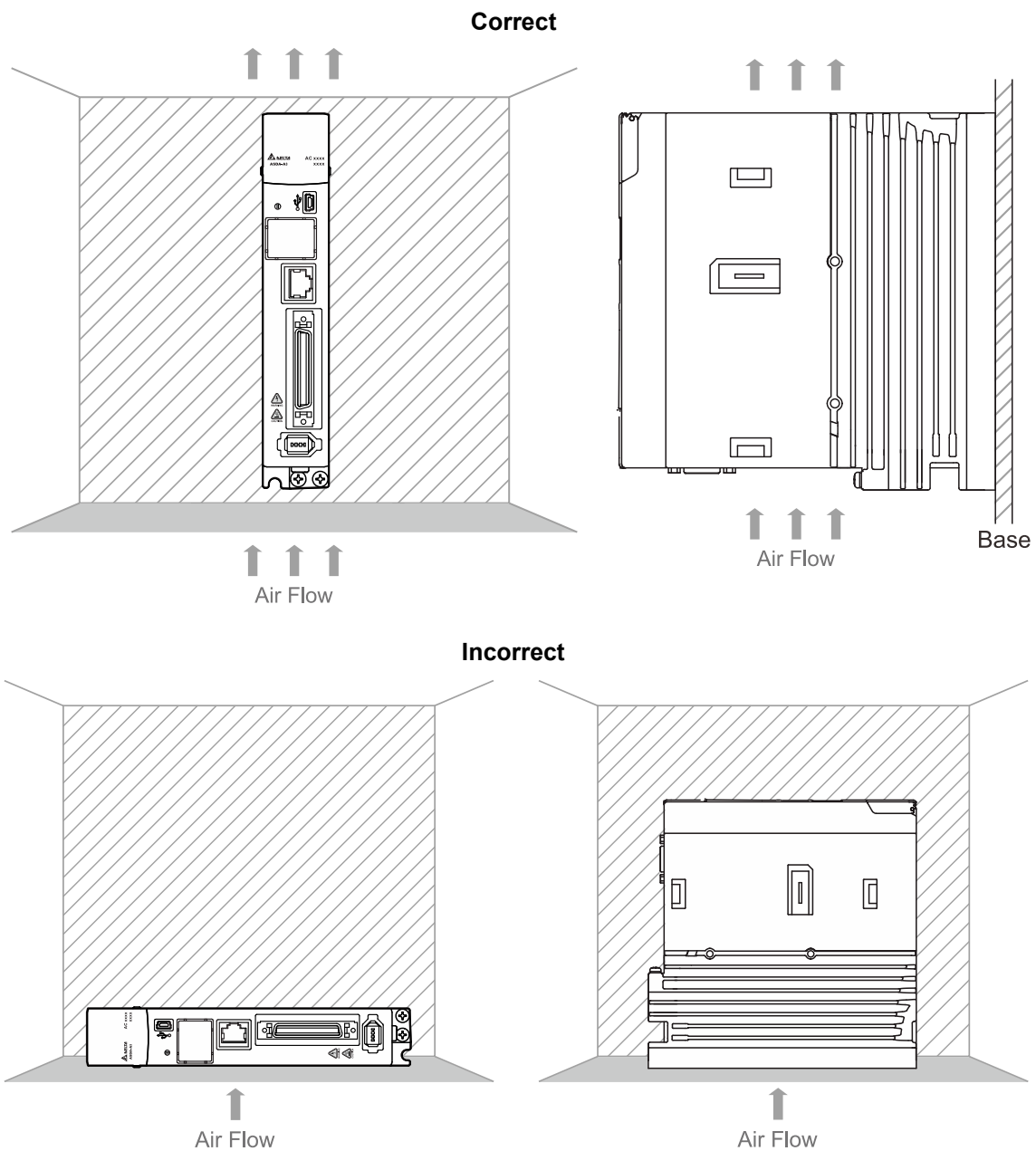



# 2

## Heat dissipation requirements

In order to have adequate air flow for ventilation, follow the suggested clearances when installing one or more servo drives. The servo drive generates heat, therefore be aware of the minimum distance (d) and the ambient temperature factor when installing multiple servo drives (refer to the following diagrams). Avoid mounting one servo drive above one another. Keep the bottom of the servo drive clear because the generated heat rises and causes higher temperature for the drives mounted above.

Note: the following diagrams are not accurately scaled. Refer to the annotations on the diagrams.

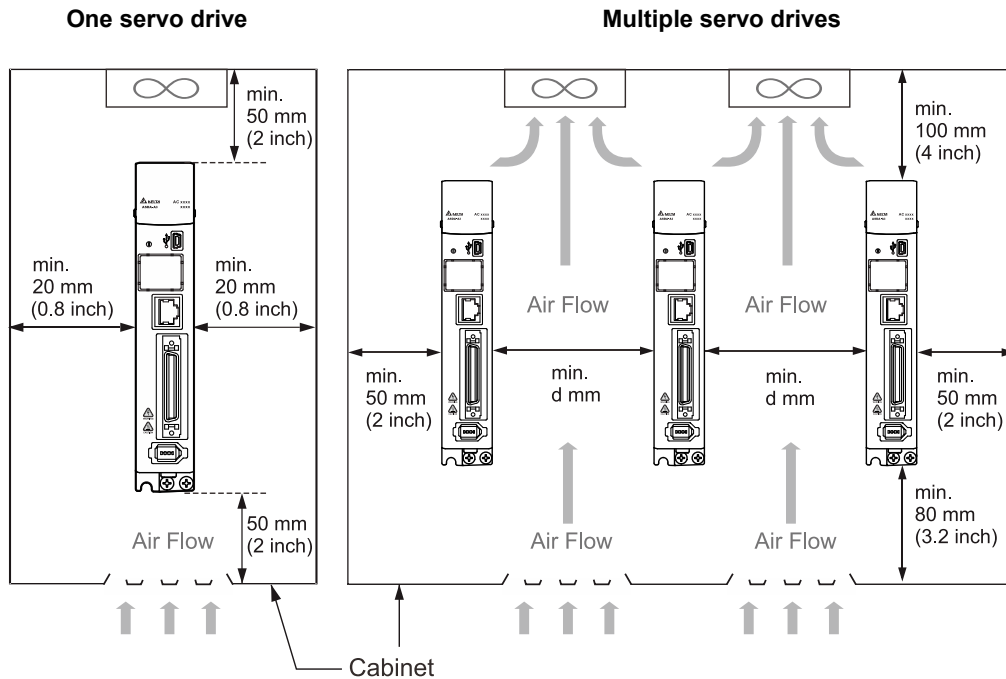

Servo drive model	Cooling method	Operating temperature (Ta) corresponding to the minimum distance (d) *Considering the assembly tolerances, the servo drive requires a minimum clearance of 1 mm										
ASD-A3-0121-□ ASD-A3-0221-□ ASD-A3-0421-□	Air convection cooling	<table border="1"> <caption>Data for Air convection cooling graph</caption> <thead> <tr> <th>d (mm)</th> <th>Ta (°C)</th> </tr> </thead> <tbody> <tr><td>1</td><td>35</td></tr> <tr><td>5</td><td>45</td></tr> <tr><td>10</td><td>50</td></tr> <tr><td>20</td><td>55</td></tr> </tbody> </table>	d (mm)	Ta (°C)	1	35	5	45	10	50	20	55
d (mm)	Ta (°C)											
1	35											
5	45											
10	50											
20	55											
ASD-A3-0721-□ ASD-A3-1021-□ ASD-A3-1521-□ ASD-A3-2023-□ ASD-A3-3023-□	Natural cooling plus forced cooling	<table border="1"> <caption>Data for Natural cooling plus forced cooling graph</caption> <thead> <tr> <th>d (mm)</th> <th>Ta (°C)</th> </tr> </thead> <tbody> <tr><td>1</td><td>45</td></tr> <tr><td>5</td><td>50</td></tr> <tr><td>10</td><td>55</td></tr> <tr><td>20</td><td>60</td></tr> </tbody> </table>	d (mm)	Ta (°C)	1	45	5	50	10	55	20	60
d (mm)	Ta (°C)											
1	45											
5	50											
10	55											
20	60											

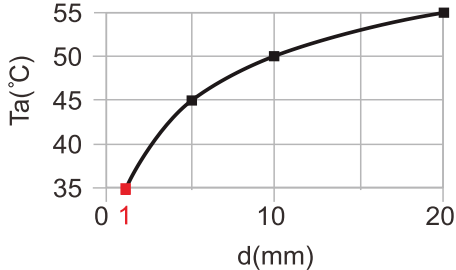
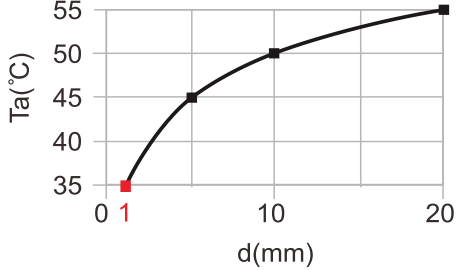
Servo drive model	Cooling method	Operating temperature (Ta) corresponding to the minimum distance (d) *Considering the assembly tolerances, the servo drive requires a minimum clearance of 1 mm										
ASD-A3-4523-□ ASD-A3-5523-□ ASD-A3-7523-□ ASD-A3-1B23-□ ASD-A3-1F23-□	Natural cooling plus forced cooling	 <table border="1"> <caption>Data for Graph 1</caption> <thead> <tr> <th>d (mm)</th> <th>Ta (°C)</th> </tr> </thead> <tbody> <tr> <td>1</td> <td>35</td> </tr> <tr> <td>5</td> <td>45</td> </tr> <tr> <td>10</td> <td>50</td> </tr> <tr> <td>20</td> <td>55</td> </tr> </tbody> </table>	d (mm)	Ta (°C)	1	35	5	45	10	50	20	55
d (mm)	Ta (°C)											
1	35											
5	45											
10	50											
20	55											
ASD-A3-0443-□ ASD-A3-0743-□ ASD-A3-1043-□ ASD-A3-1543-□ ASD-A3-2043-□ ASD-A3-3043-□ ASD-A3-4543-□ ASD-A3-5543-□ ASD-A3-7543-□ ASD-A3-1B43-□ ASD-A3-1F43-□	Natural cooling plus forced cooling	 <table border="1"> <caption>Data for Graph 2</caption> <thead> <tr> <th>d (mm)</th> <th>Ta (°C)</th> </tr> </thead> <tbody> <tr> <td>1</td> <td>35</td> </tr> <tr> <td>5</td> <td>45</td> </tr> <tr> <td>10</td> <td>50</td> </tr> <tr> <td>20</td> <td>55</td> </tr> </tbody> </table>	d (mm)	Ta (°C)	1	35	5	45	10	50	20	55
d (mm)	Ta (°C)											
1	35											
5	45											
10	50											
20	55											

Note:

1. For the 220V models, the maximum operating temperature for the models of 750 W - 3 kW is up to 60°C (140°F), but the output current declines; the maximum operating temperature for the models of 400 W (or below) and 4.5 kW (or above) is only up to 55°C (131°F).
2. When operating the 400V 3 kW models in an ambient temperature between 50°C (122°F) and 55°C (131°F), reduce the maximum load to 80%.

## 2.4 Safety precautions for using motors

The Delta AC servo motor is designed for industrial applications. It is necessary that you fully understand the motor specifications and the operation manual. For your safety and correct use, read the manual, specifications, and precautions for the motor carefully before connecting the motor to any equipment.

The safety precautions are as follows:

### Handling, mounting, and storage

- When removing or installing a servo motor, hold the whole motor instead of holding the cable or only the motor shaft.
- Do not hit the motor shaft. Impact force will damage the shaft and the encoder that is attached at the rear end of the shaft.
- Keep the axial or radial shaft load within the allowable range listed in the specifications.
- The shaft of servo motor is not water- or oil-proof. Do not use, install, or store the servo motor in an environment that contains water, oily liquids, corrosive and inflammable gases, or is with high humidity.
- The material of motor shaft is not rustproof. Although rustproof oil has been applied to the shaft during the manufacturing process, you must check the shaft condition and apply rustproof oil every three months if storing the motor for more than six months.
- Ensure that the environmental conditions for storing the servo motor conform to the specifications in the instruction sheet.
- The encoder attached to the motor is easily damaged; take the necessary steps to avoid electromagnetic interference, vibration, and abnormal temperature changes.
- The magnetic field for placing or installing the motor should be below 10 mT or lower.

### Wiring

- If the current exceeds the maximum current in the specifications, the internal parts of the motor may lose their magnetism. Contact the distributor or local Delta sales representative if this problem occurs.
- Check if the motor wiring and the voltage of the motor brake are correct. Also, make sure that the wiring of the encoder signal and power cables is correct. Incorrect wiring will lead to abnormal operation, malfunction, or damage of the motor.
- To avoid capacitive coupling and noise, isolate the motor power cable from the encoder power and signal cables. Do not connect them to the same circuit.
- The AC servo motor must be correctly grounded.
- The encoder connector must not undergo any high-voltage component test because it will damage the encoder.

- When the motor or brake is undergoing high-voltage component tests, cut off the power supply for the controller. To maintain the product lifespan, do not perform this kind of test unless necessary.

### Operation

- AC servo motor operation is controlled by the servo drive. Do not directly connect a commercial type power supply (100/200V, 50/60 Hz) to the servo motor circuit; otherwise the motor cannot operate normally and may be permanently damaged.
- Follow the motor specifications when using the product. The motor's operation temperature must not exceed the specified range.
- The material of the motor shaft is not rustproof. To ensure a longer motor life, apply rustproof oil during operation.
- The built-in brake is for clamping, not for stopping the motor. Note that the built-in brake is not a device for safely stopping the machine. Install another safety device for stopping the machine. When the built-in brake is clamping the motor, rotation backlash can still occur and the maximum rotation is 1° to 2°. When a motor with a brake is operating, the brake lining sometimes generates a noise (a swishing or clicking sound) caused by the structure of brake module, which is not a malfunction. It will not affect the motor's function.
- When using a servo motor with a brake, do not use the built-in brake for dynamic braking.
- If any odor, noise, smoke, heat, or abnormal vibration occurs during motor operation, stop the motor and turn off the power immediately.

### Others

- Delta servo motors have no user-replaceable parts.
- Do not disassemble the motor or change its parts, or it will void the warranty.
- Do not disassemble the motor by yourself, or it may lead to permanent malfunction or damage.
- Do not splash any water or oil on the product.

2

**2.4.1 Troubleshooting for the motor operation and status**

**When the servo motor makes abnormal noises:**

Possible cause	Checking method	Corrective action
There is a source of vibration in the connecting component.	Check if there is any foreign object, damage, or deformation in the movable parts of the connecting component.	Replace the connecting component (such as the coupling) or contact the manufacturer.
The encoder is subject to excessive vibration / shocks.	<ol style="list-style-type: none"> <li>1. Check if the servo motor has been subject to impact force or vibration which causes damage to the encoder.</li> <li>2. Remove and shake the motor to see if there are any abnormal noises (disk damage).</li> <li>3. Visually inspect the encoder's rear cover for dust (encoder damage).</li> </ol>	Replace the servo motor.

**When the servo motor is overheating:**

Possible cause	Checking method	Corrective action
Mounting surface of the servo motor has poor thermal conductivity.	Measure the temperatures of the servo motor frame and the mounting surface (metal). The temperature difference should not exceed 20°C (68°F).	Make sure the installation surface is flat; if there are any substance (such as paint, gasket) between the mounting surface and motor surface resulting in poor heat dissipation. Remove the substance or use other methods to help heat dissipation (such as forced air cooling for the servo motor).

### 2.4.2 Mounting directions and precautions for the servo motor

You can install the servo motor horizontally or vertically.

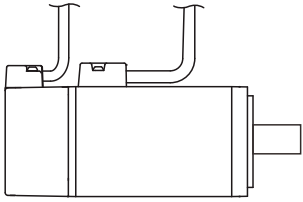
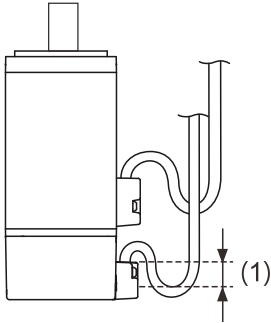
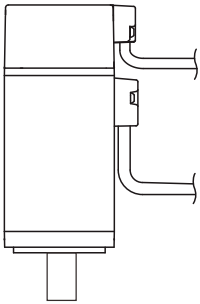
Mounting direction	Precautions
<p style="text-align: center;">Horizontal</p> 	<p>If you are using a servo motor with an oil seal, refer to Section 2.4.5 for oil and water prevention measures for the servo motor.</p>
<p style="text-align: center;">Vertical - shaft end up</p> 	<ul style="list-style-type: none"> <li>■ When wiring, you need to install an oil trap (marked as (1) in the figure on the left) to prevent vapor from entering the motor.</li> <li>■ When installing the servo motor in a machine (such as in a gearbox), you must adhere to the measures in Section 2.4.5 to prevent oil and gas from entering the servo motor.</li> </ul>
<p style="text-align: center;">Vertical - shaft end down</p> 	<p>If you are using a servo motor with an oil seal, refer to Section 2.4.5 for oil and water prevention measures for the servo motor.</p>

Note: if you desire to install gears on the servo motor, follow the manufacturer's instructions for installation.

### 2.4.3 Precautions for using servo motor with oil seal

This section defines the operating conditions for using the servo motor with an oil seal:

1. In the operating environment, keep the oil level lower than the oil seal lip. If the oil seal lip is lower than the oil level, the oil will enter the servo motor and cause damage to the motor.

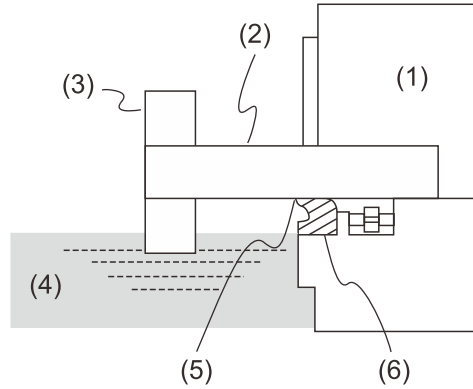

(1) Servo motor; (2) Motor shaft; (3) Gear; (4) Oil; (5) Oil seal lip; (6) Oil seal

2. The oil seal cannot be submerged in the liquid; it can only withstand splashes of oil.
3. The oil seal lip cannot be soaked in oil.

### 2.4.4 Precautions for installing servo motor accessories

- Wipe off the rustproof coating or oil on the motor shaft.
- If you use a servo motor with a keyway, install the attached key or a key matching the specified dimensions on the motor shaft.
- When installing the key or the motor shaft accessories (such as a belt pulley or gear) to the servo motor, do not apply excessive impact force to the keyway. Instead, use a screwdriver and a screw.

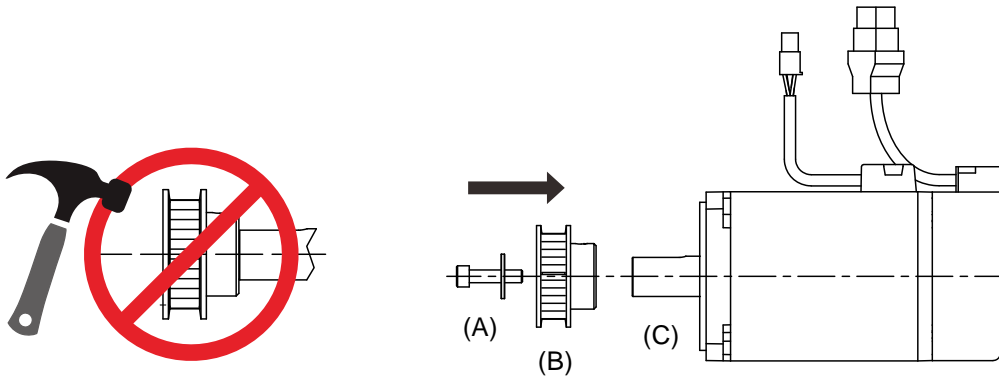

(A) Screw and gasket (B) Belt pulley (C) Servo motor shaft

#### Installation safety precautions for coupling applications

- It is suggested that you use flexible couplings specifically designed for servo motors, especially double spring couplings, which provide some buffer tolerance during eccentric motion and deflection of the motor. Select couplings of appropriate size for the operating conditions. Improper use or connection may cause damage to the motor.
- Use dial gauge or other methods to ensure the centering precision is within the specifications. If you cannot use the dial gauge or other methods, slide the coupling along both axes and adjust it until it does not get stuck.

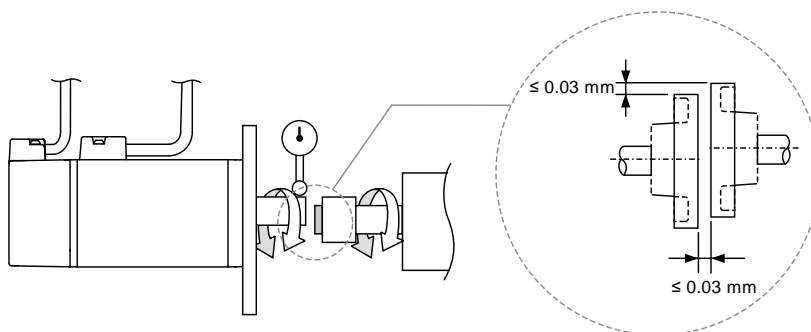

As shown in the previous figure, the distance is measured at four different positions on the circumference for the centering precision. The difference between the maximum and minimum measurements should be 0.03 mm or less. Even within this range, you can make adjustments to increase the centering precision.

**Note:** when you are doing the measurements, rotate the coupling and the motor shaft together.



## 2

**Installation safety precautions for servo motor shaft**

- When connecting the shaft, make sure that the required centering precision is reached. If the shaft is not correctly centered, vibration may damage the bearings and encoder.
- When installing the coupling, do not apply excessive force to the shaft or the area around the encoder, as the impact may damage the encoder.

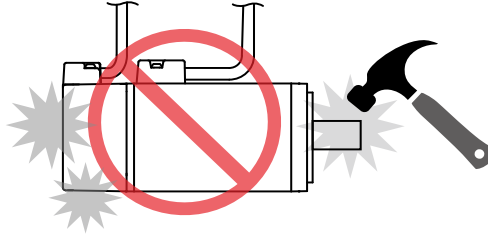

- If the coupling makes any abnormal noise, realign the shaft until the noise disappears.
- Ensure the axial load and radial load are within the specifications. Refer to the specifications for the maximum axial load (N) and maximum radial load (N) for each servo motor.
- Use a bearing puller (D) to remove the motor shaft accessories (such as a coupling, gear or belt pulley). Do not tug or apply excessive force.

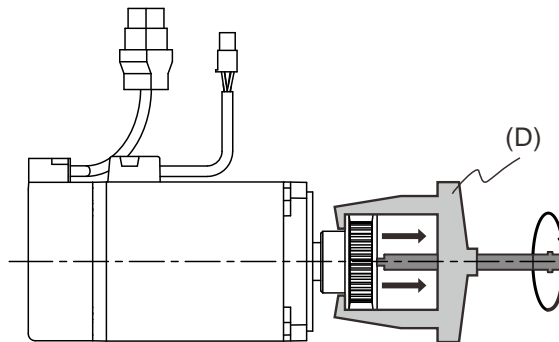

### 2.4.5 Oil and water prevention measures for the servo motor

Follow these precautions and do not allow water, oil, or other foreign objects to enter the servo motor.

- Do not submerge the cable in oil or water.

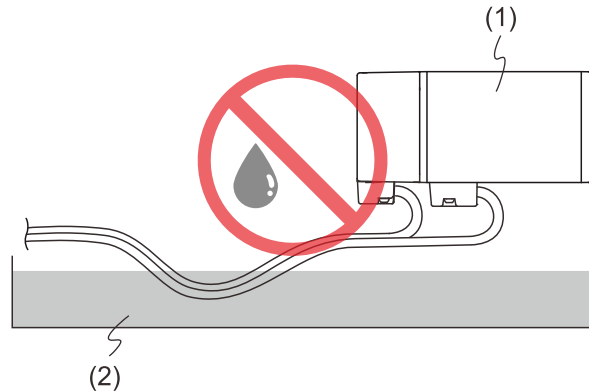

(1) Servo motor; (2) Oil

- If oil or water is unavoidable, use oil-resistant cables. Delta does not provide oil-resistant cables.
- If the servo motor must be mounted with the shaft end up, do not use it in a machine, gearbox, or other environment where the servo motor may have contact with oil or water.

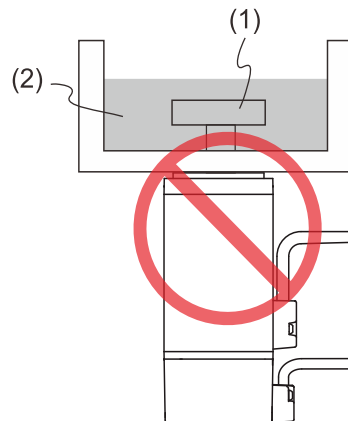

(1) Gear; (2) Oil

- Do not use the servo motor in an environment with cutting fluids. Depending on the type of cutting fluids, sealing materials, coated colloids, cables, or other components may be affected or even deteriorated.
- Do not continuously expose the servo motor to oil mist, water vapor, oil, water, or grease.

If you cannot avoid using the servo motor under the above conditions, take prevention measures to avoid dirt and water from entering the machine.

## 2

**2.4.6 Measures to suppress temperature increase of the servo motor**

- When installing the servo motor, pay attention to the cooling conditions (such as size of the heat sink) provided in the specifications of each servo motor type.
- The heat generated during the motor operation is dissipated to the heat sink through the motor mounting surface. Therefore, if the surface area of the heat sink is too small, the temperature of the servo motor may increase abnormally.
- If it is difficult to apply large heat sinks in the operating environment or if the ambient air temperature or height exceeds the given specifications, take the following measures:

- (1) Reduce the full-load rating of the servo motor: for more details, refer to the specifications of each servo motor type.

When selecting servo motors, consider motors with the power capacity 1 to 2 levels higher.

- (2) Reduce the acceleration and deceleration of the work cycle to lower the motor load.
- (3) Apply external forced air cooling to the servo motor by using cooling fans or other methods.

Important: do not place a gasket or other insulating materials between the servo motor and heat sink, as it may cause motor temperature increase, affect noise immunity, and result in malfunction.

## 2.5 Specifications for the circuit breaker, magnetic contactor and fuse

### 220V models

Control circuit power (L1c, L2c)			
Servo drive model	Circuit breaker	Magnetic contactor (MC)	Fuse (Class T)
ASD-A3-0121-□	1 A	1 A	1 A
ASD-A3-0221-□	1 A	1 A	1 A
ASD-A3-0421-□	1 A	1 A	1 A
ASD-A3-0721-□	3 A	3 A	3 A
ASD-A3-1021-□	3 A	3 A	3 A
ASD-A3-1521-□	3 A	3 A	3 A
ASD-A3-2023-□	3 A	3 A	3 A
ASD-A3-3023-□	3 A	3 A	3 A
ASD-A3-4523-□	5 A	5 A	6 A
ASD-A3-5523-□	5 A	5 A	6 A
ASD-A3-7523-□	5 A	5 A	6 A
ASD-A3-1B23-□	5 A	5 A	6 A
ASD-A3-1F23-□	5 A	5 A	6 A

Main circuit power (RST)			
Servo drive model	Circuit breaker	Magnetic contactor (MC)	Fuse (Class T)
ASD-A3-0121-□	5 A	5 A	5 A
ASD-A3-0221-□	5 A	5 A	5 A
ASD-A3-0421-□	10 A	10 A	10 A
ASD-A3-0721-□	10 A	10 A	20 A
ASD-A3-1021-□	15 A	15 A	25 A
ASD-A3-1521-□	20 A	20 A	35 A
ASD-A3-2023-□	30 A	30 A	50 A
ASD-A3-3023-□	30 A	30 A	70 A
ASD-A3-4523-□	70 A	70 A	100 A
ASD-A3-5523-□	75 A	75 A	150 A
ASD-A3-7523-□	95 A	95 A	150 A
ASD-A3-1B23-□	110 A	110 A	200 A
ASD-A3-1F23-□	120 A	120 A	200 A

#### Note:

1. In the servo drive model name, □ represents the model type.
2. Operation mode: standard.
3. If the servo drive is equipped with a residual-current device (RCD) for electricity leakage protection, select a circuit breaker with sensitivity of at least 200 mA and with minimum 0.1 sec working time to avoid incorrect operation of the RCD.
4. Select the Type B residual-current device (RCD) with time delay, as the system ground wire may contain DC electricity.
5. Use the fuse and circuit breaker that comply with the UL / CSA standard.

6. If authority in the country may designate  $I\Delta n$  and maximum fault loop impedance, you shall follow the rule in such a case.

Servo drive model	Maximum fault loop impedance	
	TN system	TT system
ASD-A3-0121-□	2.3 Ω	139 Ω
ASD-A3-0221-□	1.66 Ω	139 Ω
ASD-A3-0421-□	1.26 Ω	139 Ω
ASD-A3-0721-□	0.85 Ω	139 Ω
ASD-A3-1021-□	0.75 Ω	139 Ω
ASD-A3-1521-□	0.75 Ω	139 Ω
ASD-A3-2023-□	0.75 Ω	139 Ω
ASD-A3-3023-□	0.75 Ω	139 Ω
ASD-A3-4523-□	0.65 Ω	139 Ω
ASD-A3-5523-□	0.65 Ω	139 Ω
ASD-A3-7523-□	0.63 Ω	139 Ω
ASD-A3-1B23-□	0.61 Ω	139 Ω
ASD-A3-1F23-□	0.6 Ω	139 Ω

2

**400V models**

Servo drive model	Circuit breaker	Magnetic contactor (MC)	Fuse (Class T)
ASD-A3-0443-□	10 A	5 A	10 A
ASD-A3-0743-□	15 A	10 A	15 A
ASD-A3-1043-□	15 A	10 A	15 A
ASD-A3-1543-□	20 A	15 A	20 A
ASD-A3-2043-□	25 A	15 A	25 A
ASD-A3-3043-□	30 A	25 A	35 A
ASD-A3-4543-□	50 A	40 A	50 A
ASD-A3-5543-□	50 A	40 A	60 A
ASD-A3-7543-□	60 A	50 A	80 A
ASD-A3-1B43-□	90 A	80 A	100 A
ASD-A3-1F43-□	90 A	80 A	110 A

Note:

1. In the servo drive model name, □ represents the model type.
2. Operation mode: standard.
3. If the servo drive is equipped with a residual-current device (RCD) for electricity leakage protection, select a circuit breaker with sensitivity of at least 200 mA and with minimum 0.1 sec working time to avoid incorrect operation of the RCD.
4. Select the Type B residual-current device (RCD) with time delay, as the system ground wire may contain DC electricity.
5. Use the fuse and circuit breaker that comply with the UL / CSA standard.
6. If authority in the country may designate  $I\Delta n$  and maximum fault loop impedance, you shall follow the rule in such a case.

Servo drive model	Maximum fault loop impedance	
	TN system	TT system
ASD-A3-0443-□	1.6 $\Omega$	220 $\Omega$
ASD-A3-0743-□	1.3 $\Omega$	220 $\Omega$
ASD-A3-1043-□	1.3 $\Omega$	220 $\Omega$
ASD-A3-1543-□	1.01 $\Omega$	220 $\Omega$
ASD-A3-2043-□	0.85 $\Omega$	220 $\Omega$
ASD-A3-3043-□	0.75 $\Omega$	220 $\Omega$
ASD-A3-4543-□	0.69 $\Omega$	220 $\Omega$
ASD-A3-5543-□	0.65 $\Omega$	220 $\Omega$
ASD-A3-7543-□	0.65 $\Omega$	220 $\Omega$
ASD-A3-1B43-□	0.62 $\Omega$	220 $\Omega$
ASD-A3-1F43-□	0.62 $\Omega$	220 $\Omega$

## 2

## 2.6 Ferrite ring

The ferrite ring suppresses high-frequency noise, which can reduce high-frequency interference in the power cable, signal cable, and connectors. The ferrite ring is usually made of Mn-Zn ferrite. The impedance of the ferrite ring varies with frequency. Normally, its impedance is relatively small to low-frequency signals; however, when the frequency of the signal increases, the impedance increases dramatically, which optimizes signal transmission. Suggested ferrite ring models:

Ferrite ring model	Applicable servo drive model
ASD-ACFC7K00	ASD-A3-4523-□, ASD-A3-5523-□, ASD-A3-7523-□, ASD-A3-1B23-□, ASD-A3-1F23-□
	ASD-A3-2043-□, ASD-A3-3043-□, ASD-A3-4543-□, ASD-A3-5543-□, ASD-A3-7543-□, ASD-A3-1B43-□, ASD-A3-1F43-□

Note: in the servo drive model column, □ represents the model code.

### Installation precautions

The ferrite ring is commonly used when peripheral devices (such as the controller) are affected by noise from conduction and radiation when the servo motor is in the Servo On state.

The parasitic capacitance between the cables in the wiring panel and the ground is typically small, but as the frequency of the signal increases (Servo On state), the resistance of the parasitic capacitance becomes small enough for the common-mode current to flow through.

Normally, common-mode current only leads to common-mode interference due to an unstable circuit caused by a poor connection between the power circuit and ground. If the common-mode current flows through the external cables, common-mode interference may also happen due to electrical interference caused by unstable electric potential.

The ferrite ring causes eddy current losses to high-frequency signals and transforms them into heat when suppressing common-mode interference. The ferrite ring acts as a low-pass filter to effectively suppress high-frequency noise and ensure the stability of the circuit while the impedance to low-frequency signals is relatively small.

Winding several turns of wire onto the ferrite ring can increase inductance and the ability to filter out high-frequency noise. The suggested winding methods are shown as follows:

1. For 4.5 kW to 7.5 kW models

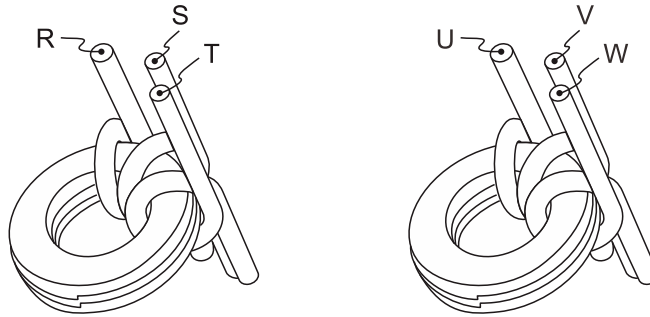

2. For 11 kW to 15 kW models

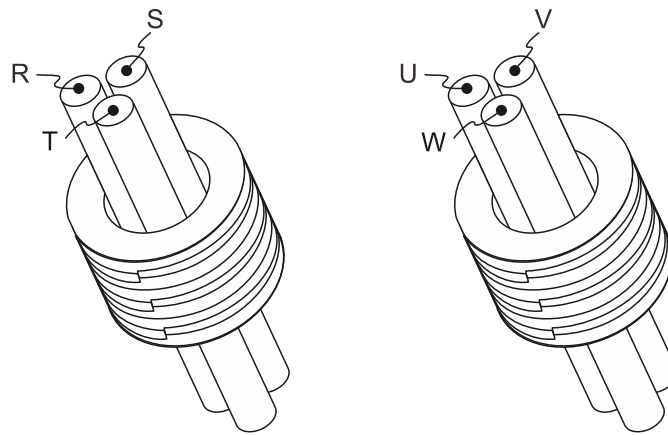

Note:

1. Refer to Section 3.1.6.5 for the selection of the motor power cable.
2. Only the motor power cable or power cable can run through the ferrite ring. If needed, prepare extra ferrite rings for grounding.
3. An EMI filter for absorbing radiation may be required when using a longer motor power cable.



# 2

## 2.7 Installation requirements for EMC

This section illustrates the installation requirements for passing the EMC test. Note that the EMC rating varies based on the installation structure or wiring. Delta servo products are designed in accordance with the specifications of the EMC test. Refer to the following diagram for the standard installation. The following diagram illustrates the standard installation method for Delta servo products to pass the EMC test.

### 220V Models

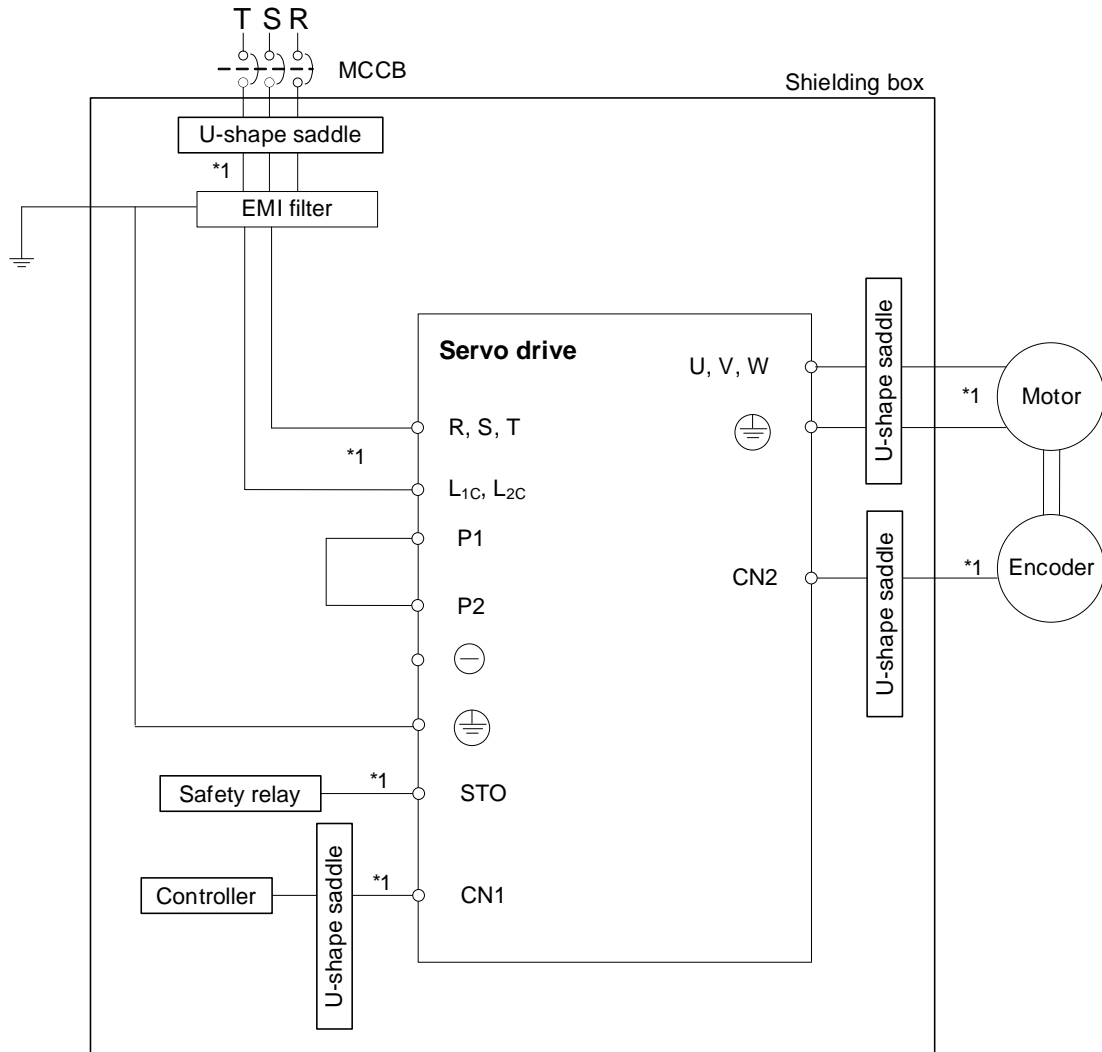

Note:

\*1. Use shielded wires.

400V Models

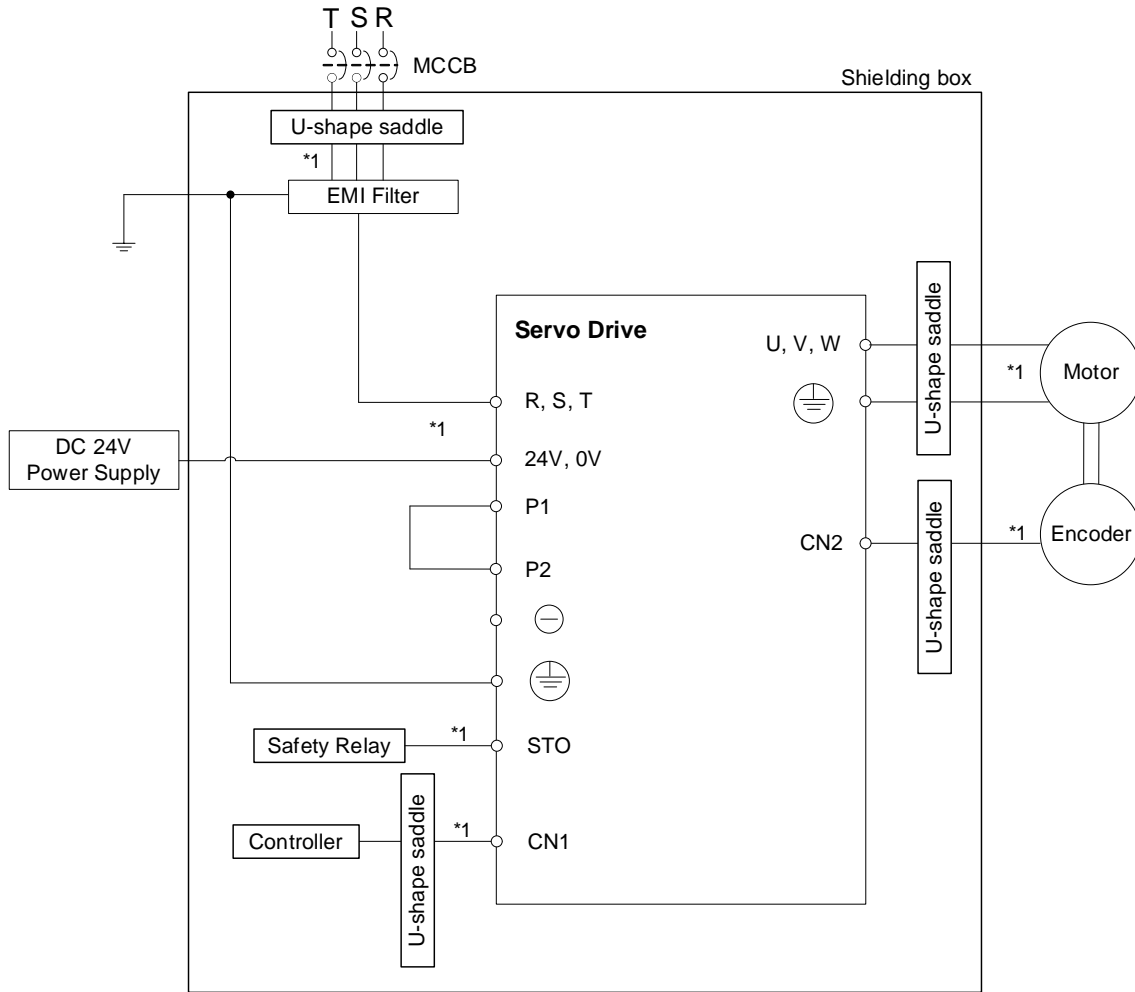

2

Note:

\*1. Use shielded wires.

## 2

### 2.7.1 EMI filters

All electronic equipment (including servo drives) generate high or low frequency noise during operation, which interferes with peripheral equipment through conduction or radiation. With an EMI filter correctly installed and used, you can eliminate much of the interference. For optimized performance, it is recommended to use Delta's EMI filter for suppressing the interference.

#### 220V Models

Power	Servo drive model	Recommended EMI filter	
		1PH	3PH
100 W	ASD-A3-0121-□	EMF023A21A	EMF10AM23A
200 W	ASD-A3-0221-□	EMF023A21A	EMF10AM23A
400 W	ASD-A3-0421-□	EMF023A21A	EMF10AM23A
750 W	ASD-A3-0721-□	EMF023A21A	EMF10AM23A
1 kW	ASD-A3-1021-□	EMF023A21A	EMF10AM23A
1.5 kW	ASD-A3-1521-□	EMF023A21A	EMF24AM23B
2 kW	ASD-A3-2023-□	-	EMF24AM23B
3 kW	ASD-A3-3023-□	-	EMF24AM23B
4.5 kW	ASD-A3-4523-□	-	EMF035A23A
5.5 kW	ASD-A3-5523-□	-	EMF035A23A
7.5 kW	ASD-A3-7523-□	-	EMF035A23A
11 kW	ASD-A3-1B23-□	-	EMF056A23A
15 kW	ASD-A3-1F23-□	-	B84143D0075R127

#### 400V Models

Power	Servo drive model	Recommended EMI filter
		3PH
400 W	ASD-A3-0443-□	EMF014A43A
750 W	ASD-A3-0743-□	EMF014A43A
1 kW	ASD-A3-1043-□	EMF014A43A
1.5 kW	ASD-A3-1543-□	EMF014A43A
2 kW	ASD-A3-2043-□	EMF018A43A
3 kW	ASD-A3-3043-□	EMF018A43A
4.5 kW	ASD-A3-4543-□	EMF033A43A
5.5 kW	ASD-A3-5543-□	EMF033A43A
7.5 kW	ASD-A3-7543-□	EMF033A43A
11 kW	ASD-A3-1B43-□	B84143D0075R127
15 kW	ASD-A3-1F43-□	B84143D0075R127

Note: in the servo drive model column, □ represents the model code.

### General precautions for installation

To ensure the best performance of the EMI filter, apart from the instruction and wiring of the servo drive, refer to these precautions:

1. The servo drive and EMI filter must be mounted on the same metal plate.
2. The wiring should be as short as possible.
3. The metal plate should be well grounded.
4. It is recommended to install one servo drive with one EMI filter.

More specifications for mounting the servo drive are listed as follows:

1. EN61000-6-4 (2001)
2. EN61800-3 (2004) PDS of category C2
3. EN55011+A2 (2007) Class A Group 1

### Motor cable selection and installation precautions

The selection of motor cable (refer to Chapter 3 Wiring) and installation accuracy determine the performance of the EMI filter. Follow these precautions:

1. Use a cable that has braided shielding (the effect of double shielding is better).
2. The shield on both ends of the motor cable should be grounded with the shortest cable length and the largest contact area.
3. Remove the protective paint on the U-shape saddle and metal plate to ensure good contact. See the following figure.
4. Correctly connect the braided shielding of the motor cable and the metal plate: fix the braided shielding on both ends of the motor cable with the U-shape saddle and metal plate. See the following figure.

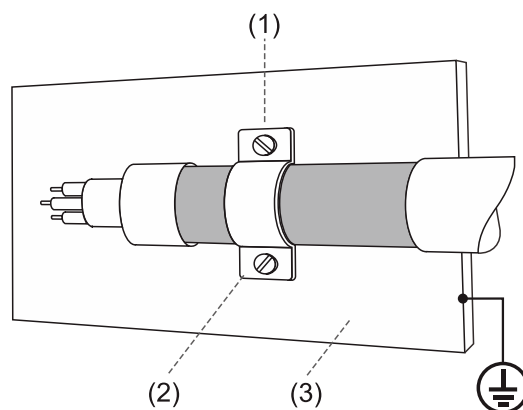

- (1) Remove the protective paint on the U-shape saddle and metal plate to ensure good contact.
- (2) U-shape saddle
- (3) Well-grounded metal plate

# 2

## 2.8 Selecting the regenerative resistor

Some of our servo drive models has a built-in regenerative resistor, you can use an external regenerative resistor if needed. When the direction of torque is opposite to the direction of rotation, the energy generated returns to the servo drive from the load. This energy is turned into electricity in the capacitance of the DC Bus and thus increases the voltage. When the voltage reaches a given value, the excess energy is consumed by a regenerative resistor. Refer to the following table to select the suitable regenerative resistor.

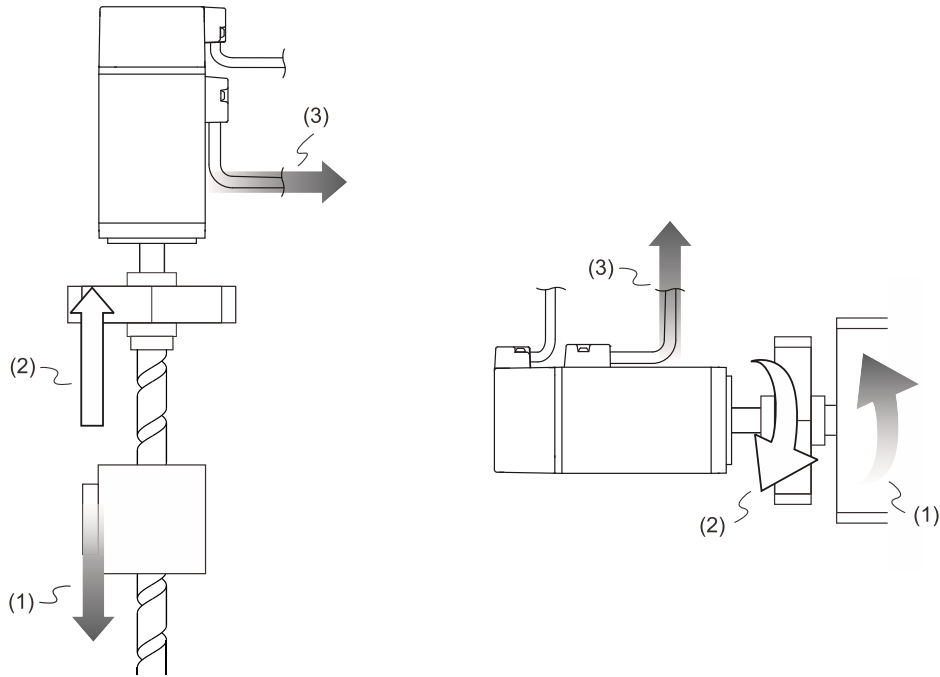

(1) Moving direction of the object; (2) Direction of torque; (3) Regenerative energy

Specifications of the built-in regenerative resistor in the ASDA-A3 are as follows:

### 220V Models

Servo drive (kW)	Specifications of the built-in regenerative resistor		Capacity of the built-in regenerative resistor (Watt)	Minimum allowable resistance value (reference for external resistors) (Ohm)
	Resistance (Ohm)	Capacity (Watt)		
0.1	-	-	-	60
0.2	-	-	-	60
0.4	100	40	20	60
0.75	100	40	20	60
1.0	100	40	20	30
1.5	100	40	20	30
2.0	20	80	40	15
3.0	20	80	40	15
4.5	20	100	30	10
5.5	-	-	-	8
7.5	-	-	-	8
11	-	-	-	6
15	-	-	-	5

### 400V Models

Servo drive (kW)	Specifications of the built-in regenerative resistor		Capacity of the built-in regenerative resistor (Watt)	Minimum allowable resistance value (reference for external resistors) (Ohm)
	Resistance (Ohm)	Capacity (Watt)		
0.4	80	60	30	80
0.75	80	60	30	60
1	80	60	30	60
1.5	80	60	30	40
2	-	-	-	40
3	-	-	-	30
4.5	-	-	-	25
5.5	-	-	-	25
7.5	-	-	-	15
11	-	-	-	15
15	-	-	-	15

# 2

When the regenerative energy exceeds the capacity of the built-in regenerative resistor, use an external regenerative resistor. Pay special attention to the following when using a regenerative resistor:

1. Choose the correct resistance value (P1.052) and capacity (P1.053) settings for the regenerative resistor; otherwise it might affect the performance.
2. When using an external regenerative resistor, ensure the total resistance value is greater than the minimum allowable resistance value of the servo drive.
3. For general applications, you can connect more than one resistor in series. If the resistance value (from resistors connected in series) exceeds the rated range, you can reduce the value by connecting the resistors in parallel. If you want to connect the resistors in parallel to increase the power of the regenerative resistors, make sure the resistance value meets the requirements.

See the following diagrams and settings for connecting the regenerative resistors in series and in parallel.

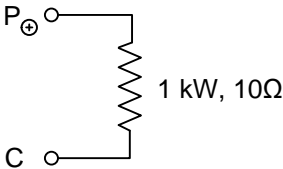
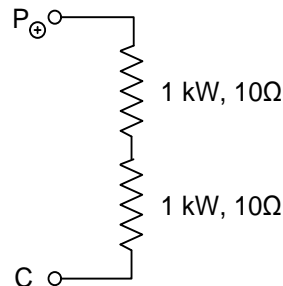
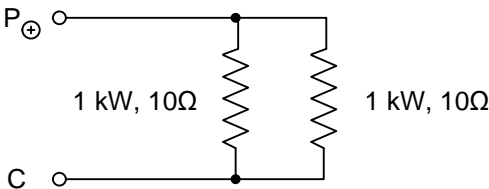
Connect to one external regenerative resistor	
	P1.052 = 10 (Ω) P1.053 = 1000 (W)
Connect to external regenerative resistors (serial connection)	
	P1.052 = 20 (Ω) P1.053 = 2000 (W)
Connect to external regenerative resistors (parallel connection)	
	P1.052 = 5 (Ω) P1.053 = 2000 (W)

4. Normally, if the capacity of the regenerative resistor (the average value) is within the rated capacity, the temperature of the resistor can increase to 120°C (248°F) or even higher under the condition that the regenerative energy continues to function. For safety reasons, apply forced cooling to reduce the temperature of the regenerative resistor. Alternatively, you can use regenerative resistors equipped with thermal switches. Contact the manufacturer for the load characteristics of the regenerative resistor.

When installing an external regenerative resistor, connect the resistor to P3 and C contacts, and P3 and D contacts are left open. It is recommended that you choose external regenerative resistors of the resistance values specified in the table on the previous page. For easy calculation of the required regenerative resistor capacity, regardless of the energy consumed by IGBT, select the capacity of the external regenerative resistor according to the selected rotary motor.

**Rotary motor:**

Selecting the regenerative energy

- (a) Calculation of the regenerative energy when there is no external torque.

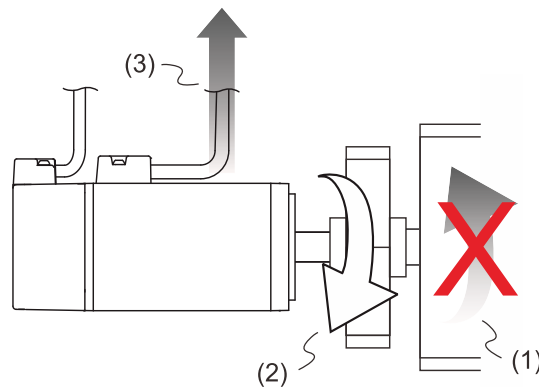

(1) Moving direction of the object; (2) Direction of torque;  
 (3) Regenerative energy generated when the motor decelerates

If the motor is making a reciprocating motion, the regenerative resistor consumes the excess return energy. Refer to the following table when calculating and selecting the required regenerative resistor.

**220V Models**

Inertia	Servo drive (kW)	Motor	Rotor inertia ( $\times 10^{-4}\text{kg}\cdot\text{m}^2$ )	Regenerative energy generated when the motor decelerates from 3000 rpm to 0 without load $E_o$ (joule)	Maximum regenerative energy of the capacitance $E_c$ (joule)
Low inertia	0.1	ECM-A3L-C2040F345	0.0229	0.11	4.21
	0.1	ECM-A3L-C20401345	0.04	0.20	4.21
	0.2	ECM-A3L-C20602345	0.09	0.45	8.42
	0.4	ECM-A3L-C20604345	0.15	0.74	8.42
	0.4	ECM-A3L-C20804345	0.352	1.74	8.42
	0.75	ECM-A3L-C20807345	0.559	2.76	17.47
Medium inertia	0.1	ECM-B3L-C20401345	0.0299	0.15	4.21
	0.2	ECM-B3M-C20602345	0.141	0.70	8.42
	0.4	ECM-B3M-C20604345	0.254	1.26	8.42
	0.4	ECM-B3M-C20804345	0.648	3.20	8.42
	0.75	ECM-B3M-C20807345	1.070	5.29	17.47



2

Inertia	Servo drive (kW)	Motor	Rotor inertia ( $\times 10^{-4}\text{kg}\cdot\text{m}^2$ )	Regenerative energy generated when the motor decelerates from 3000 rpm to 0 without load $E_o$ (joule)	Maximum regenerative energy of the capacitance $E_c$ (joule)
Medium inertia	1.0	ECM-B3M-C <sup>2</sup> 0810 <sup>3</sup> 4 <sup>5</sup>	1.37	6.77	26.21
	1.0	ECM-B3M-C <sup>2</sup> 1010 <sup>3</sup> 4 <sup>5</sup>	2.78	13.75	26.21
	1.5	ECM-B3M-C <sup>2</sup> 1015 <sup>3</sup> 4 <sup>5</sup>	3.69	18.25	26.21
	2.0	ECM-B3M-C <sup>2</sup> 1020 <sup>3</sup> 4 <sup>5</sup>	4.68	23.14	29.33
	1.0	ECM-B3M-E <sup>2</sup> 1310 <sup>3</sup> 4 <sup>5</sup>	7.790	17.12	26.21
	1.5	ECM-B3M-E <sup>2</sup> 1315 <sup>3</sup> 4 <sup>5</sup>	11.220	24.66	26.21
	2.0	ECM-B3M-E <sup>2</sup> 1320 <sup>3</sup> 4 <sup>5</sup>	14.650	32.20	29.33
	2.0	ECM-B3M-E <sup>2</sup> 1820 <sup>3</sup> 4 <sup>5</sup>	29.110	63.98	29.33
	3.0	ECM-B3M-F <sup>2</sup> 1830 <sup>3</sup> 4 <sup>5</sup>	53.630	66.30	34.94
	1.0	ECMC-C <sup>2</sup> 1010 <sup>3</sup> 4	2.65	13.1	26.21
	1.0	ECMC-E <sup>2</sup> 1310 <sup>3</sup> 4	8.41	18.48	26.21
	1.5	ECMC-E <sup>2</sup> 1315 <sup>3</sup> 4	11.2	24.62	26.21
	2.0	ECMC-E <sup>2</sup> 1320 <sup>3</sup> 4	14.6	32.09	29.33
	2.0	ECMC-E <sup>2</sup> 1820 <sup>3</sup> 4	34.7	76.26	29.33
	3.0	ECMC-E <sup>2</sup> 1830 <sup>3</sup> 4	55	120.88	34.94
	3.0	ECMC-F <sup>2</sup> 1830 <sup>3</sup> 4	55	67.99	34.94
High inertia	0.1	ECM-A3H-C <sup>2</sup> 040F <sup>3</sup> 4 <sup>5</sup>	0.0455	0.23	4.21
	0.1	ECM-A3H-C <sup>2</sup> 0401 <sup>3</sup> 4 <sup>5</sup>	0.0754	0.37	4.21
	0.2	ECM-A3H-C <sup>2</sup> 0602 <sup>3</sup> 4 <sup>5</sup>	0.25	1.24	8.42
	0.4	ECM-A3H-C <sup>2</sup> 0604 <sup>3</sup> 4 <sup>5</sup>	0.45	2.23	8.42
	0.4	ECM-A3H-C <sup>2</sup> 0804 <sup>3</sup> 4 <sup>5</sup>	0.92	4.55	8.42
	0.75	ECM-A3H-C <sup>2</sup> 0807 <sup>3</sup> 4 <sup>5</sup>	1.51	7.47	17.47
	1.0	ECMC-F <sup>2</sup> 1308 <sup>3</sup> 4	13.6	16.81	26.21
	2.0	ECMC-F <sup>2</sup> 1313 <sup>3</sup> 4	20	24.73	26.21
	2.0	ECMC-F <sup>2</sup> 1318 <sup>3</sup> 4	24.9	30.78	29.33
	1.5	ECM-B3H-F <sup>2</sup> 1308 <sup>3</sup> 4 <sup>5</sup>	12.44	15.38	26.21
	2.0	ECM-B3H-F <sup>2</sup> 1313 <sup>3</sup> 4 <sup>5</sup>	18	22.25	34.94
	2.0	ECM-B3H-F <sup>2</sup> 1318 <sup>3</sup> 4 <sup>5</sup>	22.6	27.94	29.33
Medium inertia	4.5	ECM-B3M-F <sup>2</sup> 1845 <sup>3</sup> 4 <sup>5</sup>	67.73	83.73	42.43
	5.5	ECM-B3M-F <sup>2</sup> 1855 <sup>3</sup> 4 <sup>5</sup>	98.88	122.24	51.17
	7.5	ECM-B3M-F <sup>2</sup> 1875 <sup>3</sup> 4 <sup>5</sup>	134.95	166.83	76.75
	11	ECM-B3M-F <sup>2</sup> 221B <sup>3</sup> 4 <sup>5</sup>	302.2	373.60	109.20
	15	ECM-B3M-F <sup>2</sup> 221F <sup>3</sup> 4 <sup>5</sup>	400	494.51	171.60

Note: in the motor column, <sup>2</sup> represents the encoder type, <sup>3</sup> represents the brake or keyway / oil seal type, <sup>4</sup> represents the shaft diameter, and <sup>5</sup> represents the special code.

## 400V Models

Inertia	Servo drive (kW)	Motor	Rotor inertia ( $\times 10^{-4}\text{kg}\cdot\text{m}^2$ )	Regenerative energy generated when the motor decelerates from 3000 rpm to 0 without load $E_0$ (joule)	Maximum regenerative energy of the capacitance $E_c$ (joule)
Medium inertia	0.4	ECM-B3M-J <sup>2</sup> 0604 <sup>3</sup> <sup>4</sup> <sup>5</sup>	0.254	1.26	8.42
	0.75	ECM-B3M-J <sup>2</sup> 0807 <sup>3</sup> <sup>4</sup> <sup>5</sup>	1.07	5.29	10.30
	1.0	ECM-B3M-J <sup>2</sup> 1010 <sup>3</sup> <sup>4</sup> <sup>5</sup>	2.78	13.75	12.17
	1.5	ECM-B3M-J <sup>2</sup> 1015 <sup>3</sup> <sup>4</sup> <sup>5</sup>	3.69	18.25	14.66
	2.0	ECM-B3M-J <sup>2</sup> 1020 <sup>3</sup> <sup>4</sup> <sup>5</sup>	4.68	23.14	24.34
	1.0	ECM-B3M-K <sup>2</sup> 1310 <sup>3</sup> <sup>4</sup> <sup>5</sup>	7.79	17.12	12.17
	1.5	ECM-B3M-K <sup>2</sup> 1315 <sup>3</sup> <sup>4</sup> <sup>5</sup>	11.22	24.66	14.66
	2.0	ECM-B3M-K <sup>2</sup> 1320 <sup>3</sup> <sup>4</sup> <sup>5</sup>	14.65	32.20	24.34
High inertia	1.0	ECM-B3H-L <sup>2</sup> 1308 <sup>3</sup> <sup>4</sup> <sup>5</sup>	12.44	15.38	12.17
	1.5	ECM-B3H-L <sup>2</sup> 1313 <sup>3</sup> <sup>4</sup> <sup>5</sup>	18	22.25	14.66
	2.0	ECM-B3H-L <sup>2</sup> 1318 <sup>3</sup> <sup>4</sup> <sup>5</sup>	22.6	27.94	24.34
Medium inertia	2.0	ECM-B3M-K <sup>2</sup> 1820 <sup>3</sup> <sup>4</sup> <sup>5</sup>	41.9	92.09	24.34
	3.0	ECM-B3M-L <sup>2</sup> 1830 <sup>3</sup> <sup>4</sup> <sup>5</sup>	53.63	66.3	29.33
	4.5	ECM-B3M-L <sup>2</sup> 1845 <sup>3</sup> <sup>4</sup> <sup>5</sup>	67.73	83.73	42.43
	5.5	ECM-B3M-L <sup>2</sup> 1855 <sup>3</sup> <sup>4</sup> <sup>5</sup>	98.88	122.24	51.17
	7.5	ECM-B3M-L <sup>2</sup> 1875 <sup>3</sup> <sup>4</sup> <sup>5</sup>	134.95	166.83	63.65
	11	ECM-B3M-L <sup>2</sup> 221B <sup>3</sup> <sup>4</sup> <sup>5</sup>	302	373.35	76.75
	15	ECM-B3M-L <sup>2</sup> 221F <sup>3</sup> <sup>4</sup> <sup>5</sup>	400	494.51	102.34

Note: in the motor column, <sup>2</sup> represents the encoder type, <sup>3</sup> represents the brake or keyway / oil seal type, <sup>4</sup> represents the shaft diameter, and <sup>5</sup> represents the special code.

2

Assume that the load inertia is N times the motor inertia, when the motor decelerates from 3,000 rpm to 0, the regenerative energy is  $(N+1) \times E_0$  and the regenerative resistor needs to consume  $(N+1) \times E_0 - E_c$  joules. Assume that the reciprocating motion cycle is T sec, then the required power of regenerative resistor =  $2 \times ((N+1) \times E_0 - E_c) / T$ . The calculation is as follows:

Step	Item	Calculation and setting method
1	Set the capacity of the regenerative resistor to the maximum.	Set P1.053 to the maximum value.
2	Set the operation cycle (T).	Manual input.
3	Set the rotation speed (wr).	Manual input or read the status with P0.002.
4	Set the load / motor inertia ratio (N).	Manual input or read the status with P0.002.
5	Calculate the maximum regenerative energy (Eo).	$E_0 = J \times \omega^2 / 182$
6	Find the regenerative energy that can be absorbed by the capacitor (Ec).	Refer to the preceding table.
7	Calculate the required capacity of the regenerative resistor.	$2 \times ((N+1) \times E_0 - E_c) / T$

Example:

For the motor ECM-A3L-CY0604RS1 (400 W), the reciprocating motion cycle is T = 0.4 sec. Its maximum rotation speed is 3000 rpm and the load inertia is 15 times of the motor inertia.

Servo drive (kW)	Motor	Rotor inertia J ( $\times 10^{-4}$ kg.m <sup>2</sup> )	Regenerative energy generated when the motor decelerates from 3000 rpm to 0 without load Eo (joule)	Maximum regenerative energy of the capacitance Ec (joule)
0.4	ECM-A3L-CY0604RS1	0.15	0.74	8.42

Find the maximum regenerative energy: Eo = 0.74 joules (from the preceding table).

Find the regenerative energy that can be absorbed by the capacitor: Ec = 8.42 joules (from the preceding table).

The required capacity of the regenerative resistor =  $\frac{2 \times ((N + 1) \times E_0 - E_c)}{T} = \frac{2 \times ((15 + 1) \times 0.74 - 8.42)}{0.4} = 17.1 \text{ W}$

From the calculation above, the required power of the regenerative resistor is 17.1 W, which is smaller than the specified capacity. In this case, the built-in 40 W regenerative resistor fulfills the need. In general, the built-in regenerative resistor can meet the requirement when the external load is not too great.

- (b) Calculation of the regenerative energy when there is external torque and the motor does the negative work.

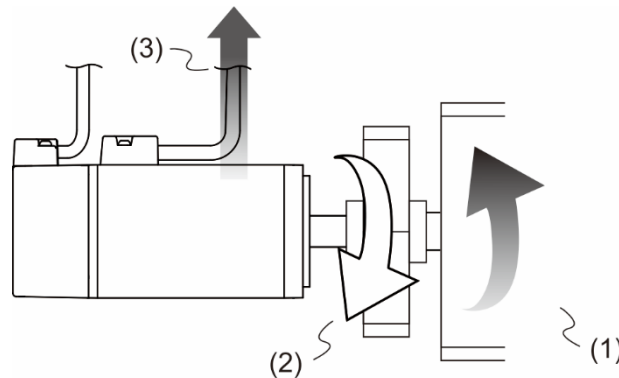

(1) Moving direction of the object; (2) Direction of torque; (3) Regenerative energy

Usually, when the motor does positive work, the motor's torque direction is identical to the rotation direction. However, in some instances, the motor's torque direction is opposite to the rotation direction. This is when the motor is doing negative work and the external energy is applied to the servo drive through the motor. For instance, if the external force direction is identical to the rotation direction (such as downward motion of the vertically-mounted machine), the servo system outputs more power to counterbalance the excessive external force (the weight of vertically-mounted machine) in order to keep up with the specified target speed. In this case, considerable energy returns to the servo drive. When the DC Bus is full and cannot store more energy, this energy is absorbed by the regenerative resistor.

Example:

For a 400 W motor (ECM-A3L-CY0604RS1), when the torque of the external load is +70% of the rated torque (1.27 N-m) with rotation speed up to 3,000 rpm, the required external regenerative resistor is:

$2 \times (0.7 \times 1.27) \times \left( \frac{3000 \times 2 \times \pi}{60} \right) = 558 \text{ W}$ . Therefore, a regenerative resistor of 560 W and 60  $\Omega$  is needed.

2

### 2.9 The use of braking

A brake is usually used for motions in the Z-axis direction because gravity causes the mechanism to fall. A brake can prevent the mechanism from falling and reduce the motor's excessive resistance. The motor lifespan could be reduced due to the excessive heat generated by continuous resistance. To avoid incorrect operation, the brake can be enabled only when the servo is switched off. The drive controls the brake with DO. If DO.BRKR is set to off, it means the brake is not operating and the motor is clamped; if DO.BRKR is set to on, it means the brake is operating and the motor can run freely. You can use MBT1 (P1.042) and MBT2 (P1.043) to set the delay time.

Timing diagram of brake control:

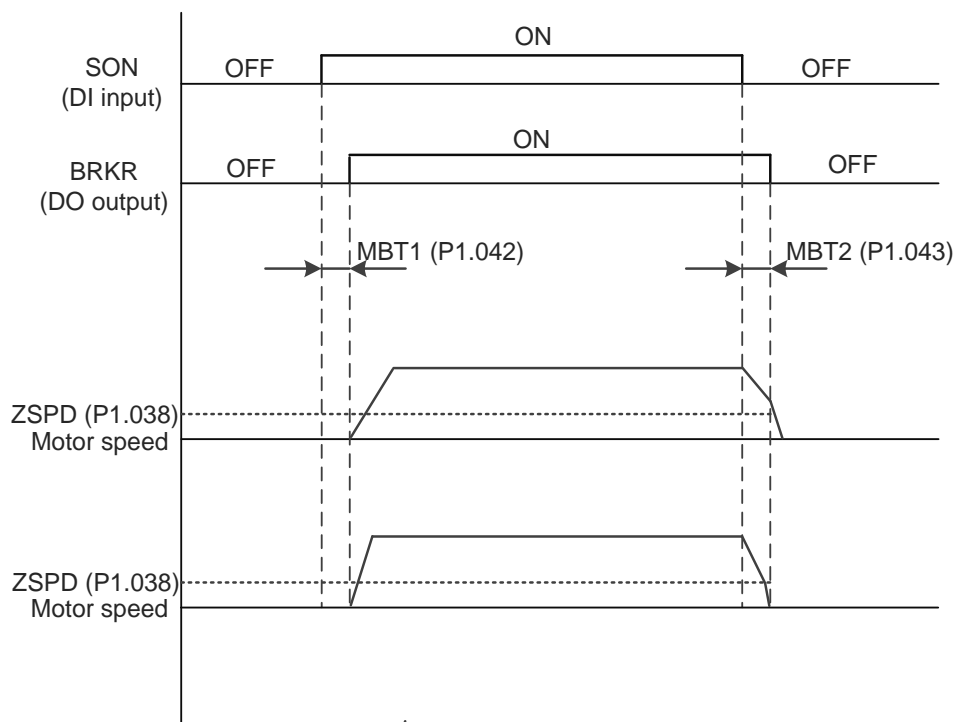

Output timing of the BRKR signal:

1. When the servo drive is off and the time set for P1.043 is exceeded, but the motor speed is still higher than the speed set for P1.038, DO.BRKR is off (the motor is clamped).
2. When the servo drive is off and the time set for P1.043 is not yet reached, but the motor speed is already lower than the speed set for P1.038, DO.BRKR is off (the motor is clamped).

When the motor runs normally (Servo On), DO.BRKR should be set to On, it means the brake is operating and the motor can run freely. Use the emergency stop button in an emergency. Press the button to switch the motor to Off and set DI.EMGS (0x21) to On. Then AL013 is triggered, and the motor is immediately stopped.

Wiring of the brake:

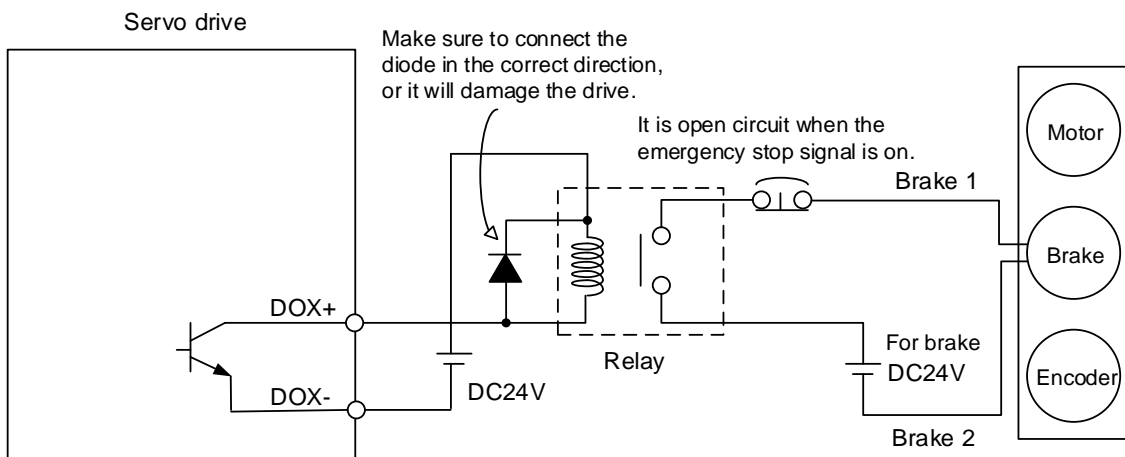

Note:

1. Refer to Chapter 3 Wiring.
2. The brake signal controls the solenoid valve, providing power to the brake and enabling the brake.
3. There is no polarity for the brake coil.

Timing diagram of control power and main power:

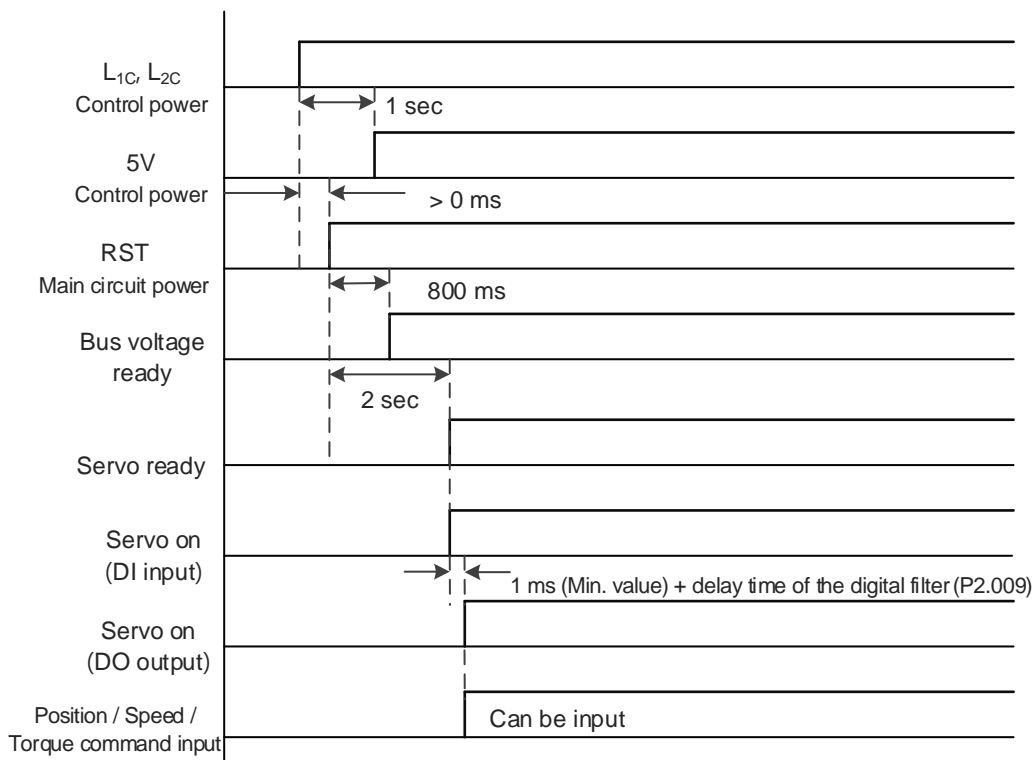

Calculate the brake's rated current (ECM-A3L-CY0604RS1 is used as an example here).

Power consumption of the brake (20°C) = 6.5 W (refer to Appendix A Specifications), so the

$$\text{brake's rated current} = \frac{6.5 \text{ W}}{24 \text{ V}} = 0.27 \text{ A.}$$

2

## 2.10 The use of cable

### Precautions:

- Prevent the junction of the cable and connector from being subject to weight (including that of the attachments) or bending stress.
- If bending the cable is required, start bending it at least 20 mm (0.79 inches) from the junction of the cable and connector. The suggested bend radius is no less than 10 times of the cable outer diameter.
- Avoid scraping, crushing, or stepping on the cable. This can damage the inner wires even when the cable seems intact on the outside.
- Inappropriate installation and wrong usage shorten the cable lifetime.
- Do not twist the cable when installing.

### Standard cable:

- Do not use the standard cable when the cable is required for moving or bending. Please use a flexible cable instead.

### Flexible cable:

- Do not fix the cable on or near the bending part, otherwise the cable may break.
- After cable fixation, make sure the cable can be moved with ease, so that it does not create excessive tension on the bending or fixation part.
- Prevent the connectors of the cable from being subject to stress.
- Excessive cable length causes unnecessary bending, while insufficient cable length leads to breakage due to the excessive tension on the cable fixation part. Estimate the suitable cable length by dragging the cable carrier to the longest and shortest possible.

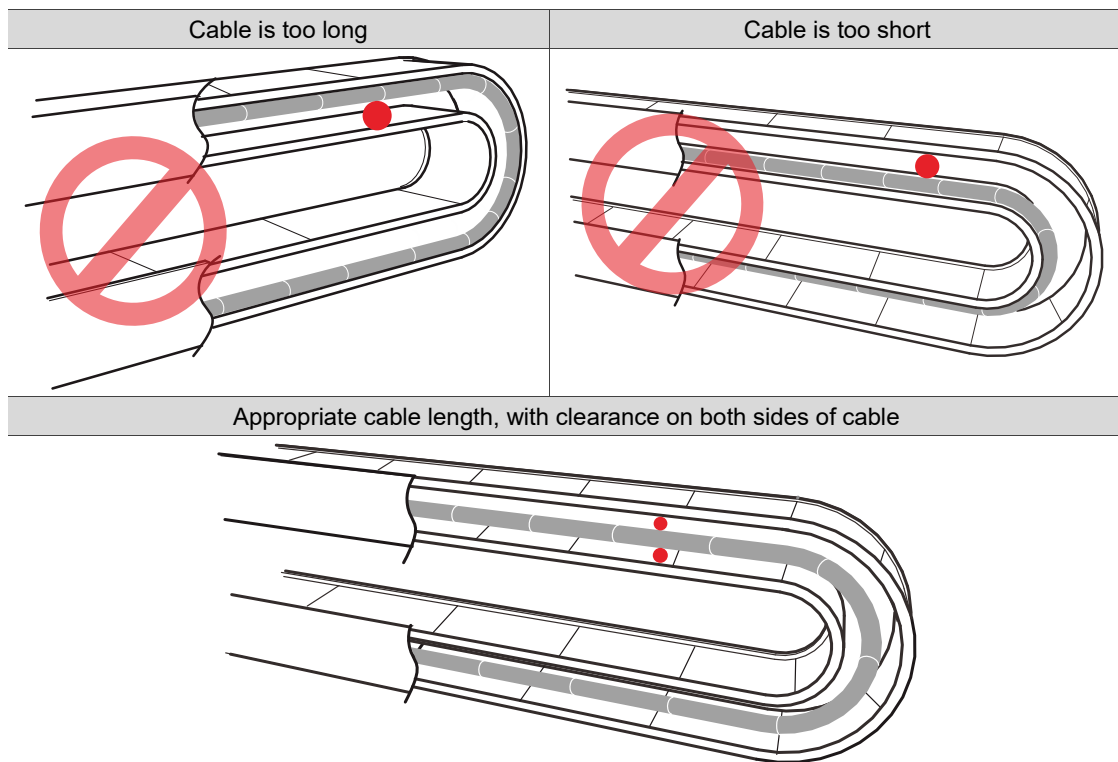

- When installing the cable carrier, avoid contact between the cables. Do not stack the cables one above the other; use dividers to prevent cable entanglement instead.
- Do not bend the flexible cable under any normal circumstances. Refer to Section 3.1.6.6 for detailed flexible cable specifications.



(This page is intentionally left blank.)

2

This chapter illustrates the power supply circuit, connectors, and wiring for each mode of the ASDA-A3 220V and 400V series models. Refer to the detailed descriptions according to the model series.

3.1	220V series servo system connection .....	3-4
3.1.1	Connecting to peripheral devices (connecting to Delta communication type servo motor).....	3-4
3.1.2	Connectors and terminals .....	3-6
3.1.3	Wiring for power supply.....	3-8
3.1.4	UVW power connector specifications .....	3-11
3.1.4.1	F40 - F80 motors – Power connectors .....	3-12
3.1.4.2	F100 - F130 motors – Power connectors .....	3-15
3.1.4.3	F180 4.5 kW (or below) motors – Power connectors .....	3-18
3.1.4.4	F180 5.5 kW (or above) & F220 motors – Power connectors .....	3-21
3.1.5	Encoder cable and connector specifications .....	3-23
3.1.5.1	F40 - F80 motors – Encoder connectors.....	3-23
3.1.5.2	F100 - F180 ECMC motors – Encoder connectors.....	3-30
3.1.5.3	F100 - F220 ECM-B3 motors – Encoder connectors .....	3-33
3.1.6	Wire selection .....	3-39
3.1.6.1	Wire diameters and terminals / ferrules .....	3-39
3.1.6.2	Crimping the wire ferrules .....	3-40
3.1.6.3	Screw terminal block dimensions / screw and tightening torque specifications .....	3-42
3.1.6.4	Encoder cable specifications .....	3-43
3.1.6.5	Power cable specifications .....	3-44
	Motor frame: F40 - F80.....	3-44
	Motor frame: F100 - F130 .....	3-45
	Motor frame and power: F180 4.5 kW (or below) .....	3-46
	Motor frame and power: F180 5.5 kW (or above) & F220 .....	3-47
3.1.6.6	Flexible cable specifications .....	3-48
3.1.7	Waterproof connector wiring instructions .....	3-49
3.1.7.1	F40 - F80 models – power / encoder / brake connector .....	3-49
	CHOGORI connector .....	3-49
	Bulkhead connector .....	3-50
3.1.7.2	F100 - F180 models (4.5 kW or below) – power connector .....	3-52

3.1.7.3	Waterproof connector specifications .....	3-53
3.2	400V series servo system connection .....	3-54
3.2.1	Connecting to peripheral devices (connecting to Delta communication type servo motor).....	3-54
3.2.2	Connectors and terminals .....	3-56
3.2.3	Wiring for power supply.....	3-58
3.2.4	UVW power connector specifications .....	3-59
3.2.4.1	F40 - F80 motors – Power connectors .....	3-59
3.2.4.2	F100 - F130 motors – Power connectors .....	3-59
3.2.4.3	F180 4.5 kW (or below) motors – Power connectors .....	3-59
3.2.4.4	F180 5.5 kW (or above) & F220 motors – Power connectors .....	3-59
3.2.5	Encoder cable and connector specifications .....	3-60
3.2.5.1	F40 - F80 motors – Encoder connectors.....	3-60
3.2.5.2	F100 - F220 ECM-B3 motors – Encoder connectors .....	3-61
3.2.6	Wire selection .....	3-62
3.2.6.1	Wire diameters and terminals / ferrules .....	3-62
3.2.6.2	Screw terminal block dimensions / screw and tightening torque specifications .....	3-63
3.2.6.3	Cable specifications.....	3-64
3.2.6.4	Waterproof connector specifications .....	3-64
3.3	Servo system wiring diagram .....	3-65
3.3.1	220V series models.....	3-65
400 W (and below) models.....	3-65	
750 W - 3 kW models.....	3-66	
4.5 kW - 15 kW models.....	3-67	
3.3.2	400V series models.....	3-68
400 W - 1.5 kW models .....	3-68	
2 kW - 15 kW models .....	3-69	
3.4	Wiring for CN1 I/O connector .....	3-70
3.4.1	A3-L and A3-M models – Wiring for CN1 I/O connector .....	3-70
3.4.1.1	A3-L and A3-M models – CN1 I/O connector .....	3-70
3.4.1.2	A3-L and A3-M models – Quick connector .....	3-77
3.4.1.3	A3-L and A3-M models – CN1 wiring diagrams .....	3-82
3.4.2	A3-E and A3-F models – Wiring for CN1 I/O connector .....	3-89
3.4.2.1	A3-E and A3-F models – CN1 I/O connector .....	3-89
3.4.2.2	A3-E and A3-F models – Quick connector .....	3-95
3.4.2.3	A3-E and A3-F models – CN1 wiring diagrams .....	3-99
3.5	Wiring for the CN2 encoder connector.....	3-102
3.6	Wiring for the CN3 connector (RS-485 / high-speed communication) .....	3-107
3.7	Wiring for CN4 connector (Mini USB).....	3-109

3.8	Wiring for CN5 connector (applicable to full-closed loop)	3-110
3.9	Wiring for CN6 connector	3-112
3.9.1	Wiring for the DMCNET communication connector	3-112
3.9.2	Wiring for the EtherCAT communication connector	3-114
3.10	CN10 STO (Safe Torque Off) function	3-117
3.10.1	Introduction to STO	3-117
3.10.2	Precautions for using STO function	3-117
3.10.3	Potential risks of STO	3-118
3.10.4	Safety parameters	3-119
3.10.5	How does the STO function work?	3-120
3.10.5.1	Response time	3-120
3.10.5.2	Alarm triggering	3-121
3.10.5.3	STO deactivation settings	3-123
3.10.6	Wiring for STO	3-128
3.10.6.1	CN10 STO connector	3-128
3.10.6.2	Input / output signal specification	3-129
3.10.6.3	Not using the STO function	3-130
3.10.6.4	Using the STO function for a single drive	3-130
3.10.6.5	Using the STO function for multiple drives	3-131
3.10.7	Validation test	3-132
3.11	220V series – Standard wiring example	3-133
3.11.1	Position (PT) control mode – differential line driver signal input	3-133
3.11.2	Position (PT) control mode – open-collector signal input	3-134
3.11.3	Position (PR) control mode – internal position commands	3-135
3.11.4	Speed (S) control mode	3-137
3.11.5	Torque (T) control mode	3-139
3.11.6	Communication mode (CANopen)	3-141
3.11.7	Communication mode (DMCNET)	3-142
3.11.8	Communication mode (EtherCAT)	3-143
3.12	400V series – Standard wiring example	3-144
3.12.1	Position (PT) control mode – differential line driver signal input	3-144
3.12.2	Position (PT) control mode – open-collector signal input	3-145
3.12.3	Position (PR) control mode – internal position commands	3-146
3.12.4	Speed (S) control mode	3-148
3.12.5	Torque (T) control mode	3-150
3.12.6	Communication mode (CANopen)	3-152
3.12.7	Communication mode (DMCNET)	3-153
3.12.8	Communication mode (EtherCAT)	3-154

# 3

## 3.1 220V series servo system connection

### 3.1.1 Connecting to peripheral devices (connecting to Delta communication type servo motor)

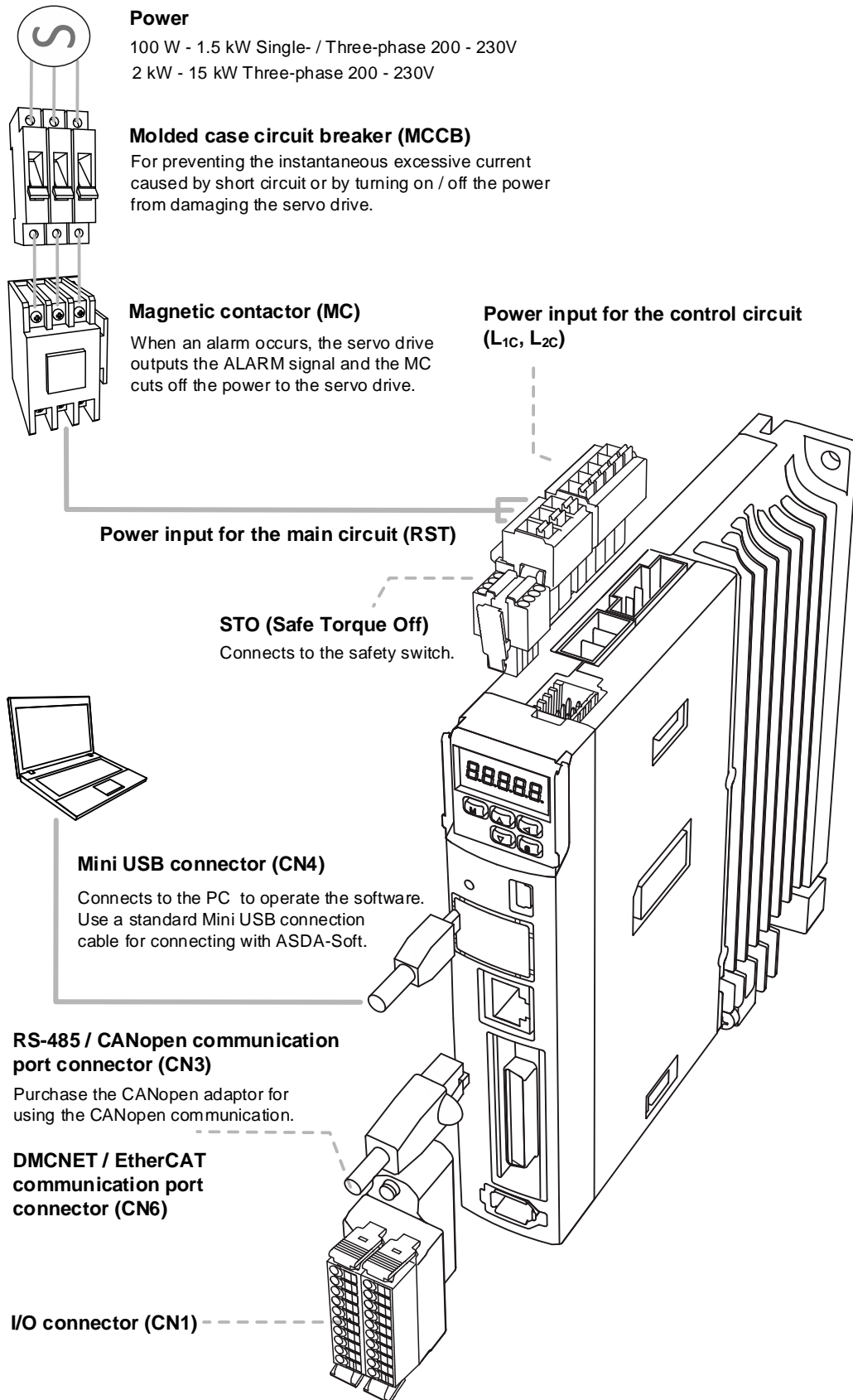

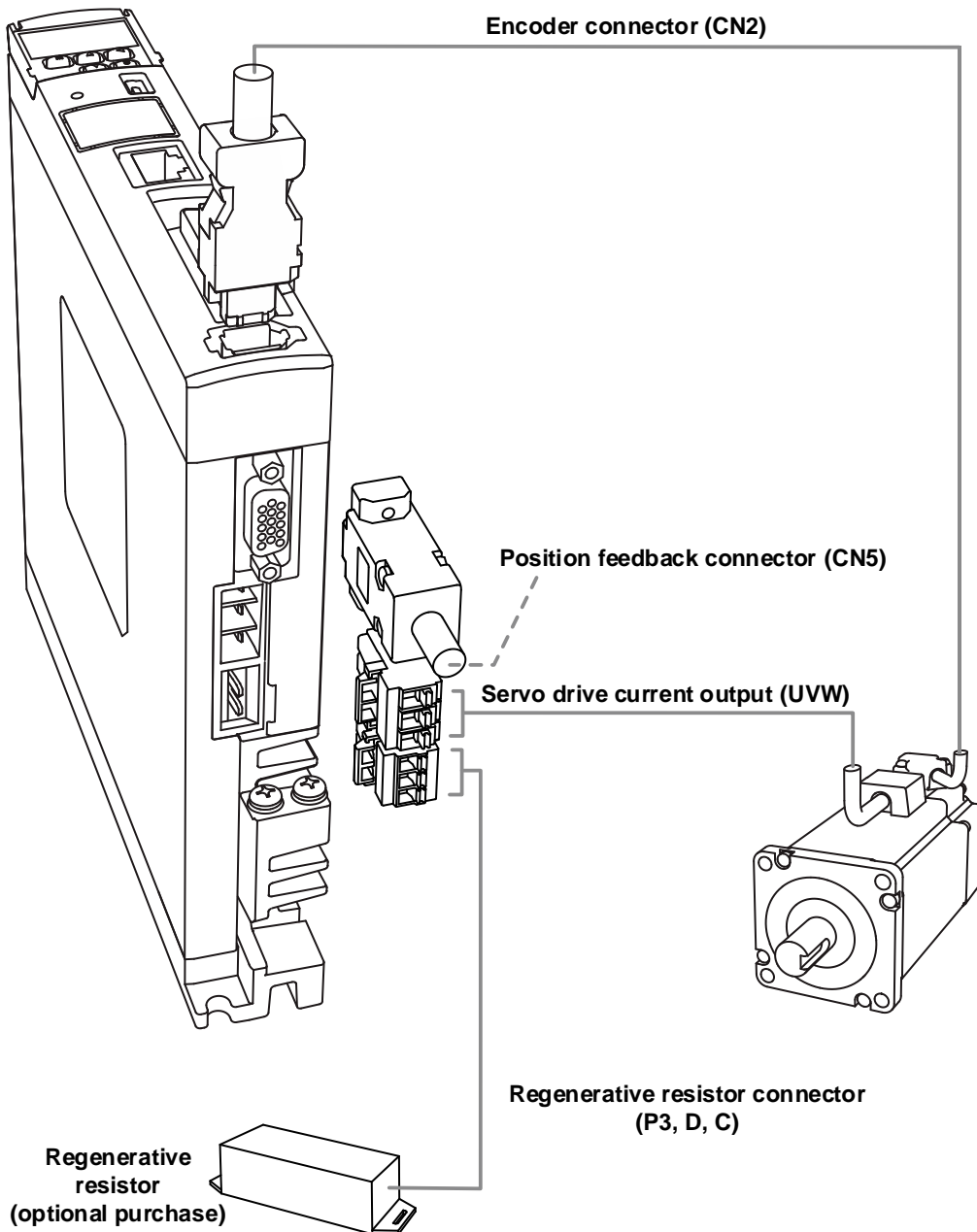

#### Installation precautions:

1. Make sure the power and wiring connections of the R, S, T, and L<sub>1C</sub>, L<sub>2C</sub> are correct. Refer to the specifications of the servo drives in Appendix A for the correct voltage input to avoid any damage to the servo drive and dangerous operating conditions.
2. Make sure the UVW terminal block is correctly wired to avoid abnormal operation of the motor.
3. When an external regenerative resistor is used, P3 and D contacts should be left open, and the external regenerative resistor should connect to P3 and C contacts. When the built-in regenerative resistor is used, P3 and D contacts should be short-circuited, and P3 and C contacts should be left open.
4. When an alarm occurs or the system is under emergency stop status, use DO.ALARM or DO.WARN to switch off the magnetic contactor (MC) to cut off the power to the servo drive.

### 3.1.2 Connectors and terminals

Terminal	Name	Description		
L1c, L2c	Power input for the control circuit	Connect to single-phase AC power. (Refer to the model specification for the proper input voltage.)		
P1, P2	-	Short-circuit P1 and P2.		
R, S, T	Power input for the main circuit	Connect to three-phase AC power. (Refer to the model specification for the proper input voltage.)		
U, V, W, FG	Motor power connector	Connect to the servo motor.		
		Terminal	Wire color	Description
		U	Red	A three-phase main power cable for the motor.
		V	White	
		W	Black	
FG	Yellow / Green	Connect to the ground terminal $\oplus$ for the servo drive.		
P3, D, C, $\ominus$	Regenerative resistor or regenerative unit	Use the built-in resistor	Short-circuit P3 and D contacts, and P3 and C contacts are left open.	
		Use an external resistor	Connect P3 and C contacts to the resistor, and P3 and D contacts are left open.	
		Use an external regenerative unit	Connect the regenerative unit to P3 and $\ominus$ on the servo drive. P3 & D contacts and P3 & C contacts are left open.	
$\oplus$	Ground terminals	Connect to the ground wire for the power and servo motor.		
CN1	I/O connector	Connect to the controller. Refer to Section 3.4 for more information.		
CN2	Encoder connector	Connect to the encoder or converter box. Refer to Section 3.5 for more information.		
CN3	Connector for RS-485 and CANopen	For RS-485 and CANopen communication. Refer to Section 3.6 for more information.		
CN4	Mini USB connector	Connect to PC or laptop. Refer to Section 3.7 for more information.		
CN5	Position feedback connector	Connect to an external linear scale or encoder for full-closed loop and motor feedback. Refer to Section 3.8 for more information.		
CN6	Connector for DMCNET / EtherCAT	For DMCNET or EtherCAT communication. Refer to Section 3.9 for more information.		
CN10	STO	For STO connection. Refer to Section 3.10 for more information.		

Pay special attention to the following when wiring:

1. Do not touch R, S, T and U, V, W immediately after the power is off since the capacitance inside the servo drive can still contain a dangerously large amount of electric charge. Wait until the charging light is off.
2. Separate R, S, T and U, V, W from other wires. The separation should be at least 30 cm (11.8 inches).
3. For the connection cable for CN2 and CN5, use a metal braided shielded twisted-pair cable that conforms to UL2464 specifications.
4. When using RS-485, CANopen, DMCNET, or EtherCAT, use the shielded twisted-pair communication cable to ensure the communication quality.
5. When selecting the wires, refer to Section 3.1.6.
6. Do not use any external capacitor, or it may damage the servo drive.



3

3.1.3 Wiring for power supply

There are two methods for wiring the power supply: single-phase and three-phase. The single-phase wiring is only applicable to models of 220V 1.5 kW or below. In the following diagram, Power 1 and ALRM\_RY\_A are normally open contacts, and Power 2 is a normally closed contact. MC (magnetic contactor) is the power relay and the contact for the main power circuit.

- Wiring method for single-phase power supply (for models of 220V 1.5 kW or below)

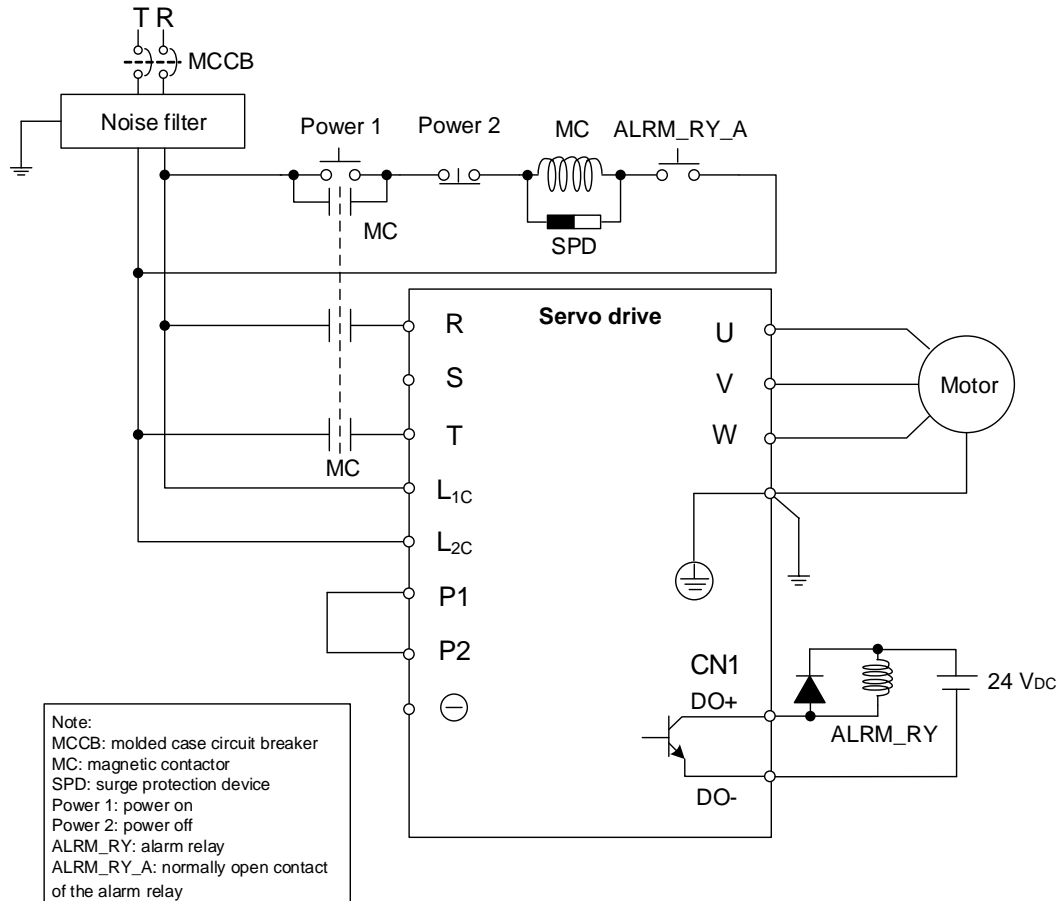

Note: wire the CN1 connector with the actual DO parameters of each model.

■ Wiring method for three-phase power supply (for all 220V series)

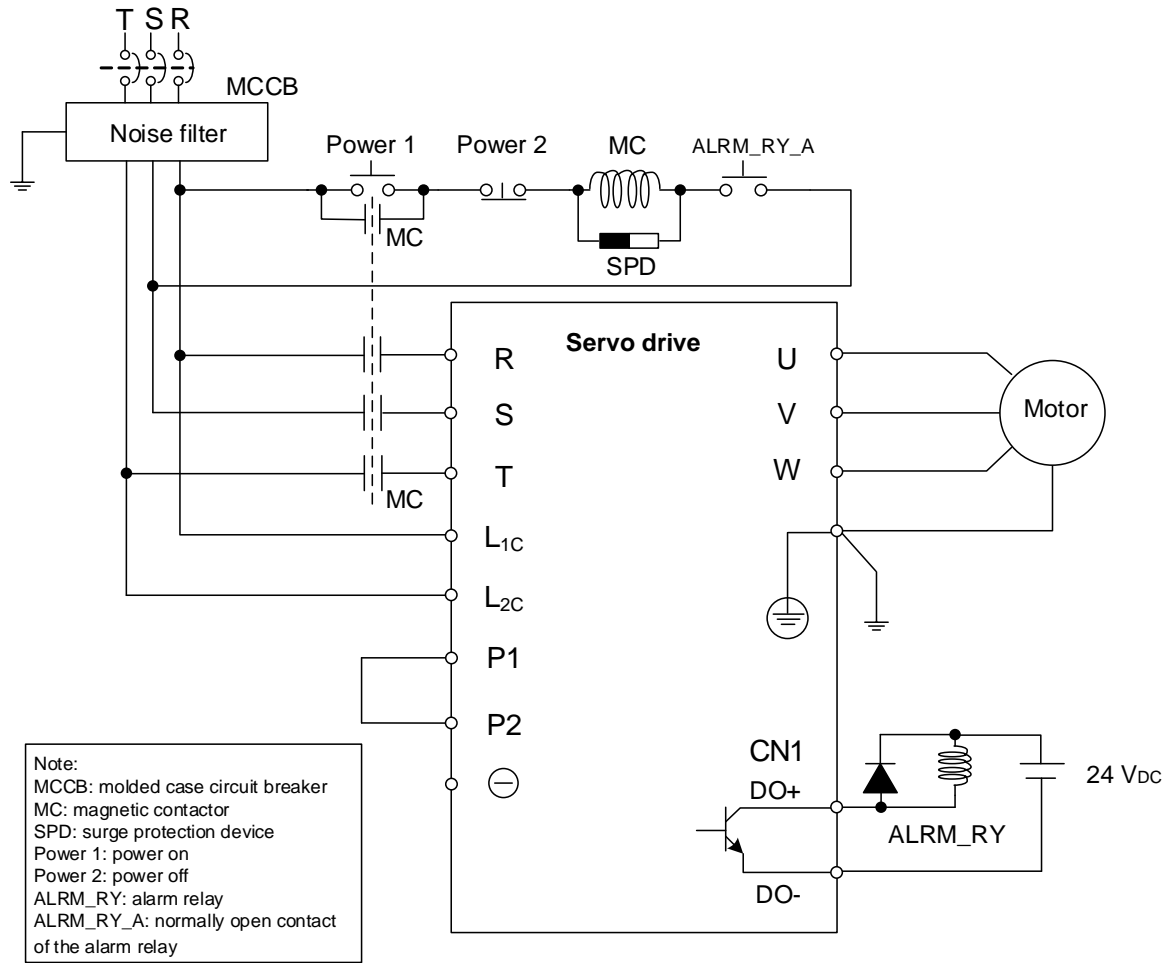

Note: wire the CN1 connector with the actual DO parameters of each model.

# 3

■ Connecting multiple servo drives (in parallel)

Using a common DC Bus can make efficient use of the regenerative energy. For instance, while one of the axes is decelerating, the regenerative energy can be supplied to other axes. If you need to connect servo drives of different power levels, only models of similar power levels can be connected; moreover, each servo drive should connect to a regenerative resistor (or regenerative unit).

Example: if there is a 400 W servo drive in the current system, you can add servo drives of the same or different power level which ranges from 200 W to 750 W. This is because the system can only contain servo drives of up to two different power levels.

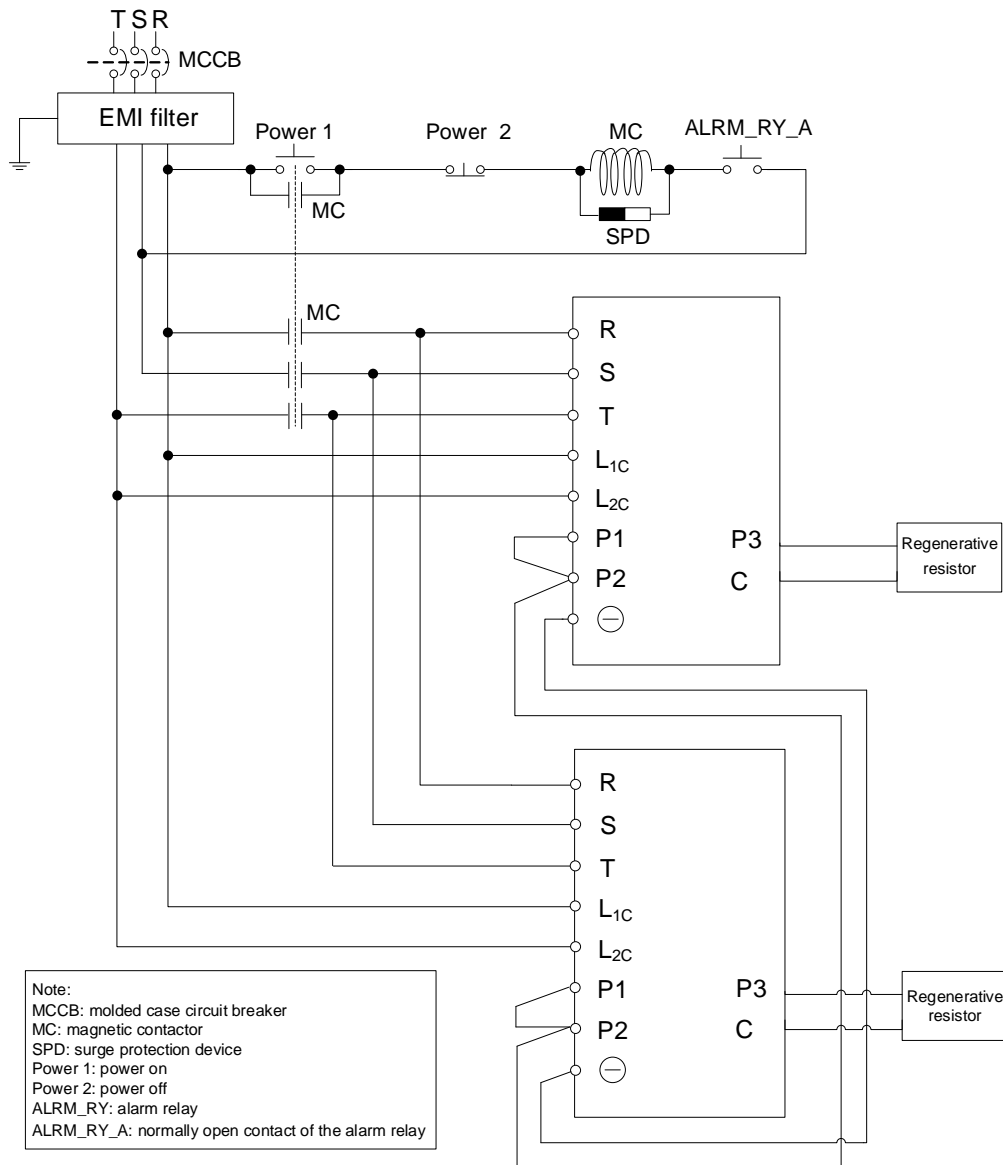

### 3.1.4 UVW power connector specifications

Select the appropriate connector according to the code of **Shaft diameter and connector type** in the servo motor model name. Refer to Section 1.2.2 for the model explanation of the servo motor.

3

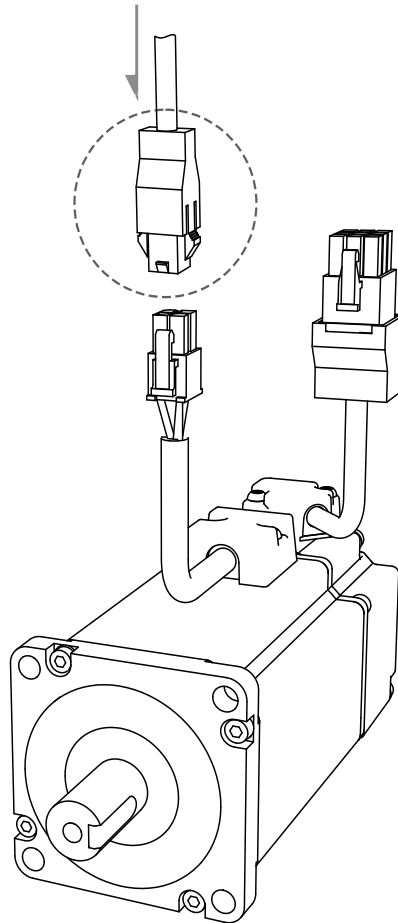

The (2) and (3) in the following figure show the difference between the military connectors of the ECM-B3 motors and those of the ECMA / ECMC (old series) motors.

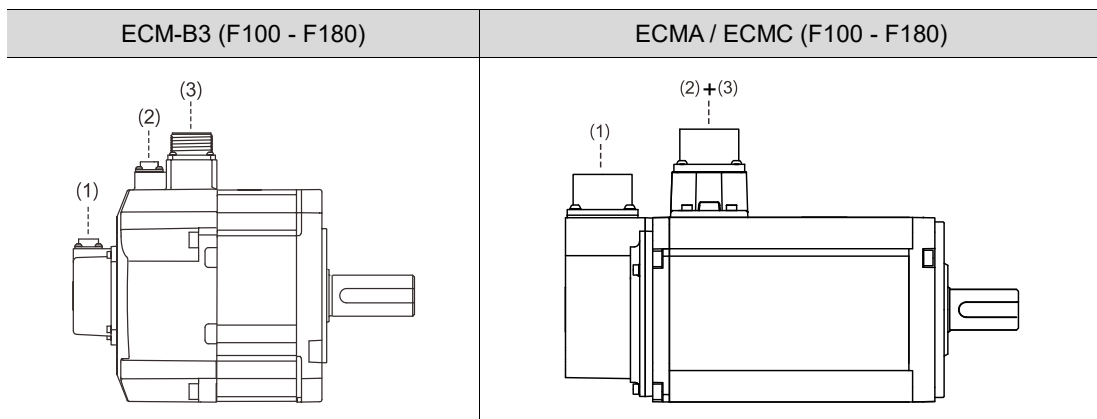

(1) Encoder connector; (2) Brake connector; (3) UVW power connector

3.1.4.1 F40 - F80 motors – Power connectors

Motor model	UVW connector					
ECM-A3 <sup>1</sup> -C <sup>2</sup> 2040F <sup>3</sup> <sup>4</sup> <sup>5</sup>						
ECM-A3 <sup>1</sup> -C <sup>2</sup> 20401 <sup>3</sup> <sup>4</sup> <sup>5</sup>						
ECM-A3 <sup>1</sup> -C <sup>2</sup> 20602 <sup>3</sup> <sup>4</sup> <sup>5</sup>						
ECM-A3 <sup>1</sup> -C <sup>2</sup> 20604 <sup>3</sup> <sup>4</sup> <sup>5</sup>						
ECM-A3 <sup>1</sup> -C <sup>2</sup> 20804 <sup>3</sup> <sup>4</sup> <sup>5</sup>						
ECM-A3 <sup>1</sup> -C <sup>2</sup> 20807 <sup>3</sup> <sup>4</sup> <sup>5</sup>						
ECM-B3 <sup>1</sup> -C <sup>2</sup> 20401 <sup>3</sup> <sup>4</sup> <sup>5</sup>						
ECM-B3 <sup>1</sup> -C <sup>2</sup> 20602 <sup>3</sup> <sup>4</sup> <sup>5</sup>						
ECM-B3 <sup>1</sup> -C <sup>2</sup> 20604 <sup>3</sup> <sup>4</sup> <sup>5</sup>						
ECM-B3 <sup>1</sup> -C <sup>2</sup> 20804 <sup>3</sup> <sup>4</sup> <sup>5</sup>						
ECM-B3 <sup>1</sup> -C <sup>2</sup> 20807 <sup>3</sup> <sup>4</sup> <sup>5</sup>						
ECM-B3 <sup>1</sup> -C <sup>2</sup> 20810 <sup>3</sup> <sup>4</sup> <sup>5</sup>						
	Pin assignment					
	U (Red)	V (White)	W (Black)	CASE GROUND (Yellow / Green)	BRAKE1	BRAKE2
	1	2	3	4	-	-
	Pin assignment					
	U (Red)	V (White)	W (Black)	CASE GROUND (Yellow / Green)	BRAKE1 <sup>3</sup>	BRAKE2 <sup>3</sup>
	1	2	4	5	3	6

Note:

1. In the servo motor model name, <sup>1</sup> represents the motor inertia, <sup>2</sup> represents the encoder type, <sup>3</sup> represents the brake or keyway / oil seal type, <sup>4</sup> represents the shaft diameter and connector type, and <sup>5</sup> represents the special code.
2. Power supply for the brake is 24 V<sub>DC</sub>. Do not share the same power supply with control signals.
3. The brake coil has no polarity. Its pin symbols are BRAKE1 and BRAKE2. Brake cable colors for motors with the frame size of 40 - 80 mm: brown and blue.
4. When selecting the wires, refer to Section 3.1.6 for details.

Connector specifications:

UVW	Brand	Model name
	Delta	ACS3-CAPW1000
	Molex	39-01-2041 (case) 39-00-0040 (terminal)
UVW with brake	Brand	Model name
	Delta	ACS3-CAPW2000
	Molex	39-01-2061 (case) 39-00-0040 (terminal)

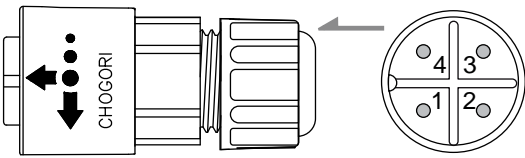
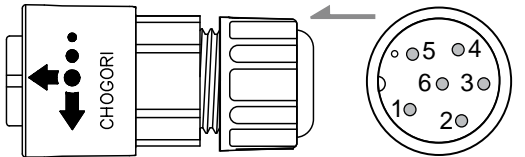
Motor model	UVW connector					
ECM-A3 <sup>1</sup> -C <sup>2</sup> 040F <sup>3</sup> <sup>4</sup> <sup>5</sup> ECM-A3 <sup>1</sup> -C <sup>2</sup> 0401 <sup>3</sup> <sup>4</sup> <sup>5</sup> ECM-A3 <sup>1</sup> -C <sup>2</sup> 0602 <sup>3</sup> <sup>4</sup> <sup>5</sup> ECM-A3 <sup>1</sup> -C <sup>2</sup> 0604 <sup>3</sup> <sup>4</sup> <sup>5</sup> ECM-A3 <sup>1</sup> -C <sup>2</sup> 0804 <sup>3</sup> <sup>4</sup> <sup>5</sup> ECM-A3 <sup>1</sup> -C <sup>2</sup> 0807 <sup>3</sup> <sup>4</sup> <sup>5</sup>						
	Pin assignment					
	U (Red)	V (White)	W (Black)	CASE GROUND (Yellow / Green)	BRAKE1	BRAKE2
	1	2	3	4	-	-
						
ECM-B3 <sup>1</sup> -C <sup>2</sup> 0401 <sup>3</sup> <sup>4</sup> <sup>5</sup> ECM-B3 <sup>1</sup> -C <sup>2</sup> 0602 <sup>3</sup> <sup>4</sup> <sup>5</sup> ECM-B3 <sup>1</sup> -C <sup>2</sup> 0604 <sup>3</sup> <sup>4</sup> <sup>5</sup> ECM-B3 <sup>1</sup> -C <sup>2</sup> 0804 <sup>3</sup> <sup>4</sup> <sup>5</sup> ECM-B3 <sup>1</sup> -C <sup>2</sup> 0807 <sup>3</sup> <sup>4</sup> <sup>5</sup> ECM-B3 <sup>1</sup> -C <sup>2</sup> 0810 <sup>3</sup> <sup>4</sup> <sup>5</sup>	Pin assignment					
	U (Red)	V (White)	W (Black)	CASE GROUND (Yellow / Green)	BRAKE1 <sup>3</sup>	BRAKE2 <sup>3</sup>
	1	2	3	4	5	6

Note:

1. In the servo motor model name, <sup>1</sup> represents the motor inertia, <sup>2</sup> represents the encoder type, <sup>3</sup> represents the brake or keyway / oil seal type, <sup>4</sup> represents the shaft diameter and connector type, and <sup>5</sup> represents the special code.
2. Power supply for the brake is 24 V<sub>DC</sub>. Do not share the same power supply with control signals.
3. The brake coil has no polarity. Its pin symbols are BRAKE1 and BRAKE2. Color of brake cable for motors with the frame size of 40 - 80 mm: brown and blue.
4. When selecting the wires, refer to Section 3.1.6 for details.

Connector specifications:

UVW	Brand	Model name	IP rating
	Delta	ACS3-CNPW1A00	IP67
	CHOGORI	23004231-02	IP67

UVW with brake	Brand	Model name	IP rating
	Delta	ACS3-CNPW2A00	IP67
	CHOGORI	23006231-02	IP67

Note: refer to Section 3.1.7 for the diameter specification of the IP67 compliant Delta connectors. For connector specification of other brands, contact the manufacturers.

3

Motor model	UVW connector					
ECM-B3 <sup>1</sup> -C <sup>2</sup> 20401 <sup>3</sup> 4 <sup>5</sup> ECM-B3 <sup>1</sup> -C <sup>2</sup> 20602 <sup>3</sup> 4 <sup>5</sup> ECM-B3 <sup>1</sup> -C <sup>2</sup> 20604 <sup>3</sup> 4 <sup>5</sup> ECM-B3 <sup>1</sup> -C <sup>2</sup> 20804 <sup>3</sup> 4 <sup>5</sup> ECM-B3 <sup>1</sup> -C <sup>2</sup> 20807 <sup>3</sup> 4 <sup>5</sup> ECM-B3 <sup>1</sup> -C <sup>2</sup> 20810 <sup>3</sup> 4 <sup>5</sup>	Cable exit direction towards motor shaft					
	Cable exit direction towards encoder					
Pin assignment						
U (Red)	V (White)	W (Black)	CASE GROUND (Yellow / Green)	BRAKE1 <sup>3</sup> *5	BRAKE2 <sup>3</sup> *5	
1	2	3	4	A	B	

Note:

- In the servo motor model name, <sup>1</sup> represents the motor inertia, <sup>2</sup> represents the encoder type, <sup>3</sup> represents the brake or keyway / oil seal type, <sup>4</sup> represents the shaft diameter and connector type, and <sup>5</sup> represents the special code.
- Power supply for the brake is 24 V<sub>DC</sub>. Do not share the same power supply with control signals.
- The brake coil has no polarity. Its pin symbols are BRAKE1 and BRAKE2. Color of brake cable for motors with the frame size of 40 - 80 mm: brown and blue.
- When selecting the wires, refer to Section 3.1.6 for details.
- All bulkhead connectors are with brakes. Do not wire Pin A and Pin B when using the motors without brakes.

Connector specifications:

UVW with brake	Brand	Model name	IP rating
Bulkhead connector - cable exit direction towards motor shaft	Delta	ACS3-AFPWSS00	IP67
	SUNCHU	SC-ACS3-AFPWSS00	IP67
Bulkhead connector - cable exit direction towards encoder	Delta	ACS3-ABPWSS00	IP67
	SUNCHU	SC-ACS3-ABPWSS00	IP67

Note: refer to Section 3.1.7 for the diameter specification of the IP67 compliant Delta connectors. For connector specification of other brands, contact the manufacturers.

## 3.1.4.2 F100 - F130 motors – Power connectors

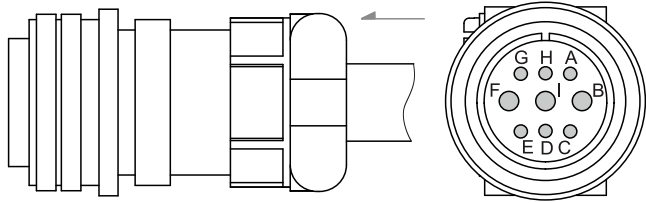
Motor model	UVW connector					
ECMC-F <sup>2</sup> 1308 <sup>3</sup> <sup>4</sup>						
ECMC-C <sup>2</sup> 1010 <sup>3</sup> <sup>4</sup>						
ECMC-E <sup>2</sup> 1310 <sup>3</sup> <sup>4</sup>						
ECMC-F <sup>2</sup> 1313 <sup>3</sup> <sup>4</sup>						
ECMC-E <sup>2</sup> 1315 <sup>3</sup> <sup>4</sup>						
ECMC-F <sup>2</sup> 1318 <sup>3</sup> <sup>4</sup>						
ECMC-E <sup>2</sup> 1320 <sup>3</sup> <sup>4</sup>						
	Pin assignment					
	U (Red)	V (White)	W (Black)	CASE GROUND (Yellow / Green)	BRAKE1 <sup>3</sup>	BRAKE2 <sup>3</sup>
	F	I	B	E	G	H

## Note:

1. In the servo motor model number, <sup>2</sup> represents the encoder type, <sup>3</sup> represents the brake or keyway / oil seal type, and <sup>4</sup> represents the shaft diameter and connector type.
2. Power supply for the brake is 24 V<sub>DC</sub>. Do not share the same power supply with control signals.
3. The brake coil has no polarity. Its pin symbols are BRAKE1 and BRAKE2. Color of brake cable for motors with the frame size of 100 mm or above: red and black.
4. When selecting the wires, refer to Section 3.1.6 for details.

## Connector specifications:

UVW with brake	Brand	Model name	IP rating
MIL 20-18	Delta	ASD-CAPW1000	IP65
	SUNCHU	CMS3106A-20-18SBI (connector)	IP65
	PLT	WPS3106A-20-18S (connector) WPS3057-12A-R (cable clamp)	IP65



3

Motor model	UVW connector																							
ECM-B3 <sup>1</sup> -C <sup>2</sup> 1010 <sup>3</sup> 4 <sup>4</sup> 5 <sup>5</sup>																								
ECM-B3 <sup>1</sup> -C <sup>2</sup> 1015 <sup>3</sup> 4 <sup>4</sup> 5 <sup>5</sup>																								
ECM-B3 <sup>1</sup> -C <sup>2</sup> 1020 <sup>3</sup> 4 <sup>4</sup> 5 <sup>5</sup>																								
ECM-B3 <sup>1</sup> -E <sup>2</sup> 1310 <sup>3</sup> 4 <sup>4</sup> 5 <sup>5</sup>																								
ECM-B3 <sup>1</sup> -E <sup>2</sup> 1315 <sup>3</sup> 4 <sup>4</sup> 5 <sup>5</sup>																								
ECM-B3 <sup>1</sup> -E <sup>2</sup> 1320 <sup>3</sup> 4 <sup>4</sup> 5 <sup>5</sup>																								
ECM-B3 <sup>1</sup> -F <sup>2</sup> 1308 <sup>3</sup> 4 <sup>4</sup> 5 <sup>5</sup>	<table border="1"> <thead> <tr> <th colspan="6">Pin assignment</th> </tr> <tr> <th>U (Red)</th> <th>V (White)</th> <th>W (Black)</th> <th>CASE GROUND (Yellow / Green)</th> <th>BRAKE1<sup>3</sup></th> <th>BRAKE2<sup>3</sup></th> </tr> <tr> <th>A</th> <th>B</th> <th>C</th> <th>D</th> <th>1</th> <th>2</th> </tr> </thead> </table>						Pin assignment						U (Red)	V (White)	W (Black)	CASE GROUND (Yellow / Green)	BRAKE1 <sup>3</sup>	BRAKE2 <sup>3</sup>	A	B	C	D	1	2
Pin assignment																								
U (Red)							V (White)	W (Black)	CASE GROUND (Yellow / Green)	BRAKE1 <sup>3</sup>	BRAKE2 <sup>3</sup>													
A							B	C	D	1	2													
ECM-B3 <sup>1</sup> -F <sup>2</sup> 1313 <sup>3</sup> 4 <sup>4</sup> 5 <sup>5</sup>																								
ECM-B3 <sup>1</sup> -F <sup>2</sup> 1318 <sup>3</sup> 4 <sup>4</sup> 5 <sup>5</sup>																								
ECM-B3 <sup>1</sup> -F <sup>2</sup> 1318 <sup>3</sup> 4 <sup>4</sup> 5 <sup>5</sup>																								

Note:

1. In the servo motor model name, <sup>1</sup> represents the motor inertia, <sup>2</sup> represents the encoder type, <sup>3</sup> represents the brake or keyway / oil seal type, <sup>4</sup> represents the shaft diameter and connector type, and <sup>5</sup> represents the special code.
2. Power supply for the brake is 24 V<sub>DC</sub>. Do not share the same power supply with control signals.
3. The brake coil has no polarity. Its pin symbols are BRAKE1 and BRAKE2. Color of brake cable for motors with the frame size of 100 mm or above: red and black.
4. When selecting the wires, refer to Section 3.1.6 for details. For the wiring instructions of IP67 connectors, refer to Section 3.1.7.

Connector specifications:

UVW	Brand	Model name	IP rating
MIL 18-10S	Delta	ACS3-CAPWA000	IP67
	SUNCHU	CMS3106A18-10SBI (connector & compression ring)	IP67

Brake	Brand	Model name	IP rating
CMV1-2S	Delta	ACS3-CABRA000 (bayonet) ACS3-CABRM000 (threaded)	IP67
	DDK <sup>*2</sup>	CM1V1-SP2S-M1 (bayonet)	IP67
	Suntone <sup>*3</sup>	SM10-SP2S-M1-D6-V (bayonet) SM10H-SP2S-M1-D6-V (threaded)	IP67

Note:

1. Refer to Section 3.1.7 for the diameter specification of the IP67 compliant Delta connectors. For connector specification of other brands, contact the manufacturers.
2. The contacts, solder contacts (CMV1-#22BSC-S2-100) or crimp contacts (CMV1-#22BSC-C3-100), for the listed DDK connector are sold separately.
3. The contacts, solder contacts (SMS-5012 or SMS-5013) or crimp contacts (SMS-5011), for the listed Suntone connectors are sold separately.

Motor model	UVW connector					
ECM-B3 <sup>1</sup> -C <sup>2</sup> 1010 <sup>3</sup> 4 <sup>5</sup>						
ECM-B3 <sup>1</sup> -C <sup>2</sup> 1015 <sup>3</sup> 4 <sup>5</sup>						
ECM-B3 <sup>1</sup> -C <sup>2</sup> 1020 <sup>3</sup> 4 <sup>5</sup>						
ECM-B3 <sup>1</sup> -E <sup>2</sup> 1310 <sup>3</sup> 4 <sup>5</sup>						
ECM-B3 <sup>1</sup> -E <sup>2</sup> 1315 <sup>3</sup> 4 <sup>5</sup>						
ECM-B3 <sup>1</sup> -E <sup>2</sup> 1320 <sup>3</sup> 4 <sup>5</sup>						
ECM-B3 <sup>1</sup> -F <sup>2</sup> 1308 <sup>3</sup> 4 <sup>5</sup>						
ECM-B3 <sup>1</sup> -F <sup>2</sup> 1313 <sup>3</sup> 4 <sup>5</sup>						
ECM-B3 <sup>1</sup> -F <sup>2</sup> 1318 <sup>3</sup> 4 <sup>5</sup>	Pin assignment					
	U (Red)	V (White)	W (Black)	CASE GROUND (Yellow / Green)	BRAKE1 <sup>3</sup>	BRAKE2 <sup>3</sup>
	A	B	C	D	1	2

Note:

1. In the servo motor model name, <sup>1</sup> represents the motor inertia, <sup>2</sup> represents the encoder type, <sup>3</sup> represents the brake or keyway / oil seal type, <sup>4</sup> represents the shaft diameter and connector type, and <sup>5</sup> represents the special code.
2. Power supply for the brake is 24 V<sub>DC</sub>. Do not share the same power supply with control signals.
3. The brake coil has no polarity. Its pin symbols are BRAKE1 and BRAKE2. Color of brake cable for motors with the frame size of 100 mm or above: red and black.
4. When selecting the wires, refer to Section 3.1.6 for details.

Connector specifications:

UVW	Brand	Model name	IP rating
MIL 18-10S	Delta	ACS3-CRPWA000	IP67
	SUNCHU	CMS3108A18-10SBI (connector & compression ring)	IP67

Brake	Brand	Model name	IP rating
CMV1-2S	Delta	ACS3-CRBRA000 (bayonet) ACS3-CRBRM000 (threaded)	IP67
	DDK <sup>*2</sup>	CMV1-AP2S-M1 (bayonet)	IP67
	Suntone <sup>*3</sup>	SM10-AP2S-M1-D6-V (bayonet) SM10H-AP2S-M1-D6-V (threaded)	IP67

Note:

1. Refer to Section 3.1.7 for the diameter specification of the IP67-compliant Delta connectors. For connector specification of other brands, contact the manufacturers.
2. The contacts, solder contacts (CMV1-#22BSC-S2-100) or crimp contacts (CMV1-#22BSC-C3-100), for the listed DDK connector are sold separately.
3. The contacts, solder contacts (SMS-5012 or SMS-5013) or crimp contacts (SMS-5011), for the listed Suntone connectors are sold separately.

3.1.4.3 F180 4.5 kW (or below) motors – Power connectors

3

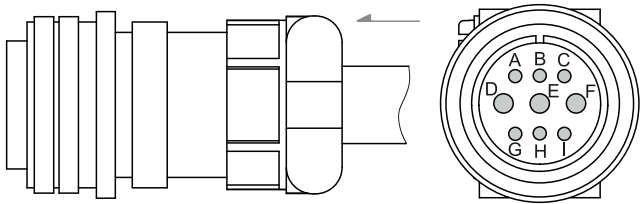
Motor model	UVW connector					
ECMC-E <sup>2</sup> 1820 <sup>3</sup> <sup>4</sup> ECMC-E <sup>2</sup> 1830 <sup>3</sup> <sup>4</sup> ECMC-F <sup>2</sup> 1830 <sup>3</sup> <sup>4</sup>						
	Recommended brand		Model number of the U/V/W end			
	Delta		ASD-CAPW2000			
	SUNCHU		CMS3106A24-11SBI (connector & compression ring)			
	PLT		WPS3106A24-11S-R (connector) WPS3057-16A-R (cable clamp)			
	Pin assignment					
U (Red)	V (White)	W (Black)	CASE GROUND (Yellow / Green)	BRAKE1 <sup>3</sup>	BRAKE2 <sup>3</sup>	
D	E	F	G	A	B	

Note:

1. In the servo motor model name, <sup>1</sup> represents the motor inertia, <sup>2</sup> represents the encoder type, <sup>3</sup> represents the brake or keyway / oil seal type, <sup>4</sup> represents the shaft diameter and connector type, and <sup>5</sup> represents the special code.
2. Power supply for the brake is 24 V<sub>DC</sub>. Do not share the same power supply with control signals.
3. The brake coil has no polarity. Its pin symbols are BRAKE1 and BRAKE2. Color of brake cable for motors with the frame size of 100 mm or above: red and black.
4. When selecting the wires, refer to Section 3.1.6 for details.

Connector specifications:

UVW with brake	Brand	Model name	IP rating
MIL 24-11S	Delta	ASD-CAPW2000	IP65
	SUNCHU	CMS3106A24-11SBI (connector & compression ring)	IP65
	PLT	WPS3106A24-11S-R (connector) WPS3057-16A-R (cable clamp)	IP65

Note: refer to Section 3.1.7. for the diameter specification of the IP65-compliant Delta connectors. For connector specification of other brands, contact the manufacturers.

Motor model	UVW connector					
ECM-B3 <sup>1</sup> -E <sup>2</sup> 1820 <sup>3</sup> <sup>4</sup> <sup>5</sup> ECM-B3 <sup>1</sup> -F <sup>2</sup> 1830 <sup>3</sup> <sup>4</sup> <sup>5</sup> ECM-B3 <sup>1</sup> -F <sup>2</sup> 1845 <sup>3</sup> <sup>4</sup> <sup>5</sup>						
	Pin assignment					
	U (Red)	V (White)	W (Black)	CASE GROUND (Yellow / Green)	BRAKE1 <sup>3</sup>	BRAKE2 <sup>3</sup>
A	B	C	D	1	2	

Note:

1. In the servo motor model name, <sup>1</sup> represents the motor inertia, <sup>2</sup> represents the encoder type, <sup>3</sup> represents the brake or keyway / oil seal type, <sup>4</sup> represents the shaft diameter and connector type, and <sup>5</sup> represents the special code.
2. Power supply for the brake is 24 V<sub>DC</sub>. Do not share the same power supply with control signals.
3. The brake coil has no polarity. Its pin symbols are BRAKE1 and BRAKE2. Color of brake cable for motors with the frame size of 100 mm or above: red and black.
4. When selecting the wires, refer to Section 3.1.6 for details.

Connector specifications:

UVW	Brand	Model name	IP rating
MIL 22-22S	Delta	ACS3-CAPWC000	IP67
	SUNCHU	CMS3106A22-22SBI (connector & compression ring)	IP67

Brake	Brand	Model name	IP rating
CMV1-2S	Delta	ACS3-CABRA000 (bayonet) ACS3-CABRM000 (threaded)	IP67
	DDK <sup>2</sup>	CM1V1-SP2S-M1 (bayonet)	IP67
	Suntone <sup>3</sup>	SM10-SP2S-M1-D6-V (bayonet) SM10H-SP2S-M1-D6-V (threaded)	IP67

Note:

1. Refer to Section 3.1.7 for the diameter specification of the IP67-compliant Delta connectors. For connector specification of other brands, contact the manufacturers.
2. The contacts, solder contacts (CMV1-#22BSC-S2-100) or crimp contacts (CMV1-#22BSC-C3-100), for the listed DDK connector are sold separately.
3. The contacts, solder contacts (SMS-5012 or SMS-5013) or crimp contacts (SMS-5011), for the listed Suntone connectors are sold separately.

3

Motor model	UVW connector					
ECM-B3 <sup>1</sup> -E <sup>2</sup> 1820 <sup>3</sup> <sup>4</sup> <sup>5</sup> ECM-B3 <sup>1</sup> -F <sup>2</sup> 1830 <sup>3</sup> <sup>4</sup> <sup>5</sup> ECM-B3 <sup>1</sup> -F <sup>2</sup> 1845 <sup>3</sup> <sup>4</sup> <sup>5</sup>						
Pin assignment						
U (Red)	V (White)	W (Black)	CASE GROUND (Yellow / Green)	BRAKE1 <sup>3</sup>	BRAKE2 <sup>3</sup>	
A	B	C	D	1	2	

Note:

1. In the servo motor model name, <sup>1</sup> represents the motor inertia, <sup>2</sup> represents the encoder type, <sup>3</sup> represents the brake or keyway / oil seal type, <sup>4</sup> represents the shaft diameter and connector type, and <sup>5</sup> represents the special code.
2. Power supply for the brake is 24 V<sub>DC</sub>. Do not share the same power supply with control signals.
3. The brake coil has no polarity. Its pin symbols are BRAKE1 and BRAKE2. Color of brake cable for motors with the frame size of 100 mm or above: red and black.
4. When selecting the wires, refer to Section 3.1.6 for details.

Connector specifications:

UVW	Brand	Model name	IP rating
MIL 22-22S	Delta	ACS3-CRPWC000	IP67
	SUNCHU	CMS3108A22-22SBI (connector & compression ring)	IP67

Brake	Brand	Model name	IP rating
CMV1-2S	Delta	ACS3-CRBRA000 (bayonet) ACS3-CRBRM000 (threaded)	IP67
	DDK <sup>2</sup>	CMV1-AP2S-M1 (bayonet)	IP67
	Suntone <sup>3</sup>	SM10-AP2S-M1-D6-V (bayonet)	IP67
		SM10H-AP2S-M1-D6-V (threaded)	IP67

Note:

1. Refer to Section 3.1.7 for the diameter specification of the IP67-compliant Delta connectors. For connector specification of other brands, contact the manufacturers.
2. The contacts, solder contacts (CMV1-#22BSC-S2-100) or crimp contacts (CMV1-#22BSC-C3-100), for the listed DDK connector are sold separately.
3. The contacts, solder contacts (SMS-5012 or SMS-5013) or crimp contacts (SMS-5011), for the listed Suntone connectors are sold separately.

3.1.4.4 F180 5.5 kW (or above) & F220 motors – Power connectors

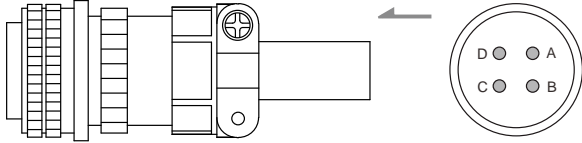
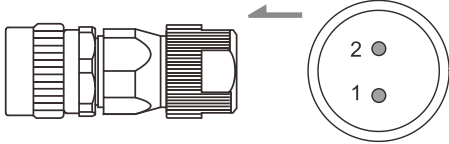
Motor model	UVW connector					
ECM-B3 <sup>1</sup> -F <sup>2</sup> 1855 <sup>3</sup> <sup>4</sup> <sup>5</sup> ECM-B3 <sup>1</sup> -F <sup>2</sup> 1875 <sup>3</sup> <sup>4</sup> <sup>5</sup> ECM-B3 <sup>1</sup> -F <sup>2</sup> 221B <sup>3</sup> <sup>4</sup> <sup>5</sup> ECM-B3 <sup>1</sup> -F <sup>2</sup> 221F <sup>3</sup> <sup>4</sup> <sup>5</sup>						
						
	Pin assignment					
U (Red)	V (White)	W (Black)	CASE GROUND (Yellow / Green)	BRAKE1 <sup>3</sup>	BRAKE2 <sup>3</sup>	
A	B	C	D	1	2	

Note:

1. In the servo motor model name, <sup>1</sup> represents the motor inertia, <sup>2</sup> represents the encoder type, <sup>3</sup> represents the brake or keyway / oil seal type, <sup>4</sup> represents the shaft diameter and connector type, and <sup>5</sup> represents the special code.
2. Power supply for the brake is 24 V<sub>DC</sub>. Do not share the same power supply with control signals.
3. The brake coil has no polarity. Its pin symbols are BRAKE1 and BRAKE2. Color of brake cable for motors with the frame size of 100 mm or above: red and black.
4. When selecting the wires, refer to Section 3.1.6 for details.

Connector specifications:

UVW	Brand	Model name	IP rating
MIL 32-17S	Delta	ACS3-CAPWE000	IP42
	SUNCHU	CMS3106A32-17S (connector & compression ring)	IP42
	PLT	WPS3106A32-17S-R (connector) AMS3057-20A-R (cable clamp)	IP65
Brake	Brand	Model name	IP rating
CMV1-2S	Delta	ACS3-CABRA000 (bayonet) ACS3-CABRM000 (threaded)	IP67
	DDK <sup>*2</sup>	CM1V1-SP2S-M1 (bayonet)	IP67
	Suntone <sup>*3</sup>	SM10-SP2S-M1-D6-V (bayonet) SM10H-SP2S-M1-D6-V (threaded)	IP67

Note:

1. Refer to Section 3.1.7 for the diameter specification of the IP67- and IP42-compliant Delta connectors. For connector specification of other brands, contact the manufacturers.
2. The contacts, solder contacts (CMV1-#22BSC-S2-100) or crimp contacts (CMV1-#22BSC-C3-100), for the listed DDK connector are sold separately.
3. The contacts, solder contacts (SMS-5012 or SMS-5013) or crimp contacts (SMS-5011), for the listed Suntone connectors are sold separately.

3

Motor model	UVW connector					
ECM-B3 <sup>1</sup> -F <sup>2</sup> 1855 <sup>3</sup> <sup>4</sup> <sup>5</sup> ECM-B3 <sup>1</sup> -F <sup>2</sup> 1875 <sup>3</sup> <sup>4</sup> <sup>5</sup> ECM-B3 <sup>1</sup> -F <sup>2</sup> 2221B <sup>3</sup> <sup>4</sup> <sup>5</sup> ECM-B3 <sup>1</sup> -F <sup>2</sup> 2221F <sup>3</sup> <sup>4</sup> <sup>5</sup>						
Pin assignment						
U (Red)	V (White)	W (Black)	CASE GROUND (Yellow / Green)	BRAKE1 <sup>3</sup>	BRAKE2 <sup>3</sup>	
A	B	C	D	1	2	

Note:

1. In the servo motor model name, <sup>1</sup> represents the motor inertia, <sup>2</sup> represents the encoder type, <sup>3</sup> represents the brake or keyway / oil seal type, <sup>4</sup> represents the shaft diameter and connector type, and <sup>5</sup> represents the special code.
2. Power supply for the brake is 24 V<sub>DC</sub>. Do not share the same power supply with control signals.
3. The brake coil has no polarity. Its pin symbols are BRAKE1 and BRAKE2. Color of brake cable for motors with the frame size of 100 mm or above: red and black.
4. When selecting the wires, refer to Section 3.1.6 for details.

Connector specifications:

UVW	Brand	Model name	IP rating
MIL 32-17S	Delta	ACS3-CRPWE000	IP42
	SUNCHU	CMS3108A32-17S (connector & compression ring)	IP42

Brake	Brand	Model name	IP rating	
CMV1-2S	Delta	ACS3-CRBRA000 (bayonet) ACS3-CRBRM000 (threaded)	IP67	
	DDK <sup>2</sup>	CMV1-AP2S-M1 (bayonet)	IP67	
	Suntone <sup>3</sup>		SM10-AP2S-M1-D6-V (bayonet)	IP67
			SM10H-AP2S-M1-D6-V (threaded)	

Note:

1. Refer to Section 3.1.7 for the diameter specification of the IP67- and IP42-compliant Delta connectors. For connector specification of other brands, contact the manufacturers.
2. The contacts, solder contacts (CMV1-#22BSC-S2-100) or crimp contacts (CMV1-#22BSC-C3-100), for the listed DDK connector are sold separately.
3. The contacts, solder contacts (SMS-5012 or SMS-5013) or crimp contacts (SMS-5011), for the listed Suntone connectors are sold separately.

### 3.1.5 Encoder cable and connector specifications

Select the appropriate connector according to the code of **Shaft diameter and connector type** in the motor model name. Refer to Section 1.2.2 for the model explanation of the servo motor.

#### 3.1.5.1 F40 - F80 motors – Encoder connectors

##### Encoder connection (Diagram 1): Standard connector

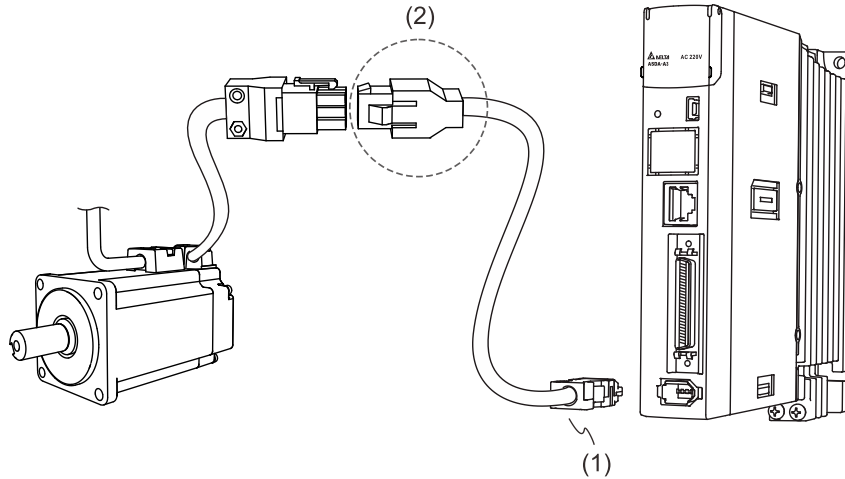

(1) CN2 connector; (2) Standard connector (female)

Note: the diagram shows the connection between the servo drive and the encoder, and it is not drawn to scale. The specification is subject to change depending on the selected servo drive and motor models.

Motor model	Standard connector (female)	
ECM-A3 <sup>1</sup> -C2040F <sup>3</sup> <sup>4</sup> <sup>5</sup>		
ECM-A3 <sup>1</sup> -C20401 <sup>3</sup> <sup>4</sup> <sup>5</sup>		
ECM-A3 <sup>1</sup> -C20602 <sup>3</sup> <sup>4</sup> <sup>5</sup>		
ECM-A3 <sup>1</sup> -C20604 <sup>3</sup> <sup>4</sup> <sup>5</sup>		
ECM-A3 <sup>1</sup> -C20804 <sup>3</sup> <sup>4</sup> <sup>5</sup>		
ECM-A3 <sup>1</sup> -C20807 <sup>3</sup> <sup>4</sup> <sup>5</sup>		
ECM-B3 <sup>1</sup> -C20401 <sup>3</sup> <sup>4</sup> <sup>5</sup>	Recommended brand	Model name
ECM-B3 <sup>1</sup> -C20602 <sup>3</sup> <sup>4</sup> <sup>5</sup>	Delta	ACS3-CAEN0000
ECM-B3 <sup>1</sup> -C20604 <sup>3</sup> <sup>4</sup> <sup>5</sup>	TE Connectivity	1-172161-9 or 172161-1 (case) 170359-1 (tin-plated terminal) 170359-3 (gold-plated terminal)
ECM-B3 <sup>1</sup> -C20804 <sup>3</sup> <sup>4</sup> <sup>5</sup>		
ECM-B3 <sup>1</sup> -C20807 <sup>3</sup> <sup>4</sup> <sup>5</sup>		
ECM-B3 <sup>1</sup> -C20810 <sup>3</sup> <sup>4</sup> <sup>5</sup>		

Note:

1. In the servo motor model name, <sup>1</sup> represents the motor inertia, <sup>2</sup> represents the encoder type, <sup>3</sup> represents the brake or keyway / oil seal type, <sup>4</sup> represents the shaft diameter and connector type, and <sup>5</sup> represents the special code.
2. We recommend using the connector with tin-plated terminals since the connector of the encoder cable from the servo motor side is also tin-plated.
3. When selecting the wires, refer to Section 3.1.6 for details.



3

**Specifications and pin assignment of the standard connector for the A3 / B3 incremental encoder**

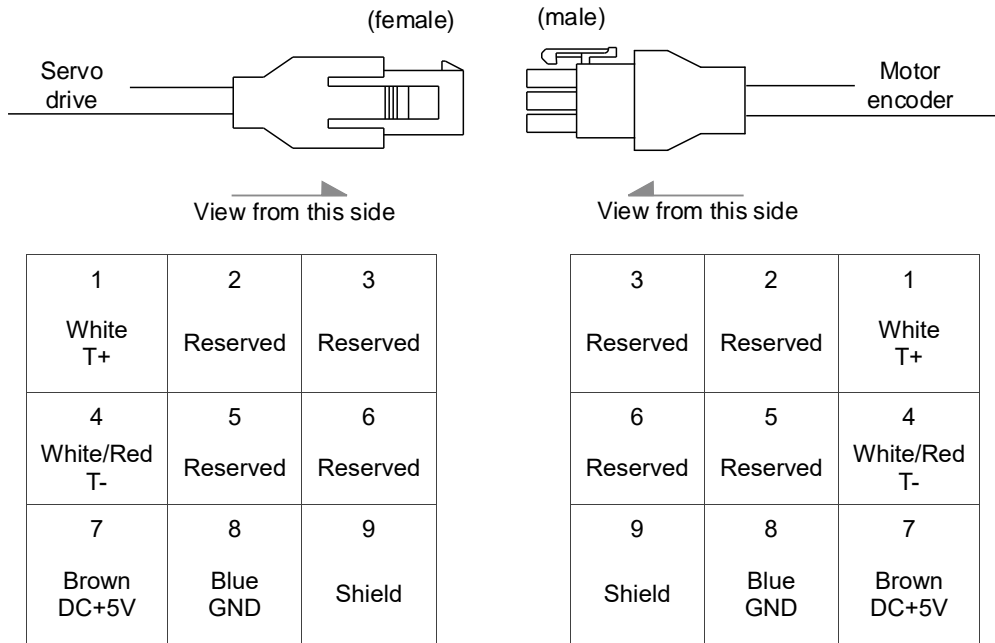

Note: the wire colors of the servo drive are for reference only. Refer to the actual servo drive.

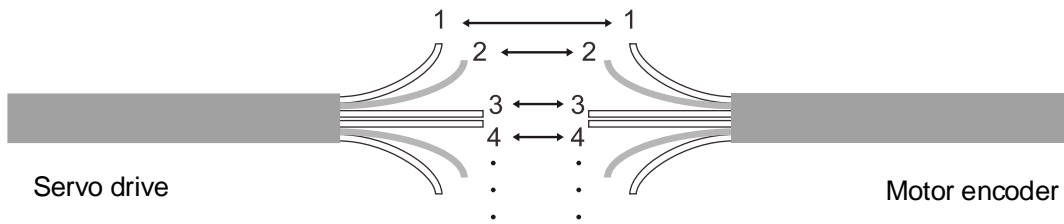

To directly connect the wires without using the connectors, number the wires of the servo drive encoder cable in sequence, and then connect them to the wires of the motor encoder cable. For example, connect wire No. 1 of the servo drive encoder cable to wire No. 1 of the motor encoder cable, and so on.

**Specifications and pin assignment of the standard connector for the A3 / B3 absolute encoder**

Connection method:

**Caution** Follow these instructions when wiring. Incorrect wiring may cause battery explosion.

3

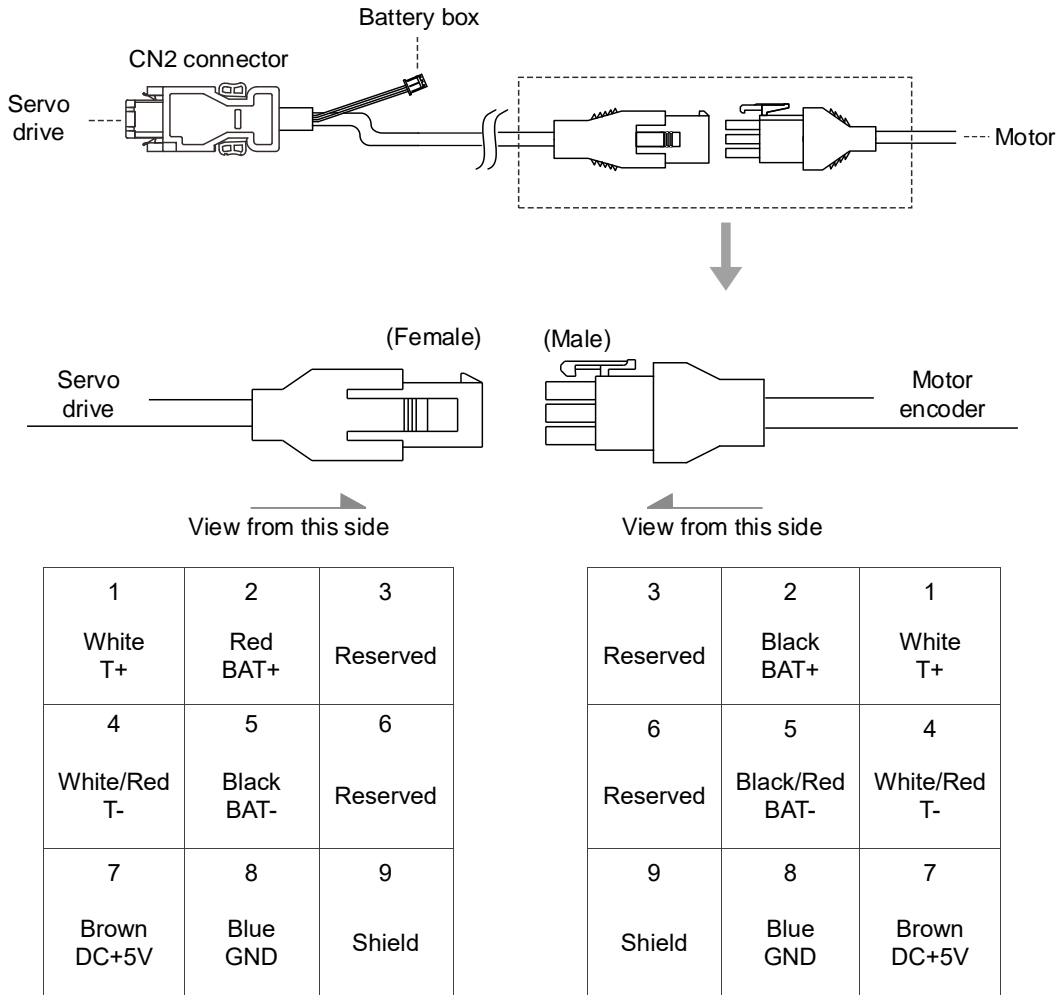

Note: the wire colors of the servo drive are for reference only. Refer to the actual servo drive.

**Encoder connection (Diagram 2): CHOGORI connectors for ECM-A3 / B3 motors**

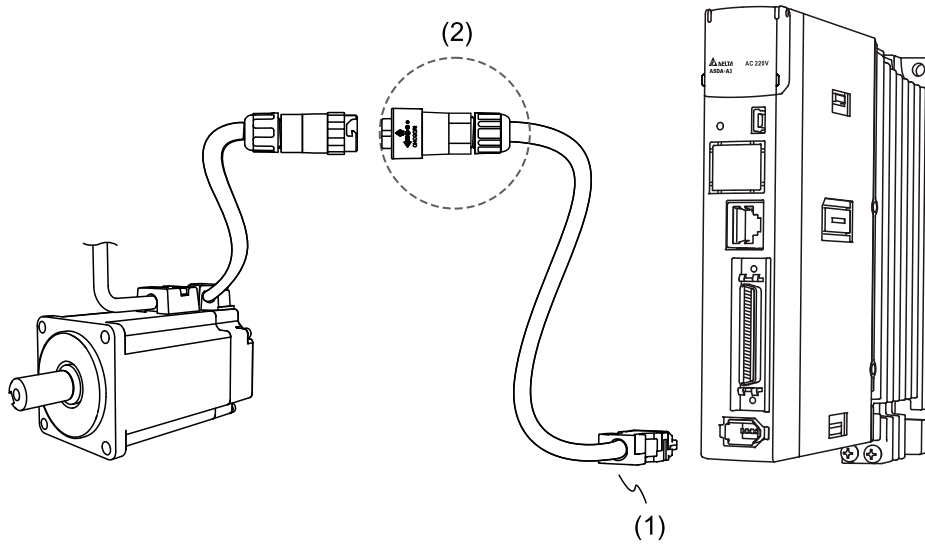

(1) CN2 connector; (2) CHOGORI connector

Note: the diagram shows the connection between the servo drive and the encoder, and it is not drawn to scale. The specification is subject to change depending on the selected servo drive and motor models.

Motor model	CHOGORI connector
ECM-A3 <sup>1</sup> -C <sup>2</sup> 040F <sup>3</sup> <sup>4</sup> <sup>5</sup>	
ECM-A3 <sup>1</sup> -C <sup>2</sup> 0401 <sup>3</sup> <sup>4</sup> <sup>5</sup>	
ECM-A3 <sup>1</sup> -C <sup>2</sup> 0602 <sup>3</sup> <sup>4</sup> <sup>5</sup>	
ECM-A3 <sup>1</sup> -C <sup>2</sup> 0604 <sup>3</sup> <sup>4</sup> <sup>5</sup>	
ECM-A3 <sup>1</sup> -C <sup>2</sup> 0804 <sup>3</sup> <sup>4</sup> <sup>5</sup>	
ECM-A3 <sup>1</sup> -C <sup>2</sup> 0807 <sup>3</sup> <sup>4</sup> <sup>5</sup>	
ECM-B3 <sup>1</sup> -C <sup>2</sup> 0401 <sup>3</sup> <sup>4</sup> <sup>5</sup>	
ECM-B3 <sup>1</sup> -C <sup>2</sup> 0602 <sup>3</sup> <sup>4</sup> <sup>5</sup>	
ECM-B3 <sup>1</sup> -C <sup>2</sup> 0604 <sup>3</sup> <sup>4</sup> <sup>5</sup>	
ECM-B3 <sup>1</sup> -C <sup>2</sup> 0804 <sup>3</sup> <sup>4</sup> <sup>5</sup>	
ECM-B3 <sup>1</sup> -C <sup>2</sup> 0807 <sup>3</sup> <sup>4</sup> <sup>5</sup>	
ECM-B3 <sup>1</sup> -C <sup>2</sup> 0810 <sup>3</sup> <sup>4</sup> <sup>5</sup>	

Note:

- In the servo motor model name, <sup>1</sup> represents the motor inertia, <sup>2</sup> represents the encoder type, <sup>3</sup> represents the brake or keyway / oil seal type, <sup>4</sup> represents the shaft diameter and connector type, and <sup>5</sup> represents the special code.
- When selecting the wires, refer to Section 3.1.6 for details.

**Connector specifications:**

A3 / B3 encoder	Brand	Model name	IP rating
IP67 waterproof connector	Delta	ACS3-CNEN2A00	IP67
	CHOGORI	22008231-01	IP67

Note: refer to Section 3.1.7 for the diameter specification of the IP67-compliant Delta connectors. For connector specification of other brands, contact the manufacturers.

**Specifications and pin assignment of the CHOGORI connector for the A3 / B3 incremental encoder**

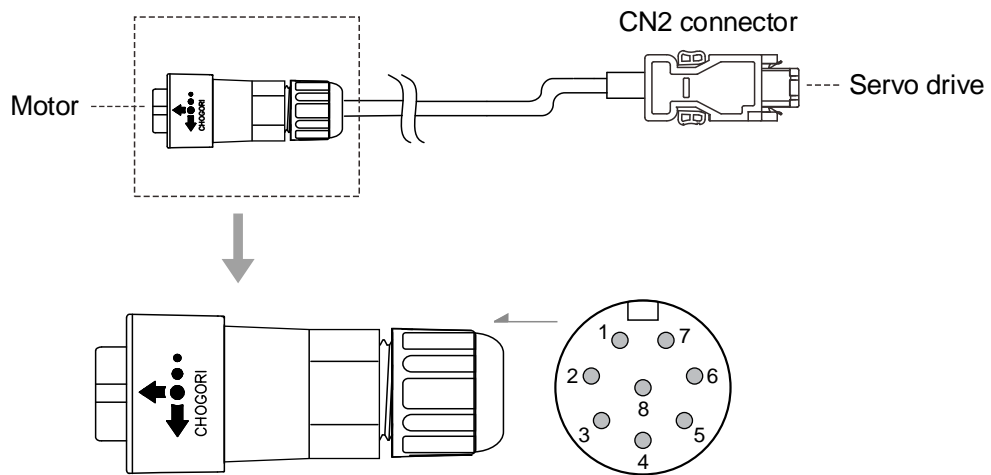

3

Pin No.	Terminal	Color
1	T+	White
2	T-	White/Red
3	GND	Blue
4	DC+5V	Brown
5, 6, 7	-	-
8	Shield	-

3

**Specifications and pin assignment of the CHOGORI connector for the A3 / B3 absolute encoder**

Connection method:

**Caution** Follow these instructions when wiring. Incorrect wiring may cause battery explosion.

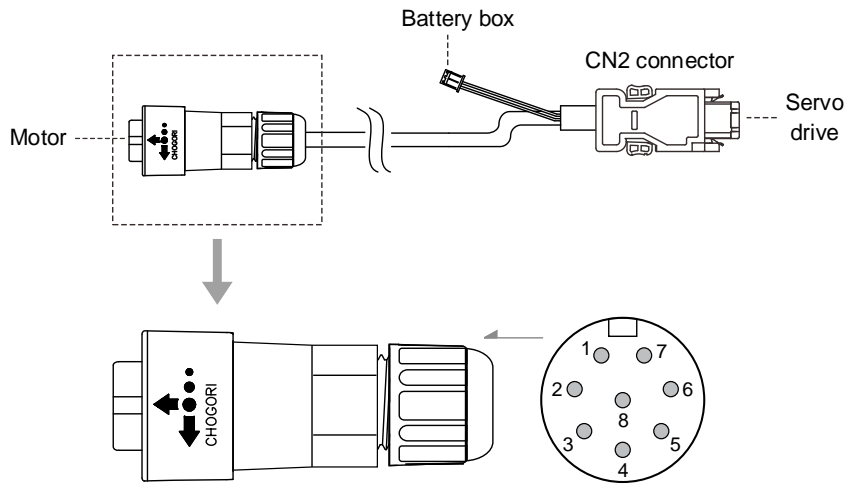

Pin No.	Terminal	Color
1	T+	White
2	T-	White/Red
3	GND	Blue
4	DC+5V	Brown
5	BAT-	Black
6	BAT+	Red
7	-	-
8	Shield	-

Note: if using an incremental encoder cable, connecting BAT+ and BAT- is not required.

**Encoder connection (Diagram 3): Bulkhead connector**

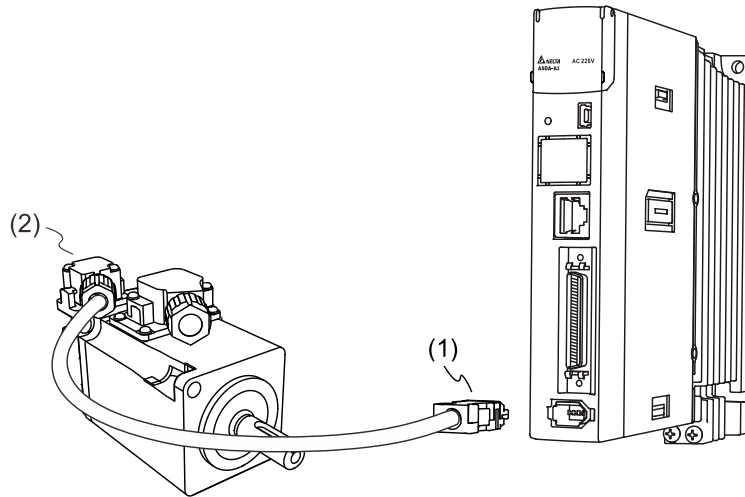

(1) CN2 connector; (2) Bulkhead connector (cable exit direction towards motor shaft)

Note: the diagram shows the connection between the servo drive and the encoder, and it is not drawn to scale. The specification is subject to change depending on the selected servo drive and motor models.

Motor model	Bulkhead connector		
ECM-B3 <sup>1</sup> -C <sup>2</sup> 0401 <sup>3</sup> <sup>4</sup> <sup>5</sup> ECM-B3 <sup>1</sup> -C <sup>2</sup> 0602 <sup>3</sup> <sup>4</sup> <sup>5</sup> ECM-B3 <sup>1</sup> -C <sup>2</sup> 0604 <sup>3</sup> <sup>4</sup> <sup>5</sup> ECM-B3 <sup>1</sup> -C <sup>2</sup> 0804 <sup>3</sup> <sup>4</sup> <sup>5</sup> ECM-B3 <sup>1</sup> -C <sup>2</sup> 0807 <sup>3</sup> <sup>4</sup> <sup>5</sup> ECM-B3 <sup>1</sup> -C <sup>2</sup> 0810 <sup>3</sup> <sup>4</sup> <sup>5</sup>	Cable exit direction towards motor shaft		
	Cable exit direction towards encoder		
	Brand	Model name	
	Delta	ACS3-AFEASA00	
	SUNCHU	SC-ACS3-AFEASA00	

Note:

1. In the servo motor model name, <sup>1</sup> represents the motor inertia, <sup>2</sup> represents the encoder type, <sup>3</sup> represents the brake or keyway / oil seal type, <sup>4</sup> represents the shaft diameter and connector type, and <sup>5</sup> represents the special code.
2. We recommend using the connector with gold-plated terminals since the connector of the encoder cable from the servo motor side is also gold-plated.
3. For the detailed pin assignment, refer to Section 3.5.

3.1.5.2 F100 - F180 ECMC motors – Encoder connectors

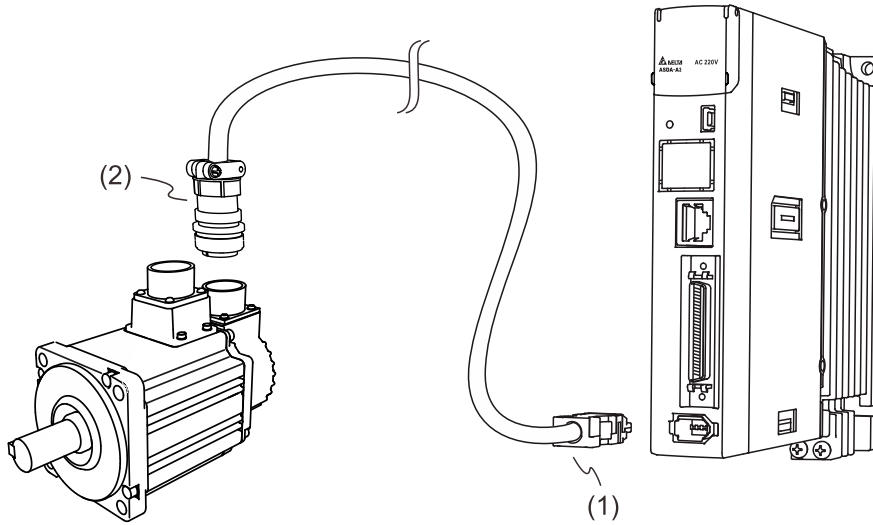

(1) CN2 connector; (2) Military connector

Note: the diagram shows the connection between the servo drive and the encoder, and it is not drawn to scale. The specification is subject to change depending on the selected servo drive and motor models.

Motor model	Military connector
ECMC-F <sup>2</sup> 1308 <sup>3</sup> 4	
ECMC-C <sup>2</sup> 1010 <sup>3</sup> 4	
ECMC-E <sup>2</sup> 1310 <sup>3</sup> 4	
ECMC-F <sup>2</sup> 1313 <sup>3</sup> 4	
ECMC-E <sup>2</sup> 1315 <sup>3</sup> 4	
ECMC-F <sup>2</sup> 1318 <sup>3</sup> 4	
ECMC-E <sup>2</sup> 1320 <sup>3</sup> 4	
ECMC-E <sup>2</sup> 1820 <sup>3</sup> 4	
ECMC-E <sup>2</sup> 1830 <sup>3</sup> 4	
ECMC-F <sup>2</sup> 1830 <sup>3</sup> 4	

Connector specifications:

ECMC encoder	Brand	Model name	IP rating
MIL 20-29S	SUNCHU	CMS3106A-20-29SBI (connector)	IP65
	PLT	WPS3106A-20-29S (connector) WPS3057-12A-R (cable clamp)	IP65

**Specifications and pin assignment of the military connector for the ECMC incremental encoder**

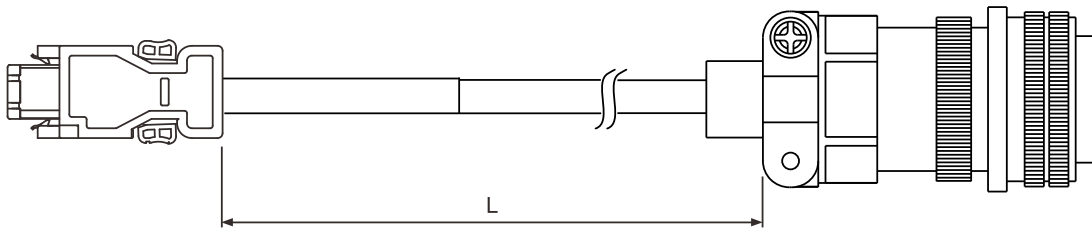

Model name	Connector	L	
		mm	inch
ACS3-CAE□3003	3106A-20-29S	3000 ± 50	118 ± 2
ACS3-CAE□3005	3106A-20-29S	5000 ± 50	197 ± 2
ACS3-CAE□3010	3106A-20-29S	10000 ± 100	394 ± 4
ACS3-CAE□3020	3106A-20-29S	20000 ± 100	787 ± 4

Note: select cables according to the □ in the model number. N represents standard cables and F represents flexible cables.

Connection method:

**Caution** Follow these instructions when wiring. Incorrect wiring may cause battery explosion.

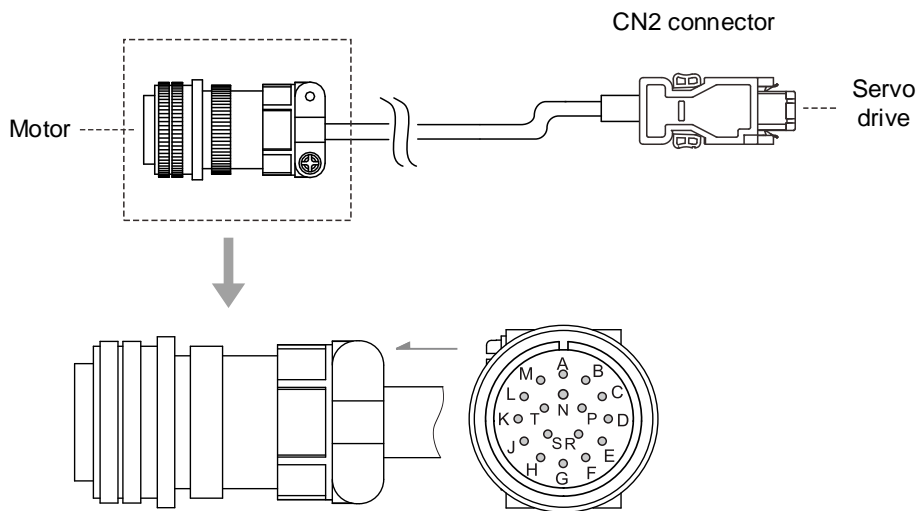

Pin No.	Terminal	Color
A	T+	White
B	T-	White/Red
S	DC+5V	Brown
R	GND	Blue
L	Shield	-
C, D, E, F, G, H, J, K, M, N, P, T	-	-



3

**Specifications and pin assignment of the military connector for the ECMC absolute encoder**

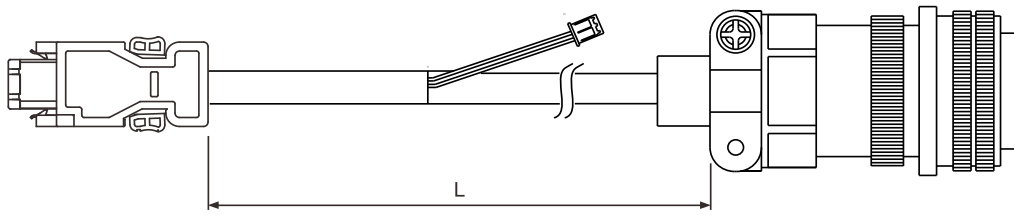

Model name	Connector	L	
		mm	inch
ACS3-CAE□3003	3106A-20-29S	3000 ± 50	118 ± 2
ACS3-CAE□3005	3106A-20-29S	5000 ± 50	197 ± 2
ACS3-CAE□3010	3106A-20-29S	10000 ± 100	394 ± 4
ACS3-CAE□3020	3106A-20-29S	20000 ± 100	787 ± 4

Note: select cables according to the □ in the model name. B represents flexible cables and A represents standard cables.

Connection method:

**Caution** Follow these instructions when wiring. Incorrect wiring may cause battery explosion.

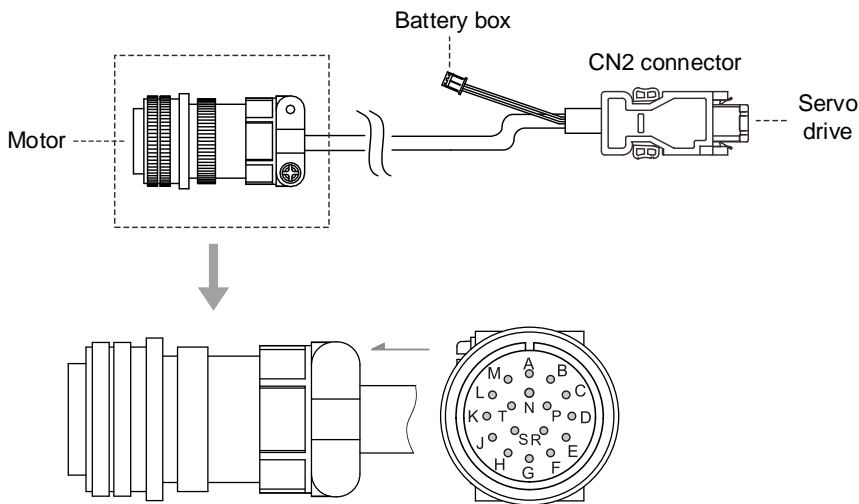

Pin No.	Terminal	Color
A	T+	White
B	T-	White/Red
C	BAT+	Red
D	BAT-	Black
S	DC+5V	Brown
R	GND	Blue
L	Shield	-
E, F, G, H, J, K, M, N, P, T	-	-

Note: if using an incremental encoder cable, connecting BAT+ and BAT- is not required.

3.1.5.3 F100 - F220 ECM-B3 motors – Encoder connectors

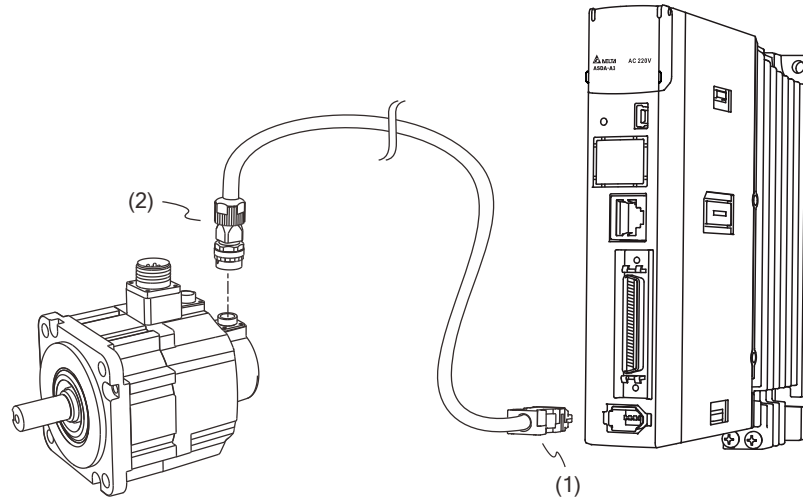

(1) CN2 connector; (2) Military connector

Note: the diagram shows the connection between the servo drive and the encoder, and it is not drawn to scale. The specification is subject to change depending on the selected servo drive and motor models.

Motor model	Military connector - straight
ECM-B3 <sup>1</sup> -C <sup>2</sup> 1010 <sup>3</sup> 4 <sup>4</sup> 5 <sup>5</sup>	
ECM-B3 <sup>1</sup> -C <sup>2</sup> 1015 <sup>3</sup> 4 <sup>4</sup> 5 <sup>5</sup>	
ECM-B3 <sup>1</sup> -C <sup>2</sup> 1020 <sup>3</sup> 4 <sup>4</sup> 5 <sup>5</sup>	
ECM-B3 <sup>1</sup> -E <sup>2</sup> 1310 <sup>3</sup> 4 <sup>4</sup> 5 <sup>5</sup>	
ECM-B3 <sup>1</sup> -E <sup>2</sup> 1315 <sup>3</sup> 4 <sup>4</sup> 5 <sup>5</sup>	
ECM-B3 <sup>1</sup> -E <sup>2</sup> 1320 <sup>3</sup> 4 <sup>4</sup> 5 <sup>5</sup>	
ECM-B3 <sup>1</sup> -F <sup>2</sup> 1308 <sup>3</sup> 4 <sup>4</sup> 5 <sup>5</sup>	
ECM-B3 <sup>1</sup> -F <sup>2</sup> 1313 <sup>3</sup> 4 <sup>4</sup> 5 <sup>5</sup>	
ECM-B3 <sup>1</sup> -F <sup>2</sup> 1318 <sup>3</sup> 4 <sup>4</sup> 5 <sup>5</sup>	
ECM-B3 <sup>1</sup> -E <sup>2</sup> 1820 <sup>3</sup> 4 <sup>4</sup> 5 <sup>5</sup>	
ECM-B3 <sup>1</sup> -F <sup>2</sup> 1830 <sup>3</sup> 4 <sup>4</sup> 5 <sup>5</sup>	
ECM-B3 <sup>1</sup> -F <sup>2</sup> 1845 <sup>3</sup> 4 <sup>4</sup> 5 <sup>5</sup>	
ECM-B3 <sup>1</sup> -F <sup>2</sup> 1855 <sup>3</sup> 4 <sup>4</sup> 5 <sup>5</sup>	
ECM-B3 <sup>1</sup> -F <sup>2</sup> 1875 <sup>3</sup> 4 <sup>4</sup> 5 <sup>5</sup>	
ECM-B3 <sup>1</sup> -F <sup>2</sup> 221B <sup>3</sup> 4 <sup>4</sup> 5 <sup>5</sup>	
ECM-B3 <sup>1</sup> -F <sup>2</sup> 221F <sup>3</sup> 4 <sup>4</sup> 5 <sup>5</sup>	

Note:

- In the servo motor model name, <sup>1</sup> represents the motor inertia, <sup>2</sup> represents the encoder type, <sup>3</sup> represents the brake or keyway / oil seal type, <sup>4</sup> represents the shaft diameter and connector type, and <sup>5</sup> represents the special code.
- When selecting the wires, refer to Section 3.1.6 for details.

Connector specifications:

B3 encoder	Brand	Model name	IP rating
	Delta	ACS3-CAENA000 (bayonet) ACS3-CAENM000 (threaded)	IP67
	DDK <sup>*2</sup>	CMV1-SP10S-M1 (bayonet)	IP67
CMV1-SP10S	Suntone <sup>*3</sup>	SM10-SP10S-M1-D6-V (bayonet) SM10H-SP10S-M1-D6-V (threaded)	IP67

Note:

- Refer to Section 3.1.7 for the diameter specification of the IP67-compliant Delta connectors. For connector specification of other brands, contact the manufacturers.
- The contacts, solder contacts (CMV1-#22ASC-S1-100) or crimp contacts (CMV1-#22ASC-C1-100), for the listed DDK connector are sold separately.
- The contacts, solder contacts (SMS-5012 or SMS-5013) or crimp contacts (SMS-5011), for the listed Suntone connectors are sold separately.

3

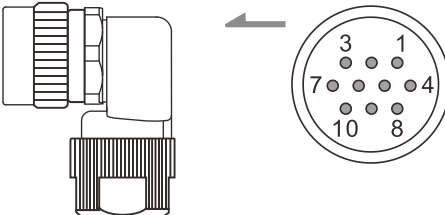
Motor model	Military connector - right angle
ECM-B3 <sup>1</sup> -C <sup>2</sup> 1010 <sup>3</sup> 4 <sup>5</sup>	
ECM-B3 <sup>1</sup> -C <sup>2</sup> 1015 <sup>3</sup> 4 <sup>5</sup>	
ECM-B3 <sup>1</sup> -C <sup>2</sup> 1020 <sup>3</sup> 4 <sup>5</sup>	
ECM-B3 <sup>1</sup> -E <sup>2</sup> 1310 <sup>3</sup> 4 <sup>5</sup>	
ECM-B3 <sup>1</sup> -E <sup>2</sup> 1315 <sup>3</sup> 4 <sup>5</sup>	
ECM-B3 <sup>1</sup> -E <sup>2</sup> 1320 <sup>3</sup> 4 <sup>5</sup>	
ECM-B3 <sup>1</sup> -F <sup>2</sup> 1308 <sup>3</sup> 4 <sup>5</sup>	
ECM-B3 <sup>1</sup> -F <sup>2</sup> 1313 <sup>3</sup> 4 <sup>5</sup>	
ECM-B3 <sup>1</sup> -F <sup>2</sup> 1318 <sup>3</sup> 4 <sup>5</sup>	
ECM-B3 <sup>1</sup> -E <sup>2</sup> 1820 <sup>3</sup> 4 <sup>5</sup>	
ECM-B3 <sup>1</sup> -F <sup>2</sup> 1830 <sup>3</sup> 4 <sup>5</sup>	
ECM-B3 <sup>1</sup> -F <sup>2</sup> 1845 <sup>3</sup> 4 <sup>5</sup>	
ECM-B3 <sup>1</sup> -F <sup>2</sup> 1855 <sup>3</sup> 4 <sup>5</sup>	
ECM-B3 <sup>1</sup> -F <sup>2</sup> 1875 <sup>3</sup> 4 <sup>5</sup>	
ECM-B3 <sup>1</sup> -F <sup>2</sup> 221B <sup>3</sup> 4 <sup>5</sup>	
ECM-B3 <sup>1</sup> -F <sup>2</sup> 221F <sup>3</sup> 4 <sup>5</sup>	

Note:

1. In the servo motor model name, <sup>1</sup> represents the motor inertia, <sup>2</sup> represents the encoder type, <sup>3</sup> represents the brake or keyway / oil seal type, <sup>4</sup> represents the shaft diameter and connector type, and <sup>5</sup> represents the special code.
2. When selecting the wires, refer to Section 3.1.6 for details.

Connector specifications:

B3 encoder	Brand	Model name	IP rating
CMV1-AP10S	Delta	ACS3-CRENA000 (bayonet) ACS3-CRENM000 (threaded)	IP67
	DDK <sup>*2</sup>	CMV1-AP10S-M1 (bayonet)	IP67
	Suntone <sup>*3</sup>	SM10-AP10S-M1-D6-V (bayonet) SM10H-AP10S-M1-D6-V (threaded)	IP67

Note:

1. Refer to Section 3.1.7 for the diameter specification of the IP67-compliant Delta connectors. For connector specification of other brands, contact the manufacturers.
2. The contacts, solder contacts (CMV1-#22ASC-S1-100) or crimp contacts (CMV1-#22ASC-C1-100), for the listed DDK connector are sold separately.
3. The contacts, solder contacts (SMS-5012 or SMS-5013) or crimp contacts (SMS-5011), for the listed Suntone connectors are sold separately.

### Specifications and pin assignment of the military connector (straight) for the B3 incremental encoder

Connection method:

**Caution** Follow these instructions when wiring. Incorrect wiring may cause battery explosion.

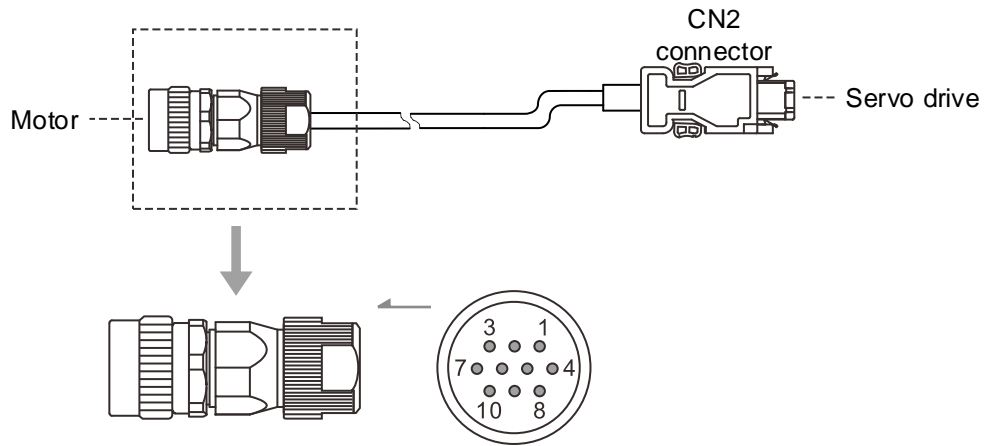

Pin No.	Terminal	Color
1	T+	White
2	T-	White/Red
3	-	-
4	DC+5V	Brown
5, 6, 7, 8	-	-
9	GND	Blue
10	Shield	-

# 3

## Specifications and pin assignment of the military connector (straight) for the B3 absolute encoder

Connection method:

**Caution** Follow these instructions when wiring. Incorrect wiring may cause battery explosion.

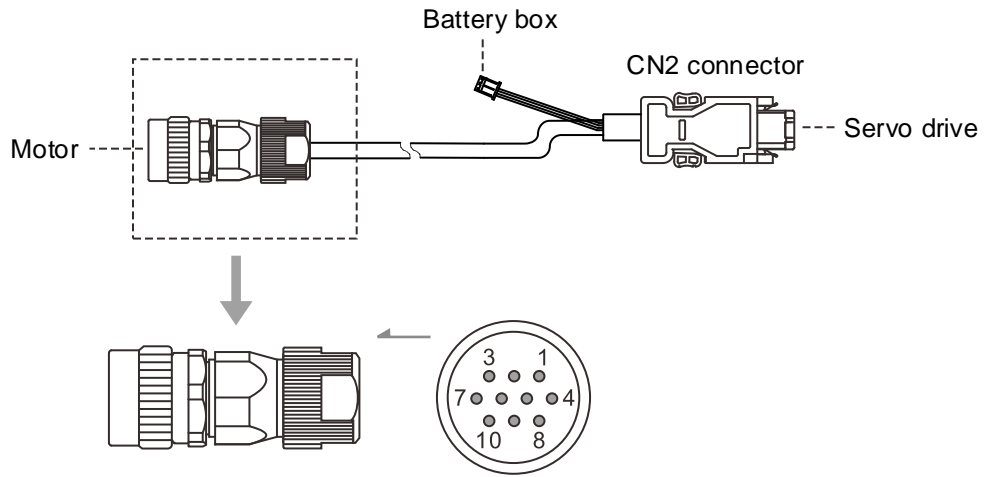

Pin No.	Terminal	Color
1	T+	White
2	T-	White/Red
3	-	-
4	DC+5V	Brown
5	BAT-	Black
6	BAT+	Red
7, 8	-	-
9	GND	Blue
10	Shield	-

### Specifications and pin assignment of the military connector (right angle) for the B3 incremental encoder

Connection method:

**Caution** Follow these instructions when wiring. Incorrect wiring may cause battery explosion.

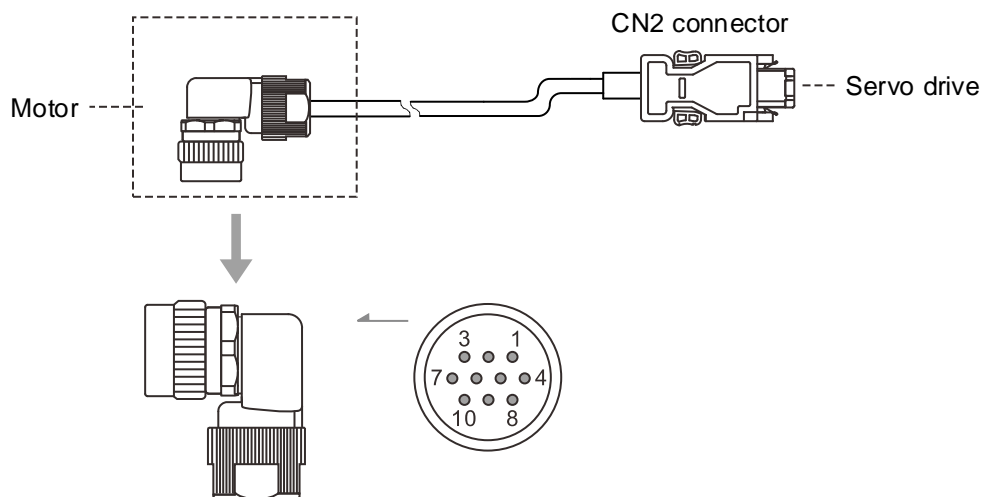

Pin No.	Terminal	Color
1	T+	White
2	T-	White/Red
3	-	-
4	DC+5V	Brown
5, 6, 7, 8	-	-
9	GND	Blue
10	Shield	-

3

**Specifications and pin assignment of the military connector (right angle) for the B3 absolute encoder**

Connection method:

**Caution** Follow these instructions when wiring. Incorrect wiring may cause battery explosion.

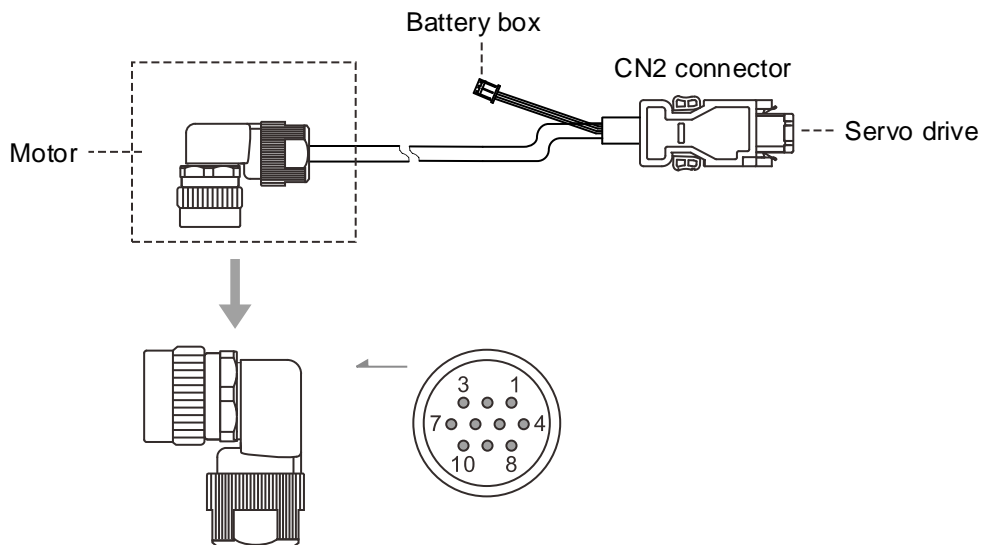

Pin No.	Terminal	Color
1	T+	White
2	T-	White/Red
3	-	-
4	DC+5V	Brown
5	BAT-	Black
6	BAT+	Red
7, 8	-	-
9	GND	Blue
10	Shield	-

### 3.1.6 Wire selection

#### 3.1.6.1 Wire diameters and terminals / ferrules

- For the terminal blocks on 3 kW (or below) models, use wire ferrules (end cord insulated terminals).
- For the screw terminal blocks on 4.5 kW (or above) models, use ring terminals.
- The suggested brand in the following table is K.S. Terminals Inc. Refer to Sections 3.1.6.2 and 3.1.6.3 for the suitable ferrule / terminal specifications.

Servo drive model	L <sub>1C</sub> , L <sub>2C</sub>		R, S, T, P <sub>1</sub> , P <sub>2</sub>		U, V, W		P <sub>3</sub> , D, C, ⊖	
	Wire diameter	Wire ferrule	Wire diameter <sup>Note 5</sup>	Wire ferrule	Wire diameter	Wire ferrule	Wire diameter	Wire ferrule
ASD-A3-0121-□	1.3 mm <sup>2</sup> (16 AWG)	E1512	0.21 mm <sup>2</sup> (24 AWG)	-	0.82 mm <sup>2</sup> (18 AWG)	E1012	2.1 mm <sup>2</sup> (14 AWG)	E2512
ASD-A3-0221-□	1.3 mm <sup>2</sup> (16 AWG)	E1512	0.32 mm <sup>2</sup> (22 AWG)	-	0.82 mm <sup>2</sup> (18 AWG)	E1012	2.1 mm <sup>2</sup> (14 AWG)	E2512
ASD-A3-0421-□	1.3 mm <sup>2</sup> (16 AWG)	E1512	0.52 mm <sup>2</sup> (20 AWG)	E0512	0.82 mm <sup>2</sup> (18 AWG)	E1012	2.1 mm <sup>2</sup> (14 AWG)	E2512
ASD-A3-0721-□	1.3 mm <sup>2</sup> (16 AWG)	E1512	1.3 mm <sup>2</sup> (16 AWG)	E1512	0.82 mm <sup>2</sup> (18 AWG) <sup>Note 6</sup>	E1012	2.1 mm <sup>2</sup> (14 AWG)	E2512
ASD-A3-1021-□	1.3 mm <sup>2</sup> (16 AWG)	E1512	2.1 mm <sup>2</sup> (14 AWG)	E2512	1.3 mm <sup>2</sup> (16 AWG) <sup>Note 6</sup>	E1512	2.1 mm <sup>2</sup> (14 AWG)	E2512
ASD-A3-1521-□	1.3 mm <sup>2</sup> (16 AWG)	E1512	2.1 mm <sup>2</sup> (14 AWG)	E2512	1.3 mm <sup>2</sup> (16 AWG) <sup>Note 6</sup>	E1512	2.1 mm <sup>2</sup> (14 AWG)	E2512
ASD-A3-2021-□	1.3 mm <sup>2</sup> (16 AWG)	E1512	2.1 mm <sup>2</sup> (14 AWG)	E2512	3.3 mm <sup>2</sup> (12 AWG)	E4012	2.1 mm <sup>2</sup> (14 AWG)	E2512
ASD-A3-3021-□	1.3 mm <sup>2</sup> (16 AWG)	E1512	2.1 mm <sup>2</sup> (14 AWG)	E2512	5.3 mm <sup>2</sup> (10 AWG)	E6012	2.1 mm <sup>2</sup> (14 AWG)	E2512

Servo drive model	L <sub>1C</sub> , L <sub>2C</sub>		R, S, T, P <sub>1</sub> , P <sub>2</sub>		U, V, W		P <sub>3</sub> , D, C, ⊖	
	Wire diameter	Ring terminal	Wire diameter	Ring terminal	Wire diameter	Ring terminal	Wire diameter	Ring terminal
ASD-A3-4523-□	1.3 mm <sup>2</sup> (16 AWG)	RVBL2-4	5.3 mm <sup>2</sup> (10 AWG)	RVBS5-4	8.4 mm <sup>2</sup> (8 AWG)	RVBS8-4	5.3 mm <sup>2</sup> (10 AWG)	RVBS8-4
ASD-A3-5523-□	1.3 mm <sup>2</sup> (16 AWG)	RVBL2-4	5.3 mm <sup>2</sup> (10 AWG)	RVBS5-4	8.4 mm <sup>2</sup> (8 AWG)	RVBS8-4	8.4 mm <sup>2</sup> (8 AWG)	RVBS8-4
ASD-A3-7523-□	1.3 mm <sup>2</sup> (16 AWG)	RVBL2-4	8.4 mm <sup>2</sup> (8 AWG)	RVBS8-4	13.3 mm <sup>2</sup> (6 AWG)	-	8.4 mm <sup>2</sup> (8 AWG)	RVBS8-4
ASD-A3-1B23-□	1.3 mm <sup>2</sup> (16 AWG)	RVBL2-4	13.3 mm <sup>2</sup> (6 AWG)	-	13.3 mm <sup>2</sup> (6 AWG)	-	13.3 mm <sup>2</sup> (6 AWG)	-
ASD-A3-1F23-□	1.3 mm <sup>2</sup> (16 AWG)	RVB2-7	21.2 mm <sup>2</sup> (4 AWG)	RVBS22-6	21.2 mm <sup>2</sup> (4 AWG)	RVBS22-6	21.2 mm <sup>2</sup> (4 AWG)	RVBS22-6

**Note:**

1. The shield should connect to the ground terminal ⊖.
2. When wiring, use the wires suggested in this section to avoid danger.
3. Choose the suitable terminals that comply with the wiring specifications. Use a crimping tool to properly crimp the terminals / ferrules and wires.
4. Do not use bare wires for wiring, or the loose wires may cause accidents.
5. The wire gauge of R, S, T for 100 W to 3 kW servo drives can be up to 14 AWG. Refer to Section 3.1.6.2 for the wire diameters specifications applicable to the wire ferrule.
6. When in a locked rotor condition, perform wiring according to the following specifications.

Model	Wire diameter	Wire ferrule
750 W	1.3 mm <sup>2</sup> (16 AWG)	E1512
1 kW 1.5 kW	2.1 mm <sup>2</sup> (14 AWG)	E2512



**Wire diameters for the attached terminals of Delta connectors**

The following table shows the Delta connectors with terminals attached and the applicable wire diameters. Refer to the actual product specification when wiring.

Connector	Applicable wire diameters for the attached terminals
ACS3-CAPW1000	AWG#24 - #18 (0.21 mm <sup>2</sup> - 0.82 mm <sup>2</sup> )
ACS3-CAPW2000	AWG#24 - #18 (0.21 mm <sup>2</sup> - 0.82 mm <sup>2</sup> )
ACS3-CAEN0000	AWG#26 - #22 (0.13 mm <sup>2</sup> - 0.32 mm <sup>2</sup> )
ACS3-AFPWSS00	UVW: AWG#20 - #18 (0.52 mm <sup>2</sup> - 0.82 mm <sup>2</sup> ) Brake: AWG#26 - #22 (0.13 mm <sup>2</sup> - 0.32 mm <sup>2</sup> )
ACS3-ABPWSS00	
ACS3-AFEASA00	AWG#26 - #22 (0.13 mm <sup>2</sup> - 0.32 mm <sup>2</sup> )

**3.1.6.2 Crimping the wire ferrules**

**100 W - 3 kW servo drives – Dimensions of wire ferrules**

Wire ferrules:

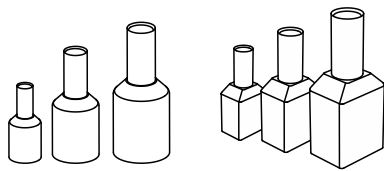

Recommended crimping tool  
(Delta part number: 3150165700):

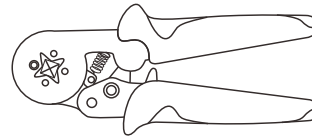

Dimensions of wire ferrules:

No doubling	
Doubling	

**100 W - 3 kW servo drives – Crimping for wire ferrules**

- Use a ferrule with the barrel length of **12 mm (0.47 inches)** and the wires of corresponding specifications for the drives. If the barrel length is shorter than 12 mm, the wire may fall off and cause danger.
- Use a ferrule crimper to properly crimp the barrel and wires.
- Do not use bare wires for wiring, or the loose wires may cause accidents.

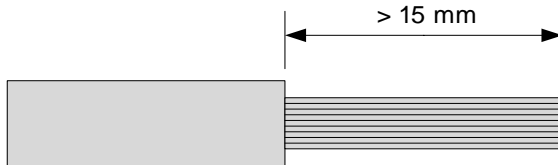

Step 1: cut through the insulation layer to expose the lead wire for more than 15 mm (0.59 inches).

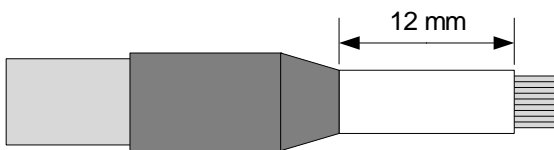

Step 2: insert the wire into the ferrule.

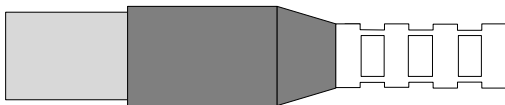

Step 3: use a ferrule crimper to crimp the barrel. Cut off the exposed lead wire; the remaining length of the exposed wire should be shorter than 0.5 mm (0.02 inches).

### 3.1.6.3 Screw terminal block dimensions / screw and tightening torque specifications

3

#### Screw terminal block dimensions

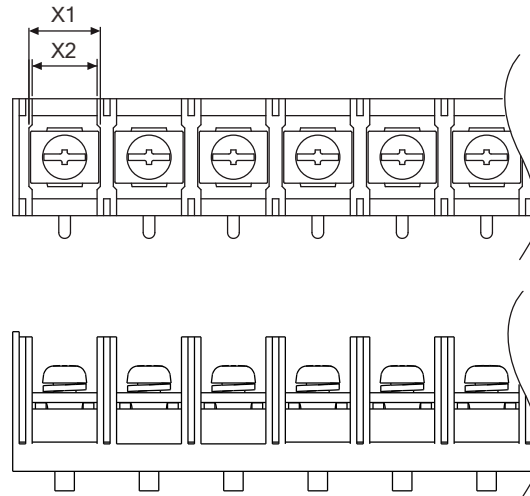

Servo drive	X1 mm (inch) / X2 mm (inch)				
	L <sub>1C</sub> , L <sub>2C</sub>	R, S, T	P1, P2	U, V, W	P3, D, C, ⊖
ASD-A3-4523- <span style="border: 1px solid black; padding: 0 2px;">2</span>	10 (0.39) / 11 (0.43)	10 (0.39) / 11 (0.43)	10 (0.39) / 11 (0.43)	10 (0.39) / 11 (0.43)	10 (0.39) / 11 (0.43)
ASD-A3-5523- <span style="border: 1px solid black; padding: 0 2px;">2</span>	10 (0.39) / 11 (0.43)	10 (0.39) / 11 (0.43)	10 (0.39) / 11 (0.43)	11 (0.43) / 12 (0.47)	10 (0.39) / 11 (0.43)
ASD-A3-7523- <span style="border: 1px solid black; padding: 0 2px;">2</span>	10 (0.39) / 11 (0.43)	10 (0.39) / 11 (0.43)	10 (0.39) / 11 (0.43)	11 (0.43) / 12 (0.47)	10 (0.39) / 11 (0.43)
ASD-A3-1B23- <span style="border: 1px solid black; padding: 0 2px;">2</span>	11 (0.43) / 12 (0.47)	11 (0.43) / 12 (0.47)	11 (0.43) / 12 (0.47)	12 (0.47) / 13 (0.51)	11 (0.43) / 12 (0.47)
ASD-A3-1F23- <span style="border: 1px solid black; padding: 0 2px;">2</span>	13 (0.51) / 14 (0.55)	13 (0.51) / 14 (0.55)	17 (0.67) / 18 (0.71)	17 (0.67) / 18 (0.71)	P3, C: 13 (0.51) / 14 (0.55) ⊖: 17 (0.67) / 18 (0.71)

Note: in the servo drive model name, 2 represents the model type.

#### Screw specification and tightening torque

Servo drive model	Screw specification and tightening torque (kgf-cm)									
	L <sub>1C</sub> , L <sub>2C</sub>		R, S, T, P1, P2		U, V, W		P3, D, C, ⊖		Ground screw ⊕	
ASD-A3-0121- <span style="border: 1px solid black; padding: 0 2px;">2</span> to ASD-A3-3023- <span style="border: 1px solid black; padding: 0 2px;">2</span>	-	-	-	-	-	-	-	-	-	-
ASD-A3-4523- <span style="border: 1px solid black; padding: 0 2px;">2</span>	M4	10	M4	10	M4	10	M4	10	M4	12 - 14
ASD-A3-5523- <span style="border: 1px solid black; padding: 0 2px;">2</span>										
ASD-A3-1B23- <span style="border: 1px solid black; padding: 0 2px;">2</span>					ASD-A3-1F23- <span style="border: 1px solid black; padding: 0 2px;">2</span>	M6				

Note: in the servo drive model name, 2 represents the model type.

Tightening torque (kgf-cm)	
CN1	CN5
2 - 2.5	

### 3.1.6.4 Encoder cable specifications

Item	Standard cable	Flexible cable
Model name	ACS3-CAEN01XX ACS3-CAEA01XX ACS3-CAEN11XX ACS3-CAEA11XX ACS3-CAENA1XX ACS3-CAEAA1XX ACS3-CRENA1XX ACS3-CREAA1XX	ACS3-CAEF01XX ACS3-CAEB01XX ACS3-CAEF11XX ACS3-CAEB11XX ACS3-CAEFA1XX ACS3-CAEBA1XX ACS3-CREFA1XX ACS3-CREBA1XX
Specification	UL2464 (Temp. rating: 80°C / 176°F)	UL2464 (Temp. rating: 80°C / 176°F)
DC+5V / GND	AWG#22-2C (0.32 mm <sup>2</sup> ) Outer diameter of insulated wire: $\Phi$ 1.3 mm	AWG#22-2C (0.32 mm <sup>2</sup> ) Outer diameter of insulated wire: $\Phi$ 1.3 mm
T+ / T-	AWG#24-2P (0.21 mm <sup>2</sup> ) Outer diameter of insulated wire: $\Phi$ 1.1 mm	AWG#24-2P (0.21 mm <sup>2</sup> ) Outer diameter of insulated wire: $\Phi$ 1.1 mm
Cable outer diameter	$\Phi$ 7 mm	
Max. wiring length	20 m	
Standard length provided by Delta	L = 3 m, 5 m, 10 m, 20 m	

Item	Standard cable	Flexible cable
Model name	ACS3-AFEASIXX ACS3-ABEASIXX ACS3-AFEASAXX ACS3-ABEASAXX	ACS3-AFERSIXX ACS3-ABERSIXX ACS3-AFERSAXX ACS3-ABERSAXX
Specification	UL20276 (Temp. rating: 80°C / 176°F)	UL20276 (Temp. rating: 80°C / 176°F)
DC+5V / GND	AWG#22-2C (0.32 mm <sup>2</sup> ) Outer diameter of insulated wire: $\Phi$ 1.3 mm	AWG#22-2C (0.32 mm <sup>2</sup> ) Outer diameter of insulated wire: $\Phi$ 1.3 mm
T+ / T-	AWG#26-2P (0.13 mm <sup>2</sup> ) Outer diameter of insulated wire: $\Phi$ 1.1 mm	AWG#26-2P (0.13 mm <sup>2</sup> ) Outer diameter of insulated wire: $\Phi$ 1.1 mm
Cable outer diameter	$\Phi$ 5.8 - $\Phi$ 6.2 mm	
Max. wiring length	20 m	
Standard length provided by Delta	L = 3 m, 5 m, 10 m, 20 m	

Note:

1. Use a shielded twisted-pair cable to reduce the noise interference.
2. The shield should connect to the  $\oplus$  phase of the ground terminal.
3. When wiring, use the wires suggested in this section to avoid danger.

### 3.1.6.5 Power cable specifications

#### Motor frame: F40 - F80

##### 220V series:

Item	Standard cable	Flexible cable
Model name	ACS3-CAPW11XX ACS3-CAPW21XX ACS3-CAPW51XX ACS3-CAPW61XX	ACS3-CAPF11XX ACS3-CAPF21XX ACS3-CAPF51XX ACS3-CAPF61XX
Specification	UL2586 (Temp. rating: 105°C / 221°F)	UL2586 (Temp. rating: 105°C / 221°F)
UVW wire	AWG#18-4C (0.82 mm <sup>2</sup> ) Outer diameter of insulated wire: $\Phi$ 2.1 mm Voltage rating: 600 V <sub>AC</sub>	AWG#18-4C (0.82 mm <sup>2</sup> ) Outer diameter of insulated wire: $\Phi$ 2.1 mm Voltage rating: 600 V <sub>AC</sub>
Brake wire	AWG#22-2C (0.32 mm <sup>2</sup> ) Outer diameter of insulated wire: $\Phi$ 1.6 mm Voltage rating: 600 V <sub>AC</sub>	AWG#22-2C (0.32 mm <sup>2</sup> ) Outer diameter of insulated wire: $\Phi$ 1.6 mm Voltage rating: 600 V <sub>AC</sub>
Cable outer diameter	Power cable w/o brake: $\Phi$ 7.7 mm; power cable with brake: $\Phi$ 8.6 mm	
Max. wiring length	20 m	
Standard length provided by Delta	L = 3 m, 5 m, 10 m, 20 m	

Item	Standard cable	Flexible cable
Model name	ACS3-AFPWSRXX ACS3-AFPWSSXX	ACS3-AFPRSRXX ACS3-AFPRSSXX
Specification	UL2517 (Temp. rating: 105°C / 221°F)	UL2517 (Temp. rating: 105°C / 221°F)
UVW wire	AWG#20-4C (0.52 mm <sup>2</sup> ) Outer diameter of insulated wire: $\Phi$ 1.8 mm Voltage rating: 300 V <sub>AC</sub>	AWG#20-4C (0.52 mm <sup>2</sup> ) Outer diameter of insulated wire: $\Phi$ 1.8 mm Voltage rating: 300 V <sub>AC</sub>
Brake wire	AWG#24-2C (0.21 mm <sup>2</sup> ) Outer diameter of insulated wire: $\Phi$ 1.2 mm Voltage rating: 300 V <sub>AC</sub>	AWG#24-2C (0.21 mm <sup>2</sup> ) Outer diameter of insulated wire: $\Phi$ 1.2 mm Voltage rating: 300 V <sub>AC</sub>
Cable outer diameter	$\Phi$ 6.0 - $\Phi$ 6.8 mm	
Max. wiring length	20 m	
Standard length provided by Delta	L = 3 m 、 5 m 、 10 m 、 20 m	

##### Note:

- For detailed specifications of wire diameters and terminals / ferrules, refer to Section 3.1.6.1.
- Apart from the specifications mentioned above, refer to Section 2.7.1 for the motor cable selection and installation precautions.

**400V series:**

Item	Standard cable	Flexible cable
Model name	ACS3-CAPW21XX ACS3-CAPW31XX	ACS3-CAPF21XX ACS3-CAPF31XX
Specification	UL2586 (Temp. rating: 105°C / 221°F)	UL2586 (Temp. rating: 105°C / 221°F)
UVW wire	AWG#18-4C (0.82 mm <sup>2</sup> ) Outer diameter of insulated wire: $\Phi$ 2.1 mm Voltage rating: 600 V <sub>AC</sub>	AWG#18-4C (0.82 mm <sup>2</sup> ) Outer diameter of insulated wire: $\Phi$ 2.1 mm Voltage rating: 600 V <sub>AC</sub>
Brake wire	AWG#22-2C (0.32 mm <sup>2</sup> ) Outer diameter of insulated wire: $\Phi$ 1.6 mm Voltage rating: 600 V <sub>AC</sub>	AWG#22-2C (0.32 mm <sup>2</sup> ) Outer diameter of insulated wire: $\Phi$ 1.6 mm Voltage rating: 600 V <sub>AC</sub>
Cable outer diameter	Power cable w/o brake: $\Phi$ 7.7 mm; power cable with brake: $\Phi$ 8.6 mm	
Max. wiring length	20 m	
Standard length provided by Delta	L = 3 m, 5 m, 10 m, 20 m	

**Note:**

- For detailed specifications of wire diameters and terminals / ferrules, refer to Section 3.2.6.1.
- Apart from the specifications mentioned above, refer to Section 2.7.1 for the motor cable selection and installation precautions.

**Motor frame: F100 - F130**

Item	Standard cable	Flexible cable
Power cable	Model name	ACS3-CAPWA2XX ACS3-CRPWA2XX
	Specification	UL2586 (Temp. rating: 105°C / 221°F) AWG#16-4C (1.3 mm <sup>2</sup> ) Outer diameter of insulated wire: $\Phi$ 3.2 mm Cable diameter: $\Phi$ 11 mm Voltage rating: 600 V <sub>AC</sub>
	Model name	ACS3-CAPWA3XX ACS3-CRPWA3XX
	Specification	UL2586 (Temp. rating: 105°C / 221°F) AWG#14-4C (2.1 mm <sup>2</sup> ) Outer diameter of insulated wire: $\Phi$ 2.8 mm Cable diameter: $\Phi$ 9.5 mm Voltage rating: 600 V <sub>AC</sub>
Brake cable	Model name	ACS3-CABRA1XX ACS3-CRBRA1XX
	Specification	UL2517 (Temp. rating: 105°C / 221°F) AWG#20-2C (0.52 mm <sup>2</sup> ) Outer diameter of insulated wire: $\Phi$ 1.8 mm Cable diameter: $\Phi$ 5.5 mm Voltage rating: 300 V <sub>AC</sub>
Max. wiring length	20 m	
Standard length provided by Delta	L = 3 m, 5 m, 10 m, 20 m	

**Note:**

- For detailed specifications of wire diameters and terminals / ferrules, refer to Sections 3.1.6.1 and 3.2.6.1.
- Apart from the specifications mentioned above, refer to Section 2.7.1 for the motor cable selection and installation precautions.

**Motor frame and power: F180 4.5 kW (or below)**

Item	Standard cable	Flexible cable	
Power cable	Model name	ACS3-CAPWC3XX ACS3-CRPWC3XX	ACS3-CAPFC3XX ACS3-CRPFC3XX
	Specification	UL2586 (Temp. rating: 105°C / 221°F) AWG#14-4C (2.1 mm <sup>2</sup> ) Outer diameter of insulated wire: $\Phi$ 2.8 mm Cable diameter: $\Phi$ 9.5 mm Voltage rating: 600 V <sub>AC</sub>	UL2586 (Temp. rating: 105°C / 221°F) AWG#14-4C (2.1 mm <sup>2</sup> ) Outer diameter of insulated wire: $\Phi$ 2.8 mm Cable diameter: $\Phi$ 9.5 mm Voltage rating: 600 V <sub>AC</sub>
	Model name	ACS3-CAPWC4XX ACS3-CRPWC4XX	ACS3-CAPFC4XX ACS3-CRPFC4XX
	Specification	UL2586 (Temp. rating: 105°C / 221°F) AWG#12-4C (3.3 mm <sup>2</sup> ) Outer diameter of insulated wire: $\Phi$ 4.0 mm Cable diameter: $\Phi$ 14.5 mm Voltage rating: 600 V <sub>AC</sub>	UL2586 (Temp. rating: 105°C / 221°F) AWG#12-4C (3.3 mm <sup>2</sup> ) Outer diameter of insulated wire: $\Phi$ 4.0 mm Cable diameter: $\Phi$ 14.5 mm Voltage rating: 600 V <sub>AC</sub>
	Model name	ACS3-CAPWC5XX ACS3-CRPWC5XX	ACS3-CAPFC5XX ACS3-CRPFC5XX
	Specification	UL2586 (Temp. rating: 105°C / 221°F) AWG#10-4C (5.3 mm <sup>2</sup> ) Outer diameter of insulated wire: $\Phi$ 4.6 mm Cable diameter: $\Phi$ 15 mm Voltage rating: 600 V <sub>AC</sub>	UL2586 (Temp. rating: 105°C / 221°F) AWG#10-4C (5.3 mm <sup>2</sup> ) Outer diameter of insulated wire: $\Phi$ 4.6 mm Cable diameter: $\Phi$ 15 mm Voltage rating: 600 V <sub>AC</sub>
	Model name	ACS3-CAPWC6XX ACS3-CRPWC6XX	ACS3-CAPFC6XX ACS3-CRPFC6XX
	Specification	UL2586 (Temp. rating: 105°C / 221°F) AWG#8-4C (8.4 mm <sup>2</sup> ) Outer diameter of insulated wire: $\Phi$ 7.0 mm Cable diameter: $\Phi$ 22 mm Voltage rating: 600 V <sub>AC</sub>	UL2586 (Temp. rating: 105°C / 221°F) AWG#8-4C (8.4 mm <sup>2</sup> ) Outer diameter of insulated wire: $\Phi$ 7.0 mm Cable diameter: $\Phi$ 22 mm Voltage rating: 600 V <sub>AC</sub>
Brake cable	Model name	ACS3-CABRA1XX ACS3-CRBRA1XX	ACS3-CABFA1XX ACS3-CRBFA1XX
	Specification	UL2517 (Temp. rating: 105°C / 221°F) AWG#20-2C (0.52 mm <sup>2</sup> ) Outer diameter of insulated wire: $\Phi$ 1.8 mm Cable diameter: $\Phi$ 5.5 mm Voltage rating: 300 V <sub>AC</sub>	UL2517 (Temp. rating: 105°C / 221°F) AWG#20-2C (0.52 mm <sup>2</sup> ) Outer diameter of insulated wire: $\Phi$ 1.8 mm Cable diameter: $\Phi$ 5.5 mm Voltage rating: 300 V <sub>AC</sub>
Max. wiring length		20 m	
Standard length provided by Delta		L = 3 m, 5 m, 10 m, 20 m	

## Note:

- For detailed specifications of wire diameters and terminals / ferrules, refer to Sections 3.1.6.1 and 3.2.6.1.
- Apart from the specifications mentioned above, refer to Section 2.7.1 for the motor cable selection and installation precautions.

**Motor frame and power: F180 5.5 kW (or above) & F220**

Item		Standard cable	Flexible cable
Power cable	Model name	ACS3-CAPWE6XX ACS3-CRPWE6XX	ACS3-CAPFE6XX ACS3-CRPFE6XX
	Specification	UL2586 (Temp. rating: 105°C / 221°F) AWG#8-4C (8.4 mm <sup>2</sup> ) Outer diameter of insulated wire: $\Phi$ 7.0 mm Cable diameter: $\Phi$ 22 mm Voltage rating: 600 V <sub>AC</sub>	UL2586 (Temp. rating: 105°C / 221°F) AWG#8-4C (8.4 mm <sup>2</sup> ) Outer diameter of insulated wire: $\Phi$ 7.0 mm Cable diameter: $\Phi$ 22 mm Voltage rating: 600 V <sub>AC</sub>
	Model name	ACS3-CAPWE7XX ACS3-CRPWE7XX	ACS3-CAPFE7XX ACS3-CRPFE7XX
	Specification	UL2586 (Temp. rating: 105°C / 221°F) AWG#6-4C (13.3 mm <sup>2</sup> ) Outer diameter of insulated wire: $\Phi$ 8.8 mm Cable diameter: $\Phi$ 28 mm Voltage rating: 600 V <sub>AC</sub>	UL2586 (Temp. rating: 105°C / 221°F) AWG#6-4C (13.3 mm <sup>2</sup> ) Outer diameter of insulated wire: $\Phi$ 8.8 mm Cable diameter: $\Phi$ 28 mm Voltage rating: 600 V <sub>AC</sub>
	Model name	ACS3-CAPWE8XX ACS3-CRPWE8XX	ACS3-CAPFE8XX ACS3-CRPFE8XX
	Specification	UL2586 (Temp. rating: 105°C / 221°F) AWG#4-4C (21.2 mm <sup>2</sup> ) Outer diameter of insulated wire: $\Phi$ 10.2 mm Cable diameter: $\Phi$ 32 mm Voltage rating: 600 V <sub>AC</sub>	UL2586 (Temp. rating: 105°C / 221°F) AWG#4-4C (21.2 mm <sup>2</sup> ) Outer diameter of insulated wire: $\Phi$ 10.2 mm Cable diameter: $\Phi$ 32 mm Voltage rating: 600 V <sub>AC</sub>
Brake cable	Model name	ACS3-CABRA1XX ACS3-CRBRA1XX	ACS3-CABFA1XX ACS3-CRBFA1XX
	Specification	UL2517 (Temp. rating: 105°C / 221°F) AWG#20-2C (0.52 mm <sup>2</sup> ) Outer diameter of insulated wire: $\Phi$ 1.8 mm Cable diameter: $\Phi$ 5.5 mm Voltage rating: 300 V <sub>AC</sub>	UL2517 (Temp. rating: 105°C / 221°F) AWG#20-2C (0.52 mm <sup>2</sup> ) Outer diameter of insulated wire: $\Phi$ 1.8 mm Cable diameter: $\Phi$ 5.5 mm Voltage rating: 300 V <sub>AC</sub>
Max. wiring length		20 m	
Standard length provided by Delta		L = 3 m, 5 m, 10 m, 20 m	

## Note:

- For detailed specifications of wire diameters and terminals / ferrules, refer to Sections 3.1.6.1 and 3.2.6.1.
- Apart from the specifications mentioned above, refer to Section 2.7.1 for the motor cable selection and installation precautions.



## 3

### 3.1.6.6 Flexible cable specifications

Delta provides two types of power and encoder cables: standard cables and flexible cables. Use flexible cable when connecting to a moving machinery. Refer to the following table for flexible cable specifications.

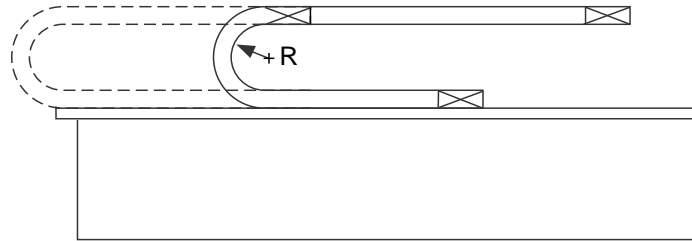

R = bend radius of the cable

Item	Specification
Bend radius	10 times of the cable outer diameter
Number of bending times	10 million times* <sup>1</sup>
Bending speed	3 m/s
Acceleration	15 m/s <sup>2</sup>

Note:

1. Bending the cable into a curve and then straightening it is considered as one time.
2. For precautions relevant to the use of cables, refer to Section 2.10.

### 3.1.7 Waterproof connector wiring instructions

#### 3.1.7.1 F40 - F80 models – power / encoder / brake connector

##### CHOGORI connector

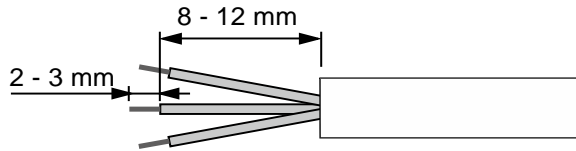

**Step 1:**

Cut through the cable and expose the shielding. The exposed wire length should be 8 - 12 mm (0.31 - 0.47 inches) and the tinned wire length should be 2 - 3 mm (0.08 - 0.12 inches).

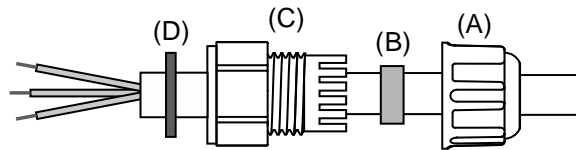

**Step 2:**

Place the (A) seals nut, (B) seals ring, (C) clamp ring, and (D) gasket on the cable in sequence.

Note: place the flat face of the gasket outwards and the groove face towards the clamp ring for the IP67 design.

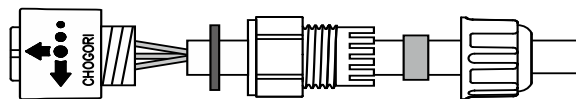

**Step 3:**

- For the power connector, refer to Section 3.1.4 for the pin assignment to connect the pins.
- For the encoder connector, refer to Section 3.1.5 for the pin assignment to connect the pins.

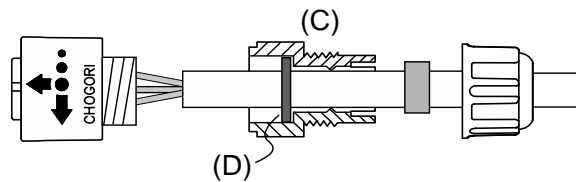

**Step 4:**

Place the groove face of the (D) gasket towards the clamp ring and fit it into the (C) clamp ring.

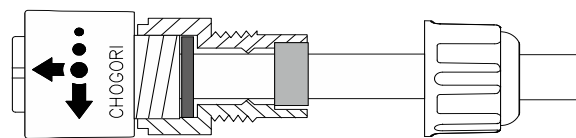

**Step 5:**

Use a wrench to lock the clamp ring to the housing and **place** the seals ring **in** the clamp ring.

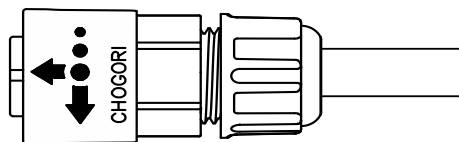

**Step 6:**

Use a wrench to lock the seals nut to the clamp ring to complete the wiring.

Instruction on mating and unmating the CHOGORI connectors:

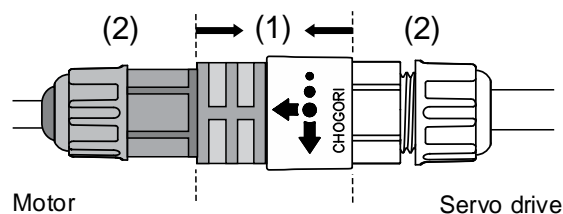

After wiring the CHOGORI connector, mate the part (1) to connect the servo motor and drive. Do not pull or rotate the (2) clamp ring and seals nut to avoid loose connection and thus fail to meet the IP67 standard.

# 3

## Bulkhead connector

The example here uses the bulkhead connector with the **cable exit direction towards motor shaft:**  
**shaft:**

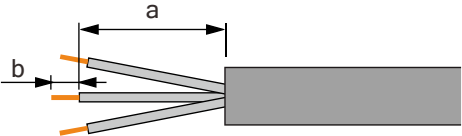
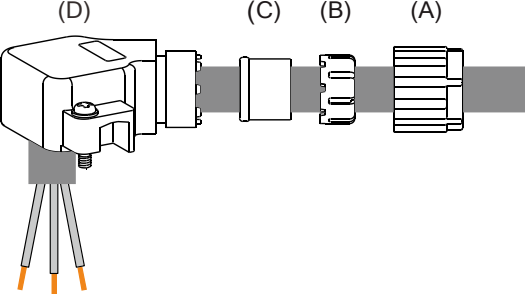
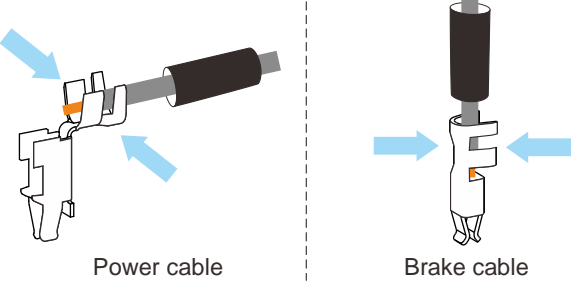
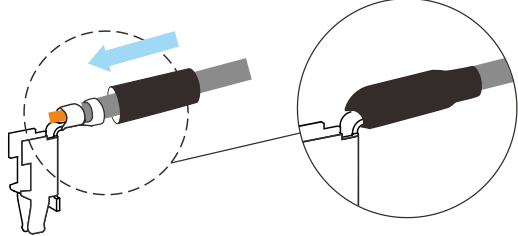
 <p>The diagram shows a cable with a grey jacket and several internal wires. Dimension 'a' is the length of the jacket that is cut away. Dimension 'b' is the length of the exposed wires.</p>	<p><b>Step 1:</b></p> <p>Cut through the cable and expose the shielding. The exposed wire length (a) should be 15 mm (0.59 inches) and the tinned wire length (b) should be as follows:</p> <ul style="list-style-type: none"> <li>■ For encoder cables / brake cables: 1.5 - 1.8 mm (0.059 - 0.071 inches)</li> <li>■ For power cables of bulkhead connectors (cable exit direction towards motor shaft): 2 - 2.2 mm (0.079 - 0.087 inches)</li> <li>■ For power cables of bulkhead connectors (cable exit direction towards encoder): 1.8 - 2 mm (0.071 - 0.079 inches)</li> </ul>
 <p>The diagram shows four components labeled (A) through (D) being assembled onto the cable. (A) is a seals nut, (B) is a compression ring, (C) is a rubber ring, and (D) is the housing.</p>	<p><b>Step 2:</b></p> <p>Place the (A) seals nut, (B) compression ring, (C) rubber ring (with the bulge side towards the housing), and (D) housing on the cable in sequence.</p> <p>Note: use the rubber ring corresponding to the cable in order to meet the IP67 standard.</p>
 <p>The diagram shows two crimping processes. On the left, a 'Power cable' is crimped. On the right, a 'Brake cable' is crimped. Blue arrows indicate the direction of force applied during crimping.</p>	<p><b>Step 3:</b></p> <p>Slide the heat shrink onto the cable, and then crimp the terminal.</p>
 <p>The diagram shows heat shrink tubing being applied to the cable. A dashed circle indicates the area where the tubing is being applied. A circular inset shows a close-up of the tubing being applied to the cable.</p>	<p><b>Step 4:</b></p> <p>Shrink the tubing at a distance of 1 mm (0.039 inches) away from the terminal.</p> <p>Specifications of heat shrink:</p> <ul style="list-style-type: none"> <li>■ For power cables: 5 mm (0.2 inches)</li> <li>■ For brake cables: 10 mm (0.39 inches)</li> <li>■ For shielded cables: 18 mm (0.71 inches)</li> </ul> <p>Note: heat shrink is not required for the encoder signal cable.</p>

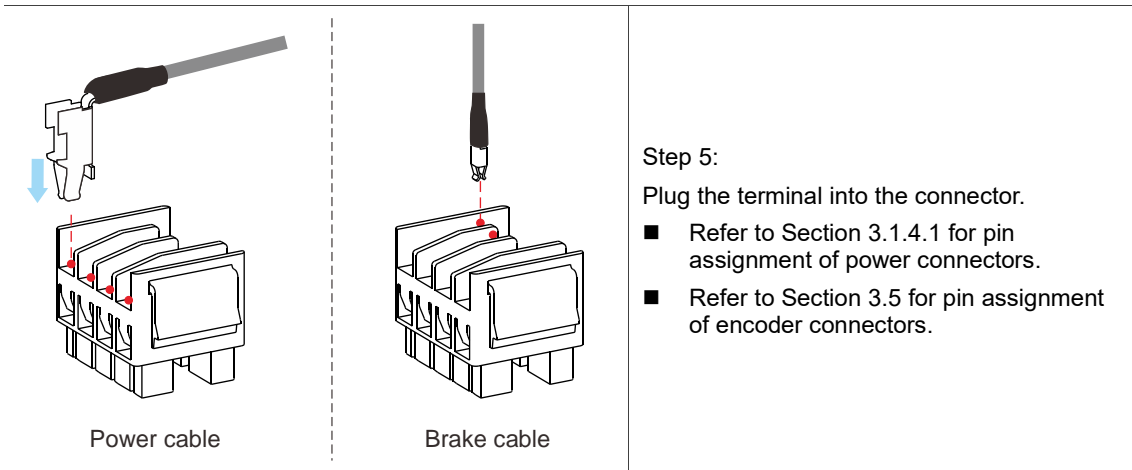

Step 5:

Plug the terminal into the connector.

- Refer to Section 3.1.4.1 for pin assignment of power connectors.
- Refer to Section 3.5 for pin assignment of encoder connectors.

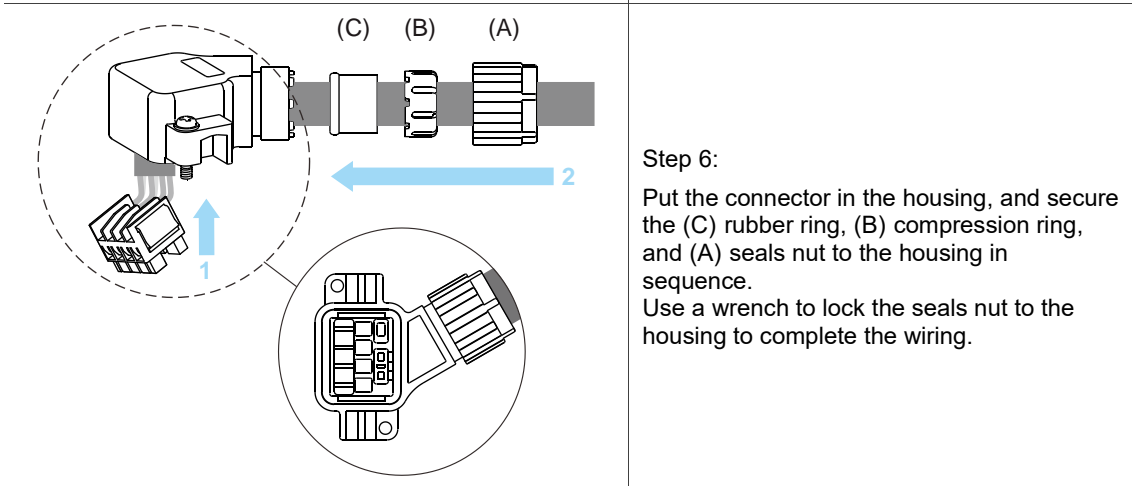

Step 6:

Put the connector in the housing, and secure the (C) rubber ring, (B) compression ring, and (A) seals nut to the housing in sequence.

Use a wrench to lock the seals nut to the housing to complete the wiring.

Note the following:

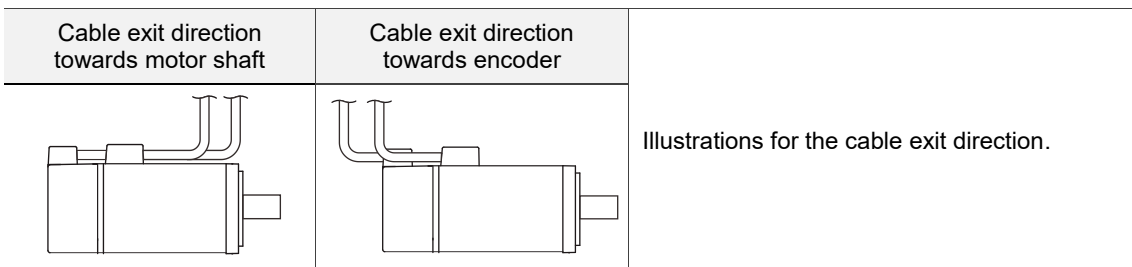

Illustrations for the cable exit direction.

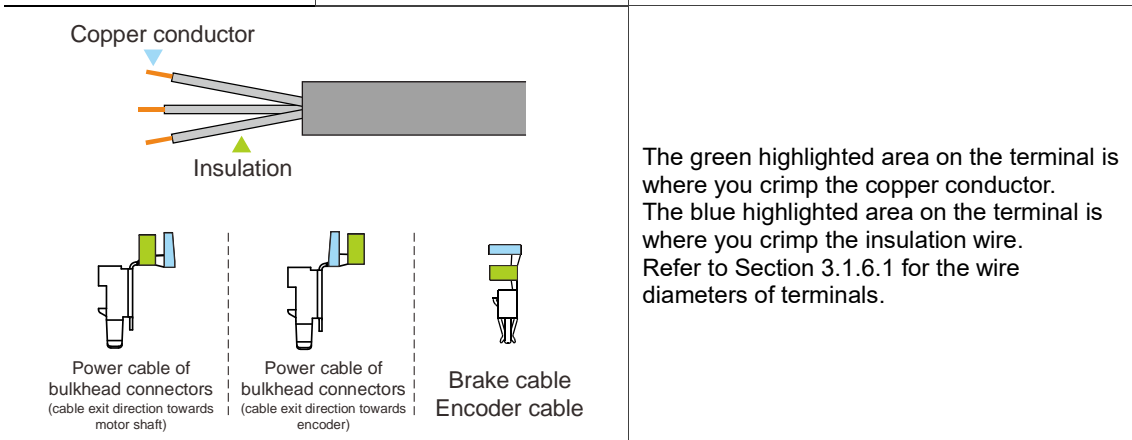

The green highlighted area on the terminal is where you crimp the copper conductor. The blue highlighted area on the terminal is where you crimp the insulation wire. Refer to Section 3.1.6.1 for the wire diameters of terminals.

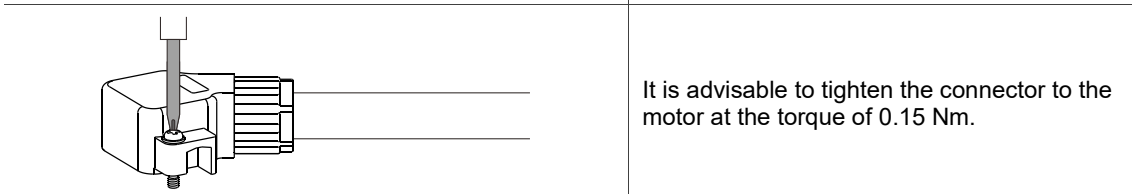

It is advisable to tighten the connector to the motor at the torque of 0.15 Nm.

3.1.7.2 F100 - F180 models (4.5 kW or below) – power connector

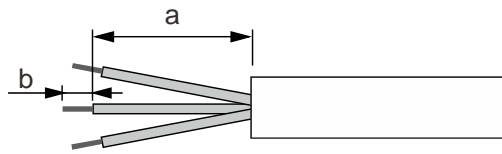

Step 1:  
Cut through the cable and expose the shielding. The exposed wire length (a) should be 23 - 27 mm (0.9 - 1.06 inches) for straight connectors and 28 - 32 mm (1.1 - 1.26 inches) for right angle connectors, and the tinned wire length (b) should be 3 - 5 mm (0.12 - 0.2 inches).

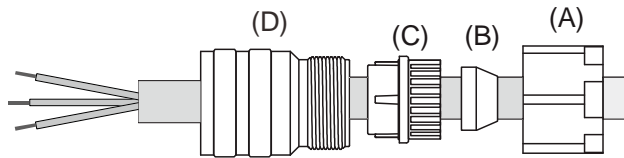

Step 2:  
Place the (A) seals nut, (B) rubber ring, (C) black compression ring, and (D) straight or angle connector on the cable in sequence.

Note: use the rubber ring corresponding to the cable in order to meet the IP67 standard.

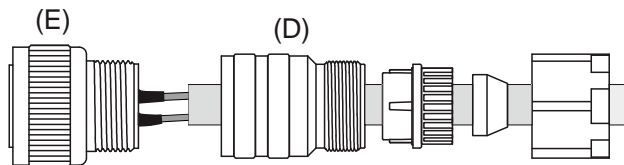

Step 3:  
■ For the power connector, refer to Section 3.1.4 for the pin assignment to connect the pins.  
■ For the encoder connector, refer to Section 3.1.5 for the pin assignment to connect the pins.

Note: it is suggested that you use 20 mm (0.79 inches) heat shrink for straight connectors, and 25 mm (0.98 inches) heat shrink for right angle connectors.

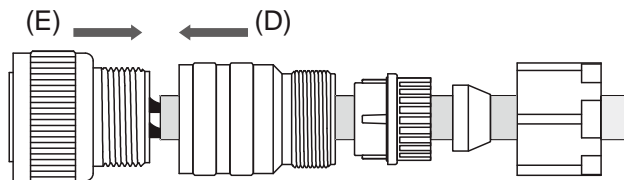

Step 4:  
Tighten (D) and (E) with adequate torque. For the torque value, refer to Section 3.1.7.3 for IP67 waterproof connector installation and wiring specifications.

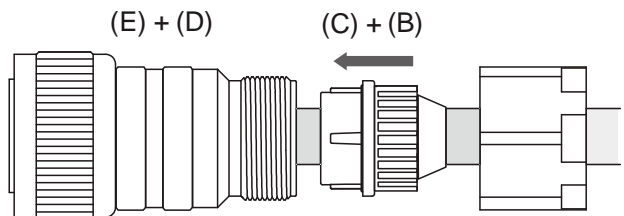

Step 5:  
Place (B) in (C), and then place (C) + (B) in (D).

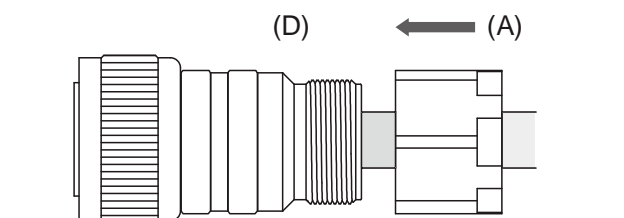

Step 6:  
Tighten (A) and (D) at the torque of 10 Nm.

### 3.1.7.3 Waterproof connector specifications

When mating, ensure the connector is fully locked and the diameter of the wire matches that of the rubber ring. If you choose a wire of smaller diameter and a rubber ring of larger diameter, the combination does not meet the IP67 standard. When selecting the wires, refer to Section 3.1.6.

#### IP67 waterproof connector installation and wiring specifications

Connector model	Diameter of rubber ring (mm)	Torque for tightening the connector
ACS3-CNPW1A00	Φ6.5 - Φ9.5	1.6 Nm
ACS3-CNPW2A00	Φ6.5 - Φ9.5	1.6 Nm
ACS3-CNEN2A00	Φ3.5 - Φ6.8	1.1 Nm
ACS3-AFPWSS00	Φ6.0 - Φ6.8	0.3 Nm
ACS3-ABPWSS00	Φ6.0 - Φ6.8	0.3 Nm
ACS3-AFEASA00	Φ5.8 - Φ6.2	0.3 Nm
ACS3-CAPWA000	Two sets of rubber rings attached Φ9 - Φ10 and Φ11 - Φ12	8 - 9 Nm (Φ9 - Φ10) 9 - 10 Nm (Φ11 - Φ12)
ACS3-CRPWA000		
ACS3-CAPWC000	Two sets of rubber rings attached Φ11 - Φ12 and Φ15 - Φ16	7.5 - 8.5 Nm (Φ11 - Φ12) 7.5 Nm (Φ15 - Φ16)
ACS3-CRPWC000		
ACS3-CABRA000	Two sets of rubber rings attached Φ4.5 - Φ5.1 and Φ5.5 - Φ6.1	1 Nm
ACS3-CRBRA000		
ACS3-CAENA000	Two sets of rubber rings attached Φ6.5 - Φ7.1 and Φ8.5 - Φ9.1	1 Nm
ACS3-CRENA000		

#### IP65 connector wiring specifications

Connector model	Wire diameter (mm)	Torque for tightening the connector
ASD-CAPW1000	Φ15 Max.	Tighten until snug
ASD-CAPW2000	Φ19 Max.	Tighten until snug

#### IP42 connector wiring specifications

Connector model	Wire diameter (mm)	Torque for tightening the connector
ACS3-CAPWE000	Φ20 Max.	Tighten until snug
ACS3-CRPWE000		

### 3.2 400V series servo system connection

#### 3.2.1 Connecting to peripheral devices (connecting to Delta communication type servo motor)



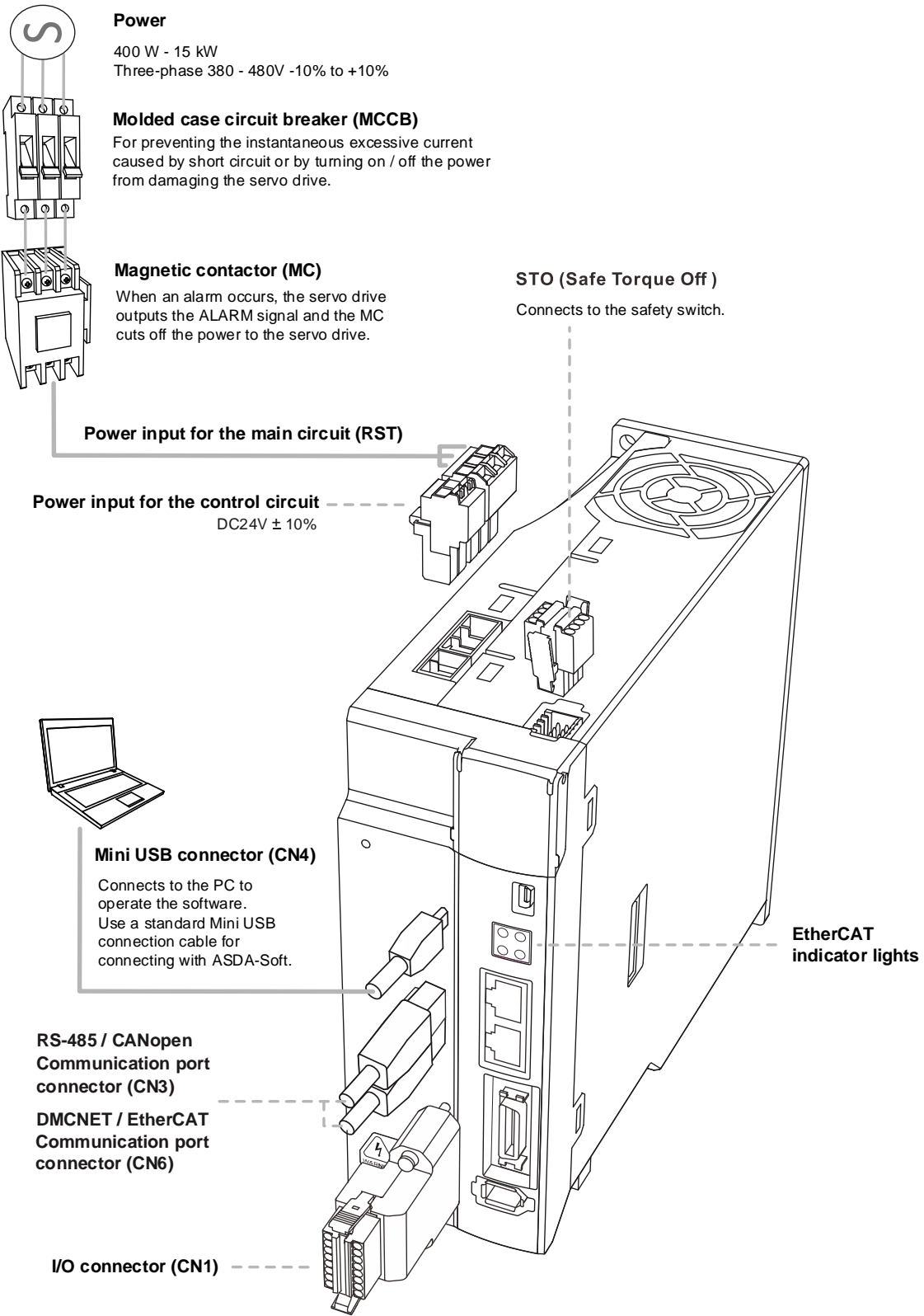

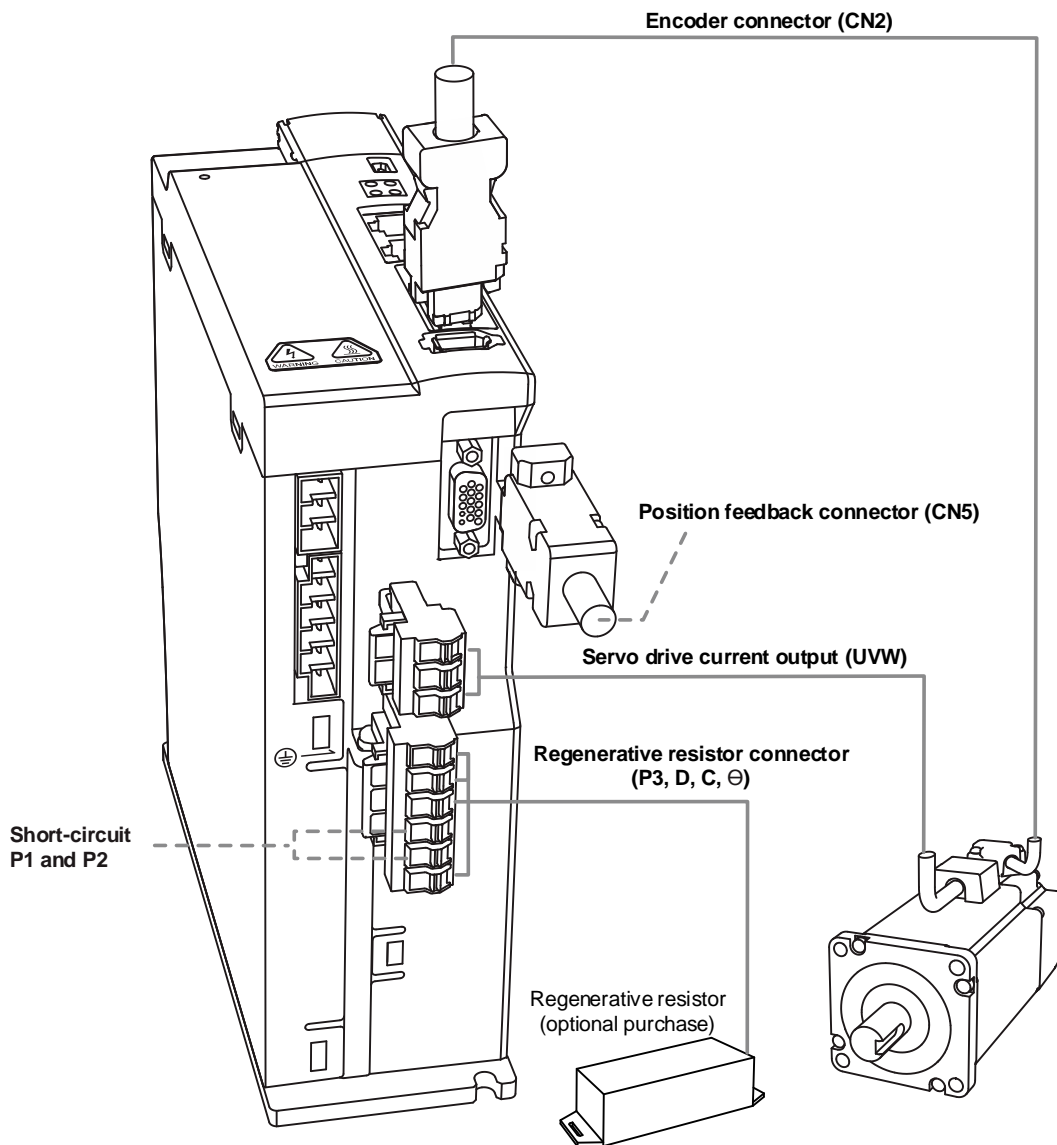
3







## 3.2.2 Connectors and terminals

Terminal	Name	Description		
DC24V, DC0V	Power input for the control circuit	Connect to DC 24V power.		
P1, P2	-	Short-circuit P1 and P2.		
R, S, T	Power input for the main circuit	Connect to three-phase AC power. (Refer to the model specification for the proper input voltage.)		
U, V, W, FG	Motor power connector	Connect to the servo motor.		
		Terminal	Color	Description
		U	Red	A three-phase main power cable for the motor.
		V	White	
		W	Black	
FG	Yellow / Green	Connect to the ground terminal  on the servo drive.		
P3, D, C, 	Regenerative resistor or regenerative unit	Use the built-in resistor	Short-circuit P3 and D contacts, and P3 and C contacts are left open.	
		Use an external resistor	Connected P3 and C contacts to the resistor.	
		Use an external regenerative unit	Connect the regenerative unit to P3 and  on the servo drive. P3 & D contacts and P3 & C contacts are left open.	
	Ground terminals	Connect to the ground wire for the power and servo motor.		
CN1	I/O connector	Connect to the controller. Refer to Section 3.4 for more information.		
CN2	Encoder connector	Connect to the encoder or converter box. Refer to Section 3.5 for more information.		
CN3	Connector for RS-485 and CANopen	For RS-485 and CANopen communication. Refer to Section 3.6 for more information.		
CN4	Mini USB connector	Connect to PC or laptop. Refer to Section 3.7 for more information.		
CN5	Position feedback connector	Connect to an external linear scale or encoder for full-closed loop and motor feedback. Refer to Section 3.8 for more information.		
CN6	Connector for DMCNET / EtherCAT	For DMCNET or EtherCAT communication. Refer to Section 3.9 for more information.		
CN10	STO	For STO connection. Refer to Section 3.10 for more information.		

Pay special attention to the following when wiring:

1. Do not touch R, S, T and U, V, W immediately after the power is off since the capacitance inside the servo drive can still contain a dangerously large amount of electric charge. Wait until the charging light is off.
2. Separate R, S, T and U, V, W from other wires. The separation should be at least 30 cm (11.8 inches).
3. For the connection cable for CN2 and CN5, use a metal braided shielded twisted-pair cable that conforms to UL2464 specifications.
4. When using RS-485, CANopen, DMCNET, or EtherCAT, use the shielded twisted-pair communication cable to ensure the communication quality.
5. When selecting the wires, refer to Section 3.2.6.
6. Do not use any external capacitors, or it may damage the servo drive.

### 3.2.3 Wiring for power supply

The power supply wiring for the 400V series servo drive is three-phase. In the following diagram, Power 1 and ALRM\_RY\_A are normally open contacts, and Power 2 is a normally closed contact. MC (magnetic contactor) is the power relay and the contact for the main power circuit.

- Wiring method for three-phase power supply (for all 400V series)

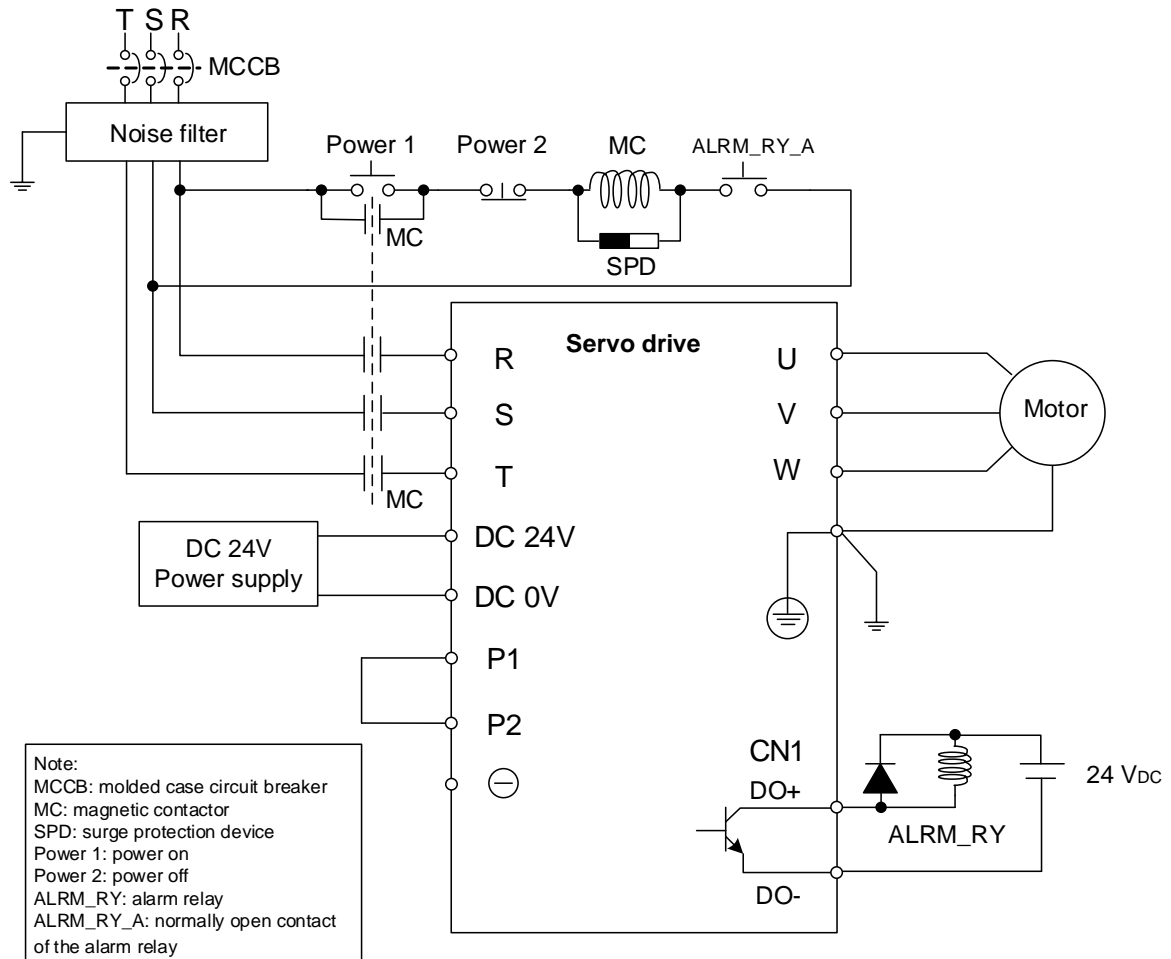

Note: wire the CN1 connector with the actual DO parameters of each model.

### 3.2.4 UVW power connector specifications

Select the power connector based on your motor frame size.

#### 3.2.4.1 F40 - F80 motors – Power connectors

Specifications of power connectors for F40 - F80 motors are the same for both 400V and 220V servo drives. However, the F40 - F80 motors for 400V servo drives only support the **standard connector** and **do not support** CHOGORI connectors and bulkhead connectors. Refer to Section 3.1.4.1 for details.

Motor model			
ECM-B3 <sup>①</sup> -J <sup>②</sup> 0604 <sup>③④⑤</sup>	ECM-B3 <sup>①</sup> -J <sup>②</sup> 0807 <sup>③④⑤</sup>	-	-

Note: in the servo motor model name, <sup>①</sup> represents the motor inertia, <sup>②</sup> represents the encoder type, <sup>③</sup> represents the brake or keyway / oil seal type, <sup>④</sup> represents the shaft diameter and connector type, and <sup>⑤</sup> represents the special code.

#### 3.2.4.2 F100 - F130 motors – Power connectors

Specifications of power connectors for F100 - F130 motors are the same for both 400V and 220V servo drives. Refer to Section 3.1.4.2 for details.

Motor model			
ECM-B3 <sup>①</sup> -J <sup>②</sup> 1010 <sup>③④⑤</sup>	ECM-B3 <sup>①</sup> -K <sup>②</sup> 1310 <sup>③④⑤</sup>	ECM-B3 <sup>①</sup> -K <sup>②</sup> 1320 <sup>③④⑤</sup>	ECM-B3 <sup>①</sup> -L <sup>②</sup> 1313 <sup>③④⑤</sup>
ECM-B3 <sup>①</sup> -J <sup>②</sup> 1015 <sup>③④⑤</sup>	ECM-B3 <sup>①</sup> -K <sup>②</sup> 1315 <sup>③④⑤</sup>	ECM-B3 <sup>①</sup> -L <sup>②</sup> 1308 <sup>③④⑤</sup>	ECM-B3 <sup>①</sup> -L <sup>②</sup> 1318 <sup>③④⑤</sup>
ECM-B3 <sup>①</sup> -J <sup>②</sup> 1020 <sup>③④⑤</sup>	-	-	-

Note: in the servo motor model name, <sup>①</sup> represents the motor inertia, <sup>②</sup> represents the encoder type, <sup>③</sup> represents the brake or keyway / oil seal type, <sup>④</sup> represents the shaft diameter and connector type, and <sup>⑤</sup> represents the special code.

#### 3.2.4.3 F180 4.5 kW (or below) motors – Power connectors

Specifications of power connectors for F180 4.5 kW (or below) motors are the same for both 400V and 220V servo drives. Refer to Section 3.1.4.3 for details.

Motor model			
ECM-B3 <sup>①</sup> -K <sup>②</sup> 1820 <sup>③④⑤</sup>	ECM-B3 <sup>①</sup> -L <sup>②</sup> 1830 <sup>③④⑤</sup>	ECM-B3 <sup>①</sup> -L <sup>②</sup> 1845 <sup>③④⑤</sup>	-

Note: in the servo motor model name, <sup>①</sup> represents the motor inertia, <sup>②</sup> represents the encoder type, <sup>③</sup> represents the brake or keyway / oil seal type, <sup>④</sup> represents the shaft diameter and connector type, and <sup>⑤</sup> represents the special code.

#### 3.2.4.4 F180 5.5 kW (or above) & F220 motors – Power connectors

Specifications of power connectors for F180 5.5 kW (or above) and F220 motors are the same for both 400V and 220V servo drives. Refer to Section 3.1.4.4 for details.

Motor model			
ECM-B3 <sup>①</sup> -L <sup>②</sup> 1855 <sup>③④⑤</sup>	ECM-B3 <sup>①</sup> -L <sup>②</sup> 1875 <sup>③④⑤</sup>	ECM-B3 <sup>①</sup> -L <sup>②</sup> 221B <sup>③④⑤</sup>	ECM-B3 <sup>①</sup> -L <sup>②</sup> 221F <sup>③④⑤</sup>

Note: in the servo motor model name, <sup>①</sup> represents the motor inertia, <sup>②</sup> represents the encoder type, <sup>③</sup> represents the brake or keyway / oil seal type, <sup>④</sup> represents the shaft diameter and connector type, and <sup>⑤</sup> represents the special code.

# 3

## 3.2.5 Encoder cable and connector specifications

Select the encoder connector based on your motor frame size.

### 3.2.5.1 F40 - F80 motors – Encoder connectors

Specifications of encoder connectors for F40 - F80 motors are the same for both 400V and 220V servo drives. However, the F40 - F80 motors for 400V servo drives only support the **standard connector** and **do not support** CHOGORI connectors and bulkhead connectors. Refer to Section 3.1.5.1 for details.

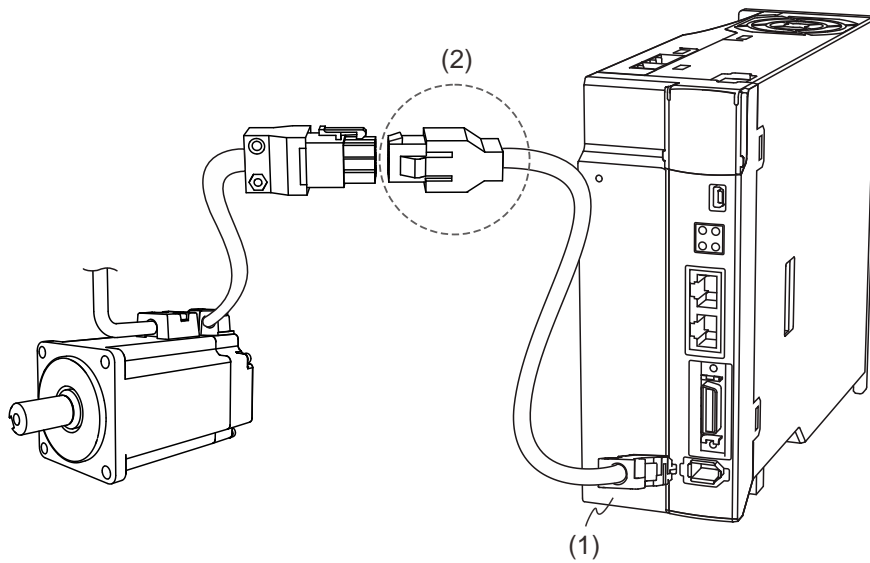

Motor model			
ECM-B3[1]-J[2]0604[3][4][5]	ECM-B3[1]-J[2]0807[3][4][5]	-	-

Note: in the servo motor model name, [1] represents the motor inertia, [2] represents the encoder type, [3] represents the brake or keyway / oil seal type, [4] represents the shaft diameter and connector type, and [5] represents the special code.

### 3.2.5.2 F100 - F220 ECM-B3 motors – Encoder connectors

Specifications of encoder connectors for F100 - F220 ECM-B3 motors are the same for both 400V and 220V servo drives. Refer to Section 3.1.5.3 for details.

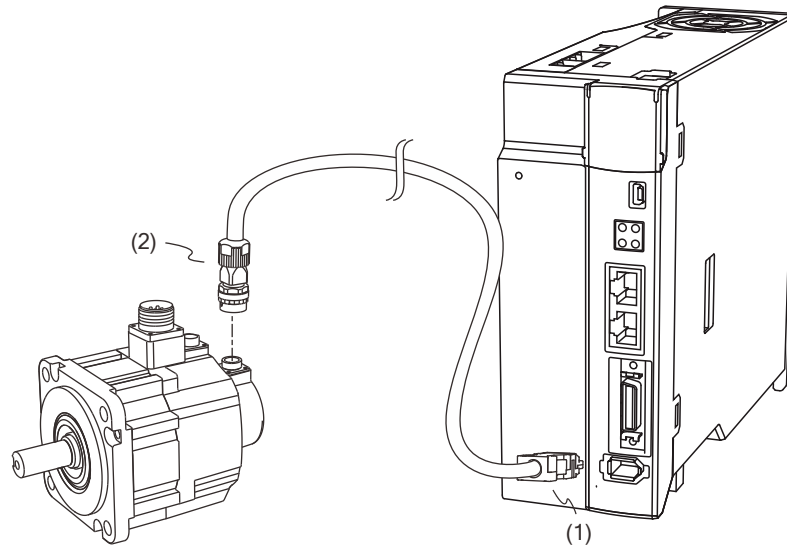

Motor model			
ECM-B3[1]-J[2]1010[3][4][5]	ECM-B3[1]-K[2]1310[3][4][5]	ECM-B3[1]-K[2]1320[3][4][5]	ECM-B3[1]-L[2]1313[3][4][5]
ECM-B3[1]-J[2]1015[3][4][5]	ECM-B3[1]-K[2]1315[3][4][5]	ECM-B3[1]-L[2]1308[3][4][5]	ECM-B3[1]-L[2]1318[3][4][5]
ECM-B3[1]-J[2]1020[3][4][5]	ECM-B3[1]-K[2]1820[3][4][5]	ECM-B3[1]-L[2]1830[3][4][5]	ECM-B3[1]-L[2]1845[3][4][5]
ECM-B3[1]-L[2]1855[3][4][5]	ECM-B3[1]-L[2]1875[3][4][5]	ECM-B3[1]-L[2]221B[3][4][5]	ECM-B3[1]-L[2]221F[3][4][5]

Note: in the servo motor model name, [1] represents the motor inertia, [2] represents the encoder type, [3] represents the brake or keyway / oil seal type, [4] represents the shaft diameter and connector type, and [5] represents the special code.

## 3.2.6 Wire selection

### 3.2.6.1 Wire diameters and terminals / ferrules

The recommended wire for connectors and signal wiring for the servo drive as listed in the following tables:

- For the pluggable terminal blocks on 1.5 kW (or below), use wire ferrules (end cord insulated terminals).
- For the screw terminal blocks on 2 kW (or above) models, use ring terminals.
- The suggested brand in the following table is K.S. Terminals Inc. Refer to Section 3.1.6.2 and 3.2.6.2 for the suitable ferrule / terminal specifications.

Servo drive model	DC24V, DC0V		R, S, T, P1, P2		U, V, W		P3, D, C, ⊖	
	Wire diameter	Wire ferrule	Wire diameter	Wire ferrule	Wire diameter	Wire ferrule	Wire diameter	Wire ferrule
ASD-A3-0443- $\square$	0.32 mm <sup>2</sup> (22 AWG)	E0308	0.32 mm <sup>2</sup> (22 AWG)	E0308	0.82 mm <sup>2</sup> (18 AWG)	E1012	0.32 mm <sup>2</sup> (22 AWG)	E0308
ASD-A3-0743- $\square$		E0308	0.52 mm <sup>2</sup> (20 AWG)	E0512		E1012	0.52 mm <sup>2</sup> (20 AWG)	E0512
ASD-A3-1043- $\square$		E0308		E0512	1.3 mm <sup>2</sup> (16 AWG)	E1512		0.82 mm <sup>2</sup> (18 AWG)
ASD-A3-1543- $\square$		E0308	0.82 mm <sup>2</sup> (18 AWG)	E1012		E1512	E1012	

Servo drive model	DC24V, DC0V		R, S, T, P1, P2		U, V, W		P3, C, ⊖	
	Wire diameter	Ring terminal	Wire diameter	Ring terminal	Wire diameter	Ring terminal	Wire diameter	Ring terminal
ASD-A3-2043- $\square$	0.52 mm <sup>2</sup> (20 AWG)	RVBL1-4	1.3 mm <sup>2</sup> (16 AWG)	RVBL2-4	2.1 mm <sup>2</sup> (14 AWG)	RVBL2-4	1.3 mm <sup>2</sup> (16 AWG)	RVBL2-4
ASD-A3-3043- $\square$		RVBL1-4	2.1 mm <sup>2</sup> (14 AWG)	RVBL2-4		RVBL2-4		RVBL2-4
ASD-A3-4543- $\square$		RVBL1-4	3.3 mm <sup>2</sup> (12 AWG)	RVBS5-4	3.3 mm <sup>2</sup> (12 AWG)	RVBS5-4	2.1 mm <sup>2</sup> (14 AWG)	RVBL2-4
ASD-A3-5543- $\square$		RVBL1-4	5.3 mm <sup>2</sup> (10 AWG)	RVBS5-4		RVBS5-4	RVBS5-4	3.3 mm <sup>2</sup> (12 AWG)
ASD-A3-7543- $\square$	RVBL1-4	RVBS5-4		RVBS5-4	5.3 mm <sup>2</sup> (10 AWG)	RVBS5-4	5.3 mm <sup>2</sup> (10 AWG)	RVBS5-4
ASD-A3-1B43- $\square$	0.82 mm <sup>2</sup> (18 AWG)	RVB1-5	8.4 mm <sup>2</sup> (8 AWG)	RNYBS8-5		RVB5-6		RVBS5-4
ASD-A3-1F43- $\square$		RVB1-5		RNYBS8-5	8.4 mm <sup>2</sup> (8 AWG)	RNYBS8-6	8.4 mm <sup>2</sup> (8 AWG)	RNYBS8-5

**Note:**

1. In the servo drive model name,  $\square$  represents the model type.
2. The shield should connect to the  $\oplus$  phase of the ground terminal.
3. When wiring, use the wires suggested in this section to avoid danger.
4. Choose the suitable terminals that comply with the wiring specifications. Use a crimping tool to properly crimp the terminals / ferrules and wires.
5. Do not use bare wires for wiring, or the loose wires may cause accidents.
6. For wiring with wire ferrules, refer to Section 3.1.6.2.

### 3.2.6.2 Screw terminal block dimensions / screw and tightening torque specifications

#### Screw terminal block dimensions

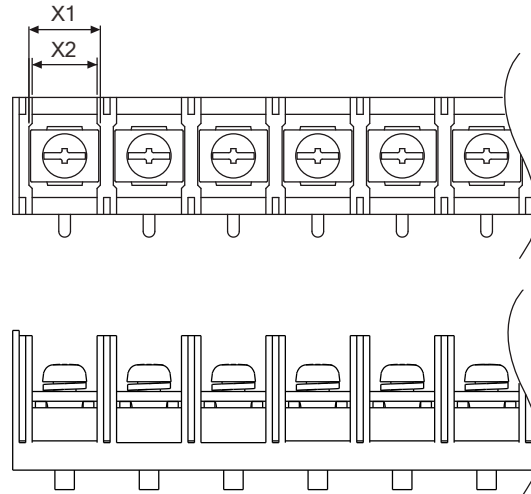

Servo drive	X1 mm (inch) / X2 mm (inch)				
	DC24V, DC0V	R, S, T, P1, P2	U, V, W	P3, C, ⊖	⊕
ASD-A3-2043-□	10 (0.39) / 11 (0.43)	10 (0.39) / 11 (0.43)	10 (0.39) / 11 (0.43)	10 (0.39) / 11 (0.43)	-
ASD-A3-3043-□	10 (0.39) / 11 (0.43)	10 (0.39) / 11 (0.43)	10 (0.39) / 11 (0.43)	10 (0.39) / 11 (0.43)	-
ASD-A3-4543-□	10 (0.39) / 11 (0.43)	10 (0.39) / 11 (0.43)	10 (0.39) / 11 (0.43)	10 (0.39) / 11 (0.43)	-
ASD-A3-5543-□	10 (0.39) / 11 (0.43)	10 (0.39) / 11 (0.43)	10 (0.39) / 11 (0.43)	10 (0.39) / 11 (0.43)	-
ASD-A3-7543-□	10 (0.39) / 11 (0.43)	10 (0.39) / 11 (0.43)	10 (0.39) / 11 (0.43)	10 (0.39) / 11 (0.43)	-
ASD-A3-1B43-□	10.5 (0.41) / 11 (0.43)	10.5 (0.41) / 11 (0.43)	12 (0.47) / 13 (0.51)	10.5 (0.41) / 11 (0.43)	-
ASD-A3-1F43-□	10.5 (0.41) / 11 (0.43)	10.5 (0.41) / 11 (0.43)	12 (0.47) / 13 (0.51)	10.5 (0.41) / 11 (0.43)	-

Note: in the servo drive model name, □ represents the model type.

#### Screw specifications and tightening torque

Servo drive model	Screw specifications and tightening torque (kgf-cm)									
	DC24V, DC0V		R, S, T, P1, P2		U, V, W		P3, C, ⊖		⊕	
ASD-A3-0443-□ ASD-A3-0743-□ ASD-A3-1043-□ ASD-A3-1543-□	-	-	-	-	-	-	-	-	M4	12 - 14
ASD-A3-2043-□	M4	12	M4	12	M4	12	M4	12	M4	12 - 14
ASD-A3-3043-□	M4	12	M4	12	M4	12	M4	12	M4	12 - 14
ASD-A3-4543-□	M4	12	M4	12	M4	12	M4	12	M4	12 - 14
ASD-A3-5543-□	M4	12	M4	12	M4	12	M4	12	M4	12 - 14
ASD-A3-7543-□	M4	12	M4	12	M4	12	M4	12	M4	12 - 14
ASD-A3-1B43-□	M4	12	M4	12	M6	27	M4	12	M4	12 - 14
ASD-A3-1F43-□	M4	12	M4	12	M6	27	M4	12	M4	12 - 14

Note: in the servo drive model name, □ represents the model type.

Tightening torque (kgf-cm)	
CN1	CN5
2 - 2.5	



## 3

**3.2.6.3 Cable specifications**

For the encoder cable specifications, refer to [Section 3.1.6.4](#). For the power cable specifications, refer to [Section 3.1.6.5](#). For the flexible cable specifications, refer to [Section 3.1.6.6](#).

**3.2.6.4 Waterproof connector specifications**

Models of 400V F40 - F80 do not support waterproof connectors. For the waterproof connectors for F100 - F220 models, refer to [Section 3.1.7](#).

## 3.3 Servo system wiring diagram

### 3.3.1 220V series models

#### 400 W (and below) models

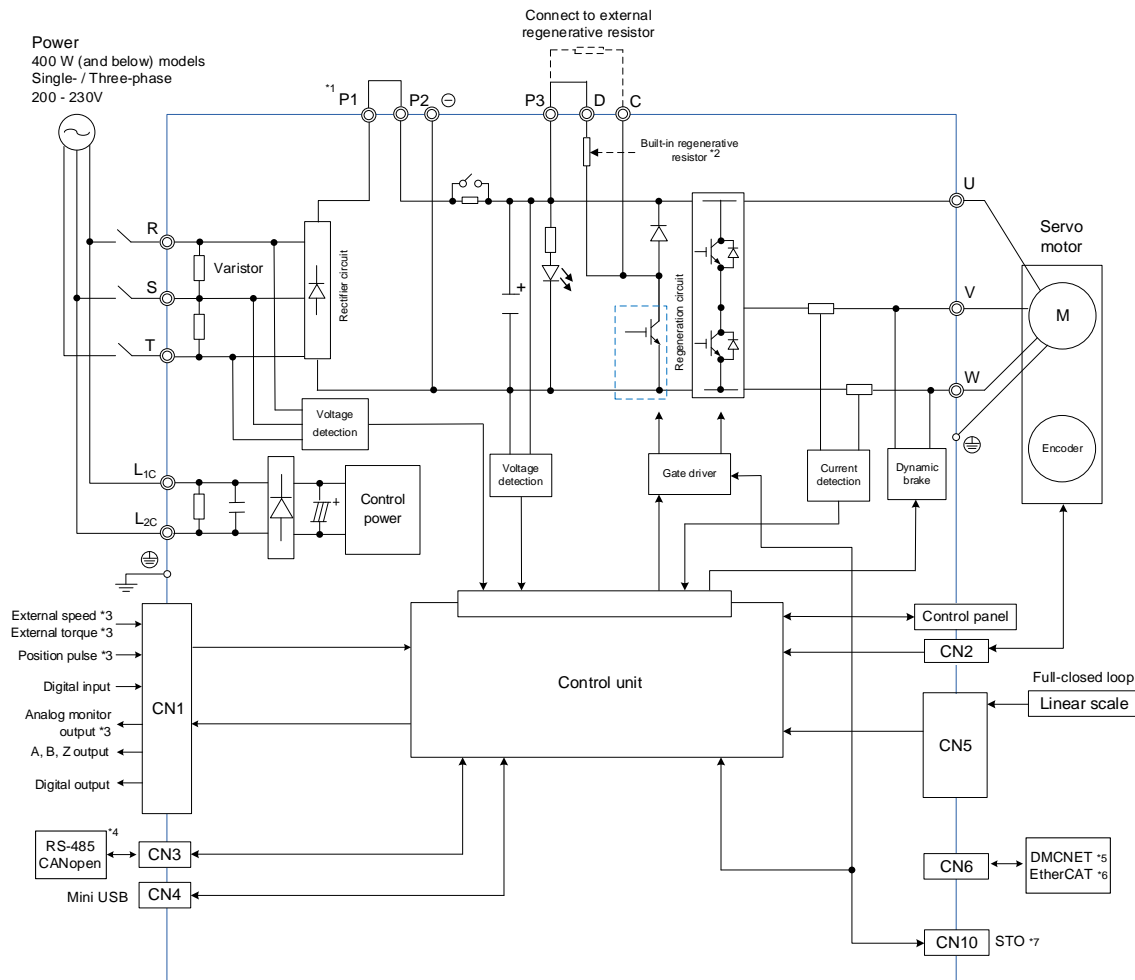

#### Note:

- \*1. Short-circuit P1 and P2 as shown in the figure.
- \*2. Models of 200 W and below do not have built-in regenerative resistors; models of 400 W have built-in regenerative resistors.
- \*3. Functions that are not provided by A3-F and A3-E.
- \*4. Serial communication (RS-485) is available on A3-L and A3-M only; CANopen is available on A3-M only.
- \*5. DMCNET is available on A3-F only.
- \*6. EtherCAT is available on A3-E only.
- \*7. STO function is available on A3-M and A3-E only.

750 W - 3 kW models

Power  
 750 W - 1.5 kW models  
 Single- / Three-phase 200 - 230V  
 2 kW - 3 kW models  
 Three-phase 200 - 230V

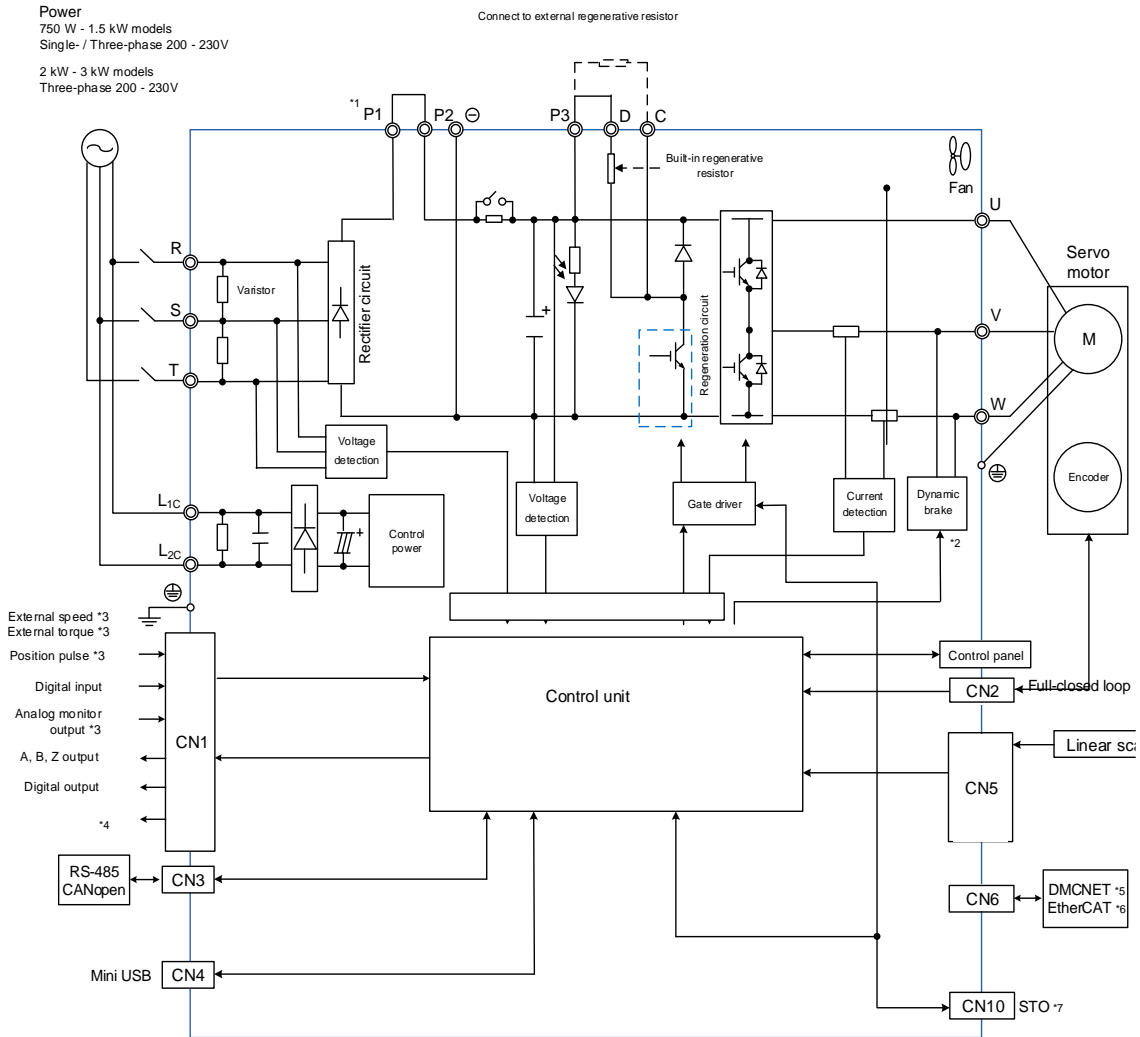

Note:

- \*1. Short-circuit P1 and P2 as shown in the figure.
- \*2. The dynamic brakes of 750 W - 3 kW models are three-phase and U, V, W is short-circuited.
- \*3. Functions that are not provided by A3-F and A3-E.
- \*4. Serial communication (RS-485) is available on A3-L and A3-M only; CANopen is available on A3-M only.
- \*5. DMCNET is available on A3-F only.
- \*6. EtherCAT is available on A3-E only.
- \*7. STO function is available on A3-M and A3-E only.

3

4.5 kW - 15 kW models

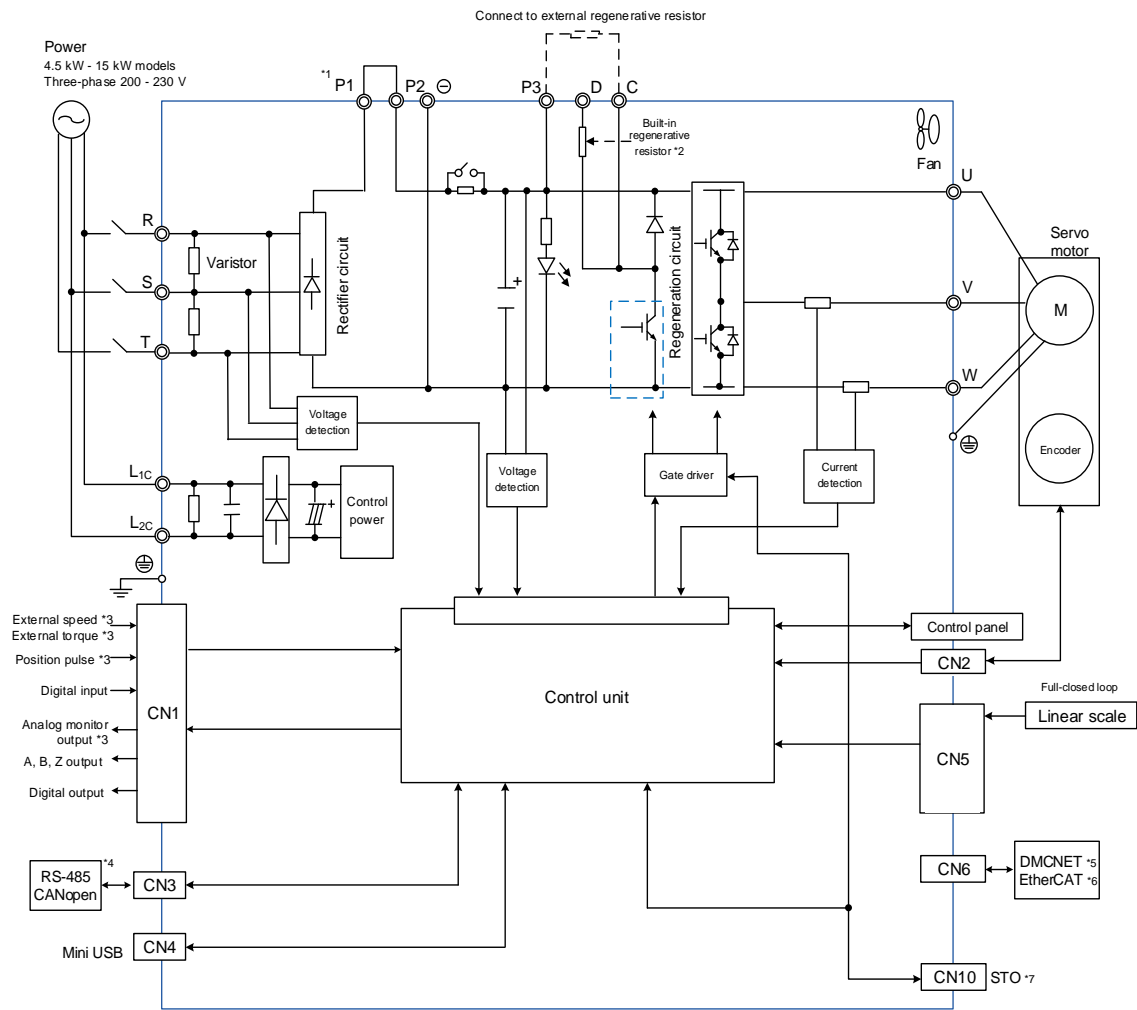

3

Note:

- \*1. Short-circuit P1 and P2 as shown in the figure.
- \*2. Models of 4.5 kW and below have built-in regenerative resistors; models of 5.5 kW do not have built-in regenerative resistors.
- \*3. Functions that are not provided by A3-F and A3-E.
- \*4. Serial communication (RS-485) is available on A3-L and A3-M only; CANopen is available on A3-M only.
- \*5. DMCNET is available on A3-F only.
- \*6. EtherCAT is available on A3-E only.
- \*7. STO function is available on A3-M and A3-E only.

### 3.3.2 400V series models

#### 400 W - 1.5 kW models

3

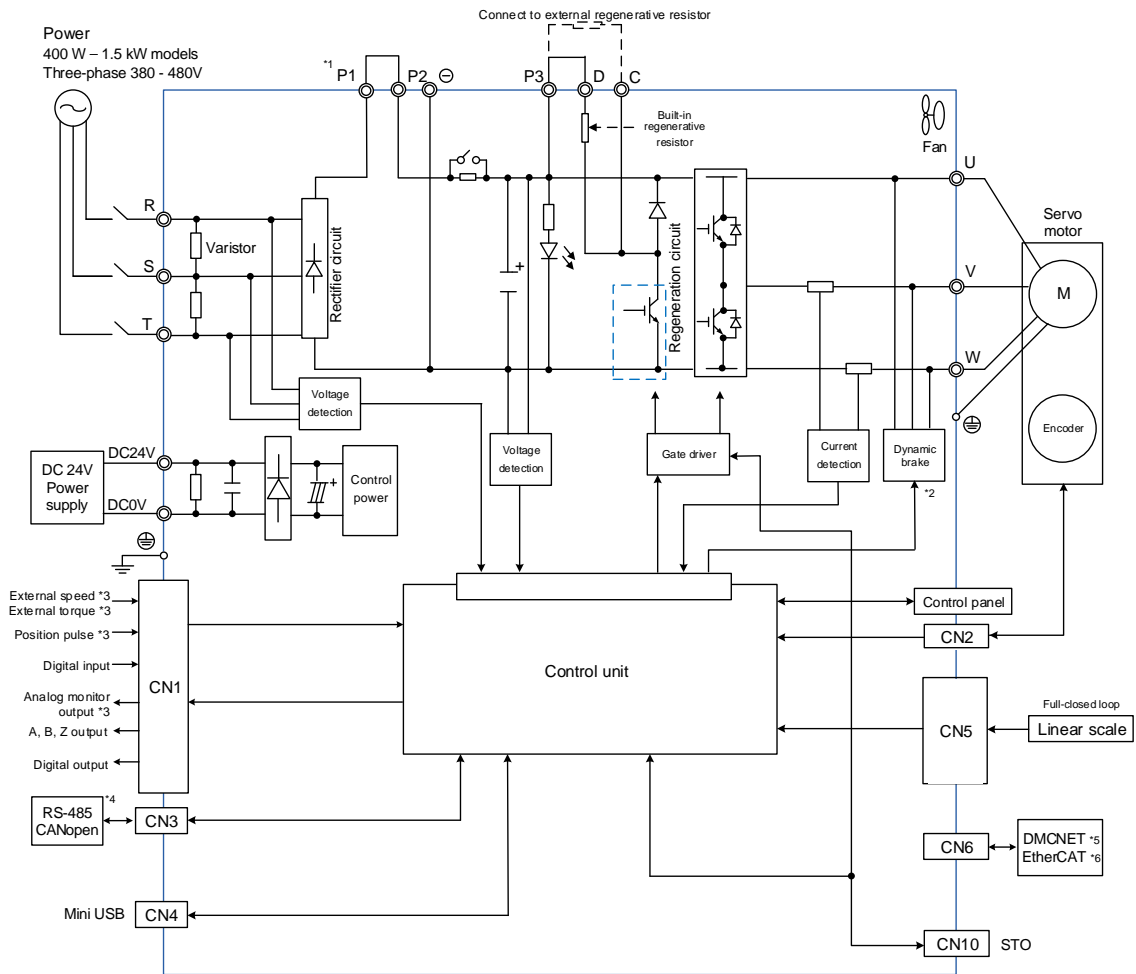

**Note:**

- \*1. Short-circuit P1 and P2 as shown in the figure.
- \*2. If the dynamic brake is in operation, the UVW is short-circuited.
- \*3. Functions that are not provided by A3-F and A3-E.
- \*4. Serial communication (RS-485) is available on A3-L and A3-M only; CANopen is available on A3-M only.
- \*5. DMCNET is available on A3-F only.
- \*6. EtherCAT is available on A3-E only.

2 kW - 15 kW models

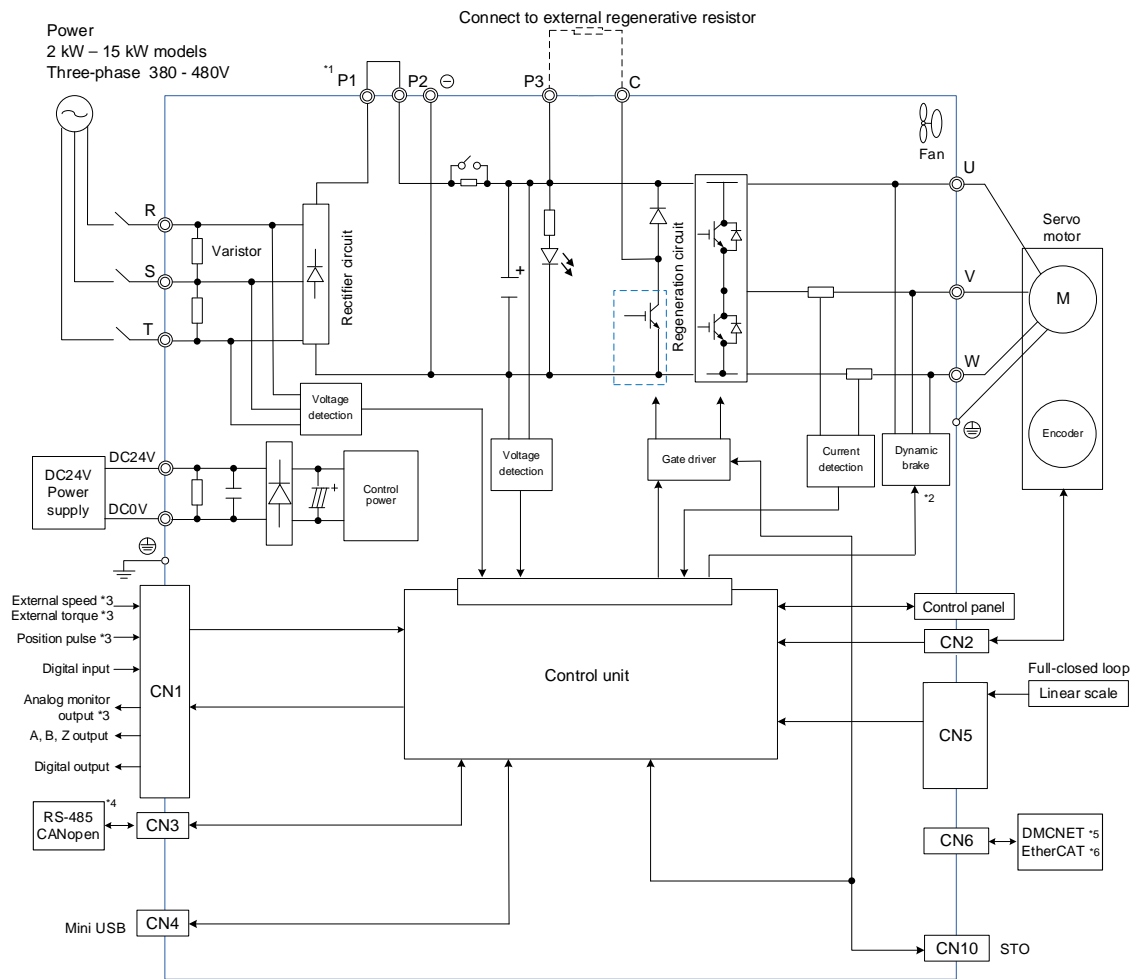

Note:

- \*1. Short-circuit P1 and P2 as shown in the figure.
- \*2. If the dynamic brake is in operation, the UVW is short-circuited.
- \*3. Functions that are not provided by A3-F and A3-E.
- \*4. Serial communication (RS-485) is available on A3-L and A3-M only; CANopen is available on A3-M only.
- \*5. DMCNET is available on A3-F only.
- \*6. EtherCAT is available on A3-E only.

3

# 3

## 3.4 Wiring for CN1 I/O connector

Pin assignments of the CN1 terminal differ from model types, refer to the corresponding wiring information based on the model.

### 3.4.1 A3-L and A3-M models – Wiring for CN1 I/O connector

#### 3.4.1.1 A3-L and A3-M models – CN1 I/O connector

On A3-L and A3-M models, the CN1 I/O connector includes 10 inputs and 6 outputs for you to define their functions. In addition, differential output signals (A+, A-, B+, B-, Z+, and Z-) for the encoder are provided. Analog torque command input, analog speed / position command input, and pulse position command input are also available. The pin assignments are shown as follows:

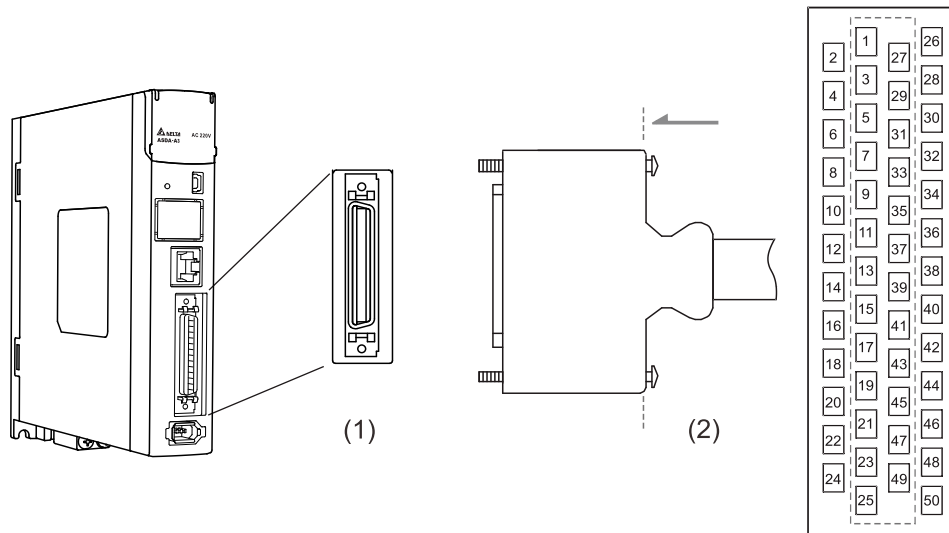

(1) CN1 connector (female); (2) CN1 connector (male)

Note: the tightening torque for the CN1 connector is 2 - 2.5 kgf-cm (1.7 - 2.2 lbf-in).

Pin assignment:

Pin	Signal	Description	Pin	Signal	Description
1	DO4+	Digital output	26	DO4-	Digital output
2	DO3-	Digital output	27	DO5-	Digital output
3	DO3+	Digital output	28	DO5+	Digital output
4	DO2-	Digital output	29	DI9-	Digital input
5	DO2+	Digital output	30	DI8-	Digital input
6	DO1-	Digital output	31	DI7-	Digital input
7	DO1+	Digital output	32	DI6-	Digital input
8	DI4-	Digital input	33	DI5-	Digital input
9	DI1-	Digital input	34	DI3-	Digital input

Pin	Signal	Description	Pin	Signal	Description
10	DI2-	Digital input	35	PULL HI_S (Sign)	External power input of command sign (24V ± 10%)
11	COM+	Power input (24V ± 10%)	36	SIGN+	Position sign ( + )
12	GND	Ground for analog / differential output signal	37	SIGN-	Position sign ( - )
13	GND	Ground for analog / differential output signal	38	DI10-	Digital input
14	NC	N/A	39	PULL HI_P (Pulse)	External power input of command pulse (24V ± 10%)
15	MON2	Analog monitor output 2	40	DO6-	Digital output
16	MON1	Analog monitor output 1	41	PULSE-	Position pulse ( - )
17	NC	N/A	42	V_REF	Analog command input speed / position ( + )
18	T_REF	Analog torque input	43	PULSE+	Position pulse ( + )
19	GND	Ground for analog / differential output signal	44	GND	Ground for analog / differential output signal
20	NC	N/A	45	NC	N/A
21	OA	Encoder A pulse differential output	46	DO6+	Digital output
22	/OA	Encoder /A pulse differential output	47	NC	N/A
23	/OB	Encoder /B pulse differential output	48	OCZ	Encoder Z pulse open-collector output
24	/OZ	Encoder /Z pulse differential output	49	NC	N/A
25	OB	Encoder B pulse differential output	50	OZ	Encoder Z pulse differential output

## Note:

1. NC represents “No connection”, which is for internal use only. Do not connect to NC, or it may damage the servo drive.
2. **When the source of the pulse input is open collector NPN or PNP type equipment, you must connect the external power (24V ± 10%) to the PULL HI pins.**
  - **Do not connect the 24V power to the SIGN+ and SIGN- pins at the same time, or the circuit elements will be damaged.**
  - **Do not connect the 24V power to the PULSE+ and PULSE- pins at the same time, or the circuit elements will be damaged.**



The following table details the signals listed in the previous page.

General signals:

Signal	Pin No.	Description	Wiring method (refer to Section 3.4.1.3)	
Analog command (input)	V_REF	42	(1) When the motor speed command is set to -10V to +10V, it means the rotation speed is -3000 to +3000 rpm (default). You can set the corresponding range with parameters. (2) When the motor position command is set to -10V to +10V, it means the range of the rotation position is -3 to +3 cycles (default).	C1
	T_REF	18	When the motor torque command is set to -10V to +10V, it means the rated torque is -100% to +100%.	C1
Analog monitor (output)	MON1 MON2	16 15	The operation status of motor, such as speed and current, can be displayed in analog voltage. This servo drive provides 2 output channels. You can select the data to be monitored with P0.003. This signal is based on the power ground.	C2
Position pulse (input)	PULSE+ PULSE-	43 41	Position pulse can be sent by line driver (single-phase max. frequency 4 MHz) or open collector (single-phase max. frequency 200 kHz). Three command types can be selected with P1.000, CW/CCW pulse, pulse + symbol, and A/B pulse.	C3 / C4
	SIGN+ SIGN-	36 37		
	PULL HI_P PULL HI_S	39 35	If using open-collector type when sending position pulses, CN1 should be connected to an external power supply (24V ± 10%) for pull high.	
Position pulse (output)	OA /OA	21 22	Encoder signals A, B, and Z differential (line driver) output.	C9 / C10
	OB /OB	25 23		
	OZ /OZ	50 24		
	OCZ	48	Encoder Z pulse open-collector output.	C11
Power	COM+	11	NPN: COM+ is for DI voltage input and requires an external power supply (24V ± 10%).	C7
			PNP: COM+ is for DI voltage input (negative end) and requires an external power supply (24V ± 10%).	C8
	GND	12, 13, 19, 44	The ground for analog signals and differential output signals.	
Others	NC	14, 17, 20 45, 47, 49	No connection. This is for internal use only. Do not connect to NC, or it may damage the servo drive.	-

There are various control modes available (refer to Section 6.1) and the I/O configuration differs for each mode. The A3-L and A3-M series models provide user-defined I/Os for you to set functions according to the application requirements. See Chapter 8 and refer to Table 8.1 Digital input (DI) descriptions and Table 8.2 Digital output (DO) descriptions. The default DI/DO signal configuration for each control mode includes the most commonly used functions and meets the requirements for general applications. To reset the signals to the default values of each corresponding mode, set P1.001.U to 1 and cycle the power to the servo drive.

See the following table for the default DI signal of each control mode:

DI	Control mode						
	PT	PR	S / Sz	T / Tz	PT-S	PT-T	PR-S
	Default	Default	Default	Default	Default	Default	Default
	Signal	Signal	Signal	Signal	Signal	Signal	Signal
1	0x01	0x01	0x01	0x01	0x01	0x01	0x01
	SON	SON	SON	SON	SON	SON	SON
2	0x04	0x08	0x09	0x10	0x04	0x04	0x08
	CCLR	CTRG	TRQLM	SPDLM	CCLR	CCLR	CTRG
3	0x16	0x11	0x14	0x16	0x14	0x16	0x11
	TCM0	POS0	SPD0	TCM0	SPD0	TCM0	POS0
4	0x17	0x12	0x15	0x17	0x15	0x17	0x12
	TCM1	POS1	SPD1	TCM1	SPD1	TCM1	POS1
5	0x02	0x02	0x02	0x02	-	-	0x14
	ARST	ARST	ARST	ARST	-	-	SPD0
6	0x22	0x22	0x22	0x22	-	-	0x15
	NL	NL	NL	NL	-	-	SPD1
7	0x23	0x23	0x23	0x23	0x18	0x20	0x18
	PL	PL	PL	PL	S-P	T-P	S-P
8	0x21	0x21	0x21	0x21	0x21	0x21	0x21
	EMGS	EMGS	EMGS	EMGS	EMGS	EMGS	EMGS
9	-	-	-	-	-	-	-
10	-	-	-	-	-	-	-

3

DI	Control mode					
	PR-T	S-T	CANopen	PT-PR	PT-PR-S	PT-PR-T
	Default	Default	Default	Default	Default	Default
	Signal	Signal	Signal	Signal	Signal	Signal
1	0x01	0x01	-	0x01	0x01	0x01
	SON	SON	-	SON	SON	SON
2	0x08	-	-	0x04	0x04	0x04
	CTRG	-	-	CCLR	CCLR	CCLR
3	0x11	0x14	-	0x08	0x08	0x08
	POS0	SPD0	-	CTRG	CTRG	CTRG
4	0x12	0x15	-	0x11	0x11	0x11
	POS1	SPD1	-	POS0	POS0	POS0
5	0x16	0x16	0x24	0x12	0x12	0x12
	TCM0	TCM0	ORGP	POS1	POS1	POS1
6	0x17	0x17	0x22	0x13	0x24	0x24
	TCM1	TCM1	NL	POS2	ORGP	ORGP
7	0x20	0x19	0x23	0x24	0x18	0x20
	T-P	S-T	PL	ORGP	S-P	T-P
8	0x21	0x21	0x21	0x2B	0x2B	0x2B
	EMGS	EMGS	EMGS	PT-PR	PT-PR	PT-PR
9	-	-	-	0x02	0x02	0x02
	-	-	-	ARST	ARST	ARST
10	-	-	-	-	-	-

Note:

1. Refer to the C7 and C8 diagrams in Section 3.4.1.3 for wiring.
2. Description of each DI signal:

DI	Description	DI	Description	DI	Description
SON	Servo activated	NL	Negative limit	PL	Positive limit
CCLR	Pulse clear	ARST	Alarm reset	EMGS	Emergency stop
CTRG	Internal position command triggered	TCM0	Torque command 0	TCM1	Torque command 1
TRQLM	Torque limit	SPD0	Speed selection 0	SPD1	Speed selection 1
SPDLM	Speed limit	POS0	Internal position selection 0	POS1	Internal position selection 1
S-P	Switch between S and P modes (dual / multi-mode)	T-P	Switch between T and P modes (dual / multi-mode)	S-T	Switch between S and T modes (dual / multi-mode)
PT-PR	Switch between PT and PR modes (dual / multi-mode)	POS2	Internal position selection 2	ORGP	ORG signal

See the following table for the default DO signal of each control mode:

DO	Control mode						
	PT	PR	S / Sz	T / Tz	PT-S	PT-T	PR-S
	Default	Default	Default	Default	Default	Default	Default
	Signal	Signal	Signal	Signal	Signal	Signal	Signal
1	0x01	0x01	0x01	0x01	0x01	0x01	0x01
	SRDY	SRDY	SRDY	SRDY	SRDY	SRDY	SRDY
2	0x03	0x03	0x03	0x03	0x03	0x03	0x03
	ZSPD	ZSPD	ZSPD	ZSPD	ZSPD	ZSPD	ZSPD
3	0x09	0x09	0x04	0x04	0x04	0x04	0x04
	HOME	HOME	TSPD	TSPD	TSPD	TSPD	TSPD
4	0x05	0x05	0x08	0x08	0x05	0x05	0x05
	TPOS	TPOS	BRKR	BRKR	TPOS	TPOS	TPOS
5	0x07	0x07	0x07	0x07	0x07	0x07	0x07
	ALRM	ALRM	ALRM	ALRM	ALRM	ALRM	ALRM
6	-	-	-	-	-	-	-

DO	Control mode					
	PR-T	S-T	CANopen	PT-PR	PT-PR-S	PT-PR-T
	Default	Default	Default	Default	Default	Default
	Signal	Signal	Signal	Signal	Signal	Signal
1	0x01	0x01	-	0x01	0x01	0x01
	SRDY	SRDY	-	SRDY	SRDY	SRDY
2	0x03	0x03	-	0x03	0x03	0x03
	ZSPD	ZSPD	-	ZSPD	ZSPD	ZSPD
3	0x04	0x04	-	0x09	0x09	0x09
	TSPD	TSPD	-	HOME	HOME	HOME
4	0x05	-	-	0x05	0x05	0x05
	TPOS	-	-	TPOS	TPOS	TPOS
5	0x07	0x07	0x07	0x07	0x07	0x07
	ALRM	ALRM	ALRM	ALRM	ALRM	ALRM
6	-	-	-	-	-	-

Note: description of each DO signal.

DO	Description	DO	Description	DO	Description
SRDY	Servo ready	HOME	Homing is complete	TSPD	Target speed reached
ZSPD	Zero motor speed	TPOS	Target position reached	ALRM	Servo alarm
BRKR	Magnetic brake	-	-	-	-

If the default DI/DO functions cannot meet the application requirements, you can refer to the following tables and specify the DI/DO functions by setting the DI and DO codes to the corresponding parameters.

Signal		CN1 Pin No.	Corresponding parameter	Signal		CN1 Pin No.	Corresponding parameter
Standard DI	DI1-	9	P2.010	Standard DI	DI6-	32	P2.015
	DI2-	10	P2.011		DI7-	31	P2.016
	DI3-	34	P2.012		DI8-	30	P2.017
	DI4-	8	P2.013		DI9-	29	P2.036
	DI5-	33	P2.014		DI10-	38	P2.037

Signal		CN1 Pin No.	Corresponding parameter	Signal		CN1 Pin No.	Corresponding parameter
Standard DO	DO1+	7	P2.018	Standard DO	DO4+	1	P2.021
	DO1-	6			DO4-	26	
	DO2+	5	P2.019		DO5+	28	P2.022
	DO2-	4			DO5-	27	
	DO3+	3	P2.020		DO6+	46	P2.041
	DO3-	2			DO6-	40	

### 3.4.1.2 A3-L and A3-M models – Quick connector

The CN1 quick connector (ACS3-IFSC5020) applicable for the A3-L and A3-M series is designed for easy wiring. You do not need to solder the wires; the spring-loaded terminals prevent the wires from loosening caused by vibration. The connector includes five digital inputs, four digital outputs, differential pulse inputs, and Z phase open-collector pulse outputs.

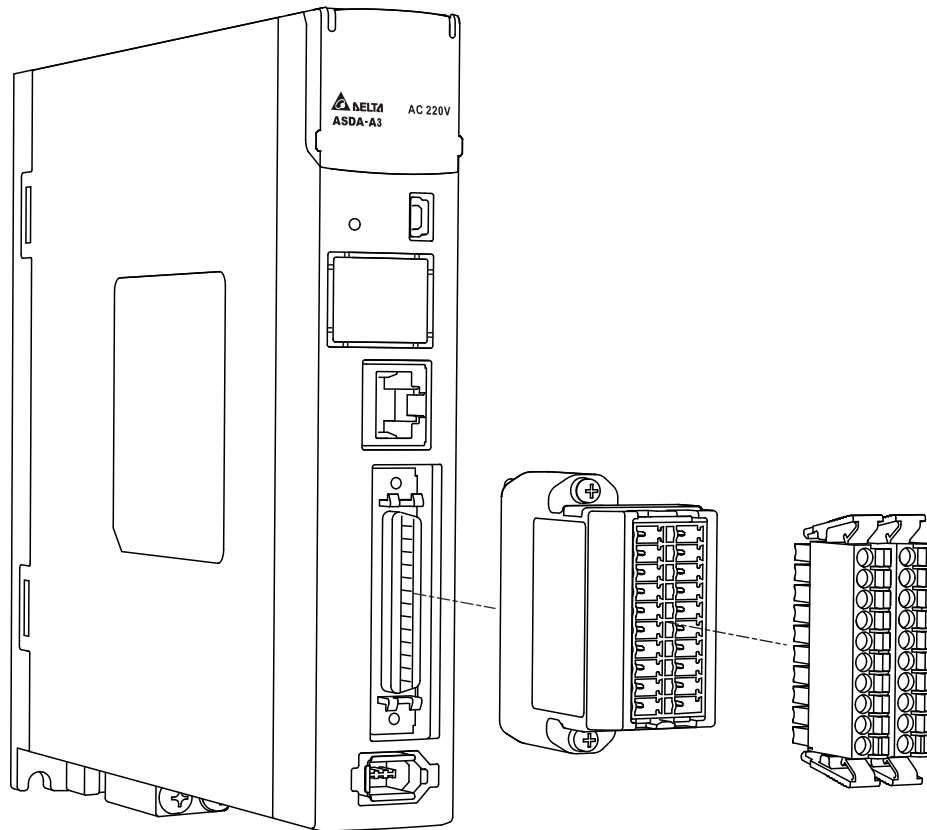

On A3-L and A3-M series models, pin assignments for J2 and J1 of the CN1 quick connector (ACS3-IFSC5020) are as follows:

# 3

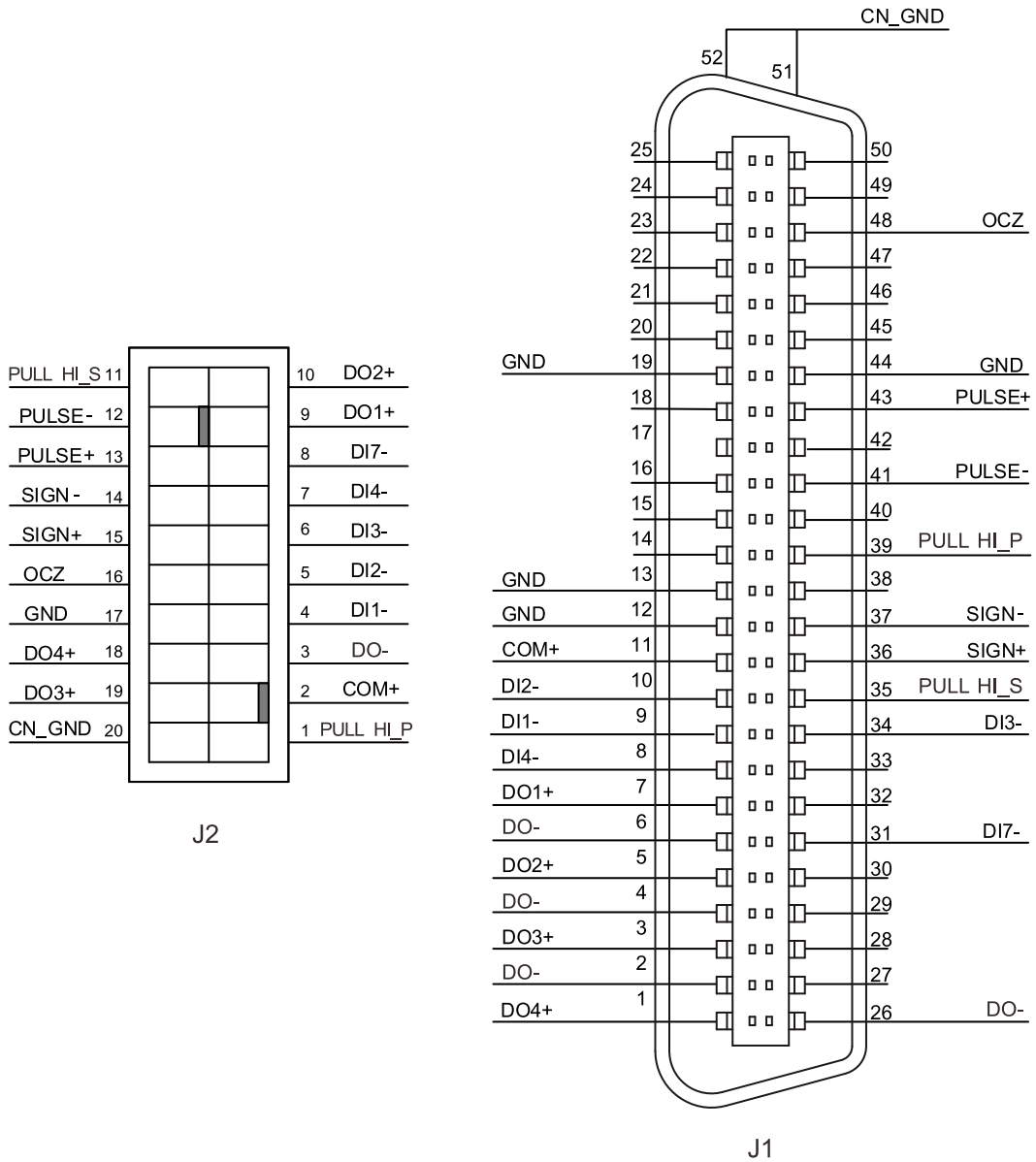

J2-PIN	Signal	J1-PIN
1	PULL HI_P	39
2	COM+	11
3	DO- (DO1-, DO2-, DO3-, DO4-)	2, 4, 6, 26
4	DI1-	9
5	DI2-	10
6	DI3-	34
7	DI4-	8
8	DI7-	31
9	DO1+	7
10	DO2+	5
11	PULL HI_S	35
12	PULSE-	41
13	PULSE+	43
14	SIGN-	37
15	SIGN+	36
16	OCZ	48
17	GND	12, 13, 19, 44
18	DO4+	1
19	DO3+	3
20	CN_GND	51, 52

Note: refer to Section 3.11 and 3.12 for standard wiring examples.



Wiring and installation for the CN1 quick connector (ACS3-IFSC5020):

### Installation

# 3

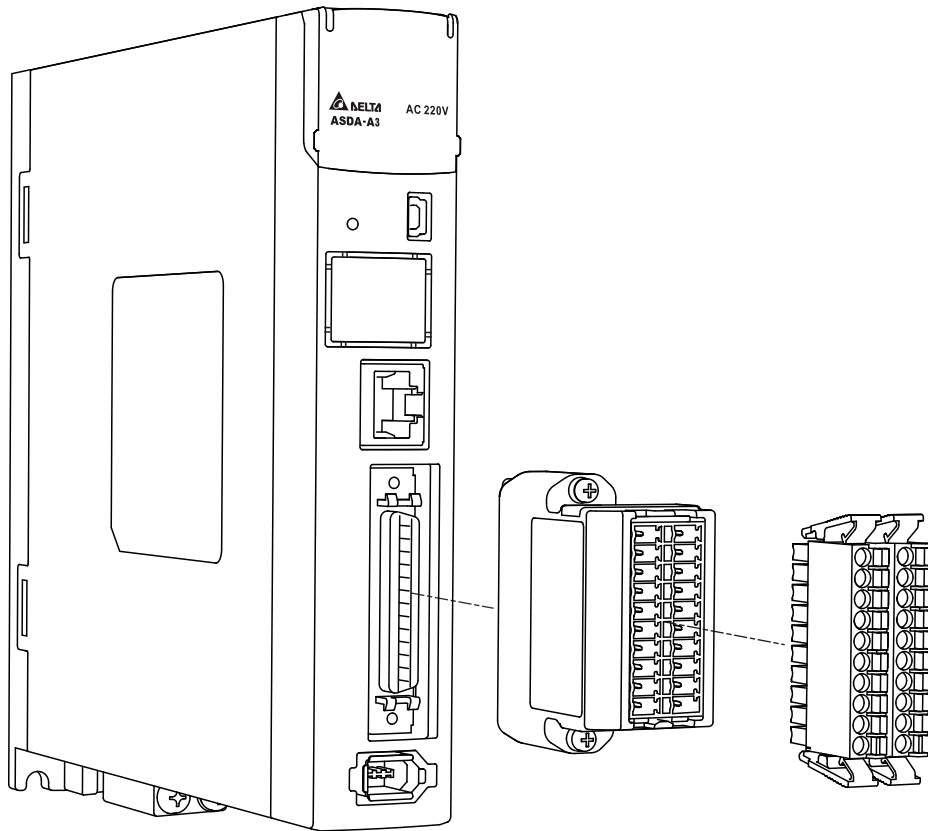

## Wiring

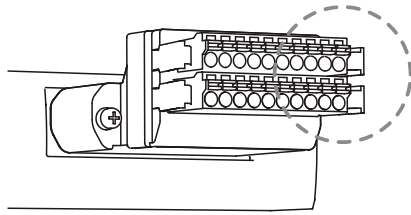

- (1) The CN1 quick connector (ACS3-IFSC5020) has multiple spring-loaded terminals. Determine which terminal is to be wired in advance.

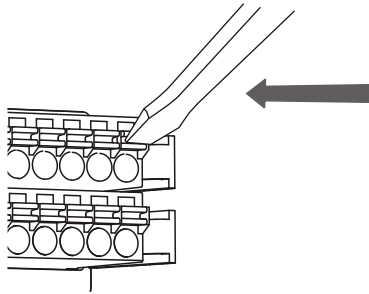

- (2) Use a flathead screwdriver to press the spring down to open the pin.

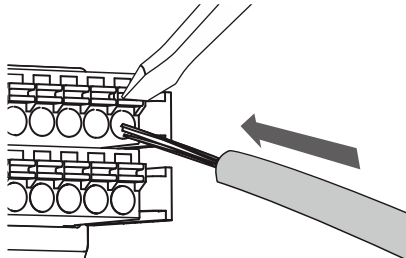

- (3) Insert the stripped wire into the pin.

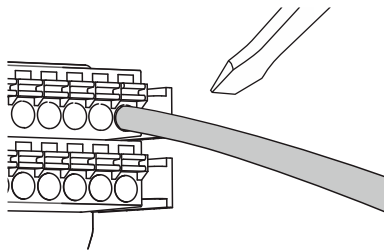

- (4) Withdraw the screwdriver to complete the wiring.

# 3

### 3.4.1.3 A3-L and A3-M models – CN1 wiring diagrams

On A3-L and A3-M models, the valid voltage for the analog speed command and the analog torque command is between -10V and +10V. You can set the command value that corresponds to the voltage range with the relevant parameters.

C1: input for analog speed / torque (force) command

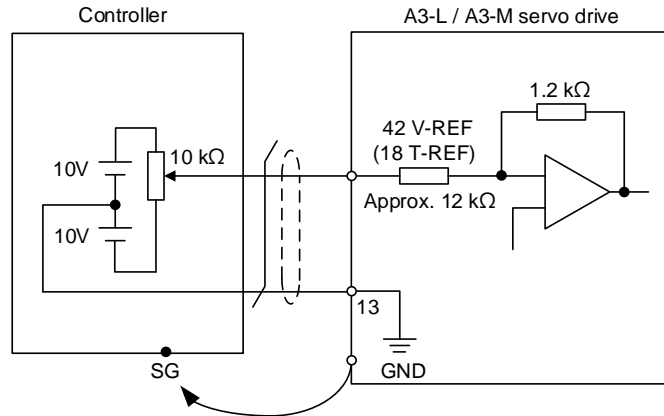

C2: output for analog monitoring command (MON1 and MON2)

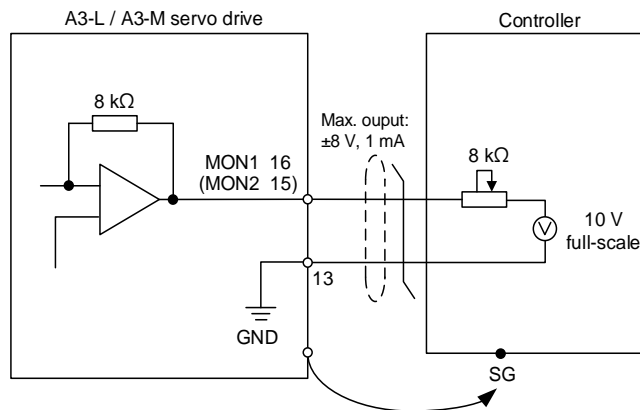

You can input the pulse command with the open collector or line driver. The maximum input pulse is 4 Mpps for the line driver and 200 kpps for the open collector.

**Caution:** when the source for the pulse input is open collector NPN type or PNP type equipment, you must connect the external power (24V  $\pm$  10%) to the PULL HI pins.

- Do not connect the 24V power to the SIGN+ and SIGN- pins at the same time, or the circuit elements will be damaged.
- Do not connect the 24V power to the PULSE+ and PULSE- pins at the same time, or the circuit elements will be damaged.

C3-1: the source for the pulse input is open-collector NPN-type device, which uses the external power supply.

#### Controller without built-in resistor

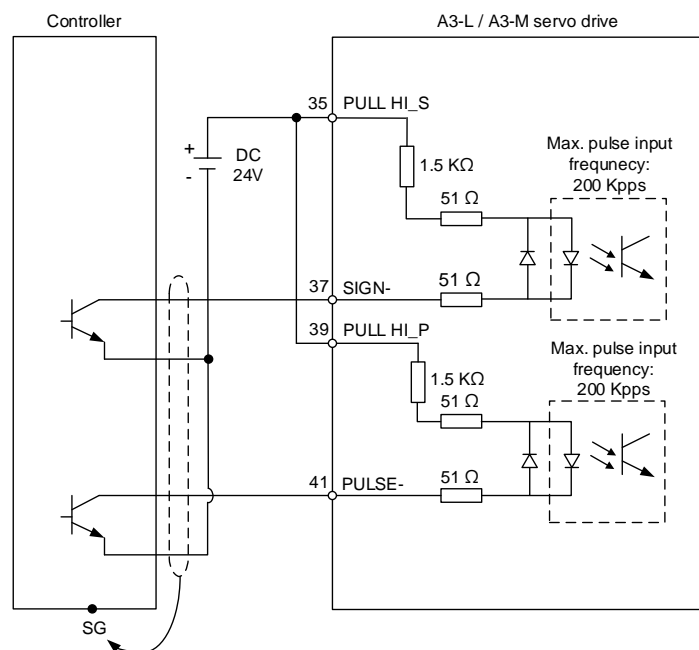

C3-2: the source for the pulse input is open-collector PNP-type device, which uses the external power supply.

# 3

## Controller without built-in resistor

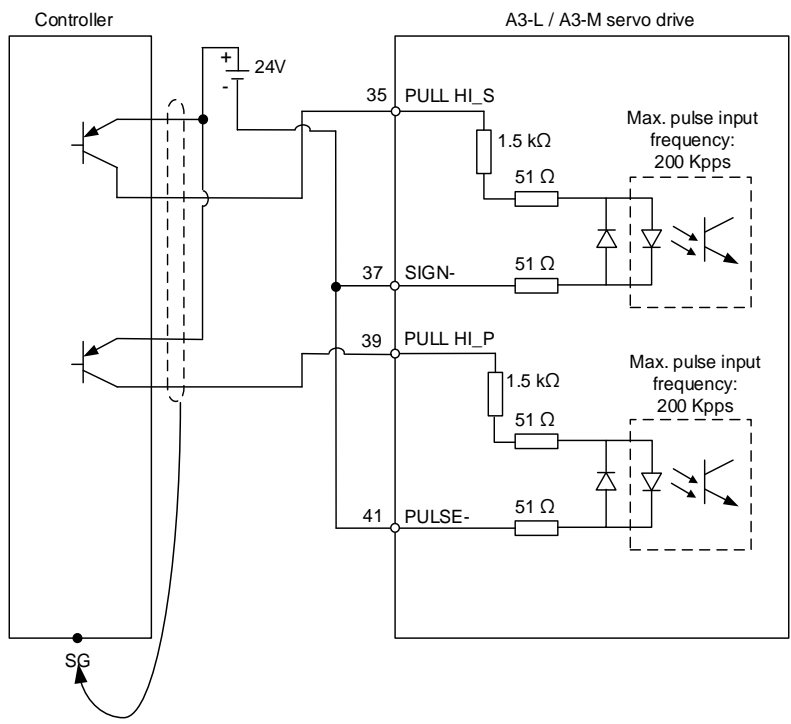

C4: pulse input (differential input) can only be used with 2.8V - 3.6V power systems. **Do not use it with 24V power.**

Pulse	Type		Maximum input frequency
High speed pulse	Differential signal	Pulse + symbol	4 Mpps
		Clockwise and counterclockwise pulse	
		AB phase pulse (4x)	2 Mpps
Low speed pulse	Differential signal		200 kpps

3

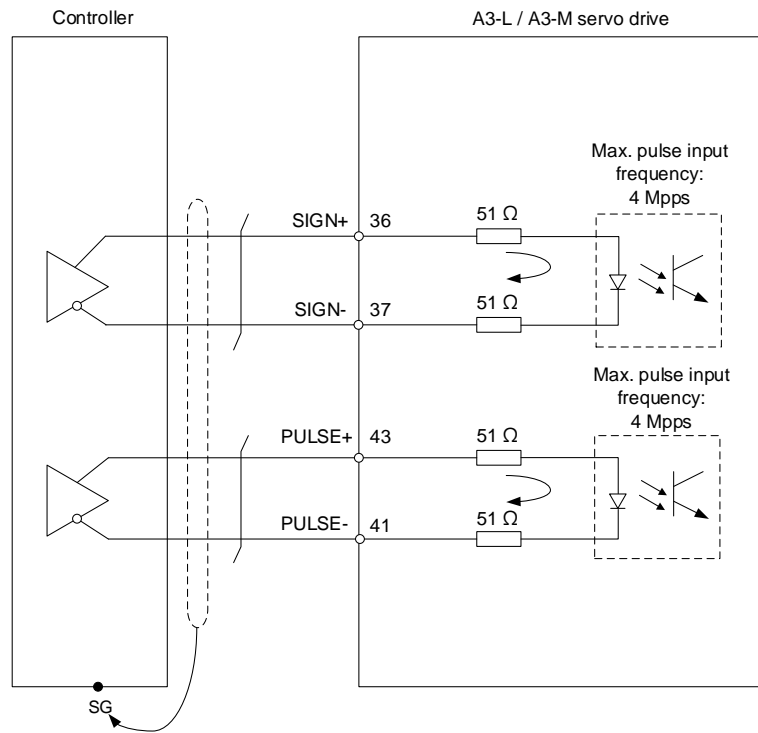

Note: refer to the description of P1.000 in Chapter 8 for setting details.

## 3

Caution: when the drive connects to an inductive load, you must install the diode.

DO specification:

Permissible current: below 40 mA; surge current: below 100 mA; maximum voltage: 30V.

Diode specification:

1A or above, 500V or above (e.g., 1N4005).

C5: DO wiring - the servo drive uses an external power supply and the resistor is for general load.

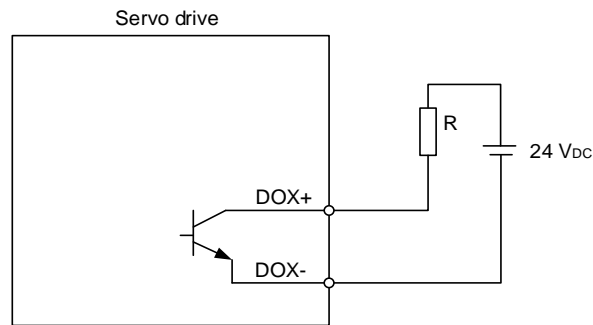

C6: DO wiring - the servo drive uses an external power supply and the resistor is for inductive load.

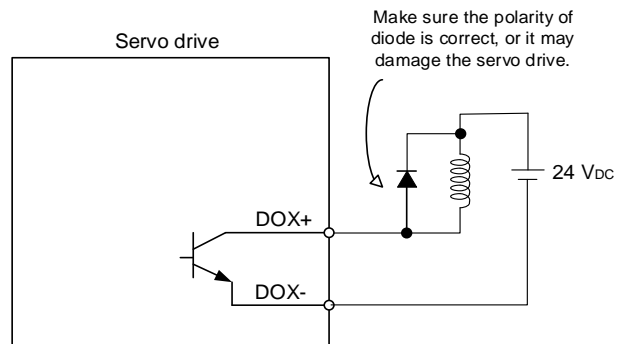

DI wiring - input signals by relay or open collector transistor.

Conditions of DI On / Off:

ON: 15V - 24V; condition: input current = 8 mA.

OFF: 5V or below; the input current must not be higher than 0.5 mA.

C7: NPN transistor (SINK mode)

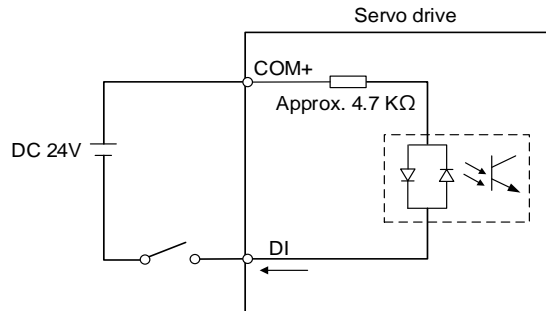

C8: PNP transistor (SOURCE mode)

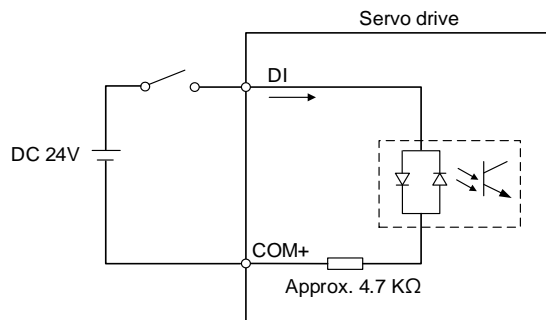

C9: output for encoder position signal (line driver)

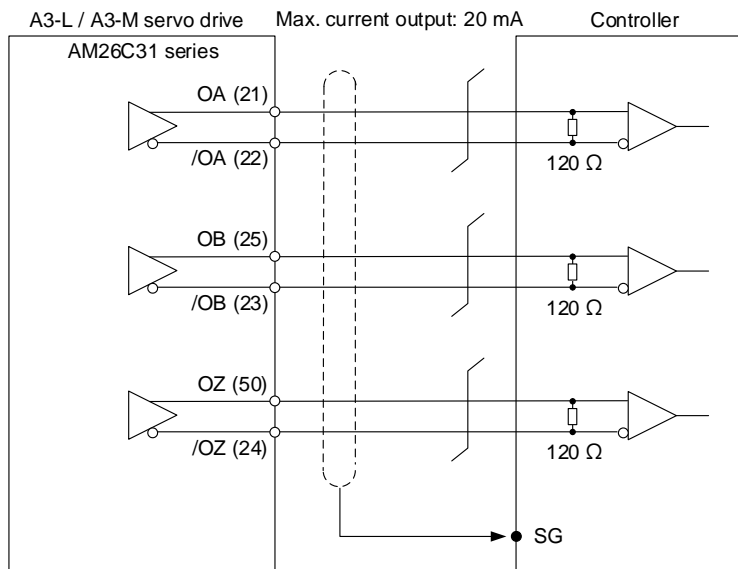

Note: it is suggested that you connect the two GNDs for the controller and servo drive in parallel when the voltage deviation between the controller and the servo drive is too great.



3

C10: output for encoder position signal (photocoupler)

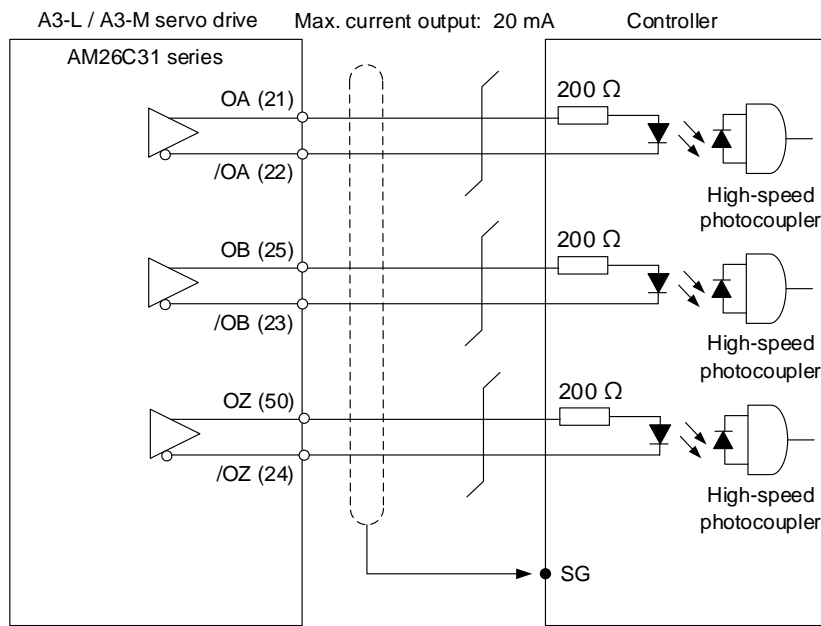

C11: encoder OCZ output (open-collector Z pulse output)

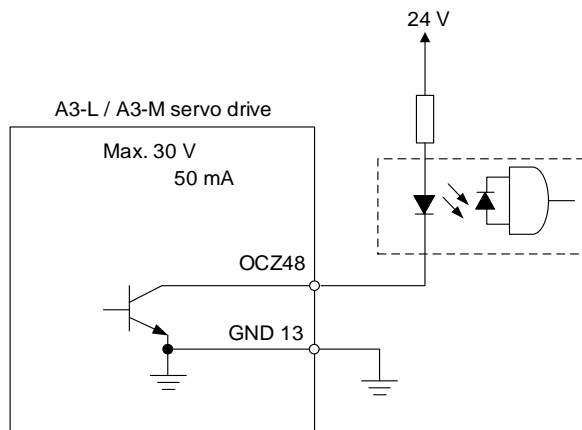

### 3.4.2 A3-E and A3-F models – Wiring for CN1 I/O connector

#### 3.4.2.1 A3-E and A3-F models – CN1 I/O connector

On A3-E and A3-F models, the CN1 I/O connector includes 7 inputs and 4 outputs for you to define their functions. In addition, differential output signals (A+, A-, B+, B-, Z+, and Z-) for the encoder are provided. The pin assignments are shown as follows.

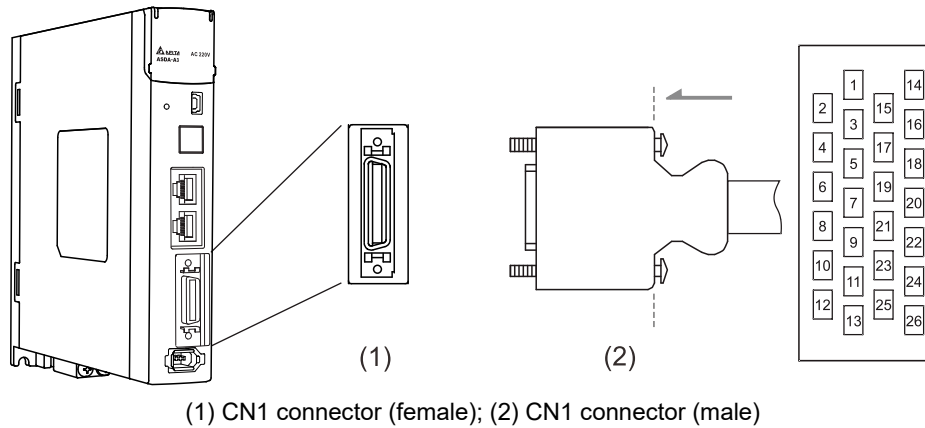

(1) CN1 connector (female); (2) CN1 connector (male)

Note: the tightening torque for the CN1 connector is 2 - 2.5 kgf-cm (1.7 - 2.2 lbf-in).

Pin assignment:

Pin	Signal	Description	Pin	Signal	Description
1	DO1+	Digital output	14	NC	N/A
2	DO1-	Digital output	15	NC	N/A
3	DO2+	Digital output	16	GND	Ground for differential output signals.
4	DO2-	Digital output	17	OA	Encoder A pulse differential output
5	NC	N/A	18	/OA	Encoder /A pulse differential output
6	COM+	Power input (24V ± 10%)	19	OB	Encoder B pulse differential output
7	DI1-	Digital input	20	/OB	Encoder /B pulse differential output
8	DI2-	Digital input	21	OZ	Encoder Z pulse differential output
9	DI3-	Digital input	22	/OZ	Encoder /Z pulse differential output
10	DI4-	Digital input	23	DO4+	Digital output
11	DI5-	Digital input	24	DO4-	Digital output
12	DI6-	Digital input	25	DO3+	Digital output
13	DI7-	Digital input	26	DO3-	Digital output

Note: NC represents “No connection”, which is for internal use only. Do not connect to NC, or it may damage the servo drive.

The following table details the signals listed in the previous page.

General signals:

Signal		Pin No.	Description	Wiring method (refer to Section 3.4.2.3)
Position pulse (output)	OA	17	Encoder signals A, B, and Z differential (line driver) output.	C9 / C10
	/OA	18		
	OB	19		
	/OB	20		
	OZ	21		
Power	COM+	6	NPN: COM+ is for DI voltage input and requires an external power supply (24V ± 10%).	C7
			PNP: COM+ is for DI voltage input (negative end) and requires an external power supply (24V ± 10%).	C8
	GND	16	Ground for differential output signal.	
Others	NC	5, 14, 15	No connection. This is for internal use only. Do not connect to NC, or it may damage the servo drive.	-

The A3-F and A3-E series models provide user-defined I/Os for you to set functions according to the application requirements. See Chapter 8 and refer to Table 8.1 Digital input (DI) descriptions and Table 8.2 Digital output (DO) descriptions. The default DI/DO signal configuration for each control mode includes the most commonly used functions and meets the requirements for general applications. To reset the signals to the default values of each corresponding mode, set P1.001.U to 1 and cycle the power to the servo drive.

See the following table for the default DI signal of each control mode:

DI	Control mode						
	PT	PR	S / Sz	T / Tz	PT-S	PT-T	PR-S
	Default	Default	Default	Default	Default	Default	Default
	Signal	Signal	Signal	Signal	Signal	Signal	Signal
1	0x01	0x01	0x01	0x01	0x01	0x01	0x01
	SON	SON	SON	SON	SON	SON	SON
2	0x04	0x08	0x09	0x10	0x04	0x04	0x08
	CCLR	CTRG	TRQLM	SPDLM	CCLR	CCLR	CTRG
3	0x16	0x11	0x14	0x16	0x14	0x16	0x11
	TCM0	POS0	SPD0	TCM0	SPD0	TCM0	POS0
4	0x02	0x02	0x02	0x02	-	-	0x12
	ARST	ARST	ARST	ARST	-	-	POS1
5	0x22	0x22	0x22	0x02	-	-	0x14
	NL	NL	NL	ARST	-	-	SPD0
6	0x23	0x23	0x23	0x22	0x18	0x20	0x18
	PL	PL	PL	NL	S-P	T-P	S-P
7	0x21	0x21	0x21	0x21	0x21	0x21	0x21
	EMGS	EMGS	EMGS	EMGS	EMGS	EMGS	EMGS

3

DI	Control mode					
	PR-T	S-T	Communication	PT-PR	PT-PR-S	PT-PR-T
	Default	Default	Default	Default	Default	Default
	Signal	Signal	Signal	Signal	Signal	Signal
1	0x01	0x01	-	0x01	0x01	0x01
	SON	SON	-	SON	SON	SON
2	0x08	-	-	0x04	0x04	0x04
	CTRG	-	-	CCLR	CCLR	CCLR
3	0x11	0x14	-	0x08	0x08	0x08
	POS0	SPD0	-	CTRG	CTRG	CTRG
4	0x12	0x15	0x24	0x11	0x11	0x11
	POS1	SPD1	ORGP	POS0	POS0	POS0
5	0x16	0x16	0x22	0x12	0x24	0x24
	TCM0	TCM0	NL	POS1	ORGP	ORGP
6	0x20	0x19	0x23	0x24	0x18	0x20
	T-P	S-T	PL	ORGP	S-P	T-P
7	0x21	0x21	0x21	0x2B	0x2B	0x2B
	EMGS	EMGS	EMGS	PT-PR	PT-PR	PT-PR

Note:

1. Refer to the C7 and C8 diagrams in Section 3.4.2.3 for wiring.
2. Description of each DI signal:

DI	Description	DI	Description	DI	Description
SON	Servo activated	NL	Negative limit	PL	Positive limit
CCLR	Pulse clear	ARST	Alarm reset	EMGS	Emergency stop
CTRG	Internal position command triggered	TCM0	Torque command 0	TCM1	Torque command 1
TRQLM	Torque limit	SPD0	Speed selection 0	SPD1	Speed selection 1
SPDLM	Speed limit	POS0	Internal position selection 0	POS1	Internal position selection 1
S-P	Switch between S and P modes (dual / multi-mode)	T-P	Switch between T and P modes (dual / multi-mode)	S-T	Switch between S and T modes (dual / multi-mode)
PT-PR	Switch between PT and PR modes (dual / multi-mode)	POS2	Internal position selection 2	ORGP	ORG signal

See the following table for the default DO signal of each control mode:

DO	Control mode						
	PT	PR	S / Sz	T / Tz	PT-S	PT-T	PR-S
	Default	Default	Default	Default	Default	Default	Default
	Signal	Signal	Signal	Signal	Signal	Signal	Signal
1	0x01	0x01	0x01	0x01	0x01	0x01	0x01
	SRDY	SRDY	SRDY	SRDY	SRDY	SRDY	SRDY
2	0x09	0x09	0x03	0x03	0x03	0x03	0x03
	HOME	HOME	ZSPD	ZSPD	ZSPD	ZSPD	ZSPD
3	0x05	0x05	0x04	0x04	0x05	0x05	0x05
	TPOS	TPOS	TSPD	TSPD	TPOS	TPOS	TPOS
4	0x07	0x07	0x07	0x07	0x07	0x07	0x07
	ALRM	ALRM	ALRM	ALRM	ALRM	ALRM	ALRM

DO	Control mode					
	PR-T	S-T	Communication	PT-PR	PT-PR-S	PT-PR-T
	Default	Default	Default	Default	Default	Default
	Signal	Signal	Signal	Signal	Signal	Signal
1	0x01	0x01	0x01	0x01	0x01	0x01
	SRDY	SRDY	SRDY	SRDY	SRDY	SRDY
2	0x03	0x03	-	0x09	0x09	0x09
	ZSPD	ZSPD	-	HOME	HOME	HOME
3	0x05	-	-	0x05	0x05	0x05
	TPOS	-	-	TPOS	TPOS	TPOS
4	0x07	0x07	0x07	0x07	0x07	0x07
	ALRM	ALRM	ALRM	ALRM	ALRM	ALRM

Note: description of each DO signal.

DO	Description	DO	Description	DO	Description
SRDY	Servo ready	HOME	Homing is complete	TSPD	Target speed reached
ZSPD	Zero motor speed	TPOS	Target position reached	ALRM	Servo alarm

If the default DI/DO function cannot meet the application requirement, you can refer to the following tables and specify the DI/DO functions by setting the DI and DO codes to the corresponding parameters.

Signal		CN1 Pin No.	Corresponding parameter	Signal		CN1 Pin No.	Corresponding parameter
Standard DI	DI1-	7	P2.010	Standard DI	DI5-	11	P2.014
	DI2-	8	P2.011		DI6-	12	P2.015
	DI3-	9	P2.012		DI7-	13	P2.016
	DI4-	10	P2.013		-	-	-

Signal		CN1 Pin No.	Corresponding parameter	Signal		CN1 Pin No.	Corresponding parameter
Standard DO	DO1+	1	P2.018	Standard DO	DO3+	25	P2.020
	DO1-	2			DO3-	26	
	DO2+	3	P2.019		DO4+	23	P2.021
	DO2-	4			DO4-	24	

### 3.4.2.2 A3-E and A3-F models – Quick connector

The CN1 quick connector (ACS3-IFSC2616) applicable for the A3-E and A3-F series is designed for easy wiring. You do not need to solder the wires; the spring-loaded terminals prevent the wires from loosening caused by vibration. The connector includes five digital inputs, two digital outputs, and pulse inputs.

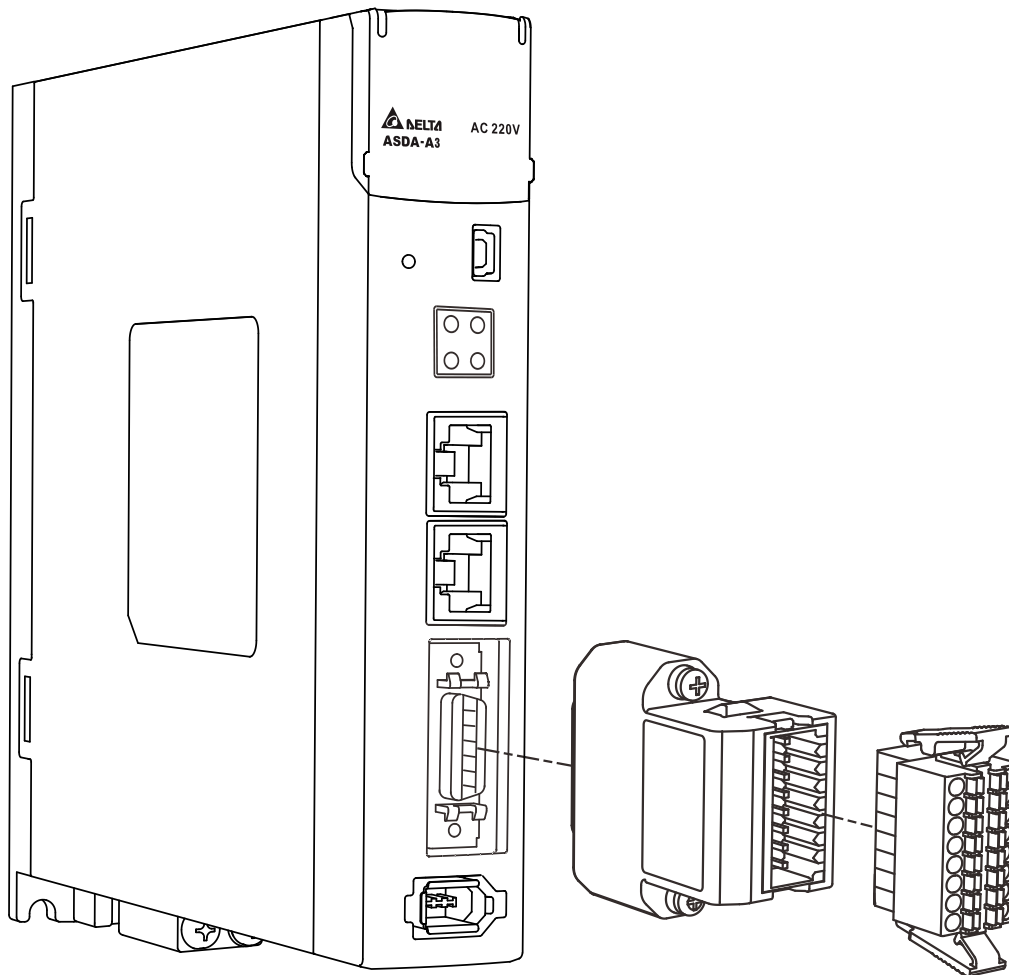



On A3-E and A3-F series models, pin assignments for J2 and J1 of the CN1 quick connector (ACS3-IFSC2616) are as follows:

# 3

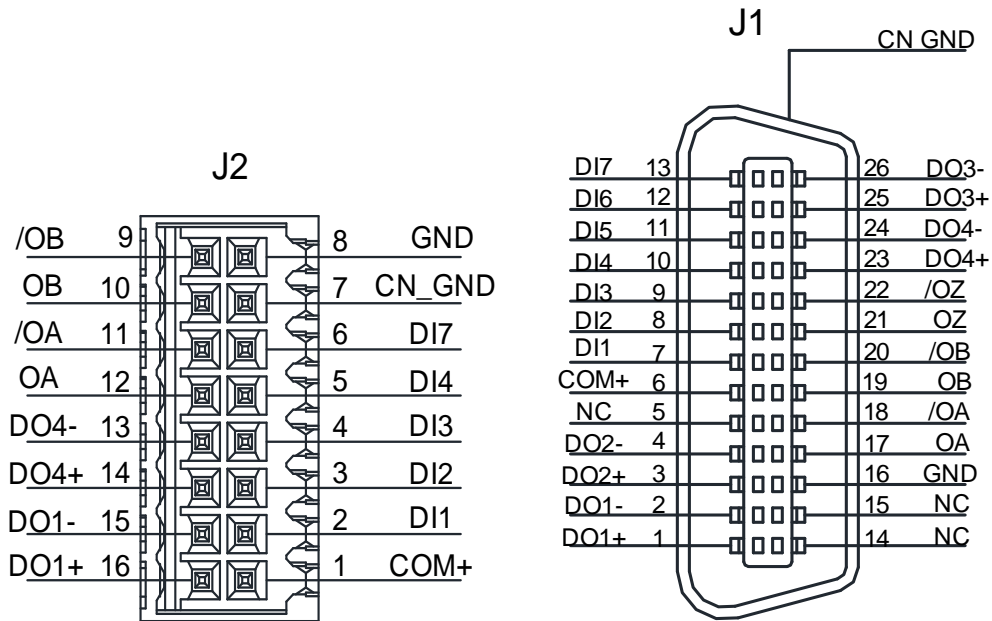

J2-PIN	Signal	J1-PIN
1	COM+	6
2	DI1	7
3	DI2	8
4	DI3	9
5	DI4	10
6	DI7	13
7	CN_GND	-
8	GND	16
9	/OB	20
10	OB	19
11	/OA	18
12	OA	17
13	DO4-	24
14	DO4+	23
15	DO1-	2
16	DO1+	1

Note: refer to Section 3.11 and 3.12 for standard wiring examples.

Wiring and installation for the CN1 quick connector (ACS3-IFSC2616):

**Installation**

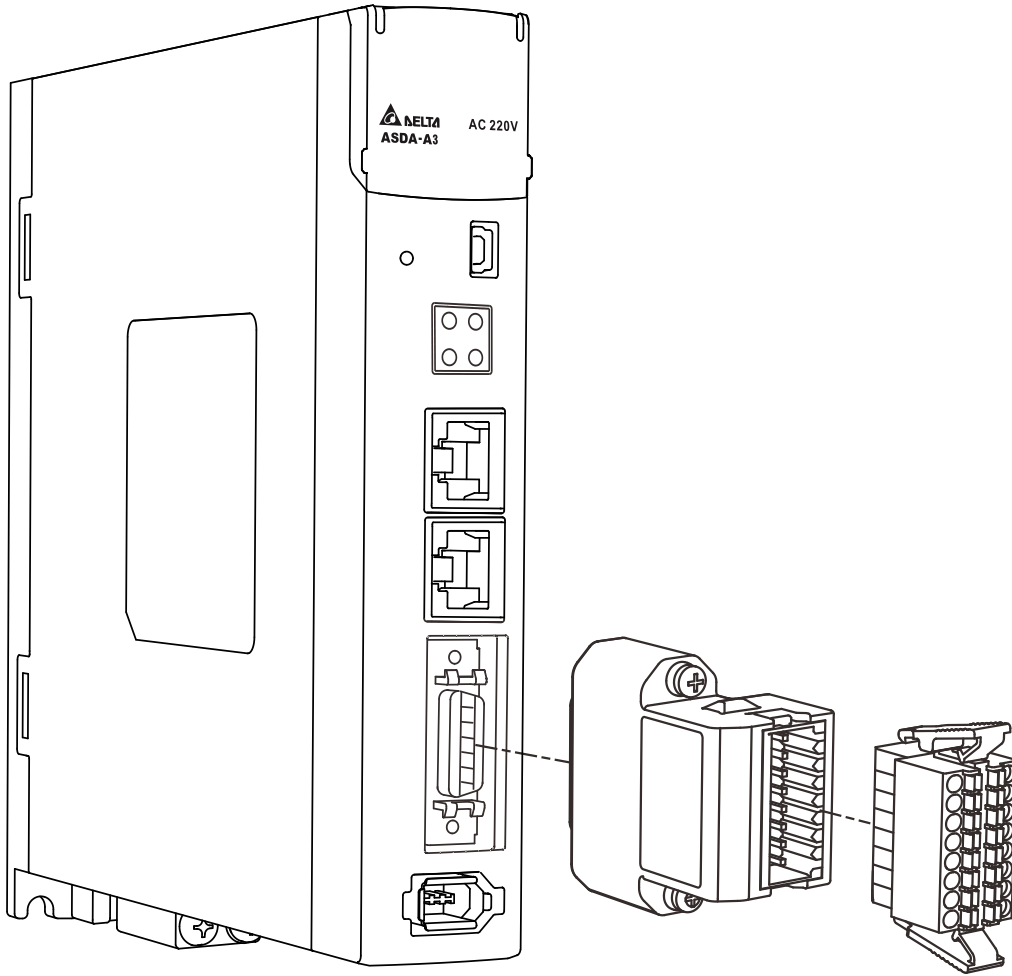

3

## Wiring

3

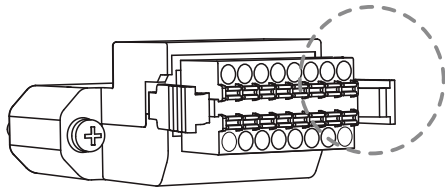

- (1) The CN1 quick connector (ACS3-IFSC2616) has multiple spring-loaded terminals. Determine which terminal is to be wired in advance.

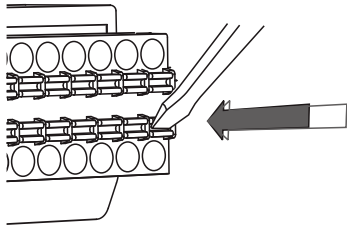

- (2) Use a flathead screwdriver to press the spring down to open the pin.

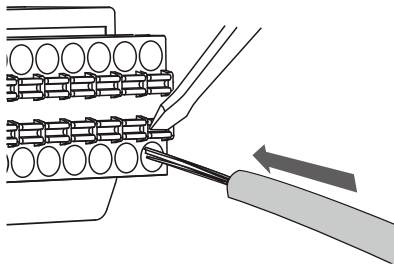

- (3) Insert the stripped wire into the pin.

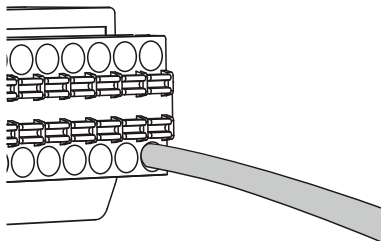

- (4) Withdraw the screwdriver to complete the wiring.

### 3.4.2.3 A3-E and A3-F models – CN1 wiring diagrams

Caution: when the drive connects to an inductive load, you must install the diode.

DO specification:

Permissible current: below 40 mA; surge current: below 100 mA; maximum voltage: 30V.

Diode specification:

1A or above, 500V or above (e.g., 1N4005).

C5: DO wiring - the servo drive uses an external power supply and the resistor is for general load.

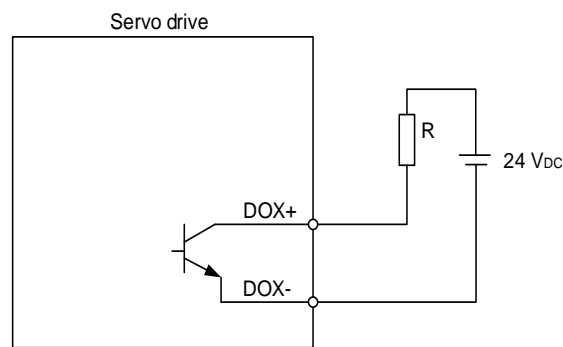

C6: DO wiring - the servo drive uses an external power supply and the resistor is for inductive load.

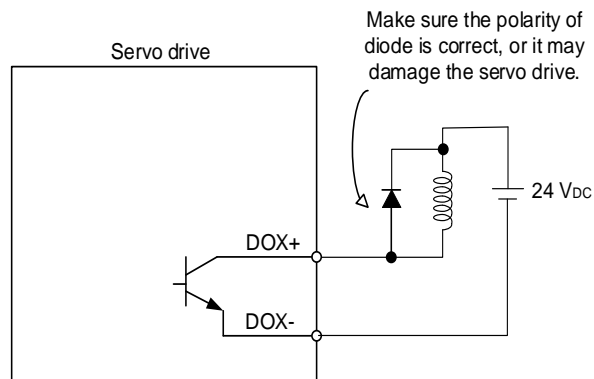

# 3

DI wiring - input signals by relay or open collector transistor.

Conditions of DI On / Off:

ON: 15V - 24V; condition: input current = 8 mA.

OFF: 5V or below; the input current must not be higher than 0.5 mA.

C7: NPN transistor (SINK mode)

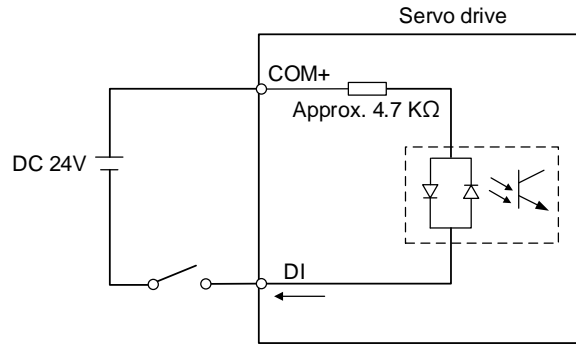

C8: PNP transistor (SOURCE mode)

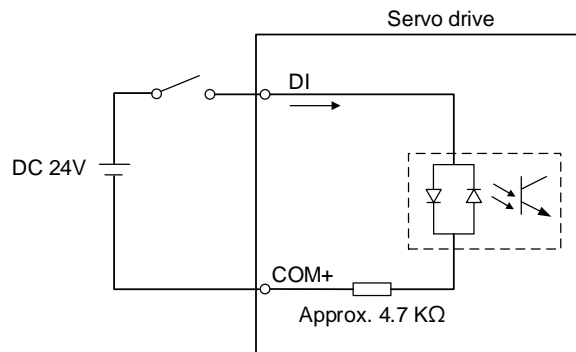

C9: output for encoder position signal (line driver)

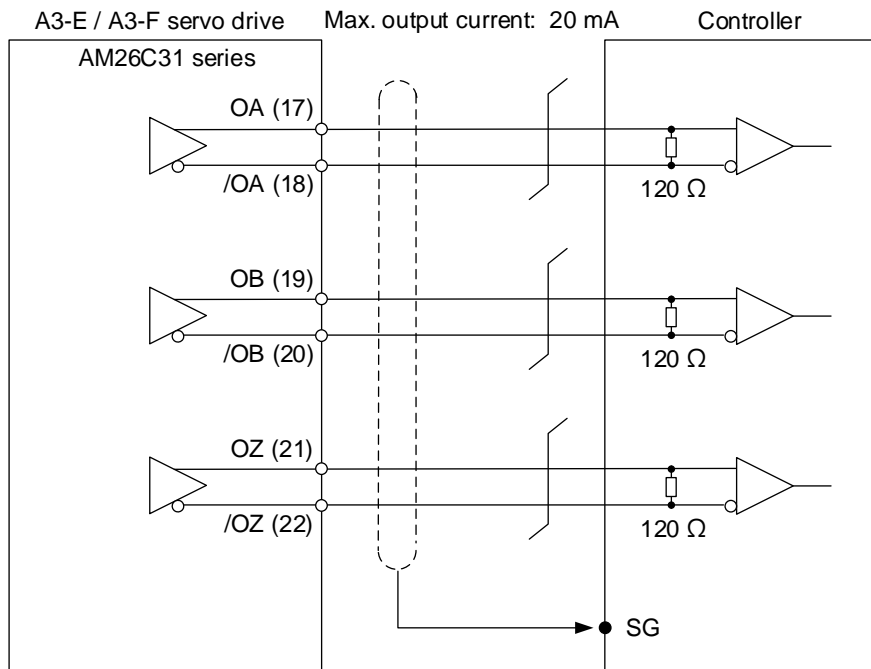

Note: it is suggested that you connect the two GNDs for the controller and servo drive in parallel when the voltage deviation between the controller and the servo drive is too great.

C10: output for encoder position signal (photocoupler)

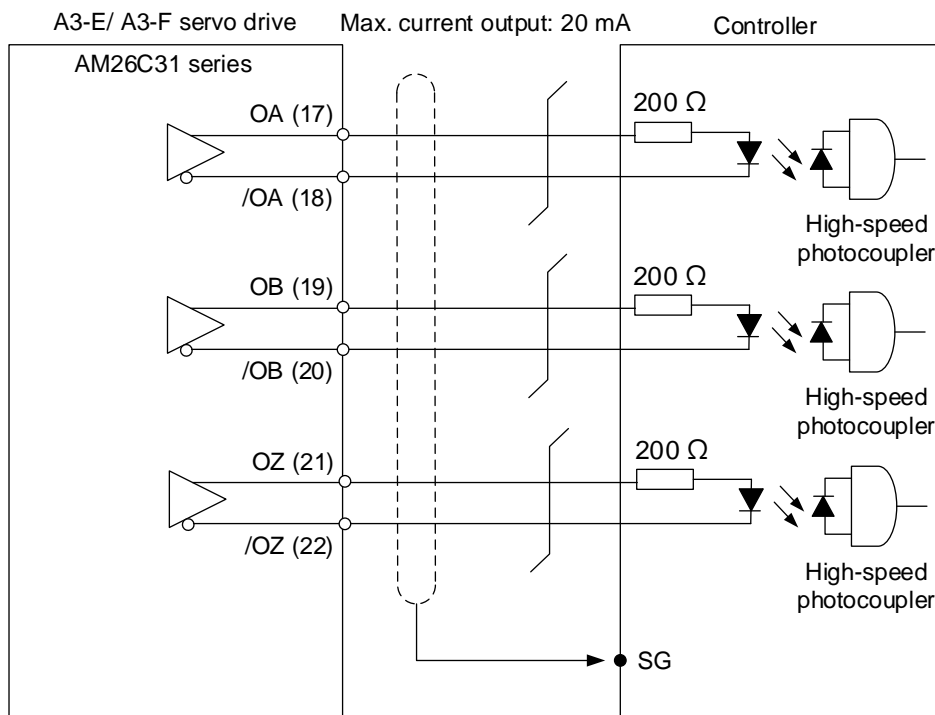

3

### 3.5 Wiring for the CN2 encoder connector

The wiring of the CN2 encoder connector is shown as follows:

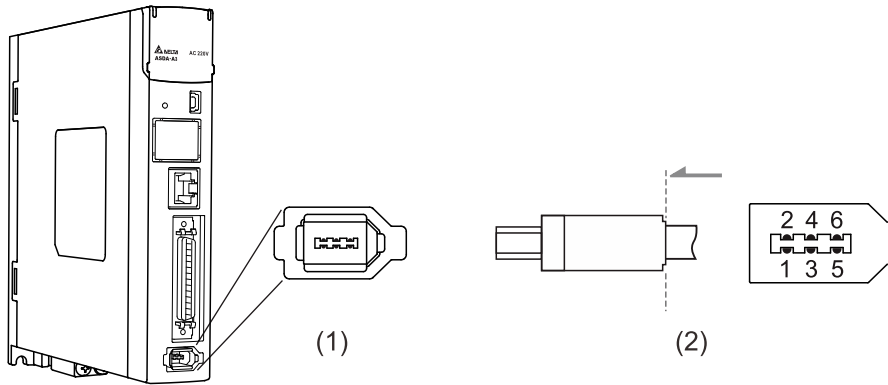

(1) CN2 connector (female); (2) CN2 connector (male)

**■ DO NOT** wire Pin 3 and Pin 4 of the servo drive CN2 connector. These pins are for third-party motors and internal use only\*. Wiring them will cause damage to the internal circuit.

**■** When an absolute encoder is used, the battery supplies power directly to the encoder, so wiring the battery wires to the CN2 connector of the servo drive is not required.

**WARNING**

Note: if you are using a third-party motor supported by ASDA-A3, refer to CH11 Linear Motor and Third-Party Motor for wiring.

Illustration of connector	Recommended brand	Model name
	Delta	ACS3-CNENC200
	JAWS	IES06G7AQB1

Connectors (standard connector / CN2 connector) of the encoder cable  
(for ECM-A3 / B3 F40 to F80 motors):

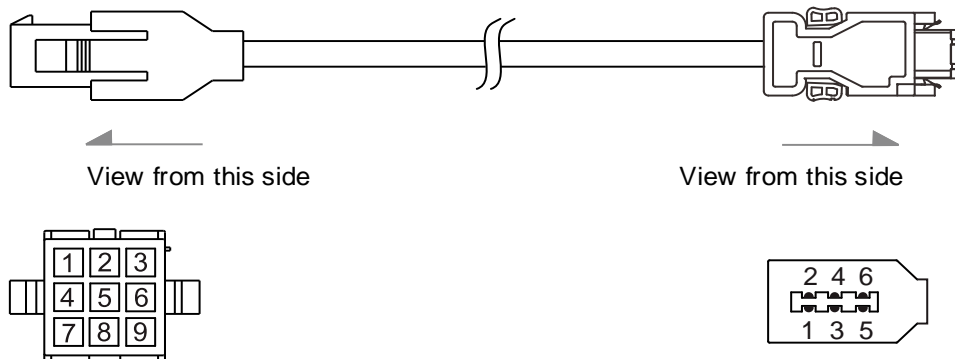

Connectors (military connector / CN2 connector) of the encoder cable  
 (for ECMC F100 to F180 motors):

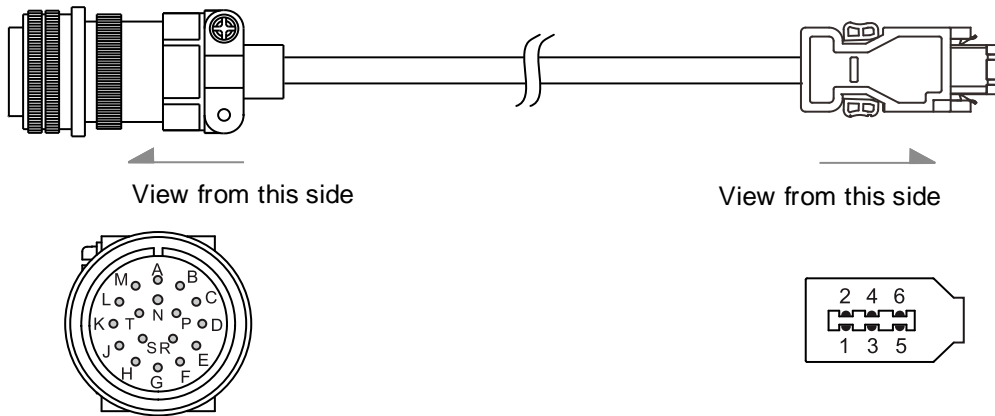

Connectors (military connector / CN2 connector) of the encoder cable  
 (for ECM-B3 F100 to F220 motors):

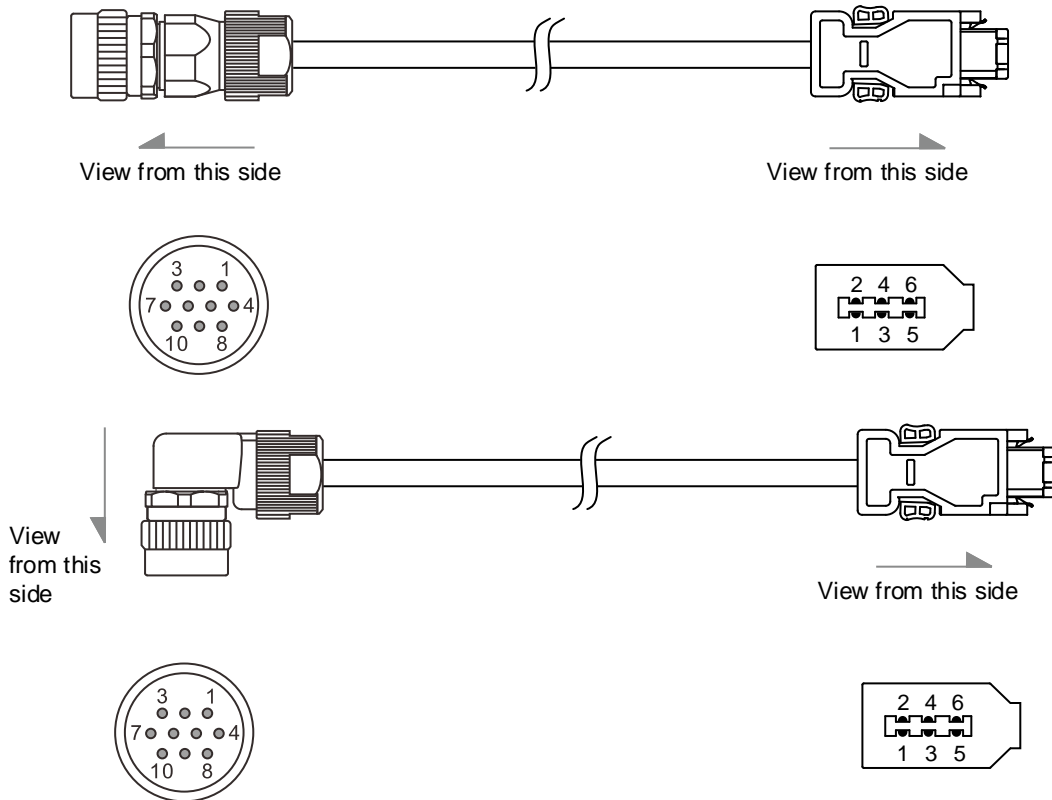



# 3

Connectors (CHOGORI connector / CN2 connector) of the encoder cable  
 (for ECM-A3 / B3 220V F40 to F80 motors):

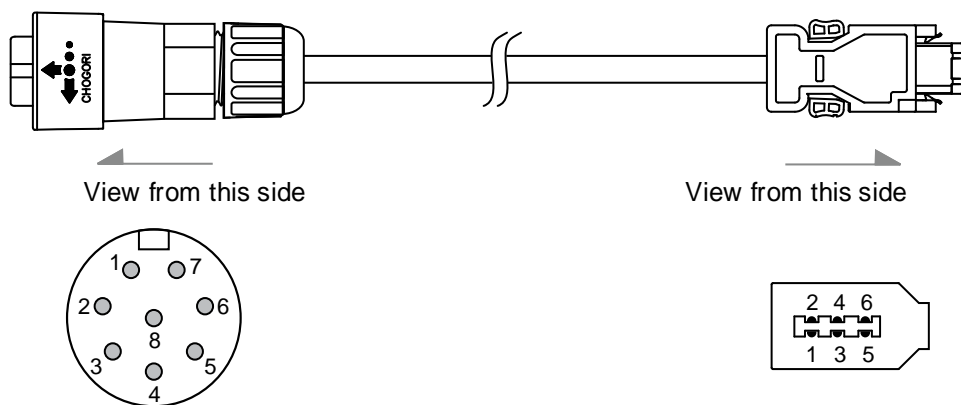

Connectors (bulkhead connector / CN2 connector) of the encoder cable  
 (for ECM-B3 220V F40 to F80 motors):

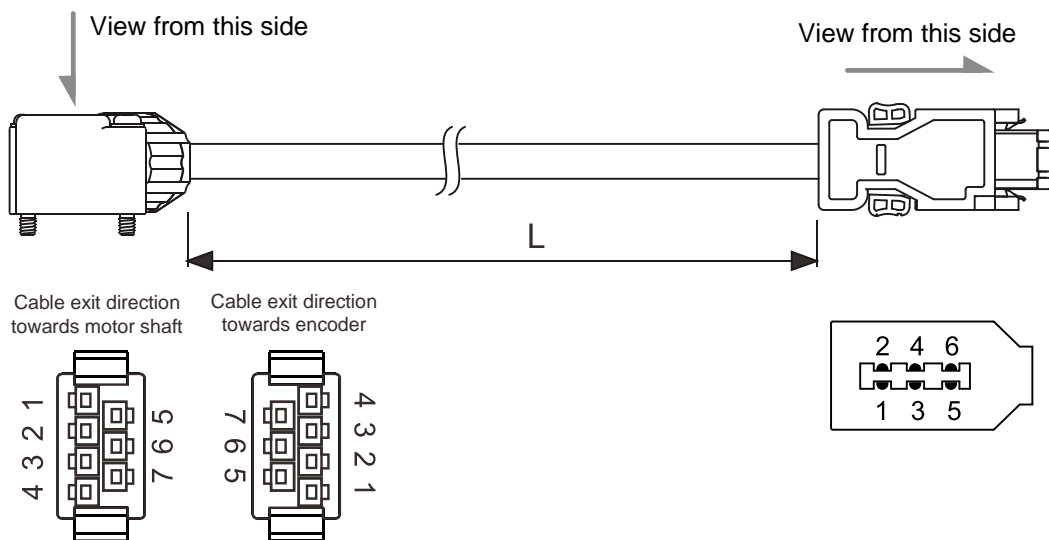

Pin assignment of the connectors:

Encoder cable connector							CN2 of servo drive		Description
Motor with cables				Motor with bulkhead connectors		Pin No.	Signal		
ECMC military	B3 military	CHOGORI	Standard	Color	Bulkhead			Color	
S	4	4	7	Brown	3	Red	1	+5V	+5V power supply
R	9	3	8	Blue	4	Orange	2	GND	Power ground
-	-	-	-	-	-	-	3	CLOCK+	<b>DO NOT connect these pins. They are for third-party motors and internal use only.</b>
-	-	-	-	-	-	-	4	CLOCK-	
A	1	1	1	White	1	Blue	5	T+	Serial communication signal (+)
B	2	2	4	White/Red	2	Purple	6	T-	Serial communication signal (-)
L	10	8	9	-	7	-	Case	Shielding	Shielding
C	6	6	2	Red	5	Brown	-	-	+3.6V battery
D	5	5	5	Black	6	Black	-	-	Battery ground

Note:

1. For the wiring details of the absolute encoder connectors, refer to Section 3.1.5 Encoder cable and connector specifications.
2. Pin 3 and Pin 4 of the servo drive CN2 connector are for third-party motors and internal use only. Refer to Section 11.2.3.3 Pin assignment of communication type motors.

3

3

Connect the shielded wires to the CN2 connector as follows:

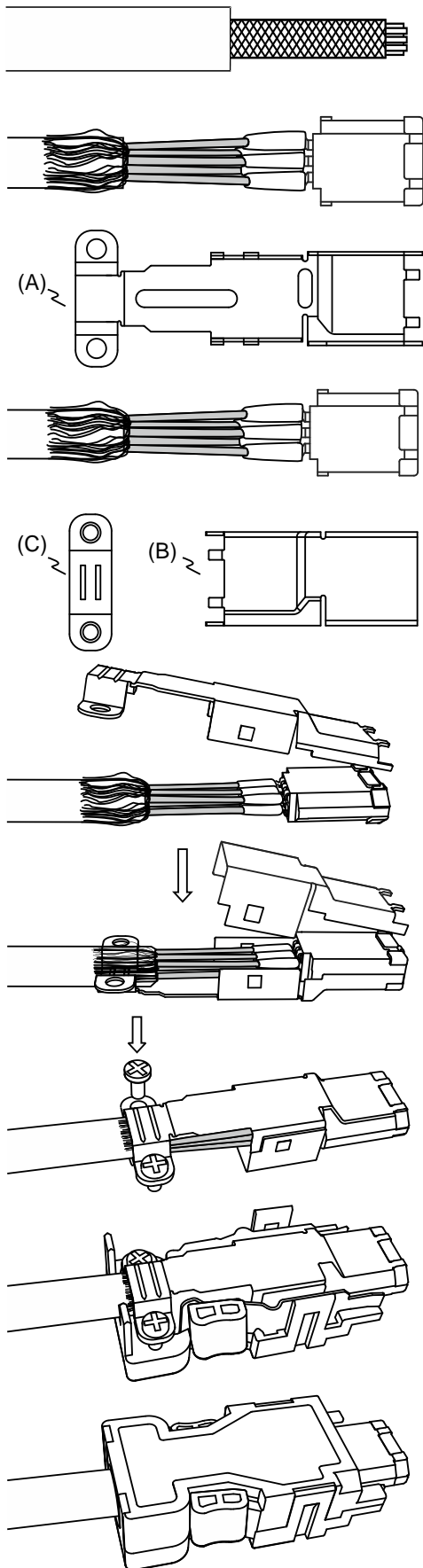

Step 1:

Strip the cable and expose the wires covered by the metal shield. The exposed wire length should be 20 - 30 mm (0.79 - 1.18 inches).

Step 2:

Spread the metal shield and fold it back. Refer to the pin assignment in the preceding table to connect the wires.

Step 3:

You need the following items to assemble the connector:

- (A) Big metal case
- (B) Small metal case
- (C) U-shaped bracket

Step 4:

Place the big metal case to cover the exposed metal shield. Make sure the metal shield is completely covered to maintain the integrity of the shielding.

Step 5:

Fasten the small metal case on the other side.

Step 6:

Place the U-shaped bracket over the big metal case and fasten them with screws.

Step 7:

Fit one side of the plastic case over the connector.

Step 8:

Place and fasten the other side of the case to complete assembling the connector.

### 3.6 Wiring for the CN3 connector (RS-485 / high-speed communication)

When the servo drive is connected to the PC via the CN3 connector, you can operate the servo drive, PLC, or HMI through Modbus using the assembly language. The CN3 connector supports two commonly used communication interfaces, RS-485 and CAN, allowing you to connect multiple servo drives simultaneously.

Note:

1. A3-L: single port (Pin 1 - Pin 8); supports RS-485 but does not support high-speed communication (CANopen).
2. A3-M: dual ports; support both RS-485 and high-speed communication (CANopen).

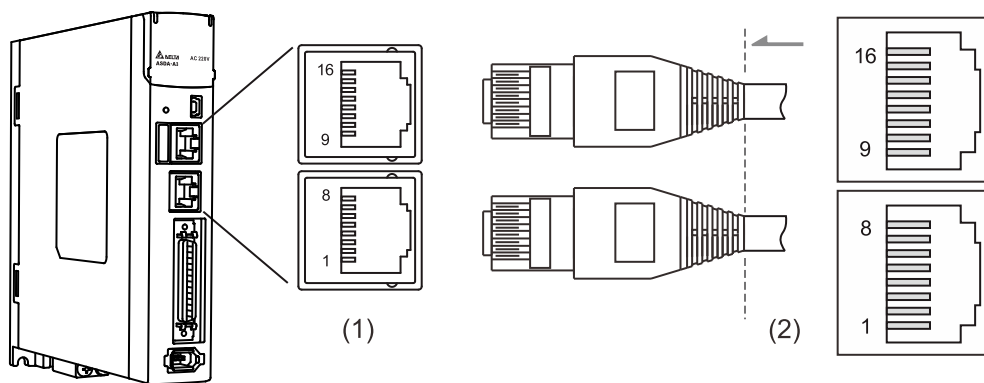

(1) CN3 connector (female); (2) CN3 connector (male)

Pin assignment:

Pin No.	Signal	Description
1	CAN_H	CAN_H bus line (dominant high)
2	CAN_L	CAN_L bus line (dominant low)
3, 7	GND_ISO	Signal GND
4	RS-485-	For the servo drive to transmit the data to differential terminal (-).
5	RS-485+	For the servo drive to transmit the data to differential terminal (+).
6, 8	-	Reserved
9	CAN_H	CAN_H bus line (dominant high)
10	CAN_L	CAN_L bus line (dominant low)
11, 15	GND_ISO	Signal GND
12	RS-485-	For the servo drive to transmit the data to differential terminal (-).
13	RS-485+	For the servo drive to transmit the data to differential terminal (+).
14, 16	-	Reserved

Note: refer to Chapter 9 for the RS-485 wiring.

# 3

Connecting multiple servo drives:

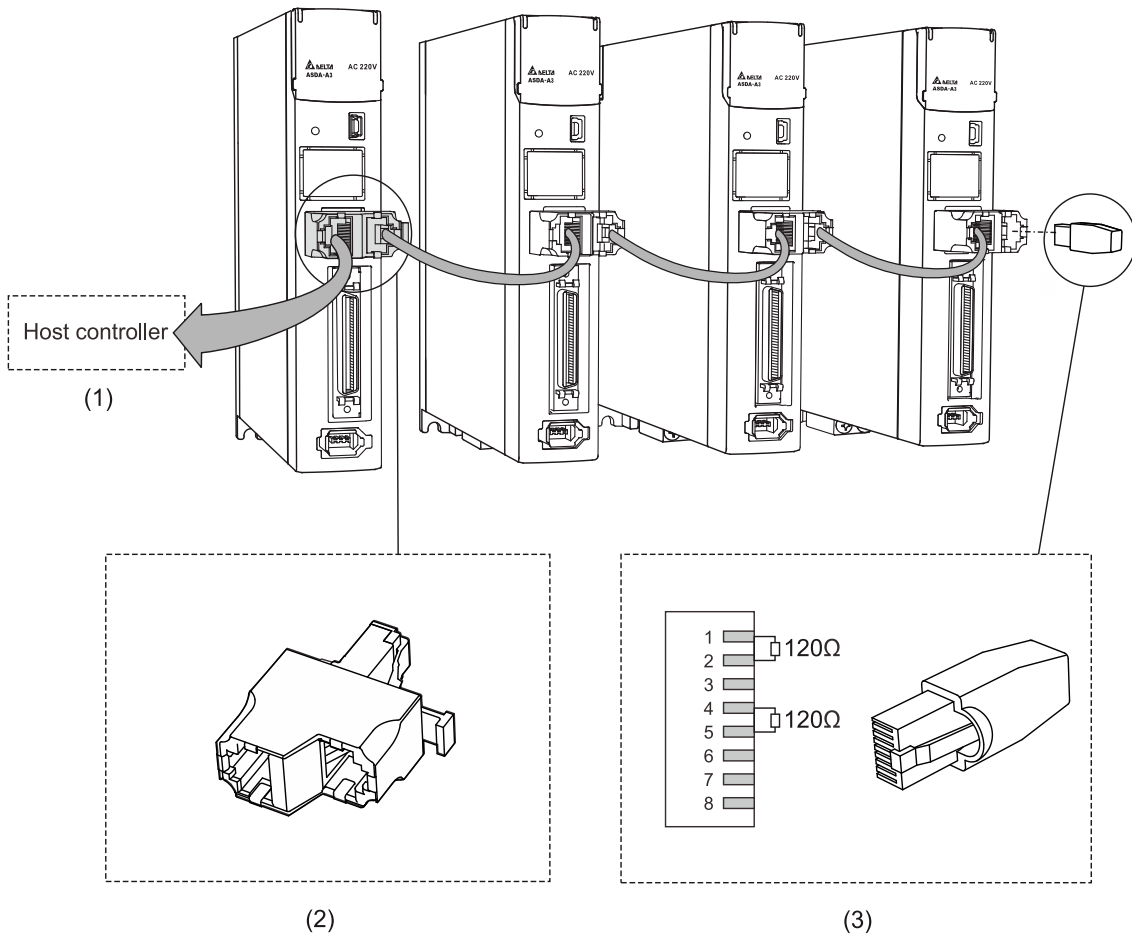

(1) Connect to the controller / PLC; (2) Modbus connector;  
 (3) Wiring for CAN / RS-485 terminal resistor

**Note:**

1. You can connect up to 32 axes through RS-485; CANopen cable length can be up to 30 m (98.43 ft).  
 The communication quality and the number of connectable axes are determined by the controller's specifications, quality of wires, grounding, interference, and whether a shielded twisted-pair cable is used.
2. It is suggested that you use a terminal resistor of 120 Ω (Ohm) and 0.5 W (or more).
3. Connect multiple servo drives in parallel through the two ports of the CAN / RS-485 connector and put the terminal resistor in the last servo drive.

### 3.7 Wiring for CN4 connector (Mini USB)

CN4 is a serial communication port that connects the servo drive to a PC, allowing you to operate the servo drive with the software.

This is a Type B Mini-USB connector that is compatible with the USB 2.0 specification, and installing the USB isolator (Delta model number: UC-ADP01-A) is required.

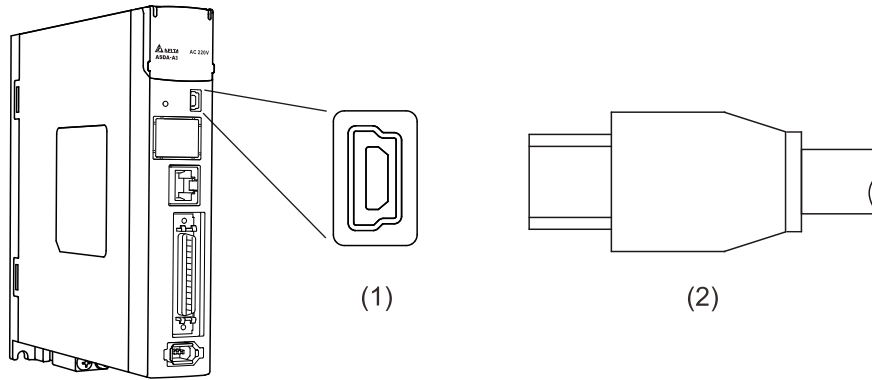

(1) Mini USB connector (female); (2) Mini USB connector (male)

### 3.8 Wiring for CN5 connector (applicable to full-closed loop)

The CN5 connector is for connecting to the external linear scale or the encoder (A, B, and Z), which forms a full-closed loop with the servo system.

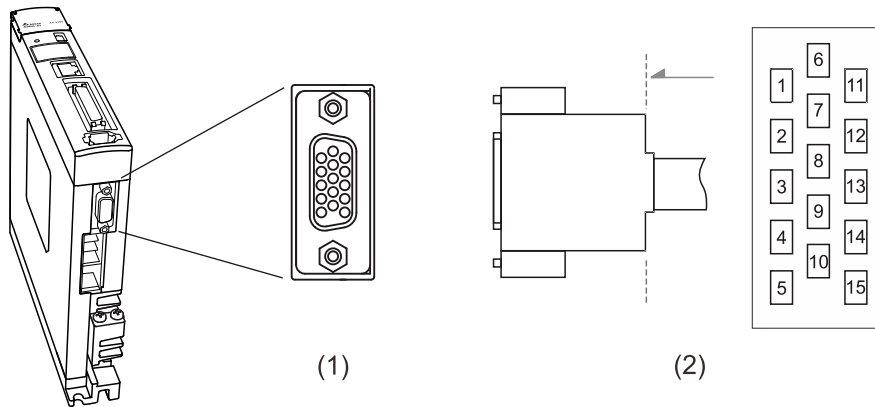

(1) CN5 connector (female); (2) CN5 connector (male)

Note: the tightening torque of the CN5 connector is 2 - 2.5 kgf-cm (1.7 - 2.2 lbf-in).

Pin assignment:

Pin No.	Signal	Description
1	Opt_/Z	/Z phase input
2	Opt_/B	/B phase input
3	Opt_B	B phase input
4	Opt_A	A phase input
5	Opt_/A	/A phase input
6	GND	Ground for the encoder and Hall sensor
7	GND	Ground for the encoder and Hall sensor
8	+5V	Encoder power
9	Opt_Z	Z phase input
10	HALL_U	Hall sensor U phase input
11	HALL_V	Hall sensor V phase input
12	HALL_W	Hall sensor W phase input
13	TEMP+	Motor temperature detection
14	TEMP-	Motor temperature detection
15	-	Reserved
Case	Shielding	Shielding

Note: the motor temperature detection supports using NTC type and PTC type sensors. Refer to Chapter 8 for detailed parameter settings of PM.022 and PM.024.

Specifications and wiring descriptions for the CN5 signals:

Signal type	Hall sensor	A, B, Z phase signal
Operating voltage	5V	5V
Signal format	Single-ended	Differential
Encoder power (5V) output	≤ 300 mA	≤ 300 mA
Pull-up resistor (R)	≤ 20 kΩ <sup>1</sup>	-
Max. pulse frequency	5 kHz	Single-phase pulse frequency: 4 MHz
V <sub>HALL</sub> voltage	High-level voltage > 3.2V (Min.) Low-level voltage < 2.2V (Max.)	-

Note:

1. If the servo drives are manufactured before week 50 of year 2017 (serial numbers: before T1750 and W1750), they only support Hall sensors with built-in pull-up resistors. If there is no built-in pull-up resistors, you need to connect to external ones.
2. If the servo drives are manufactured in week 50 of year 2017 or later (serial numbers: T1750 and W1750, or later), the servo drives support Hall sensors with or without built-in pull-up resistors.

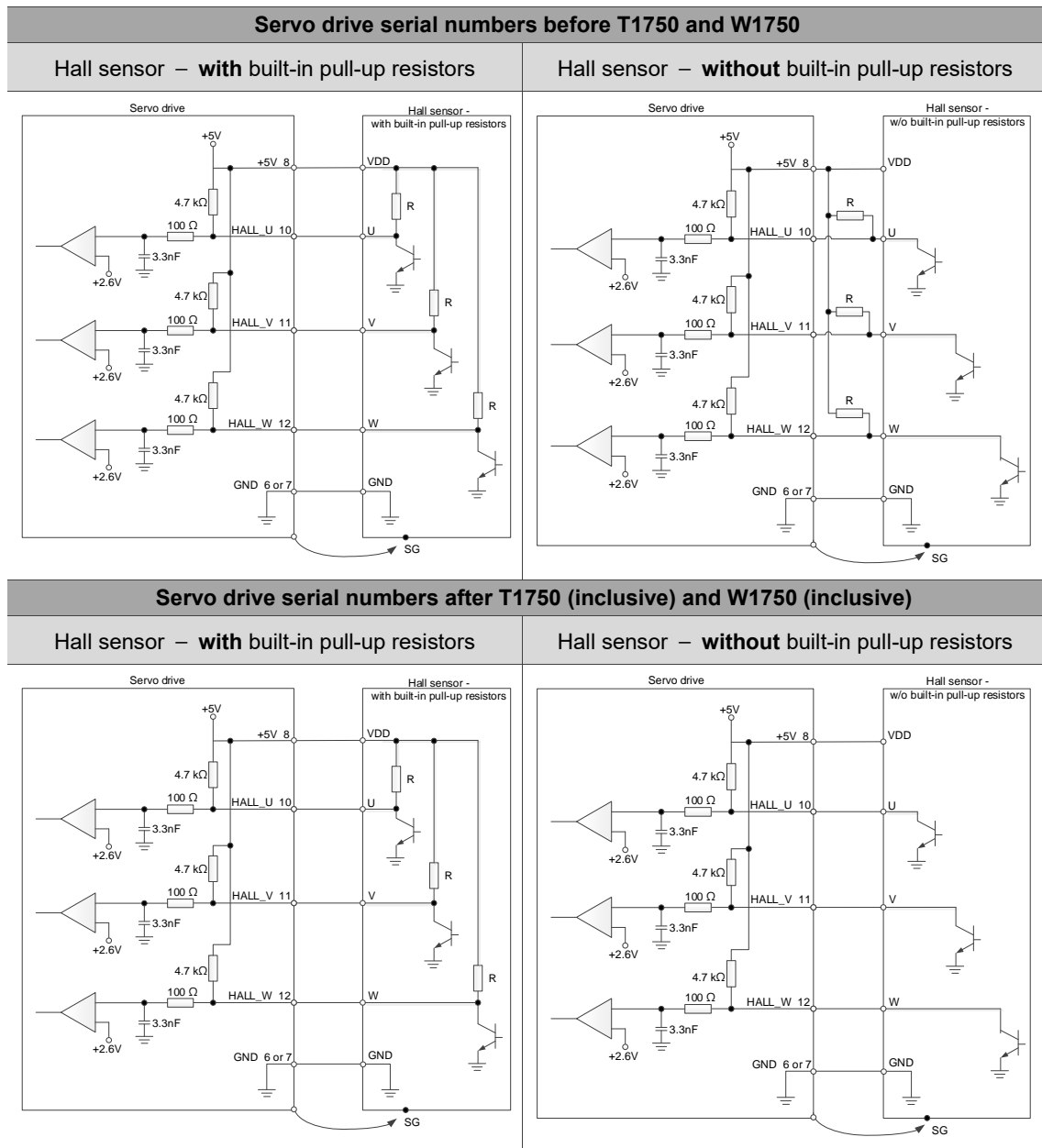



## 3

### 3.9 Wiring for CN6 connector

#### 3.9.1 Wiring for the DMCNET communication connector

The servo drive uses a standard RJ45 connector with a shielded network cable to connect to the controller or motion control card. With Delta's DMCNET system, you can control the position, torque, and speed of the motor, as well as accessing or monitoring the servo status.

Set the station number for the DMCNET system with P3.000. The maximum transmission rate is 20 Mbps. The servo drive provides two DMCNET ports for connecting multiple servo drives, with one way in and the other way out. Remember to put the terminal resistor that comes with the accessory kit of the controller or motion control card in the last servo drive.

Note: DMCNET is supported by the A3-F models only.

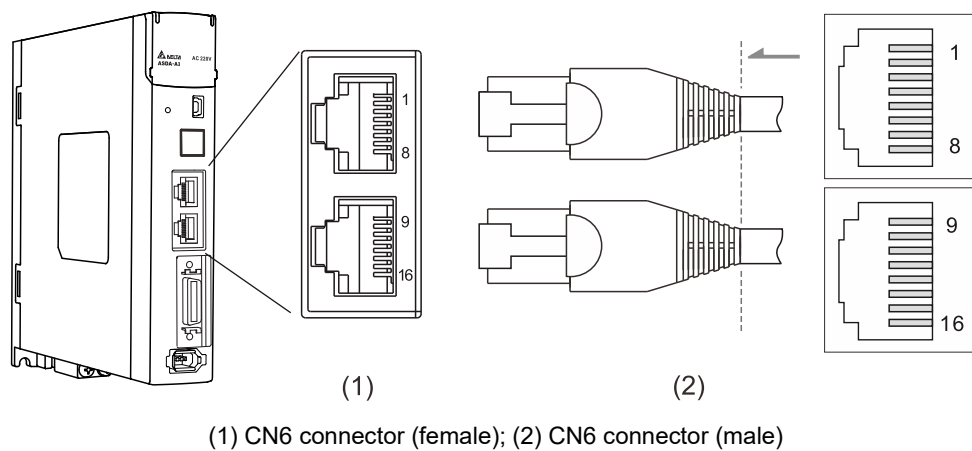

Pin assignment:

Pin No.	Signal	Description
1, 9	DMCNET_1A	DMCNET Channel 1 bus line (+)
2, 10	DMCNET_1B	DMCNET Channel 1 bus line (-)
3, 11	DMCNET_2A	DMCNET Channel 2 bus line (+)
4, 12 5, 13	-	Reserved
6, 14	DMCNET_2B	DMCNET Channel 2 bus line (-)
7, 15 8, 16	-	Reserved

Connecting multiple servo drives:

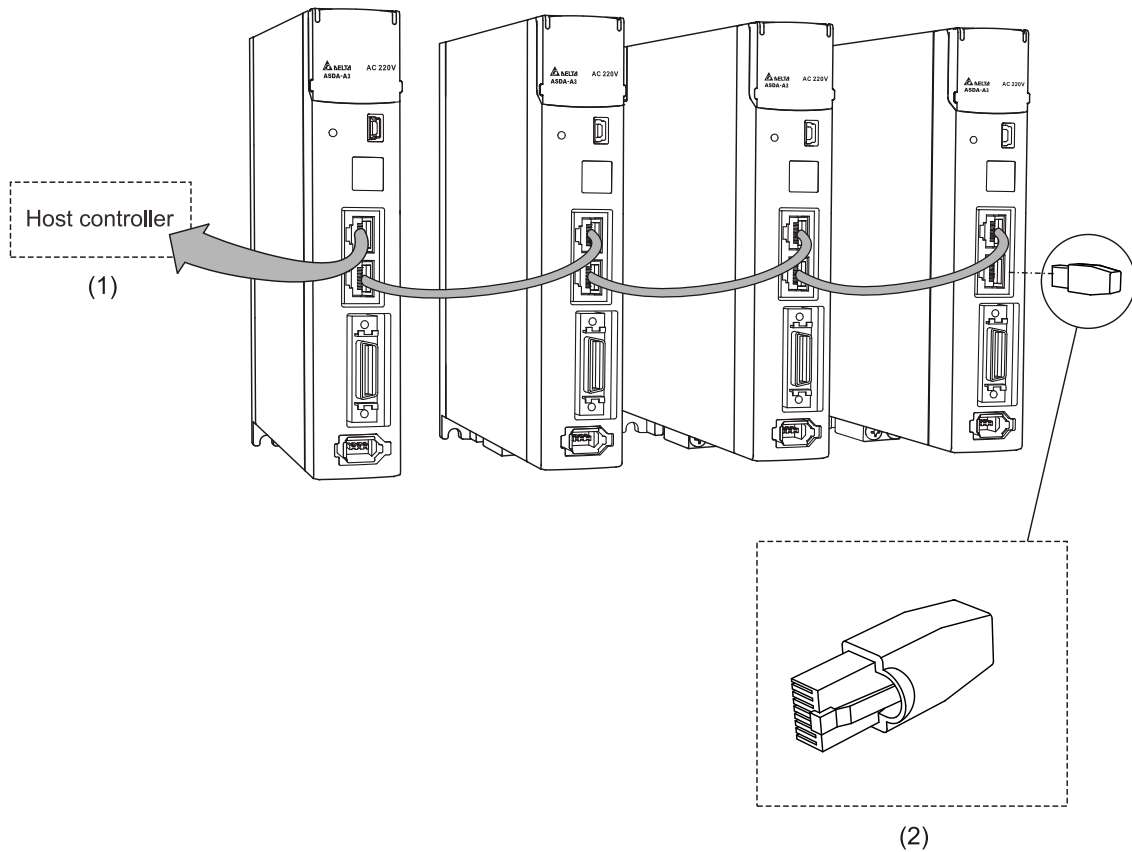

(1) Connect to the controller / motion control card; (2) Illustration of DMCNET terminal resistor

Note:

1. You can connect up to 12 axes through DMCNET communication with the cable length up to 30 m (98.43 ft).
2. You can connect multiple servo drives through the two DMCNET ports with one way in and the other way out, and then put the terminal resistor in the last servo drive.
3. The required resistance value of the terminal resistor depends on the specification of the controller or motion control card. Contact the Customer Service Center of the controller or motion control card for details.

3

### 3.9.2 Wiring for the EtherCAT communication connector

The servo drive provides two EtherCAT ports for connecting multiple servo drives, with one way in and the other way out.

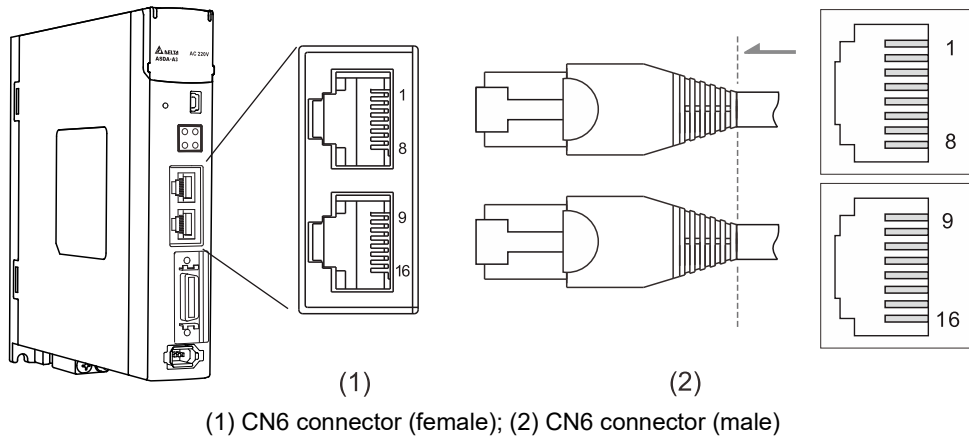

Pin assignment:

Transmission port	Pin No.	Terminal	Signal	Description
IN	1	TX+	TX+	Transmit +
	2	TX-	TX-	Transmit -
	3	RX+	RX+	Receive +
	4	-	-	Reserved
	5	-	-	Reserved
	6	RX-	RX-	Receive -
	7	-	-	Reserved
	8	-	-	Reserved
OUT	9	TX+	TX+	Transmit +
	10	TX-	TX-	Transmit -
	11	RX+	RX+	Receive +
	12	-	-	Reserved
	13	-	-	Reserved
	14	RX-	RX-	Receive -
	15	-	-	Reserved
	16	-	-	Reserved

Note: the IN port is for connecting the controller or the previous servo drive, and the OUT port is for connecting the next servo drive or not connecting to other devices. Incorrect wiring will lead to communication error.

Description of each indicator for the CN6 connector:

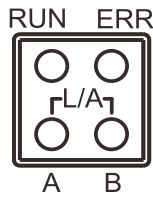

■ LED indicator status description

Indicator	Description
On	<p>ON </p> <p>OFF</p>
Blinking	<p>ON </p> <p>OFF</p>
Single flash	<p>ON </p> <p>OFF</p>
Off	<p>ON</p> <p>OFF </p>

■ Network status indicator (L/A)

Indicator	Status	Description
On	Network is connected	Network connection is established but no data transmission.
Blinking	Network connection is established and data is in transmission	Data in transmission.
Off	No connection	Network connection is not established.

■ EtherCAT connection status indicator (RUN)

Indicator	Status	Description
Off	Initial	After power cycling and the initialization of the servo drive is complete, the communication has not yet started, but the controller can access the servo drive's register.
On	Operational	SDO, TxPDO, and RxPDO data packets can be transmitted.
Blinking	Pre-Operational	The controller can exchange data through the mailbox.
Single flash	Safe-Operational	The servo drive can use the SDO and TxPDO data packets to exchange data with the controller.

■ EtherCAT error indicator (ERR)

Indicator	Status	Description
Off	No error	No error has occurred.
On	PDI Watchdog timeout	Servo drive malfunction. Contact the distributor for assistance.
Blinking	State change error	Parameter setting error causes the system unable to switch the state. Refer to the following diagram.
Single flash	Synchronization error / SyncManager error	The synchronization between the controller and the servo drive failed or the data was lost during data reception.

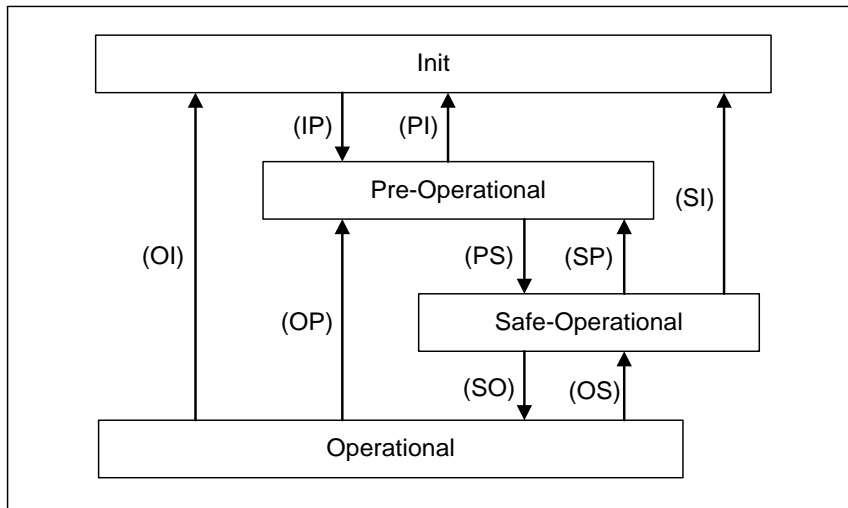
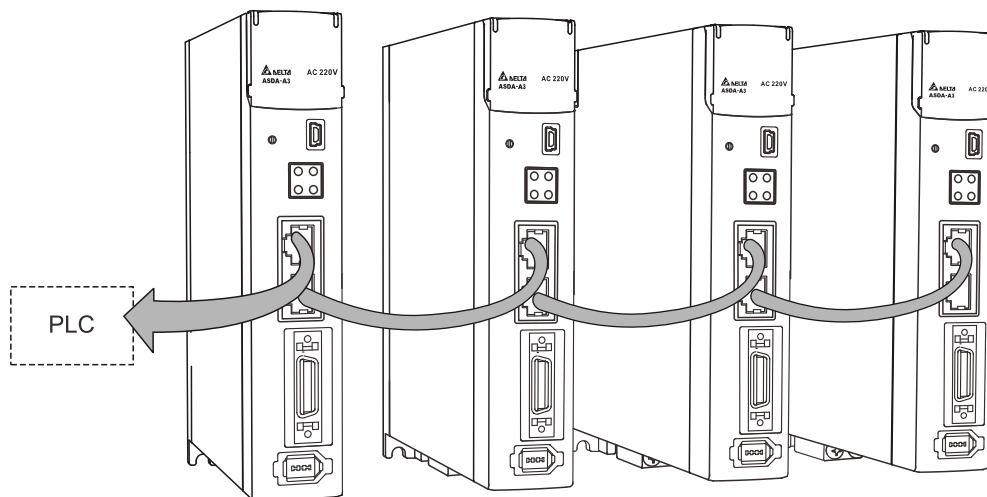

Figure 3.9.2.1 EtherCAT State Machine

Connecting multiple servo drives:



Note:

1. When multiple servo drives are connected, the maximum distance between each servo drive is 50 m (164.04 inches).
2. Use CAT5e STP cable.
3. It is suggested that you use a Beckhoff network cable (model number: ZB9020).
4. Ensure the wiring is correct. The IN port is for connecting the controller or the previous servo drive, and the OUT port is only for connecting the next servo drive.

## 3.10 CN10 STO (Safe Torque Off) function

### 3.10.1 Introduction to STO

The STO function stops the current to the motor immediately. The dual-channel input signals (SF1 and SF2 signals) stop the servo drive from supplying power to the motor.

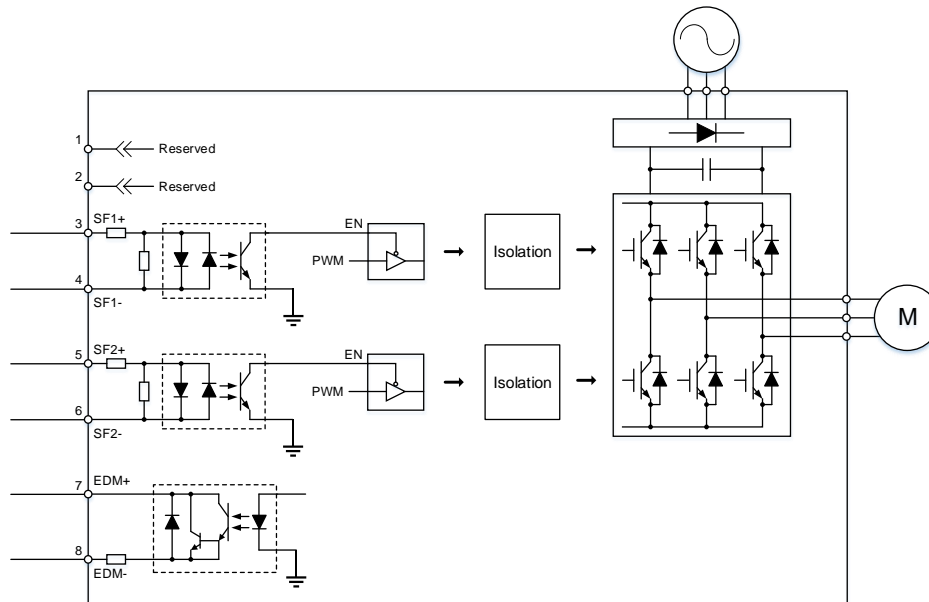

Note:

1. STO certification application for the 220V series models is in progress.
2. For this servo drive, the safe state is defined as "the state that power supply to the motor is cut off". If an error or danger is diagnosed, take the measure to have the servo drive enter the safe state.

### 3.10.2 Precautions for using STO function

Read the following safety precautions carefully to ensure system safety.

- Only qualified personnel fully understanding the safety standards can design, install, and operate the system after reading this operation manual.
- Use products with safety certifications or machines compliant with safety specifications to build a safe electrical circuit.
- Before installation and wiring, read the operation manuals of all the peripheral devices carefully.
- If the motor is moved by external forces when the STO function is activated, take safety measures such as using the mechanical brake.
- Evaluate the risk of using the machine or the connecting devices.

### 3.10.3 Potential risks of STO

After the STO function is activated, the servo drive can no longer control the motor. Hence, you must evaluate all the potential risks that may result from the activation of the STO function to ensure safety. Delta is not liable for any mechanical damage and personnel injury caused by the potential risks.

- Do not touch the servo drive after activating the STO function. The STO function stops the servo drive from supplying power to the motor but does not cut off the power to the servo drive. Thus, there is a potential risk of electric shock.  
When maintaining the servo drive, use the molded-case circuit breaker (MCCB) or magnetic contactor (MC) to cut off the power to the servo drive.
- When the STO function is activated, the servo drive can no longer stop or decelerate the motor.
- The STO function cuts off the power to the motor, but the motor can still be moved by other external forces.
- When installing the machine or changing the servo drive, ensure to check if the STO function works normally.
- The motor may move due to malfunction of the power device, and the maximum moving range is 180 electrical degrees.
- Supply power to the STO input signals with a single power source. If you use a split power supply, the leakage current may result in STO misoperation. In addition, the STO function must be powered by the safety extra-low voltage (SELV) power source with reinforced insulation.
- The EDM output signals are not safety output signals, which are used only for failure monitoring. Incorrect use of the EDM signals may result in personnel injury. When an STO failure is detected with the EDM signals, keep the STO input signals off.
- To avoid malfunction caused by accumulated errors, you must check the safety functions at least once every 3 months.

### 3.10.4 Safety parameters

To comply with the EN ISO 13849-1 PL e and IEC 61508 SIL3 standards, you have to monitor the EDM signals with the controller. If you do not monitor the EDM signals, the system only meets the IEC 61508 SIL2 standard. Refer to the following tables for the related standards.

Overseas specification	Standard
Machinery Directive	IEC / EN 61508: 2010
	EN IEC 62061:2021
	IEC 61800-5-2: 2016 / EN 61800-5-2: 2017
	EN ISO 13849-1: 2015
EMC Directive (Functional safety)	IEC / EN 61326-3-1: 2017
	IEC 61000-6-7: 2014 / EN 61000-6-7: 2015

Item	Description	Standard	EDM signal monitoring with controller	No EDM signal monitoring
Safety function	Safety function	IEC / EN 61800-5-2	STO	STO
HFT	Hardware fault tolerance	IEC / EN 61508	1	1
Subsystem	Subsystem	IEC / EN 61508	Type A	Type A
SIL	Safety integrity level	IEC / EN 61508	SIL3	SIL2
		EN IEC 62061	maximum SIL3	maximum SIL2
PFH	Probability of dangerous failure per hour [h <sup>-1</sup> ]	IEC / EN 61508 EN IEC 62061	1.61x10 <sup>-9</sup> [1/h] (1.61% of SIL3)	1.66x10 <sup>-9</sup> [1/h] (0.166% of SIL2)
Response time	Response time	IEC / EN 61508	≤ 10 ms	≤ 10 ms
Category	Category	EN ISO13849-1: 2015	Category 3	Category 3
PL	Performance level	EN ISO13849-1: 2015	PL e	PL d
MTTF <sub>d</sub>	Mean time to dangerous failure	EN ISO13849-1: 2015	High	High
DC	Diagnostic coverage	EN ISO13849-1: 2015	Medium	Low
Mission time	Mission time	EN ISO13849-1: 2015	20 years	20 years



3

### 3.10.5 How does the STO function work?

The STO function controls the motor current by two individual circuits. When the STO function is activated, it cuts off the power to the motor, so the motor is free from torque force. The following table details how this function works.

Signal		Status of opto-isolator			
STO	SF1+ SF1-	ON	ON	OFF	OFF
	SF2+ SF2-	ON	OFF	ON	OFF
Servo drive output status		Ready	Torque off (SF2 lost)	Torque off (SF1 lost)	Torque off (STO activated)
Diagnostic output (EDM)		OFF	OFF	OFF	ON
Alarm		N/A	AL502	AL501	AL500

Note:

1. AL500 is triggered only when P1.120 is set to 1 or 3.
2. Definition of STO signal status: ON = 24V; OFF = 0V.
3. Definition of EDM signal status: OFF = open (open circuit); ON = close (closed circuit).
4. The status of the EDM signals changes at once according to the status of the safety signals (SF1 and SF2 signals).

#### 3.10.5.1 Response time

When either SF1 signal or SF2 signal becomes OFF, the circuit cuts off the current to the motor within 10 ms.

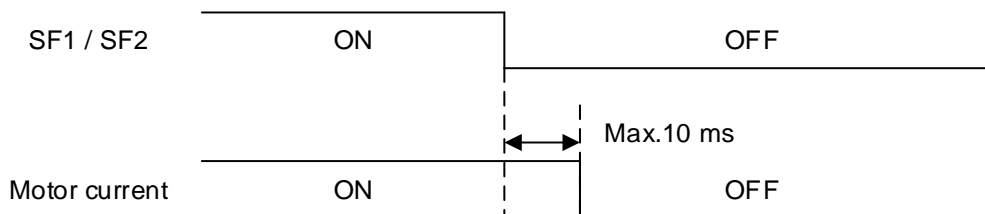

### 3.10.5.2 Alarm triggering

#### (1) AL500 (STO function is activated)

When either SF1 signal or SF2 signal becomes OFF, the STO function is activated, the circuit cuts off the current to the motor within 10 ms, and the servo drive is Off, triggering AL500.

When both SF1 and SF2 signals become OFF, the servo drive still displays AL500. Refer to the following diagram.

The panel displays either "AL500" or "-STO-" according to the setting of P1.120.

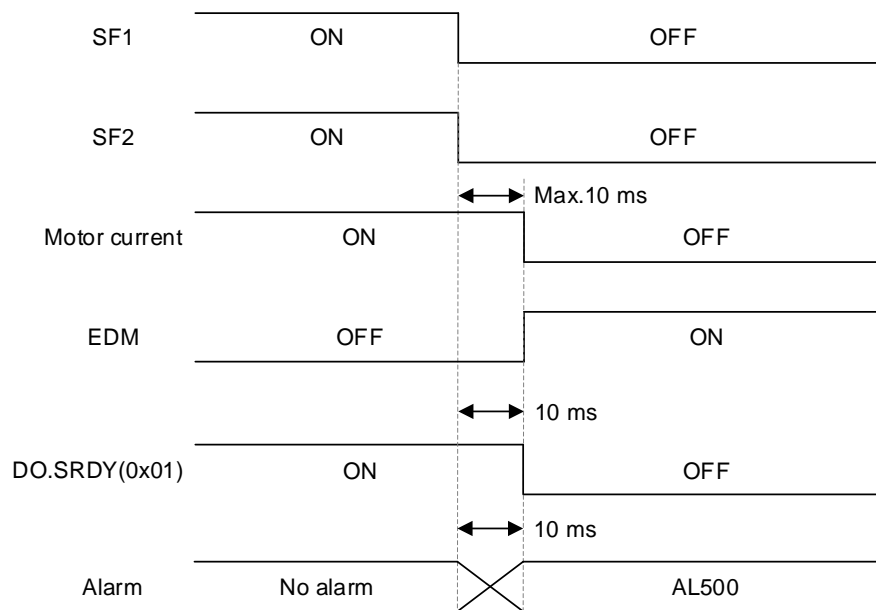

3

(2) AL501(SF1 lost) / AL502 (SF2 lost) (signal loss or signal error)

When either SF1 signal or SF2 signal becomes OFF, the STO function is activated, the circuit cuts off the current to the motor within 10 ms, and the servo drive is Off, triggering AL500. After 1 second, AL501 or AL502 is triggered. The following diagram illustrates how AL501 is triggered.

The panel displays either “AL500” or “-STO-” according to the setting of P1.120.

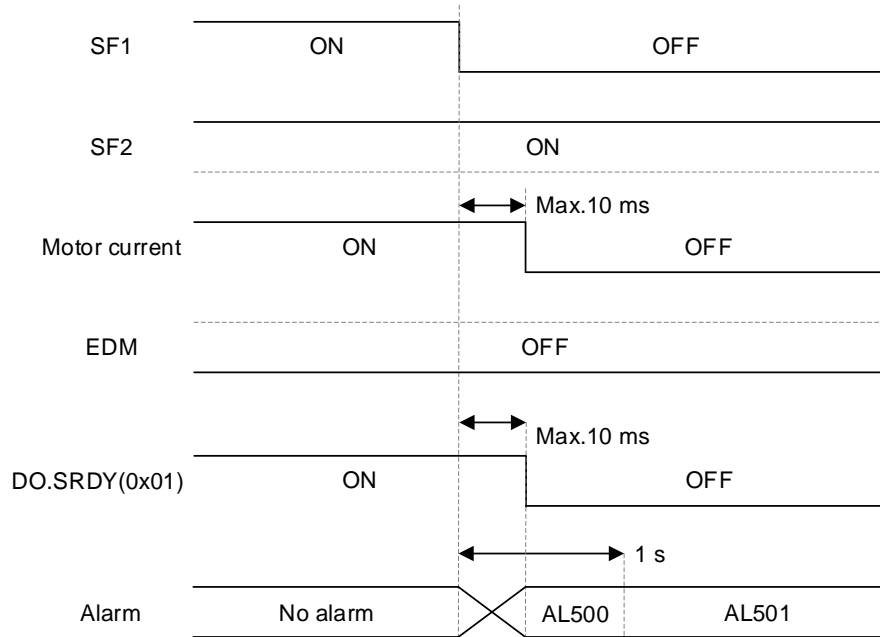

Note: when SF1 becomes OFF, AL501 occurs. When SF2 becomes OFF, AL502 occurs.

### 3.10.5.3 STO deactivation settings

Set P1.120 to choose the way to deactivate the STO function.

P1.120	Function
0	Switching on the servo drive is invalid / prohibited when the STO function is activated. To deactivate the STO function and restart the servo drive, send the Servo Off command to cancel the state (Servo On invalid / prohibited), and then send the Servo On command. DMCNET communication does not support this setting.
1	AL500 is triggered after the STO function is activated. To deactivate the STO function and restart the servo drive, you have to clear the alarm first, and then send the Servo Off command to cancel the state (Servo On invalid / prohibited) and send the Servo On command. DMCNET communication does not support this setting.
2	Switching on the servo drive is invalid / prohibited when the STO function is activated. The servo drive starts to operate again after the STO function is deactivated. DMCNET communication does not support this setting.
3 (Default)	AL500 is triggered after the STO function is activated. To deactivate the STO function and restart the servo drive, you have to clear the alarm.

(1) When P1.120 = 0 and the Servo On / Off command is sent with external DI

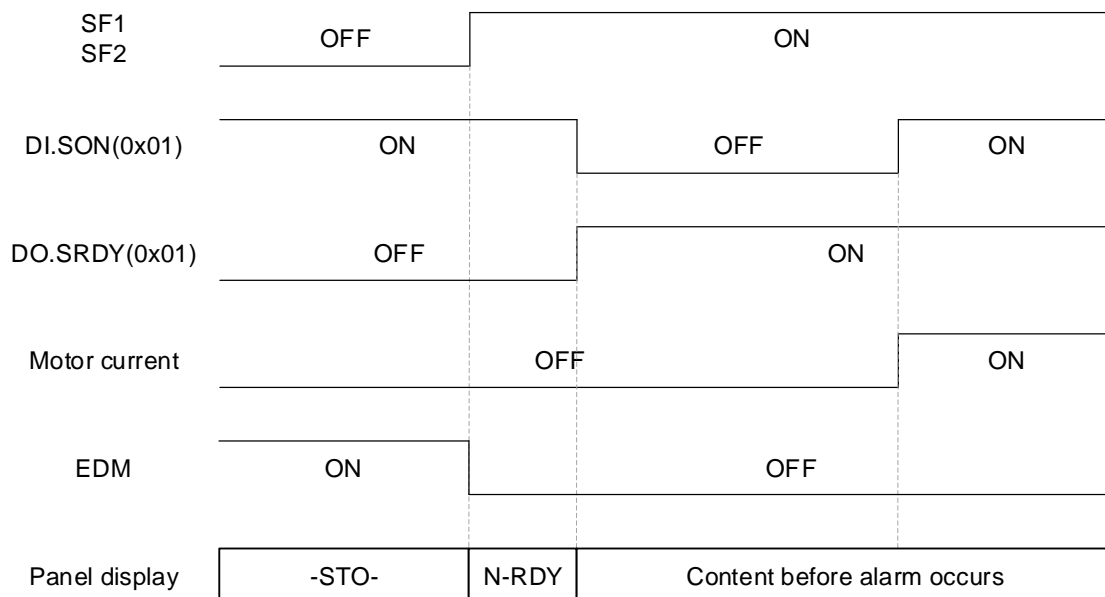

Note: DI.SON is invalid in communication modes, and thus you have to switch the drive to Servo On with the controller.

3

(2) When P1.120 = 0 and the Servo On / Off command is sent through EtherCAT / CANopen communication

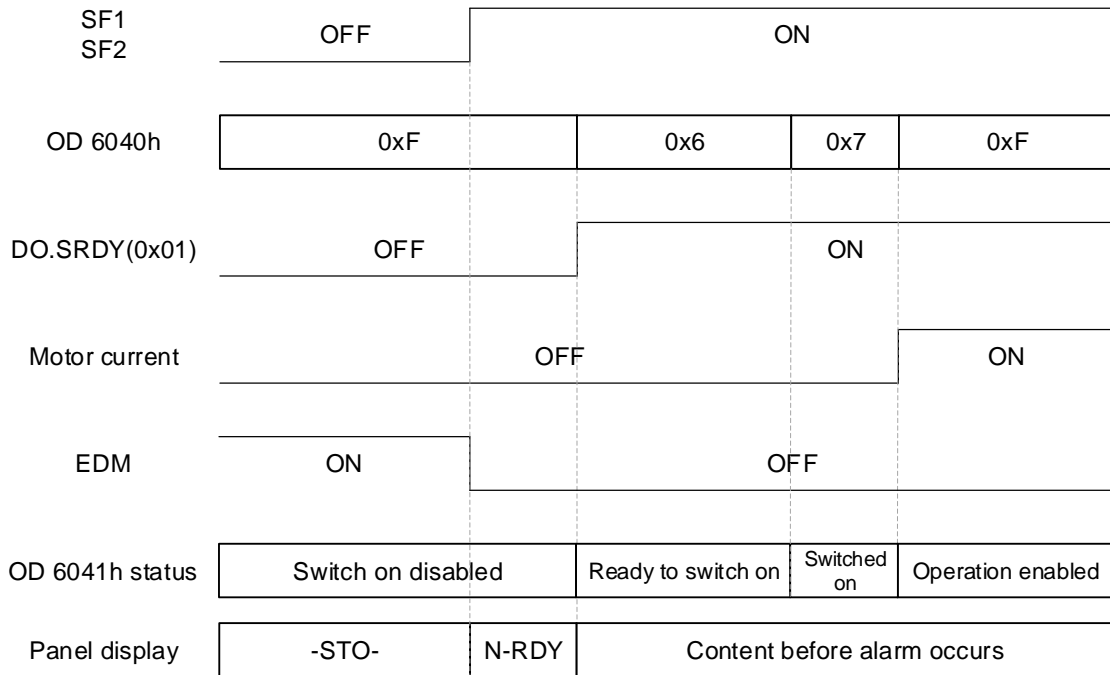

(3) When P1.120 = 1 and the Servo On / Off command is sent with external DI

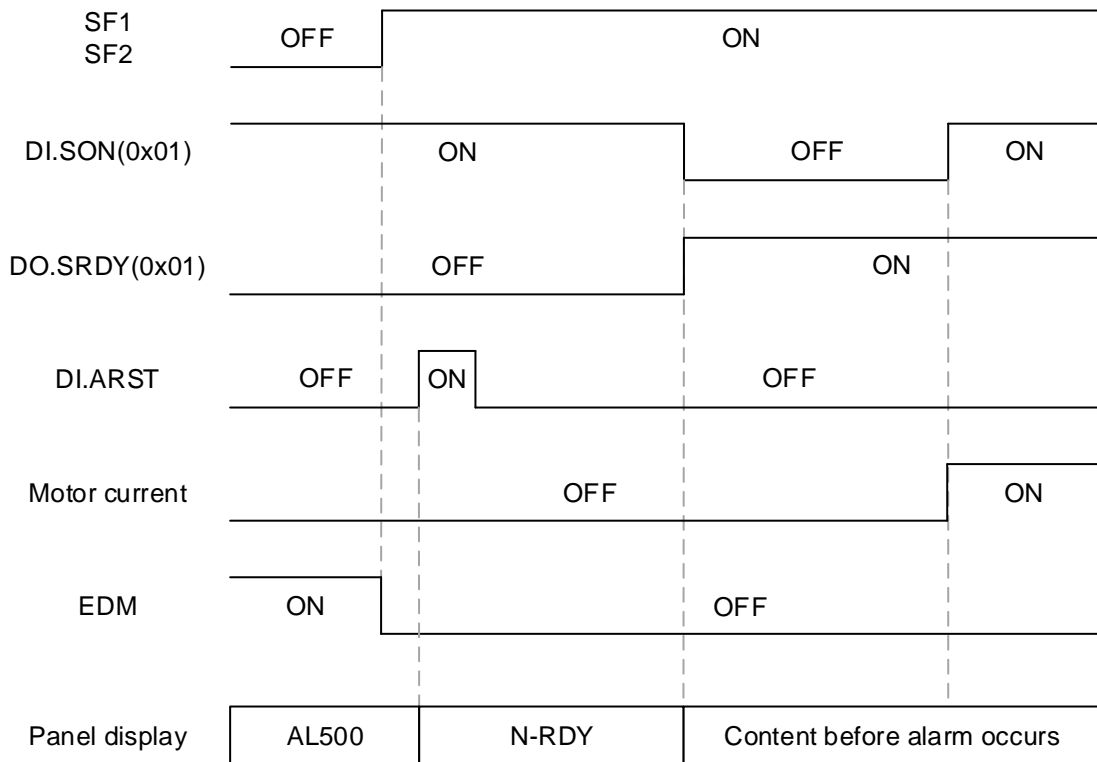

- (4) When P1.120 = 1 and the Servo On / Off command is sent through EtherCAT / CANopen communication

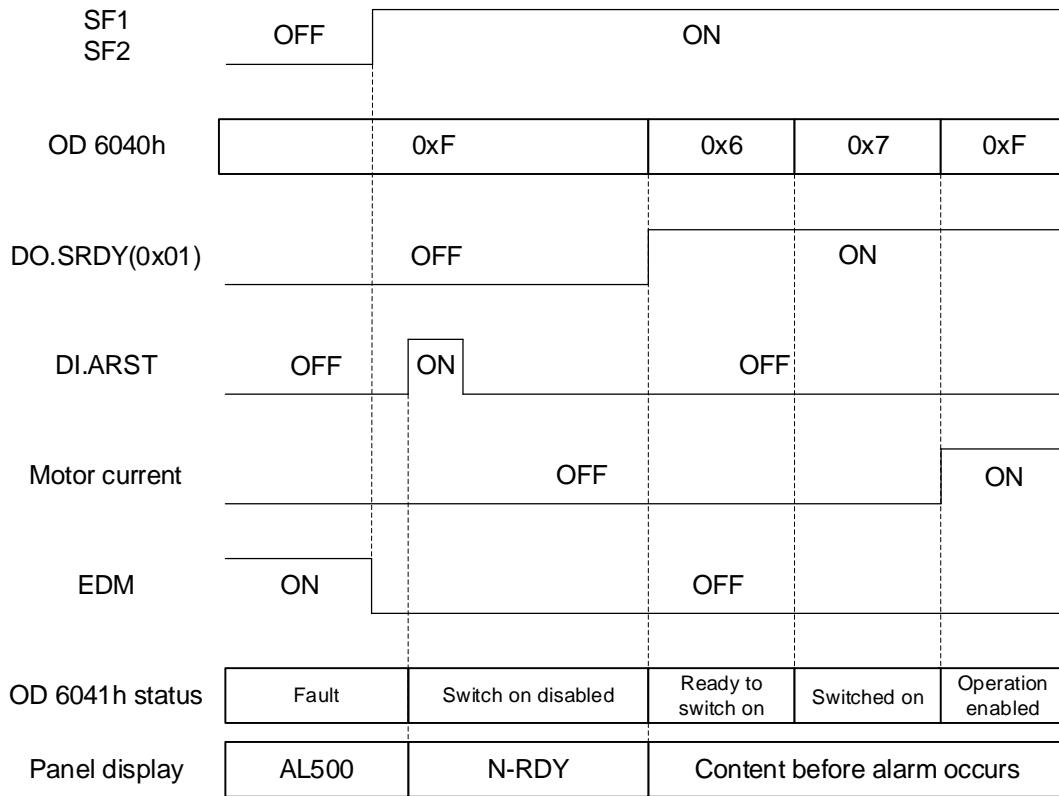

- (5) When P1.120 = 2 and the Servo On / Off command is sent with external DI

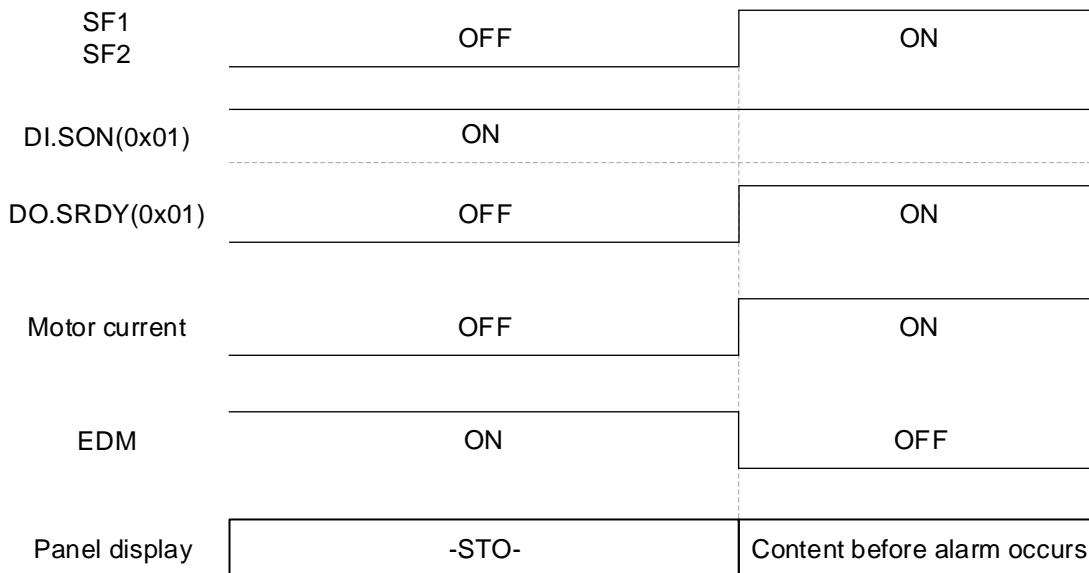

Note: if you switch the STO signals to ON when the servo drive sends the position or speed command to the motor, it may cause drastic motor rotation. Before switching the STO signals to ON, check if there is any command input and ensure personnel safety.

3

(6) When P1.120 = 2 and the Servo On / Off command is sent through EtherCAT / CANopen communication

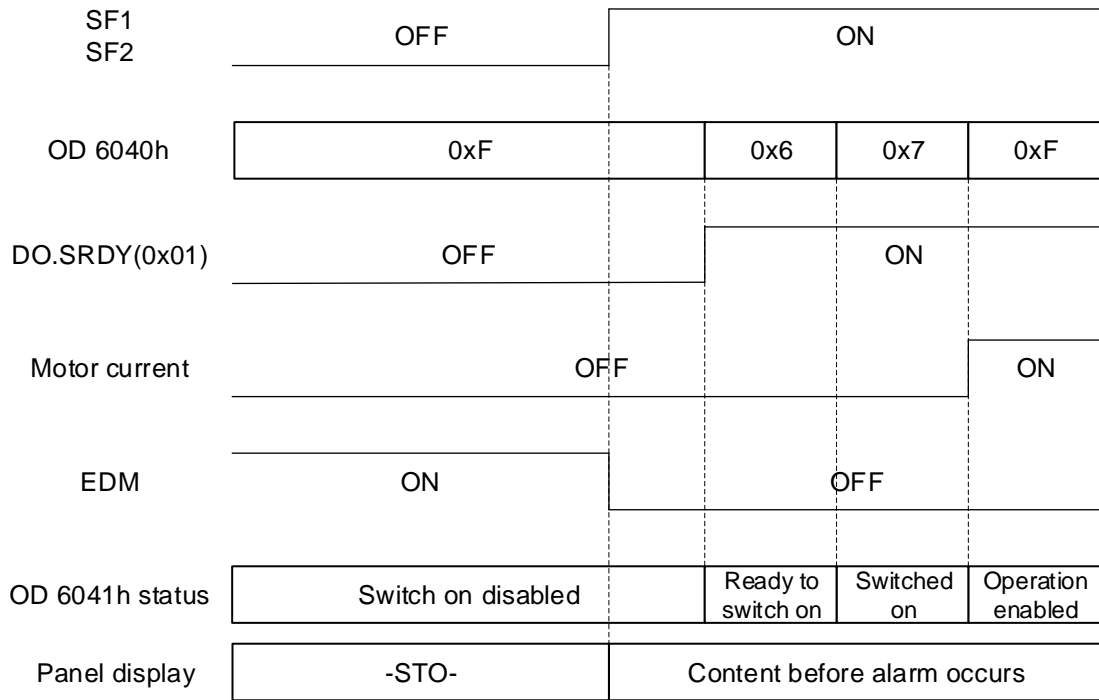

(7) When P1.120 = 3 and the Servo On / Off command is sent with external DI

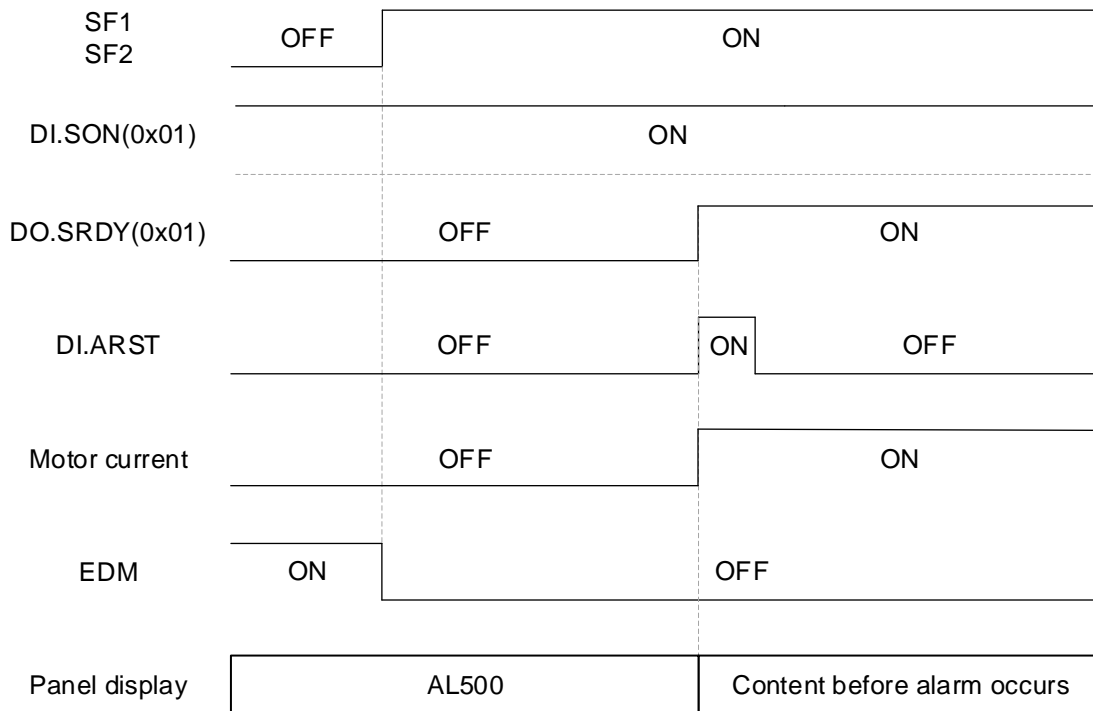

(8) When P1.120 = 3 and the Servo On / Off command is sent through EtherCAT / CANopen communication

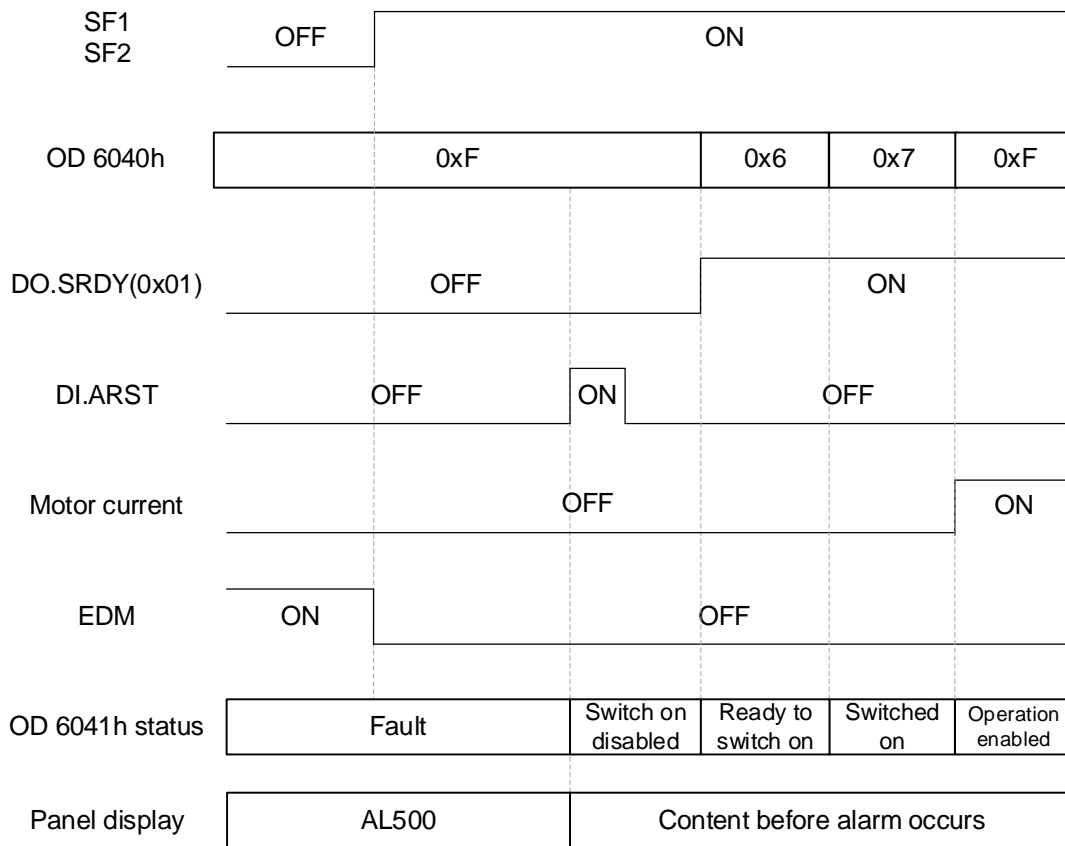

(9) When P1.120 = 3 and the Servo On / Off command is sent through DMCNET communication

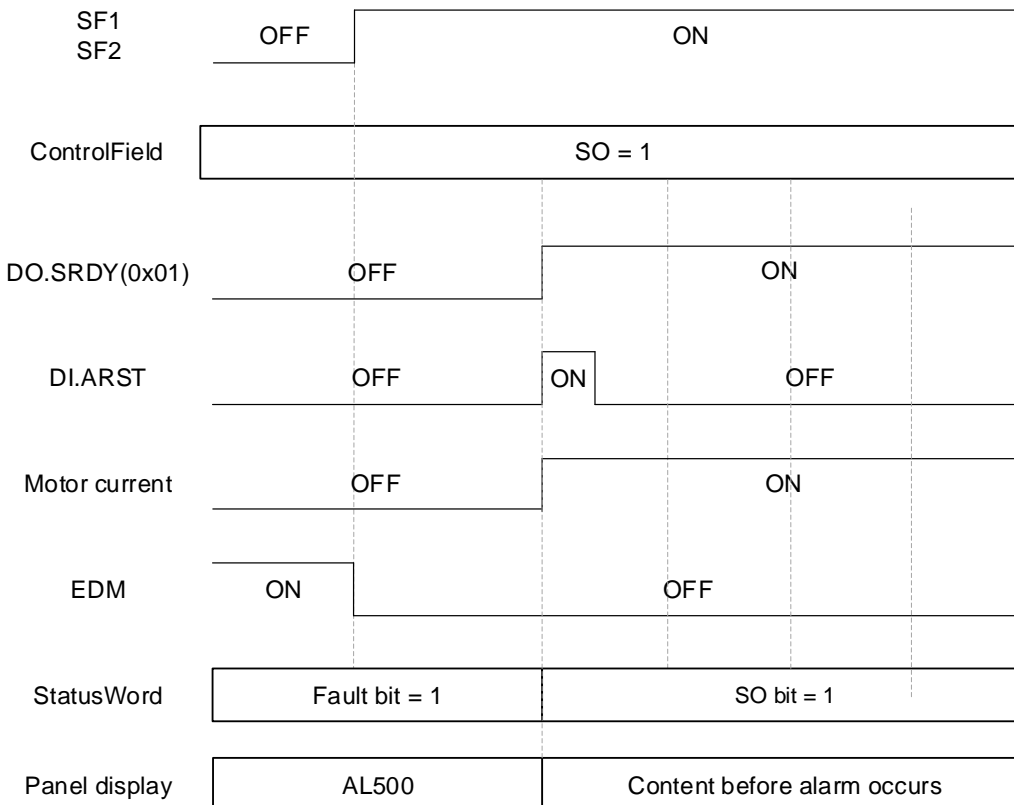



# 3

## 3.10.6 Wiring for STO

For STO wiring, the recommended wire gauge is 0.11 - 0.52 mm<sup>2</sup> (AWG 30 - 20).

### 3.10.6.1 CN10 STO connector

This connector provides the STO function.

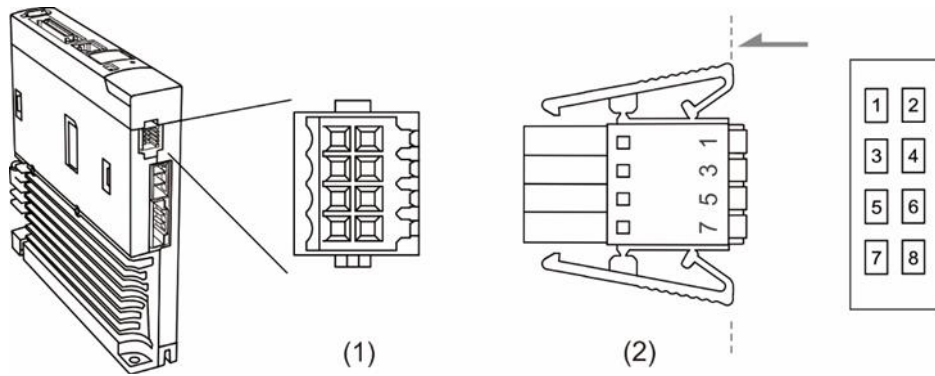

(1) CN10 STO connector (female); (2) CN10 STO connector (male)

Pin assignment:

Pin No.	Signal	Description	Function
1	-	Reserved	For deactivating the STO function; refer to Section 3.10.6.3 for the wiring diagram. Do not connect these two pins if using the STO function is required.
2	-	Reserved	
3	SF1+	STO input SF1+	Input signal for the STO function. ON (close): servo drive is in normal operation OFF (open): STO is activated
4	SF1-	STO input SF1-	
5	SF2+	STO input SF2+	Input signal for the STO function. ON (close): servo drive is in normal operation OFF (open): STO is activated
6	SF2-	STO input SF2-	
7	EDM+	Diagnostic output+	Monitoring outputs for STO input status and STO circuit failure.
8	EDM-	Diagnostic output-	

If you do not need the STO function, plug in the STO connector that comes with the servo drive. The short-circuit wiring has been done as shown in the figure on the right. If the wiring is removed, refer to the wiring information in Section 3.10.6.3 Not using the STO function.

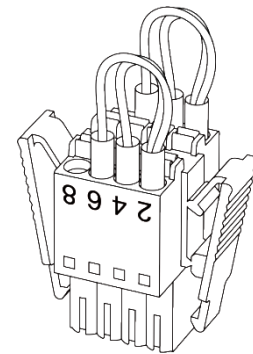

3.10.6.2 Input / output signal specification

(1) Safety input signals (SF1+, SF1-, SF2+, SF2-)

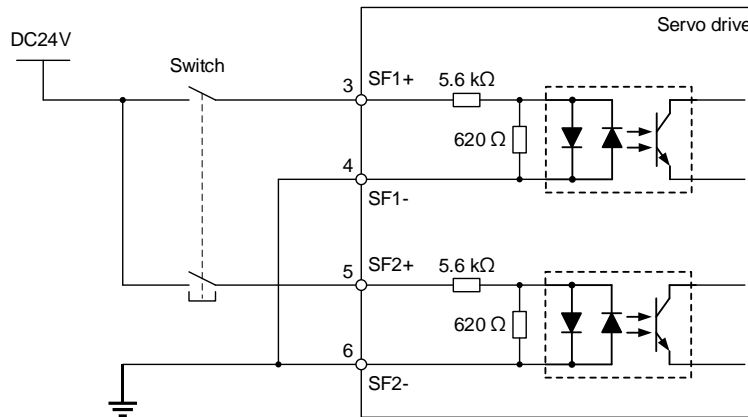

Item	Specification	Note
Internal impedance	5.6 kΩ	-
Operable voltage	DC24V ± 20%	Use the SELV power source.
Maximum delay time	10 ms	The time duration from STO signal Off to STO function activated.

- The Off time duration of the external test pulse input should be less than 1 ms.

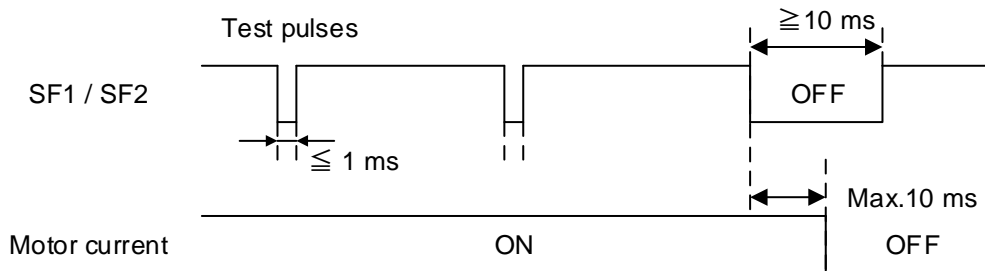

(2) Diagnostic output signal (EDM+, EDM-)

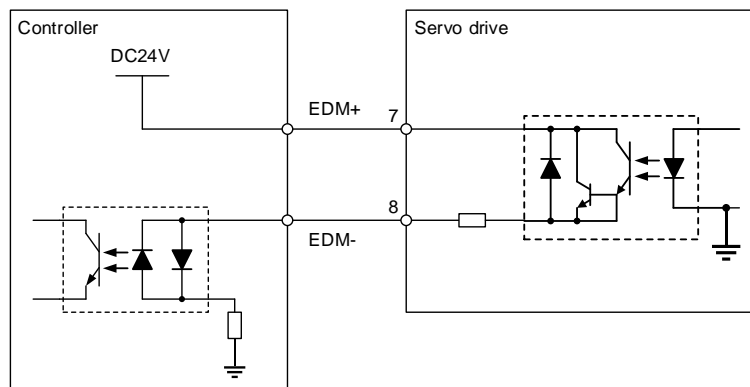

Item	Specification	Note
Maximum allowable voltage	DC24V	Use the SELV power source.
Maximum allowable current	50 mA	-
Maximum voltage drop	1.5V	When the current is 50 mA.

3

### 3.10.6.3 Not using the STO function

Follow the diagram for wiring or plug in the short-circuit connector that comes with the servo drive.

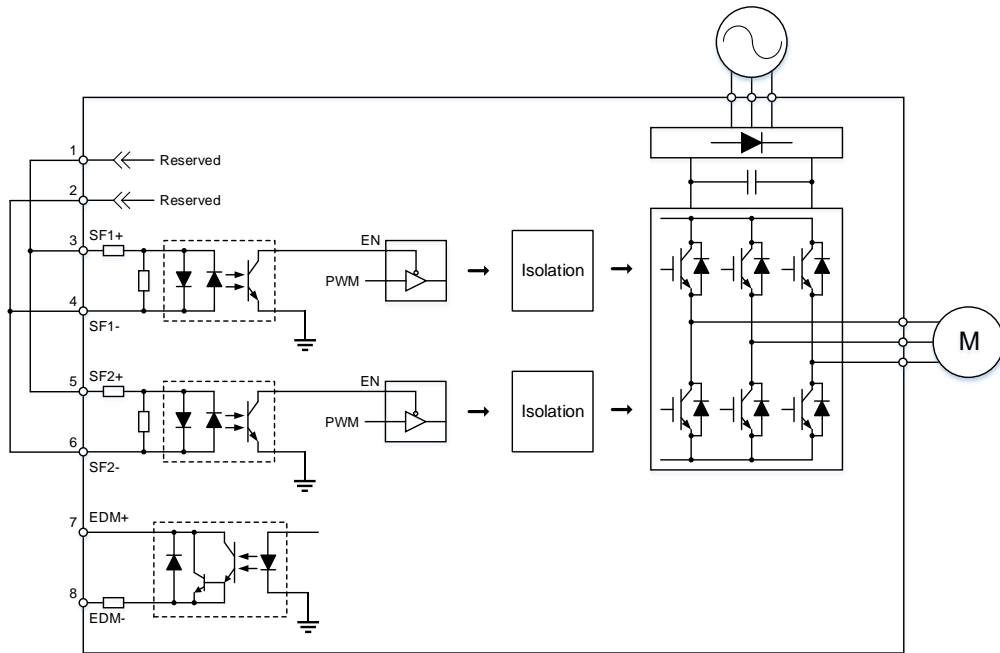

### 3.10.6.4 Using the STO function for a single drive

To use a safety relay to trigger the STO function, follow the diagram for wiring.

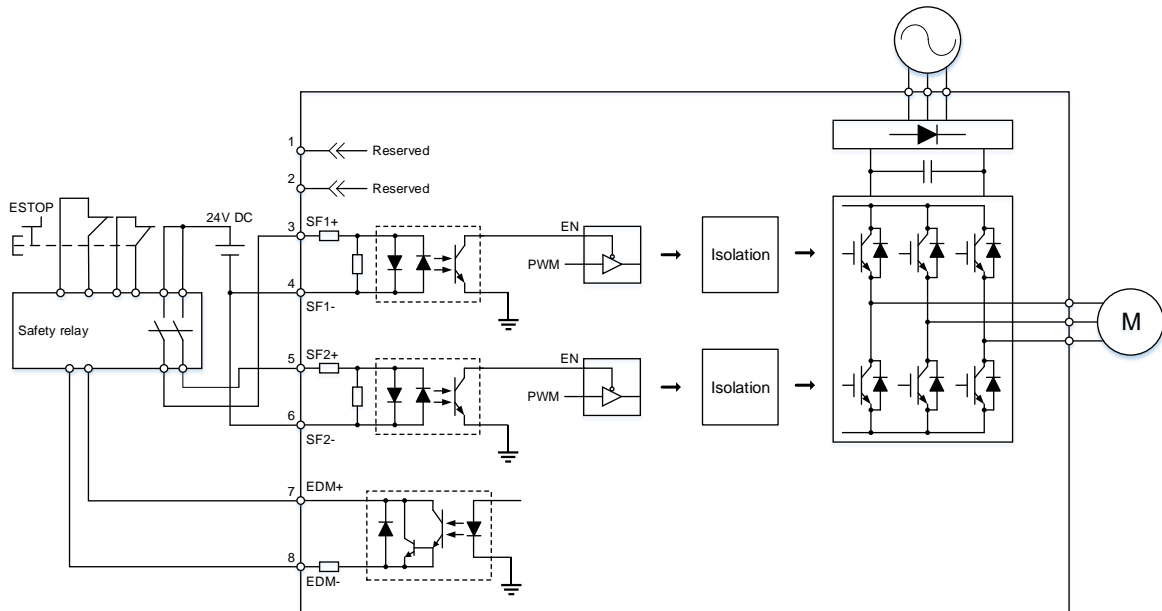

### 3.10.6.5 Using the STO function for multiple drives

Follow the diagram for wiring if using multiple servo drives. However, ensure the value of multiplying PFH and the number of servo drives is within the intended safety value for the multi-axis servo system.

3

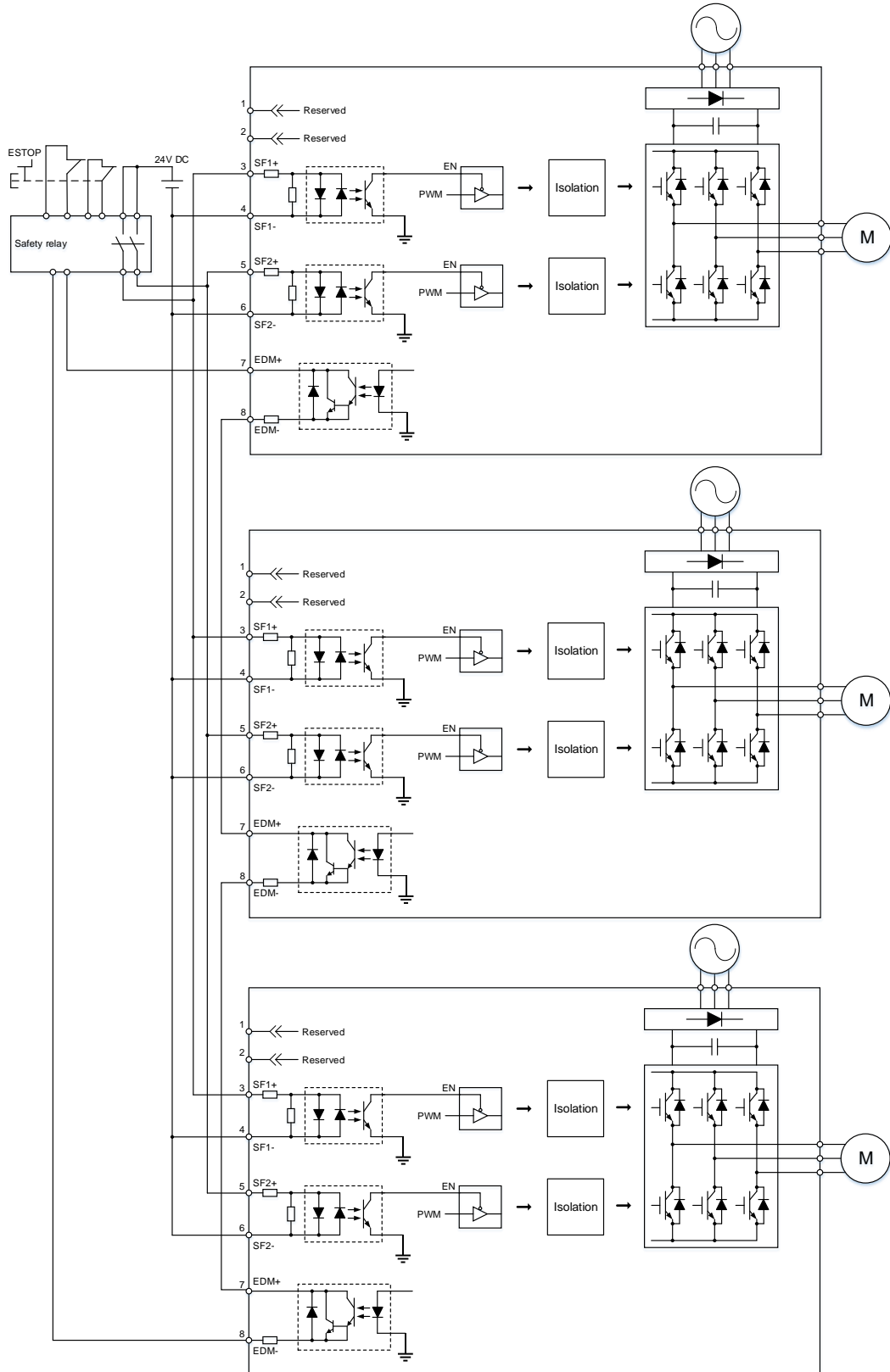

## 3

**3.10.7 Validation test**

When installing, maintaining, or changing the servo drive, ensure to perform the following validation tests. (It is suggested that you keep a record of the test results.)

■ **With EDM diagnosis (SIL3 system)**

- (1) When either SF1 or SF2 signal is off, the servo motor cannot be operated.
- (2) When you switch the SF1 and SF2 signals to ON or OFF, the input / output logic has to be in accordance with the following table.

Signal		Status of opto-isolator			
STO	SF1+ SF1-	ON	ON	OFF	OFF
	SF2+ SF2-	ON	OFF	ON	OFF
Diagnostic output (EDM)		OFF	OFF	OFF	ON

■ **Without EDM diagnosis (SIL2 system)**

- (1) When either SF1 or SF2 signal is off, the servo motor cannot be operated.
- (2) When SF1 and SF2 signals are both ON or OFF, neither AL501 nor AL502 is triggered.

Note:

1. Ensure to perform the validation tests once every 3 months even if you do not install, maintain, or change the servo drive.
2. If an error or danger is diagnosed, switch the safety input signals to OFF to have the servo drive enter the safe state.

### 3.11 220V series – Standard wiring example

#### 3.11.1 Position (PT) control mode – differential line driver signal input

3

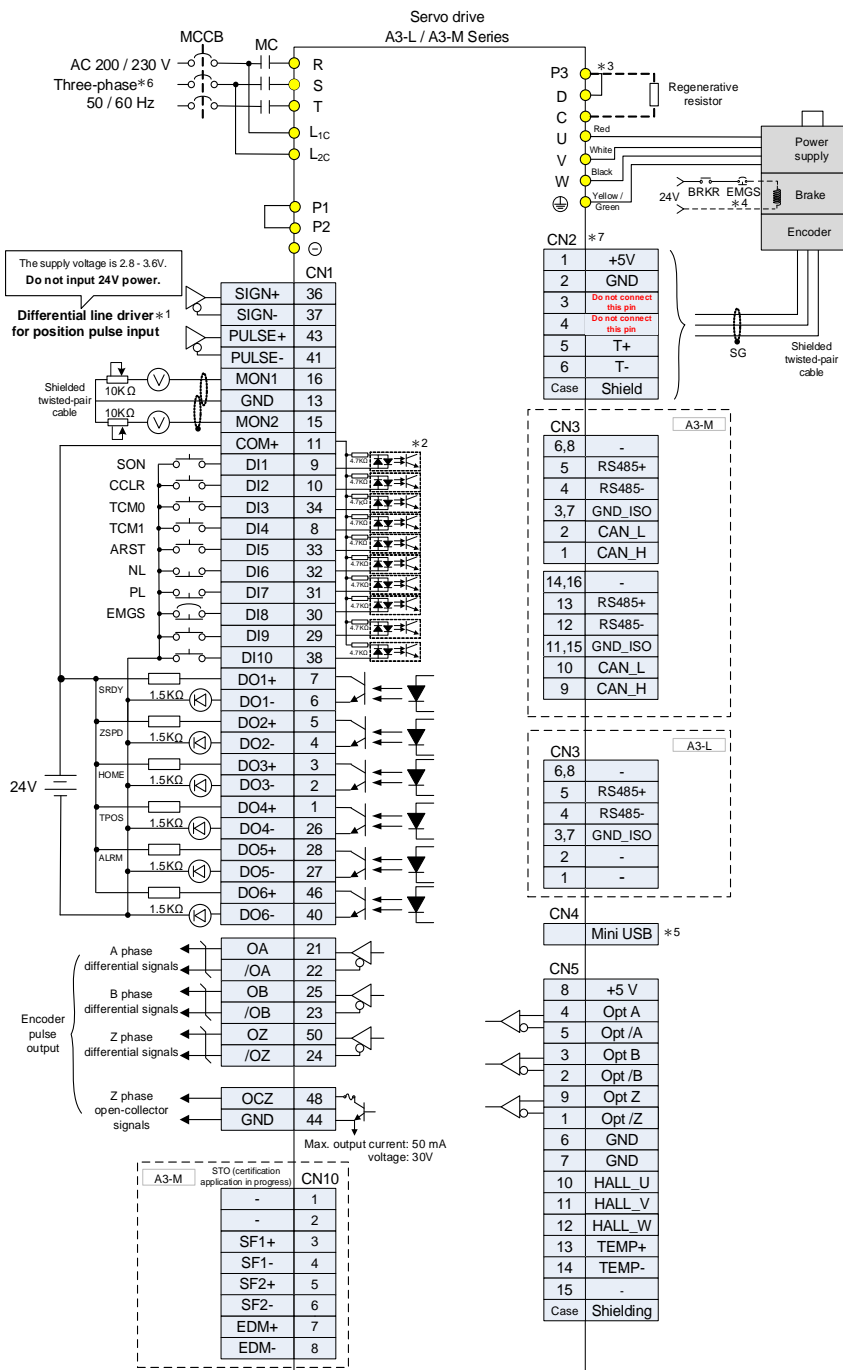

Note:

- \*1. The preceding figure uses the differential line driver for position pulse input. For open-collector signal input, refer to Section 3.11.2.
- \*2. Refer to Section 3.4.1.3 for wiring diagrams C7 SINK / C8 SOURCE.
- \*3. Only models of 400 W - 4.5 kW have built-in regenerative resistors.
- \*4. The brake coil has no polarity.
- \*5. Connects to the Mini-USB connector (for PC communication).
- \*6. Models of 1.5 kW and below can use single-phase power supply.
- \*7. The CN2 wiring in the figure is for a Delta communication type motor. Refer to Chapter 11 for the wiring instructions of third-party motors.

3

### 3.11.2 Position (PT) control mode – open-collector signal input

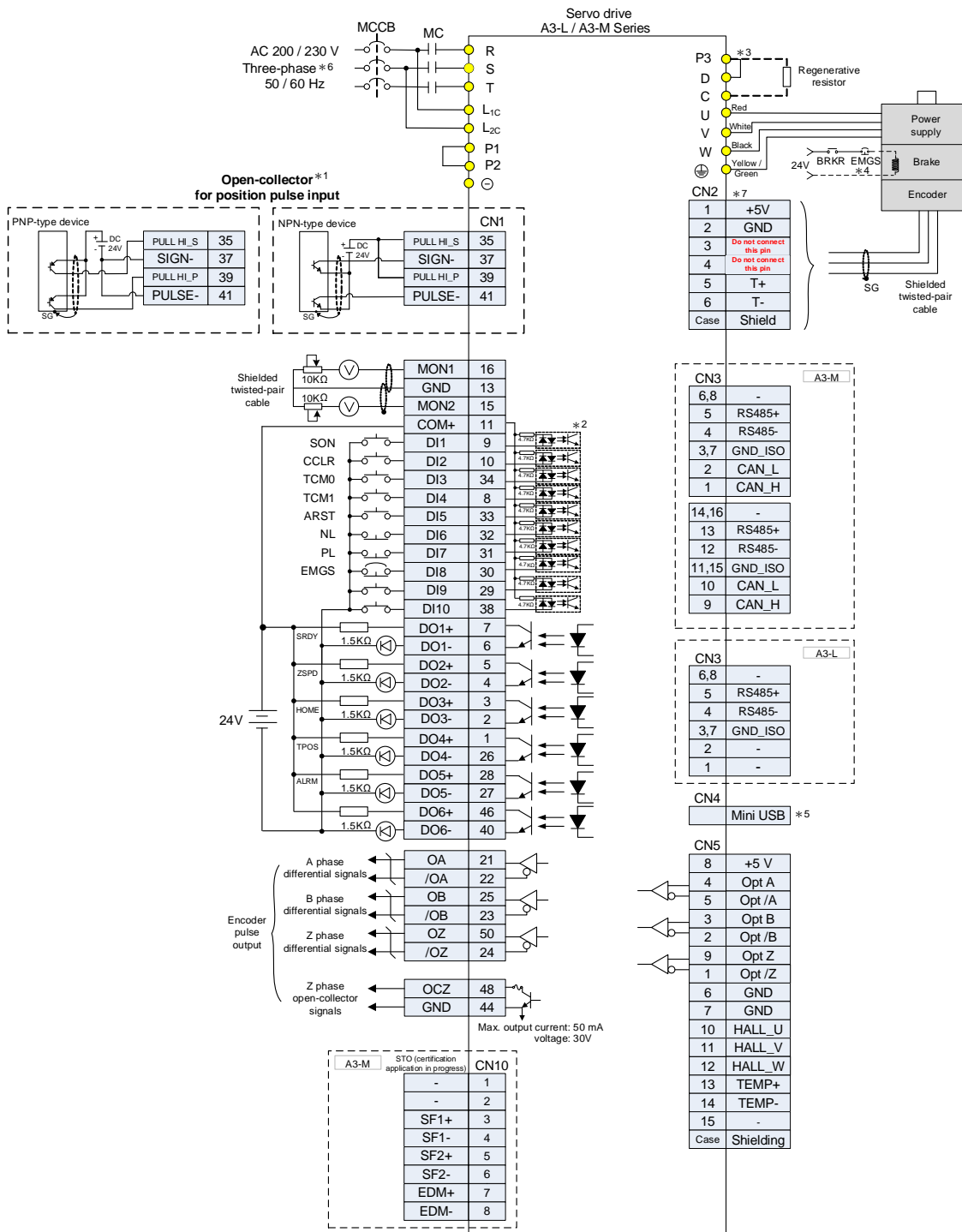

Note:

- \*1. The preceding figure uses the open-collector for position pulse input. For differential line driver signal input, refer to Section 3.11.1.
- \*2. Refer to Section 3.4.1.3 for wiring diagrams C7 SINK / C8 SOURCE.
- \*3. Only models of 400 W - 4.5 kW have built-in regenerative resistors.
- \*4. The brake coil has no polarity.
- \*5. Connects to the Mini-USB connector (for PC communication).
- \*6. Models of 1.5 kW and below can use single-phase power supply.
- \*7. The CN2 wiring in the figure is for a Delta communication type motor. Refer to Chapter 11 for the wiring instructions of third-party motors.

### 3.11.3 Position (PR) control mode – internal position commands

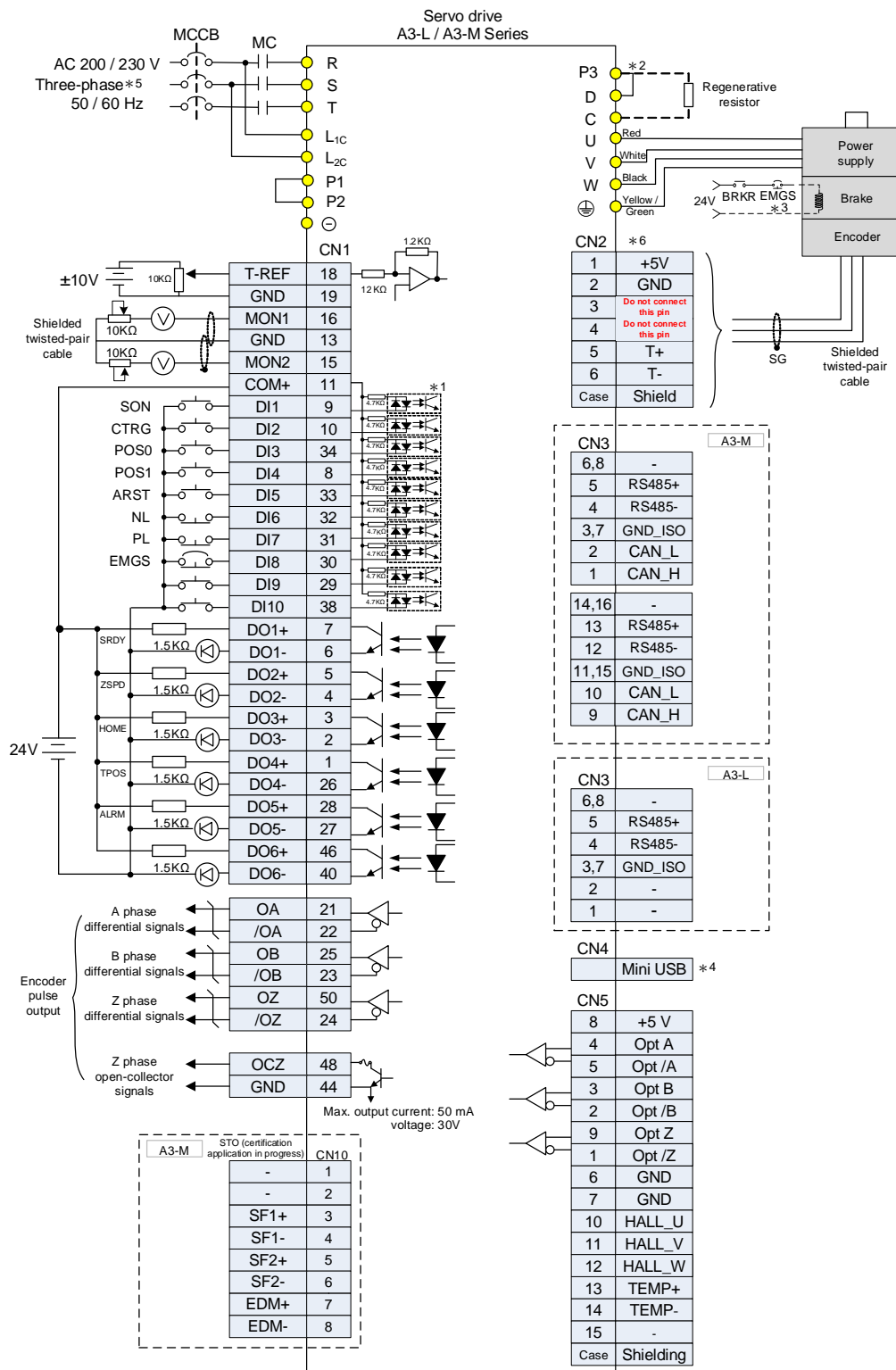

Note:

- \*1. Refer to Section 3.4.1.3 for wiring diagrams C7 SINK / C8 SOURCE.
- \*2. Only models of 400 W - 4.5 kW have built-in regenerative resistors.
- \*3. The brake coil has no polarity.
- \*4. Connects to the Mini-USB connector (for PC communication).
- \*5. Models of 1.5 kW and below can use single-phase power supply.
- \*6. The CN2 wiring in the figure is for a Delta communication type motor. Refer to Chapter 11 for the wiring instructions of third-party motors.

3



3

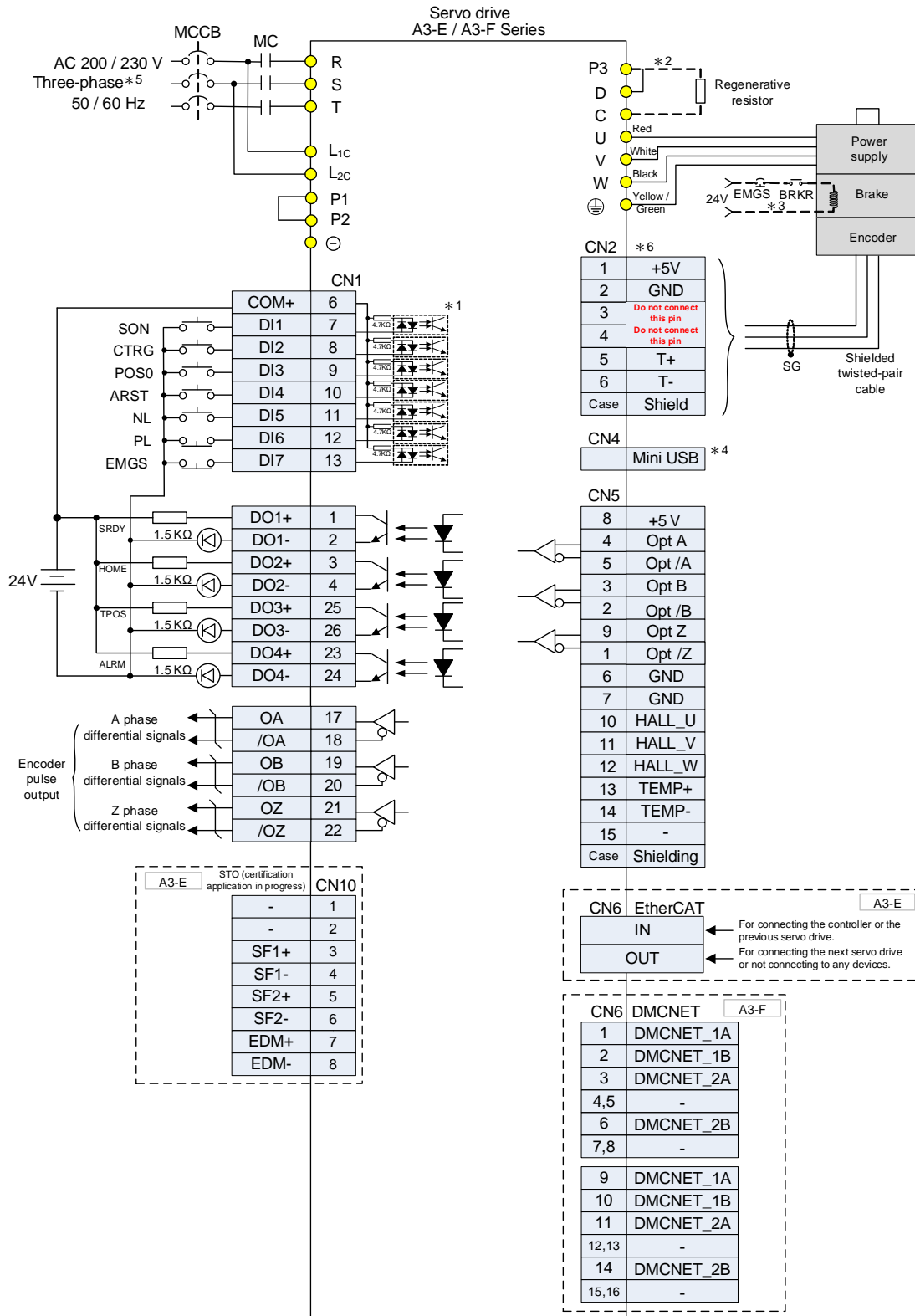

Note:

- \*1. Refer to Section 3.4.2.3 for wiring diagrams C7 SINK / C8 SOURCE.
- \*2. Only models of 400 W - 4.5 kW have built-in regenerative resistors.
- \*3. The brake coil has no polarity.
- \*4. Connects to the Mini-USB connector (for PC communication).
- \*5. Models of 1.5 kW and below can use single-phase power supply.
- \*6. The CN2 wiring in the figure is for a Delta communication type motor. Refer to Chapter 11 for the wiring instructions of third-party motors.

### 3.11.4 Speed (S) control mode

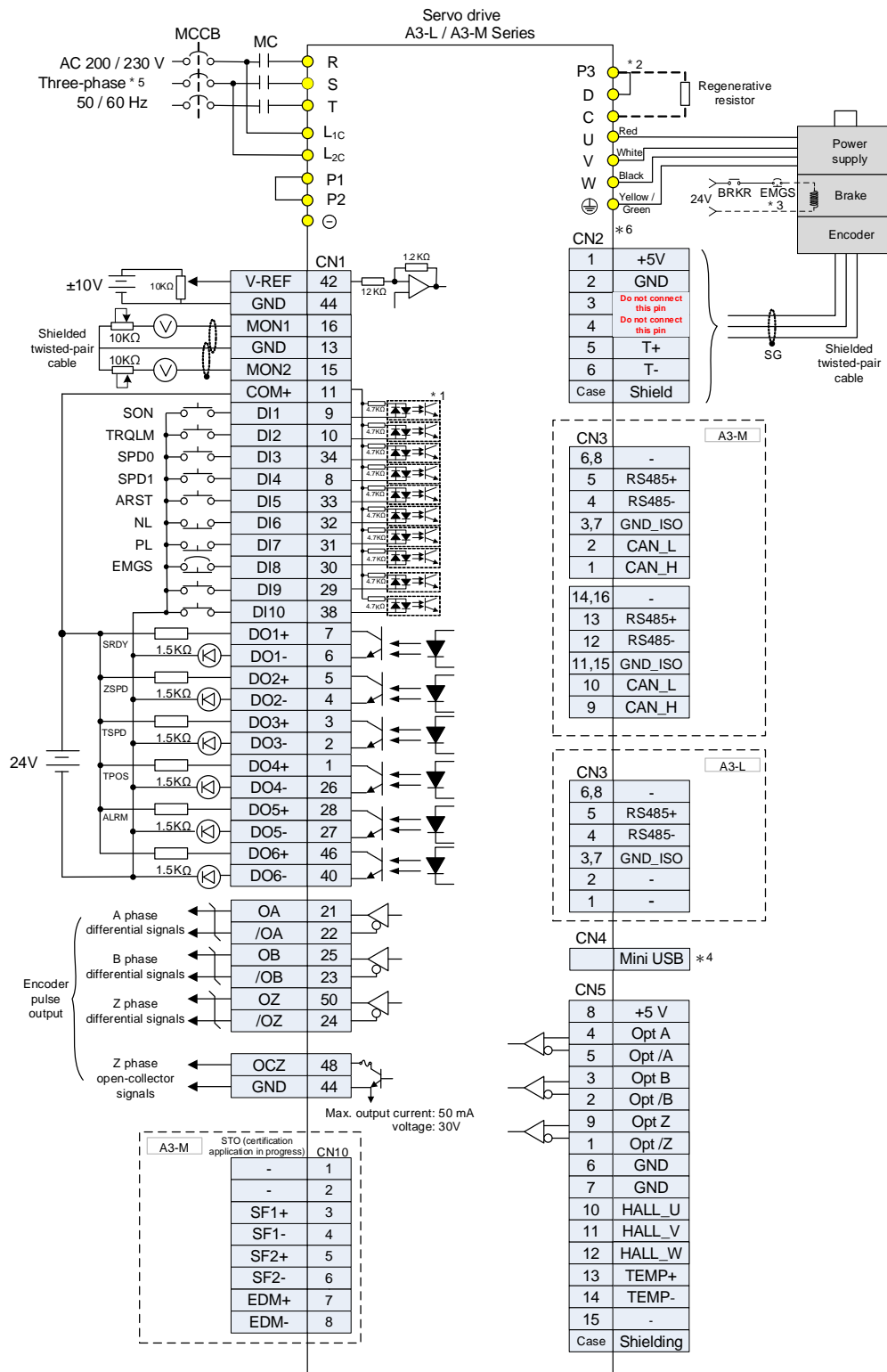

Note:

- \*1. Refer to Section 3.4.1.3 for wiring diagrams C7 SINK / C8 SOURCE.
- \*2. Only models of 400 W - 4.5 kW have built-in regenerative resistors.
- \*3. The brake coil has no polarity.
- \*4. Connects to the Mini-USB connector (for PC communication).
- \*5. Models of 1.5 kW and below can use single-phase power supply.
- \*6. The CN2 wiring in the figure is for a Delta communication type motor. Refer to Chapter 11 for the wiring instructions of third-party motors.

3

3

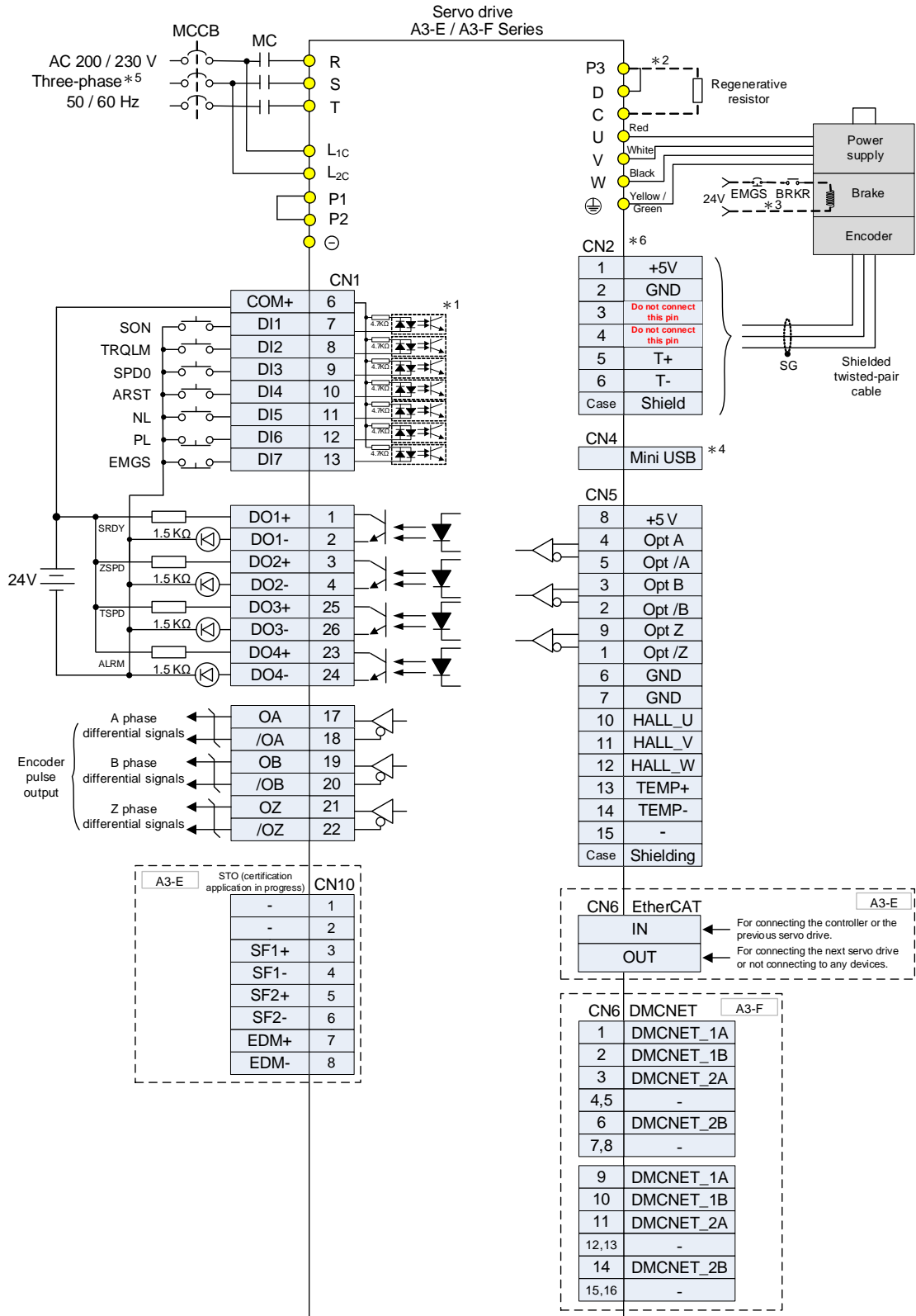

Note:

- \*1. Refer to Section 3.4.2.3 for wiring diagrams C7 SINK / C8 SOURCE.
- \*2. Only models of 400 W - 4.5 kW have built-in regenerative resistors.
- \*3. The brake coil has no polarity.
- \*4. Connects to the Mini-USB connector (for PC communication).
- \*5. Models of 1.5 kW and below can use single-phase power supply.
- \*6. The CN2 wiring in the figure is for a Delta communication type motor. Refer to Chapter 11 for the wiring instructions of third-party motors.

### 3.11.5 Torque (T) control mode

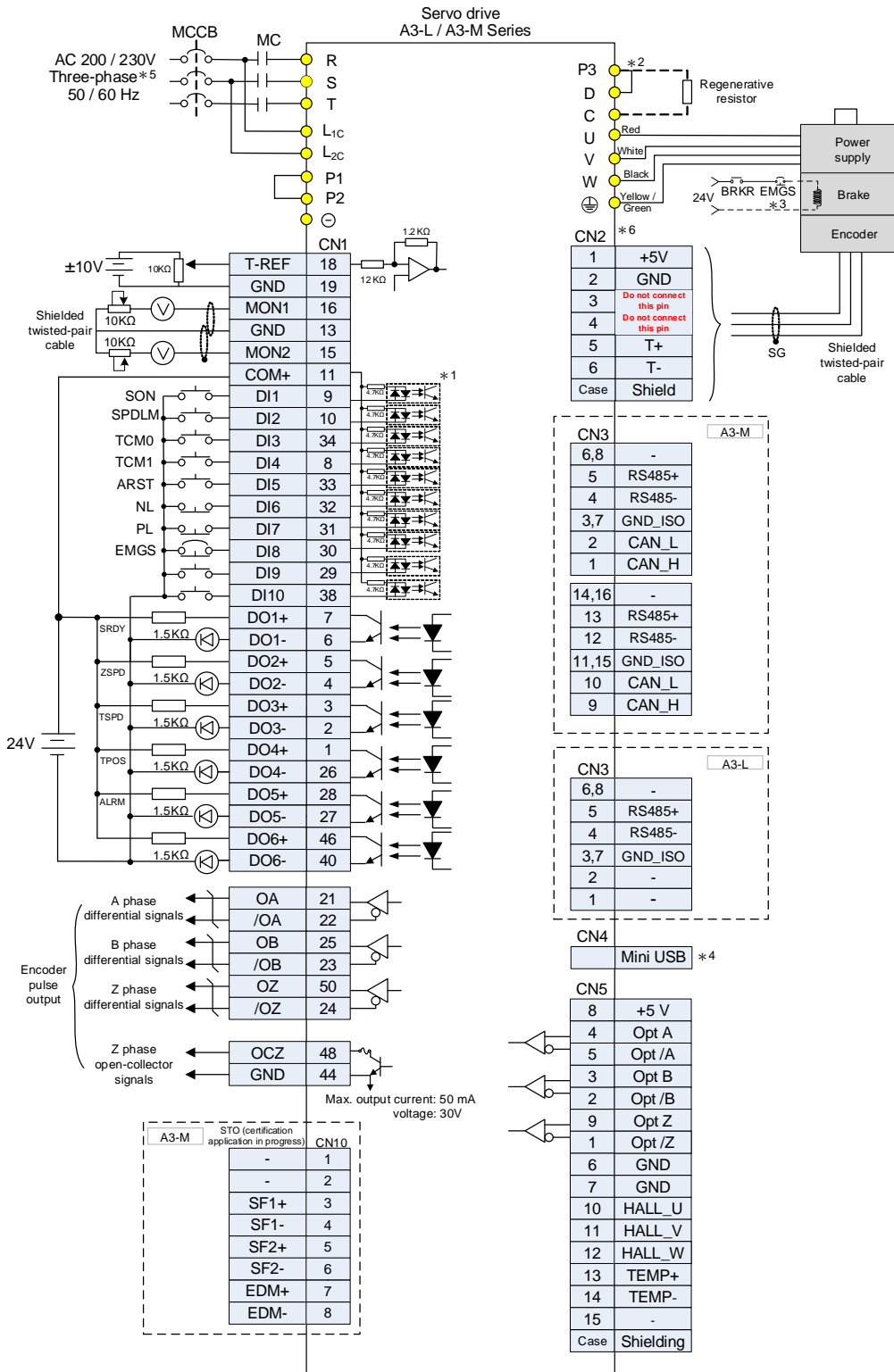

Note:

- \*1. Refer to Section 3.4.1.3 for wiring diagrams C7 SINK / C8 SOURCE.
- \*2. Only models of 400 W - 4.5 kW have built-in regenerative resistors.
- \*3. The brake coil has no polarity.
- \*4. Connects to the Mini-USB connector (for PC communication).
- \*5. Models of 1.5 kW and below can use single-phase power supply.
- \*6. The CN2 wiring in the figure is for a Delta communication type motor. Refer to Chapter 11 for the wiring instructions of third-party motors.

3

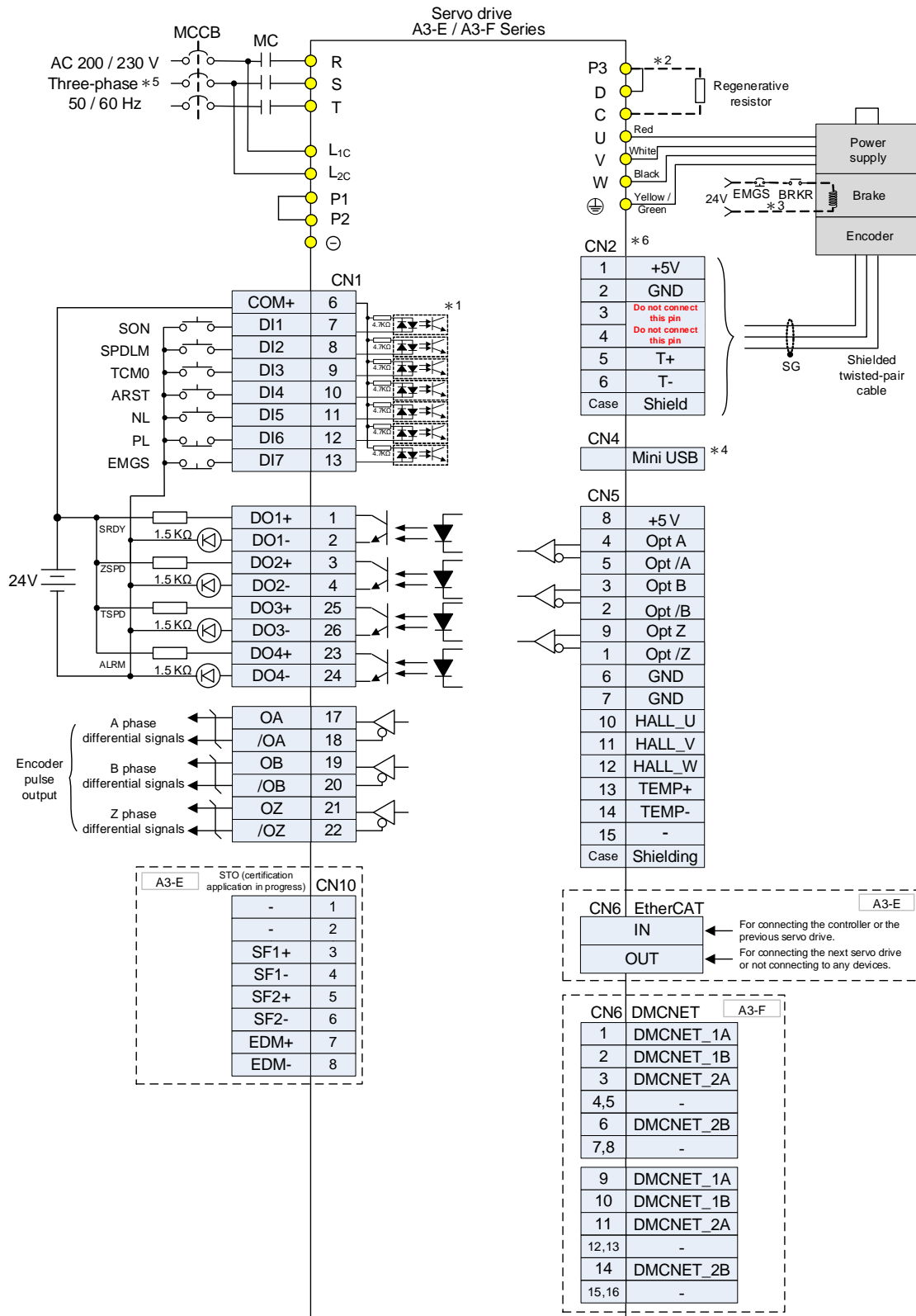

**Note:**

- \*1. Refer to Section 3.4.2.3 for wiring diagrams C7 SINK / C8 SOURCE.
- \*2. Only models of 400 W - 4.5 kW have built-in regenerative resistors.
- \*3. The brake coil has no polarity.
- \*4. Connects to the Mini-USB connector (for PC communication).
- \*5. Models of 1.5 kW and below can use single-phase power supply.
- \*6. The CN2 wiring in the figure is for a Delta communication type motor. Refer to Chapter 11 for the wiring instructions of third-party motors.

### 3.11.6 Communication mode (CANopen)

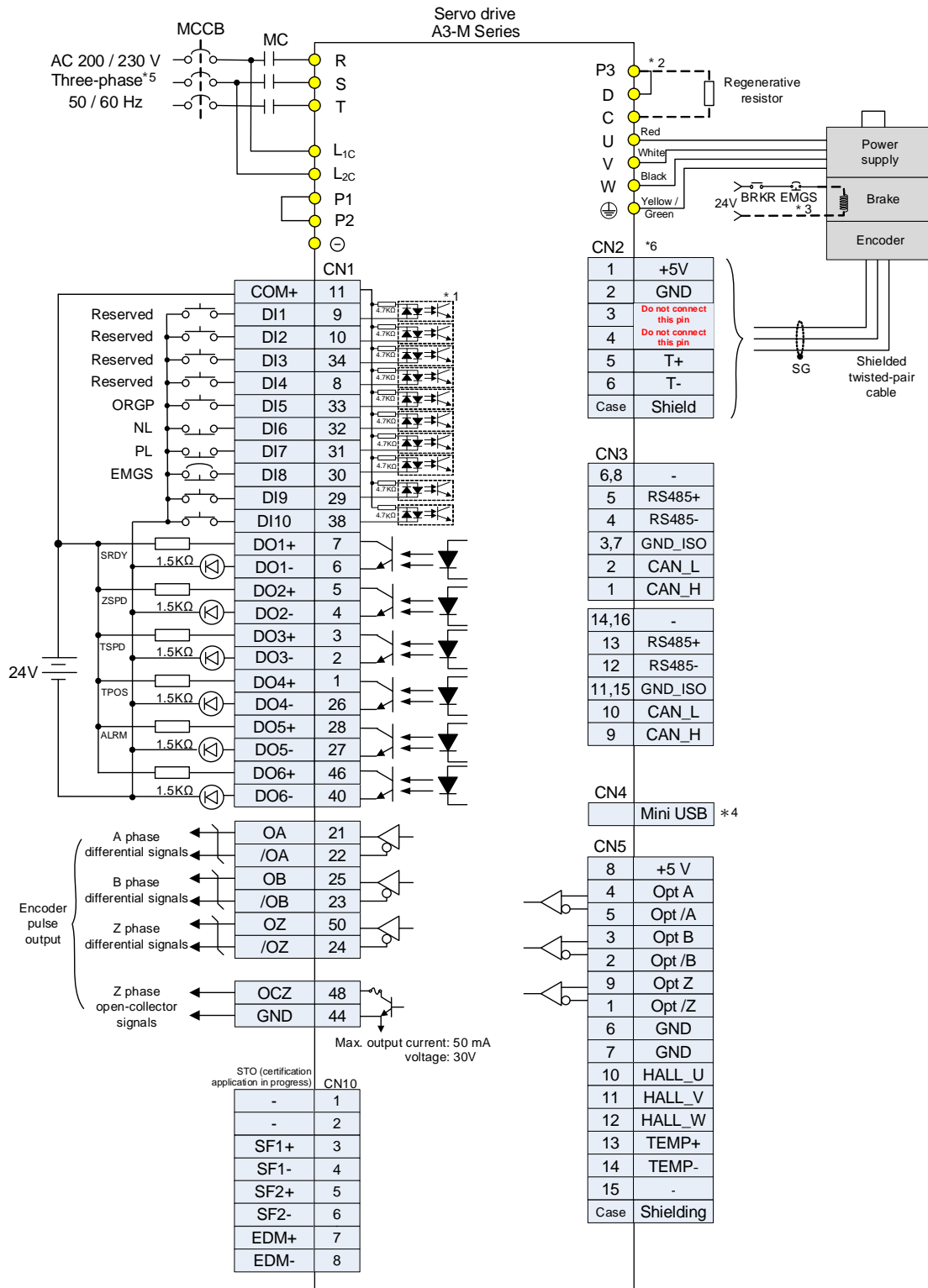

Note:

- \*1. Refer to Section 3.4.1.3 for wiring diagrams C7 SINK / C8 SOURCE.
- \*2. Only models of 400 W - 4.5 kW have built-in regenerative resistors.
- \*3. The brake coil has no polarity.
- \*4. Connects to the Mini-USB connector (for PC communication).
- \*5. Models of 1.5 kW and below can use single-phase power supply.
- \*6. The CN2 wiring in the figure is for a Delta communication type motor. Refer to Chapter 11 for the wiring instructions of third-party motors.

3

3

### 3.11.7 Communication mode (DMCNET)

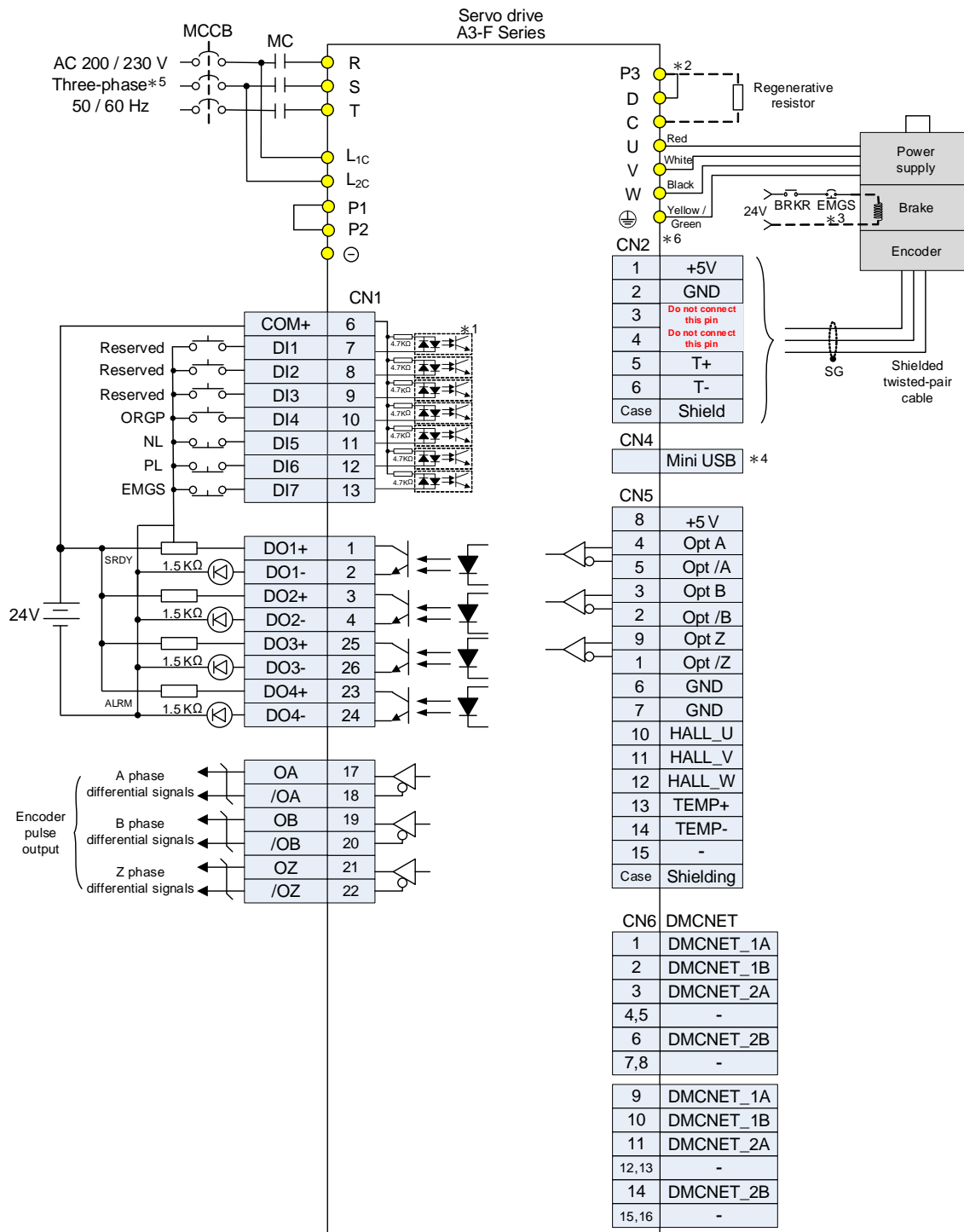

**Note:**

- \*1. Refer to section 3.4.2.3 for wiring diagrams C7 SINK / C8 SOURCE.
- \*2. Only models of 400 W - 4.5 kW have built-in regenerative resistors.
- \*3. The brake coil has no polarity.
- \*4. Connects to the Mini-USB connector (for PC communication).
- \*5. Models of 1.5 kW and below can use single-phase power supply.
- \*6. The CN2 wiring in the figure is for a Delta communication type motor. Refer to Chapter 11 for the wiring instructions of third-party motors.

### 3.11.8 Communication mode (EtherCAT)

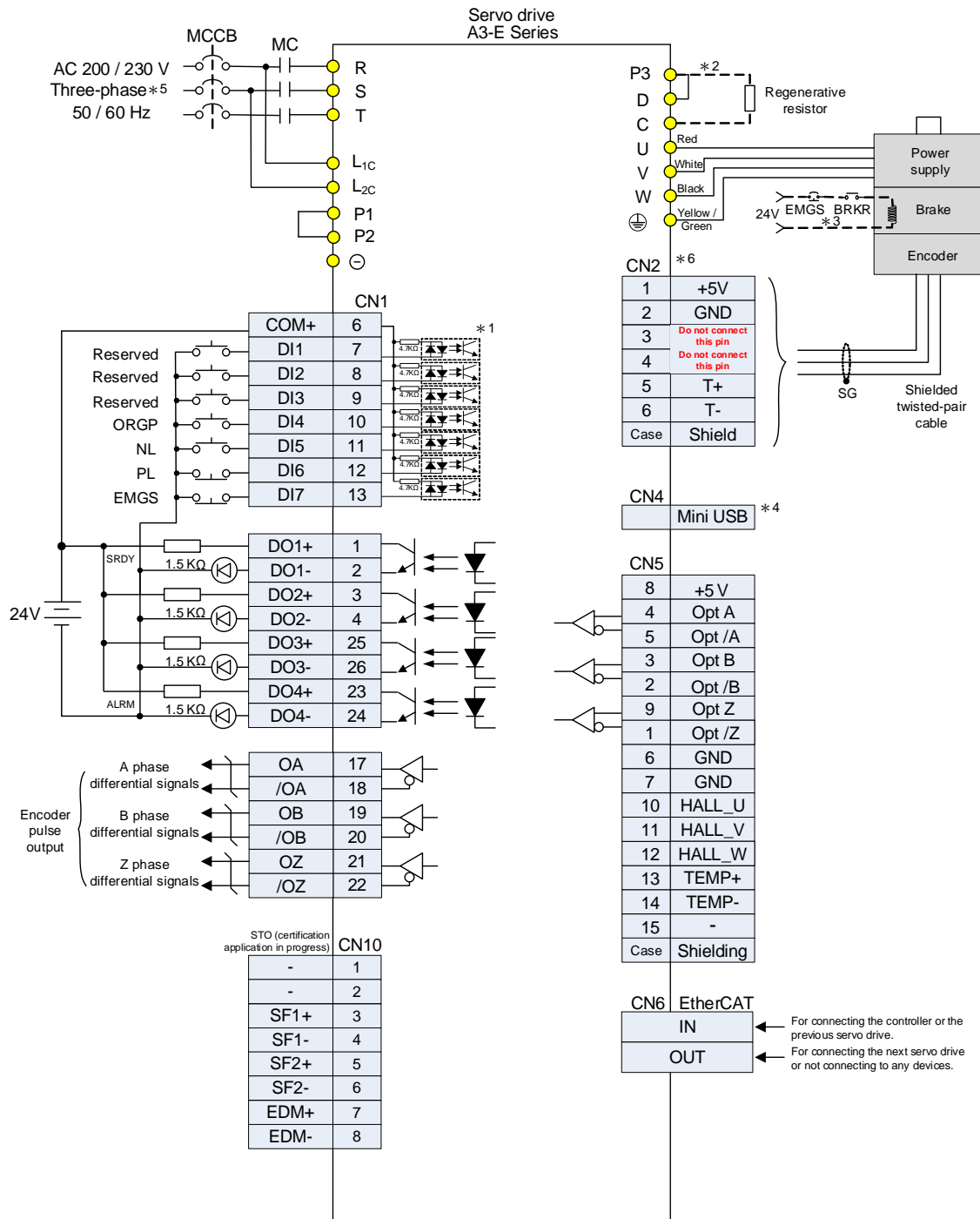

3

**Note:**

- \*1. Refer to section 3.4.2.3 for wiring diagrams C7 SINK / C8 SOURCE.
- \*2. Only models of 400 W - 4.5 kW have built-in regenerative resistors.
- \*3. The brake coil has no polarity.
- \*4. Connects to the Mini-USB connector (for PC communication).
- \*5. Models of 1.5 kW and below can use single-phase power supply.
- \*6. The CN2 wiring in the figure is for a Delta communication type motor. Refer to Chapter 11 for the wiring instructions of third-party motors.



### 3.12 400V series – Standard wiring example

#### 3.12.1 Position (PT) control mode – differential line driver signal input

3

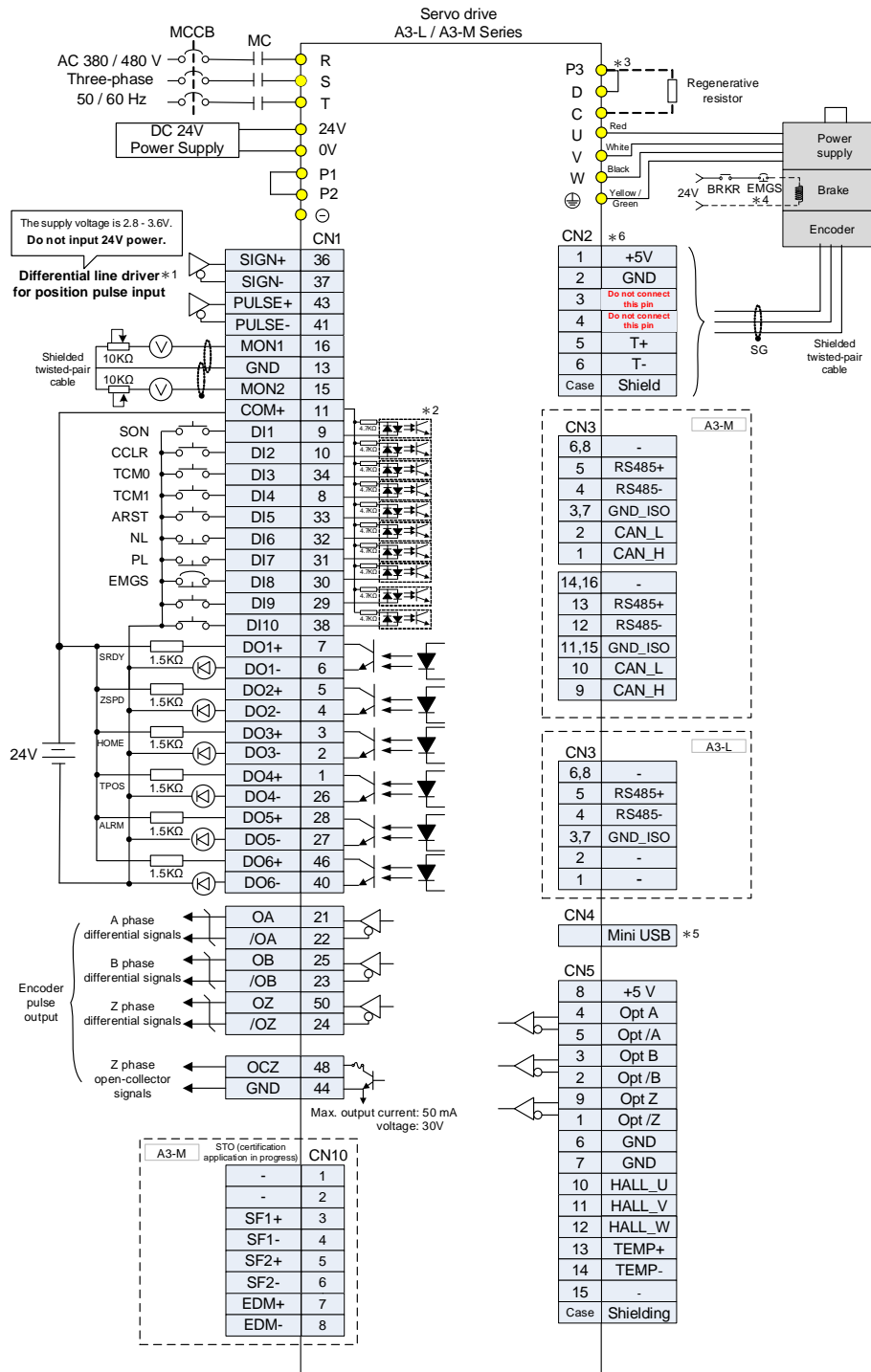

Note:

- \*1. The preceding figure uses the differential line driver for position pulse input. For open-collector signal input, refer to Section 3.12.2.
- \*2. Refer to Section 3.4.1.3 for wiring diagrams C7 SINK / C8 SOURCE.
- \*3. Only models of 1.5 kW and below have built-in regenerative resistors.
- \*4. The brake coil has no polarity.
- \*5. Connects to the Mini-USB connector (for PC communication).
- \*6. The CN2 wiring in the figure is for a Delta communication type motor. Refer to Chapter 11 for the wiring instructions of third-party motors.

### 3.12.2 Position (PT) control mode – open-collector signal input

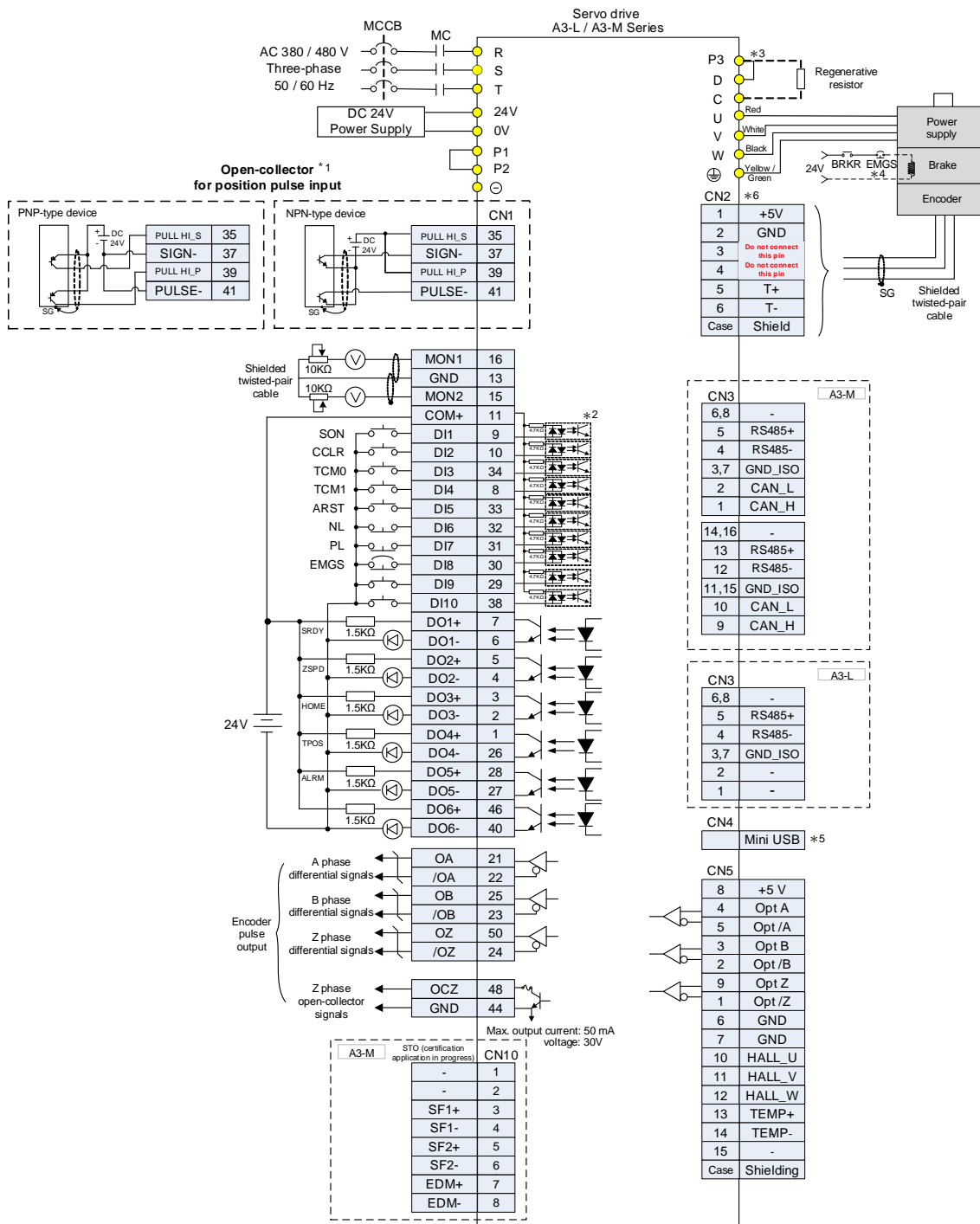

Note:

- \*1. The preceding figure uses the open-collector for position pulse input. For differential line driver signal input, refer to Section 3.12.1.
- \*2. Refer to Section 3.4.1.3 for wiring diagrams C7 SINK / C8 SOURCE.
- \*3. Only models of 1.5 kW and below have built-in regenerative resistors.
- \*4. The brake coil has no polarity.
- \*5. Connects to the Mini-USB connector (for PC communication).
- \*6. The CN2 wiring in the figure is for a Delta communication type motor. Refer to Chapter 11 for the wiring instructions of third-party motors.

### 3.12.3 Position (PR) control mode – internal position commands

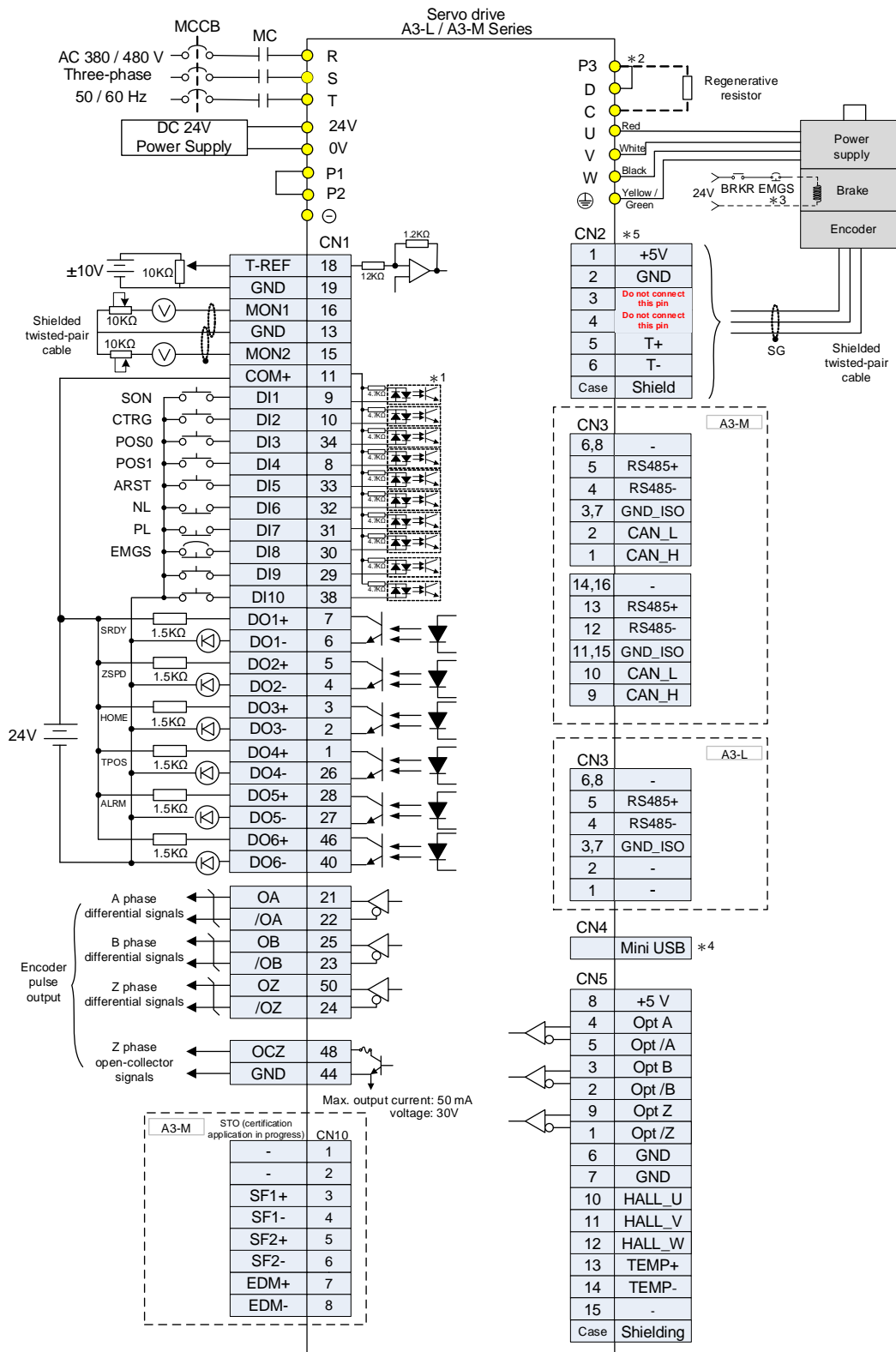

Note:

- \*1. Refer to Section 3.4.1.3 for wiring diagrams C7 SINK / C8 SOURCE.
- \*2. Only models of 1.5 kW and below have built-in regenerative resistors.
- \*3. The brake coil has no polarity.
- \*4. Connects to the Mini-USB connector (for PC communication).
- \*5. The CN2 wiring in the figure is for a Delta communication type motor. Refer to Chapter 11 for the wiring instructions of third-party motors.

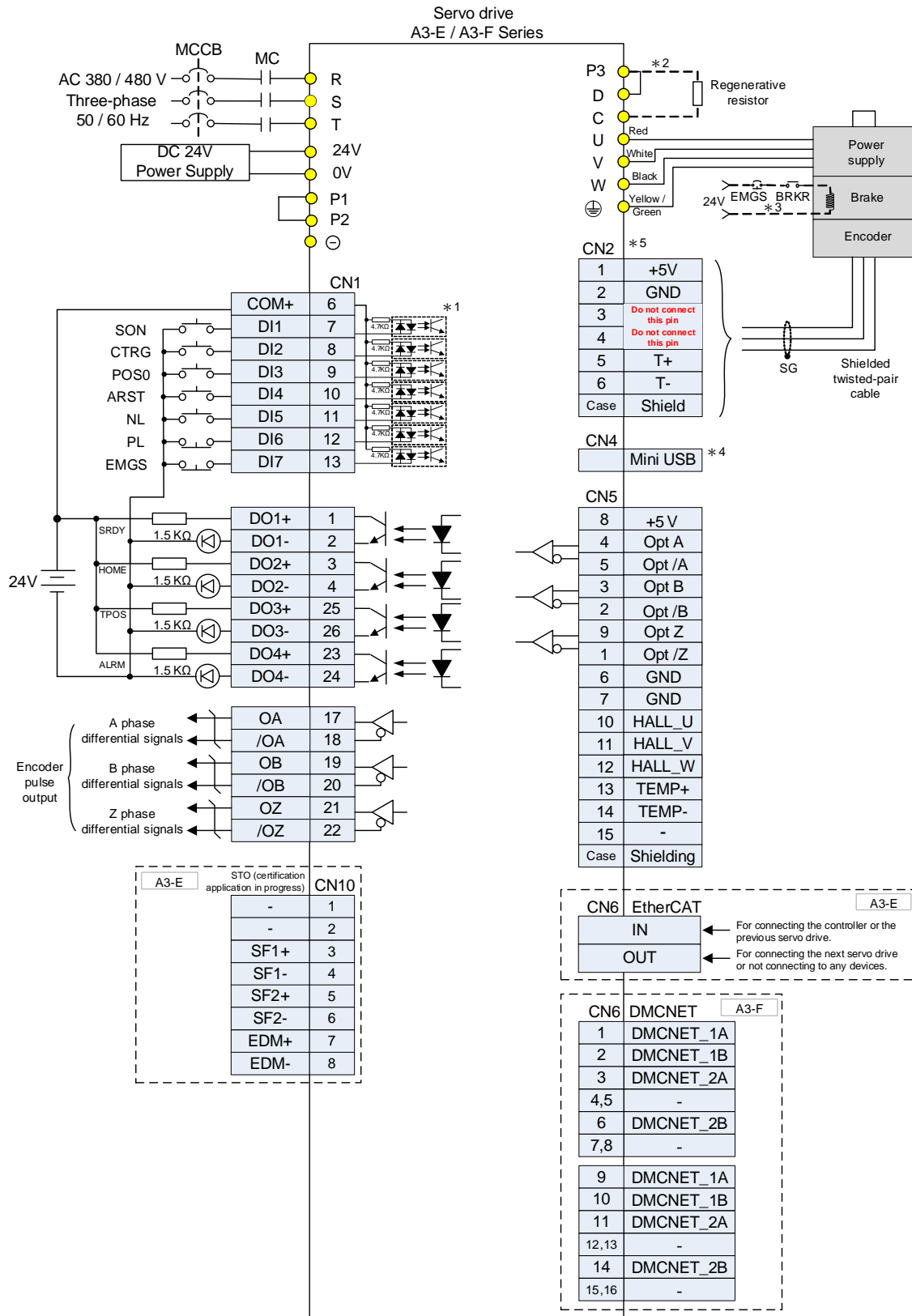

Note:

- \*1. Refer to Section 3.4.2.3 for wiring diagrams C7 SINK / C8 SOURCE.
- \*2. Only models of 1.5 kW and below have built-in regenerative resistors.
- \*3. The brake coil has no polarity.
- \*4. Connects to the Mini-USB connector (for PC communication).
- \*5. The CN2 wiring in the figure is for a Delta communication type motor. Refer to Chapter 11 for the wiring instructions of third-party motors.

### 3.12.4 Speed (S) control mode

3

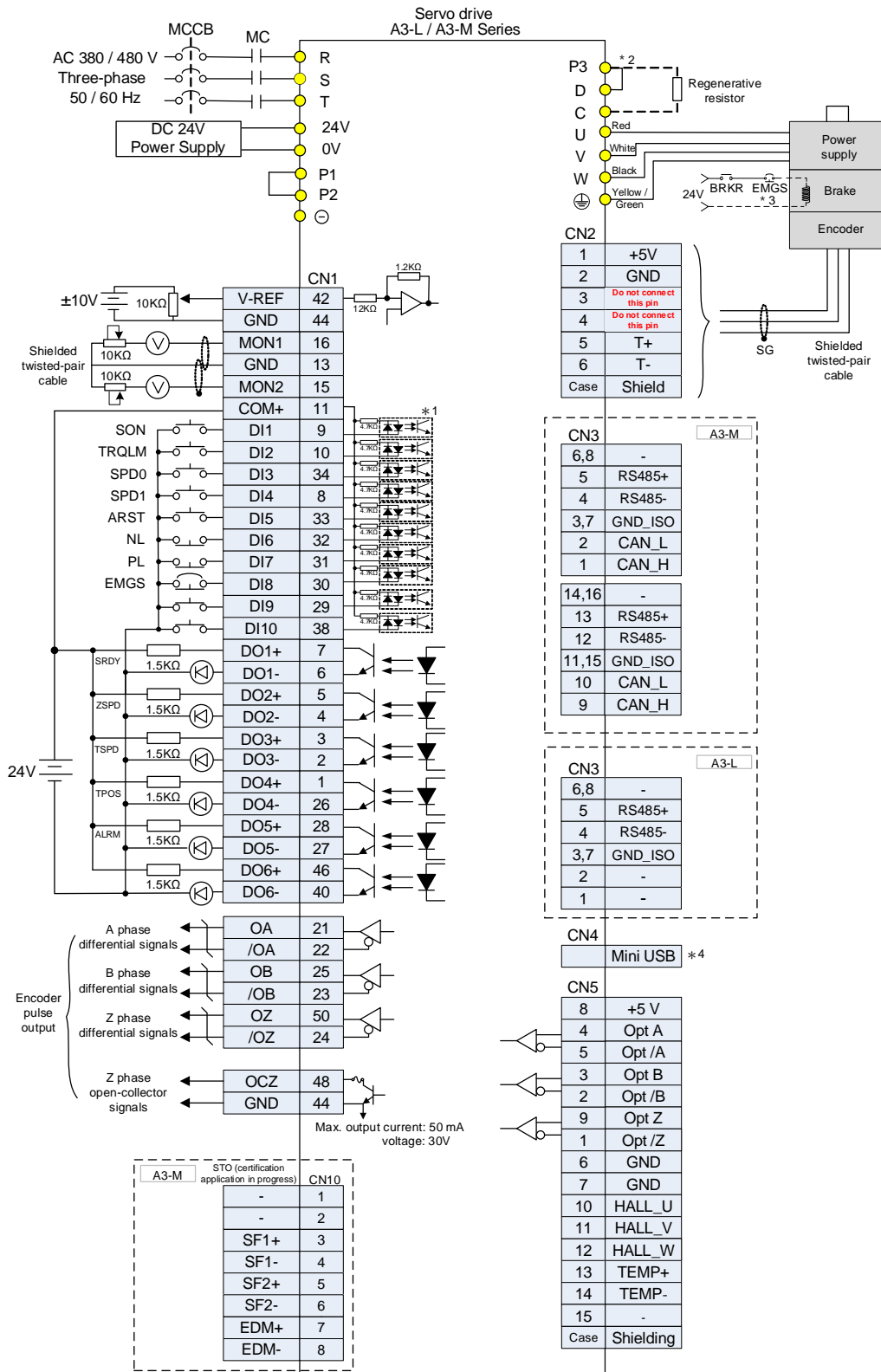

Note:

- \*1. Refer to Section 3.4.1.3 for wiring diagrams C7 SINK / C8 SOURCE.
- \*2. Only models of 1.5 kW and below have built-in regenerative resistors.
- \*3. The brake coil has no polarity.
- \*4. Connects to the Mini-USB connector (for PC communication).
- \*5. The CN2 wiring in the figure is for a Delta communication type motor. Refer to Chapter 11 for the wiring instructions of third-party motors.

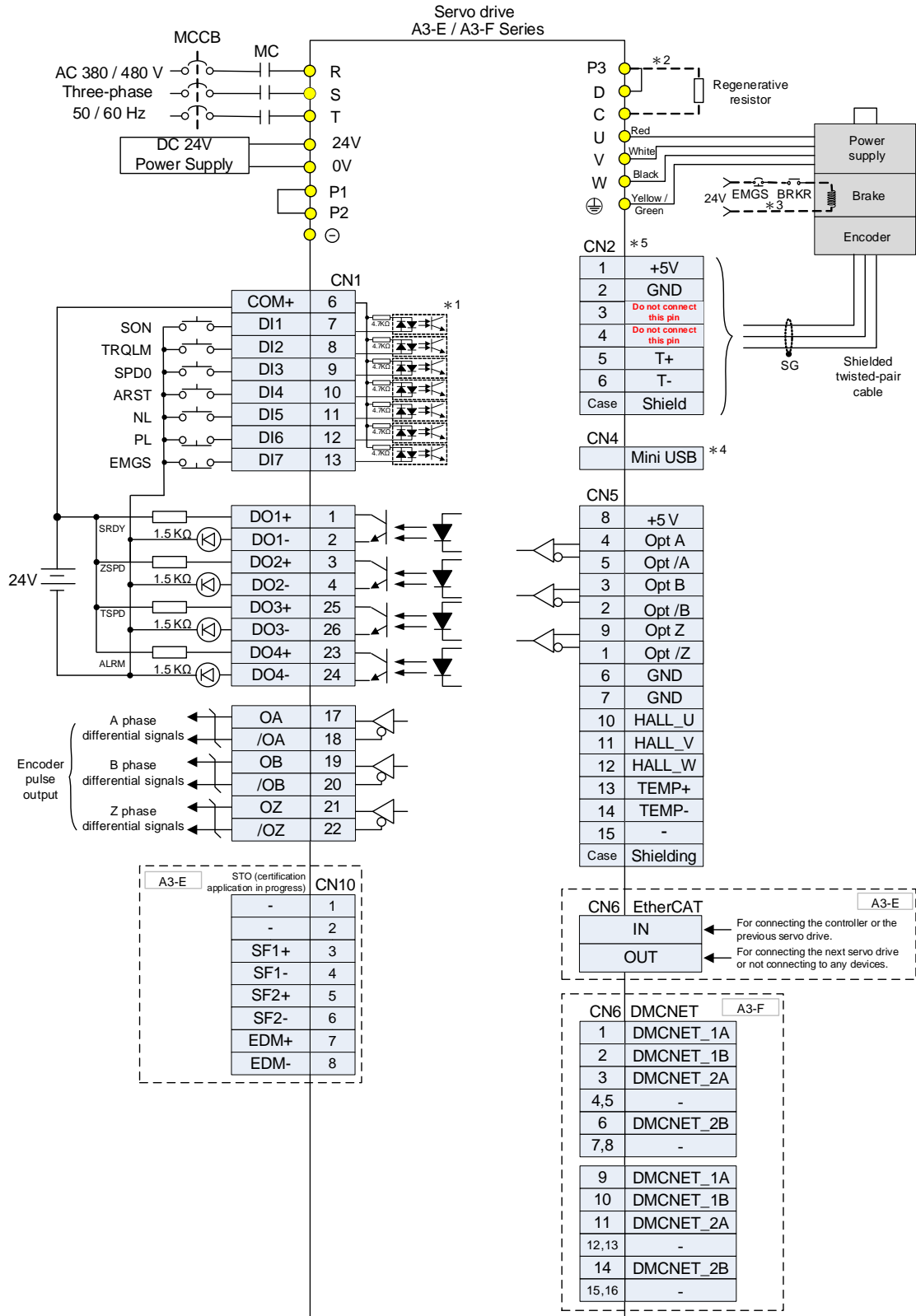

Note:

- \*1. Refer to Section 3.4.2.3 for wiring diagrams C7 SINK / C8 SOURCE.
- \*2. Only models of 1.5 kW and below have built-in regenerative resistors.
- \*3. The brake coil has no polarity.
- \*4. Connects to the Mini-USB connector (for PC communication).
- \*5. Models of 1.5 kW and below can use single-phase power supply.
- \*6. The CN2 wiring in the figure is for a Delta communication type motor. Refer to Chapter 11 for the wiring instructions of third-party motors.

### 3.12.5 Torque (T) control mode

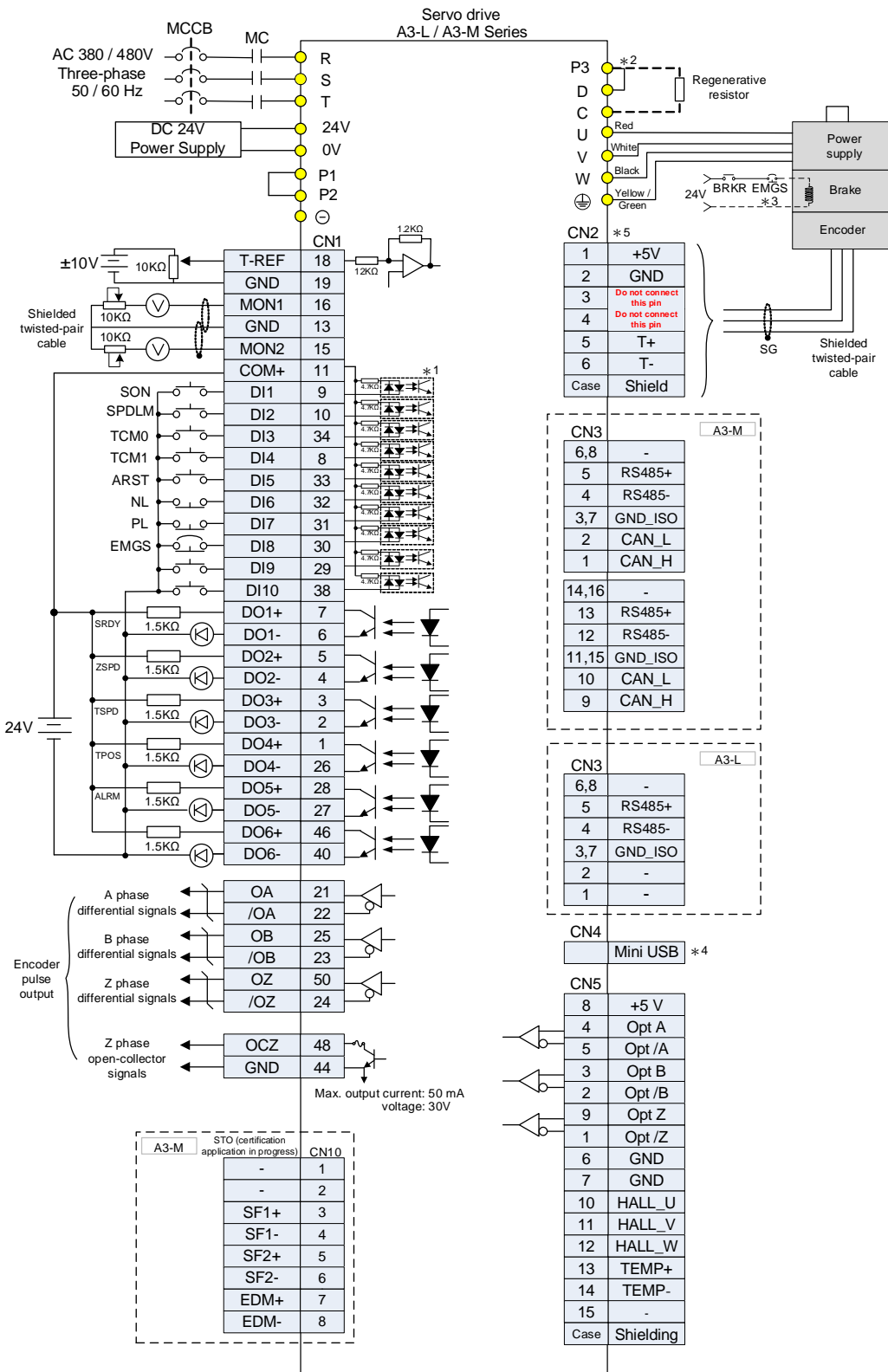

Note:

- \*1. Refer to Section 3.4.1.3 for wiring diagrams C7 SINK / C8 SOURCE.
- \*2. Only models of 1.5 kW and below have built-in regenerative resistors.
- \*3. The brake coil has no polarity.
- \*4. Connects to the Mini-USB connector (for PC communication).
- \*5. The CN2 wiring in the figure is for a Delta communication type motor. Refer to Chapter 11 for the wiring instructions of third-party motors.

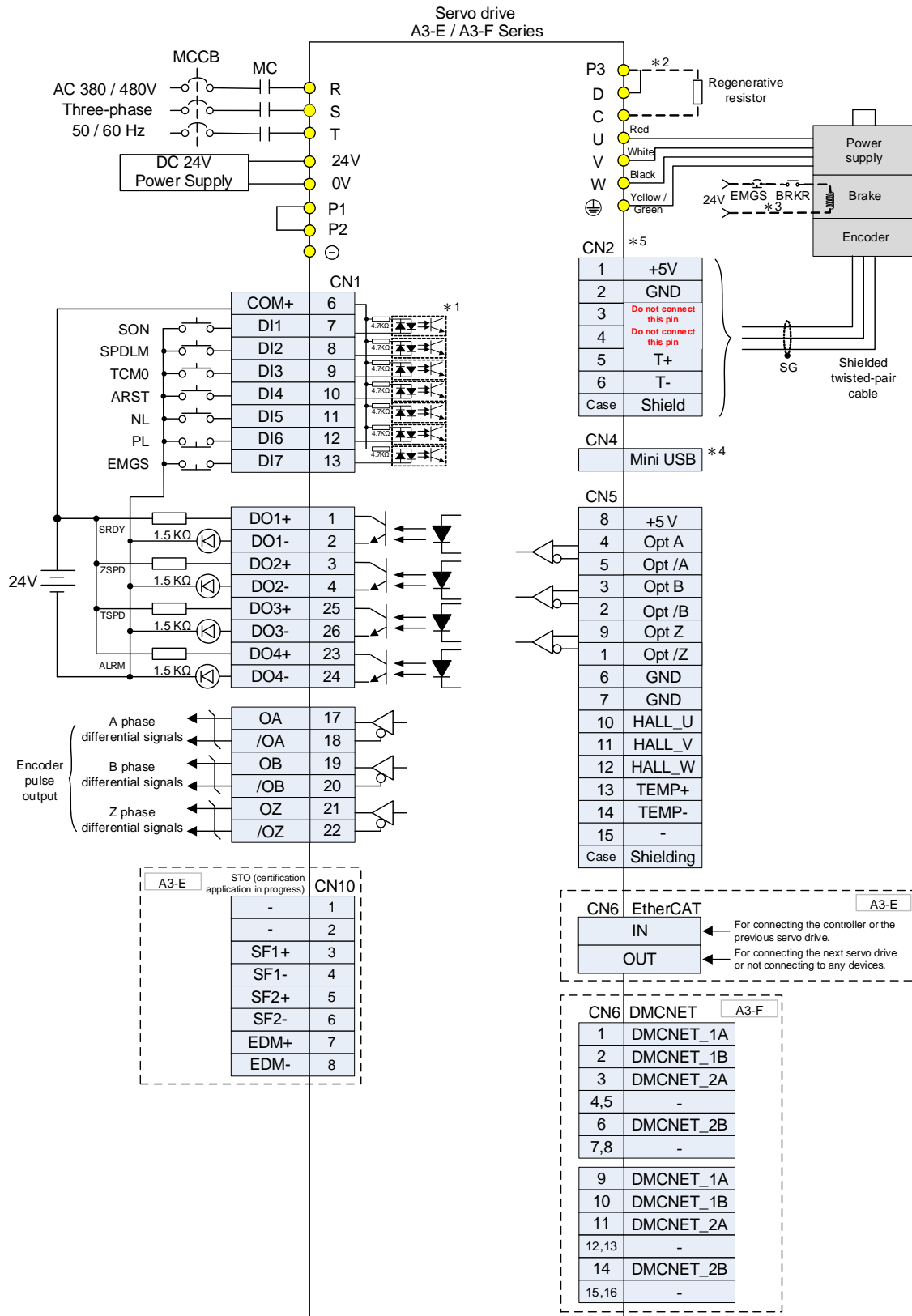

Note:

- \*1. Refer to Section 3.4.2.3 for wiring diagrams C7 SINK / C8 SOURCE.
- \*2. Only models of 1.5 kW and below have built-in regenerative resistors.
- \*3. The brake coil has no polarity.
- \*4. Connects to the Mini-USB connector (for PC communication).
- \*5. The CN2 wiring in the figure is for a Delta communication type motor. Refer to Chapter 11 for the wiring instructions of third-party motors.



### 3.12.6 Communication mode (CANopen)

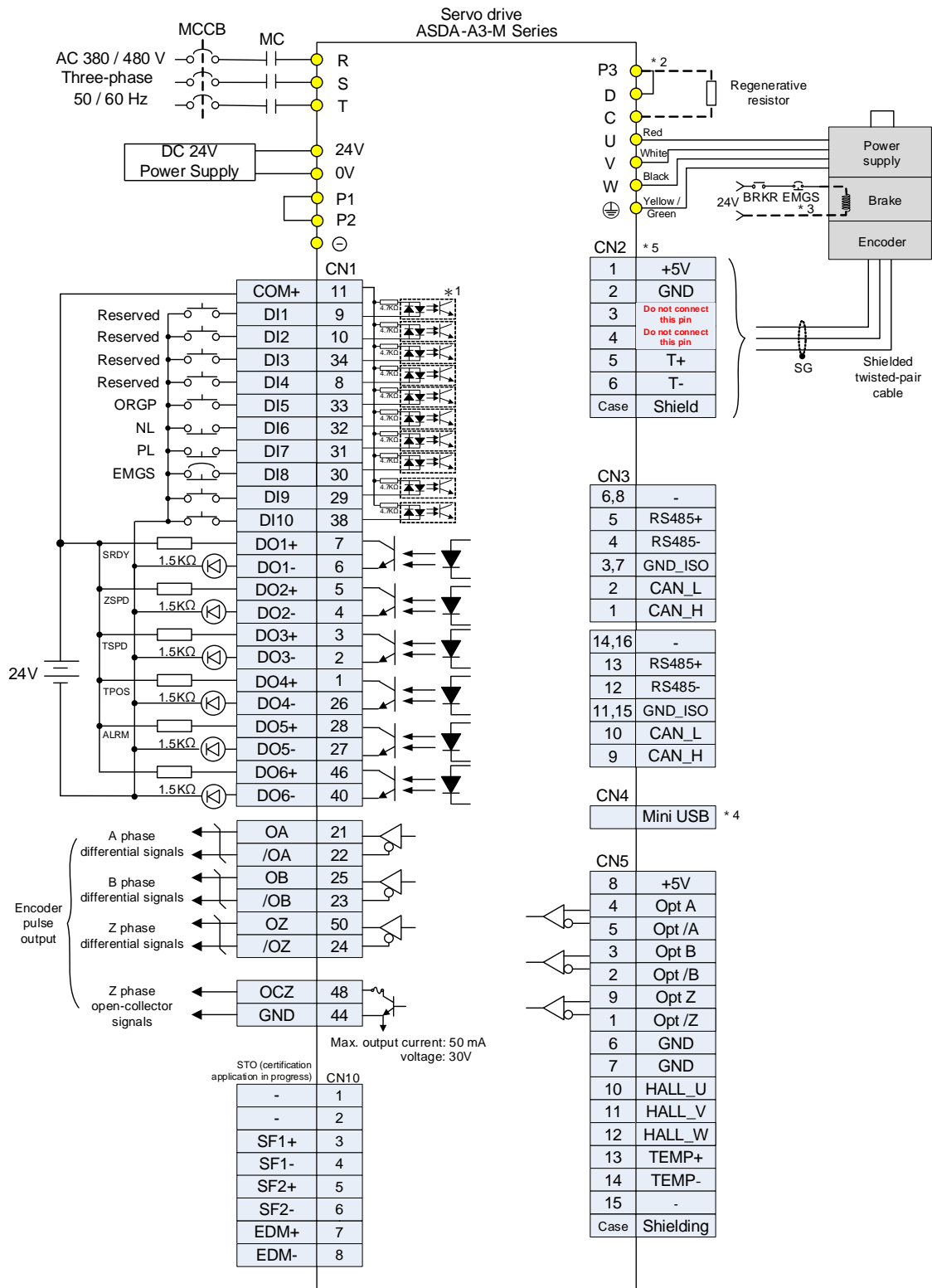

Note:

- \*1. Refer to Section 3.4.1.3 for wiring diagrams C7 SINK / C8 SOURCE.
- \*2. Only models of 1.5 kW and below have built-in regenerative resistors.
- \*3. The brake coil has no polarity.
- \*4. Connects to the Mini-USB connector (for PC communication).
- \*5. The CN2 wiring in the figure is for a Delta communication type motor. Refer to Chapter 11 for the wiring instructions of third-party motors.

### 3.12.7 Communication mode (DMCNET)

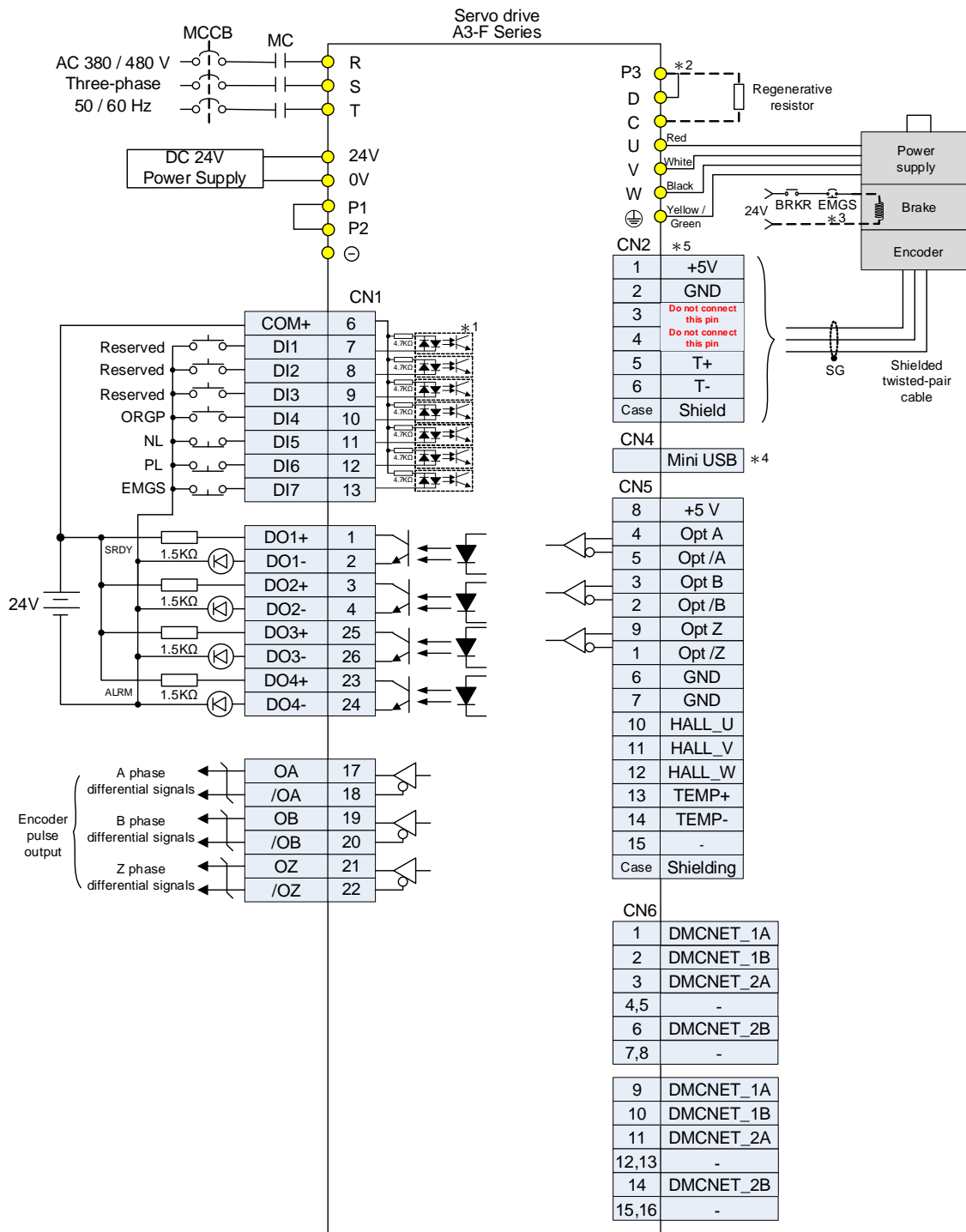

Note:

- \*1. Refer to Section 3.4.2.3 for wiring diagrams C7 SINK / C8 SOURCE.
- \*2. Only models of 1.5 kW and below have built-in regenerative resistors.
- \*3. The brake coil has no polarity.
- \*4. Connects to the Mini-USB connector (for PC communication).
- \*5. The CN2 wiring in the figure is for a Delta communication type motor. Refer to Chapter 11 for the wiring instructions of third-party motors.

3

3

### 3.12.8 Communication mode (EtherCAT)

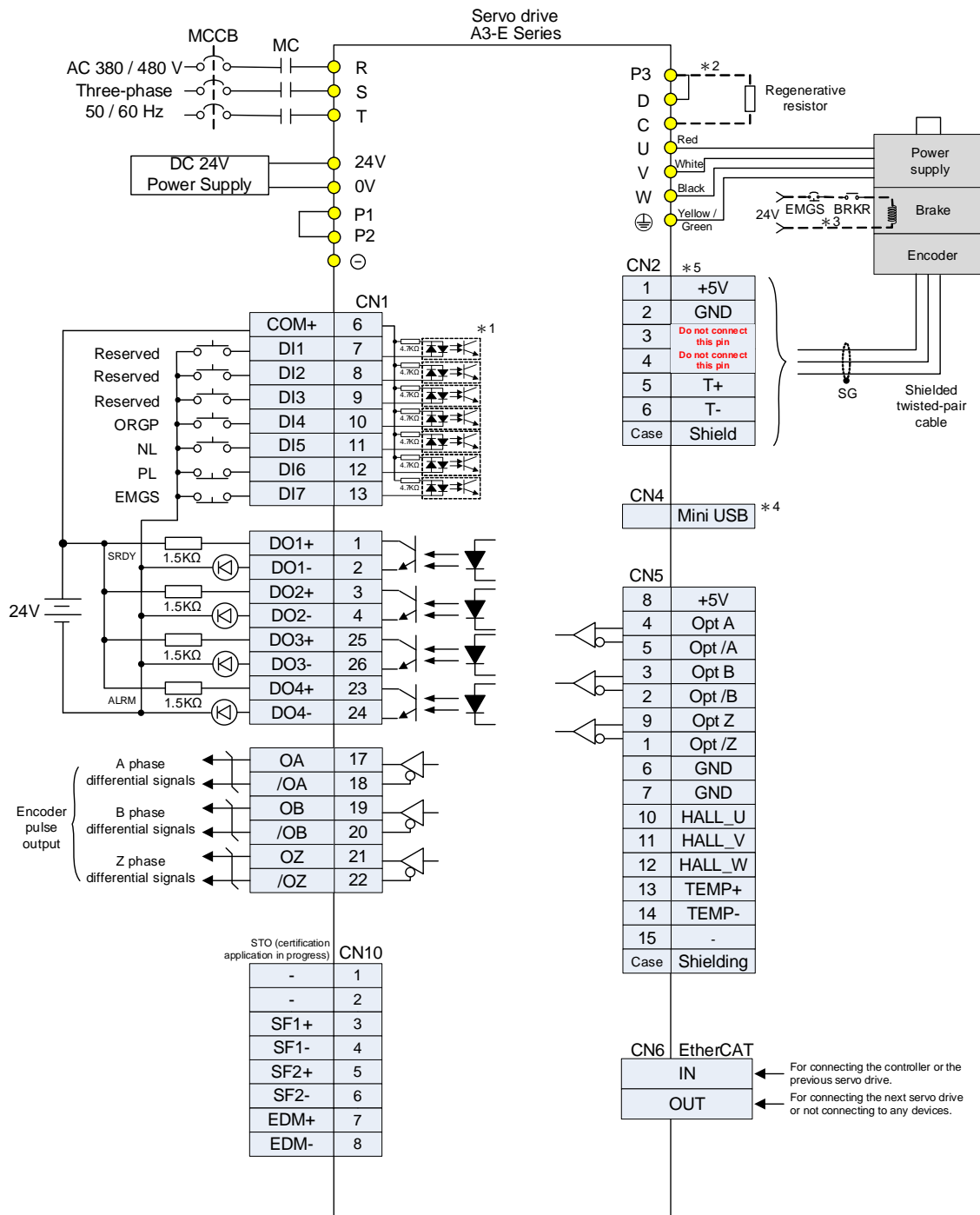

Note:

- \*1. Refer to Section 3.4.2.3 for wiring diagrams C7 SINK / C8 SOURCE.
- \*2. Only models of 1.5 kW and below have built-in regenerative resistors.
- \*3. The brake coil has no polarity.
- \*4. Connects to the Mini-USB connector (for PC communication).
- \*5. The CN2 wiring in the figure is for a Delta communication type motor. Refer to Chapter 11 for the wiring instructions of third-party motors.

# Test Operation and Panel Display

# 4

This chapter describes the panel display of ASDA-A3 series servo drive, as well as its operation and testing.

---

4.1	Panel description	4-2
4.2	Parameter setting procedure	4-3
4.3	Status display	4-6
4.3.1	Data save status	4-6
4.3.2	Decimal points	4-6
4.3.3	Alarm messages	4-7
4.3.4	Positive and negative sign setting	4-7
4.3.5	Monitoring display	4-7
4.4	General functions	4-11
4.4.1	Operation of fault record display	4-11
4.4.2	Force DO on	4-12
4.4.3	Digital input diagnosis operation	4-13
4.4.4	Digital output diagnosis operation	4-13
4.5	Testing	4-14
4.5.1	Testing without load	4-14
4.5.2	Apply power to A3 servo drive	4-15
4.5.3	JOG trial run without load	4-20
4.5.4	Trial run without load (Speed mode)	4-22
4.5.5	Trial run without load (Position mode)	4-24

## 4.1 Panel description

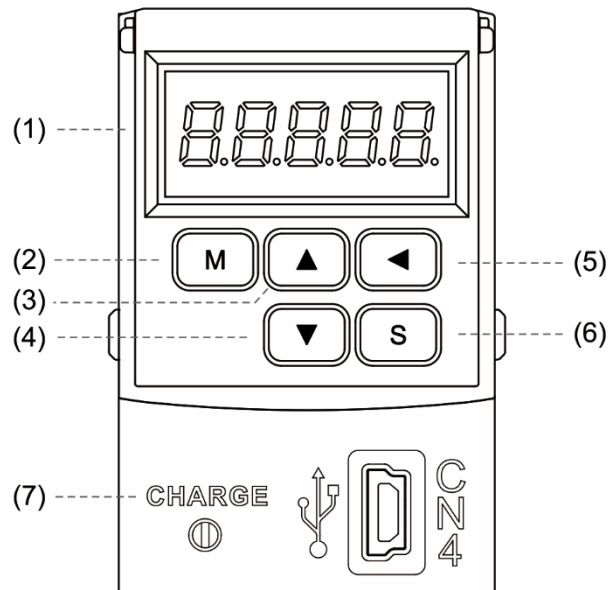

- (1) Display: 5-digit, 7-segment LED displays the monitoring values, parameter numbers, and setting values.
- (2) MODE key (M): switches the display among Monitoring mode, Parameter mode, and Alarm mode. In Editing mode, press the MODE key to switch back to Parameter mode.
- (3) UP key (▲): changes monitoring code, parameter number, and setting value.
- (4) DOWN key (▼): changes monitoring code, parameter number, and setting value.
- (5) SHIFT key (◀): in Parameter mode, press this key to change the group number. In Editing mode, moving the flashing (selected) digit to the left lets you adjust the higher setting bit. In Monitoring mode, you can switch the display of high / low digits.
- (6) SET key (S): displays and stores the parameter setting value. In Monitoring mode, pressing the SET key switches between decimal and hexadecimal display. In Parameter mode, pressing the SET key switches to Editing mode.
- (7) Charge LED: the Charge LED indicator is on when the power is applied to the circuit.

## 4.2 Parameter setting procedure

Switching modes:

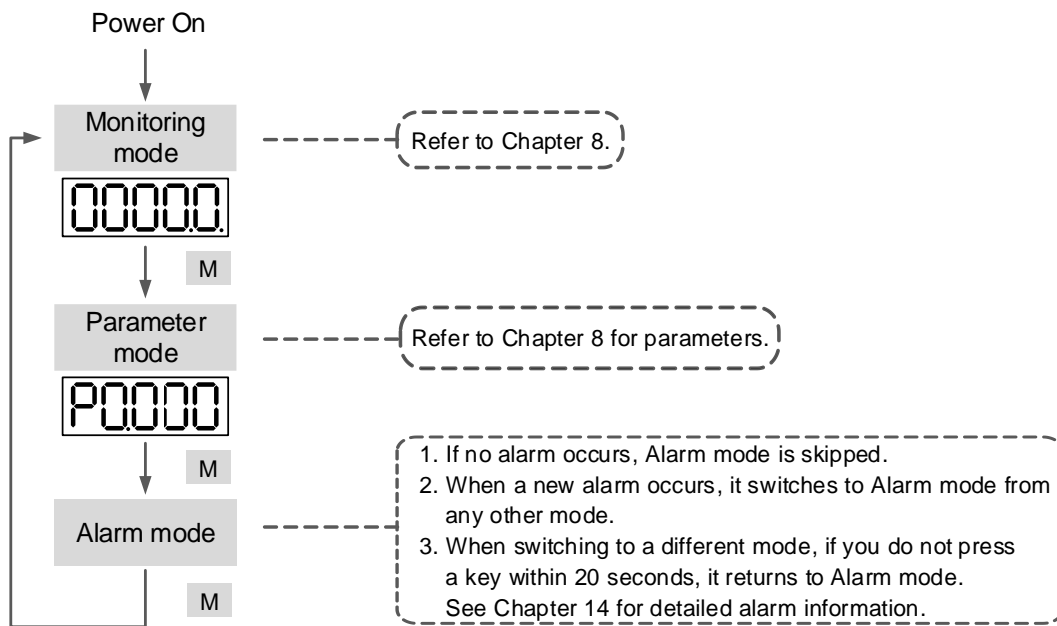

Operating in each mode:

### Monitoring mode

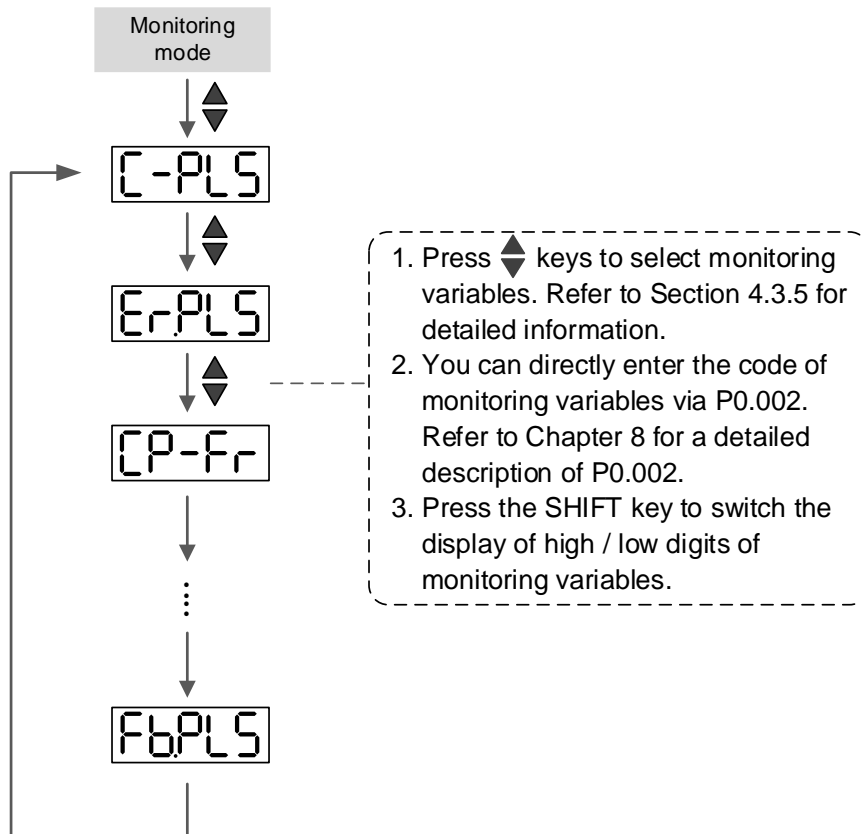

# 4

## Parameter mode

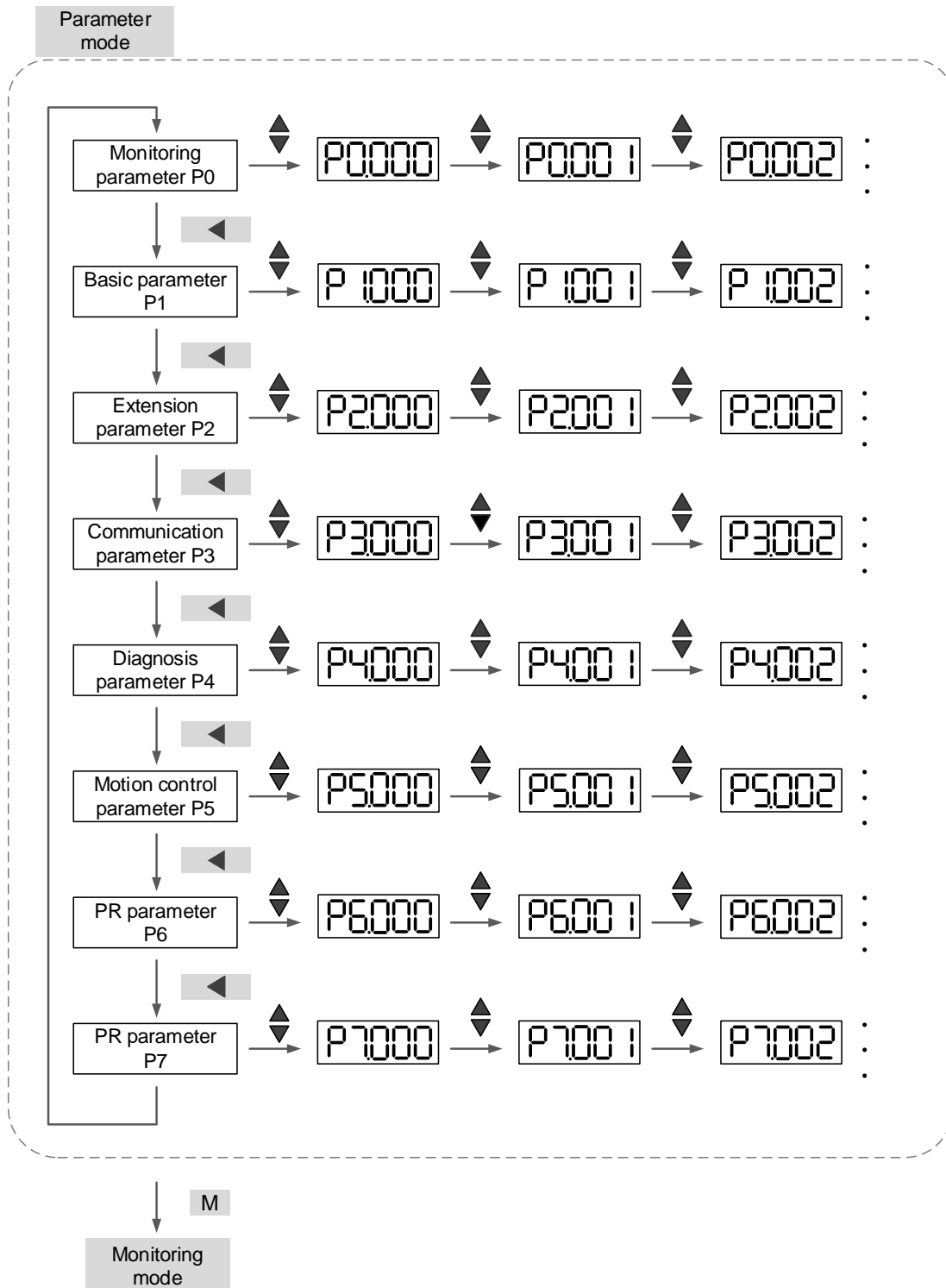

Editing mode

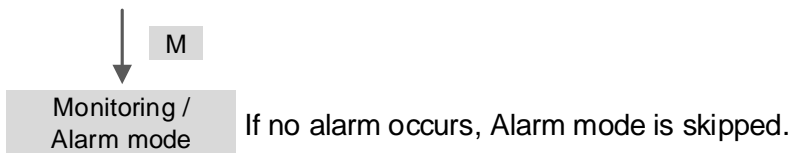
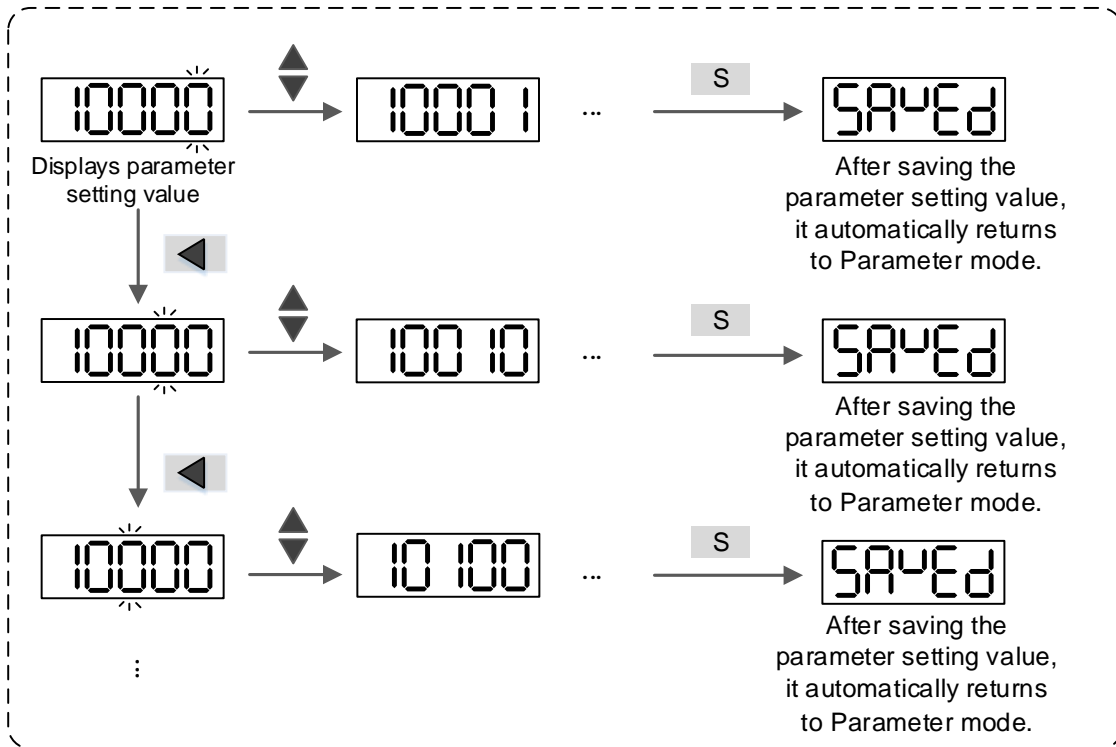
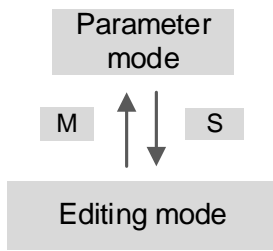





4

### 4.3 Status display

#### 4.3.1 Data save status

When you complete the parameter setting, press the SET key to save the parameters.

The panel displays the status for one second.

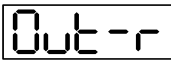
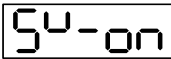
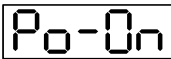
Displayed symbol	Description
	Correctly saved the setting value (Saved).
	Read-only and write-protected parameter (Read-only).
	Entered the wrong password or did not enter a password (Locked).
	Entered an incorrect setting value or the reserved setting value (Out of Range).
	You cannot enter a value when in the Servo On state (Servo On).
	Changes to the parameter take effect after power cycling of the servo drive (Power On).

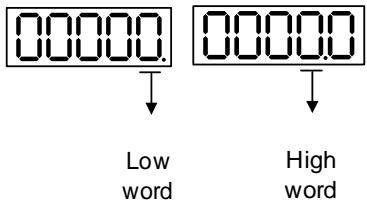
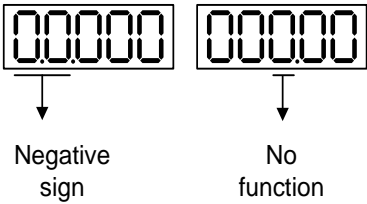

#### 4.3.2 Decimal points

Displayed symbol	Description
	High word / low word indication: this indicates the current high word or low word when the data is displayed in decimal format (32 bits).
	Negative sign: the two decimal points on the left represent the negative sign when the data is displayed in decimal format (16 or 32 bits). In hexadecimal format, it only shows positive values.

### 4.3.3 Alarm messages

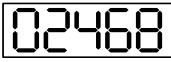

Displayed symbol	Description
	When an alarm occurs, the panel displays 'AL' as the alarm symbol and 'nnn' as the alarm code. Refer to Chapter 8 Parameters for a detailed description of P0.001 or Chapter 14 Troubleshooting for alarm details.

### 4.3.4 Positive and negative sign setting

Displayed symbol	Description
	In Editing mode, press the UP (▲) and DOWN (▼) keys to change the displayed value. Press the SHIFT key to change the selected value (the selected value is flashing).
	Press the SHIFT key for 2 seconds to switch between the positive (+) and negative (-) signs. If the parameter value is out of range after the positive or negative sign is switched, then the servo drive automatically resets it to the original value.



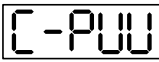
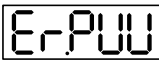

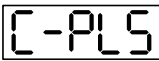
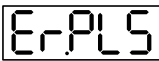
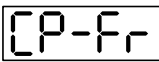
### 4.3.5 Monitoring display

When you apply power to the drive, the display shows the monitoring symbol for one second, and then enters Monitoring mode. In Monitoring mode, press the UP (▲) and DOWN (▼) keys to change the monitoring variables. Or you can directly change the setting value of P0.002 to specify the monitoring code. When the drive is powered, the default monitoring code is set to the value of P0.002. For example, if the value of P0.002 is 4, when the drive is powered, the panel displays the monitoring symbol C-PLS first, and then displays the input number of pulse commands. Refer to the following table for more information. For all monitoring variables, refer to Table 8.3 Monitoring variables descriptions in Section 8.3.



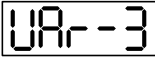

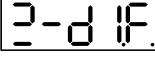
P0.002 setting value	Monitoring symbol	Description	Unit
0		Motor feedback pulse number (after the scaling of E-Gear ratio) (user unit)	[user unit]
1		Input number of pulse commands (after the scaling of E-Gear ratio) (user unit)	[user unit]
2		The deviation between control command pulse and feedback pulse number (user unit)	[user unit]
3		Motor feedback pulse number (encoder unit)	[pulse]
4		Input number of pulse commands (before the scaling of E-Gear ratio) (encoder unit)	[pulse]
5		Error pulse number (after the scaling of E-Gear ratio) (encoder unit)	[pulse]
6		Input frequency of pulse commands	[Kpps]

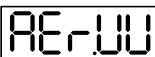
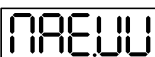
4

P0.002 setting value	Monitoring symbol	Description	Unit
7		Motor speed	[rpm]
8		Speed command	[Volt]
9		Speed command	[rpm]
10		Torque command	[Volt]
11		Torque command	[%]
12		Average torque	[%]
13		Peak torque	[%]
14		Main circuit voltage	[Volt]
15		Load / motor inertia ratio Note: if it shows 13.0, it means the load inertia ratio is 13.	[1 times]
16		IGBT temperature	[°C]
17		Resonance frequency (low word is the first resonance and high word is the second one).	[Hz]
18	 	The absolute pulse number of encoder Z phase equals the homing value, 0. It is +5000 or -4999 pulses when the motor rotates in the forward or reverse direction.	-
19		Mapping parameter #1: shows the content of parameter P0.025 (Specify the mapping target by P0.035)	-
20		Mapping parameter #2: shows the content of parameter P0.026 (Specify the mapping target by P0.036)	-
21		Mapping parameter #3: shows the content of parameter P0.027 (Specify the mapping target by P0.037)	-
22		Mapping parameter #4: shows the content of parameter P0.028 (Specify the mapping target by P0.038)	-
23		Monitoring variable #1: shows the content of parameter P0.009 (Specify the monitoring variable code by P0.017)	-
24		Monitoring variable #2: shows the content of parameter P0.010 (Specify the monitoring variable code by P0.018)	-

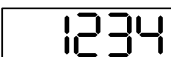
P0.002 setting value	Monitoring symbol	Description	Unit
25		Monitoring variable #3: shows the content of parameter P0.011 (Specify the monitoring variable code by P0.019)	-
26		Monitoring variable #4: shows the content of parameter P0.012 (Specify the monitoring variable code by P0.020)	-
27		Offset value between motor position and Z phase. (Only available for Delta CNC controllers.)	PUU
28		The alarm code (in decimal). The value being converted to the hexadecimal notation is identical to the alarm code displayed in P0.001 and the error code of communication models.	-
29		Position feedback from the auxiliary encoder.	PUU
30		Position difference between the position feedback and the command from the auxiliary encoder.	PUU
31		Feedback position difference between the main encoder and auxiliary encoder.	PUU

The following table shows the panel display of 16-bit and 32-bit values.

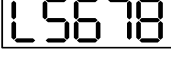
Example of the displayed value	Description	
 (Dec)	16 bits	If the value is 1234, it displays 01234 (in decimal format).
 (Hex)		If the value is 0x1234, it displays 1234 (in hexadecimal format; the first digit does not show).
 (Dec high)	32 bits	If the value is 1234567890, the display of the high word is 1234.5 and the display of the low word is 67890 (in decimal format).
 (Dec low)		
 (Hex high)		If the value is 0x12345678, the display of the high word is h1234 and the display of the low word is L5678 (in hexadecimal format).
 (Hex low)		

The following table shows the panel display for the negative sign.

Example of the displayed value	Description
	If the value is -12345, it displays as 1.2.345 (only in decimal format; there is no positive or negative sign for hexadecimal format display).

Note:

1. Dec means the value is displayed in decimal format; Hex means the value is displayed in hexadecimal format.
2. The display shown above is applicable in both Monitoring mode and Editing mode.
3. All monitoring variables are 32 bits, and you can switch the high / low word and the display method (Dec / Hex). As described in Chapter 8, each parameter only supports one display method and switching the display method is not allowed.

4

### 4.4 General functions

#### 4.4.1 Operation of fault record display

In Parameter mode, select P4.000 - P4.004 and press the SET key to show the corresponding fault records.

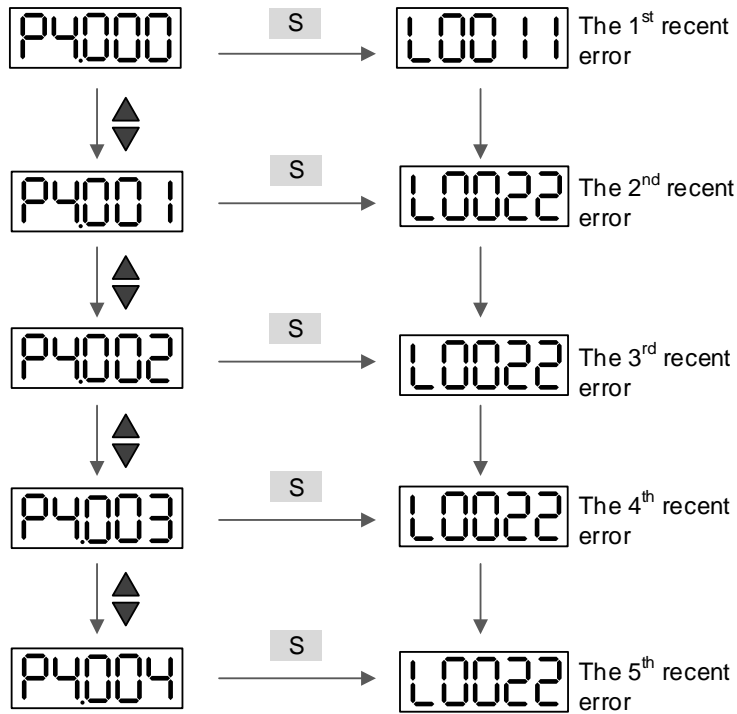

4

4.4.2 Force DO on

You can switch to the Diagnosis mode by the following steps. Set P2.008 to 406 to force enable the DO mode. Then, set the DO by binary method with P4.006. When the parameter value is 2, it forces DO2 on. When the value is 5, it forces DO1 and DO3 on. No data is retained in this mode. The mode returns to the normal DO mode after power cycling of the drive. You can also set P2.008 to 400 to switch to the normal DO mode.

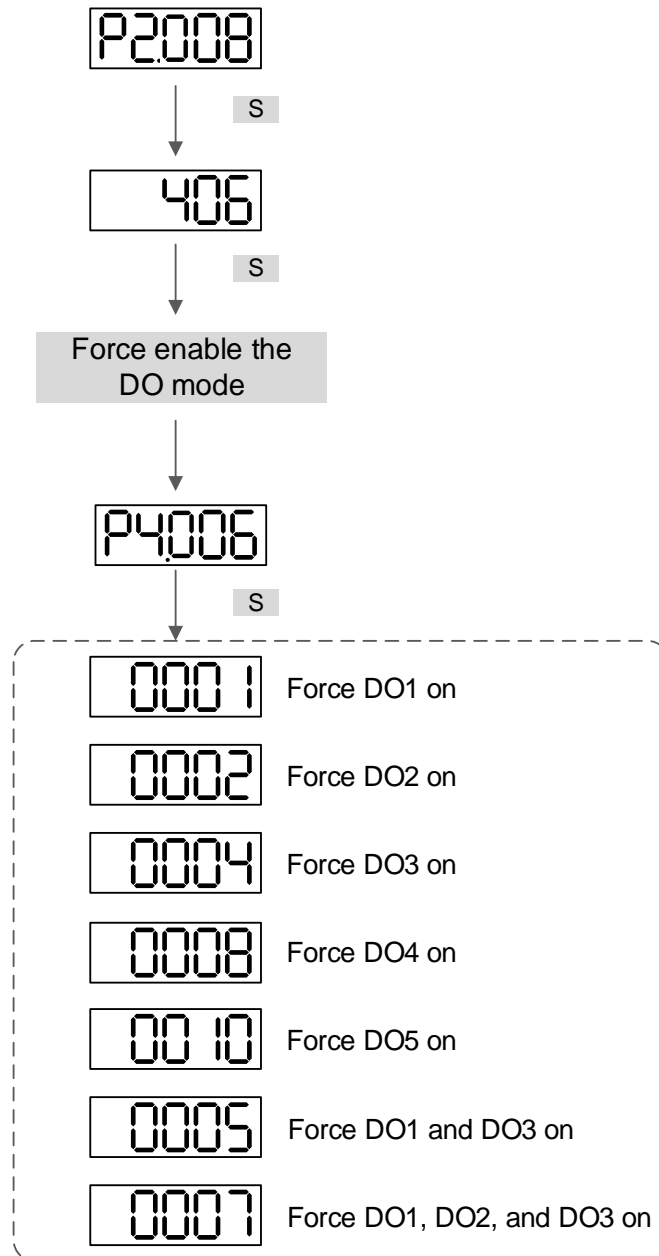

Note: P4.006 is displayed in hexadecimal format. Therefore, it does not show the fifth 0.

### 4.4.3 Digital input diagnosis operation

You can switch to the Diagnosis mode by the following steps. When DI1 - DI10 are triggered by the external signal, the panel shows the corresponding signal in bit. When it shows 1, it means the DI is on.

For example, if it shows 1FE1, E is in hexadecimal format; it will be 1110 when it transfers to binary format. Then, DI6 - DI8 are on.

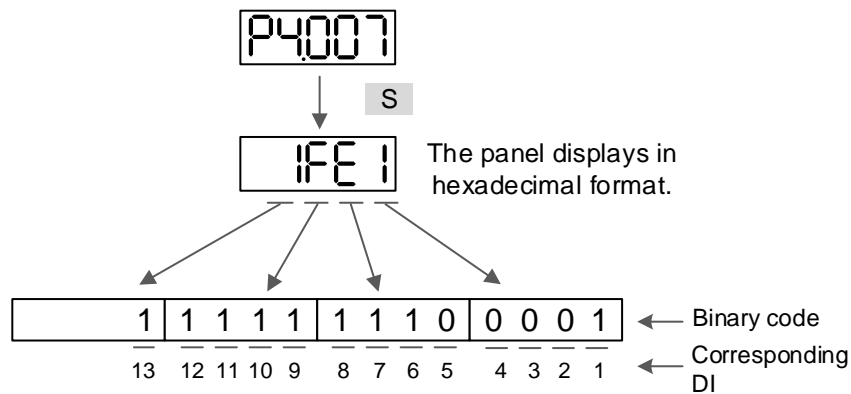

### 4.4.4 Digital output diagnosis operation

You can switch to the Diagnosis mode by the following steps. When DO1 - DO5 are triggered by the output signal, the panel shows the corresponding signal in bit. When it shows 1, it means the DO is on.

For example, if it shows 1F, F is in hexadecimal format; it will be 1111 when it transfers to binary format. Then, DO1 - DO4 are on.

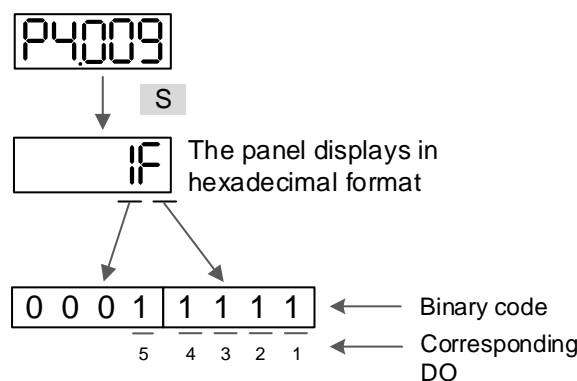



4

## 4.5 Testing

This section is divided into two parts. The first part introduces testing without load and the second part describes testing when the servo motor is running with load. To avoid danger, operate the servo motor without load first.

### 4.5.1 Testing without load

Remove the load from the servo motor, including coupling on the shaft and accessories, to avoid any damage to the servo drive or machine. This prevents the parts on the motor shaft from falling off and possibly causing personnel injury or equipment damage during operation. Run the motor without load first to see if the servo motor can run during normal operation.

**Caution:** to prevent danger, it is strongly recommended that you check if the motor can operate normally without load first. Then, try operating the motor with load.

Check the following items carefully before operation.

<p>Inspection before operation (without power)</p>	<ul style="list-style-type: none"> <li>■ Check for any obvious visible damage.</li> <li>■ The wires at the wiring terminal should be isolated.</li> <li>■ Make sure the wiring is correct to avoid damage or any abnormal operation.</li> <li>■ Check for and remove any electrically conductive objects, including sheet metal and screws, or inflammable objects inside or near the servo drive.</li> <li>■ Check if the control switch is in the Off state.</li> <li>■ Do not place the servo drive or external regenerative resistor on inflammable objects.</li> <li>■ To ensure the electromagnetic brake works, check if the stop and circuit breaker functions are working normally.</li> <li>■ Reduce the electromagnetic interference if there is electromagnetic interference with the peripheral devices.</li> <li>■ Make sure the external voltage level of the servo drive is correct.</li> </ul>
<p>Inspection during operation (power is applied)</p>	<ul style="list-style-type: none"> <li>■ Protect the encoder cable from excessive stress. When the motor is running, make sure the cable is not worn or stretched.</li> <li>■ Contact Delta if the servo motor vibrates or makes unusual noise during operation.</li> <li>■ Make sure the settings for the parameters are correct. Different machinery has different characteristics. Adjust the parameters according to the characteristics of each machine.</li> <li>■ Reset the parameters when the servo drive is in the Servo Off state, or it may cause malfunction.</li> <li>■ If there is no contact noise or other abnormal noise when the relay is operating, please contact Delta.</li> <li>■ Check if the power indicator and LED display work properly.</li> <li>■ The 7.5 kW model is controlled by PWM. When the temperature is lower than 40°C (104°F), the fan stops running.</li> </ul>

## 4.5.2 Apply power to A3 servo drive

Follow the steps.

1. Make sure the wiring between the motor and servo drive is correct:
  - (1) U, V, W, and FG have to connect to the red, white, black, and green wires respectively. If the wiring is incorrect, the motor cannot work properly. The motor ground cable FG must connect to the drive's ground terminal. Refer to Sections 3.1 - 3.2 for wiring.
  - (2) The encoder cable for the motor is correctly connected to CN2: if you only want to use the JOG function, connecting CN1 and CN3 is not necessary. Refer to Section 3.5 for the wiring for CN2.

**Caution:** do not connect the power (R, S, T) to the output terminal (U, V, W) of the A3 servo drive, or it may damage the servo drive.

2. Connect the power circuit for the servo drive:  
Connect the power to the servo drive. Refer to Sections 3.1.3 and 3.2.3 for power wiring.
3. Turn on the power:  
Power supply: apply power to the control circuit (L<sub>1C</sub>, L<sub>2C</sub>) and main circuit (R, S, T).

- When the power is on, the display of the servo drive shows:

AL013

The default digital inputs (DI6 - DI8) are the signals of negative limit (NL), positive limit (PL), and emergency stop (EMGS). If DI6 - DI8 are not used, you must change the values of P2.015 - P2.017, which you can set to 0 (disable the DI function) or some other values for different functions.

- When the servo drive status displays the P0.002 setting as the motor speed (07), then the screen display shows:

SPEED  
↓  
00000

When the panel displays no text, check if the control circuit power is undervoltage.

## 4

- When the screen displays:

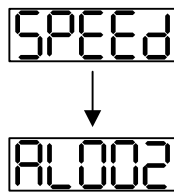

Overvoltage warning:

This means the voltage input from the main circuit is higher than the rated range or a power input error has occurred (incorrect power system).

Corrective action:

1. Use a voltmeter to measure the input voltage from the main circuit and ensure it is within the rated range.
  2. Use a voltmeter to measure if the power system complies with the specifications.
- When the screen displays:

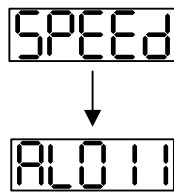

Encoder error warning:

Check that the motor encoder is securely connected and the wiring is correct.

Corrective action:

1. Make sure the wiring is following the instructions in the user manual.
2. Check the encoder connector.
3. Check for loose wiring.
4. Check for damage to the encoder.

- When the screen displays:

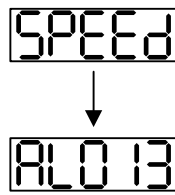

Emergency stop warning:

Check if any of the digital inputs DI1 - DI10 are set to emergency stop (EMGS).

Corrective action:

1. If you do not want to set the emergency stop (EMGS) as one of the digital inputs, make sure none of the digital inputs DI1 - DI10 are set to emergency stop (EMGS) (make sure that none of the parameters, P2.010 - P2.017, P2.036, and P2.037, are set to 21).
2. If the emergency stop (EMGS) function is needed, make sure this DI is on when it is preset as normally closed (function code: 0x0021), and then set this DI as normally open (function code: 0x0121).

- When the screen displays:

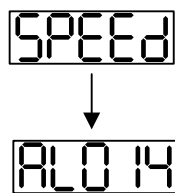

Negative limit error warning:

Check if any of the digital inputs DI1 - DI10 are set to negative limit (NL) and that DI is not on.

Corrective action:

1. If you do not want to set the negative limit (NL) as one of the digital inputs, make sure none of the digital inputs DI1 - DI10 are set to negative limit (NL) (make sure that none of the parameters, P2.010 - P2.017, P2.036, and P2.037, are set to 22).
2. If the negative limit (NL) function is needed, make sure this DI is on when it is preset as normally closed (function code: 0x0022), and then set this DI as normally open (function code: 0x0122).

## 4

- When the screen displays:

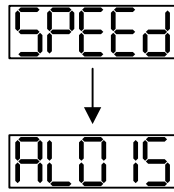

Positive limit error warning:

Check if any of the digital inputs DI1 - DI10 are set to positive limit (PL) and that DI is not on.

Corrective action:

1. If you do not want to set the positive limit (PL) as one of the digital inputs, make sure none of the digital inputs DI1 - DI10 are set to positive limit (PL) (make sure that none of the parameters, P2.010 - P2.017, P2.036, and P2.037, are set to 23).
2. If the positive limit (PL) function is needed, make sure this DI is on when it is preset as normally closed (function code: 0x0023), and then set this DI as normally open (function code: 0x0123).

- When the screen displays:



Overcurrent warning.

Corrective action:

1. Check the connection between the motor and servo drive.
2. Check if the conducting wire is short-circuited. Fix the short circuit and prevent any metal conductors from being exposed.

- When the screen displays:



Undervoltage warning.

Corrective action:

1. Check if the main circuit wiring is correct.
2. Use a voltmeter to measure if the main circuit voltage is normal.
3. Use a voltmeter to measure if the power system complies with the specifications.

Note: during power on or in the Servo On state (without any commands issued), if an alarm occurs or any abnormal display appears, please contact the distributors.

4

4.5.3 JOG trial run without load

It is easy to test the motor and servo drive using a JOG trial run without load since no extra wiring is needed. For safety reasons, it is recommended that you set JOG at low speed. Follow these steps.

Note: the JOG trial run is not supported when P1.001.X = B or C or P1.001.Y = 1.

Step 1: JOG trial run is available only when the servo drive is in the Servo On state. The drive can be forced into the Servo On state by setting P2.030 to 1 or by the controller.

Step 2: set the JOG speed (unit: rpm) with P4.005. Press the S key to display the JOG speed. The default is 20 rpm.

Step 3: press the ▲ or ▼ key to adjust the JOG speed. In the following example, the speed is set to 100 rpm.

Step 4: press the S key to display “JOG” and enter JOG mode.

Step 5: after completing the trial run, press the M key to exit JOG mode.

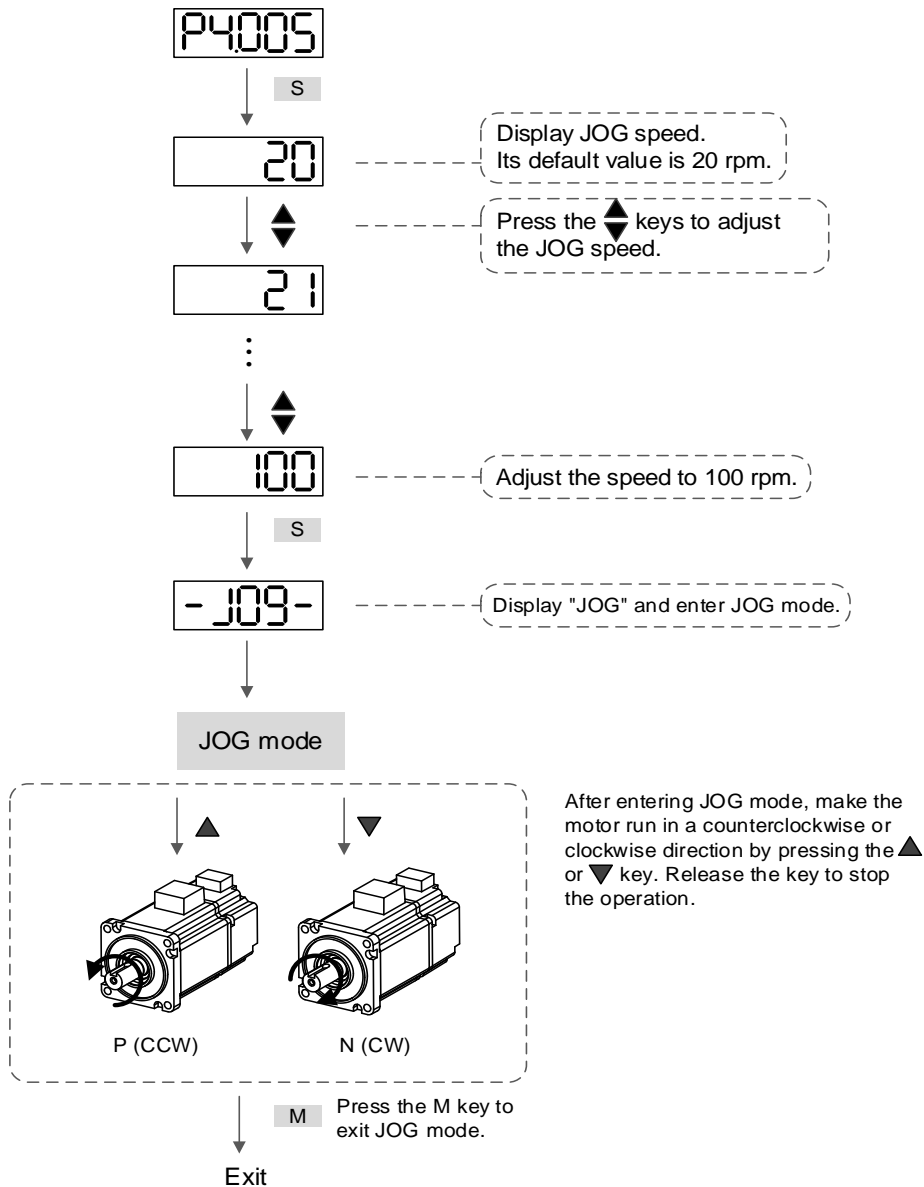

The following shows the JOG timing diagram.

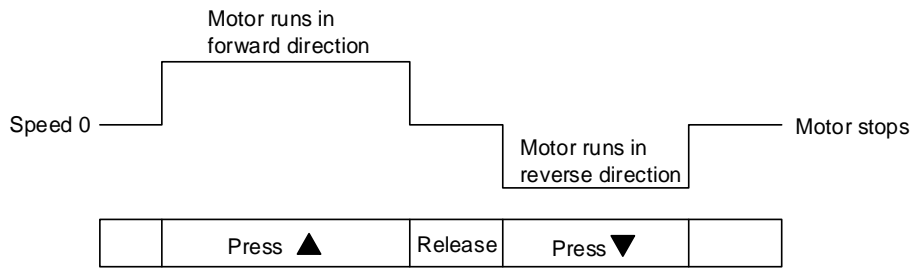

If the motor does not run, check if the wiring between U, V, W and encoder cable is correct.  
If the motor runs abnormally, check if the U, V, W phase sequence is correct.



4

**4.5.4 Trial run without load (Speed mode)**

Before starting the trial run without load, firmly secure the motor base to avoid any danger caused by the force generated by the motor during speed changes.

Step 1: set the control mode of the servo drive to Speed mode. Set P1.001 to 2 for Speed mode. Then cycle the power to the servo drive.

Step 2: in Speed mode, set the digital input settings for the trial run as shown in the following table.

Digital input	Parameter setting value	Symbol	Function description	CN1 Pin No.
DI1	P2.010 = 101	SON	Servo activated	DI1- = 9
DI2	P2.011 = 109	TRQLM	Torque limit	DI2- = 10
DI3	P2.012 = 114	SPD0	Speed selection	DI3- = 34
DI4	P2.013 = 115	SPD1	Speed selection	DI4- = 8
DI5	P2.014 = 102	ARST	Alarm reset	DI5- = 33
DI6	P2.015 = 0	-	DI disabled	-
DI7	P2.016 = 0	-	DI disabled	-
DI8	P2.017 = 0	-	DI disabled	-
DI9	P2.036 = 0	-	DI disabled	-
DI10	P2.037 = 0	-	DI disabled	-
DI11	P2.038 = 0	-	DI disabled	-
DI12	P2.039 = 0	-	DI disabled	-
DI13	P2.040 = 0	-	DI disabled	-

You can program the digital inputs of Delta’s servo drive by referring to Section 8.1 Digital input (DI) descriptions.

The default setting includes the negative limit, positive limit, and emergency stop functions; therefore, if any alarm occurs after you complete the settings, cycle the power to the servo drive or set DI5 to on to clear the alarm. Please refer to Section 4.5.

The Speed command selection is determined by SPD0 and SPD1. See the following table.

Speed command number	DI signal of CN1		Command source			Content	Range
	SPD1	SPD0	Mode	S	External analog signal		
S1	0	0	Mode	S	External analog signal	Voltage difference between V_REF and GND	-10V to +10V
				Sz	N/A	Speed command is 0	0
S2	0	1	Internal register parameter			P1.009	-75000 to +75000
S3	1	0				P1.010	-75000 to +75000
S4	1	1				P1.011	-75000 to +75000

0: means that DI is off (the circuit is open).

1: means that DI is on (the circuit is closed).

The parameter setting range of the internal register is from -75000 to +75000.

Rotation speed = setting value x unit (0.1 rpm).

For example, P1.009 = +30000, and the rotation speed = +30000 x 0.1 rpm = +3000 rpm.

Command setting for the speed register:

Set P1.009 to +30000.

Set P1.010 to +1000.

Set P1.011 to -30000.

Motor's running direction:

Input command	Rotation direction
+	CCW (forward direction)
-	CW (reverse direction)

Step 3:

- (a) Switch on DI1 and the drive is in the Servo On state.
- (b) When both DI3 (SPD0) and DI4 (SPD1) are off, that means the drive executes the S1 command. The motor rotates according to analog voltage command.
- (c) When DI3 (SPD0) is on, that means the drive executes the S2 command. The rotation speed is 3,000 rpm.
- (d) When DI4 (SPD1) is on, that means the drive executes the S3 command. The rotation speed is 100 rpm.
- (e) When both DI3 (SPD0) and DI4 (SPD1) are on, that means the drive executes the S4 command. The rotation speed is -3,000 rpm.
- (f) You can repeatedly execute steps (c), (d), and (e).
- (g) If you want to stop the motor, switch off DI1 (Servo Off).

4

**4.5.5 Trial run without load (Position mode)**

Before starting the trial run without load, firmly secure the motor base to avoid any danger caused by the force generated by the motor during speed changes.

Step 1: set the control mode of the servo drive to Position mode. Set P1.001 to 1 for Position mode. Then cycle the power to the servo drive.

Step 2: in Position mode, set the digital input settings for the trial run as shown in the following table.

Digital input	Parameter setting value	Symbol	Function description	CN1 Pin No.
DI1	P2.010 = 101	SON	Servo activated	DI1- = 9
DI2	P2.011 = 108	CTRG	Command triggered	DI2- = 10
DI3	P2.012 = 111	POS0	Position selection	DI3- = 34
DI4	P2.013 = 112	POS1	Position selection	DI4- = 8
DI5	P2.014 = 102	ARST	Alarm reset	DI5- = 33
DI6	P2.015 = 0	-	DI disabled	-
DI7	P2.016 = 0	-	DI disabled	-
DI8	P2.017 = 0	-	DI disabled	-
DI9	P2.036 = 0	-	DI disabled	-
DI10	P2.037 = 0	-	DI disabled	-
DI11	P2.038 = 0	-	DI disabled	-
DI12	P2.039 = 0	-	DI disabled	-
DI13	P2.040 = 0	-	DI disabled	-

You can program the digital inputs of Delta’s servo drive by referring to Section 8.1 Digital input (DI) descriptions.

The default setting includes the negative limit, positive limit, and emergency stop functions; therefore, if any alarm occurs after you complete the settings, cycle the power to the servo drive or set DI5 to on to clear the alarm. Please refer to Section 4.5.

Refer to Sections 3.12.3 and 3.13.3 for the wiring for Position (PR) control mode. See the following table for the 99 sets of PR and the Position commands (POS0 - POS6).

Position command	POS6	POS5	POS4	POS3	POS2	POS1	POS0	CTRG	Corresponding parameter
Homing	0	0	0	0	0	0	0	↑	P6.000
									P6.001
PR#1	0	0	0	0	0	0	1	↑	P6.002
									P6.003
...									...
PR#50	0	1	1	0	0	1	0	↑	P6.098
									P6.099
PR#51	0	1	1	0	0	1	1	↑	P7.000
									P7.001
...									...
PR#99	1	1	0	0	0	1	1	↑	P7.098
									P7.099

0: means that DI is off (the circuit is open).

1: means that DI is on (the circuit is closed).

You can set the 100 sets of PR (P6.000 - P7.099), which you can also set for absolute position commands.

(This page is intentionally left blank.)

4

# Tuning

# 5

This chapter contains information about One Touch tuning, Auto tuning, and gain adjustment modes. Advanced users can also tune the servo system in Manual mode. In addition, this chapter also describes how to deal with the mechanical resonance and noise and the adjustments for application functions.

5.1	Tuning procedure .....	5-4
5.2	Inertia (Weight) estimation .....	5-5
5.2.1	Precautions for inertia (weight) estimation .....	5-5
5.2.1.1	Rotary motor .....	5-5
5.2.1.2	Linear motor .....	5-6
5.2.2	Inertia (Weight) estimation with ASDA-Soft .....	5-7
5.2.2.1	Rotary motor .....	5-9
5.2.2.2	Linear motor .....	5-10
5.3	One Touch Tuning.....	5-11
5.3.1	Precautions for one touch tuning .....	5-12
5.3.1.1	Rotary motor .....	5-12
5.3.1.2	Linear motor .....	5-12
5.3.2	One touch tuning with ASDA-Soft .....	5-13
5.4	Auto tuning.....	5-16
5.4.1	Precautions for auto tuning .....	5-17
5.4.1.1	Rotary motor .....	5-17
5.4.1.2	Linear motor .....	5-18
5.4.2	Flowchart of auto tuning .....	5-19
5.4.3	Auto tuning through the drive panel.....	5-20
5.4.3.1	Rotary motor .....	5-20
5.4.3.2	Linear motor .....	5-21
5.4.4	Auto tuning with ASDA-Soft.....	5-22
5.4.5	Parameters related to auto tuning.....	5-29
5.4.5.1	Automatic gain adjustment level 1 (P2.105) - stiffness adjustment ...	5-29
5.4.5.2	Automatic gain adjustment level 2 (P2.106) - response adjustment ..	5-30
5.4.6	Alarms related to auto tuning.....	5-31
5.5	Gain adjustment modes .....	5-32
5.5.1	Differences between gain adjustment modes .....	5-32
5.5.2	Flowchart of gain adjustment mode.....	5-34

## 5

5.5.3	Gain adjustment mode 1 .....	5-35
5.5.4	Gain adjustment mode 2 .....	5-35
5.5.5	Gain adjustment mode 3 .....	5-36
5.5.6	Gain adjustment mode 4 .....	5-37
5.5.7	Gain adjustment mode 5 .....	5-38
5.5.8	Gain adjustment mode 6 .....	5-38
5.5.9	Parameters related to gain adjustment modes.....	5-39
5.5.9.1	Bandwidth response level (P2.031) - stiffness adjustment .....	5-39
5.5.9.2	Command response gain (P2.089) - response adjustment .....	5-40
5.5.9.3	Bandwidth for speed loop response (P2.126) - bandwidth adjustment .....	5-40
5.6	Manual tuning of gain parameters .....	5-41
5.6.1	Flowchart of manual tuning in Speed mode .....	5-43
5.6.2	Flowchart of manual tuning in Position mode .....	5-44
5.6.3	Manual tuning with ASDA-Soft .....	5-45
5.7	Mechanical resonance suppression and noise elimination .....	5-46
5.7.1	Notch filter.....	5-47
5.7.1.1	Function restriction .....	5-47
5.7.1.2	Function description .....	5-47
5.7.1.3	Parameter descriptions.....	5-48
5.7.1.4	Application example .....	5-50
5.7.2	Resonance suppression low-pass filter .....	5-53
5.7.2.1	Function restriction .....	5-53
5.7.2.2	Function description .....	5-53
5.7.2.3	Application example .....	5-53
5.7.3	Speed detection filter .....	5-54
5.7.3.1	Function restriction .....	5-54
5.7.3.2	Function description .....	5-54
5.7.3.3	Application example .....	5-55
5.7.4	Low-frequency vibration suppression filter .....	5-56
5.7.4.1	Function restriction .....	5-56
5.7.4.2	Function description .....	5-56
5.7.4.3	Application example .....	5-58
5.7.5	Model-controlled vibration suppression filter .....	5-59
5.7.5.1	Restrictions of the two degree of freedom control function.....	5-59
5.7.5.2	Function description of two degree of freedom control function.....	5-60
5.7.5.3	Application example of two degree of freedom control function.....	5-61
5.7.5.4	Restrictions of vibration elimination .....	5-62
5.7.5.5	Function description of vibration elimination .....	5-62
5.7.5.6	Application example of vibration elimination .....	5-63

5.7.6	Position command filter .....	5-64
5.7.6.1	Function restriction .....	5-64
5.7.6.2	Function description .....	5-64
5.7.6.3	Application example .....	5-65
5.7.7	Speed command filter .....	5-66
5.7.7.1	Function restriction .....	5-66
5.7.7.2	Function description .....	5-66
5.7.7.3	Application example .....	5-66
5.7.8	Torque command filter .....	5-67
5.7.8.1	Function restriction .....	5-67
5.7.8.2	Function description .....	5-67
5.7.8.3	Application example .....	5-67
5.8	Application function adjustment .....	5-68
5.8.1	Adjusting position error in constant speed zone .....	5-68
5.8.1.1	Function restriction .....	5-68
5.8.1.2	Function description .....	5-68
5.8.1.3	Application example .....	5-69
5.8.2	Position overshoot adjustment .....	5-70
5.8.2.1	Function restriction .....	5-70
5.8.2.2	Function description .....	5-70
5.8.2.3	Application example .....	5-70
5.8.3	Multi-axis contour control .....	5-71
5.8.3.1	Function restriction .....	5-71
5.8.3.2	Function description .....	5-71
5.8.3.3	Application example .....	5-73
5.8.4	Gain switching .....	5-75
5.8.4.1	Function restriction .....	5-75
5.8.4.2	Function description .....	5-75
5.8.4.3	Application example .....	5-75



5

### 5.1 Tuning procedure

You can tune the servo drive by following this flowchart. First, start from **One Touch Tuning**. If you are not satisfied with the tuning results, then use **Auto Tuning**, **Gain Tuning**, and Manual mode in sequence to meet the requirements.

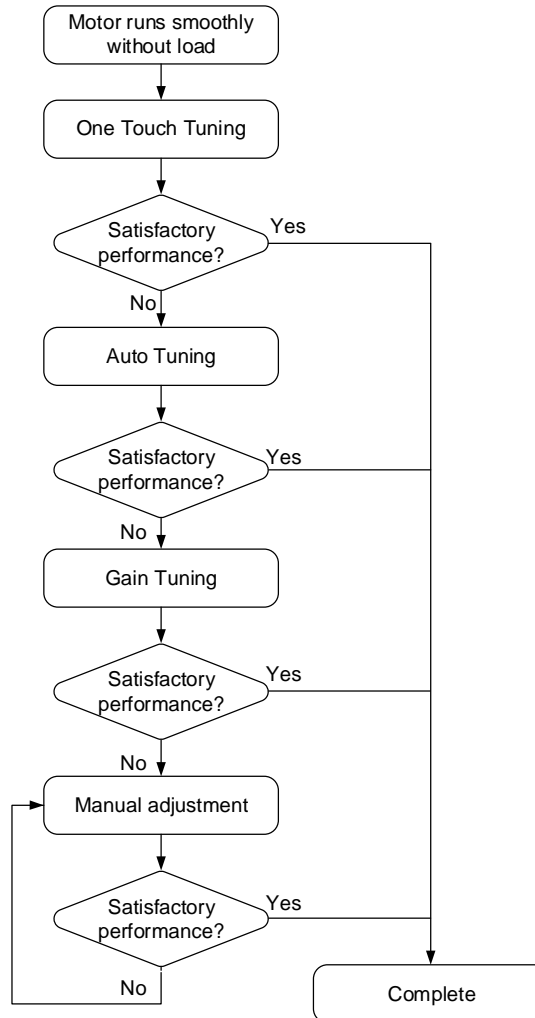

Function	Description
Inertia (Weight) estimation	When you use the functions of <b>One Touch Tuning</b> , <b>Auto Tuning</b> , or Gain adjustment mode 1 (Level adjustment - Auto) with ASDA-Soft, the servo drive automatically estimates the load inertia or weight during the tuning process. You can also perform the estimation with the <b>Inertia (Weight) Estimation</b> function. Whether the load inertia ratio or total weight (P1.037) is correctly set affects the speed loop bandwidth of the servo drive.
One Touch Tuning	You must use the <b>One Touch Tuning</b> function with ASDA-Soft. During the tuning process, the motor slightly moves and makes high-frequency noise. For the detailed operation procedure, refer to Section 5.3.
Auto tuning	You can use the <b>Auto Tuning</b> function with ASDA-Soft or through the panel. The command source can be the servo drive or the controller. During the tuning process, the drive controls the motor to run back-and-forth between the two positioning points. For the detailed operation procedure, refer to Section 5.4.
Gain adjustment	The servo provides five gain adjustment modes (not including Manual mode and Gain adjustment mode 4 (Reset to the default gain values)), which is set with P2.032. For the detailed operation procedure and parameter adjustment, refer to Section 5.5.
Manual adjustment	In Manual mode (P2.032 = 0), users can fine-tune all the gain parameters for optimal performance of the machine. For the detailed parameter adjustment, refer to Sections 5.6 and 5.7.

## 5.2 Inertia (Weight) estimation

Whether the load inertia ratio or total weight (P1.037) is correctly set affects the speed loop bandwidth of the servo drive. If set incorrectly, the system's performance cannot be optimized after tuning.

When you use the functions of **One Touch Tuning**, **Auto Tuning**, or Gain adjustment mode 1 (Level adjustment - Auto) with ASDA-Soft, the servo drive automatically estimates the load inertia or weight during the tuning process. If not using the preceding functions, you can directly use the **Inertia (Weight) Estimation** function.

The estimation of load inertia or weight can be done without the controller's command. During the estimation process, the motor runs back-and-forth in the forward and reverse directions. If the estimation cannot be done or the inertia (weight) cannot be correctly estimated in the system, perform the estimation by yourself and set P1.037 with the estimated value.

### 5.2.1 Precautions for inertia (weight) estimation

#### 5.2.1.1 Rotary motor

##### Recommended settings for inertia estimation

1. Jog speed: 500 rpm or above.
2. Acceleration time from 0 rpm to 3,000 rpm or deceleration time from 3,000 rpm to 0 rpm: within 200 ms.
3. Traveling distance: 1 revolution or above.

Description: if the estimated load inertia cannot be reduced to a stable value, increase the jog speed first. If the traveling distance is too long, the estimation time is longer, too.

##### Inertia estimation cannot be done in the following systems

1. The mechanical part only moves in a single direction.
2. The movement speed of the mechanical part is lower than 200 rpm.
3. The effective stroke of the mechanical part is shorter than the traveling distance when the motor rotates 0.5 revolution.

##### Inertia cannot be correctly estimated in the following systems

1. The load inertia ratio of the mechanical part changes drastically.
2. The load inertia ratio of the mechanical part is greater than 50 times.
3. The bandwidth of the mechanical part is lower than 10 Hz.
4. The viscous friction of the mechanical part is high.
5. The torque limit of the mechanical part is too low.

## 5

**5.2.1.2 Linear motor****Recommended settings for weight estimation**

1. Jog speed: 200 mm/s or above.
2. Acceleration time from 0 mm/s to 5,000 mm/s or deceleration time from 5,000 mm/s to 0 mm/s: within 200 ms.
3. Traveling distance: 50 mm or above.

Description: if the estimated weight cannot be reduced to a stable value, increase the jog speed first. If the traveling distance is too long, the estimation time is longer, too.

**Weight estimation cannot be done in the following systems**

1. The mechanical part only moves in a single direction.
2. The movement speed of the mechanical part is lower than 100 mm.
3. The effective stroke of the mechanical part is shorter than the distance when the motor moves 50 mm.

**Weight cannot be correctly estimated in the following systems**

1. The weight of the mechanical part changes drastically.
2. The weight of the mechanical part is greater than 200 kg.
3. The bandwidth of the mechanical part is lower than 10 Hz.
4. The viscous friction of the mechanical part is high.
5. The torque limit of the mechanical part is too low.

## 5.2.2 Inertia (Weight) estimation with ASDA-Soft

Go to [Delta's website](#) to download ASDA-Soft for free to tune the servo drive. After installing ASDA-Soft, start the executable file and the screen is as follows.

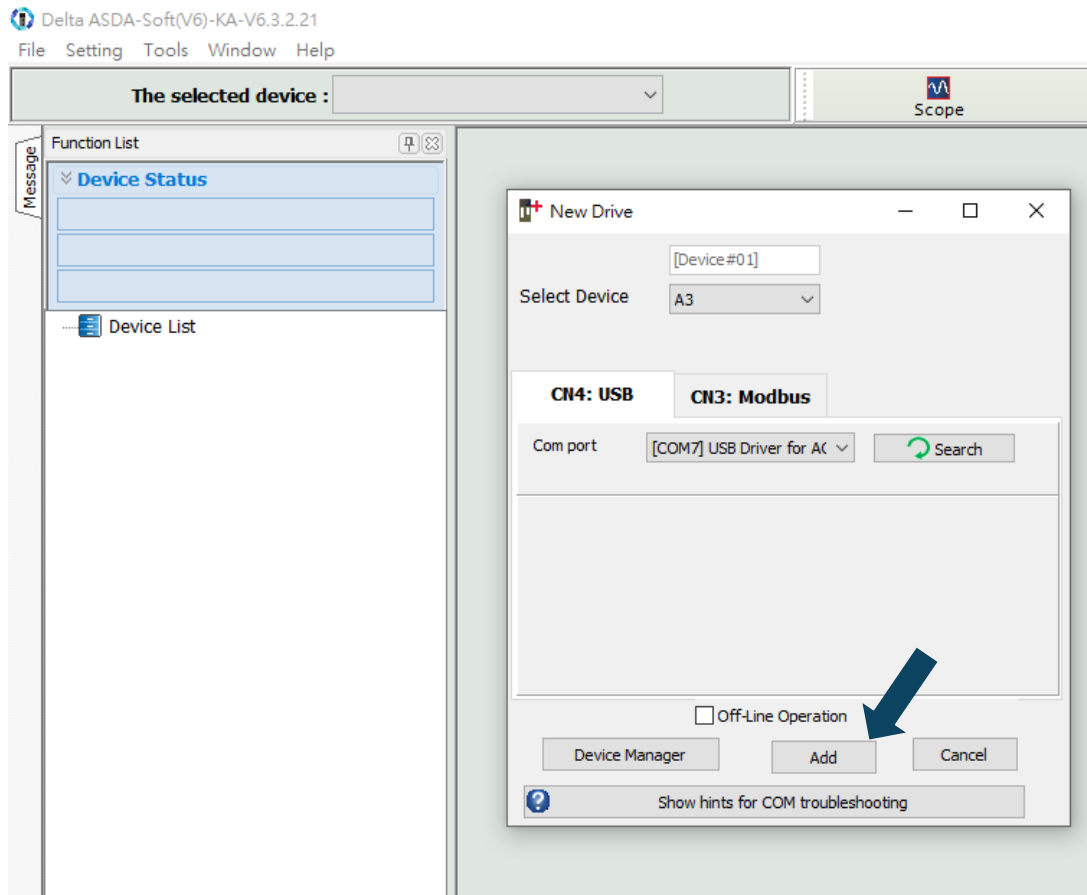

Make sure your servo drive, servo motor, and power are all properly connected. Click **Search**, and the software automatically selects the corresponding communication port (USB Driver for Delta AC Servo Drive). Then, click **Add** for the ASDA-Soft to be in online mode.



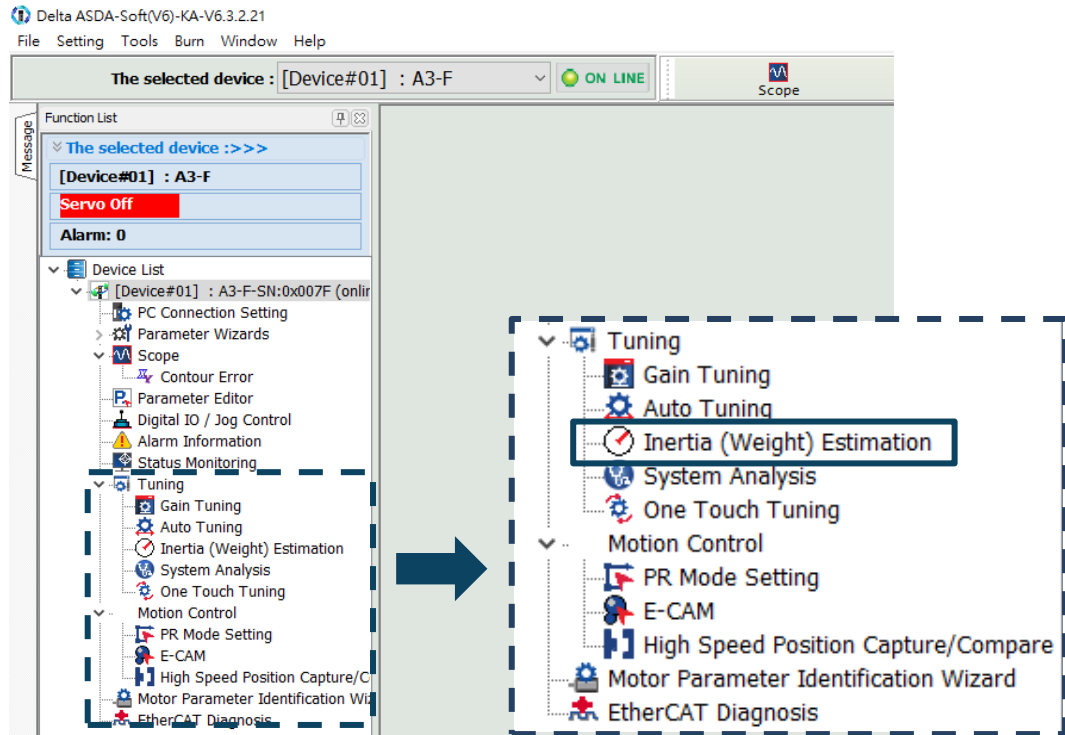

When ASDA-Soft is in online mode, the program window appears as follows. Click **Inertia (Weight) Estimation** in the Function List tree view.

5

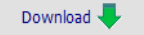

### 5.2.2.1 Rotary motor

Perform the inertia estimation according to the following descriptions.

1. Set the system to the Servo ON state.
2. The default jog speed is 20 rpm and the default acceleration / deceleration time is 200 ms. For mechanical parts with limited strokes, low speed movement reduces the risk of collision. Executing positioning between two points at low speed is recommended. For mechanical parts with longer strokes or without limits, you can set the movement speed higher. After completing the settings, click the  button, and then use the Left () or Right () button to rotate the motor to Position 1 and Position 2.
3. Check the acceleration / deceleration time and jog speed again. It is advisable to set the jog speed to no less than 500 rpm. Then click the  button. After the download is complete, click **Start Moving**, and the motor regards Position 1 and Position 2 as the positive and negative limits and starts rotating in the forward and reverse directions.
4. After the estimation is complete, click **Stop Moving** and then **Download** to download the estimated load inertia ratio to the servo drive.
5. Since the new inertia ratio causes a change in the equivalent bandwidth, resonance may occur in the system. Thus, you need to use the **Gain Tuning** function to set the bandwidth and gain again when writing the new inertia ratio to the system.

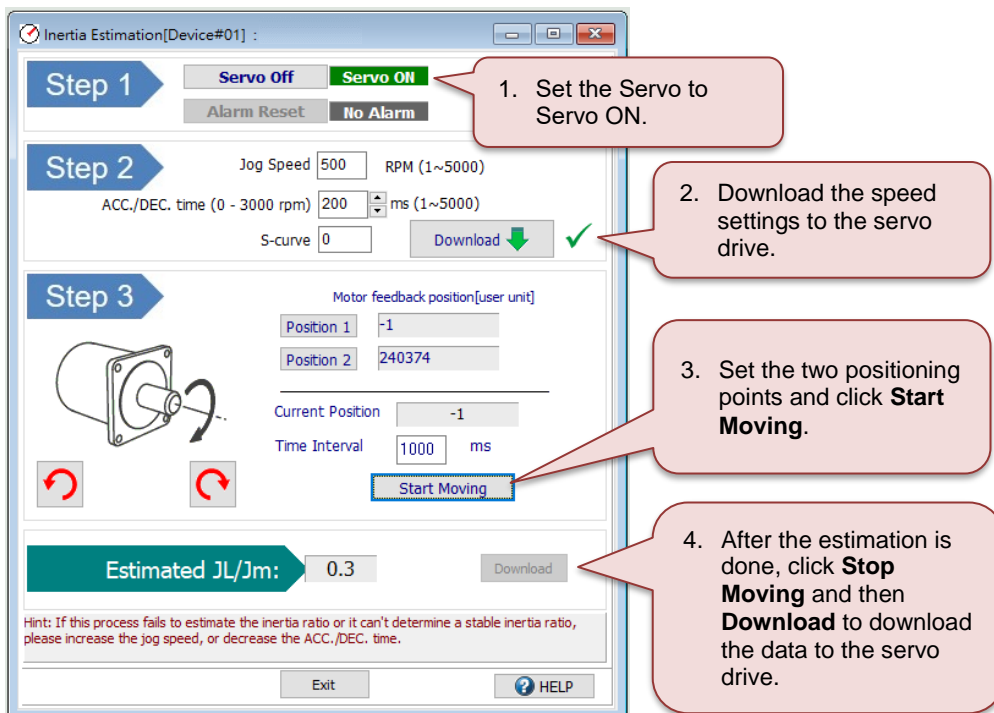

The screenshot shows the 'Inertia Estimation[Device#01]' window. It is divided into three steps:

- Step 1:** Servo status is set to 'Servo ON'. Callout: '1. Set the Servo to Servo ON.'
- Step 2:** Jog Speed is 500 RPM, ACC./DEC. time is 200 ms. A 'Download' button with a green checkmark is visible. Callout: '2. Download the speed settings to the servo drive.'
- Step 3:** Motor feedback position is set. Position 1 is -1 and Position 2 is 240374. The 'Start Moving' button is highlighted. Callout: '3. Set the two positioning points and click **Start Moving**.'



At the bottom, the 'Estimated J<sub>L</sub>/J<sub>m</sub>' is shown as 0.3, with a 'Download' button next to it. Callout: '4. After the estimation is done, click **Stop Moving** and then **Download** to download the data to the servo drive.'

Hint: If this process fails to estimate the inertia ratio or it can't determine a stable inertia ratio, please increase the jog speed, or decrease the ACC./DEC. time.

## 5

## 5.2.2.2 Linear motor

Perform the weight estimation according to the following descriptions.

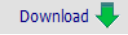
1. Set the system to the Servo ON state.
2. The default jog speed is 50 mm/s and the default acceleration / deceleration time is 200 ms. For mechanical parts with limited strokes, low speed movement reduces the risk of collision. Executing positioning between two points at low speed is recommended. For mechanical parts with longer strokes or without limits, you can set the movement speed higher. After completing the settings, click the  button, and then use the Left () or Right () button to move the motor to Position 1 and Position 2.
3. Check the acceleration / deceleration time and jog speed again. It is advisable to set the jog speed to no less than 200 mm/s. Then click the  button. After the download is complete, click **Start Moving**, and the motor regards Position 1 and Position 2 as the positive and negative limits and starts moving in the left and right directions.
4. After the estimation is complete, click **Stop Moving** and then **Download** to download the estimated weight to the servo drive.
5. Since the new weight causes a change in the equivalent bandwidth, resonance may occur in the system. Thus, you need to use the **Gain Tuning** function to set the bandwidth and gain again when writing the new weight to the system.

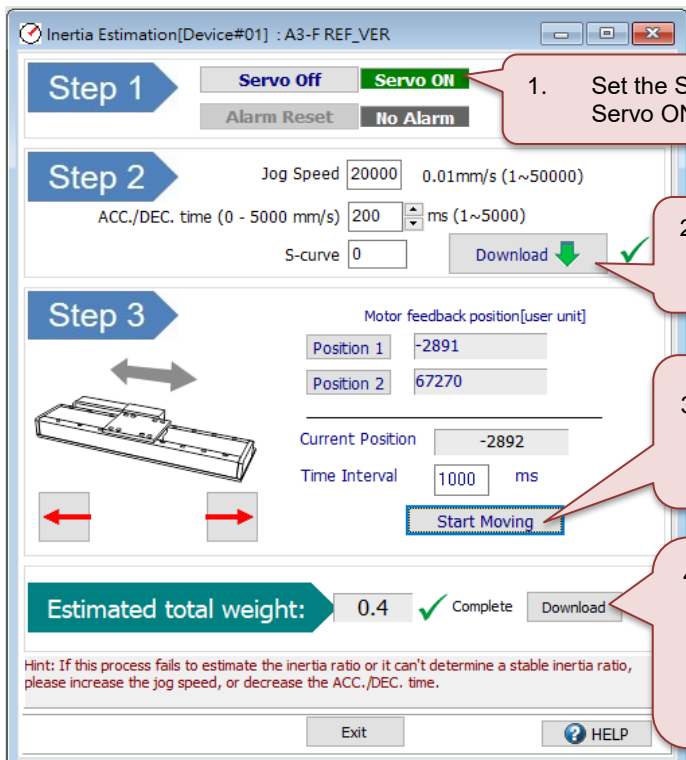

The screenshot shows the 'Inertia Estimation' software interface. It is divided into three steps:

- Step 1:** Shows 'Servo Off' and 'Servo ON' buttons. A callout points to the 'Servo ON' button with the instruction: '1. Set the Servo to Servo ON.'
- Step 2:** Shows 'Jog Speed' (20000), 'ACC./DEC. time' (200 ms), and 'S-curve' (0). A 'Download' button with a green arrow and checkmark is highlighted. A callout points to it: '2. Download the speed settings to the servo drive.'
- Step 3:** Shows 'Motor feedback position[user unit]' with 'Position 1' (-2891) and 'Position 2' (67270). A 'Start Moving' button is highlighted. A callout points to it: '3. Set the two positioning points and click **Start Moving**.'

At the bottom, the 'Estimated total weight' is shown as 0.4 with a green checkmark and 'Complete' status. A 'Download' button is also present. A callout points to this area: '4. After the estimation is done, click **Stop Moving** and then **Download** to download the data to the servo drive.'

Hint: If this process fails to estimate the inertia ratio or it can't determine a stable inertia ratio, please increase the jog speed, or decrease the ACC./DEC. time.

### 5.3 One Touch Tuning

You must use the One Touch Tuning function with ASDA-Soft. During the tuning process, the motor slightly moves and makes high-frequency noise. The following table lists the parameters which settings change according to the results of one touch tuning. In One Touch Tuning mode, the vibration elimination function is enabled and the low-frequency vibration suppression function is disabled. If the two functions are enabled simultaneously, the response becomes slower.

Gain parameters			
Parameter No.	Function	Parameter No.	Function
P1.037	Load inertia ratio or total weight	P2.032	Gain adjustment mode
P2.000	Position control gain	P2.089	Command response gain
P2.004	Speed control gain	P2.090	Two degree of freedom mode - anti-interference gain
P2.006	Speed integral compensation	P2.094	Special bit register 3 (enable the two degree of freedom control function)
P2.031	Bandwidth response level	-	-

Filter and resonance suppression parameters			
Parameter No.	Function	Parameter No.	Function
P1.025	Low-frequency vibration suppression frequency 1	P2.044	Notch filter 2 - attenuation level
P1.026	Low-frequency vibration suppression gain 1	P2.045	Notch filter 3 - frequency
P1.027	Low-frequency vibration suppression frequency 2	P2.046	Notch filter 3 - attenuation level
P1.028	Low-frequency vibration suppression gain 2	P2.049	Speed detection filter and jitter suppression
P2.023	Notch filter 1 - frequency	P2.098	Notch filter 4 - frequency
P2.024	Notch filter 1 - attenuation level	P2.099	Notch filter 4 - attenuation level
P2.025	Resonance suppression low-pass filter	P2.101	Notch filter 5 - frequency
P2.043	Notch filter 2 - frequency	P2.102	Notch filter 5 - attenuation level



## 5

### 5.3.1 Precautions for one touch tuning

#### 5.3.1.1 Rotary motor

One touch tuning cannot be done in the following system

1. The mechanical part only moves in a single direction.

One touch tuning cannot be correctly used in the following systems

1. The load inertia ratio of the mechanical part changes drastically.
2. The load inertia ratio of the mechanical part is greater than 100 times.
3. The viscous friction of the mechanical part is high.
4. The torque limit of the mechanical part is too low.
5. The gear backlash in the mechanical part is too large.

#### 5.3.1.2 Linear motor

One touch tuning cannot be done in the following system

1. The mechanical part only moves in a single direction.

One touch tuning cannot be correctly used in the following systems

1. The weight of the mechanical part changes drastically.
2. The weight of the mechanical part is greater than 200 kg.
3. The viscous friction of the mechanical part is high.
4. The torque limit of the mechanical part is too low.
5. The gear backlash in the mechanical part is too large.

### 5.3.2 One touch tuning with ASDA-Soft

Go to [Delta's website](#) to download ASDA-Soft for free to tune the servo drive. After installing ASDA-Soft, start the executable file and the screen is as follows.

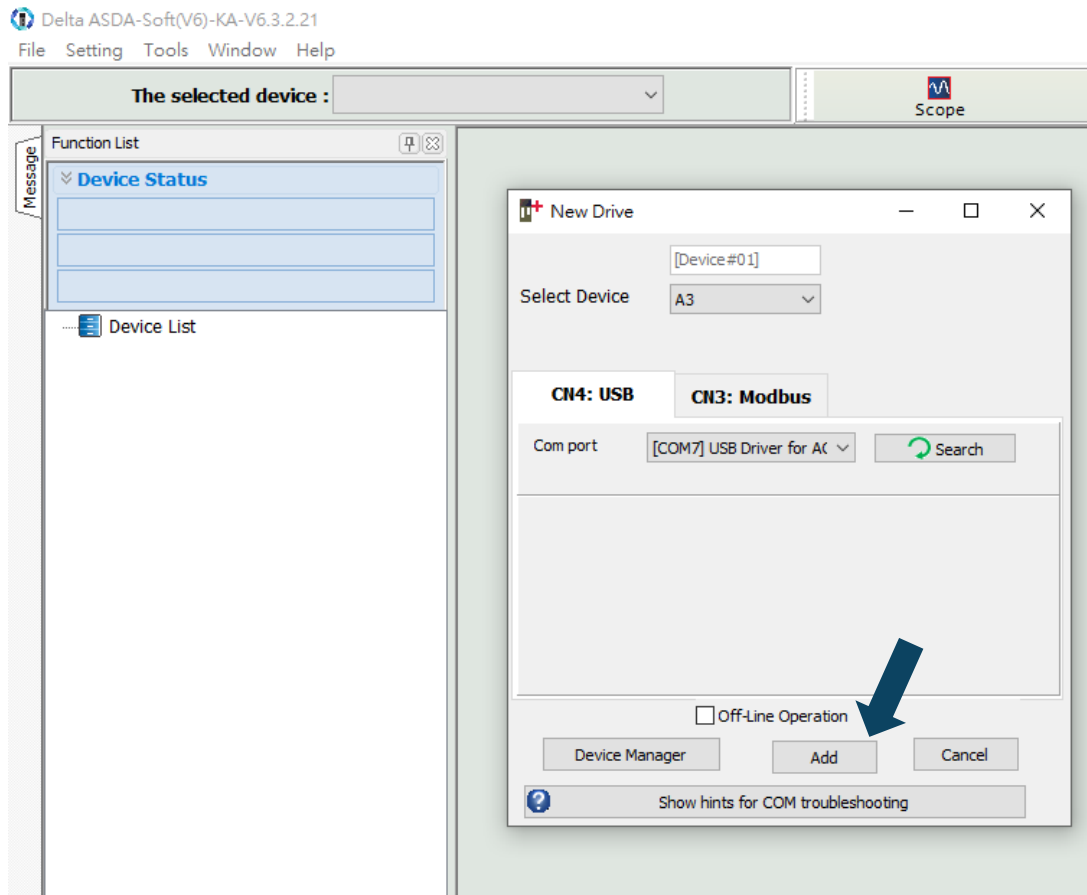

Make sure your servo drive, servo motor, and power are all properly connected. Click **Search**, and the software automatically selects the corresponding communication port (USB Driver for Delta AC Servo Drive). Then, click **Add** for the ASDA-Soft to be in online mode.

When ASDA-Soft is in online mode, the program window appears as follows. Click **One Touch Tuning** in the Function List tree view.

5

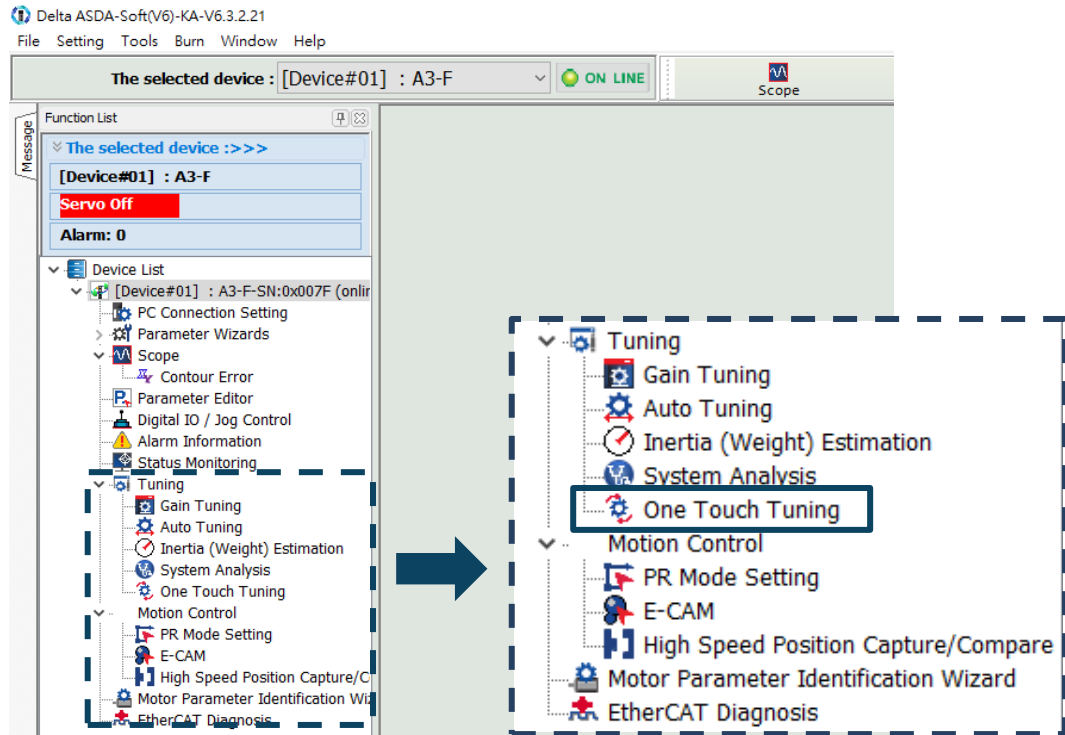

Click **Start**.

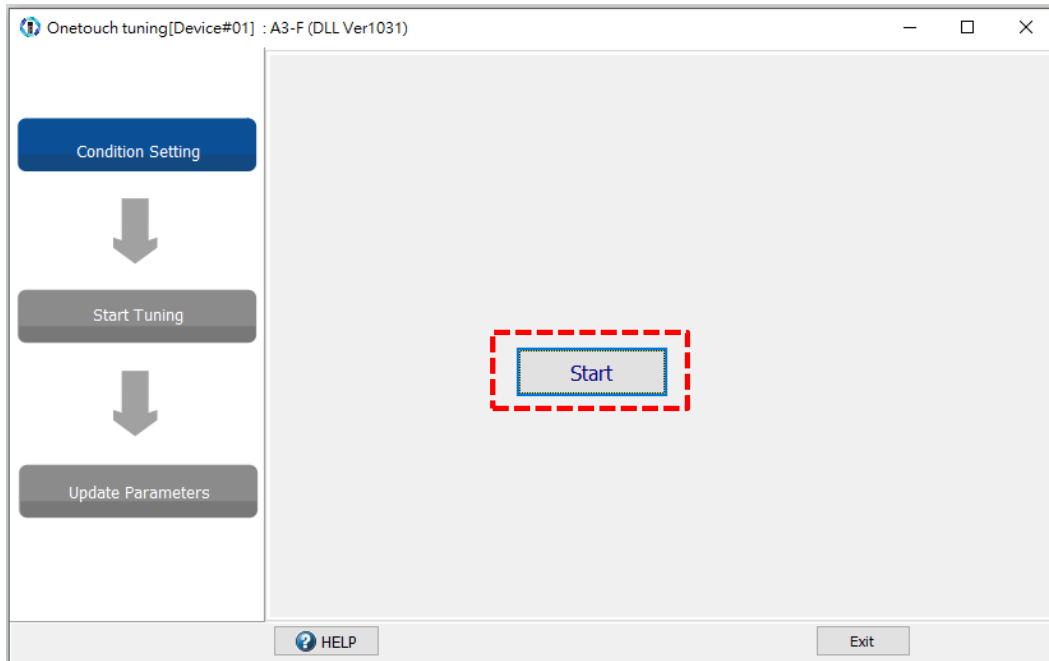

Carefully read the content in the warning window and make sure you have checked all the items one by one. Select the check box for **I have read the warning above** and click **Yes**.

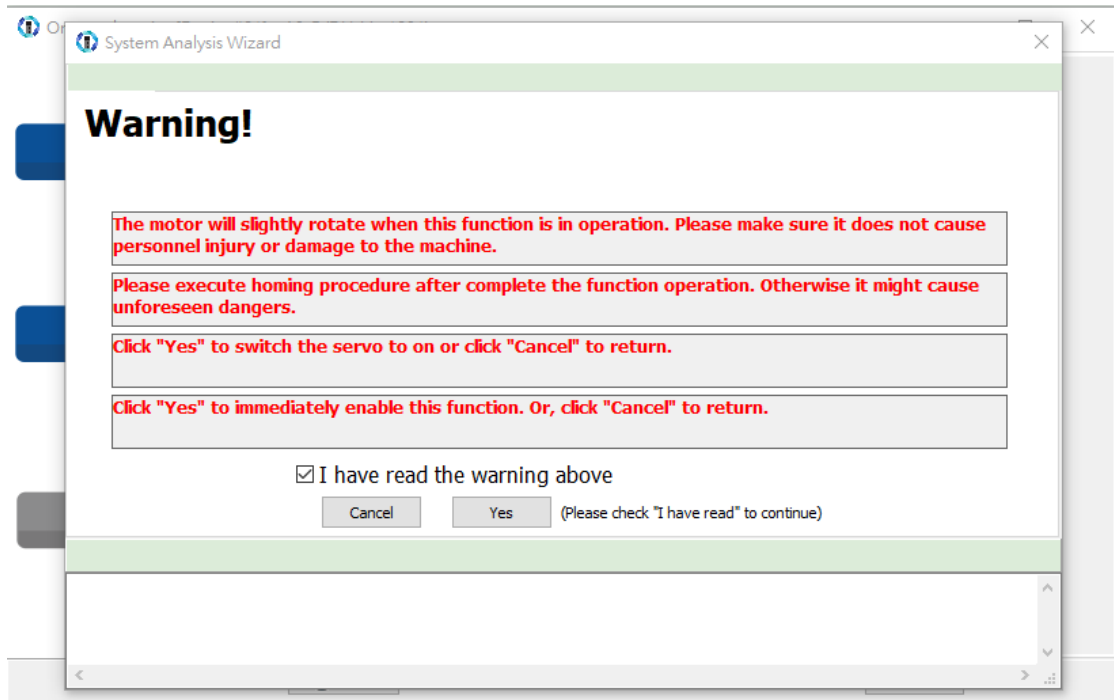

The screen shows a table comparing the parameter values before and after tuning. In the screen, you can fine-tune the gain level, and the adjustments affect the settings of other relevant parameters.

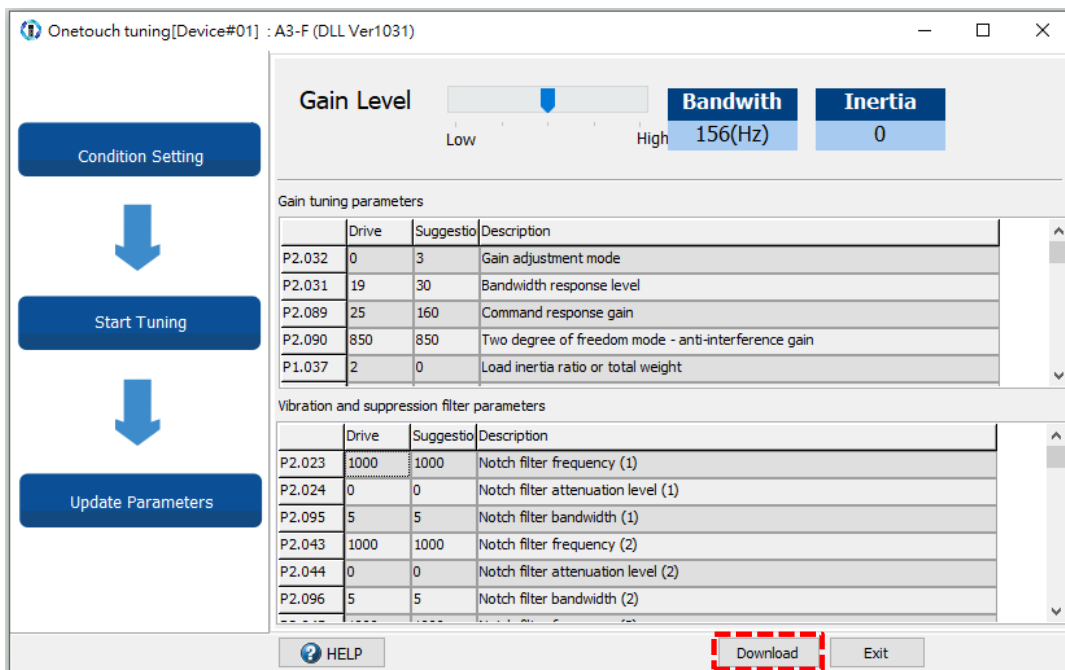

Click **Download** to complete one touch tuning.

Note: if you click **Exit** without clicking **Download** first, the suggested values estimated by the one touch function are not loaded to the servo drive.

## 5

## 5.4 Auto tuning

The auto tuning function enables the system to perform real-time estimation for machine inertia or machine weight and uploads the optimized parameters to the servo drive. You can start auto tuning with ASDA-Soft (software) or through the drive panel. The following table lists the parameters that change according to the results of auto tuning.

Gain parameters			
Parameter No.	Function	Parameter No.	Function
P1.037	Load inertia ratio or total weight	P2.031	Bandwidth response level
P2.000	Position control gain	P2.032	Gain adjustment mode
P2.002	Position feed forward gain	P2.089	Command response gain
P2.004	Speed control gain	P2.090	Two degree of freedom mode - anti-interference gain
P2.006	Speed integral compensation	P2.094	Special bit register 3 (enable the two degree of freedom control function)
P2.026	Anti-interference gain	-	-

Filter and resonance suppression parameters			
Parameter No.	Function	Parameter No.	Function
P1.025	Low-frequency vibration suppression frequency 1	P2.025	Resonance suppression low-pass filter
P1.026	Low-frequency vibration suppression gain 1	P2.043	Notch filter 2 - frequency
P1.027	Low-frequency vibration suppression frequency 2	P2.044	Notch filter 2 - attenuation level
P1.028	Low-frequency vibration suppression gain 2	P2.045	Notch filter 3 - frequency
P1.029	Auto low-frequency vibration suppression mode	P2.046	Notch filter 3 - attenuation level
P1.061	Viscous friction compensation	P2.049	Speed detection filter and jitter suppression
P1.062	Percentage of friction compensation	P2.095	Notch filter 1 - Q factor
P1.063	Constant of friction compensation	P2.096	Notch filter 2 - Q factor
P1.089	Vibration elimination 1 - anti-resonance frequency	P2.097	Notch filter 3 - Q factor
P1.090	Vibration elimination 1 - resonance frequency	P2.098	Notch filter 4 - frequency
P1.091	Vibration elimination 1 - resonance difference	P2.099	Notch filter 4 - attenuation level
P1.092	Vibration elimination 2 - anti-resonance frequency	P2.100	Notch filter 4 - Q factor
P1.093	Vibration elimination 2 - resonance frequency	P2.101	Notch filter 5 - frequency
P1.094	Vibration elimination 2 - resonance difference	P2.102	Notch filter 5 - attenuation level
P2.023	Notch filter 1 - frequency	P2.103	Notch filter 5 - Q factor
P2.024	Notch filter 1 - attenuation level	-	-

## 5.4.1 Precautions for auto tuning

### 5.4.1.1 Rotary motor

#### Recommended settings for auto tuning

1. Jog speed: 500 rpm or above.
2. Acceleration time from 0 rpm to 3,000 rpm or deceleration time from 3,000 rpm to 0 rpm: within 200 ms.
3. Traveling distance: 1 revolution or above.

Description: it is advisable to set the minimum distance for the motor to accelerate from zero speed to the constant speed zone as the traveling distance, and the constant speed is equal to the set jog speed. If the traveling distance is too long, the estimation time is longer, too. For mechanical parts with long strokes, it is recommended that you set the traveling distance as the working range for operation.

#### Auto tuning cannot be done in the following systems

1. The mechanical part only moves in a single direction.
2. The movement speed of the mechanical part is lower than 200 rpm.
3. The effective stroke of the mechanical part is shorter than the traveling distance when the motor rotates 0.5 revolution.

#### Auto tuning cannot be correctly done in the following systems

1. The load inertia ratio of the mechanical part changes drastically.
2. The load inertia ratio of the mechanical part is greater than 50 times.
3. The bandwidth of the mechanical part is lower than 10 Hz.
4. The viscous friction of the mechanical part is high.
5. The torque limit of the mechanical part is too low.

## 5

**5.4.1.2 Linear motor****Recommended settings for auto tuning**

1. Jog speed: 200 mm/s or above.
2. Acceleration time from 0 mm/s to 5,000 mm/s or deceleration time from 5,000 mm/s to 0 mm/s: within 200 ms.
3. Traveling distance: 50 mm or above.

Description: if the estimated weight cannot be reduced to a stable value, increase the jog speed first. If the traveling distance is too long, the estimation time is longer, too.

**Auto tuning cannot be done in the following systems**

1. The mechanical part only moves in a single direction.
2. The movement speed of the mechanical part is lower than 100 mm.
3. The effective stroke of the mechanical part is shorter than the distance when the motor moves 50 mm.

**Auto tuning cannot be correctly done in the following systems**

1. The weight of the mechanical part changes drastically.
2. The weight of the mechanical part is greater than 200 kg.
3. The bandwidth of the mechanical part is lower than 10 Hz.
4. The viscous friction of the mechanical part is high.
5. The torque limit of the mechanical part is too low.

### 5.4.2 Flowchart of auto tuning

You can complete auto tuning through the drive panel or with ASDA-Soft. The Auto Tuning function helps you to find the most suitable parameters for your system according to the machine characteristics.

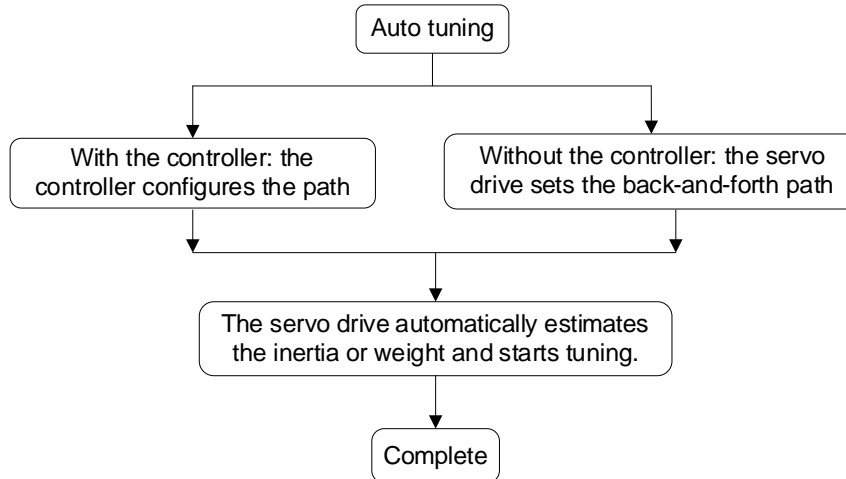

Note: when the path is configured by the controller, make sure the delay time is added to the operation cycle. Otherwise, AL08B occurs and the servo drive cannot complete auto tuning.

You can use P2.105 and P2.106 to adjust the stiffness and response in Auto Tuning mode. See the following flowchart.

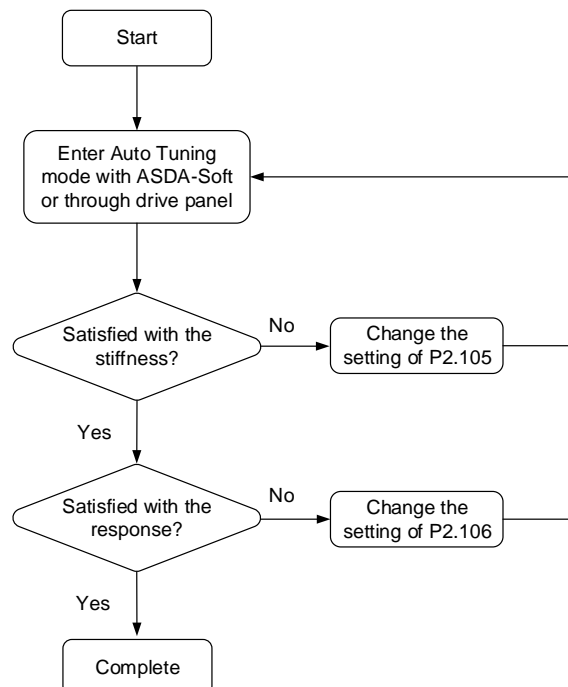



# 5

## 5.4.3 Auto tuning through the drive panel

You can use the drive panel to start auto tuning. Make sure the emergency stop and positive and negative limit switches work properly before you start to tune the system.

### 5.4.3.1 Rotary motor

Flowchart of auto tuning

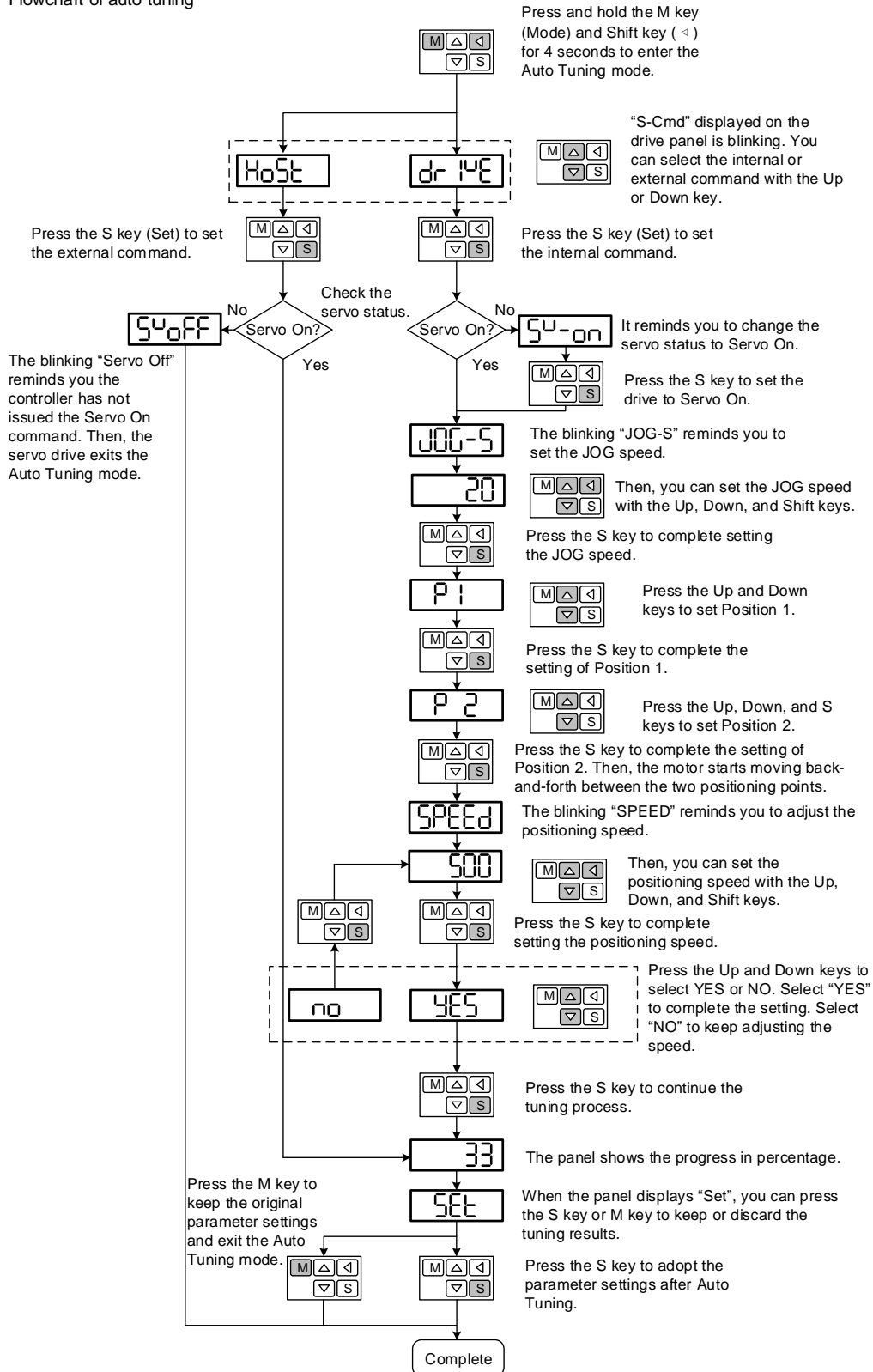

5.4.3.2 Linear motor

Flowchart of auto tuning

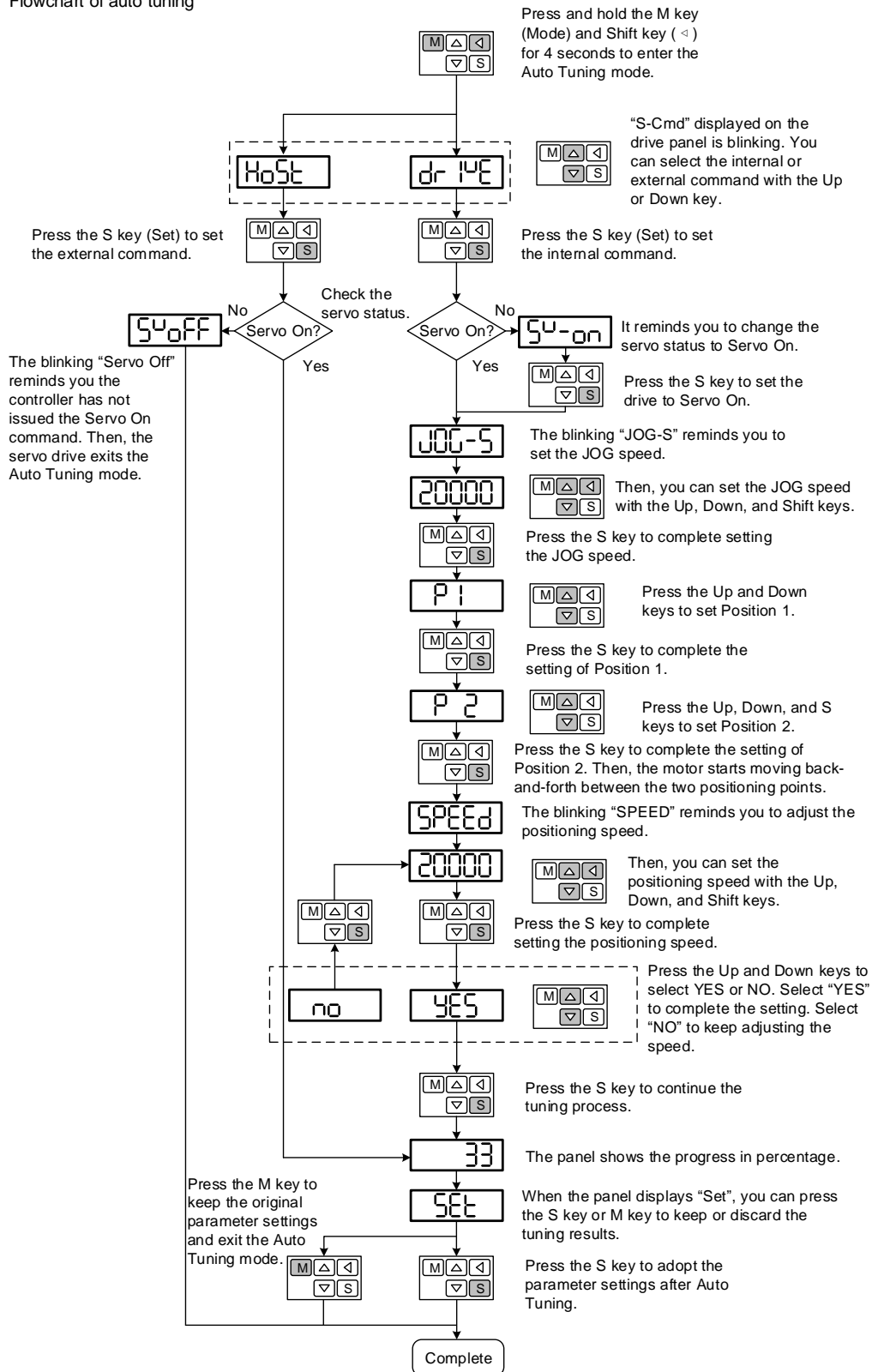

## 5

### 5.4.4 Auto tuning with ASDA-Soft

In addition to executing auto tuning through the drive panel, you can go to [Delta's website](#) to download ASDA-Soft for free to tune the servo drive. After installing ASDA-Soft, start the executable file and the screen is as follows.

Note: this section only provides descriptions for rotary motors. Refer to Section 5.4.1.2 for linear motor descriptions.

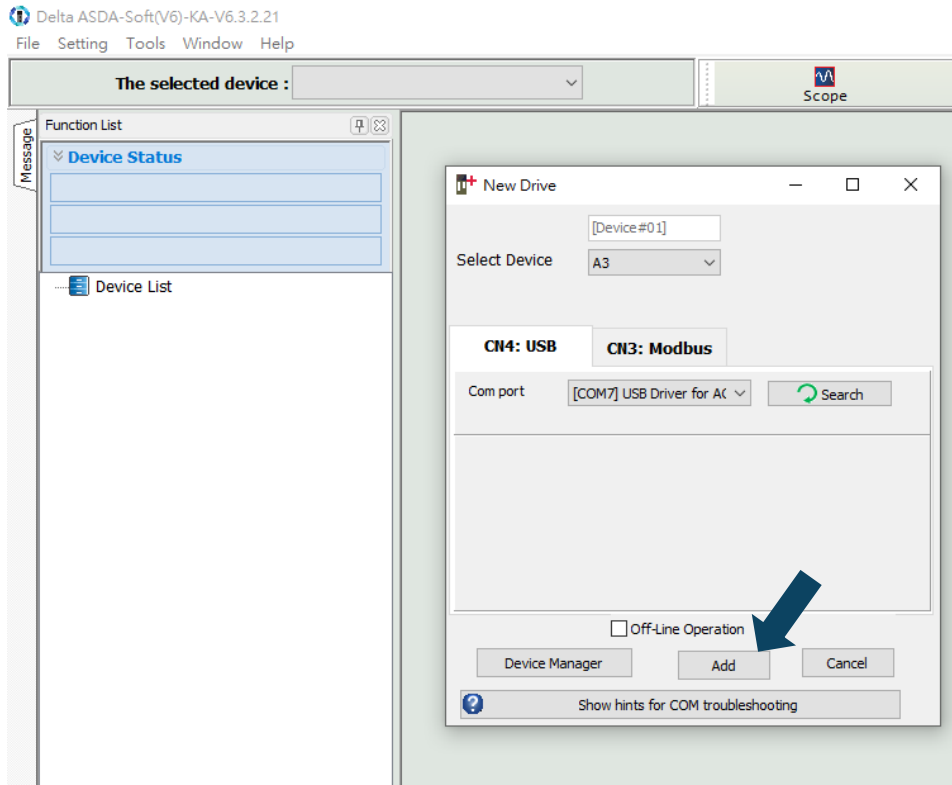

Make sure your servo drive, servo motor, and power are all properly connected. Then click **Add** for the ASDA-Soft to be in online mode.

When ASDA-Soft is in online mode, start auto tuning according to the following steps. The following describes two auto tuning procedures, one using the controller and the other using the servo drive.

- Auto-tuning with the controller: the controller sends the commands to drive the motor.

Step 1:

When ASDA-Soft is in online mode, the program window appears as follows. Click **Auto Tuning** in the Function List tree view.

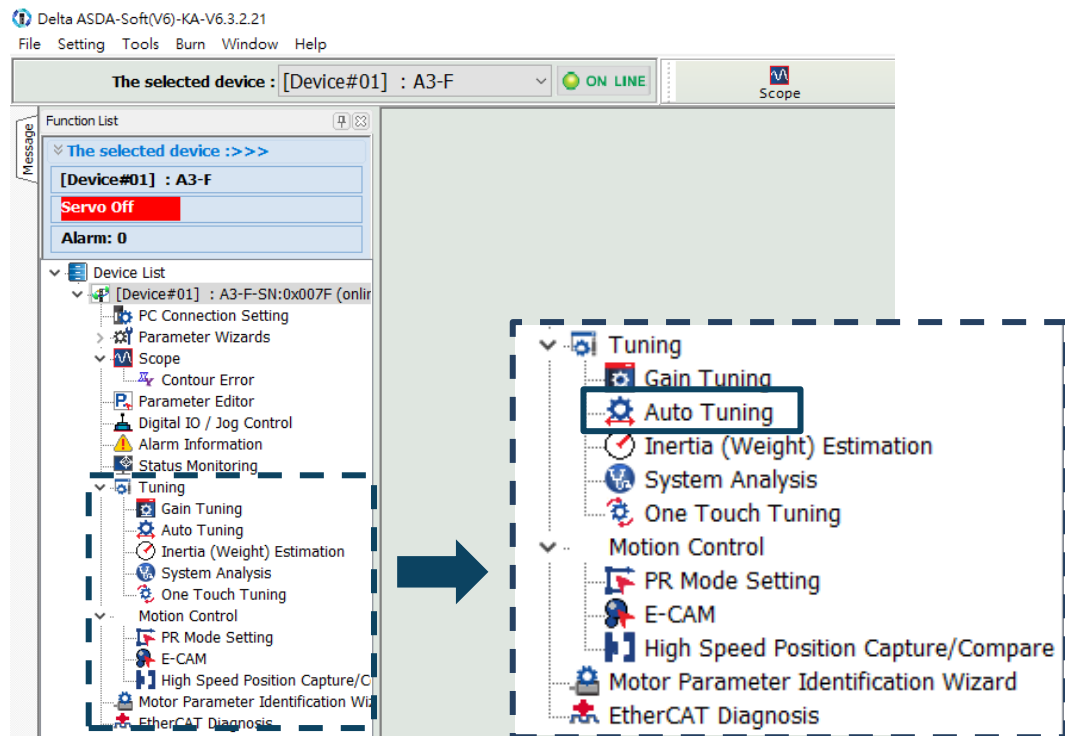

5

Step 2:

Click **Controller: Motion Command from Controller** and check for the motion / machining path.

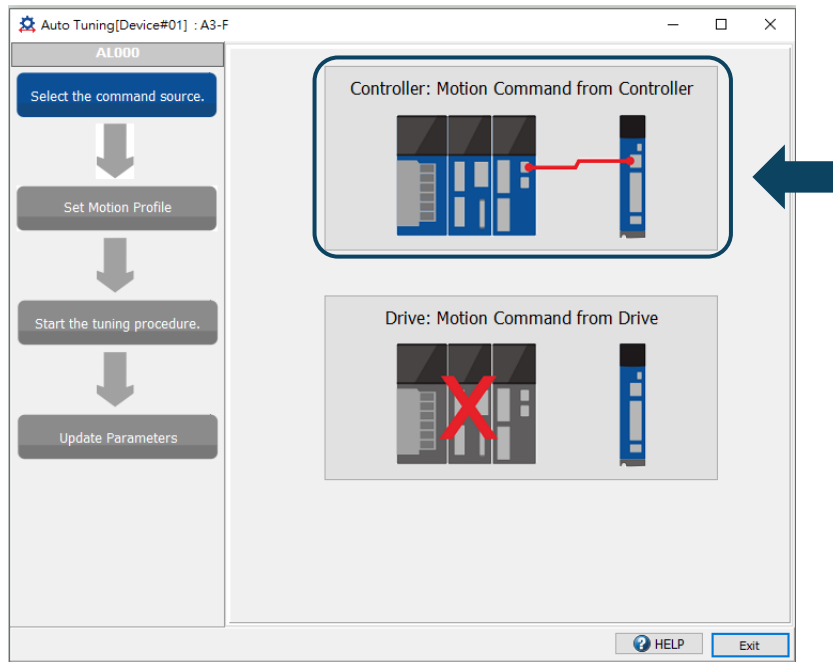

Suggestions: set the motor to operate at least one cycle in both forward and reverse directions. The delay time for reaching the positioning points in both forward and reverse directions should be no less than 1000 ms with the running speed no less than 500 rpm.

Step 3:

Repeatedly run the motor with the path you just set. Make sure no personnel is standing close to the machinery, and then you can click **Next** to start the auto tuning procedure.

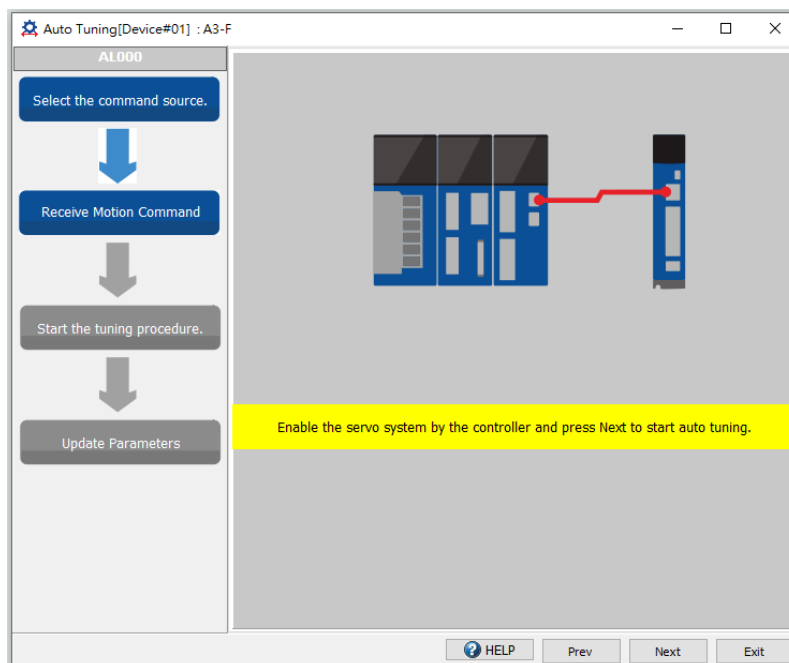

Wait until the tuning progress bar reaches 100%, and a window with “Auto tuning completed.” appears as follows. Then click **OK**.

5

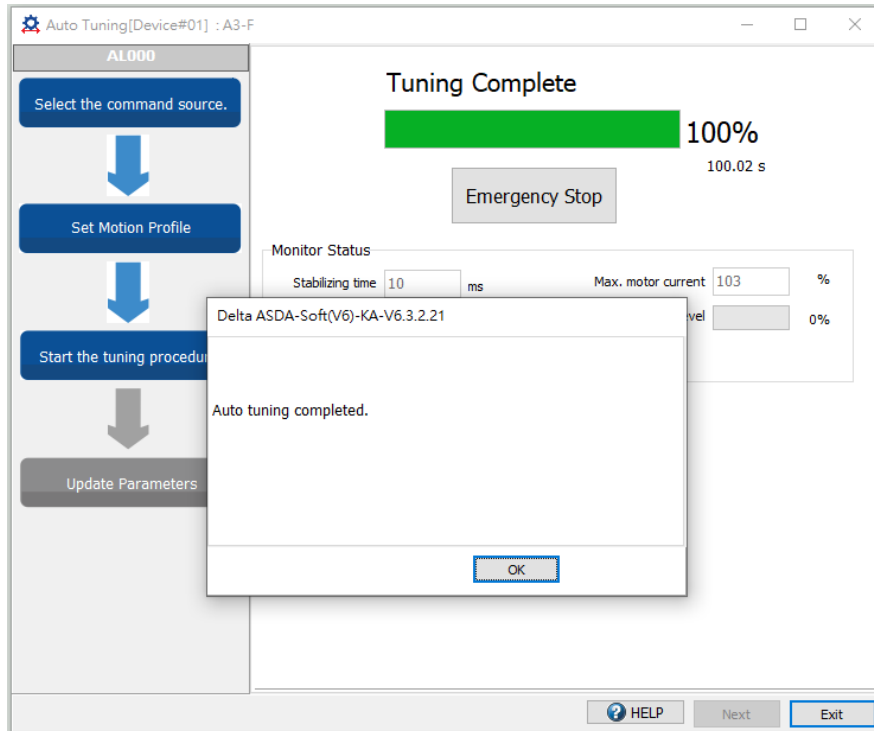

The screen shows a table comparing the parameter values before and after tuning.

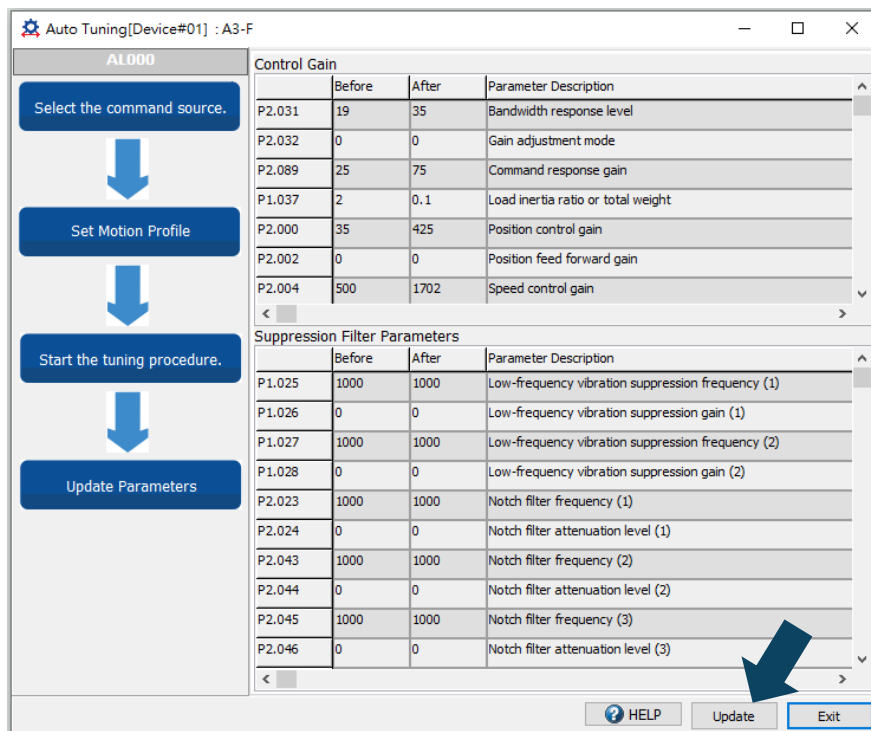

Click **Update** to complete auto tuning.

5

- Auto-tuning with the servo drive: the servo drive sends the commands to drive the motor.

Step 1:

When ASDA-Soft is in online mode, the program window appears as follows. Click **Auto Tuning** in the Function List tree view.

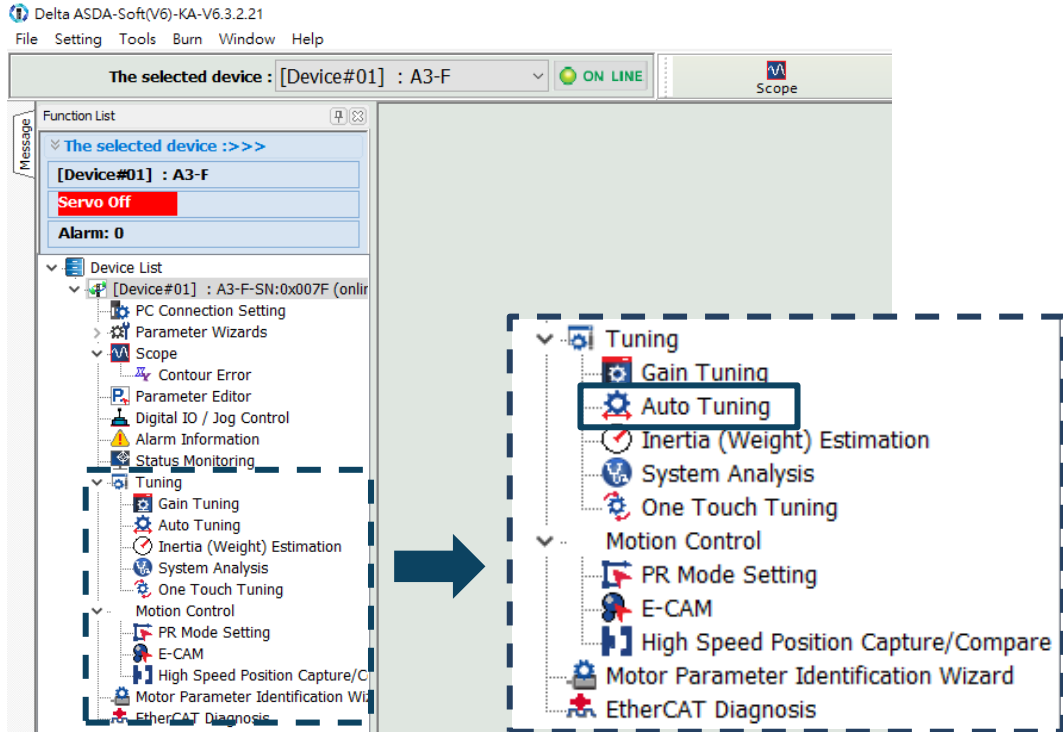

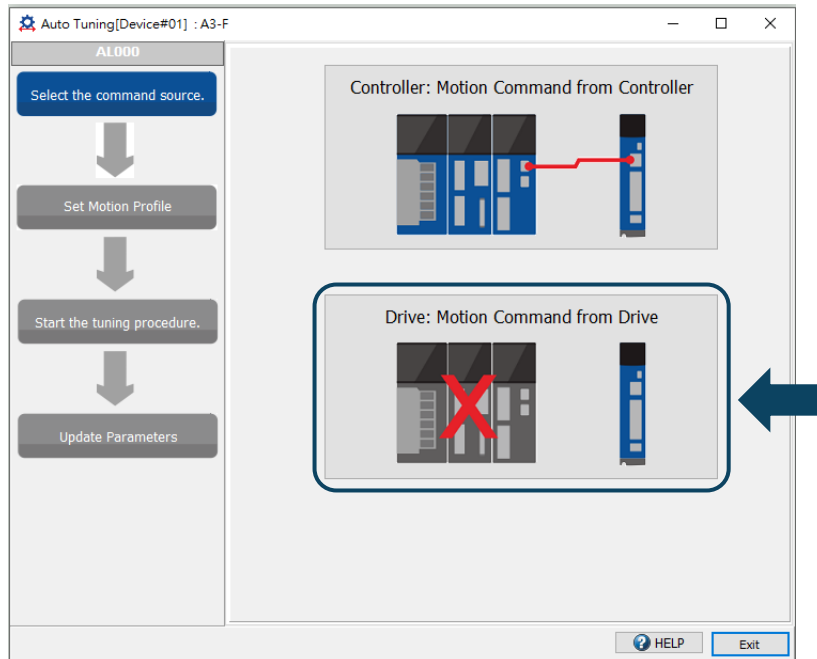

Step 2:

Click **Drive: Motion Command from Drive** to enter the setting screen of motion profile.

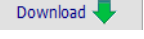

Follow these steps to set the motor running path:

- Set P2.105 and P2.106 based on the application condition. Refer to Section 5.4.5 for details.
  - P2.105: the higher the setting value, the higher the bandwidth after auto tuning, which is applicable to devices with high stiffness or high response. On the other hand, the lower the setting value, the lower the bandwidth after auto tuning, which is applicable to devices with complex structure or low stiffness.
  - P2.106: the lower the setting value, the smaller the overshoot after auto tuning. But if the setting value is too low, the settling time may be too long.
- Set the system to the Servo ON state.
- The default jog speed is 20 rpm and the default acceleration / deceleration time is 200 ms. For mechanical parts with limited strokes, low speed movement reduces the risk of collision. Executing positioning with two points at low speed is recommended. For mechanical parts with longer strokes or without limits, you can set the movement speed higher. After completing the settings, click the  button, and then use the Left () or Right () button to rotate the motor to Position 1 and Position 2.
- Check the acceleration / deceleration time and jog speed again. It is advisable to set the jog speed to no less than 500 rpm. Then click the  button. After the download is complete, click **Start Moving**, and the motor regards Position 1 and Position 2 as the positive and negative limits and starts rotating in the forward and reverse directions.
- After completing the settings, make sure no personnel is standing close to the machinery. Then, click **Next**.
- If the tuning results do not meet the requirements, modify the setting values of P2.105 and P2.106, or refer to Section 5.6 to manually adjust certain parameters and then perform the auto tuning again.

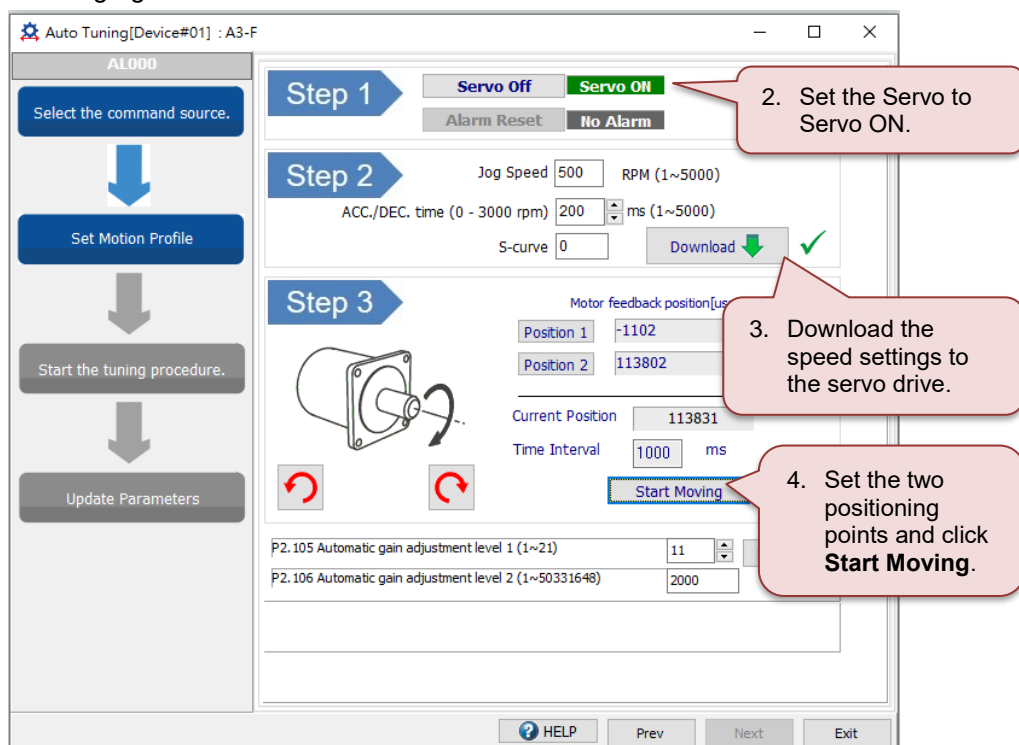



5

Step 3:

Wait until the tuning progress bar reaches 100%, and a window with “Auto tuning completed.” appears as follows. Then click **OK**.

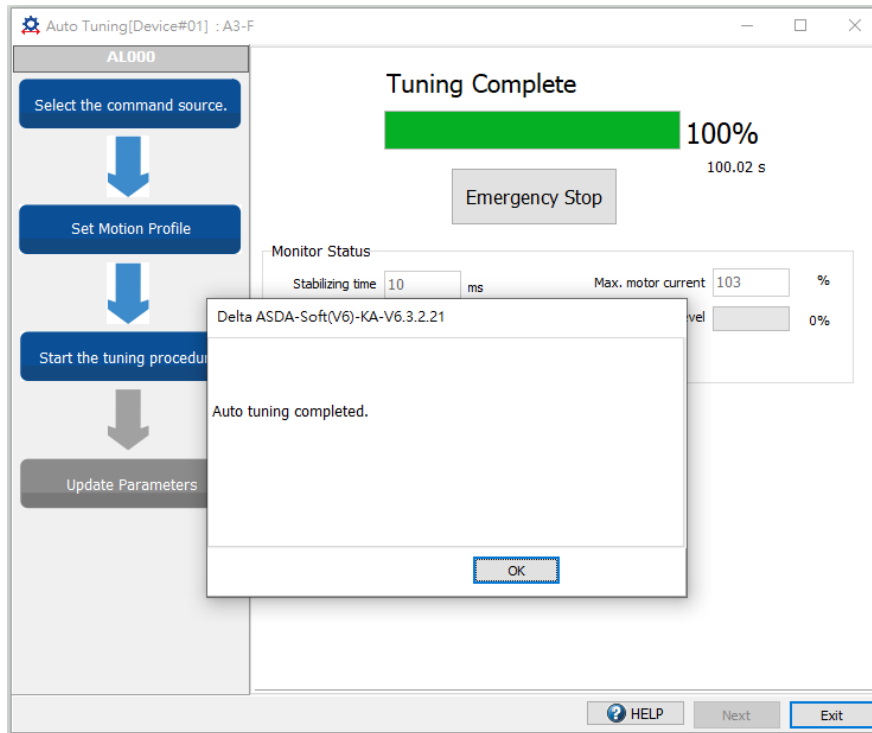

The screen shows a table comparing the parameter values before and after tuning.

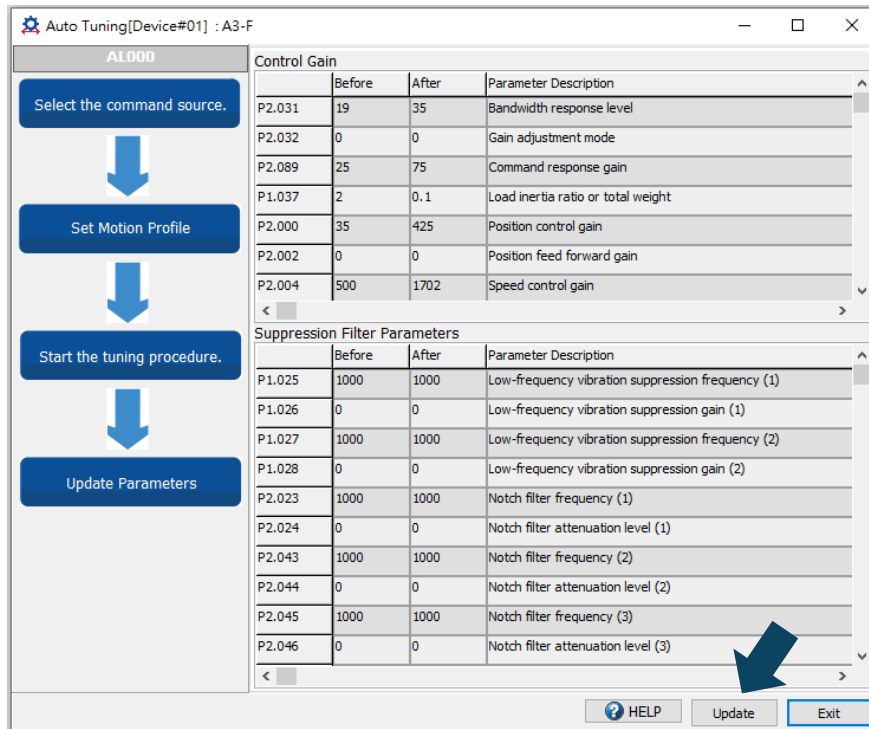

Click **Update** to complete auto tuning.

## 5.4.5 Parameters related to auto tuning

Before the auto gain adjustment starts, first set the automatic gain adjustment level 1 (P2.105) and automatic gain adjustment level 2 (P2.106), which are only available for **Auto Tuning**.

5

### 5.4.5.1 Automatic gain adjustment level 1 (P2.105) - stiffness adjustment

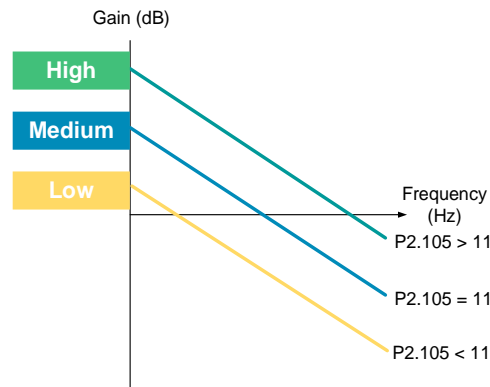

P2.105 defines the servo stiffness after auto tuning. The higher the setting value, the greater the bandwidth after auto tuning. On the other hand, the system margin becomes smaller, which means resonance is more likely to occur when the system is degrading. You can first set P2.105 to the default value of 11 and then change the setting according to the following conditions.

1. It is advisable to increase P2.105 if the machine has all the following characteristics.
  - The load inertia (weight) changes slightly during machine operation.
  - Connected to transmission components with high stiffness (for example, they are direct-coupled or connected with couplings).
  - The machine requires high responsiveness.
2. It is advisable to decrease P2.105 if the machine has one of the following characteristics.
  - The load inertia (weight) changes constantly during machine operation (such as transport equipment and robotic arms).
  - The machine has a transmission component with long strokes (such as a lead screw with the length of 3 m or longer or a belt with the length of 1 m or longer).

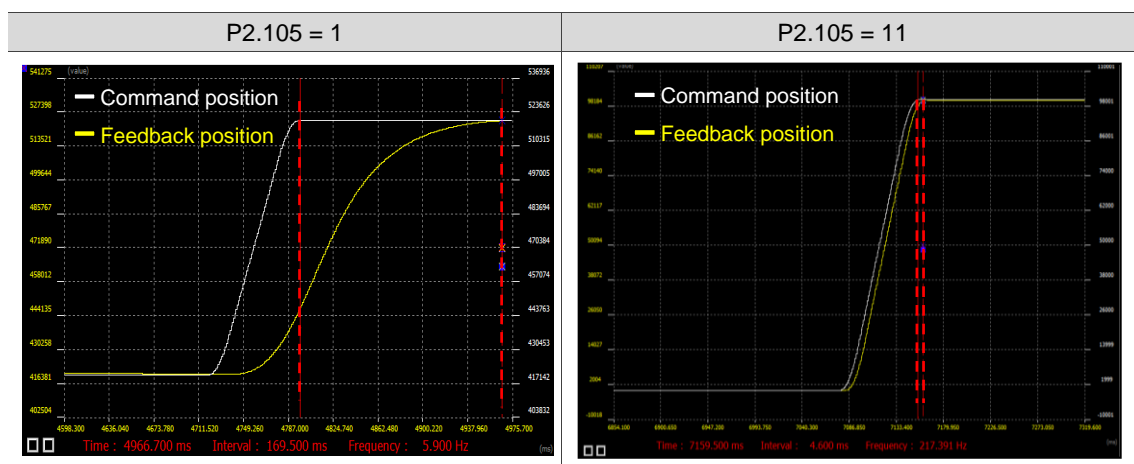

5

5.4.5.2 Automatic gain adjustment level 2 (P2.106) - response adjustment

P2.106 sets the maximum overshoot. A proper setting of the amount of overshoot increases the system response. The higher the setting value, the greater the allowable amount of overshoot. For mechanical parts with higher stiffness, the setting of P2.106 affects the position loop parameters P2.000 and P2.089 instead of the parameters related to speed loop gain and filters.

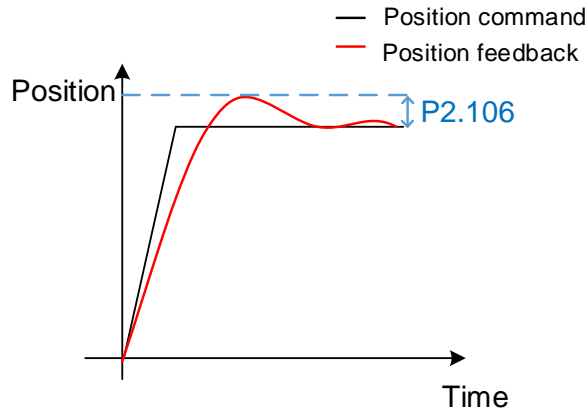

Parameter setting range: 1 to (2<sup>24</sup> × 3) (unit: pulse); default: 2000

P2.106 = 1	P2.106 = 30000
<p>Allowable amount of overshoot ≤ 1 pulse Settling time: 59.2 ms</p>	<p>Allowable amount of overshoot ≤ 30000 pulses Settling time: 12.4 ms</p>

### 5.4.6 Alarms related to auto tuning

In Auto Tuning mode, it is vital that you program the command path. The path must contain the operation cycle (including acceleration, constant speed, and deceleration) and dwell time. See the following figure. When any of the settings is incorrect, the servo drive stops tuning and displays an alarm. Check the alarm causes and take corrective actions.

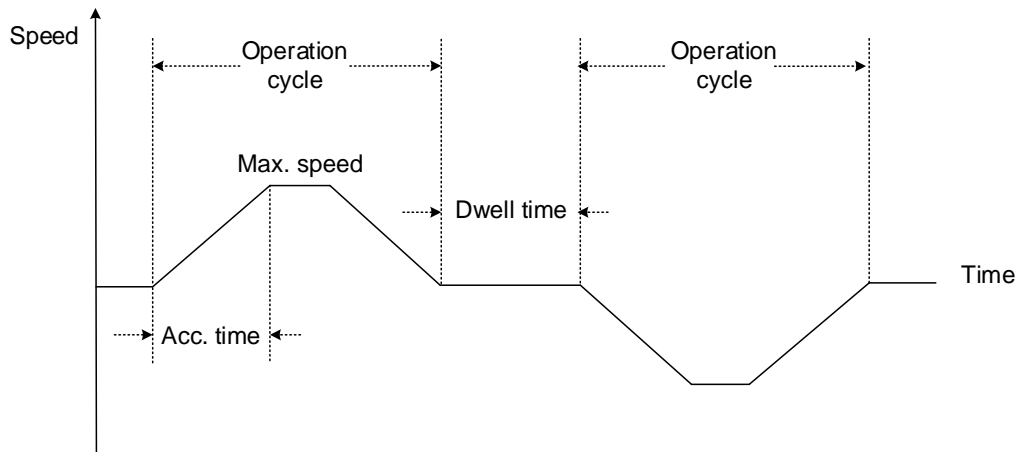

Alarm	Alarm name
AL08A	Auto-tuning function - command error
AL08B	Auto-tuning function - dwell time is too short
AL08C	Auto-tuning function - inertia estimation error

## 5

## 5.5 Gain adjustment modes

In addition to the Auto Tuning function, the servo drive also provides the following gain adjustment modes. You can easily complete tuning by increasing or decreasing the bandwidth response level (P2.031) or the bandwidth for speed loop response (P2.126). Follow the tuning procedure in Section 5.1.

### 5.5.1 Differences between gain adjustment modes

Level adjustment: set the response level with P2.031 to adjust the servo bandwidth. With the load inertia ratio or total weight increased or decreased, the bandwidth corresponding to the response level set by P2.031 changes as well.

Bandwidth adjustment: set P2.126 to directly determine the servo bandwidth, which fine-tunes the bandwidth.

P2.032	Adjustment mode	Mode name	Inertia (weight) estimation	Parameter	
				Manual	Auto
0	Manual	Manual mode	Fixed set value of P1.037	P1.037, P2.000, P2.004, P2.006, P2.023, P2.024, P2.025, P2.043, P2.044, P2.045, P2.046, P2.049, P2.089, P2.098, P2.099, P2.101, P2.102	N/A
1	Gain adjustment mode 1	<b>Level adjustment - Auto</b>	Real-time estimation	P2.031	P1.037, P2.000, P2.004, P2.006, P2.023, P2.024, P2.025, P2.043, P2.044, P2.045, P2.046, P2.049, P2.089, P2.098, P2.099, P2.101, P2.102
2	Gain adjustment mode 2	<b>Level adjustment - Semi-auto</b>	Fixed set value of P1.037	P1.037 P2.031	P2.000, P2.004, P2.006, P2.023, P2.024, P2.025, P2.043, P2.044, P2.045, P2.046, P2.049, P2.089, P2.098, P2.099, P2.101, P2.102
3	Gain adjustment mode 3 (Available when two degree of freedom control function is enabled)	<b>Level adjustment - Two degree of freedom</b>	Fixed set value of P1.037	P1.037 P2.031 P2.089	P2.000, P2.004, P2.006, P2.023, P2.024, P2.025, P2.043, P2.044, P2.045, P2.046, P2.049, P2.089, P2.098, P2.099, P2.101, P2.102
4	Gain adjustment mode 4	-	Reset to the default gain values	-	-

P2.032	Adjustment mode	Mode name	Inertia (weight) estimation	Parameter	
				Manual	Auto
5	Gain adjustment mode 5 (Same as setting P2-32 = 1 for the A2 series)	<b>Bandwidth adjustment - Auto</b>	Real-time estimation	P2.126	P1.037, P2.000, P2.004, P2.006, P2.023, P2.024, P2.025, P2.043, P2.044, P2.045, P2.046, P2.049, P2.089, P2.094, P2.098, P2.099, P2.101, P2.102
6	Gain adjustment mode 6 (Same as setting P2-32 = 2 for the A2 series)	<b>Bandwidth adjustment - Semi-auto</b>	Fixed set value of P1.037	P1.037 P2.126	P2.000, P2.004, P2.006, P2.023, P2.024, P2.025, P2.043, P2.044, P2.045, P2.046, P2.049, P2.089, P2.094, P2.098, P2.099, P2.101, P2.102

Note: when the two degree of freedom control function is disabled (P2.094 [Bit 12] = 0), the effect of Gain adjustment mode 3 is the same as that of Gain adjustment mode 2, so setting P2.089 is invalid in that scenario.

5

5.5.2 Flowchart of gain adjustment mode

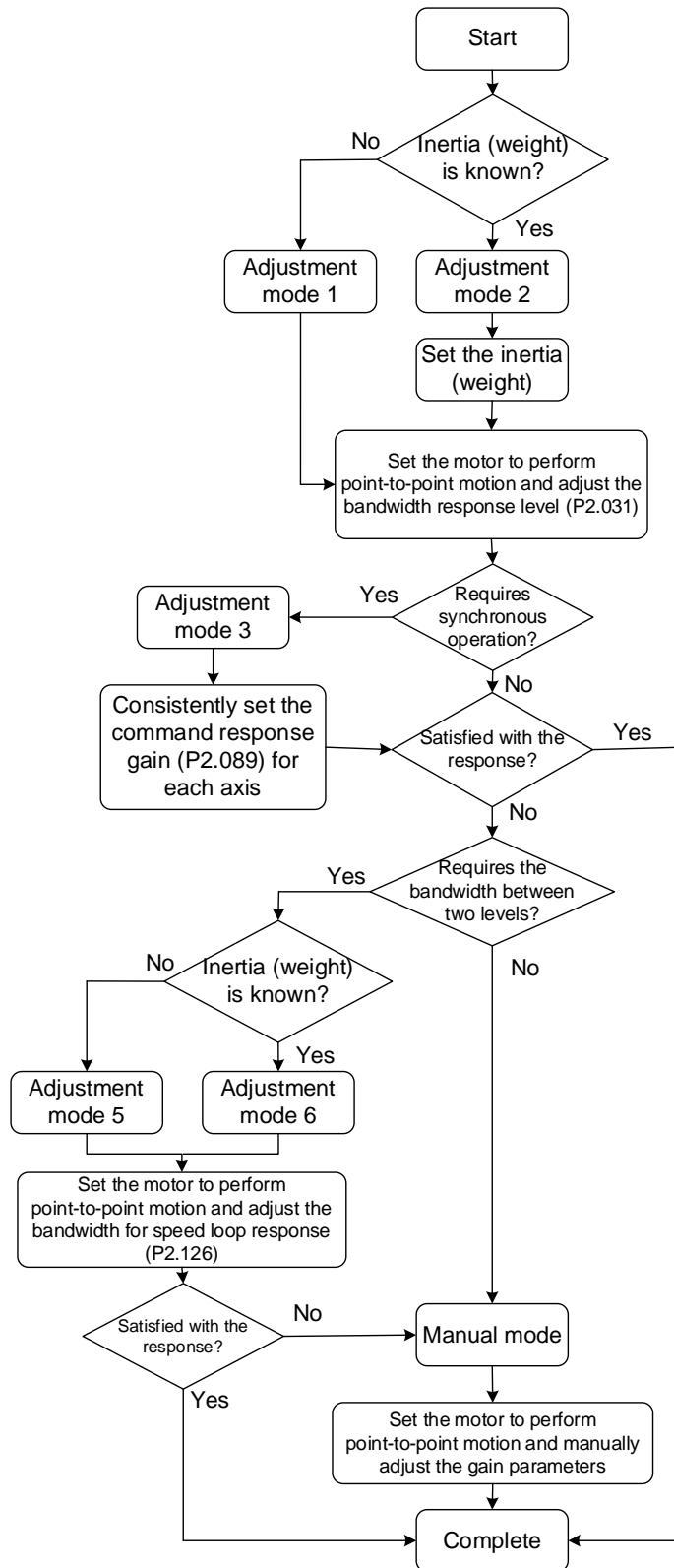

Note: Gain adjustment modes 5 and 6 are similar to Gain adjustment modes 1 and 2 respectively. The main difference is that you can set the bandwidth for modes 5 and 6.

### 5.5.3 Gain adjustment mode 1

You can use this mode when the load inertia (weight) is unknown or the inertia (weight) changes during machine operation.

The servo drive continually estimates the machine inertia (weight) and updates the value of P1.037. To reach the expected response, simply adjust the bandwidth response level (P2.031).

P2.032	Adjustment mode	Mode name	Inertia (weight) estimation	Parameter	
				Manual	Auto
1	Gain adjustment mode 1	Level adjustment - Auto	Real-time estimation	P2.031	P1.037, P2.000, P2.004, P2.006, P2.023, P2.024, P2.025, P2.043, P2.044, P2.045, P2.046, P2.049, P2.089, P2.098, P2.099, P2.101, P2.102

### 5.5.4 Gain adjustment mode 2

When the inertia (weight) cannot be successfully estimated in Gain adjustment mode 1, it is probably because the machine inertia ratio is greater than 100 times (or the weight is greater than 200 kg) or the speed and acceleration / deceleration of the actual motor operation are too low. In this case, you can use Gain adjustment mode 2 to tune the servo system.

In Gain adjustment mode 2, you need to correctly set the machine inertia ratio or total weight in P1.037 first and then adjust the bandwidth response level (P2.031) to reach the expected response.

Note: inertia (weight) estimation is available for most machines. However, when the machine does not comply with the requirements for inertia (weight) estimation, you have to set the correct inertia ratio or total weight in P1.037.

P2.032	Adjustment mode	Mode name	Inertia (weight) estimation	Parameter	
				Manual	Auto
2	Gain adjustment mode 2	Level adjustment - Semi-auto	Fixed set value of P1.037	P1.037 P2.031	P2.000, P2.004, P2.006, P2.023, P2.024, P2.025, P2.043, P2.044, P2.045, P2.046, P2.049, P2.089, P2.098, P2.099, P2.101, P2.102



5

**5.5.5 Gain adjustment mode 3**

When Gain adjustment modes 1 and 2 cannot meet the requirements, try Gain adjustment mode 3 to tune the servo system. P2.089 (Command response gain) is available for manual adjustment in this mode. You can increase the gain value to shorten the response and settling time for the position command. However, if you set the parameter value too high, it might cause position overshoot and machinery vibration. This parameter is effective only when the commands are changing, such as in the acceleration / deceleration application, and adjusting this parameter can improve the response. However, when the two degree of freedom control function is disabled (P2.094 [Bit 12] is set to 0), the effect of Gain adjustment mode 3 is the same as that of Gain adjustment mode 2, so setting P2.089 is invalid in that scenario.

P2.032	Adjustment mode	Mode name	Inertia (weight) estimation	Parameter	
				Manual	Auto
3	Gain adjustment mode 3 (Available when two degree of freedom control function is enabled)	Level adjustment - Two degree of freedom	Fixed set value of P1.037	P1.037 P2.031 P2.089	P2.000, P2.004, P2.006, P2.023, P2.024, P2.025, P2.043, P2.044, P2.045, P2.046, P2.049, P2.098, P2.099, P2.101, P2.102

### 5.5.6 Gain adjustment mode 4

When P2.032 is set to 4, the setting value of P2.032 is restored to the value set before initialization other than the default value after parameter reset (P2.008 = 10). For example, if P2.032 is 1, P2.032 is still 1 after gain initialization (P2.032 = 4).

Original setting value of P2.032	0	1	2	3
Setting value of P2.032 after parameter reset (P2.008 = 10)	1	1	1	1
Setting value of P2.032 after gain initialization (P2.032 = 4)	0	1	2	3

When P2.032 is set to 4, if the notch filters are set to Manual for manual resonance suppression, the related notch filter parameters are not reset. If the notch filters are automatically set, the related notch filter parameters and the parameters in the following tables are reset to the default.

The default values of other related parameters are as follows.

Gain parameters			Filter and resonance suppression parameters		
Parameter No.	Default	Function	Parameter No.	Default	Function
P1.037	6.0	Load inertia ratio or total weight	P1.025	100.0	Low-frequency vibration suppression frequency 1
P2.000	36	Position control gain	P1.026	0	Low-frequency vibration suppression gain 1
P2.004	144	Speed control gain	P1.027	100.0	Low-frequency vibration suppression frequency 2
P2.006	23	Speed integral compensation	P1.028	0	Low-frequency vibration suppression gain 2
P2.031	19	Bandwidth response level	P2.023	1000	Notch filter 1 - frequency
P2.089	23	Command response gain	P2.024	0	Notch filter 1 - attenuation level
P2.105	11	Automatic gain adjustment level 1	P2.025*	5.0	Resonance suppression low-pass filter
P2.106	2000	Automatic gain adjustment level 2	P2.043	1000	Notch filter 2 - frequency
			P2.044	0	Notch filter 2 - attenuation level
			P2.045	0	Notch filter 3 - frequency
			P2.046	0	Notch filter 3 - attenuation level
			P2.047	1	Auto resonance suppression mode
			P2.049*	5.0	Speed detection filter and jitter suppression
			P2.098	1000	Notch filter 4 - frequency
			P2.099	5	Notch filter 4 - attenuation level
			P2.101	100	Notch filter 5 - frequency
			P2.102	0	Notch filter 5 - attenuation level

Note: when P2.032 is set to 0 and then 4, the default settings of P2.025 and P2.049 are both 0.8.

## 5

### 5.5.7 Gain adjustment mode 5

You can use this mode when the load inertia (weight) is unknown or the inertia (weight) changes during machine operation.

The servo drive continually estimates the machine inertia (weight) and updates the value of P1.037. To reach the expected response, simply set the bandwidth for speed loop response (P2.126) to adjust the servo stiffness or reduce the noise.

P2.032	Adjustment mode	Mode name	Inertia (weight) estimation	Parameter	
				Manual	Auto
5	Gain adjustment mode 5 (Same as setting P2-32 = 1 for the A2 series)	Bandwidth adjustment - Auto	Real-time estimation	P2.126	P1.037, P2.000, P2.004, P2.006, P2.023, P2.024, P2.025, P2.043, P2.044, P2.045, P2.046, P2.049, P2.089, P2.094, P2.098, P2.099, P2.101, P2.102

### 5.5.8 Gain adjustment mode 6

When the inertia (weight) cannot be successfully estimated in Gain adjustment mode 5, it is probably because the machine inertia ratio is greater than 100 times (or the weight is greater than 200 kg) or the speed and acceleration / deceleration of the actual motor operation are too low. In this case, you can use Gain adjustment mode 6 to tune the servo system.

In Gain adjustment mode 6, you need to correctly set the machine inertia ratio or total weight in P1.037 first and then adjust the bandwidth for speed loop response (P2.126). Setting P2.126 higher can increase the servo stiffness and setting P2.126 lower can reduce the noise.

P2.032	Adjustment mode	Mode name	Inertia (weight) estimation	Parameter	
				Manual	Auto
6	Gain adjustment mode 6 (Same as setting P2-32 = 2 for the A2 series)	Bandwidth adjustment - Semi-auto	Fixed set value of P1.037	P1.037 P2.126	P2.000, P2.004, P2.006, P2.023, P2.024, P2.025, P2.043, P2.044, P2.045, P2.046, P2.049, P2.089, P2.094, P2.098, P2.099, P2.101, P2.102

## 5.5.9 Parameters related to gain adjustment modes

### 5.5.9.1 Bandwidth response level (P2.031) - stiffness adjustment

This parameter enables you to tune the servo drive in a simple and instinctive way. When the inertia (weight) is fixed and you increase the bandwidth response level (P2.031), the servo's bandwidth increases as well. If resonance occurs, decrease the setting value of P2.031 by one or two bandwidth response levels (you should adjust the bandwidth response level according to the actual situation). For instance, if the value of P2.031 is 30, you can lower the setting to 28. When you adjust the value of this parameter, the servo drive automatically adjusts the corresponding gain parameters, such as P2.000 and P2.004.

Note: enabling the bandwidth response level reversion function (P2.125 [Bit 3]) is recommended when you are adjusting the bandwidth response level (P2.031).

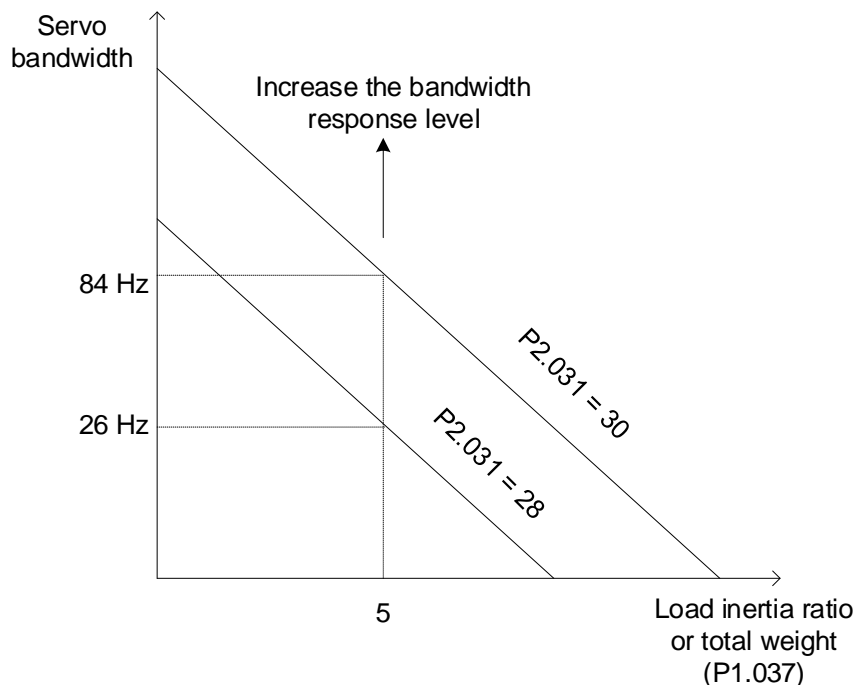

#### Bandwidth response level reversion (P2.125 [Bit 3])

When the bandwidth response level reversion function is enabled (P2.125 [Bit 3] = 1), the servo automatically sets the upper limit for the setting value of P2.031 to reduce hazards caused by resonance.

When the bandwidth response level reversion function is enabled, resonance caused by increasing P2.031 can be suppressed with the Notch filter. When any of the 5 sets of Notch filter is not set, the servo automatically sets that Notch filter for resonance suppression. If the resonance cannot be suppressed when P2.031 is increased, the servo automatically decreases P2.031 to the level where the resonance does not occur, and then the servo sets the last set value of P2.031 before it is decreased as the upper limit of P2.031. If requiring to further increase P2.031, disable the bandwidth response level reversion function and the upper limit is lifted.

## 5

### 5.5.9.2 Command response gain (P2.089) - response adjustment

Use P2.089 to adjust the command response gain to improve the response to the servo command. Increasing the gain can reduce the transient error between the position command and command response (in acceleration and deceleration zones). That is, the setting is effective only when the commands are changing. This parameter is available only when the two degree of freedom control function is enabled (P2.094 [Bit 12] = 1) in Position mode. (The two degree of freedom control function is enabled by default).

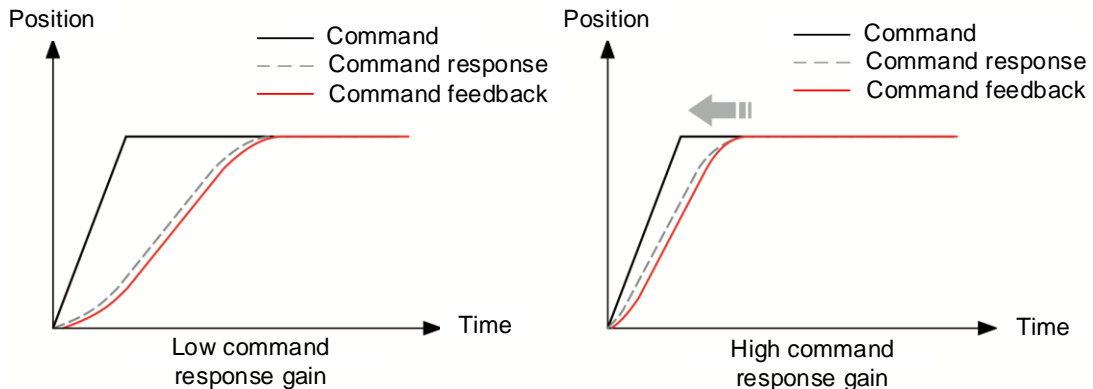

### 5.5.9.3 Bandwidth for speed loop response (P2.126) - bandwidth adjustment

P2.126 sets the bandwidth for the speed loop, and the corresponding position loop bandwidth and the speed loop bandwidth are at a fixed ratio. To fine-tune the ratio between the position bandwidth and speed bandwidth (P2.000 and P2.004) or the ratio between the proportional gain (P2.004) and integral gain (P2.006) of the speed loop, switch the system to Manual mode for operation.

Assuming that the bandwidth setting of P2.126 = BW, the recommended settings for the gain parameters are as follows.

- $P2.000 = P2.004 / 4$
- $P2.004 = BW * 2 * \pi$
- $P2.006 = BW$
- $P2.026 = BW$

## 5.6 Manual tuning of gain parameters

The position or speed response bandwidth is determined by the mechanical stiffness and the application. Generally, for applications or machines that require high-speed positioning and high precision, higher response bandwidth is required. However, increasing the response bandwidth is likely to cause mechanical resonance. Thus, machinery with higher stiffness is used to solve this problem. When the response bandwidth of the machine is unknown, you can gradually increase the gain parameter values to increase the response bandwidth. Then, decrease the gain parameter values until you hear the sound of the resonance. The following are the descriptions of the gain adjustment parameters.

- Position control gain (KPP, P2.000)

This parameter determines the response of the position control circuit. The bigger the KPP value, the higher the bandwidth of the position loop. This lowers the following error and position error, and shortens the settling time. However, if you set the value too high, it can cause machine jitter or cause overshoot when positioning. The calculation of position loop bandwidth is as follows:

$$\text{Position loop bandwidth (Hz)} = \frac{KPP}{2\pi}$$

- Speed control gain (KVP, P2.004)

This parameter determines the response of the speed control circuit. The bigger the KVP value, the higher the bandwidth of the speed loop and the lower the following error. However, if you set the value too high, it is likely to cause mechanical resonance. The speed loop bandwidth must be 4 times (or more) the position loop bandwidth; otherwise, it can cause machine jitter or cause overshoot when positioning. The calculation of speed loop bandwidth is as follows:

$$\text{Speed loop bandwidth (Hz)} = \left(\frac{KVP}{2\pi}\right) \times \left[\frac{(1 + P1.037 / 10)}{(1 + JL / JM)}\right]$$

JM: motor inertia (weight); JL: load inertia (weight)

The following table illustrates the changes in position feedback when the speed loop bandwidth is 1 time, 2 times, and 4 times the position loop bandwidth.

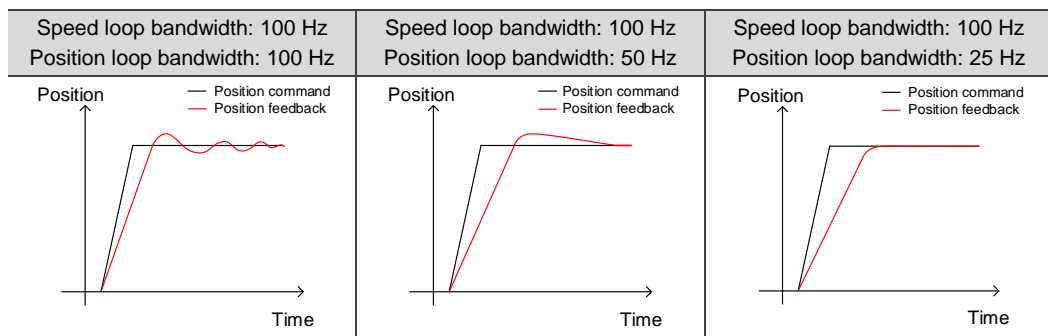

## 5

When P1.037 (auto estimation or manually set value) is equal to the actual load inertia ratio or weight (JL / JM), the actual speed loop bandwidth is:

$$\text{Speed loop bandwidth (Hz)} = \left( \frac{KVP}{2\pi} \right)$$

- Speed integral compensation (KVI, P2.006)

The higher the KVI value, the better the elimination of the deviation. However, if you set the value too high, it can cause machine jitter. It is advisable to set the value as follows:

$$KVI \leq 1.5 \times \text{Speed loop bandwidth (Hz)}$$

- Resonance suppression low-pass filter (NLP, P2.025)

A high load inertia ratio or total weight reduces the speed loop bandwidth. Therefore, you must increase the KVP value to maintain the speed loop bandwidth. Increasing the KVP value might cause mechanical resonance. Use this parameter to eliminate the noise. The higher the value, the better the capability of reducing high-frequency noise. However, if you set the value too high, it can cause instability in the speed control circuit and overshoot. It is advisable to set the value as follows:

$$NLP \leq \frac{10000}{6 \times \text{Speed loop bandwidth (Hz)}}$$

- Anti-interference gain (DST, P2.026)

Use this parameter to increase the ability to resist external force and reduce overshoot during acceleration / deceleration. The default value is 0. Adjusting this value in Manual mode is not suggested unless it is for fine-tuning the results of auto tuning.

Note: this gain parameter is not available when the two degree of freedom control function is enabled (P2.094 [Bit 12] = 1).

- Position feed forward gain (PFG, P2.002)

This parameter can reduce the position error and shorten the settling time. However, if you set the value too high, it might cause overshoot when positioning. When the resolution of the pulse command is low, adjusting this parameter might cause noise. In this case, try using P2.003, P1.008, and P1.068 to eliminate the noise.

5.6.1 Flowchart of manual tuning in Speed mode

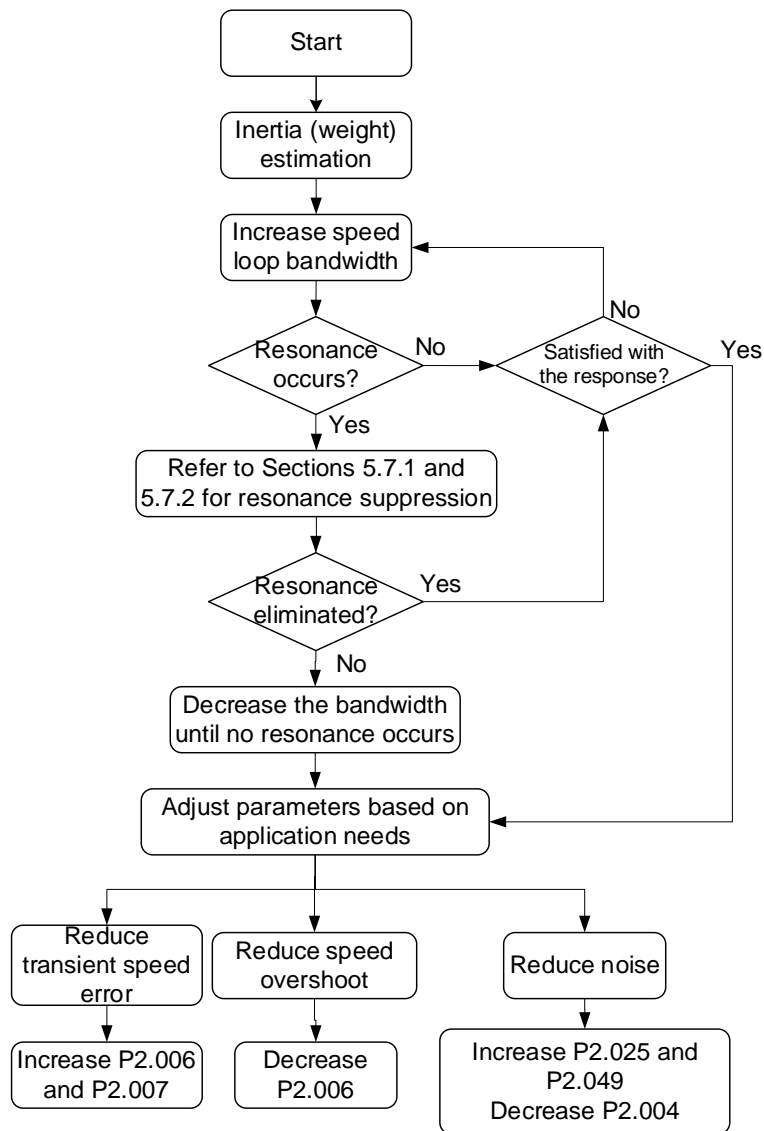



5

5.6.2 Flowchart of manual tuning in Position mode

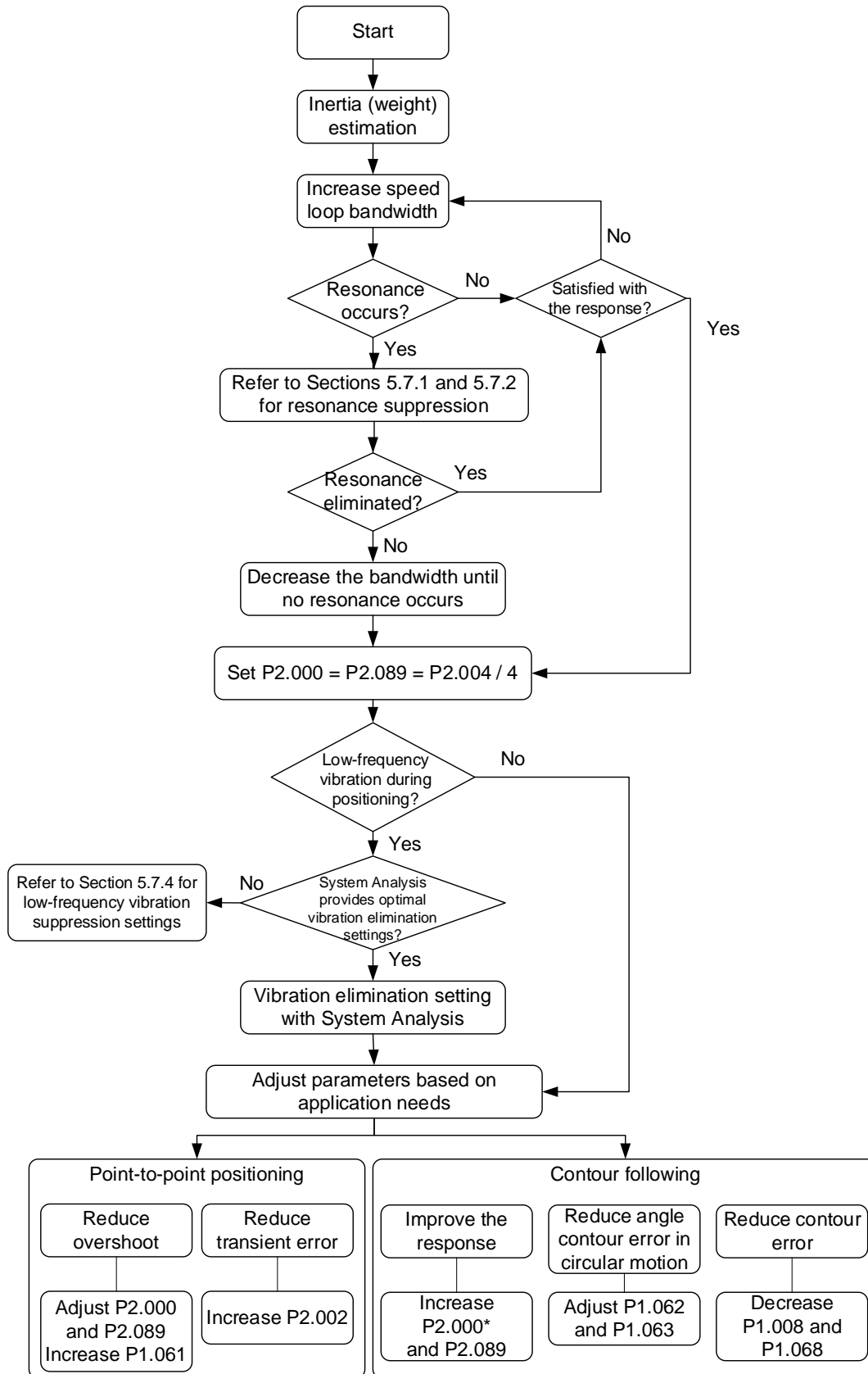

Note: it is advisable to set P2.004 four times (or more) the setting value of P2.000; otherwise a jitter occurs in the corner contour.

### 5.6.3 Manual tuning with ASDA-Soft

1. Select **[Mode 0] Manual Mode**.
2. Click **Inertia estimation**.
3. Set the bandwidth, click **Gain Calculation**, and the Calculation Result field on the right shows the corresponding parameter settings according to the set speed loop bandwidth.
4. Fine-tune the values in the Calculation Result field. It is advisable to set P2.004 four times (or more) the setting value of P2.000.
5. After fine-tuning the parameters, click the  button to write the parameters to the servo drive.

Note: for parameter settings of the two degree of freedom control function in Manual mode (P2.032 = 0), refer to Section 5.7.5.3.

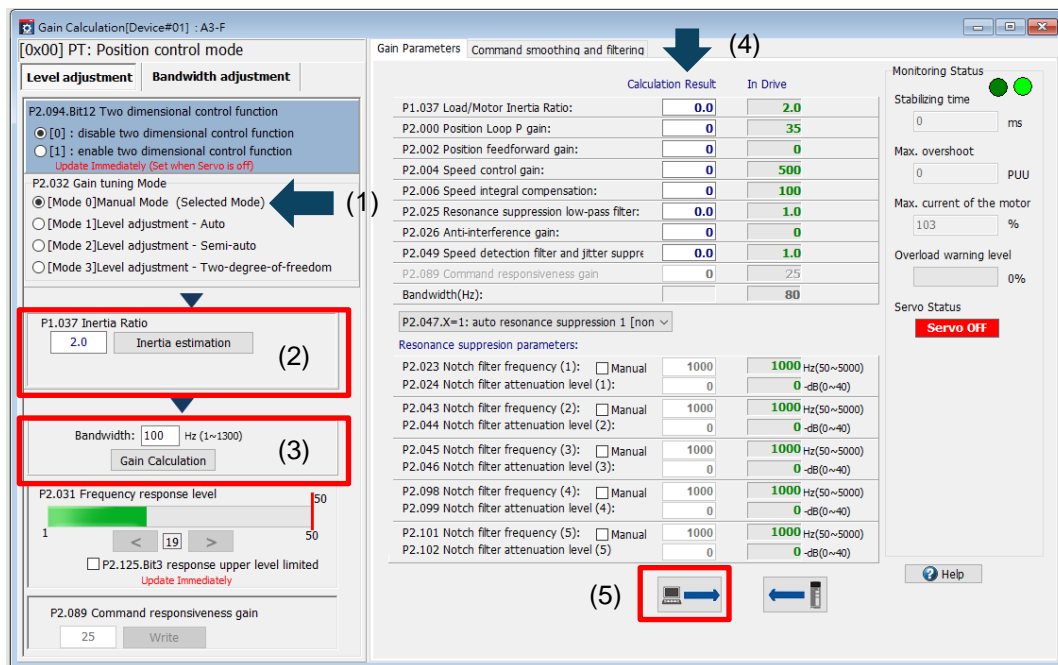

# 5

## 5.7 Mechanical resonance suppression and noise elimination

When mechanical resonance occurs, it is probably because the stiffness of the control system is too high or the response bandwidth is too great. Eliminating these two factors can improve the situation. During the tuning process, when you gradually increase the servo response bandwidth, the frequency at the resonance point is likely to be reached, causing noise and vibration. In this case, use the following filters to effectively eliminate the noise and vibration and therefore increase the response bandwidth.

### Block diagram of filter setting

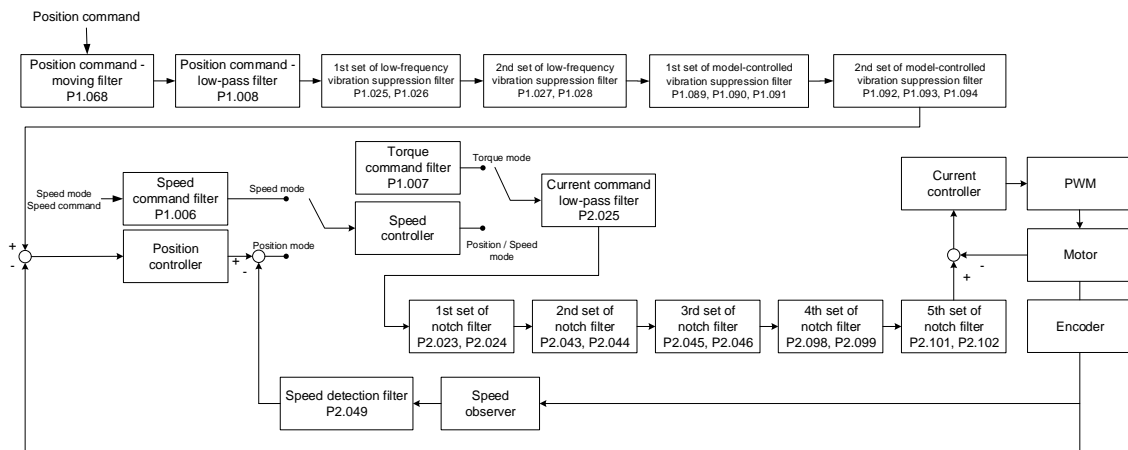

## 5.7.1 Notch filter

### 5.7.1.1 Function restriction

1. The Notch filter frequency settings (P2.023, P2.043, P2.045, P2.098, and P2.101) must be 2 times (or more) the speed loop bandwidth ( $P2.004 / 2\pi$ ), or it might lead to system divergence.
2. It is recommended that the notch depth (magnitude) of the resonance point should remain at -15 to -10 dB after resonance suppression.

Note: it is recommended that you set the Analysis Type to **Speed Open-loop** in the System Analysis of ASDA-Soft; the zero-crossing frequency is the speed loop bandwidth.

### 5.7.1.2 Function description

The servo provides 5 sets of notch filters with the frequency setting range of 50 to 5000 Hz. Each set of notch filter supports the function of auto resonance suppression (P2.047 and P2.048). In addition, you can suppress the resonance manually. The precautions and operation procedure for manual resonance suppression are as follows.

- Use the **System Analysis** function in ASDA-Soft V6 to find the resonance frequency.
- The sudden loss of load inertia (weight) is likely to cause resonance. It is advisable to tune the servo drive at maximum load.
- If the resonance frequency is incorrectly set, the noise and vibration might be worse.
- The higher the attenuation level and Q factor, the better the effect of resonance suppression. However, if the values are set too high, it results in phase lag and causes resonance at other frequencies.

Flowchart of manual resonance suppression:

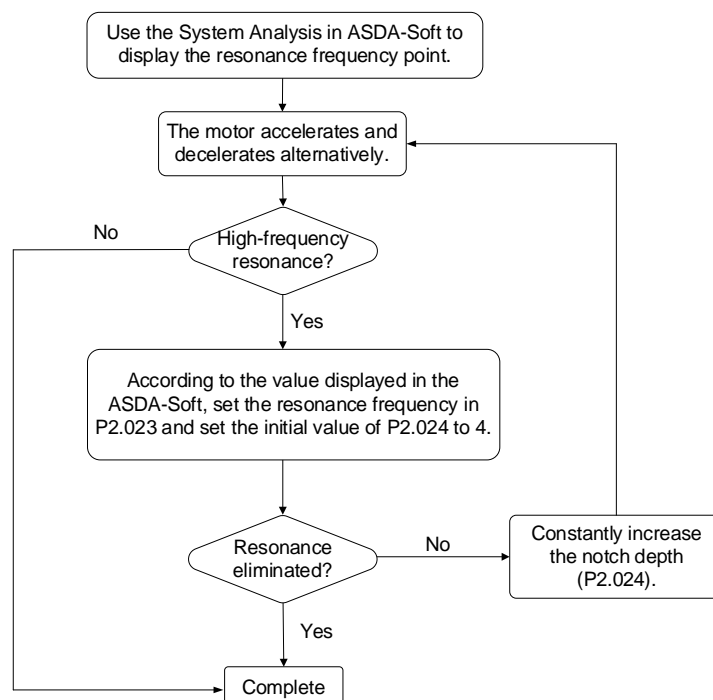

## 5

### 5.7.1.3 Parameter descriptions

A notch filter is used to remove frequencies within a specific range. You can set the three parameters, including frequency, attenuation level, and Q factor, for each set of notch filter. The following describes the parameters of attenuation level (notch depth) and Q factor.

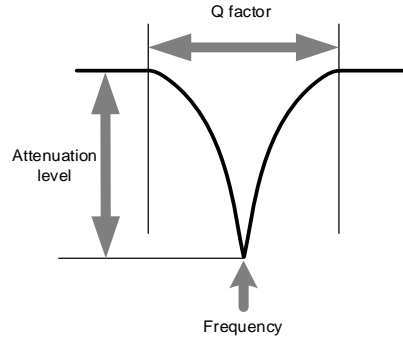

#### Attenuation level of notch filter

The attenuation level of the notch filter determines the notch depth (magnitude) of the frequency to be filtered. Properly set the attenuation level to effectively suppress the vibration. The higher the setting value, the better the effect of resonance suppression, but the phase margin of the system becomes smaller. When you set the value too high, the phase margin may become insufficient, causing resonance at other frequencies.

When the attenuation level of the notch filter is set to 0, it means the filter function is disabled.

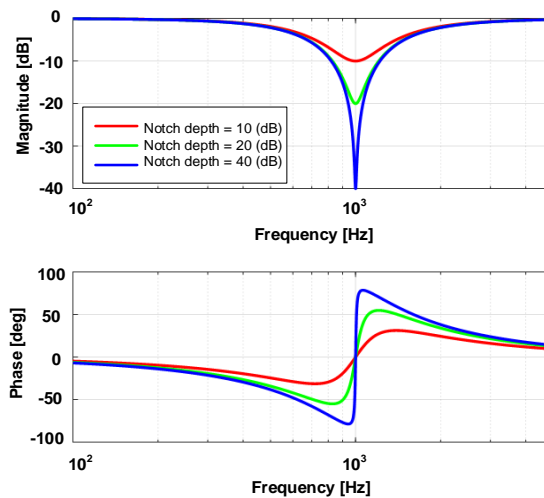

### Q factor of notch filter

The Q factor of the notch filter determines the frequency range (amount of signal) around the specific frequency to be filtered. **The higher the Q factor, the narrower the filtered frequency band**, and thus the phase margin of the system is **less** affected. In general, for systems with higher inertia (weight) or lower stiffness, the Q factor at the resonance point is relatively high. If the Q factor is set too high, the resonance cannot be completely suppressed, and it is likely to cause resonance at the cut-off frequencies around the resonance point. In this case, set the Q factor lower to improve the condition.

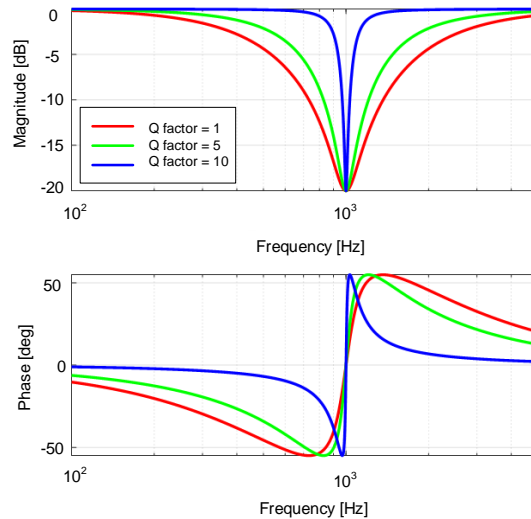

## 5

## 5.7.1.4 Application example

It is advisable to perform domain-frequency analysis and time-domain analysis alternately for comparing and monitoring the results.

## Frequency-domain analysis

Draw Bode plots by setting the Analysis Type to **Speed Open-loop** in the System Analysis of ASDA-Soft. The following figure shows the speed open-loop gain with resonance and (1) indicates the resonance point. Set the frequency at the resonance point as the frequency of the notch filter and gradually increase the attenuation level (magnitude) of the notch filter in the corresponding parameter. When increasing the notch depth, you can set the Analysis Type to **Speed Open-loop** in the System Analysis\* to check if the resonance point is neutralized. If the notch depth is too shallow, resonance might occur in the system again. If the notch depth is too deep, the phase margin of the system will be sacrificed, making it difficult to increase the bandwidth afterwards. It is recommended that the notch depth (magnitude) of the resonance point should remain at -15 to -10 dB after resonance suppression.

Note: when the frequency setting is lower than 100 Hz, it is advisable to select the check box for **Enable Low Frequency Analysis** in the System Analysis of ASDA-Soft. If the check box is not selected, the zero-crossing frequency might not be correctly detected or the low-frequency resonance point might be ignored or regarded as noise.

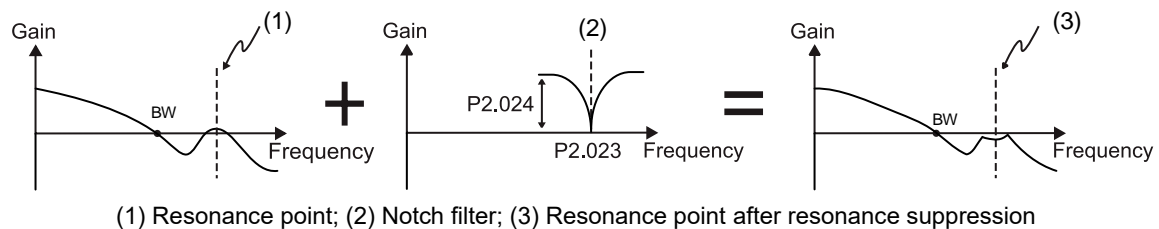

## Time-domain analysis

1. Execute the Scope function in ASDA-Soft and select **Motor Current: Percentage [%]** for the channel.
2. Click **Run**, and the scope collects the current data when the motor is operating.
3. Click **Stop**, and the operation status of the motor is displayed in the software interface.
4. Select the check box for **FFT Display**, then left-click and drag the mouse to select the area with data displayed, and the spectrum appears on the screen.

5

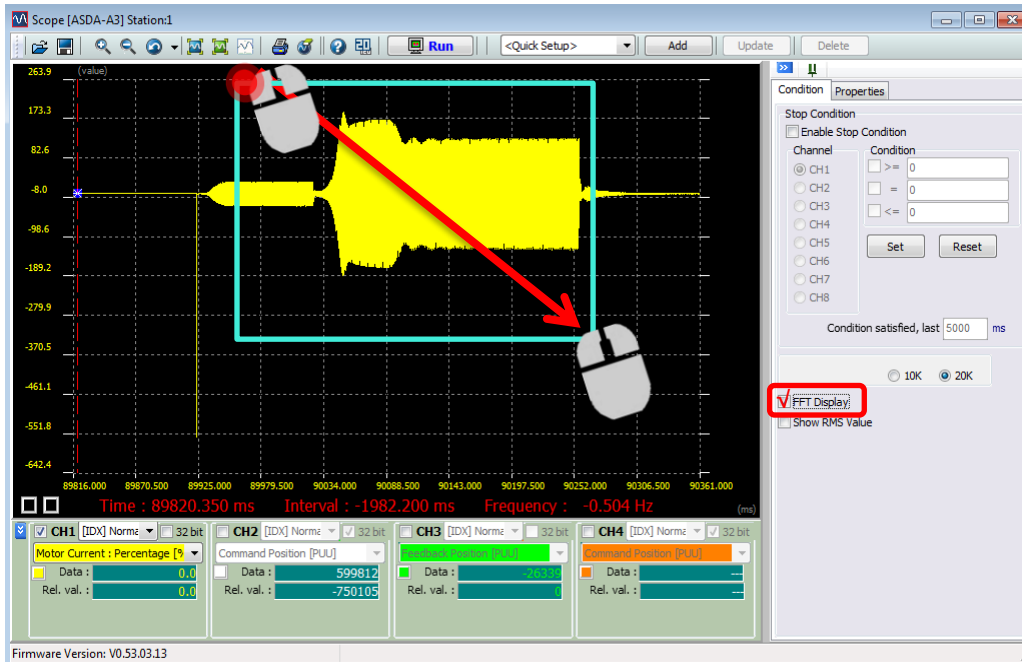



5

According to the spectrum, we can find two resonance points at the frequencies of 1015 Hz and 2890 Hz. In the following figure, P2.047.X is set to 1 or 2 for the servo to automatically fill in the resonance suppression parameters. To set the resonance points for manual resonance suppression, select the check box for **Manual** under the specific set of notch filter, and then the corresponding bit of P2.047.Y or P2.047.Z is automatically set to 1. In this case, you can manually set the resonance suppression parameters.

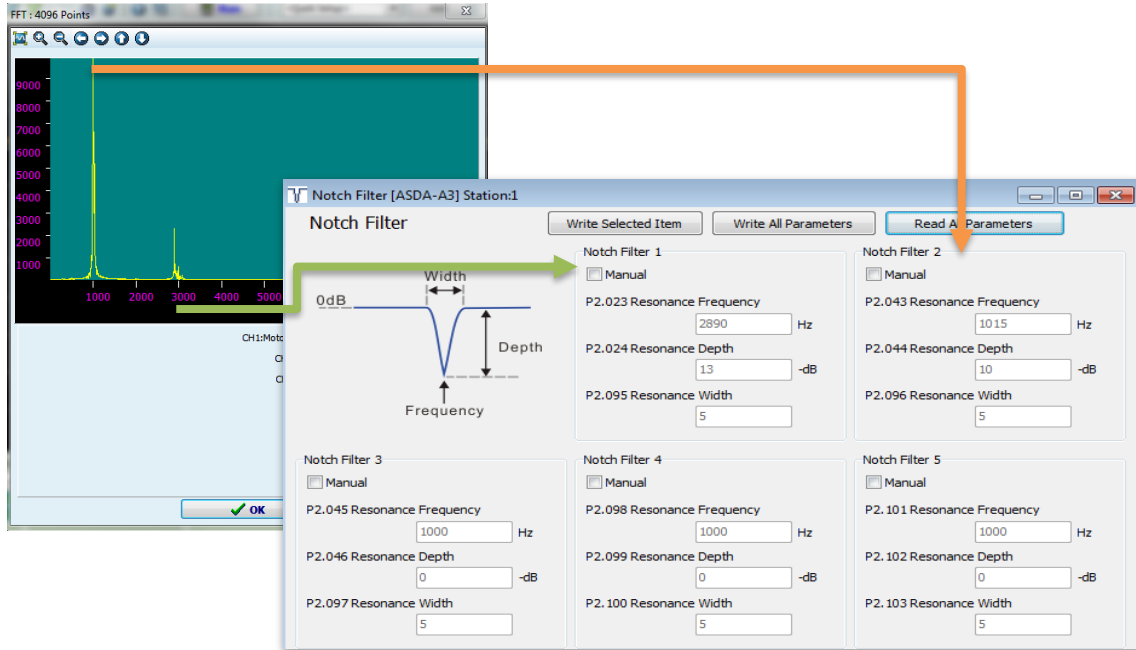

Relevant parameter

Refer to Chapter 8 for detailed descriptions of the relevant parameters.

Parameter	Function
P2.023	Notch filter 1 - frequency
P2.024	Notch filter 1 - attenuation level
P2.043	Notch filter 2 - frequency
P2.044	Notch filter 2 - attenuation level
P2.045	Notch filter 3 - frequency
P2.046	Notch filter 3 - attenuation level
P2.047	Auto resonance suppression mode
P2.048	Auto resonance detection level
P2.095	Notch filter 1 - Q factor
P2.096	Notch filter 2 - Q factor
P2.097	Notch filter 3 - Q factor
P2.098	Notch filter 4 - frequency
P2.099	Notch filter 4 - attenuation level
P2.100	Notch filter 4 - Q factor
P2.101	Notch filter 5 - frequency
P2.102	Notch filter 5 - attenuation level
P2.103	Notch filter 5 - Q factor

## 5.7.2 Resonance suppression low-pass filter

### 5.7.2.1 Function restriction

It is recommended that the filter bandwidth ( $1000 / P2.025$ ) should be 8 times (or more) the speed loop bandwidth ( $P2.004 / 2\pi$ ).

Note: it is recommended that you set the Analysis Type to **Speed Open-loop** in the System Analysis of ASDA-Soft; the zero-crossing frequency is the speed loop bandwidth.

### 5.7.2.2 Function description

The current command generated in the speed loop is filtered by the resonance suppression low-pass filter, which reduces the interference of high-frequency resonance or noise to current control. Since the filter causes a delay in the current command, when increasing the servo response bandwidth, you must set the time constant for the low-pass filter (P2.025) smaller. However, it causes greater noise during motor operation.

### 5.7.2.3 Application example

Draw Bode plots by setting the Analysis Type to **Speed Open-loop** in the System Analysis of ASDA-Soft. When there is more than one resonance point and the distance between each is small, it is advisable to use the resonance suppression low-pass filter to suppress the resonance occurring at the resonance points within a specified range.

If the resonance frequency is known, the Notch filter works better than the resonance suppression low-pass filter for resonance suppression. If the spectrum displays multiple resonance points which are intensively distributed, or the resonance frequency drifts significantly with time or due to other causes, use the resonance suppression low-pass filter instead.

When P2.025 is gradually increased, the filter bandwidth becomes smaller. Although resonance does not occur in this condition, the servo response is slower and the phase margin is reduced. If the ratio between the filter bandwidth ( $1000 / P2.025$ ) and speed loop bandwidth ( $P2.004 / 2\pi$ ) is too small, the system becomes unstable.

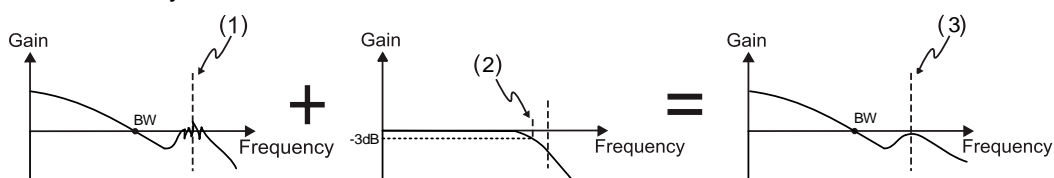

(1) Resonance point;

(2) Resonance suppression low-pass filter (Cut-off frequency of low-pass filter =  $1000 / P2.025$  Hz);

(3) Resonance point after resonance suppression

#### Relevant parameter

Refer to Chapter 8 for detailed descriptions of the relevant parameter.

Parameter	Function
P2.025	Resonance suppression low-pass filter

# 5

## 5.7.3 Speed detection filter

### 5.7.3.1 Function restriction

It is recommended that the filter bandwidth ( $1000 / P2.049$ ) should be 8 times (or more) the speed loop bandwidth ( $P2.004 / 2\pi$ ).

Note: it is recommended that you set the Analysis Type to **Speed Open-loop** in the System Analysis of ASDA-Soft; the zero-crossing frequency is the speed loop bandwidth.

### 5.7.3.2 Function description

When the motor speed is unstable, use this function to reduce the jitter in the motor speed. You can obtain the speed information after the position feedback signal from the encoder is processed by the speed observer. You can use the Scope function of ASDA-Soft to monitor the speed signal processed by the speed detection filter by setting the channel to **Motor speed: real-time [rpm]**.

Note: set the channel to **Motor speed: real-time [mm/s]** for monitoring the speed of linear motors.

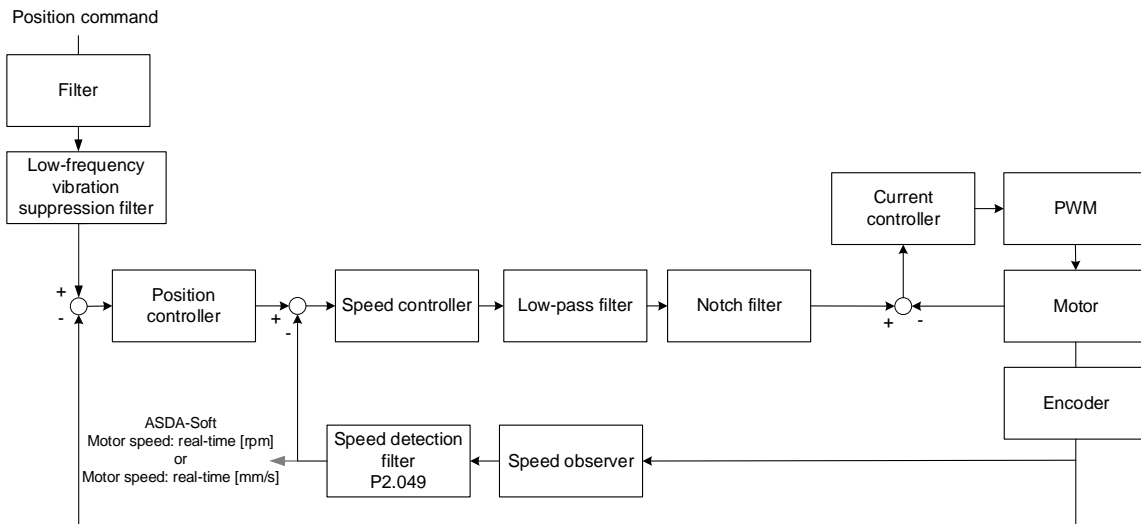

You can set P2.084.U to select the speed observer.

P2.084.U	Speed observer	Filter bandwidth	Applicable range
0	Speed observer 1	$1000 / P2.049$	Available for high resolution encoders.
1	Speed observer 2	The bandwidth cannot be adjusted.	Available for encoders or linear scales with low resolution, such as rotary encoders with the single-turn resolution smaller than 40000 pulse/rev used in low speed (< 100 rpm) application, or linear encoders with the resolution greater than 5 $\mu\text{m}/\text{pulse}$ .
2	Speed observer 3	$1000 / P2.049$	

### 5.7.3.3 Application example

The following figure illustrates the difference between setting P2.049 to 0.8 and 10.8 when the speed observer 1 is used (P2.084.U = 0). You need to select a suitable speed observer for different installation methods for mechanical parts or different motors and then verify if the results meet the requirements.

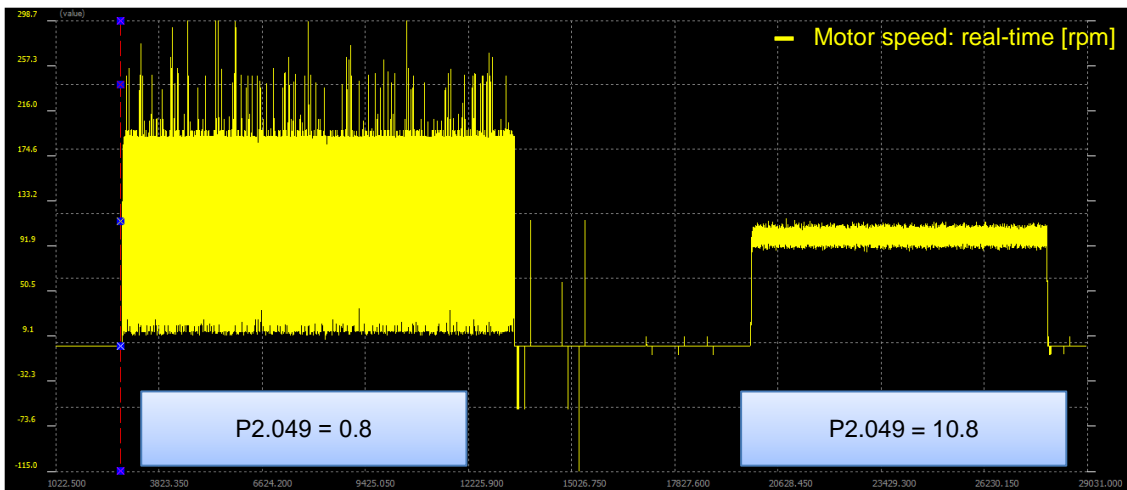

#### Relevant parameter

Refer to Chapter 8 for detailed descriptions of the relevant parameters.

Parameter	Function
P2.049	Speed detection filter and jitter suppression
P2.084	Special function for low resolution motor

## 5

## 5.7.4 Low-frequency vibration suppression filter

### 5.7.4.1 Function restriction

1. Set the control mode (P1.001.YX) to Position mode (PT or PR).
2. Frequency range: 1.0 Hz to 100.0 Hz.
3. If the low-frequency vibration suppression function and the vibration elimination function are enabled simultaneously, the system response becomes slower.

### 5.7.4.2 Function description

The low-frequency vibration suppression filter is also called position command notch filter. The low-frequency vibration suppression function filters the frequencies causing mechanical vibration but delays the system response time.

If the machine stiffness is insufficient, mechanical vibration persists even when the motor stops after the positioning command is complete. The low-frequency vibration suppression function can reduce the mechanical vibration. The suppression range is between 1.0 Hz and 100.0 Hz. The servo provides both manual and auto settings for the function of low-frequency vibration suppression. During the auto tuning process, the auto low-frequency vibration suppression function is enabled and properly set.

#### Auto setting:

If you have difficulty finding the frequency, enable the auto low-frequency vibration suppression function to automatically search for the vibration frequency.

If you set P1.029 to 1, the system automatically disables the auto low-frequency vibration suppression function (P1.026 and P1.028 are set to 0) and starts to search for the frequency which causes low-frequency vibration. When the detected frequency remains at the same level, the system automatically changes the settings in the following order.

1. Automatically resets P1.029 to 0.
2. Sets P1.025 as the first set of frequency and P1.026 to 1.
3. Sets P1.027 as the second set of frequency and P1.028 to 1.

When P1.029 is automatically reset to 0, but the low-frequency vibration persists, check if P1.026 or P1.028 is enabled automatically. If the values of P1.026 and P1.028 are both 0, it means no frequency is detected. Lower the value of P1.030 (Low-frequency vibration detection) and set P1.029 to 1 to search for the vibration frequency again. P1.030 sets the detection range for the peak-to-peak amplitude of low-frequency vibration. When the frequency is not detected, it is probably because the setting value of P1.030 is higher than the vibration of the machine. If so, it is suggested that you decrease the value of P1.030. Note that if the value is set too small, the system might mistakenly regard noise as the low-frequency vibration. In this case, you can use the Scope function of ASDA-Soft and set the channel to **Position error (pulse)** to observe the peak-to-peak amplitude of the signal during position for setting P1.030.

Flowchart of auto low-frequency vibration suppression:

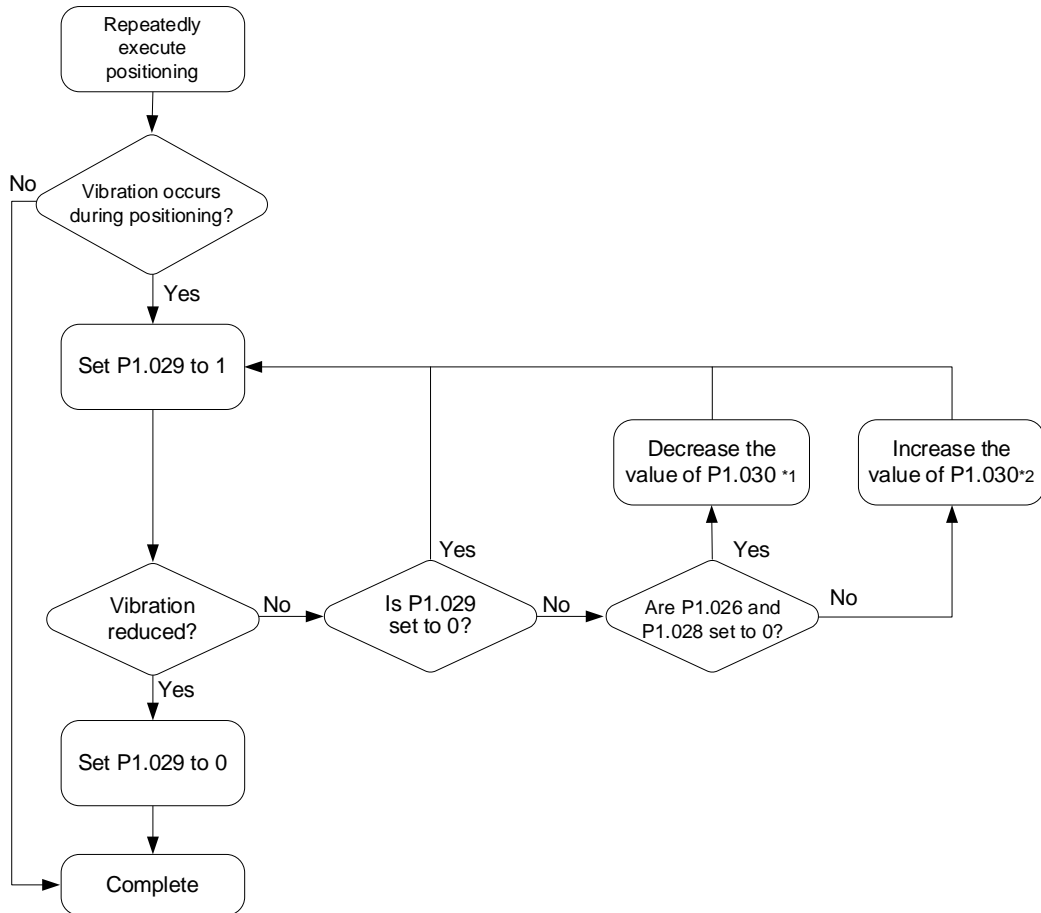

Note:

1. When the values of P1.026 and P1.028 are both 0, it means no frequency is detected. It is probably because P1.030 (Low-frequency vibration detection) is set too high so that the low-frequency vibration is not detected.
2. When the value of P1.026 or P1.028 is greater than 0, but the vibration persists, it is probably because P1.030 is set too low, causing the system to mistakenly regard minor frequency or noise as the low-frequency vibration.

### Manual setting:

When the auto suppression procedure is complete, but the vibration persists, you can manually set P1.025 or P1.027 to suppress the vibration if you have identified the vibration frequency.

There are two sets of low-frequency vibration suppression parameters: one is parameters P1.025 - P1.026 and the other is parameters P1.027 - P1.028. You can use these two sets of parameters to reduce two different low-frequency vibrations. Use P1.025 and P1.027 to set the frequencies for low-frequency vibration suppression. The filter function works only when the parameter setting is close to the actual vibration frequency. Use P1.026 and P1.028 to set the response after frequency filtering. The bigger the values of P1.026 and P1.028, the better the response. However, if you set the values too high, the motor might not operate smoothly. The default values of P1.026 and P1.028 are 0, which means the two filters are disabled by default.

5

5.7.4.3 Application example

During position settling, if a vibration with the frequency lower than 100 Hz (not the high-frequency noise when the motor is moving) occurs and it is difficult to identify the frequency with the System Analysis function, use the low-frequency vibration suppression function to suppress the vibration caused by the specific frequency. Setting the low-frequency vibration suppression filter makes the system more stable but lowers the response. When the frequency setting is the same for the two sets of low-frequency vibration suppression filter, the effect of vibration suppression is doubled.

If the frequency of the low-frequency vibration in the system varies during the operation, such as in the long-distance belt drive system, the vibration frequency may be different at two positioning points. In this case, set two sets of low-frequency vibration suppression individually.

<p>The graph plots Position on the y-axis and Time on the x-axis. A black line represents the 'Command position', which ramps down and then levels off. A red line represents the 'Feedback position', which follows the command but exhibits a low-frequency oscillation (vibration) around the settling point. A horizontal double-headed arrow labeled 'T' indicates the period of one full vibration cycle.</p>	<ol style="list-style-type: none"> <li>Set P1.025 and P1.026.  <math>P1.025 = 1/T</math>  <math>P1.026 = 1</math></li> </ol>
<p>The graph is similar to the first one, but the feedback position is shown in blue. The amplitude of the low-frequency vibration is smaller than in the first graph. The period of the vibration cycle is still labeled as 'T'.</p>	<ol style="list-style-type: none"> <li>If the vibration is smaller but not completely eliminated, you can set another set of low-frequency vibration suppression with the same frequency. The effect of vibration suppression is doubled.  <math>P1.027 = 1/T</math>  <math>P1.028 = 1</math></li> </ol>
<p>The graph shows the feedback position in blue. The low-frequency vibration has been completely eliminated, resulting in a smooth settling curve. The period 'T' is no longer indicated.</p>	<ol style="list-style-type: none"> <li>If the vibration is completely eliminated but the response is too slow, gradually increase P1.026.  <math>P1.026 = 2</math></li> </ol>

Relevant parameter

Refer to Chapter 8 for detailed descriptions of the relevant parameters.

Parameter	Function
P1.025	Low-frequency vibration suppression frequency 1
P1.026	Low-frequency vibration suppression gain 1
P1.027	Low-frequency vibration suppression frequency 2
P1.028	Low-frequency vibration suppression gain 2
P1.029	Auto low-frequency vibration suppression mode
P1.030	Low-frequency vibration detection

### 5.7.5 Model-controlled vibration suppression filter

The idea of model-following control is to build a virtual model of the real physical system in the servo drive in digital format. The virtual model processes the position command planned by the user and generates an optimized position command. At the same time, the model designs optimized position feed forward and speed feed forward, so the feedback system follows the optimized position command, achieving the expected response. If the response designed by the system does not meet your requirements, fine-tune the parameters P2.091 and P2.092.

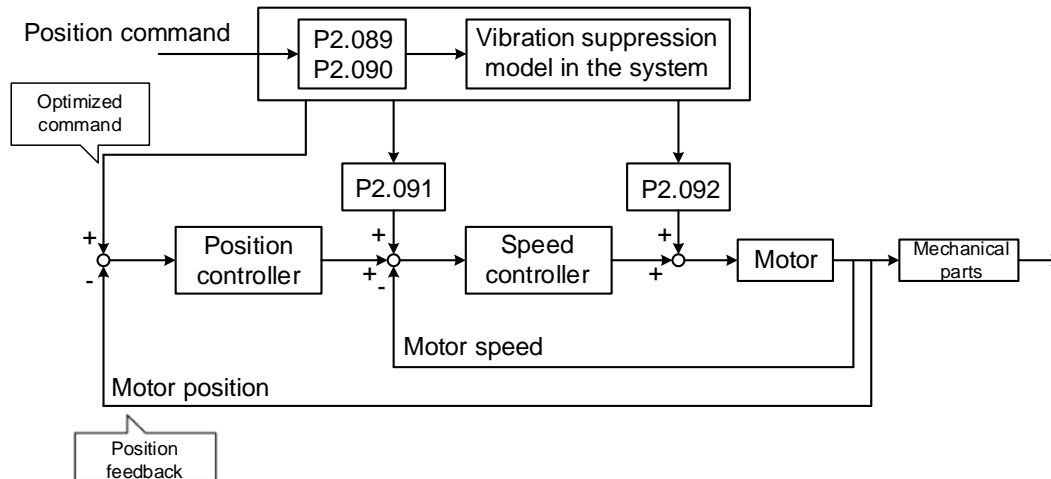

#### 5.7.5.1 Restrictions of the two degree of freedom control function

Setting P2.094 [Bit 12] to 1 enables the two degree of freedom control mode, but you need to note for the following restrictions.

1. Set the control mode (P1.001.YX) to Position mode (PT or PR).
2. Set the load inertia ratio or total weight (P1.037) correctly when using this function.
3. The setting of anti-interference gain (P2.026) is invalid when this function is used.



5

**5.7.5.2 Function description of two degree of freedom control function**

When the two degree of freedom control function is enabled (P2.094 [Bit 12] = 1), set P2.000 and P2.089 for better position response.

Set P2.089 to adjust how well the command response follows the command. Setting P2.089 higher can reduce the transient error between the position command and command response, but the error between the command response and feedback does not change. Thus, P2.089 is valid only when the position command changes. To reduce the difference between the command response and feedback, or to reduce the position jitter when the motor stops, adjust P2.000 or other control gain parameters.

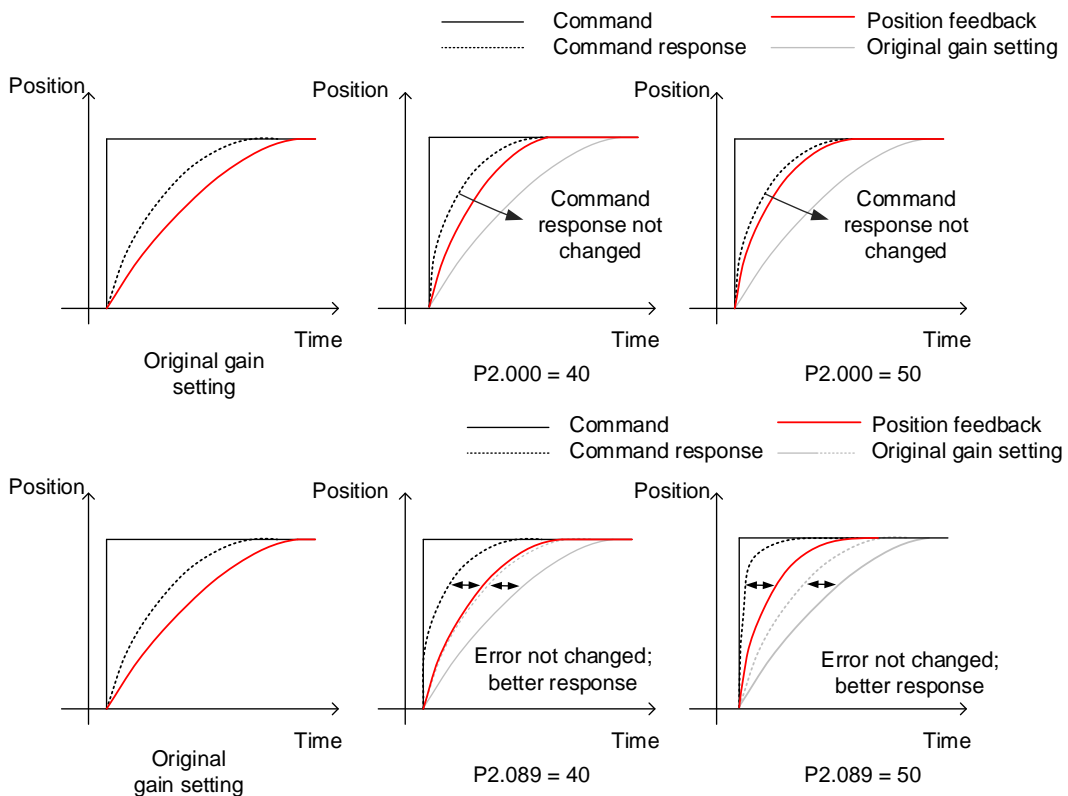

Setting P2.090 (Two degree of freedom mode - anti interference gain) can adjust the position settling waveform but does not change the command response time. Setting P2.090 to a smaller value lowers the response after the command is complete but reduces the position feedback overshoot.

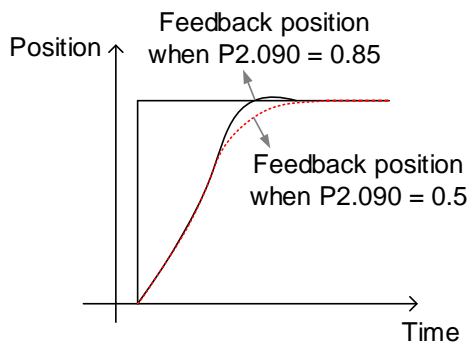

### 5.7.5.3 Application example of two degree of freedom control function

This section describes the parameter settings when the two degree of freedom control function is used in Manual Mode (P2.032 = 0). Refer to the following steps.

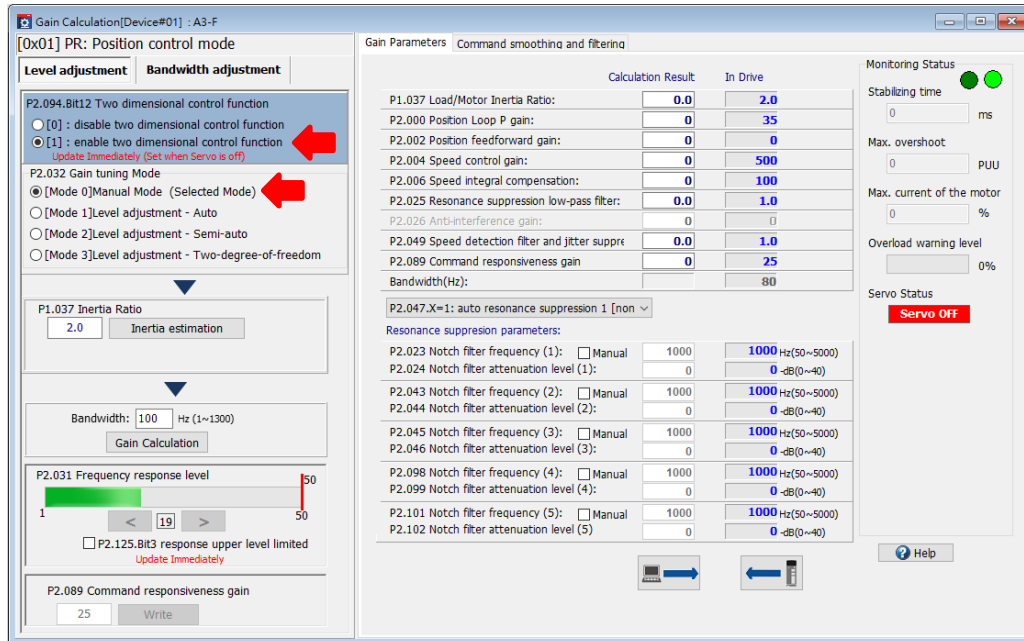

Switch the servo status to Servo ON and then start tuning. Change the parameter settings and at the same time use the Scope function to verify if the settings meet the requirements. It is advisable to increase the bandwidth gradually. To adjust the bandwidth significantly, enable the auto resonance suppression function (P2.047.X ≠ 0), set P2.047.Y and P2.047.Z to auto mode, and do not set the corresponding resonance parameters.

1. Increase the setting values of P2.000 and P2.089 while maintaining the ratio of P2.000 to P2.089 at approximately 1:1.
2. When the mechanical parts start to vibrate or generate high-frequency sounds, stop increasing P2.000 and decrease P2.000 until the mechanical parts are stable.
3. To increase the servo response, setting P2.089 higher to reduce the transient error of command response, but the position overshoot becomes greater. It is recommended that the setting value of P2.089 should be no more than two times the setting value of P2.000.
4. To fine-tune the positioning behavior, you can adjust P2.090.

#### Relevant parameter

Refer to Chapter 8 for detailed descriptions of the relevant parameters.

Parameter	Function
P2.000	Position control gain
P2.089	Command response gain
P2.090	Two degree of freedom mode - anti-interference gain
P2.091	Two degree of freedom mode - position feed forward gain
P2.092	Two degree of freedom mode - speed feed forward gain
P2.094	Special bit register 3 (enable the two degree of freedom control function)

### 5.7.5.4 Restrictions of vibration elimination

1. The two degree of freedom control function must be enabled (P2.094 [Bit 12] = 1).
2. Frequency range: 1.0 Hz to 400.0 Hz.
3. You can enable two sets of vibration elimination function simultaneously for A3-E and A3-F models, while you can enable only one set of vibration elimination function for A3-M and A3-L models.

### 5.7.5.5 Function description of vibration elimination

The vibration elimination function uses a special algorithm, which can eliminate the vibration in the machine endpoint without slowing down the system response. This function is automatically set during the One Touch Tuning process, or you can set this function in the System Analysis window of ASDA-Soft.

The vibration elimination function builds the flexible mechanical vibration model in the servo drive under the two degree of freedom control mode, so you need to enable the two degree of freedom control function before using the vibration elimination function. When the connection between mechanical parts is not rigid enough, the response between the motor endpoint and the machine endpoint is not consistent, resulting the condition where the motor has stopped but the machine endpoint still vibrates. As for this condition, you can use the System Analysis function in ASDA-Soft to provide optimal settings for the vibration elimination parameters, and set P2.097 [Bit 8] and [Bit 9] to enable one or two sets of the vibration elimination function. After the vibration elimination function is enabled, the servo adjusts the motor command according to the internal model. When you monitor the motor position feedback in the scope, there might be a jitter, but the machine endpoint is stable when settling.

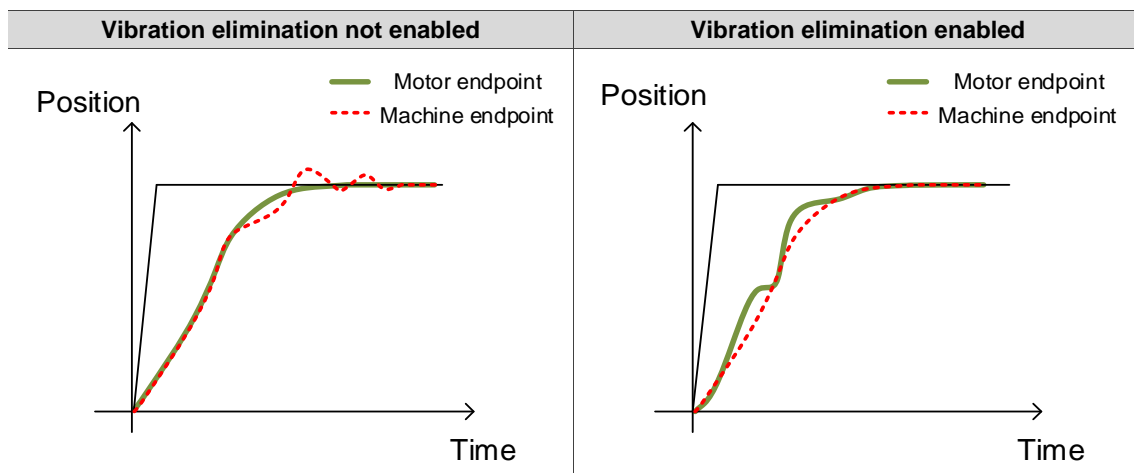

### 5.7.5.6 Application example of vibration elimination

1. Start ASDA-Soft and enter the **System Analysis** function window.
2. Select the check box for **Enable Low Frequency Analysis** and select **[2]: System Module** for the Analysis Type, and then click **Run** to start analyzing.
3. After the analysis is complete, go to the Vibration Elimination tab and click the radio button of **Enable** to enable the vibration elimination function. Then, click **Write to Servo** to complete the procedure.

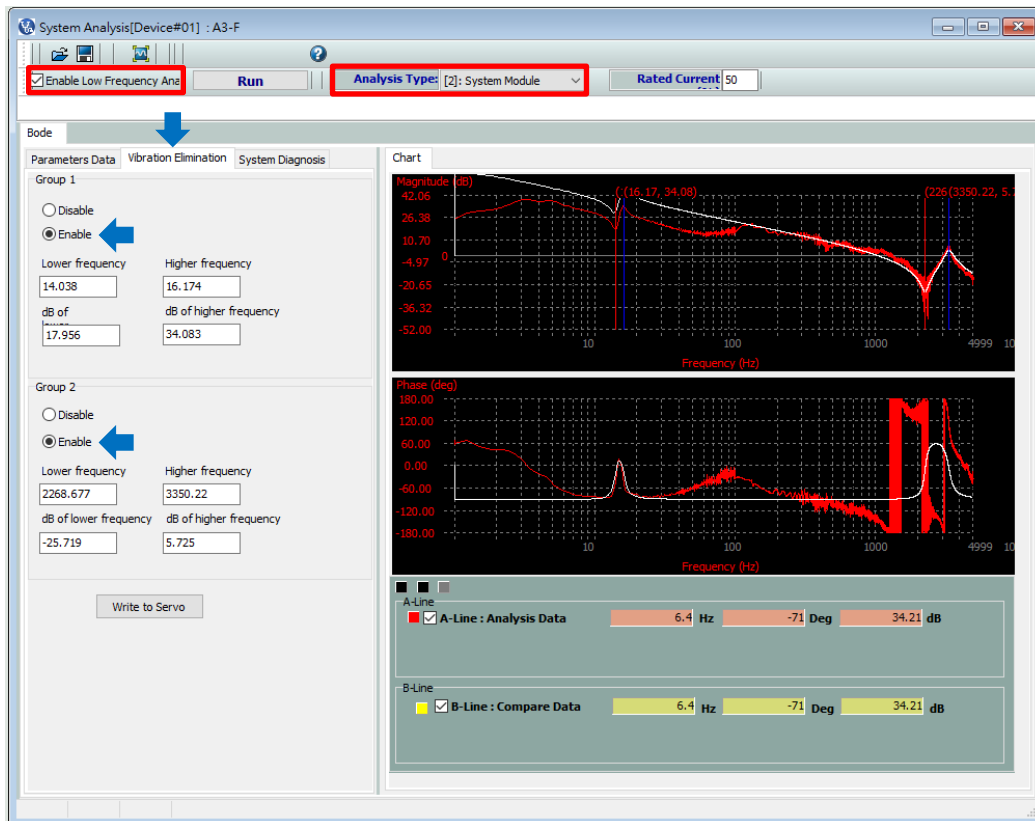

#### Relevant parameter

Refer to Chapter 8 for detailed descriptions of the relevant parameter.

Parameter	Function
P2.094	Special bit register 3 (enable the two degree of freedom control function)

5

**5.7.6 Position command filter**

**5.7.6.1 Function restriction**

Set the control mode (P1.001.YX) to Position mode (PT or PR).

**5.7.6.2 Function description**

If the position command changes too drastically, the speed command or current command may become saturated, causing the machine unable to operate according to the expected response. If the resolution of a pulse command is low, it may cause unexpected machine vibration. Adjusting the position command filter can improve the previous two conditions. It is advisable to use the position command filter with P1.008 and P1.068.

**Position command - smoothing constant (low-pass filter) (P1.008)**

After the position command is processed with the first-order low-pass filter, the unwanted high-frequency response or noise is attenuated, and the command becomes smoother.

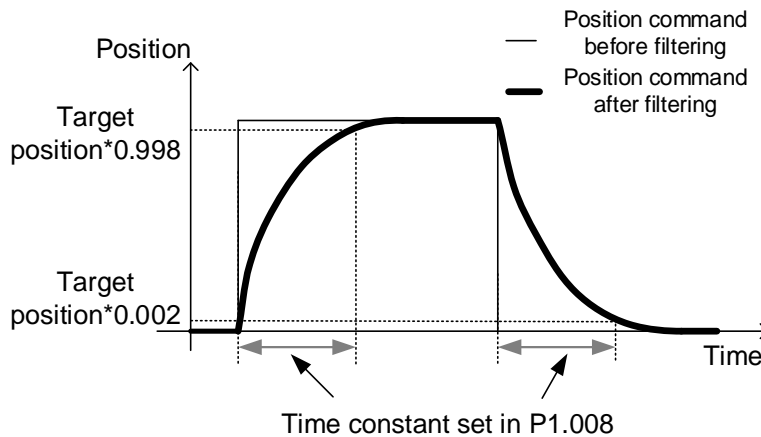

**Position command - moving filter (P1.068)**

This function distributes the position commands evenly within the set time. When the resolution of the position command is low, using the filter function of P1.068 is recommended. If you use P1.008, it will cause drastic speed changes.

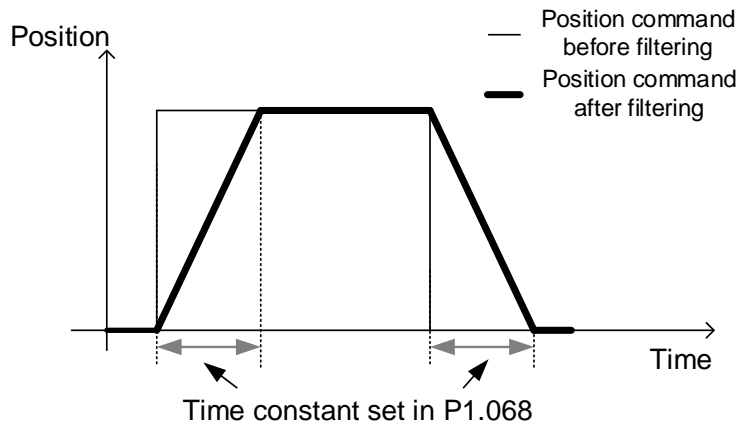

### 5.7.6.3 Application example

When the resolution of the position command is low (for example, the command resolution is lower than 10000 pulse/rev), using the position command filter reduces the jitter in the command feedback caused by low resolution.

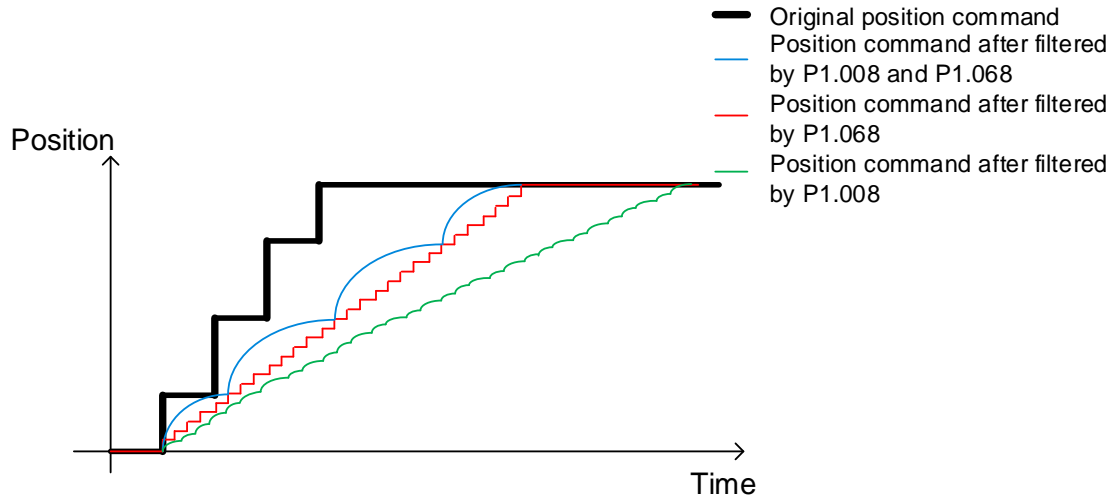

#### Relevant parameter

Refer to Chapter 8 for detailed descriptions of the relevant parameters.

Parameter	Function
P1.008	Position command - smoothing constant (low-pass filter)
P1.068	Position command - moving filter

5

5.7.7 Speed command filter

5.7.7.1 Function restriction

Set the control mode (P1.001.YX) to Speed mode (S or Sz).

5.7.7.2 Function description

After the speed command is processed with the first-order low-pass filter, the unwanted high-frequency response or noise is attenuated, and the command becomes smoother.

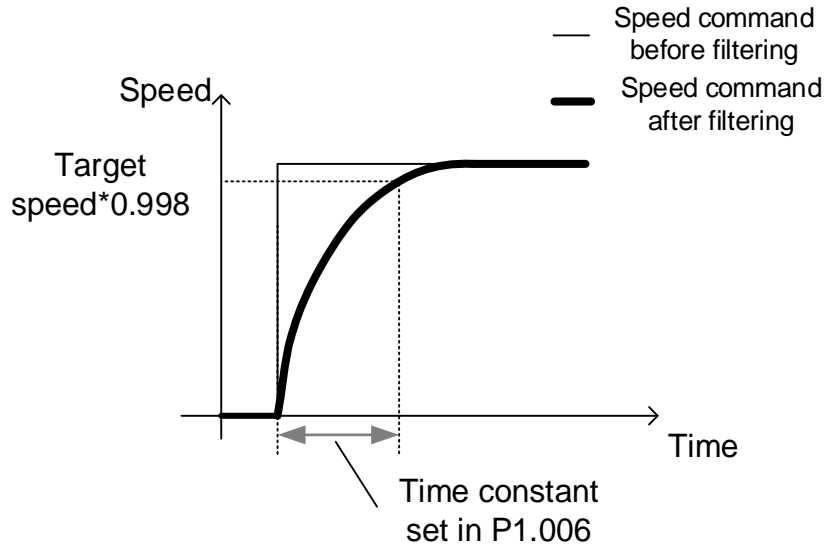

5.7.7.3 Application example

When the position control circuit of the machine is built in the controller, the servo is in analog Speed mode (S) and receives the external analog voltage speed command issued by the controller. To reduce the analog voltage noise, which can be detected by setting the channel to **Speed command: Voltage [Volt]** in the Scope function of ASDA-Soft, increase the setting value of P1.006. However, if the filter time is set too long, the position control response of the controller becomes slower. If desiring to keep the position control response stable, set the filter bandwidth 8 times (or more) the position bandwidth of the controller.

Relevant parameter

Refer to Chapter 8 for detailed descriptions of the relevant parameter.

Parameter	Function
P1.006	Speed command - smoothing constant (low-pass filter)

## 5.7.8 Torque command filter

### 5.7.8.1 Function restriction

Set the control mode (P1.001.YX) to Torque mode (T or Tz).

### 5.7.8.2 Function description

After the torque command is processed with the first-order low-pass filter, the unwanted high-frequency response or noise is attenuated, and the command becomes smoother.

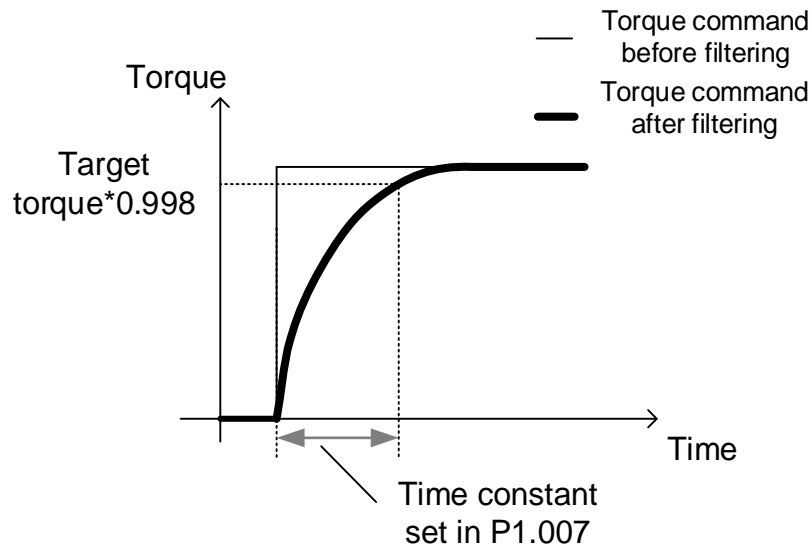

### 5.7.8.3 Application example

When the servo is in analog Torque mode (T) to perform force control (such as tension or pressure control), the command value is usually a constant which changes slowly. Since the bandwidth of the servo current loop is much higher than that of the position loop and speed loop, it is highly responsive but is subject to noise interference. Properly adjust P1.007 to reduce the high-frequency noise and increase the control accuracy.

#### Relevant parameter

Refer to Chapter 8 for detailed descriptions of the relevant parameter.

Parameter	Function
P1.007	Torque command - smoothing constant (low-pass filter)



5

## 5.8 Application function adjustment

### 5.8.1 Adjusting position error in constant speed zone

#### 5.8.1.1 Function restriction

1. When using P2.002 and P2.003, set P1.001.YX control mode to Position (PT, PR).
2. When using P2.007, you must set P1.001.YX control mode to Position or Speed (PT, PR, S, Sz).

#### 5.8.1.2 Function description

In Position mode, this function uses the Position command to calculate an ideal speed value and applies this value to the Speed command. This function reduces the position error in the constant speed zone during position control. Therefore, you can use this function to shorten the settling time or reduce the following error.

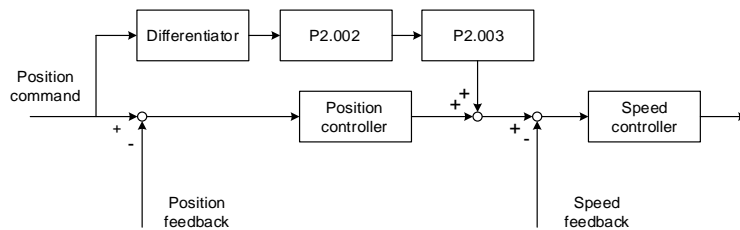

#### Position feed forward gain (P2.002)

This parameter converts the difference of the position command changes into an ideal speed value and applies this value to the Speed command. The higher the value of P2.002, the smaller the error in the constant speed zone, thus reducing the error when the system performs dynamic following. When this parameter is set to 100, it completely eliminates the position error at the constant speed zone but causes a greater position overshoot. When this parameter is set to 0, the position feed forward gain function is disabled.

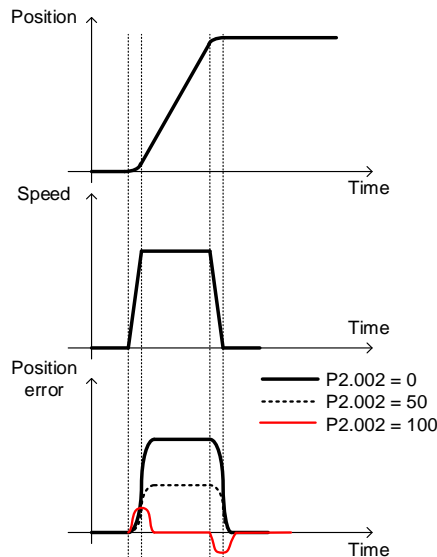

**Position feed forward gain smoothing constant (P2.003)**

The ideal speed is calculated by the position command with a differentiator, so the discontinued noise of the position command is also magnified. The lower the position command resolution, the more severe the noise. In this case, you can set a higher constant value to reduce the interference from the noise. Please note that the overshoot is greater during the position settling process if you set a higher value for the filter.

**Speed feed forward gain (P2.007)**

In Speed mode, this parameter calculates the ideal current using the speed command and applies this result to the electric current command. Using this function can reduce the speed error that occurs during uniform acceleration and deceleration. In Position mode, using this function is not recommended because it causes a rather poor settling performance.

**5.8.1.3 Application example**

In the application of contour control, to reduce the geometric error caused by the servo following error (i.e, the actual feedback radius is shorter than the command radius when circular path is executed), you can increase the setting of P2.002. In the point-to-point positioning application, you can also set a higher value for P2.002 to reduce the transient position error during acceleration. However, using the position feed forward gain function is more likely to cause position overshoot and a longer settling time.

**Note: do not use P2.002 (Position feed forward gain) for applications that do not allow overshoot, use P1.061 (Viscous friction compensation) instead.**

**Relevant parameter**

Refer to Chapter 8 for detailed descriptions.

Parameter	Function
P1.061	Viscous friction compensation
P1.062	Percentage of friction compensation
P1.063	Constant of friction compensation
P2.002	Position feed forward gain
P2.003	Position feed forward gain smoothing constant
P2.007	Speed feed forward gain

# 5

## 5.8.2 Position overshoot adjustment

### 5.8.2.1 Function restriction

When using this function, you must set P1.001.YX (control mode) to Position or Speed (PT, PR, S, or Sz).

### 5.8.2.2 Function description

The position overshoot occurred during positioning may be caused by the high value of P2.002 or a great change in the system friction. Lowering the setting of P2.002 or properly setting the viscous friction compensation can reduce the position overshoot.

When using the viscous friction compensation (P1.061), set the percentage of friction compensation (P1.062) to a non-zero value. Viscous friction compensation (P1.061) is the torque compensation amount in units of 0.1%/1000 rpm (rotary motor) or 0.1%/1000 mm/s (linear motor), which is based on the change of motor speed. When adjusting this parameter, first setting it to 100, 200, and gradually increasing the value is recommended. Setting the value too high may cause an increased overshoot or a longer settling time with an unchanged overshoot.

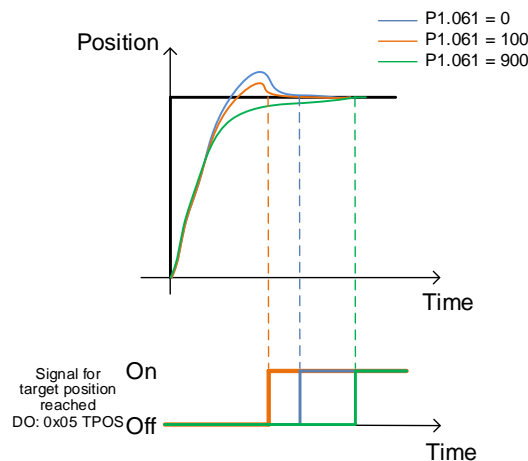

### 5.8.2.3 Application example

For the applications that do not allow overshoot, using this function can reduce the position overshoot; however, a high value of P1.061 can cause a longer positioning time.

#### Relevant parameter

Refer to Chapter 8 for detailed descriptions.

Parameter	Function
P1.061	Viscous friction compensation
P1.062	Percentage of friction compensation
P2.002	Position feed forward gain

### 5.8.3 Multi-axis contour control

#### 5.8.3.1 Function restriction

1. In the communication mode, settings for P1.034 - P1.036, P2.068, and P1.017 for each axis have to be consistent.
2. The two degree of freedom control function settings (P2.094 [Bit 12]) for each axis have to be consistent.
  - When the Two degree of freedom control function is enabled (P2.094 [Bit 12] = 1), settings of P2.002, P2.089, P1.008, and P1.068 for each axis must be consistent.
  - When the Two degree of freedom control function is disabled (P2.094 [Bit 12] = 0), settings of P2.000, P2.002, P1.008, and P1.068 for each axis must be consistent.
3. Setting the same speed loop bandwidth ( $P2.004 / 2\pi$ ) for each axis is recommended.

#### 5.8.3.2 Function description

For the application of multi-axis contour control, make sure the servo parameters among all axes are consistent. If the response settings among each axis do not match, the contour distorts.

1. When the filter parameter settings (P1.008, P1.068) of each axis are inconsistent, the response of the axis with a lower filter parameter setting goes ahead of the other axes.
2. When the position gain parameter settings (P2.000, P2.002, P2.089) of each axis are inconsistent, the response of the axis set with a higher position gain goes ahead of the other axes.
3. After all axes are tuned, if their speed loop bandwidth settings ( $P2.004 / 2\pi$ ) are not consistent but the contours remain undistorted, you can apply the position gain parameters of the axis with the lowest bandwidth to the other axes.

Note: it is recommended that you set the Analysis Type to **Speed Open-loop** in the System Analysis of ASDA-Soft; the zero-crossing frequency is the speed loop bandwidth.

5

The contours in black indicate that the response settings of each axis are consistent. The distorted contours in red and blue are generated due to the inconsistent response settings.

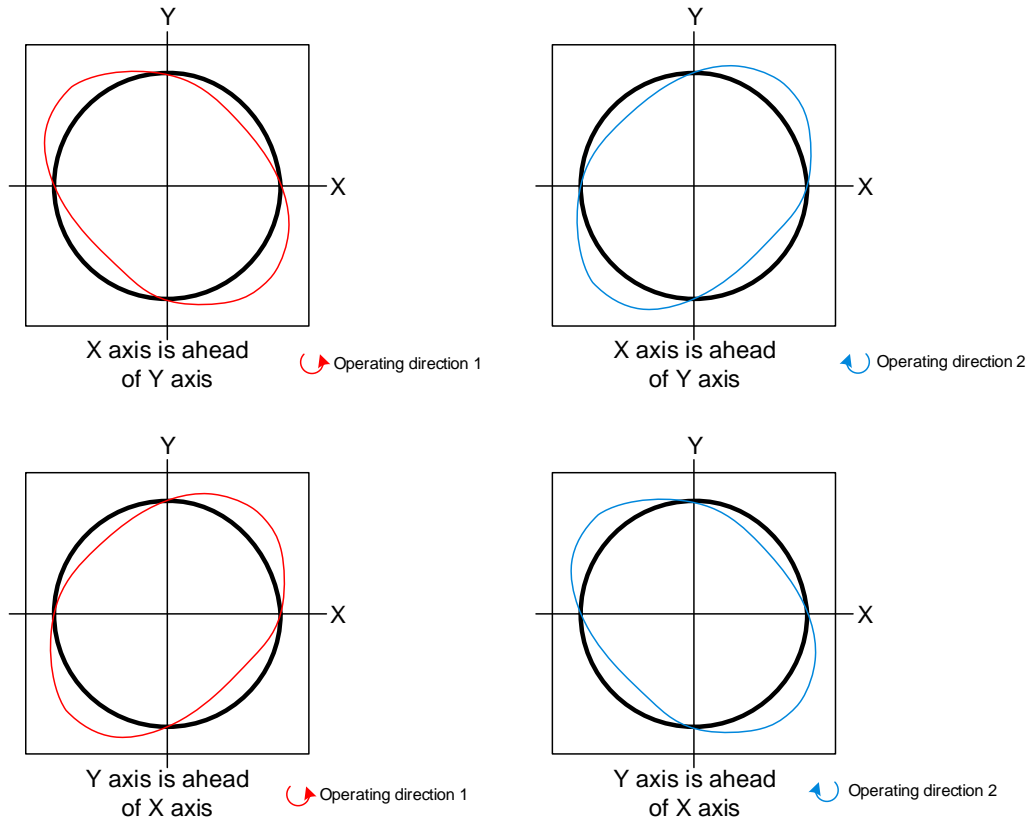

### 5.8.3.3 Application example

Adjusting the contour errors:

If the contour becomes unsmooth when transiting from one quadrant to another, it is caused by insufficient friction compensation of the servo. Descriptions for manually and automatically adjusting the friction compensation are as follows.

Manual adjustment:

Take the circular motion for example, you can gradually increase the value of P1.062 until the quadrant protrusion disappears and the quadrant becomes concave, and then start adjusting P1.063. On the basis of the default 100% of P1.063, the lower the value of P1.063, the sooner the system reaches the setting of P1.062; the higher the value of P1.063, the slower the system reaches the setting of P1.062. When the contour (error) upon quadrant transition slightly becomes concave, you can increase the setting of P1.063 to speed up the compensation. If the contour slightly becomes convex, reduce the setting of P1.063 to slow down the compensation.

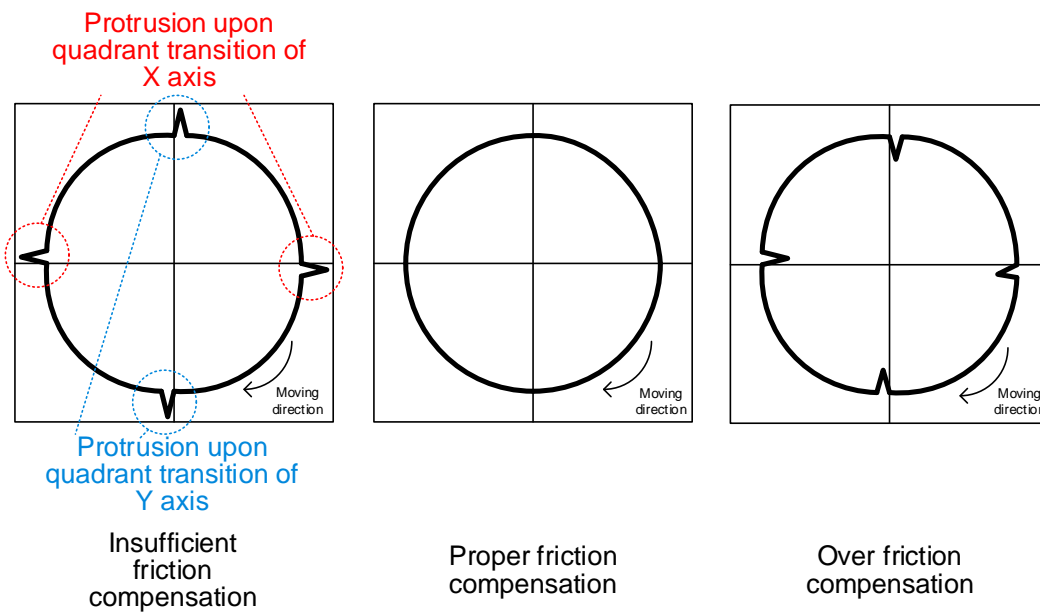

# 5

Auto adjustment:

The parameter for automatic friction estimation switch is P2.065 [Bit 4]. Set P2.065 [Bit 4] to 1 to enable the automatic friction estimation. Use the controller or PR command and set a continuous point-to-point motion (do not set the delay time) to keep the estimation performance. Once the estimation is complete, the servo automatically sets P2.065 [Bit 4] to 0.

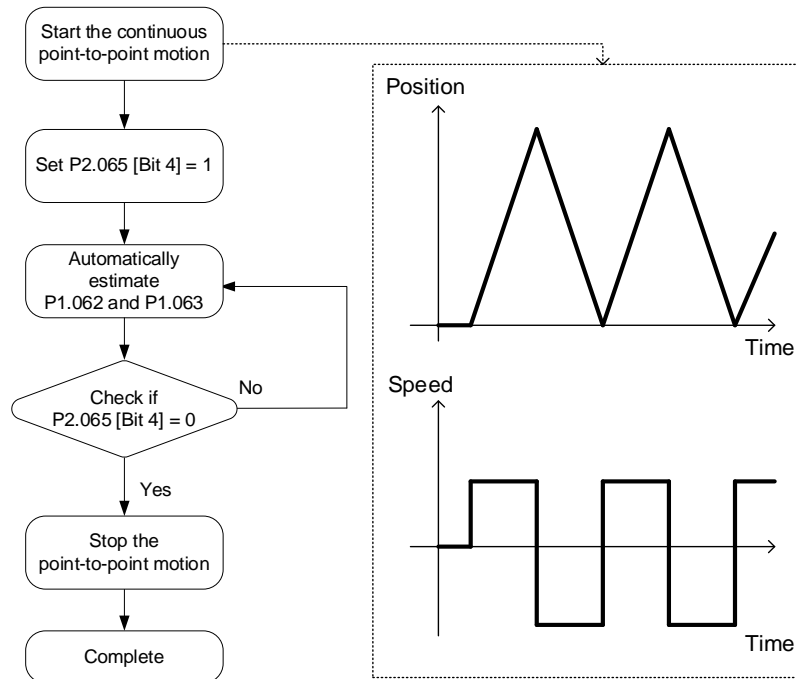

**Relevant parameter**

Refer to Chapter 8 for detailed descriptions.

Parameter	Function
P1.062	Percentage of friction compensation
P1.063	Constant of friction compensation
P2.065 [Bit 4]	Special bit register 1 (Automatic friction estimation)

## 5.8.4 Gain switching

### 5.8.4.1 Function restriction

1. When P2.027.X is set to 0, 1, 2, 4, 5, 6, or 8, P1.078 Gain switching delay time is not supported.
2. When P2.027.X is set to 3 or 7, P1.078 Gain switching delay time is supported.

### 5.8.4.2 Function description

Increasing the gain during operation can achieve a better command following and shorter settling time. Reducing the gain when the servo motor is in a stop state can reduce the high frequency noise and vibration.

During the gain switching process, if the servo motor operation is not smooth, increasing the gain switching time constant (P2.028) can smooth the gain switching process.

The servo automatically switches the relevant control parameters based on the value set for P2.027.X (Gain switching condition); however, you need to additionally set the change rate of the parameter (refer to the “After switching” columns in the following page).

### 5.8.4.3 Application example

The control mode and whether P1.078 is supported are determined by the gain switching conditions. Refer to the following descriptions.

P2.027.X: gain switching condition

X	Condition	Control mode	P1.078 Gain switching delay time
0	Disable gain switching function.	-	-
1	Signal of gain switching (DI.GAINUP: 0x03) is on.	All	-
2	In Position control mode, position error is larger than P2.029.	PT / PR	-
3	Frequency of Position command is larger than P2.029.	PT / PR	Supported
4	Speed of servo motor is faster than P2.029.	All	-
5	Signal of gain switching (DI.GAINUP: 0x03) is off.	All	-
6	In Position control mode, position error is smaller than P2.029.	PT / PR	-
7	Frequency of Position command is smaller than P2.029.	PT / PR	Supported
8	Speed of servo motor is slower than P2.029.	All	-



5

P2.027.Y: gain switching method

0: gain rate switching

1: integrator switching (switch from P controller to PI controller)

PT / PR			
Y = 0		Y = 1	
Before switching	After switching	Before switching	After switching
P2.000 x 100%	P2.000 x P2.001	P2.000 x 100%	P2.000 x P2.001
P2.004 x 100%	P2.004 x P2.005	P2.004 x 100%	P2.004 x 100%
P2.025 x 100%	P2.025 x P2.107	P2.025 x 100%	P2.025 x P2.107
P2.026 x 100%	P2.026 x 100%	P2.026 x 0%	P2.026 x 100%
P2.049 x 100%	P2.049 x P1.080	P2.049 x 100%	P2.049 x P1.080

S / Sz			
Y = 0		Y = 1	
Before switching	After switching	Before switching	After switching
P2.004 x 100%	P2.004 x P2.005	P2.004 x 100%	P2.004 x 100%
P2.025 x 100%	P2.025 x P2.107	P2.025 x 100%	P2.025 x P2.107
P2.026 x 100%	P2.026 x 100%	P2.026 x 0%	P2.026 x 100%
P2.049 x 100%	P2.049 x P1.080	P2.049 x 100%	P2.049 x P1.080

When P2.027.X is set to 0, 1, 2, 4, 5, 6, or 8, the gain switching delay time (P1.078) is not supported. P2.027.X = 4 is taken as the example in the following figure.

P2.027.X = 4

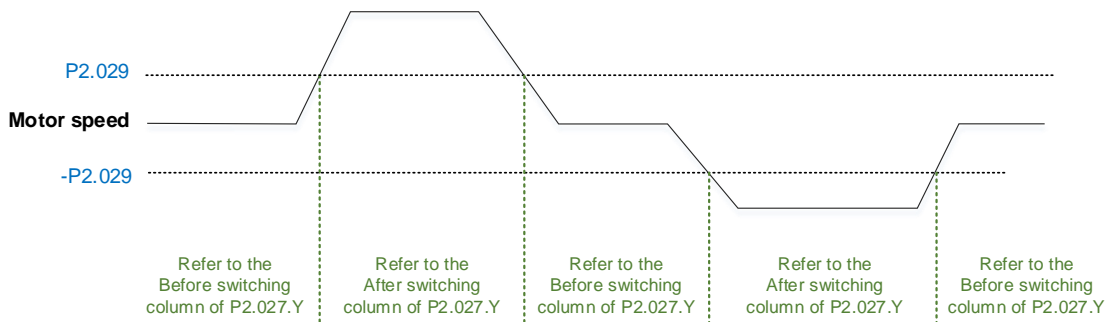

When P2.027.X is set to 3 or 7 and P1.078 Gain switching delay time is set, the gain parameter during the delay time is adjusted as follows.

**P2.027.X = 3**

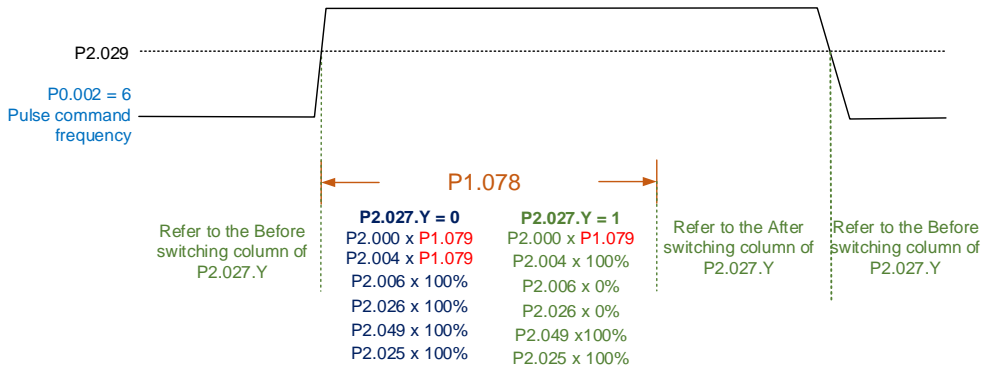

**P2.027.X = 7**

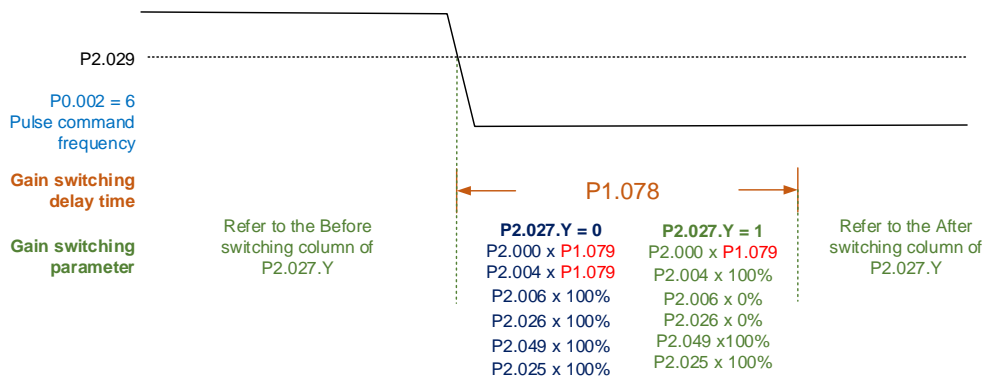

**Relevant parameter**

Refer to Chapter 8 for detailed descriptions.

Parameter	Function
P1.078	Gain switching delay time
P2.027	Gain switching condition and method selection
P2.028	Gain switching time constant
P2.029	Gain switching condition

(This page is intentionally left blank.)

5

# Control Mode

# 6

This chapter describes the operation of each control mode, including gain adjustment and filters. For Position mode, you use the external pulse and commands from the internal registers. For Speed mode and Torque mode, apart from the commands from the internal registers, you can also control the servo drive by the analog voltage input. In addition to the single modes, dual modes or multi-modes are also available for meeting the application requirements.

6.1	Selecting the control mode .....	6-3
6.2	Position mode.....	6-5
6.2.1	Position command in PT mode .....	6-5
6.2.2	Position command in PR mode.....	6-6
6.2.3	Control structure of Position mode.....	6-7
6.2.4	S-curve filter (Position) .....	6-8
6.2.5	Electronic gear ratio (E-Gear ratio) .....	6-10
6.2.6	Low-pass filter .....	6-11
6.2.7	Timing diagram of PR mode.....	6-11
6.2.8	Gain adjustment of the position loop .....	6-12
6.2.9	Low-frequency vibration suppression in Position mode .....	6-14
6.3	Speed mode.....	6-17
6.3.1	Selecting the Speed command source .....	6-17
6.3.2	Control structure of Speed mode.....	6-18
6.3.3	Smooth Speed command .....	6-19
6.3.4	Scaling of the analog command .....	6-21
6.3.5	Timing diagram of Speed mode .....	6-22
6.3.6	Gain adjustment of the speed loop .....	6-23
6.3.7	Resonance suppression unit.....	6-25
6.4	Torque mode .....	6-28
6.4.1	Selecting the Torque command source.....	6-28
6.4.2	Control structure of Torque mode .....	6-29
6.4.3	Smooth Torque command .....	6-29
6.4.4	Scaling of the analog command.....	6-30
6.4.5	Timing diagram of Torque mode.....	6-31
6.5	Dual mode / Multi-mode .....	6-32
6.5.1	Speed / Position dual mode .....	6-33
6.5.2	Speed / Torque dual mode.....	6-34

## 6

6.5.3	Torque / Position dual mode.....	6-35
6.6	Others.....	6-36
6.6.1	Applying the speed limit .....	6-36
6.6.2	Applying the torque limit.....	6-36
6.6.3	Analog monitoring.....	6-37
6.7	Full-closed loop control system.....	6-38
6.7.1	Hardware configuration.....	6-39
6.7.2	Control structure.....	6-41
6.7.3	Steps for setting the full-closed loop function .....	6-43
6.7.4	Parameters for full-closed loop function .....	6-44
6.7.4.1	Auxiliary encoder direction setting .....	6-44
6.7.4.2	Auxiliary encoder resolution setting .....	6-47
6.7.4.3	E-Gear settings.....	6-50
6.7.4.4	Setting the protection range for the feedback position error between the main encoder and auxiliary encoder .....	6-50
6.7.4.5	Setting the low-pass filter time constant for full- / semi-closed loop control.....	6-51
6.7.4.6	Setting the error clearing function when switching between full- and semi-closed loops.....	6-52
6.7.4.7	Auto clearing of the feedback position error between the main encoder and auxiliary encoder.....	6-55
6.7.4.8	Set DI [0x0B] to switch between full- and semi-closed loop modes ..	6-56
6.7.4.9	Z phase source of homing .....	6-57
6.7.4.10	Encoder output settings.....	6-58
6.7.4.11	Full-closed loop feedback source for the controller .....	6-60
6.7.5	Troubleshooting full-closed loop alarms.....	6-61

## 6.1 Selecting the control mode

This servo drive provides three basic control modes, Position, Speed, and Torque, and communication modes. For basic operations, you can choose from Single mode, Dual mode, and Multi-mode. The following table lists the available modes and corresponding descriptions.

Mode	Short name	Code	Description
Single mode	Position mode (Terminal block input)	PT	00 The servo drive receives the Position command and commands the motor to run to the target position. The Position commands are communicated through the terminal block and the signal type is pulse.
	Position mode (Internal register)	PR	01 The servo drive receives the Position command and commands the motor to run to the target position. The Position commands are issued from the internal registers (100 sets in total). Select the register number with DI signals or through communication.
	Speed mode	S	02 The servo drive receives the Speed command and commands the motor to run at the target speed. The Speed commands are issued from the internal registers (3 sets in total) or by analog voltage (-10V to +10V) which is communicated through the external terminal block. Select the command with DI signals.
	Speed mode (No analog input)	Sz	04 The servo drive receives the Speed command and commands the motor to run at the target speed. The Speed commands can only be issued from the internal registers (3 sets in total) instead of through the external terminal block. Select the command with DI signals.
	Torque mode	T	03 The servo drive receives the Torque command and commands the motor to run with the target torque. The Torque commands are issued from the internal registers (3 sets in total) or by analog voltage (-10V to +10V) which is communicated through the external terminal block. Select the command with DI signals.
	Torque mode (No analog input)	Tz	05 The servo drive receives the Torque command and commands the motor to run with the target torque. The Torque commands can only be issued from the internal registers (3 sets in total) instead of through the external terminal block. Select the command with DI signals.

## 6

Mode	Short name	Code	Description
Dual mode	PT-S	06	Switch PT and S modes with DI signals.
	PT-T	07	Switch PT and T modes with DI signals.
	PR-S	08	Switch PR and S modes with DI signals.
	PR-T	09	Switch PR and T modes with DI signals.
	S-T	0A	Switch S and T modes with DI signals.
	PT-PR	0D	Switch PT and PR modes with DI signals.
Communication	CANopen	0B	The dedicated communication mode for Delta's DVP-15MC series PLC controllers.
	DMCNET		DMCNET mode
	CANopen	0C	CANopen mode
	EtherCAT		EtherCAT mode
Multi-mode	PT-PR-S	0E	Switch PT, PR, and S modes with DI signals.
	PT-PR-T	0F	Switch PT, PR, and T modes with DI signals.
Second development platform mode	-	1x	In this mode, you can define the control mode by the program written in the EzASD software. Use the "MODE" instruction in EzASD to switch between the modes of IDLE, PATH, PT, USER, SPD, and TRQ.

Here are the steps to switch the control modes:

1. Switch the servo drive to Servo Off status. You can do this by setting DI.SON to off.
2. Set P1.001 by referring to the codes listed in the preceding table to set the control mode.
3. After setting the parameter, cycle power to the servo drive.

The following sections describe the operation of each mode, including the mode structure, command source and selection, command processing of the command, and gain adjustment.

## 6.2 Position mode

The servo drive provides two input modes for position control: external pulse (PT mode) and internal register (PR mode). In PT mode, the servo drive receives the pulse command for direction (motor runs forward or reverse). You can control the rotation angle of the motor with the input pulse. The servo drive can receive pulse commands of up to 4 Mpps.

You can also accomplish position control using the internal register (PR mode) without the external pulse command. The servo drive provides 100 command registers which you can set in two ways. Set the 100 registers first before switching the drive to Servo On status. Then, you can switch between commands with DI.POS0 - DI.POS6 of CN1 or directly set the register values through communication.

### 6.2.1 Position command in PT mode

The PT Position command is the pulse input from the terminal block. There are three pulse types and each type has positive and negative logic that you can set in P1.000. Refer to Chapter 8 for more details.

Parameter	Function
P1.000	External pulse input type



## 6.2.2 Position command in PR mode

The PR command source is the 100 built-in command registers, (P6.000, P6.001) - (P7.098, P7.099). You can use DI (0x11) - DI (0x13), DI (0x1A) - DI (0x1C), and (0x1E) (POS0 - POS6 of CN1) to select one of the 100 sets as the Position command and trigger the command with DI.CTRIG (0x08). See the following table for more details.

Position command	POS6	POS5	POS4	POS3	POS2	POS1	POS0	CTRIG	Corresponding parameter
Homing	0	0	0	0	0	0	0	↑	P6.000 P6.001
PR#1	0	0	0	0	0	0	1	↑	P6.002 P6.003
...									...
PR#50	0	1	1	0	0	1	0	↑	P6.098 P6.099
PR#51	0	1	1	0	0	1	1	↑	P7.000 P7.001
...									...
PR#99	1	1	0	0	0	1	1	↑	P7.098 P7.099

Status of POS0 - POS6: 0 means that DI is off (the circuit is open); 1 means that DI is on (the circuit is closed).

CTRIG↑: indicates the moment the DI is switched from off to on.

The absolute type and incremental type position registers are used to control the operation process. You can easily complete a periodic motor operation according to the preceding table. For example, assume the Position command PR#1 is 10 turns and PR#2 is 20 turns. PR#1 is issued first and PR#2 comes second. The following diagrams show the difference between absolute and incremental positioning.

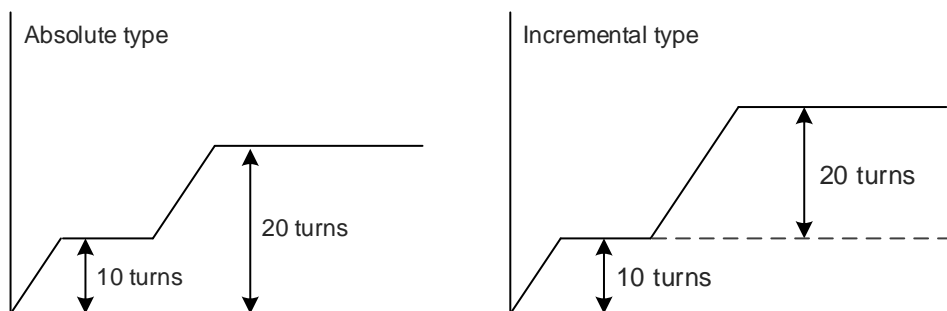

### 6.2.3 Control structure of Position mode

The following diagram shows the basic control structure of Position mode.

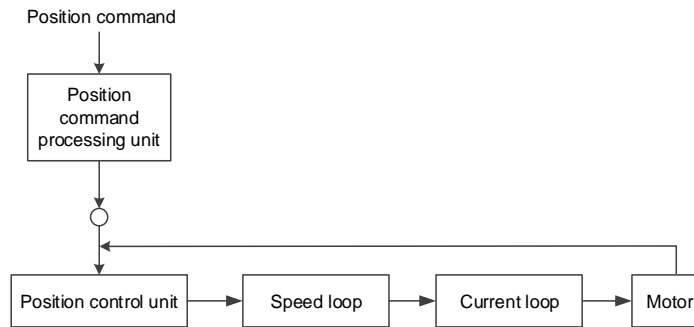

For better control, the pulse signals are processed by the Position command processing unit.

The structure is shown in the following diagram.

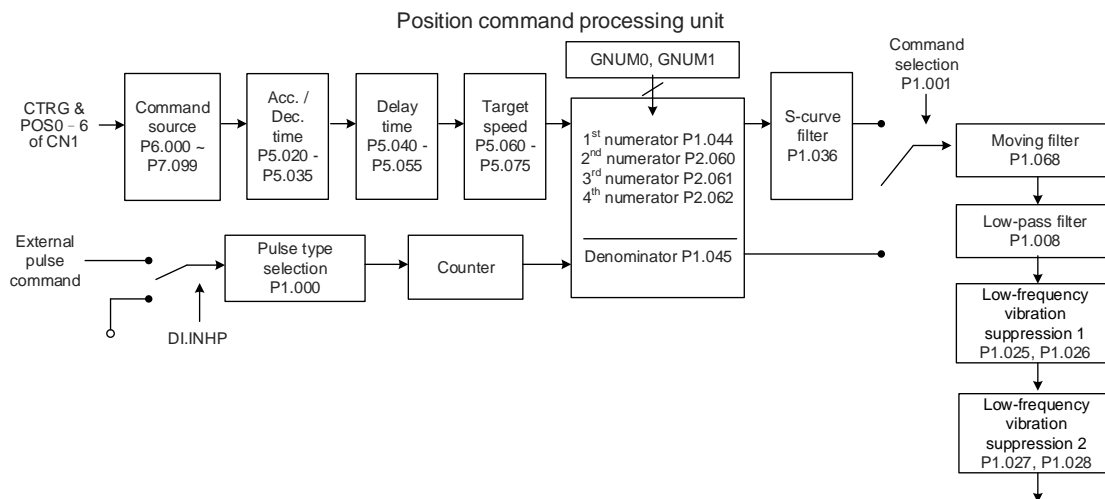

The upper path is the PR mode and the lower one is the PT mode, which you can select with P1.001. You can set the E-Gear ratio in both modes to adjust the positioning resolution.

In addition, you can use either a moving filter or a low-pass filter to smooth the command.

Refer to the next section for more details.

#### The Pulse Command Input Inhibit (INHP) function

In PT mode, when DI.INHP is on, the servo drive stops receiving external pulse commands and the motor stops running. As this function is only supported by P2.017 (DI8 functional planning), setting P2.017 to 0x45 (DI.INHP) is required.

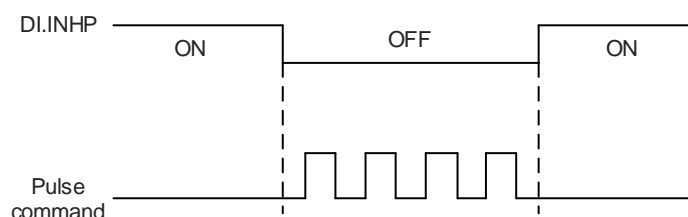

6

### 6.2.4 S-curve filter (Position)

The S-curve filter for Position commands smoothes the motion command in PR mode. The filter makes the speed and acceleration continuous and reduces jerking, resulting a smoother mechanical operation. If the load inertia increases, the motor operation is influenced by friction and inertia when the motor starts or stops rotating. Setting a larger acceleration / deceleration constant for the S-curve (P1.036) and the acceleration / deceleration time in P5.020 - P5.035 can increase the smoothness of operation.

When the Position command source is pulse, the speed and angular acceleration are continuous, so the S-curve filter is not necessary.

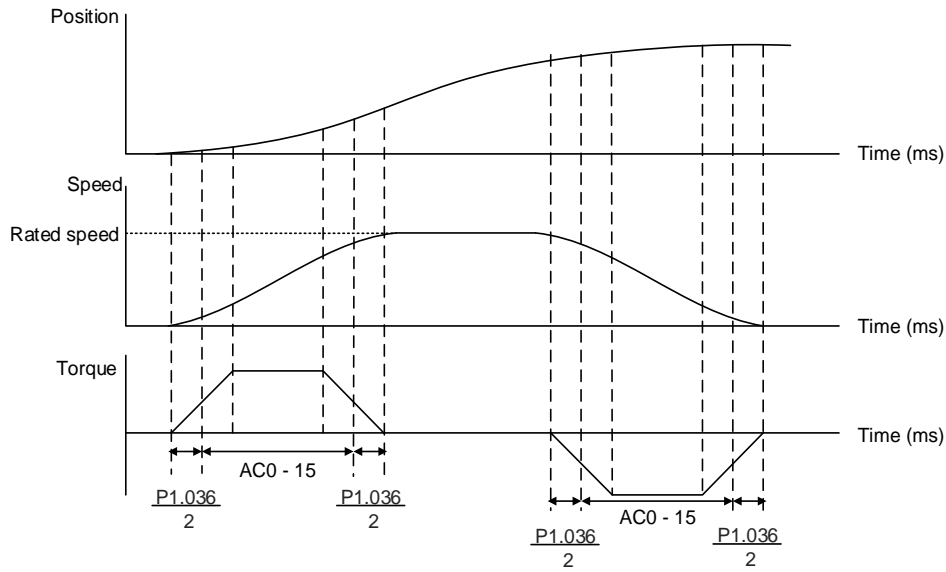

S-curve position and speed profiles and time setting (incremental position command)

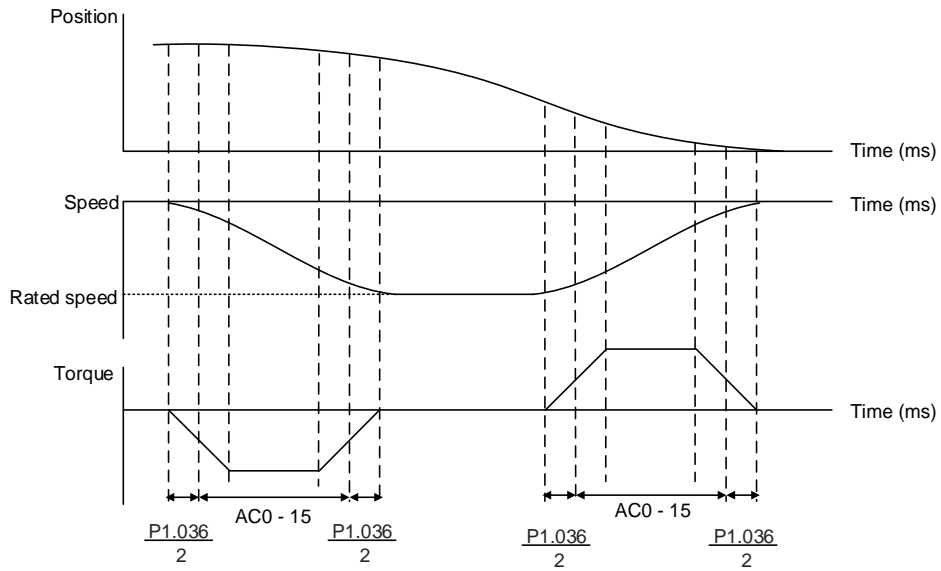

S-curve position and speed profiles and time setting (decremental position command)

Refer to Chapter 8 for detailed descriptions of the relevant parameters.

Parameter	Function
P1.036	S-curve acceleration / deceleration constant
P5.020 - P5.035	Acceleration / deceleration times (#0 - 15)

## 6

### 6.2.5 Electronic gear ratio (E-Gear ratio)

The electronic gear provides easy settings for the resolution. The resolution of the servo drive is 24-bit, which means the motor generates 16,777,216 pulses per revolution. Regardless of the encoder resolution (17-bit, 20-bit, or 22-bit), the E-Gear ratio is set according to the 24-bit resolution of the servo drive.

When the E-Gear ratio is 1, it generates 16,777,216 pulses per motor revolution; when you set the ratio to 0.5, then every two pulses from the command (controller) corresponds to one pulse for the motor. However, greater E-Gear ratio might create a sharp corner in the profile and lead to a high jerk. To solve this problem, you can apply an S-curve acceleration / deceleration filter or a low-pass filter.

For example, when you set the E-Gear ratio, the workpiece is moved at the speed of 1  $\mu\text{m}/\text{pulse}$ , meaning the workpiece moves 1  $\mu\text{m}$  per pulse.

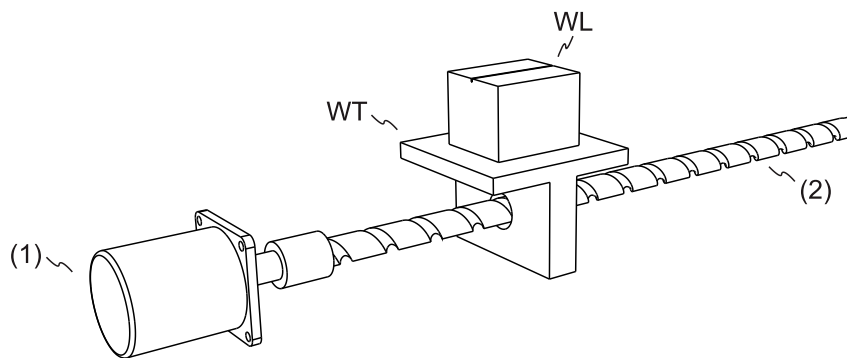

(1) Motor; (2) Ball screw pitch: 3 mm (equals 3000  $\mu\text{m}$ ); WL: workpiece; WT: platform

	Gear ratio	Moving distance per 1 pulse command
E-Gear is not applied	$= \frac{1}{1}$	$= \frac{3000 \frac{\mu\text{m}}{\text{rev}}}{16777216 \frac{\text{pulse}}{\text{rev}}} \times \frac{1}{1} = \frac{3000}{16777216}$ (Unit: $\frac{\mu\text{m}}{\text{pulse}}$ )
E-Gear is applied	$= \frac{16777216}{3000}$	$= \frac{3000 \frac{\mu\text{m}}{\text{rev}}}{16777216 \frac{\text{pulse}}{\text{rev}}} \times \frac{16777216}{3000} = 1$ (Unit: $\frac{\mu\text{m}}{\text{pulse}}$ )

Refer to Chapter 8 for detailed descriptions of the relevant parameters.

Parameter	Function
P1.044	E-Gear ratio - numerator N1
P1.045	E-Gear ratio - denominator M

### 6.2.6 Low-pass filter

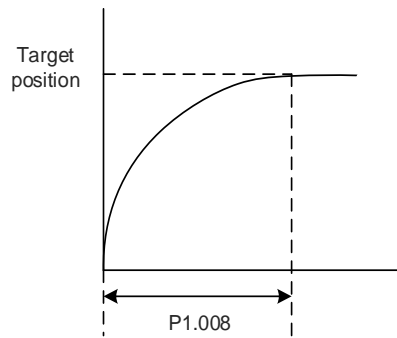

Refer to Chapter 8 for detailed descriptions of the relevant parameter.

Parameter	Function
P1.008	Position command - smoothing constant (low-pass filter)

### 6.2.7 Timing diagram of PR mode

In PR mode, the Position command is issued with the DI signals (POS0 - POS6 and CTRG) for CN1. Refer to Section 6.2.2 for information about the DI signal and the selected register.

The timing diagrams are shown as follows.

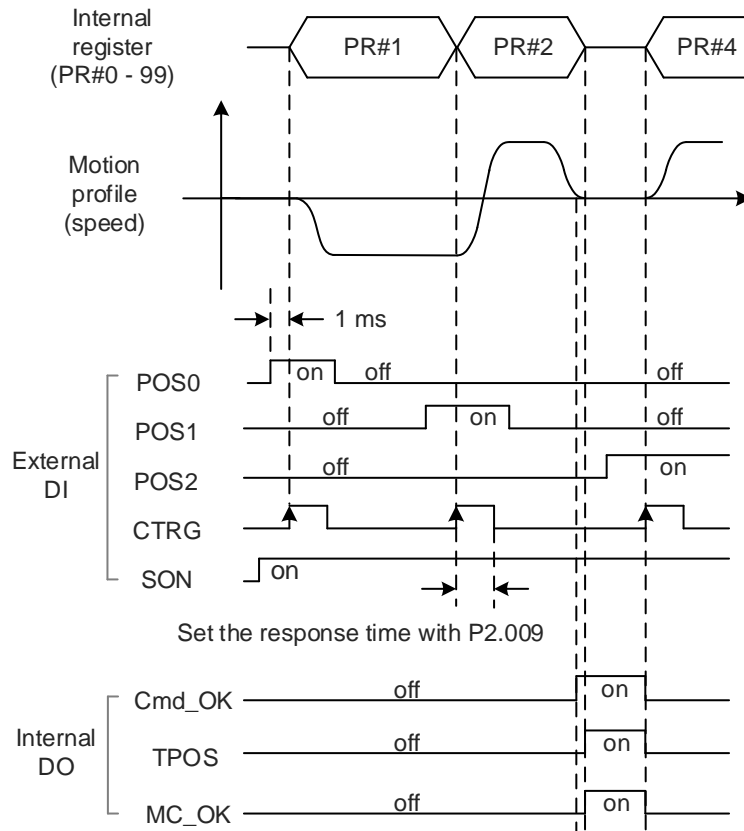

Note: Cmd\_OK is on when the PR command is complete; TPOS is on when the error is smaller than the value set by P1.054; MC\_OK is on when Cmd\_OK and TPOS are both on.

## 6

### 6.2.8 Gain adjustment of the position loop

There are two types of gain adjustment for the position loop: auto and manual.

- Auto adjustment

The servo drive can complete the gain adjustment with the Auto Tuning function. Refer to Chapter 5 Tuning for a detailed description.

- Manual adjustment

Before setting the position control unit, you have to set the speed control unit manually with P2.004 and P2.006 since a speed loop is included in the position loop. Then set the position control gain (P2.000) and position feed forward gain (P2.002).

Description of the position control gain and position feed forward gain:

1. Position control gain: the higher the gain, the larger bandwidth for the position loop response.
2. Position feed forward gain: reduces the deviation of phase delay.

Note that the position loop bandwidth should not be larger than the speed loop bandwidth.

Calculation:  $f_p \leq \frac{f_v}{4}$  ( $f_v$ : response bandwidth (Hz) of speed loop;

$f_p$ : response bandwidth (Hz) of position loop)

$$KPP = 2 \times \pi \times f_p$$

Example: if the desired position bandwidth is 20 Hz, adjust KPP (P2.000) to 125. ( $2 \times \pi \times 20 \text{ Hz} = 125$ ).

Refer to Chapter 8 for detailed descriptions of the relevant parameters.

Parameter	Function
P2.000	Position control gain
P2.002	Position feed forward gain

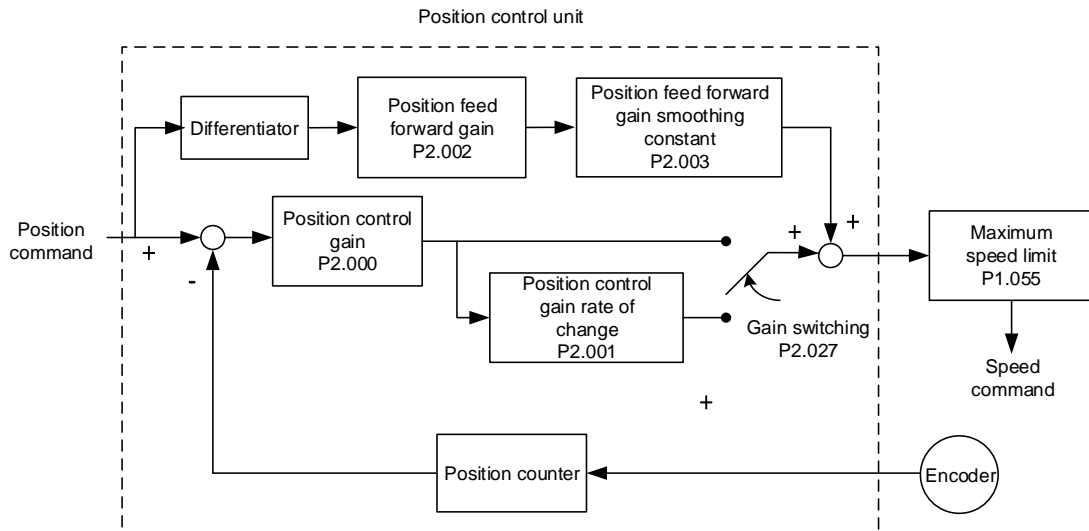

When you set the value of KPP (P2.000) too high, the bandwidth for the position loop is increased and the phase margin is reduced. Meanwhile, the rotor rotates and vibrates in the forward and reverse directions. Then, you have to decrease the KPP value until the rotor stops vibrating. When the external torque is too high, the low value of KPP cannot meet the demand of reducing the position following error. In this case, increasing the position feed forward gain, PFG (P2.002), can effectively reduce the following error.

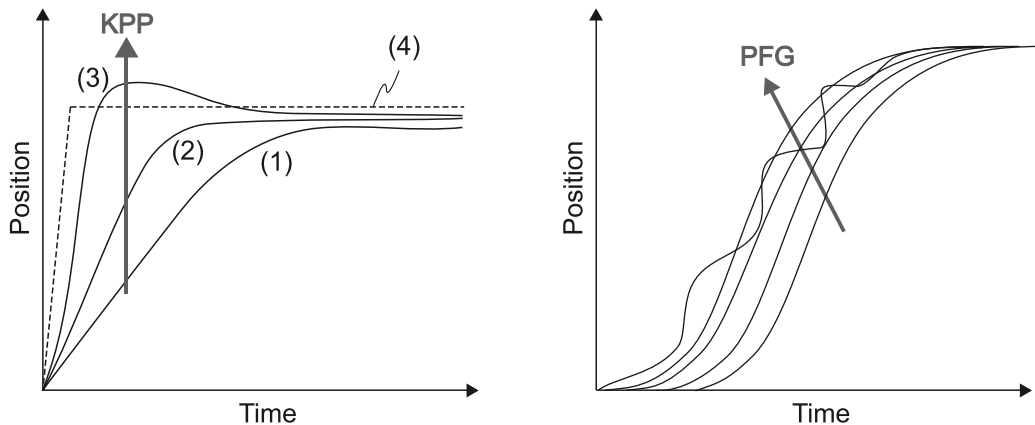

The actual position profile changes from (1) to (3) with the increase in the KPP value. (4) stands for the Position command.



## 6

### 6.2.9 Low-frequency vibration suppression in Position mode

If the machine is too flexible, vibration persists even when the motor stops after the positioning command is complete. The low-frequency vibration suppression function can reduce the machine vibration. The suppression range is between 1.0 Hz and 100.0 Hz. You can use this function with either auto or manual setting.

#### Auto settings

If you have difficulty finding the frequency, you can enable the auto low-frequency vibration suppression function, which automatically searches for the vibration frequency.

When you set P1.029 to 1, the system disables the auto low-frequency vibration suppression function automatically (by setting P1.026 and P1.028 to 0) and starts to search for the vibration frequency. When the detected frequency remains at the same level, the system automatically changes the settings as follows.

1. Sets P1.029 to 0.
2. Sets P1.025 to the first frequency and sets P1.026 to 1.
3. Sets P1.027 to the second frequency and sets P1.028 to 1.

When P1.029 is automatically reset to 0, but the low-frequency vibration persists, check if P1.026 or P1.028 is set to 1. If either P1.026 or P1.028 is 1, increase the setting of P1.030 (Low-frequency vibration detection). If the values of P1.026 and P1.028 are both 0, it means no frequency is detected. In this case, lower the value of P1.030 and set P1.029 to 1 to search for the vibration frequency again. Note that when you set the detection level too low, noise might be detected as low-frequency vibration.

The process of automatically searching for the vibration frequency is shown in the following flowchart.

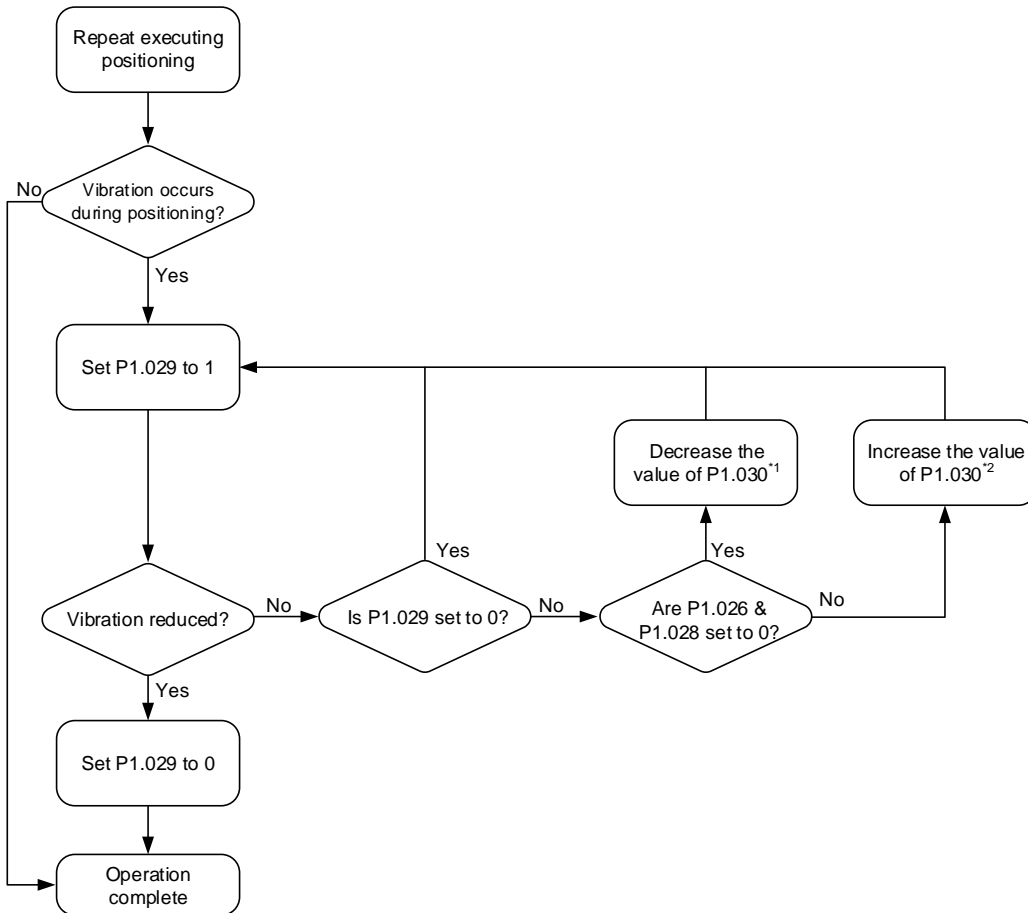

Note:

1. When the values of P1.026 and P1.028 are both 0, it means that the frequency cannot be found, probably because the detection level is set too high so that the low-frequency vibration is not detected.
2. When the value of P1.026 or P1.028 is greater than 0 and the vibration is not reduced, it is probably because the detection level is set too low, and the system detects noise or other frequency as low-frequency vibration.
3. When the auto suppression procedure completes, but the vibration persists, you can manually set P1.025 or P1.027 to suppress the vibration if you have identified the low frequency.

Refer to Chapter 8 for detailed descriptions of the relevant parameters.

Parameter	Function
P1.029	Auto low-frequency vibration suppression mode
P1.030	Low-frequency vibration detection

P1.030 sets the detection range for the peak-to-peak amplitude of low-frequency vibration. When the frequency is not detected, it is probably because the value of P1.030 is set too high and it exceeds the vibration range. If so, it is suggested that you decrease the value of P1.030. Note that if the value is set too small, the system might detect noise as the low-frequency vibration. In this case, you can use the Scope function of ASDA-Soft and set the channel to

“Position error (pulse)” to observe the peak-to-peak amplitude of the signal during positioning for setting P1.030.

# 6

## Manual settings

There are two sets of low-frequency vibration suppression parameters: one is parameters P1.025 - P1.026 and the other is parameters P1.027 - P1.028. You can use these two sets of parameters to reduce two different low-frequency vibrations. Use P1.025 and P1.027 to set the frequencies when the low-frequency vibrations occur. The suppression function works only when the set frequency is close to the real vibration frequency. Use P1.026 and P1.028 to set the response after frequency filtering. The greater the values of P1.026 and P1.028, the better the response. However, if you set the values too high, the motor might not operate smoothly. The default values of P1.026 and P1.028 are 0, which means the two filters are disabled by default.

Refer to Chapter 8 for detailed descriptions of the relevant parameters.

Parameter	Function
P1.025	Low-frequency vibration suppression frequency 1
P1.026	Low-frequency vibration suppression gain 1
P1.027	Low-frequency vibration suppression frequency 2
P1.028	Low-frequency vibration suppression gain 2

## 6.3 Speed mode

There are two kinds of command sources: analog input and internal register (parameters). The analog command controls the motor speed by scaled external voltage input. The command register input controls the speed in two ways. Set different speed values in three command registers before operation. Then, you can switch the speed settings through communication or with DI.SPD0 and DI.SPD1 of CN1. To deal with the problem of non-continuous speed when switching registers, you can use the S-curve acceleration and deceleration filter. In a closed-loop system, the servo drive uses gain adjustment (Manual mode or 5 gain adjustment modes) and the integrated PI controller.

In Manual mode, you can set all the parameters, so all the auto or auxiliary functions are disabled. In gain adjustment modes, the servo drive performs estimation of the load inertia and allows you to tune the bandwidth as well as the responsiveness. In this case, the parameter values you set are regarded as the default values.

### 6.3.1 Selecting the Speed command source

There are two types of Speed command sources: analog voltage and internal register (parameters). Select the command source with DI signals of CN1. See the following table for more details.

Speed command number	DI signal of CN1		Command source		Content	Range	
	SPD1	SPD0	Mode				
S1	0	0	Mode	S	External analog signal	Voltage difference between V_REF and GND	-10V to +10V
				Sz	N/A	Speed command is 0	0
S2	0	1	Internal register parameter		P1.009	-75000 to +75000	
S3	1	0			P1.010	-75000 to +75000	
S4	1	1			P1.011	-75000 to +75000	

- Status of SPD0 - SPD1: 0 means that DI is off (the circuit is open); 1 means that DI is on (the circuit is closed).
- When both SPD0 and SPD1 are 0, if the drive is in Sz mode, the command is 0. Thus, if the Speed command using analog voltage is not required, you can use Sz mode to avoid zero voltage drift. If the drive is in S mode, the command is the voltage difference between V\_REF and GND. The range of the input voltage is between -10V and +10V, and you can adjust the corresponding speed with P1.040.
- When either one of SPD0 and SPD1 is not 0, the Speed command comes from the internal register. The command is activated once the statuses of SPD0 and SPD1 are switched. There is no need to use DI.CTRG for triggering.

- The parameter setting range (internal register) is -75000 to +75000.  
Rotation speed = setting value x unit (0.1 rpm). For example, if P1.009 = +30000,  
then rotation speed = +30000 x 0.1 rpm = +3000 rpm

## 6

You can use the Speed command in Speed mode (S or Sz) as well as in Torque mode (T or Tz) to set the speed limit.

### 6.3.2 Control structure of Speed mode

The following diagram shows the basic control structure of Speed mode.

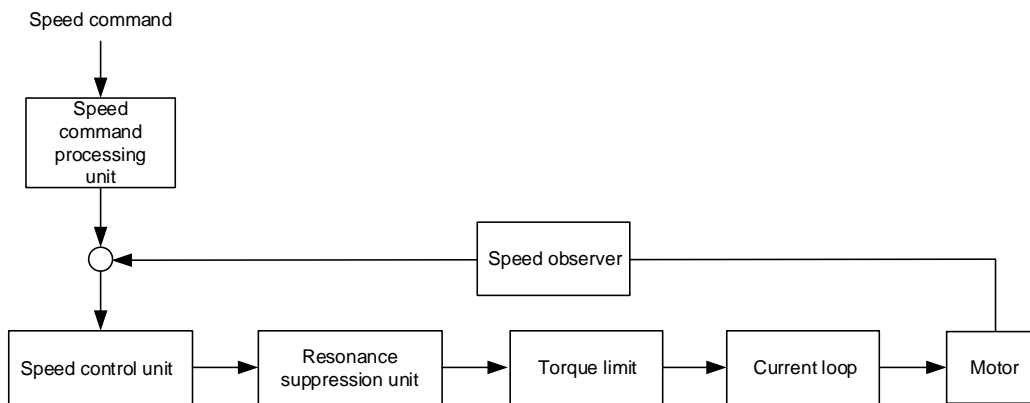

The Speed command processing unit selects the command source (see Section 6.3.1), including the scaling parameter (P1.040) for rotation speed and S-curve parameter for smoothing the speed. The Speed control unit controls the gain parameters of the servo drive and calculates the current command for the servo motor in real-time. The Resonance suppression unit suppresses the resonance of the machine.

The structure of the Speed command processing unit is shown in the following diagram.

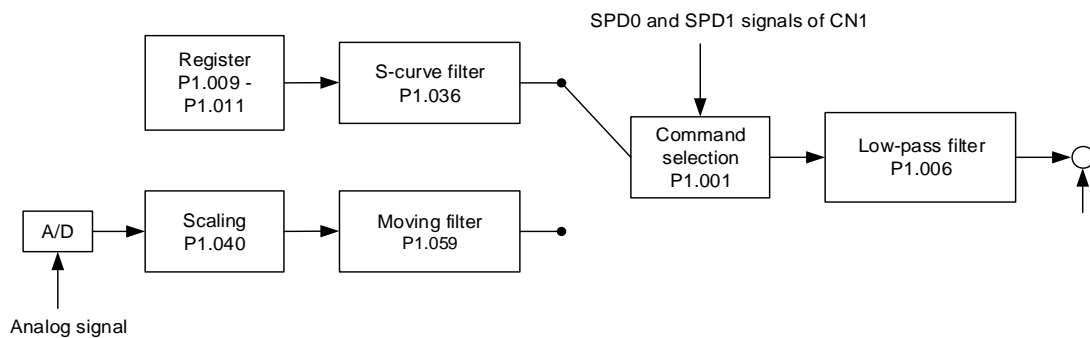

The upper path is the command from the register and the lower one is the command from the external analog voltage, which you can select with the status of SPD0 and SPD1, and P1.001 (S or Sz). In this condition, the S-curve and low-pass filters are applied to achieve a smoother response.

### 6.3.3 Smooth Speed command

#### S-curve filter

During the process of acceleration or deceleration, the S-curve filter uses the three-stage acceleration curve and creates a smoother motion profile. It avoids jerk (rapid change of acceleration), resonance, and noise caused by abrupt speed variation. You can use the following parameters for adjustment.

- The S-curve acceleration constant (P1.034) adjusts the slope of the change in acceleration.
- The S-curve deceleration constant (P1.035) adjusts the slope of the change in deceleration.
- The S-curve acceleration / deceleration constant (P1.036) improves the stability of the motor when it starts and stops.

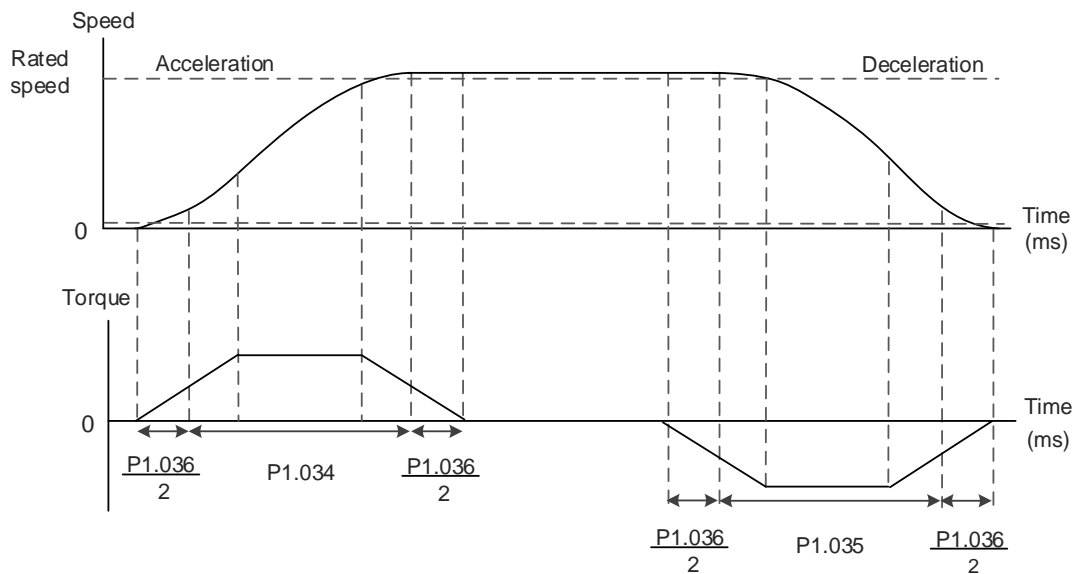

Figure 6.3.3.1 S-curve speed profile and time setting

Refer to Chapter 8 for detailed descriptions of the relevant parameters.

Parameter	Function
P1.034	S-curve acceleration constant
P1.035	S-curve deceleration constant
P1.036	S-curve acceleration / deceleration constant

6

**S-curve filter for analog commands**

The Analog Speed command filter helps to stabilize the motor operation when the analog input signal (speed) changes rapidly.

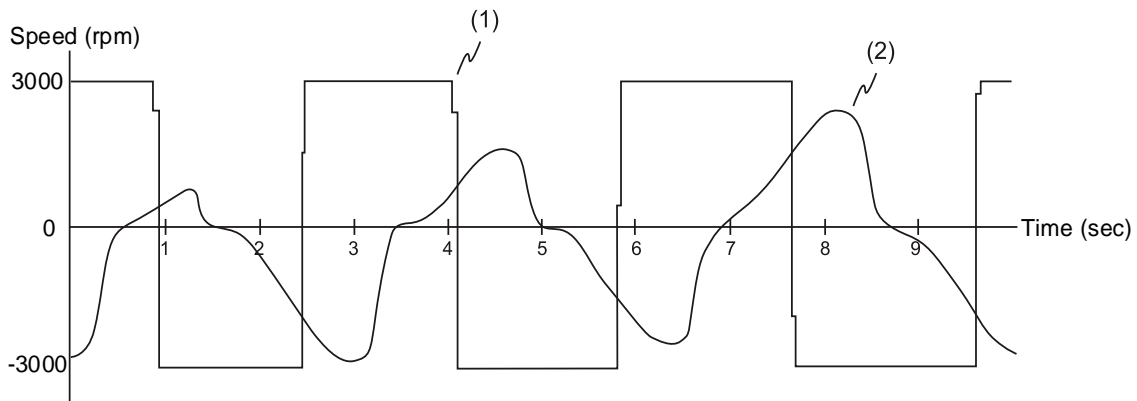

(1) Analog Speed command; (2) Motor speed

The Analog Speed command filter smooths the analog input signal. Its time program is the same as that of the S-curve filter for normal speed command. Also, the speed and acceleration curves are both continuous. The preceding diagram shows the curve of the Speed command and the motor speed when you apply the Analog Speed command filter. The slopes of the Speed command in acceleration / deceleration are different. You can adjust the time setting (P1.034, P1.035, and P1.036) according to the actual application to improve the performance.

**Low-pass filter for speed commands**

You usually use the low-pass filter to remove unwanted high-frequency response or noise so that the speed change is smoother.

Refer to Chapter 8 for detailed descriptions of the relevant parameter.

Parameter	Function
P1.006	Speed command - smoothing constant (low-pass filter)

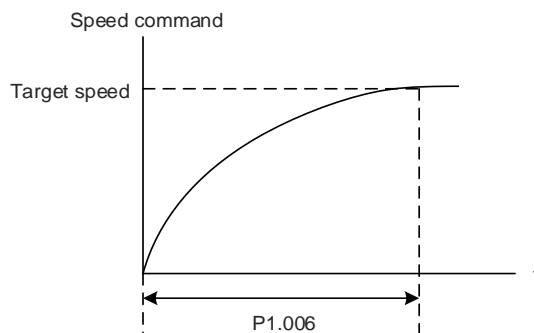

### 6.3.4 Scaling of the analog command

The Speed command is controlled by the analog voltage difference between V\_REF and GND. Use P1.040 and P1.081 to adjust the slope of the speed and its range. Moreover, you can use P1.082 to modify the filter switching time between P1.040 and P1.081.

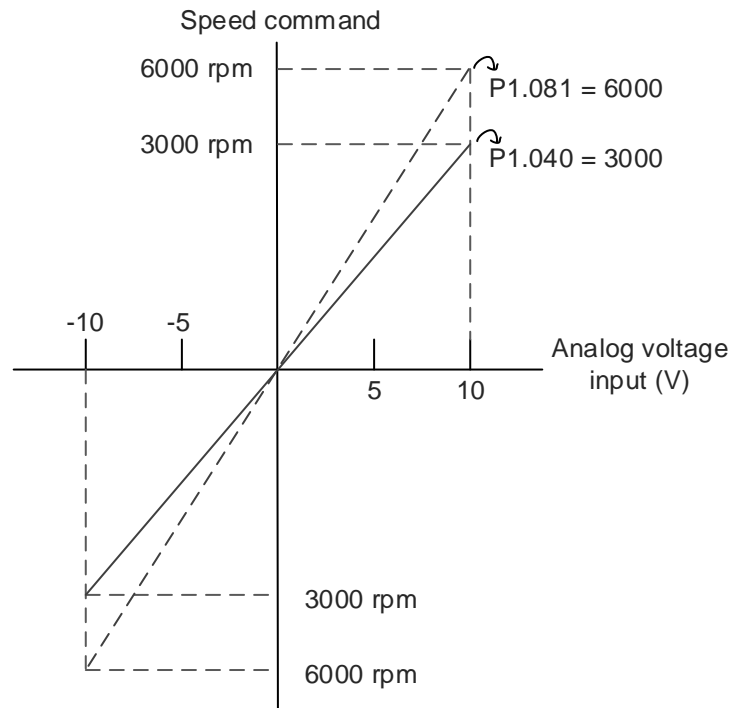

Refer to Chapter 8 for detailed descriptions of the relevant parameters.

Parameter	Function
P1.040	Maximum motor speed for analog Speed command 1
P1.081	Maximum motor speed for analog Speed command 2
P1.082	Time constant for switching between P1.040 and P1.081



### 6.3.5 Timing diagram of Speed mode

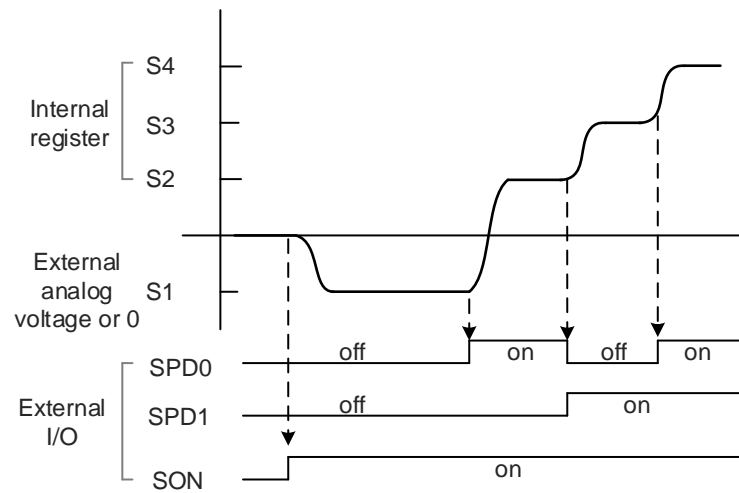

Note:

1. "off" means that DI is off (the circuit is open); "on" means that DI is on (the circuit is closed).
2. When the drive is in Sz mode, the Speed command S1 = 0; when the drive is in S mode, the Speed command S1 is the external analog voltage input.
3. In Servo On state, the command is selected according to the status of SPD0 and SPD1.

### 6.3.6 Gain adjustment of the speed loop

The structure of the Speed control unit is shown in the following diagram.

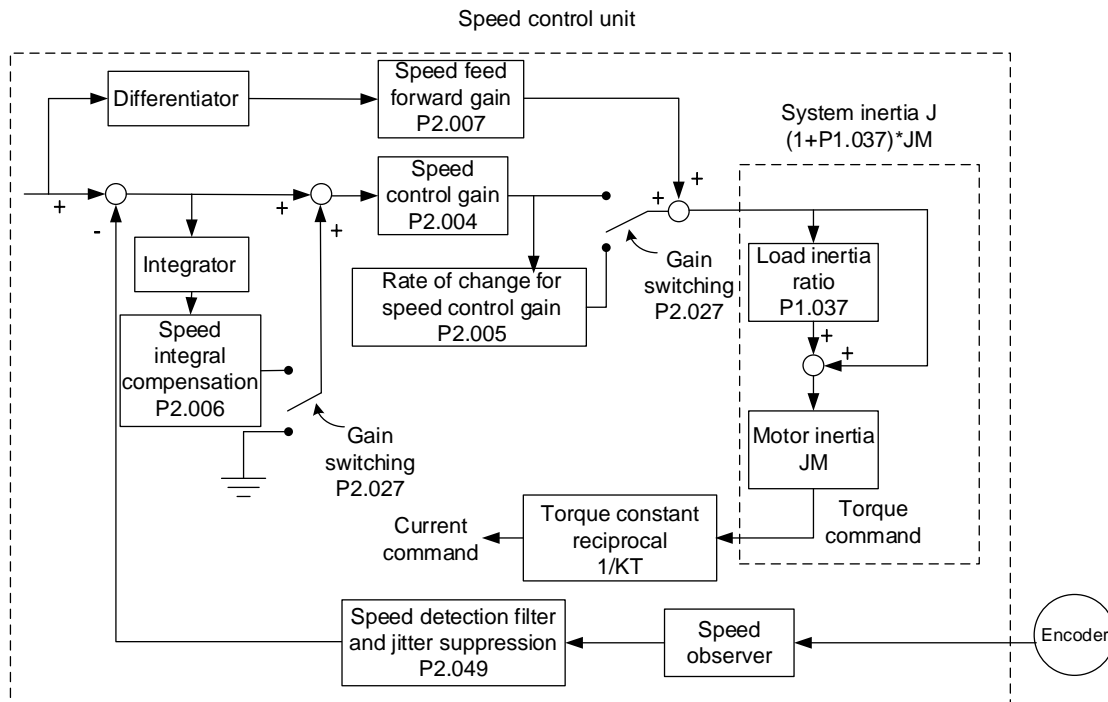

In the Speed control unit, you can adjust different gain parameters. You can adjust the gain manually or use the 5 gain adjustment modes provided.

Manual: manually set the parameters, and all auto or auxiliary functions are disabled.

Gain adjustment mode: refer to Chapter 5 Tuning.

#### Manual mode

When you set P2.032 to 0, you can set the speed control gain (P2.004), speed integral compensation (P2.006), and speed feed forward gain (P2.007).

Speed control gain: the higher the gain, the larger the bandwidth for the speed loop response.

Speed integral compensation: increasing this gain increases the low frequency rigidity and reduces the steady-state error. However, the phase margin is smaller. Setting this gain too high reduces the system stability.

Speed feed forward gain: reduces the deviation of phase delay.

Refer to Chapter 8 for detailed descriptions of the relevant parameters.

Parameter	Function
P2.004	Speed control gain (KVP)
P2.006	Speed integral compensation (KVI)
P2.007	Speed feed forward gain (KVF)

Theoretically, a stepping response can be used to explain proportional gain (KVP), integral gain (KVI), and feed forward gain (KVF). Here, the time domain is used to illustrate the basic principle.

# 6

## Time domain

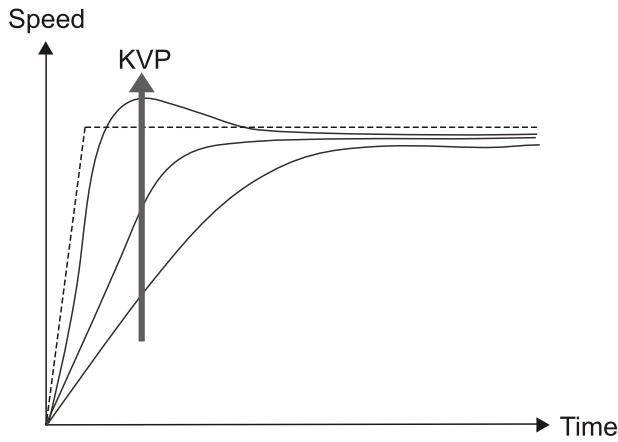

The higher the KVP value, the larger the bandwidth. The time of the speed increase will also be shorter. However, if the KVP value is set too high, the phase margin is too small. The effect is not as good as KVI for the steady-state error but is better for the effect on following error.

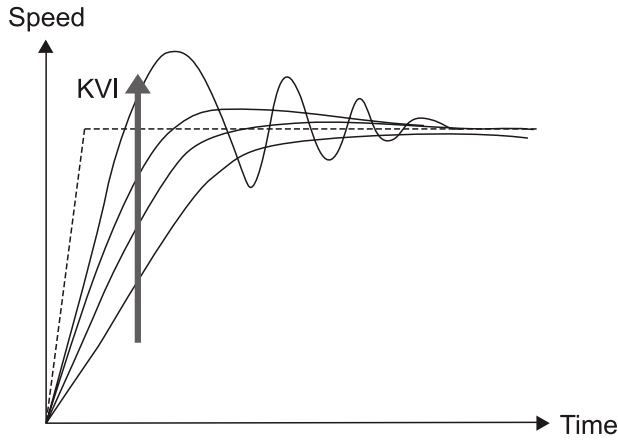

The higher the KVI value, the larger the low-frequency gain. It shortens the time for the steady-state error to reduce to zero. However, it does not significantly reduce the following error.

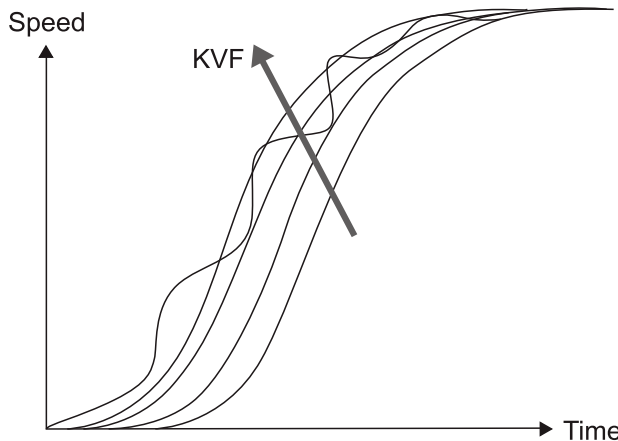

The closer the KVF value is to 1, the more complete the forward compensation. The following error becomes very small. But a KVF value that is set too high also causes vibration.

### 6.3.7 Resonance suppression unit

When resonance occurs, it is probably because the stiffness of the control system is too high or the response bandwidth is too great. Eliminating these two factors can improve the situation. In addition, use the low-pass filter (P2.025) and Notch filter (P2.023, P2.024, P2.043 - P2.046, and P2.095 - P2.103) to suppress the resonance if you want the control parameters to remain unchanged.

Refer to Chapter 8 for detailed descriptions of the relevant parameters.

Parameter	Function
P2.023	Notch filter 1 - frequency
P2.024	Notch filter 1 - attenuation level
P2.043	Notch filter 2 - frequency
P2.044	Notch filter 2 - attenuation level
P2.045	Notch filter 3 - frequency
P2.046	Notch filter 3 - attenuation level
P2.095	Notch filter 1 - Q factor
P2.096	Notch filter 2 - Q factor
P2.097	Notch filter 3 - Q factor
P2.098	Notch filter 4 - frequency
P2.099	Notch filter 4 - attenuation level
P2.100	Notch filter 4 - Q factor
P2.101	Notch filter 5 - frequency
P2.102	Notch filter 5 - attenuation level
P2.103	Notch filter 5 - Q factor
P2.025	Resonance suppression low-pass filter

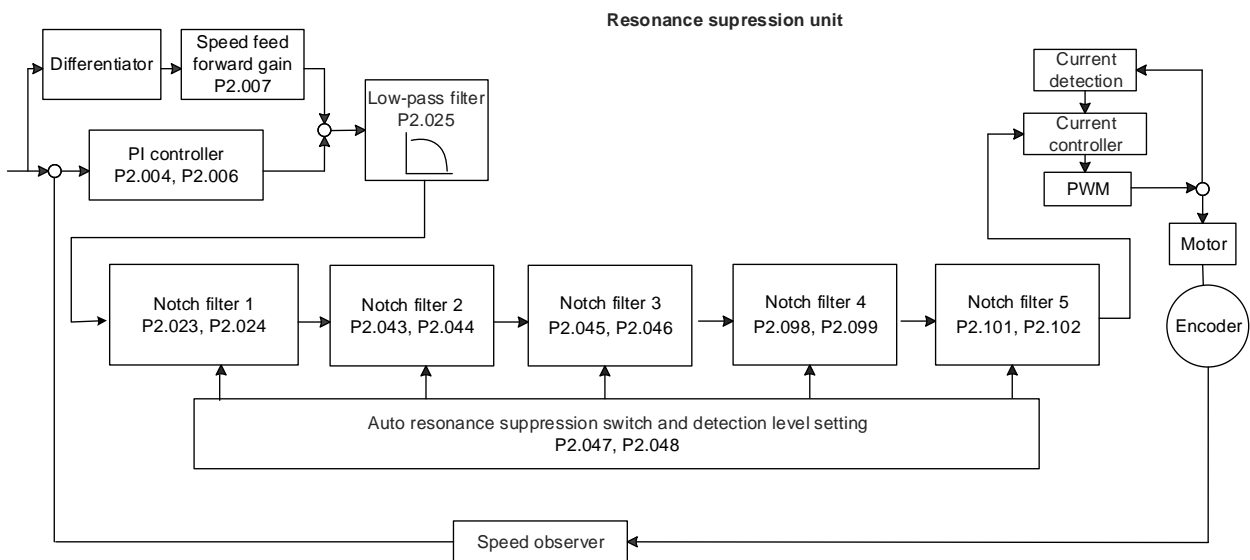

## 6

The servo drive provides two methods for suppressing the resonance: one is the Notch filter and the other is the low-pass filter. See the following diagrams for the results of using these filters.

System open-loop gain with resonance:

■ Notch filter

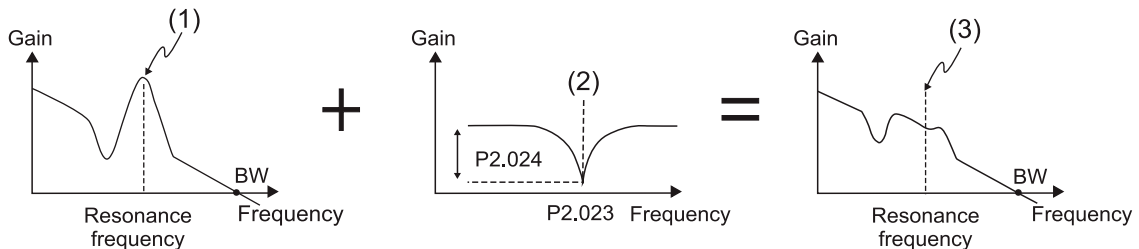

(1) Resonance point; (2) Notch filter; (3) Resonance point suppressed by the Notch filter

■ Low-pass filter

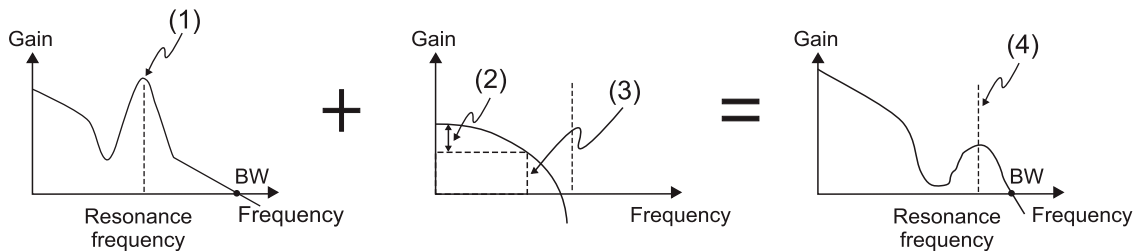

(1) Resonance point; (2) Attenuation rate (-3 dB);

(3) Low-pass filter (Cutoff frequency of low-pass filter =  $1000 / P2.025$  Hz);

(4) Resonance point suppressed by the low-pass filter

To conclude from these two examples, if you increase the value of P2.025 from 0, the bandwidth (BW) becomes smaller. Although it solves the problem of resonance, it also reduces the response bandwidth and phase margin, making the system unstable.

If knowing the resonance frequency, you can suppress the resonance by using the Notch filter, which is better than using the low-pass filter in this condition. If the resonance frequency drifts significantly with time or due to other causes, using the Notch filter is not suggested.

System open-loop gain with resonance:

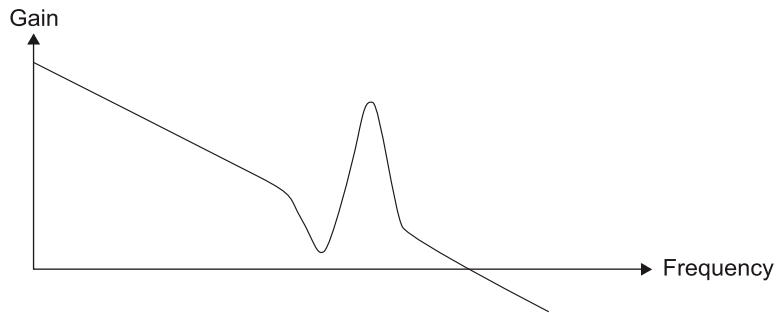

If you increase the value of P2.025 from 0, the bandwidth (BW) becomes smaller (shown as follows). Although it solves the problem of the resonance frequency, it also reduces the response bandwidth and phase margin, making the system unstable.

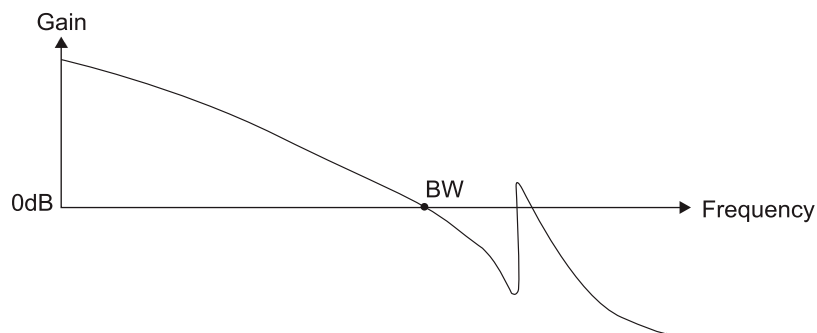

If knowing the resonance frequency, you can suppress the resonance by using the Notch filter. The frequency range of the notch filter is 50 - 5000 Hz and the suppression strength is 0 - 40 dB. If the frequency does not meet the Notch filter conditions, then using the low-pass filter to reduce the resonance is suggested.

## 6

## 6.4 Torque mode

Torque control mode (T or Tz) is suitable for torque control applications, such as printing machines and winding machines. There are two kinds of command sources: analog input and internal register (parameters). The analog command input uses scaled external voltage to control the torque of the motor while the register input uses the internal parameters (P1.012 - P1.014) as the Torque command.

### 6.4.1 Selecting the Torque command source

External analog voltage and internal parameters are the two Torque command sources.

Select the command source with DI signals of CN1. See the following table for more detail.

Torque command number	DI signal of CN1		Command source		Content	Range
	TCM1	TCM0	Mode			
T1	0	0	T	External analog signal	Voltage difference between T_REF and GND	-10V to +10V
			Tz	N/A	Torque command is 0	0
T2	0	1	Internal register parameter		P1.012	-500% to +500%
T3	1	0			P1.013	-500% to +500%
T4	1	1			P1.014	-500% to +500%

- Status of TCM0 - TCM1: 0 means that DI is off (the circuit is open); 1 means that DI is on (the circuit is closed).
- When both TCM0 and TCM1 are 0, if the drive is in Tz mode, then the command is 0. Thus, if the Torque command using analog voltage is not required, you can use Tz mode to avoid zero voltage drift. If the drive is in T mode, the command is the voltage difference between T\_REF and GND. The range of the input voltage is between -10V and +10V, and you can adjust the corresponding torque with P1.041.
- When either one of TCM0 or TCM1 is not 0, the Torque command comes from the internal register. The command is activated once the statuses of TCM0 and TCM1 are switched. There is no need to use DI.CTRG for triggering.

You can use the Torque command in Torque mode (T or Tz) and Speed mode (S or Sz). When it is in Speed mode, you can regard it as the command input for the torque limit.

### 6.4.2 Control structure of Torque mode

The following diagram shows the basic control structure of Torque mode.

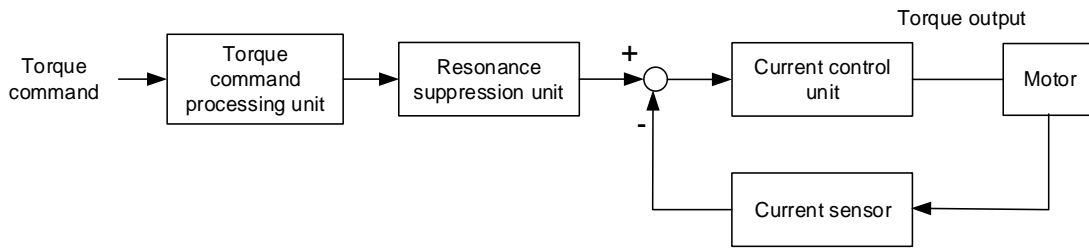

6

The Torque command processing unit selects the command source (see Section 6.4.1), including the scaling parameter (P1.041) for rotation torque and S-curve parameter for smoothing the torque. The current control unit controls the gain parameters of the servo drive and calculates the current for servo motor in real-time.

The structure of Torque command processing unit is as follows:

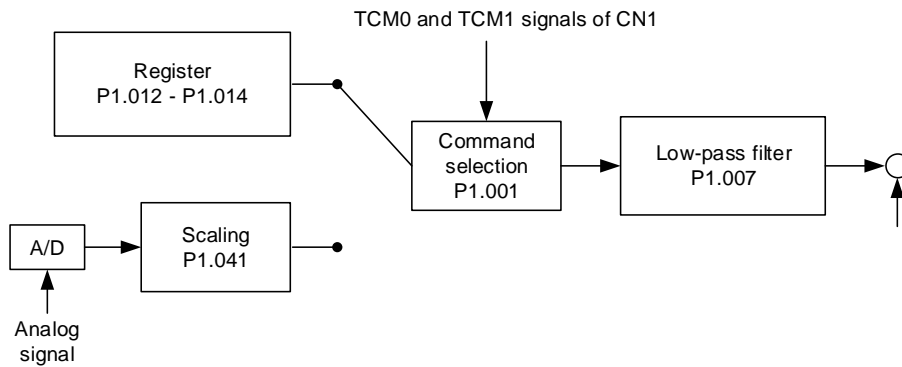

The upper path is the command from the register and the lower one is the command from the external analog voltage, which you can select with the status of TCM0 and TCM1, and P1.001 (T or Tz). Adjust the torque with the analog voltage scaling (P1.041) and smooth the response with the low-pass filter (P1.007).

### 6.4.3 Smooth Torque command

Refer to Chapter 8 for detailed descriptions of the relevant parameter.

Parameter	Function
P1.007	Torque command - smoothing constant (low-pass filter)

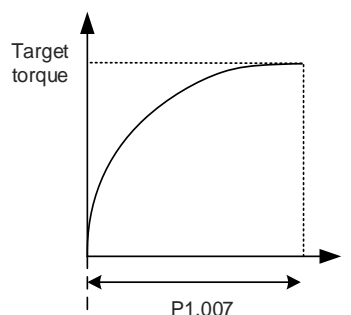



### 6.4.4 Scaling of the analog command

The Torque command is controlled by the analog voltage difference between T\_REF and GND.

Use P1.041 to adjust the slope of the torque and its range.

For example:

1. If you set P1.041 to 100 and the external input voltage is 10V, the Torque command is 100% of the rated torque.
2. If you set P1.041 to 300 and the external input voltage is 10V, the Torque command is 300% of the rated torque.

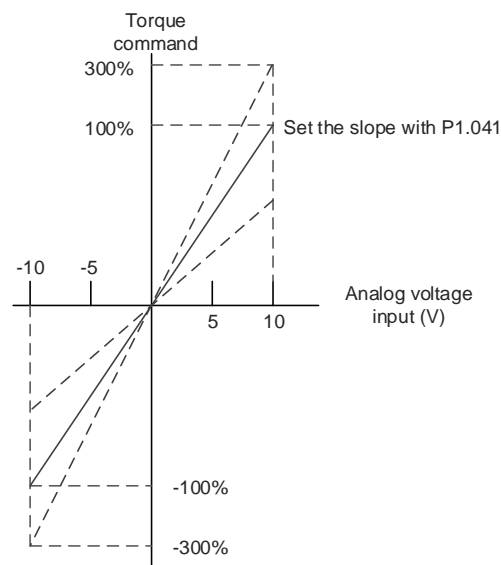

Refer to Chapter 8 for detailed descriptions of the relevant parameter.

Parameter	Function
P1.041	Maximum output for analog Torque command

### 6.4.5 Timing diagram of Torque mode

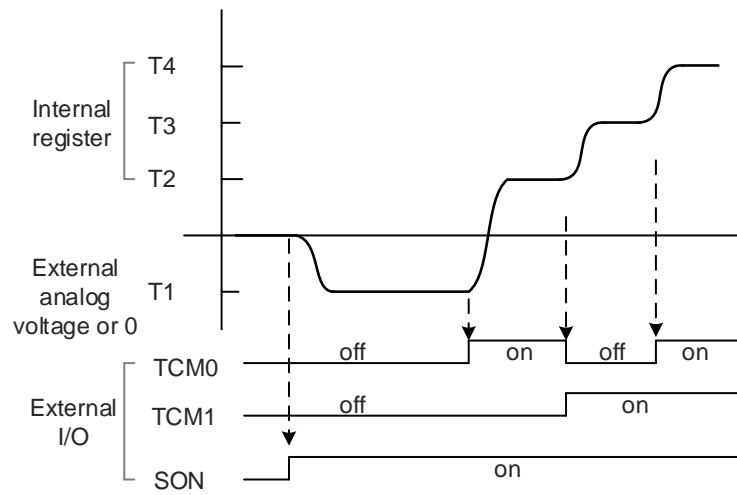

Note:

1. "off" means that DI is off (the circuit is open); "on" means that DI is on (the circuit is closed).
2. When the drive is in Tz mode, the Torque command T1 = 0; when the drive is in T mode, the Torque command T1 is the external analog voltage input.
3. In Servo On state, the command is selected according to the status of TCM0 and TCM1.

## 6.5 Dual mode / Multi-mode

Apart from the single modes for position, speed, and torque, there are also eight dual / multi-modes available for operation (see Section 6.1).

Mode	Short name	Code	Description
Dual mode	PT-S	06	Switch PT and S modes with DI.S-P.
	PT-T	07	Switch PT and T modes with DI.T-P.
	PR-S	08	Switch PR and S modes with DI.S-P.
	PR-T	09	Switch PR and T modes with DI.T-P.
	S-T	0A	Switch S and T modes with DI.S-T.
	PT-PR	0D	Switch PT and PR modes with DI.PT-PR.
Multi-mode	PT-PR-S	0E	Switch PT, PR, and S modes with DI.S-P and DI.PT-PR.
	PT-PR-T	0F	Switch PT, PR, and T modes with DI.T-P and DI.PT-PR.

The dual mode for Sz and Tz is not supported. To avoid occupying too many digital inputs in dual / multi-mode, Speed and Torque modes can use the external analog voltage as the command source to reduce the use of DI points (SPD0, SPD1 or TCM0, TCM1). In addition, Position mode (PT) can use the pulse input to reduce the use of DI points (POS0, POS1, POS2, POS3, POS4, POS5, and POS6).

To refer to the tables of default DI/DO functions or to change the DI/DO functions, see Sections 3.3.2 and 3.3.4 for more information.

### 6.5.1 Speed / Position dual mode

PT-S and PR-S are available in Speed / Position dual mode. The command source for PT-S comes from the external pulse while the source for PR-S comes from the internal parameters (P6 - P7). You can control the Speed command with the external analog voltage or the internal parameters (P1.009 - P1.011). The switch between Speed and Position modes is controlled by DI.S-P (0x18). The switch between PT and PR of Position mode is controlled by DI.PT-PR (0x2B). The following timing diagram illustrates the PR-S mode. The switch between Position and Speed commands in PR-S mode is controlled by DI signals.

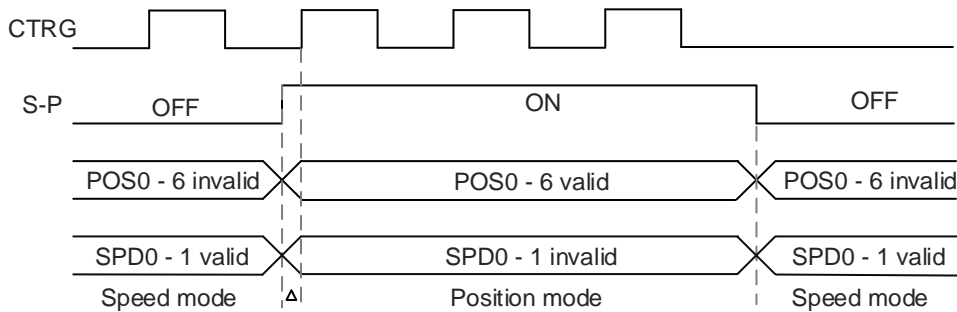

Figure 6.5.1.1 Speed / Position dual mode

In Speed mode (DI.S-P is off), you select the Speed command with DI.SPD0 and DI.SPD1. DI.CTRG is invalid in this mode. When the mode is switched to Position mode (DI.S-P is on), since the Position command has not been issued (it waits for the rising edge of DI.CTRG), the motor stops (indicated by Δ in the preceding figure). The Position command is selected with DI.POS0 - DI.POS6 when the rising edge of DI.CTRG is triggered, and then the motor operates to the specified position. When DI.S-P is off, it returns to Speed mode. Refer to the introduction of single mode for the DI signal and the selected commands for each mode.

## 6

### 6.5.2 Speed / Torque dual mode

Speed / Torque dual mode includes only S-T mode. The command source for Speed command can be the external analog voltage or the internal parameters (P1.009 - P1.011), which you can select with DI.SPD0 and DI.SPD1. Similarly, the source of the Torque command can be the external analog voltage or the internal parameters (P1.012 - P1.014), which you can select with DI.TCM0 and DI.TCM1. The following timing diagram illustrates the S-T mode. The switch between Speed and Torque modes is controlled by DI.S-T (0x19).

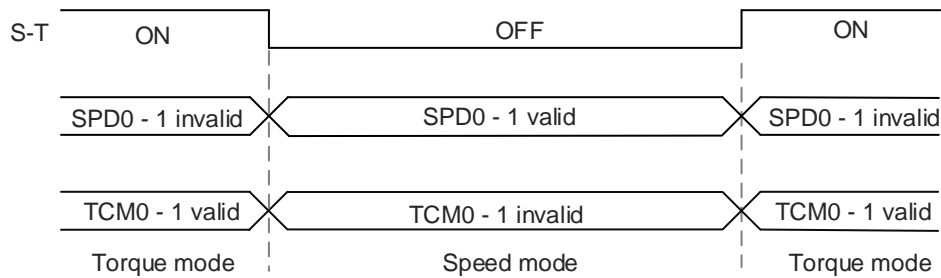

Figure 6.5.2.1 Speed / Torque dual mode

In Torque mode (DI.S-T is on), you select the Torque command with DI.TCM0 and DI.TCM1. When the mode is switched to Speed mode (DI.S-T is off), you select the Speed command with DI.SPD0 and DI.SPD1. Then the motor operates according to the Speed command. When DI.S-T is on, it returns to Torque mode. Refer to the introduction of single mode for the DI signal and the selected commands for each mode.

### 6.5.3 Torque / Position dual mode

Torque / Position dual mode includes PT-T and PR-T. The command source for the Position command of PT-T comes from the external pulse while the source for the Position command of PR-T comes from internal parameters (P6 - P7). The command source for Torque command can be the external analog voltage or the internal parameters (P1.012 - P1.014). The switch between Torque and Position modes is controlled by DI.T-P (0x20). The switch between PT and PR of Position mode is controlled by DI.PT-PR (0x2B). The following timing diagram illustrates the PR-T mode. Position and Torque commands in PR-T mode are switched with DI signals.

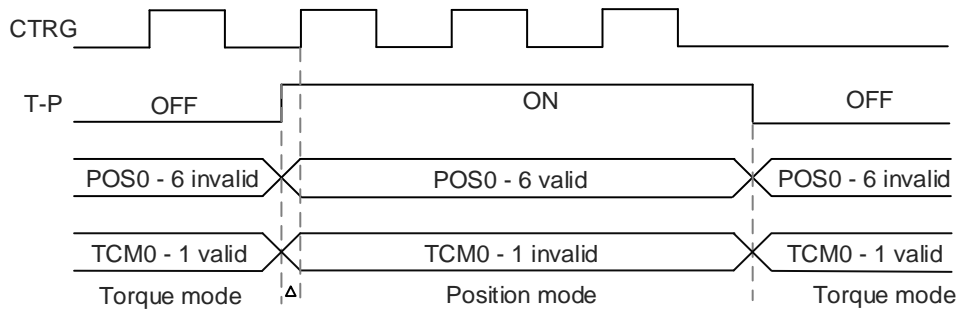

Figure 6.5.3.1 Torque / Position dual mode

In Torque mode (DI.T-P is off), you select the Torque command with DI.TCM0 and DI.TCM1. DI.CTRG is invalid in this mode. When the mode is switched to Position mode (DI.T-P is on), since the Position command has not been issued (it waits for the rising edge of DI.CTRG), the motor stops (indicated by  $\Delta$  in the preceding figure). The Position command is selected with DI.POS0 - DI.POS6 when the rising edge of DI.CTRG is triggered, and then the motor operates to the specified position. When DI.T-P is off, it returns to Torque mode. Refer to the introduction of single mode for the DI signal and the selected commands for each mode.

## 6

## 6.6 Others

### 6.6.1 Applying the speed limit

No matter the servo drive is in Position, Speed, or Torque mode, the maximum motor speed is determined by the internal parameter (P1.055). The methods for using the Speed Limit command and Speed command are the same. You can use either the external analog voltage or the internal parameters (P1.009 - P1.011). Refer to Section 6.3.1 for more details.

The speed limit is applicable only in Torque mode (T) for controlling the motor's maximum speed. If you are using the external analog voltage in Torque mode, you can use the available DI signals to set SPD0 and SPD1 for the motor speed limit value (internal parameters). If there is no available DI signals, use the analog voltage input for the Speed Limit command. When you set P1.002 (disable / enable speed limit function) to 1, you enable the Speed Limit function.

The timing diagram is shown as follows.

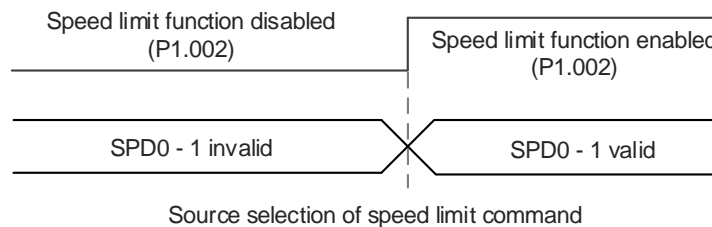

### 6.6.2 Applying the torque limit

The methods for using the Torque Limit command and Torque command are the same. You can use either the external analog voltage or the internal parameters (P1.012 - P1.014). Refer to Section 6.4.1 for more details.

The torque limit is applicable in Position mode (PT and PR) or Speed mode (S) for limiting the motor torque output. If you are using the external pulse in Position mode or using the external analog voltage in Speed mode, you can use the available DI signals to set TCM0 and TCM1 for the torque limit command (internal parameters). If there is no available DI signals, use the analog voltage input for the Torque limit command. When you set P1.002 (disable / enable torque limit function) to 1, you enable the Torque Limit function. The timing diagram is shown as follows.

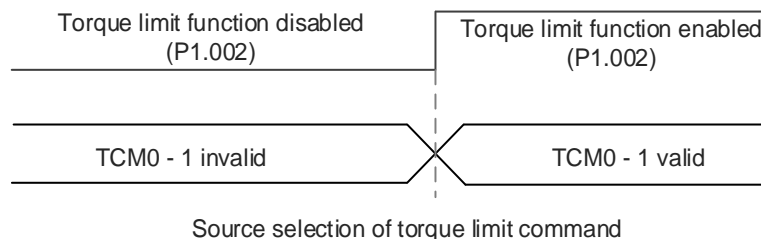

### 6.6.3 Analog monitoring

You can find the required voltage signal with analog monitoring. The servo drive provides two analog channels, which wiring information is detailed in Chapter 3

Refer to Chapter 8 for detailed descriptions of the relevant parameters.

Parameter	Function
P0.003	Analog output monitoring
P1.003	Encoder pulse output polarity
P1.004	MON1 analog monitor output proportion
P1.005	MON2 analog monitor output proportion
P4.020	Analog monitor output (Ch1) - offset compensation value
P4.021	Analog monitor output (Ch2) - offset compensation value

Example:

To specify a motor speed of 1,000 rpm, which corresponds to analog voltage output of 8V with the maximum speed of 5,000 rpm, the setting is as follows:

$$P1.004 = \frac{\text{Required speed}}{\text{Maximum speed}} \times 100\% = \frac{1000 \text{ rpm}}{5000 \text{ rpm}} \times 100\% = 20\%$$

You can calculate the voltage output corresponding to the current motor speed with the following formula.

Motor speed	MON1 analog monitoring output
300 rpm	$MON1 = 8V \times \frac{\text{Current speed}}{\text{Maximum speed} \times \frac{P1.004}{100}} \times 100\% = 8V \times \frac{300 \text{ rpm}}{5000 \text{ rpm} \times \frac{20}{100}} \times 100\% = 2.4V$
900 rpm	$MON1 = 8V \times \frac{\text{Current speed}}{\text{Maximum speed} \times \frac{P1.004}{100}} \times 100\% = 8V \times \frac{900 \text{ rpm}}{5000 \text{ rpm} \times \frac{20}{100}} \times 100\% = 7.2V$

Voltage drift:

When voltage drift occurs, the voltage level defined as zero voltage is different from the set zero point. To fix this problem, you can use DOF1 (P4.020) and DOF2 (P4.021) to calibrate the voltage output offset. The voltage level for analog monitoring output is ±8V. If the output voltage exceeds the range, it is limited within ±8V. The resolution is approximately 10 bits, which is equivalent to 13 mV/LSB.

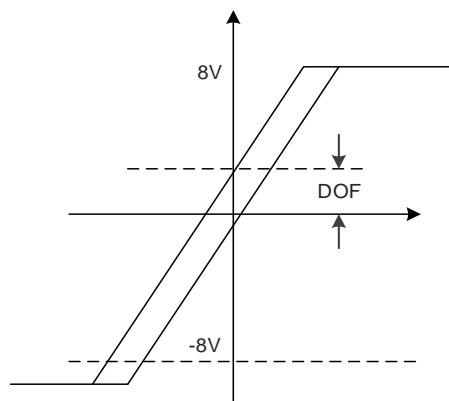



6

### 6.7 Full-closed loop control system

The auxiliary encoder returns the actual position of the machine end to the servo drive in the full-closed loop system, which improves the conditions of lead screw backlash, flexibility of couplings or belts, and thermal expansion, linearity, and sliding end of the transmission system, achieving high-precision positioning.

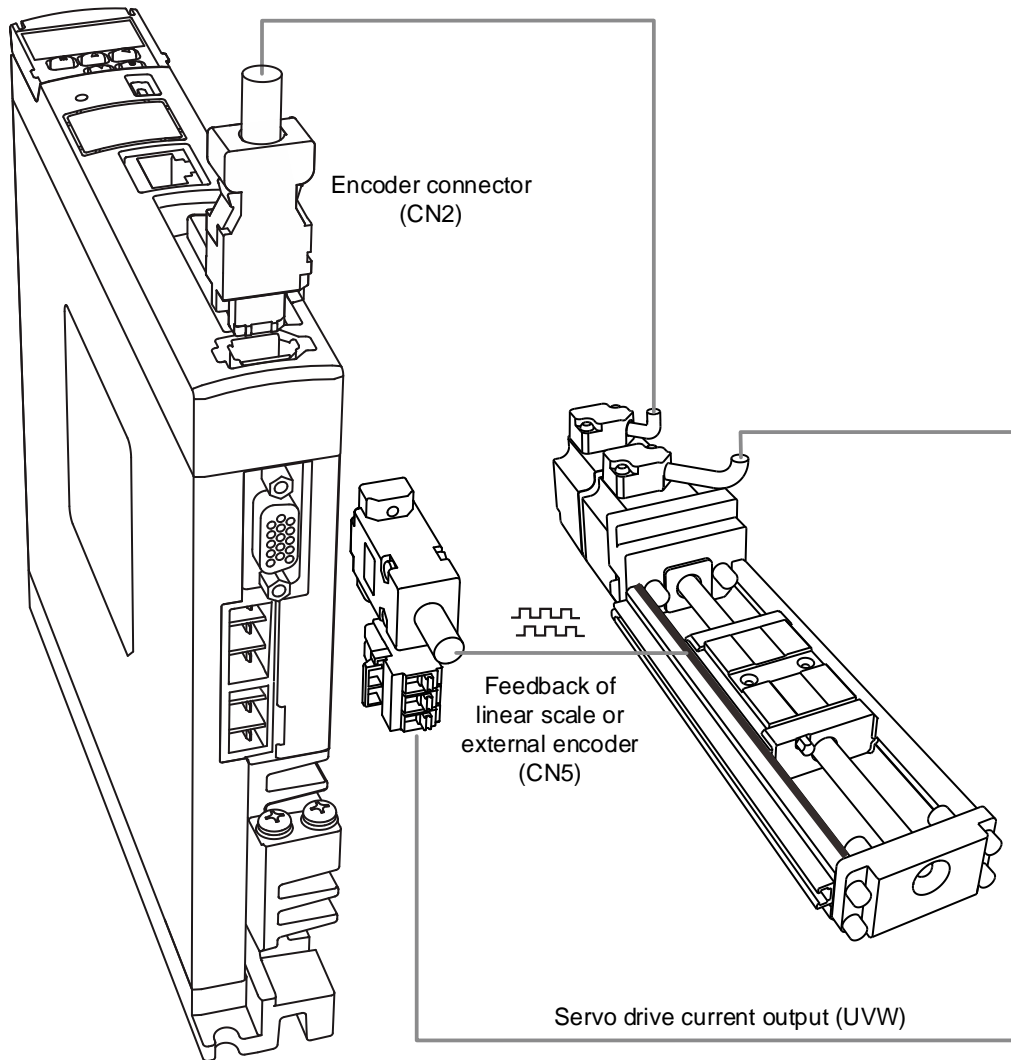

### 6.7.1 Hardware configuration

The CN5 connector is for connecting to the auxiliary encoder (A, B, and Z phase signals) and forms a full-closed loop with the servo system.

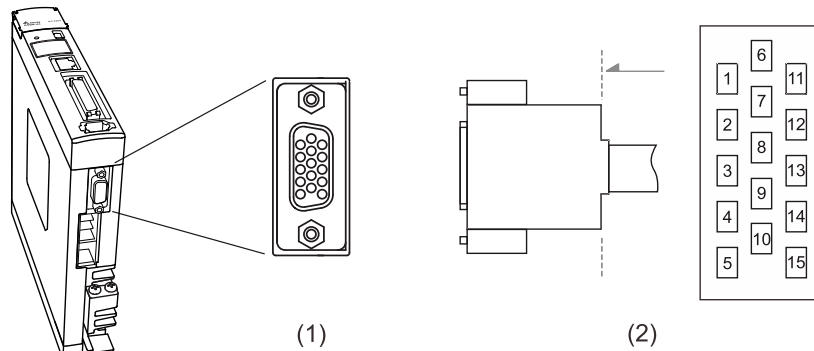

(1) CN5 connector (female); (2) CN5 connector (male)

Pin assignment:

Pin No.	Signal	Description
1	Opt_/Z	/Z phase input
2	Opt_/B	/B phase input
3	Opt_B	B phase input
4	Opt_A	A phase input
5	Opt_/A	/A phase input
6	GND	Ground for the encoder and Hall sensor
7	GND	Ground for the encoder and Hall sensor
8	+5V	Encoder power
9	Opt_Z	Z phase input
10	HALL_U	Hall sensor U phase input
11	HALL_V	Hall sensor V phase input
12	HALL_W	Hall sensor W phase input
13	TEMP+	Motor temperature detection
14	TEMP-	Motor temperature detection
15	-	Reserved
Case	Shielding	Shielding

Note: the motor temperature detection function supports NTC type and PTC type sensors.

Refer to Chapter 8 for detailed parameter settings of PM.022 and PM.024.

## 6

Specifications and wiring descriptions for the CN5 signals:

Signal type	Hall sensor	A, B, Z phase signals
Operating voltage	5V	5V
Signal format	Single-ended	Differential
Encoder power (5V) output	$\leq 300$ mA	$\leq 300$ mA
Pull-up resistor (R)	$\leq 20$ k $\Omega$ <sup>1</sup>	-
Max. pulse frequency	5 kHz	Single-phase pulse frequency: 4 MHz
V <sub>HALL</sub> voltage	High-level voltage > 3.2V (Min.) Low-level voltage < 2.2V (Max.)	-

Note:

1. If the servo drives are manufactured before week 50 of year 2017 (serial numbers: before T1750 and W1750), they only support Hall sensors with built-in pull-up resistors. If there is no built-in pull-up resistors, you need to connect to external ones.
2. If the servo drives are manufactured in week 50 of year 2017 or later (serial numbers: T1750 and W1750, or later), the servo drives support Hall sensors with or without built-in pull-up resistors.

### 6.7.2 Control structure

#### Full-closed loop control structure in PT mode

When the servo is in full-closed loop control in PT mode, if the E-Gear ratio is set to  $\frac{1}{1}$ , one pulse from the command corresponds to one quadruple-frequency pulse from the auxiliary encoder. If the E-Gear ratio is set to  $\frac{2}{1}$ , one pulse from the command corresponds to two quadruple-frequency pulses from the auxiliary encoder.

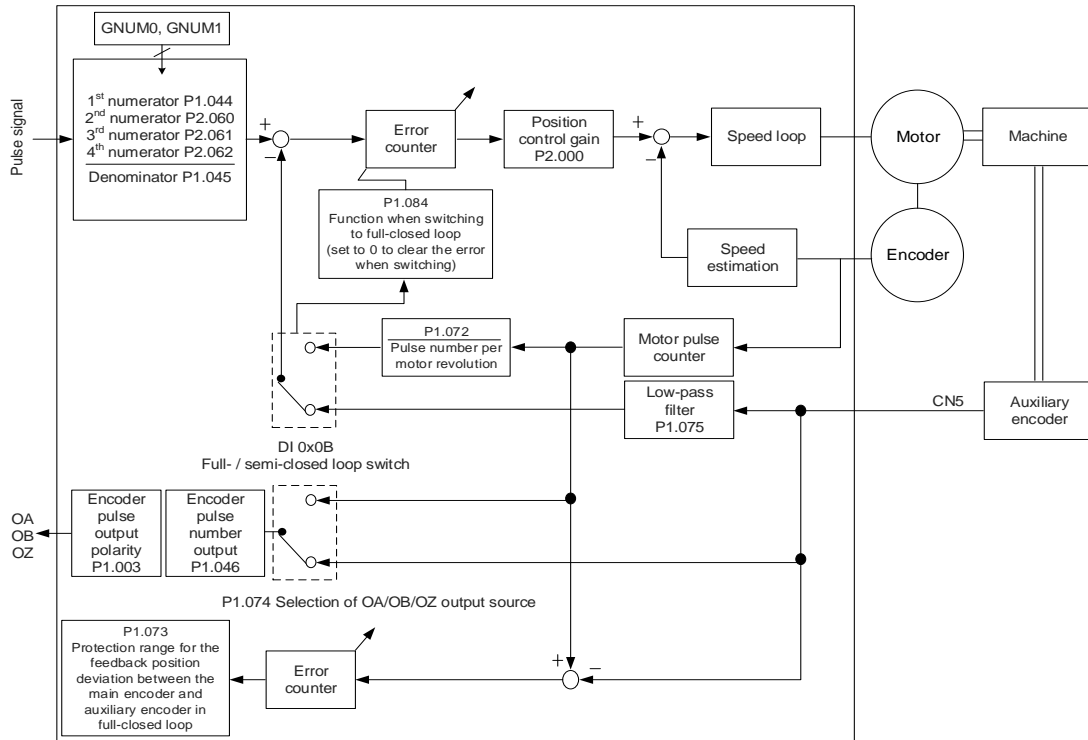

6

**Full-closed loop control structure in PR mode**

The servo is in full-closed loop control in PR mode when you enable the full-closed loop function in the communication mode (with P1.001 set to B or C). When the servo is in full-closed loop control in PR mode, if the E-Gear ratio is set to  $\frac{1}{4}$ , one PUU from the command corresponds to one quadruple-frequency pulse from the auxiliary encoder. If the E-Gear ratio is set to  $\frac{2}{4}$ , one PUU from the command corresponds to two quadruple-frequency pulses from the auxiliary encoder.

Note: PR full-closed loop function is not yet supported.

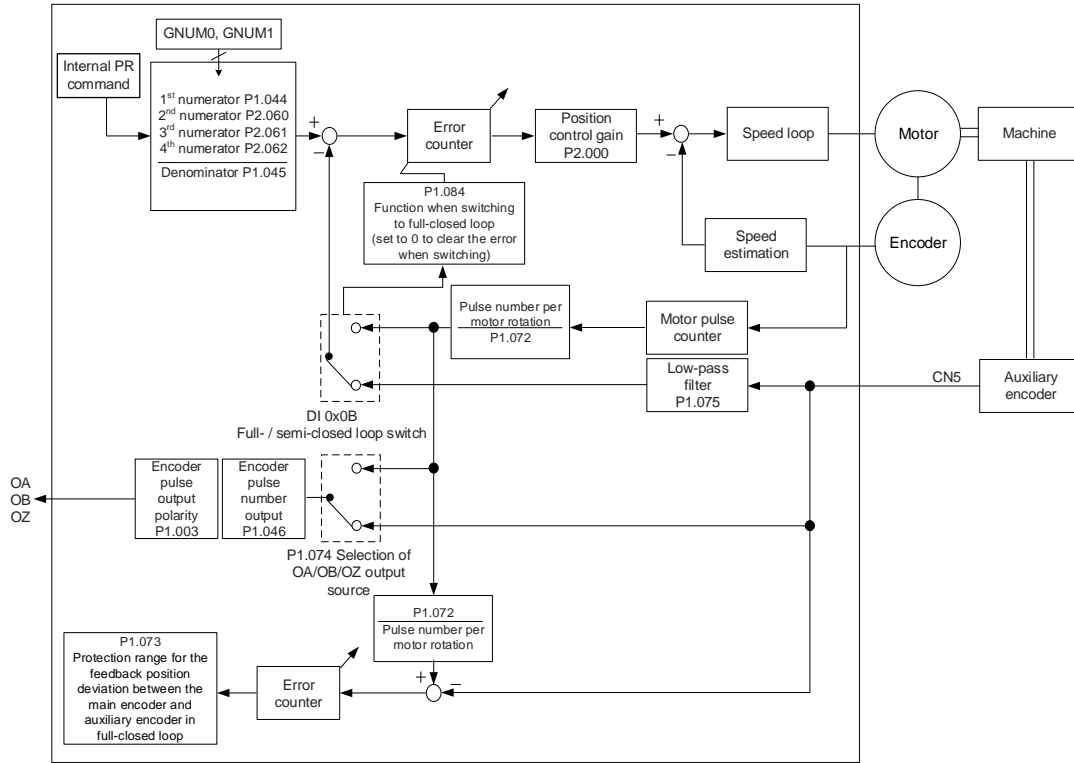

### 6.7.3 Steps for setting the full-closed loop function

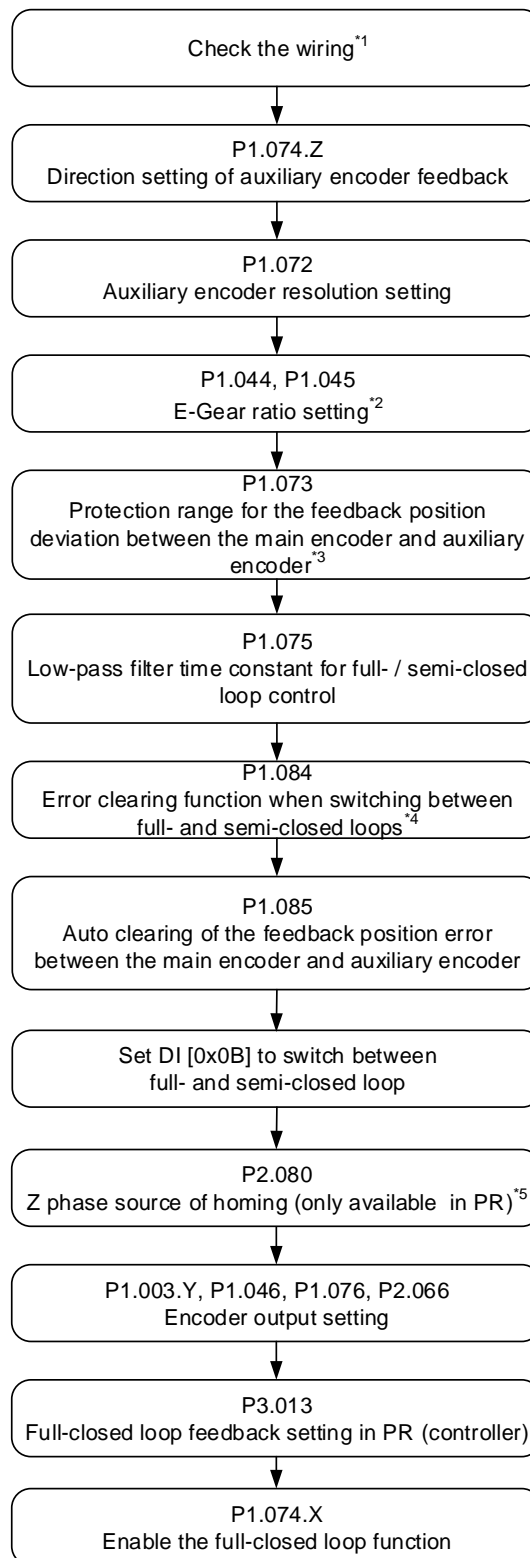

**Note:**

1. The auxiliary encoder (A, B, and Z phase signals) is connected to the CN5 on the servo drive to form a full-closed loop. You can monitor whether the drive receives the feedback position from the auxiliary encoder with P5.017.
2. Set the E-Gear ratio to 1 : 1.

## 6

3. When setting the full-closed loop function for the first time, do not set the value of P1.073 too great to prevent the auxiliary encoder from disconnection or prevent the motor from continuous operation caused by inverse direction.
4. This parameter is not available in PR mode. In PR mode, the error is automatically cleared when the system switches between full- and semi-closed loops.
5. PR full-closed loop function is not yet supported.

## 6.7.4 Parameters for full-closed loop function

### 6.7.4.1 Auxiliary encoder direction setting

P1.074	Full-closed loop control switch		Address: 0194H 0195H
Default:	0x0000	Control mode:	PT / PR* (full-closed loop)
Unit:	-	Setting range:	0000h - F132h
Format:	HEX	Data size:	16-bit

Settings:

U Z Y X

X	Full-closed loop / Gantry function switch	Z	Feedback direction (positive / negative) of auxiliary encoder
Y	Selection of OA / OB / OZ output source	U	Filter width setting for CN5 feedback pulse

- Z: feedback direction (positive / negative) of auxiliary encoder
  - 0: pulse output in positive direction
  - 1: pulse output in negative direction

Note: PR full-closed loop function is not yet supported.

Before using the full-closed loop control function, check if the feedback position of the auxiliary encoder increases or decreases in the same direction as the motor encoder. If the feedback directions are inverse, change the setting value of P1.074.Z to reverse the direction for the signal of the auxiliary encoder.

Here are the steps for checking the directions.

Step 1: disable the full-closed loop function by setting P1.074.X to 0.

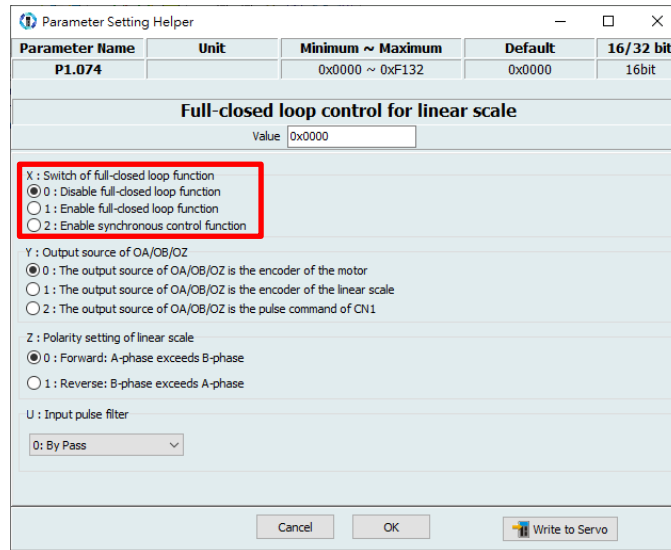

Step 2: open the Scope function of ASDA-Soft, select Feedback position [PUU] for CH1 and Auxiliary encoder feedback [Pulse] for CH2, and then click **Start** to start the scope.

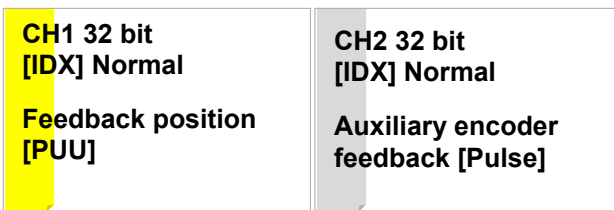

Use the JOG function to operate the motor in a single direction at a low speed. If you get two feedback signals which are in inverse directions (shown as follows), go on to Step 3 to adjust the parameter.

Note: set P3.013.X to 0 when checking the directions.

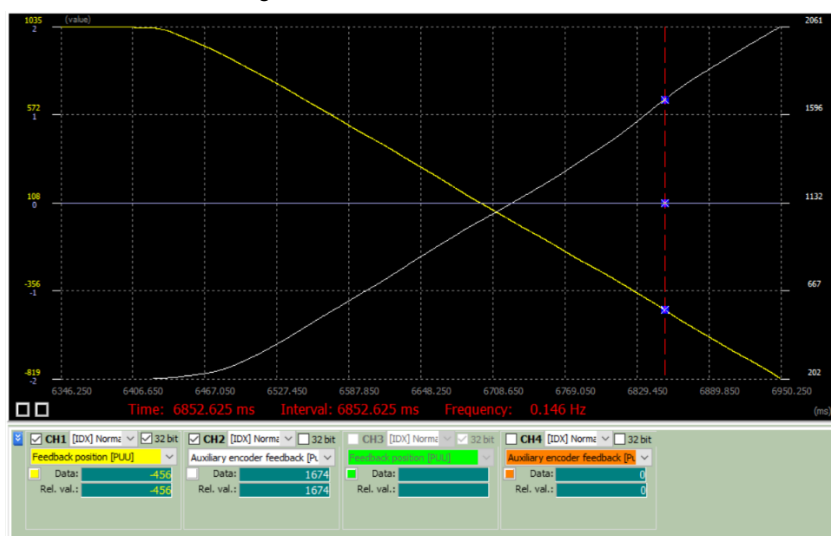



6

Step 3: the two feedback signals are in inverse directions due to the previous setting of P1.074.Z. Switch P1.074.Z to the other setting.

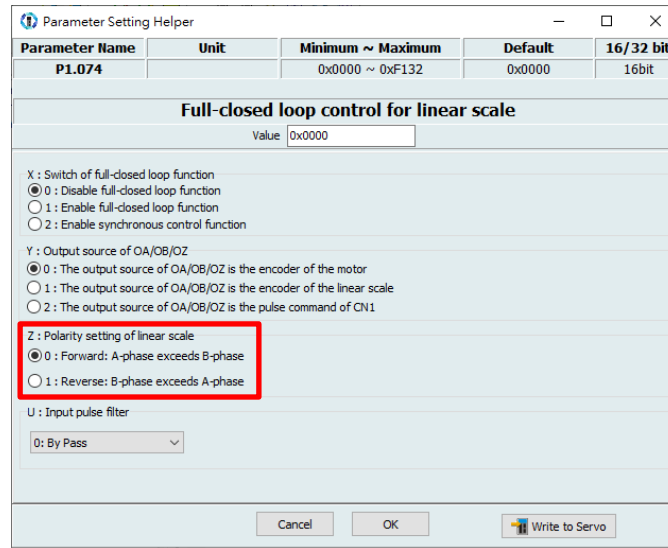

Step 4: go back to Step 2 to ensure the feedback signals of the main encoder and auxiliary encoder increase or decrease in the same direction.

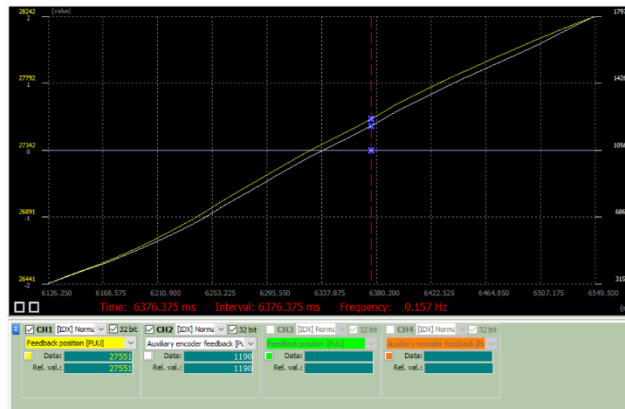

### 6.7.4.2 Auxiliary encoder resolution setting

P1.072	Resolution of auxiliary encoder for full-closed loop control		Address: 0190H 0191H
Default:	5000	Control mode:	PT / PR* (full-closed loop)
Unit:	pulse/rev	Setting range:	200 - 1280000
Format:	DEC	Data size:	32-bit

Settings:

The number of A/B pulses corresponding to a full-closed loop when the motor runs a cycle (after quadruple frequency).

Note: PR full-closed loop function is not yet supported.

There are two methods for calculating the corresponding pulse number of the auxiliary encoder per motor revolution. One method calculates the theoretical value from the physical quantity. The other calculates the actual value with the Scope function of ASDA-Soft. If the resolution of auxiliary encoder for full-closed loop control (P1.072) is incorrectly set, the position error between the auxiliary encoder feedback and the motor encoder accumulates during long-term operation, triggering AL040.

#### 1. Calculating the theoretical value

If the machine using screw transmission forms a full-closed loop control system with the auxiliary encoder, the screw pitch and resolution of the auxiliary encoder are required for calculating the corresponding pulse number of the auxiliary encoder per motor revolution. When the specifications of the screw and auxiliary encoder are known, you can calculate the value of P1.072.

Example:

If the screw pitch is 5 mm and the resolution of the linear scale (auxiliary encoder) is 0.5  $\mu\text{m}$ , the calculation is as follows.

$$\frac{5 \text{ mm}}{0.5 \mu\text{m}} = \frac{5000 \mu\text{m}}{0.5 \mu\text{m}} = 10000 \text{ pulse} = \text{P1.072}$$

When the motor runs a cycle, the linear scale requires to receive 10,000 pulses.

6

2. Calculating the actual value

Calculating theoretical values is infeasible if the system does not use screws for transmission or the system consists of complex mechanical parts. In this case, use the JOG function to operate the motor in a single direction at low speed when the full-closed loop function is disabled, and then calculate the value of P1.072 by using the Feedback position [PUU] and Auxiliary encoder feedback [Pulse] observed with the Scope function of ASDA-Soft.

Step 1: disable the full-closed loop function by setting P1.074.X to 0.

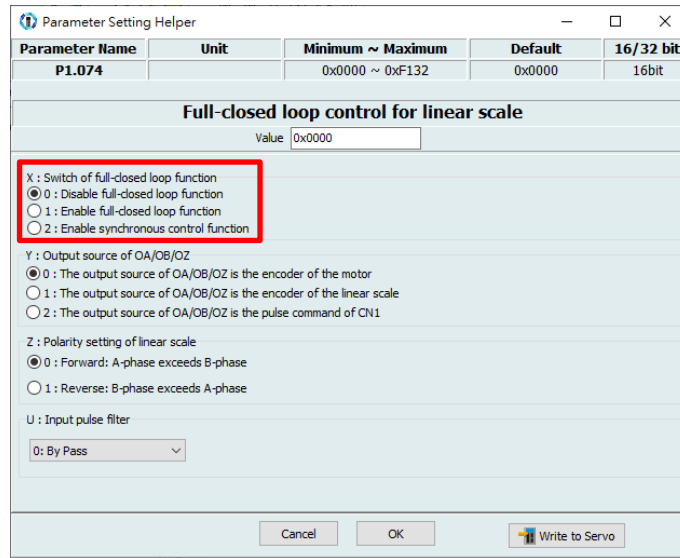

Step 2: open the Scope function, select Feedback position [PUU] for CH1 and Auxiliary encoder feedback [Pulse] for CH2, and then click **Start** to start the scope.

<p><b>CH1 32 bit</b>  <b>[IDX] Normal</b></p> <p><b>Feedback position</b>  <b>[PUU]</b></p>	<p><b>CH2 32 bit</b>  <b>[IDX] Normal</b></p> <p><b>Auxiliary encoder</b>  <b>feedback [Pulse]</b></p>
---	--

Use the JOG function to operate the motor in a single direction at low speed, and observe the position feedback from the two channels as shown in the following figure.

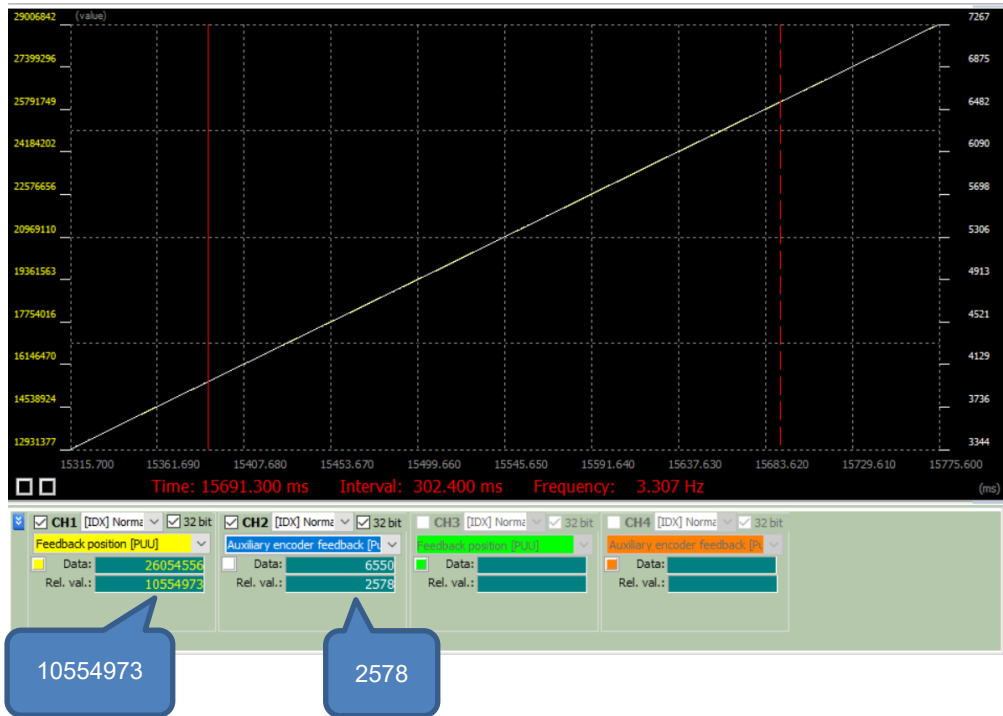

6

Observe the relative values (Rel. val.) of the two channels during a specific time period. As shown in the preceding figure, the Feedback position is 10,554,973 PUU and the Auxiliary encoder feedback is 2,578 pulses. According to the following formula, when the motor runs a cycle, the auxiliary encoder actually receives approximately 4,094 pulses.

$$\left| \frac{\text{Auxiliary encoder feedback (Pulse)} \times P1.044}{\text{Feedback position (PUU)} \times P1.045} \right| = \frac{10554973 \times 1}{2578 \times 1} \approx 4094$$

6

6.7.4.3 E-Gear settings

When the servo is in full-closed loop control, set both P1.044 and P1.045 to 1 and set the E-Gear ratio to the controller parameter.

6.7.4.4 Setting the protection range for the feedback position error between the main encoder and auxiliary encoder

<b>P1.073</b>	<b>Protection range for feedback position error between main encoder and auxiliary encoder</b>		<b>Address: 0192H 0193H</b>
Default:	30000	Control mode:	PT / PR* (full-closed loop)
Unit:	pulse (based on the feedback of full-closed loop)	Setting range:	1 to (2 <sup>31</sup> -1)
Format:	DEC	Data size:	32-bit

Settings:

In full-closed loop control, when the feedback position difference between the auxiliary encoder and the main encoder is too great, it means the connectors are loose or there is a problem with the mechanical part. When the difference is greater than the value of P1.073, AL040 (Excessive position error of full-closed loop control) occurs.

$$P1.073 < \left( \text{Main encoder position [PUU]} \times \frac{P1.044 \times P1.072}{P1.045 \times 16777216} \right) - \text{Auxiliary encoder position [Pulse]}$$

In the preceding expression:

Main encoder position [PUU] = Feedback position [PUU] (when P1.074.X = 0) - Feedback position [PUU] (when P1.074.X = 1)

Auxiliary encoder position [Pulse] = Auxiliary encoder feedback [Pulse] (when P1.074.X = 0) - Auxiliary encoder feedback [Pulse] (when P1.074.X = 1)

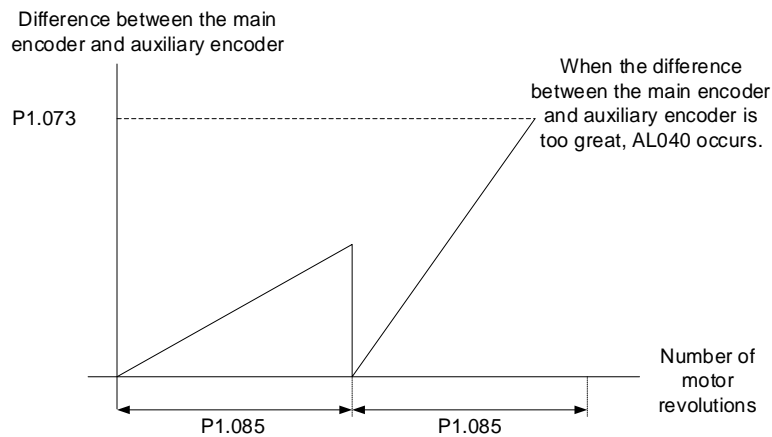

Note: PR full-closed loop function is not yet supported.

### 6.7.4.5 Setting the low-pass filter time constant for full- / semi-closed loop control

P1.075	Low-pass filter time constant for full- / semi-closed loop control		Address: 0196H 0197H
Default:	100	Control mode:	PT / PR* (full-closed loop)
Unit:	ms	Setting range:	0 - 1000
Format:	DEC	Data size:	16-bit

#### Settings:

When the stiffness of the mechanical system between full- and semi-closed loops is insufficient, set the proper time constant to enhance the stability of the system. In other words, create a semi-closed loop effect in the transient state. After the system reaches a steady state, the full-closed loop effect is created. When the stiffness is sufficient, set to bypass. Set the value to 0 to disable the low-pass filter function (bypass).

If the stiffness of the mechanical system is high, decrease the value of P1.075 or set the value to 0 to disable the low-pass filter function. If the stiffness of the mechanical system is low, increase the value of P1.075.

Note: PR full-closed loop function is not yet supported.

## 6

### 6.7.4.6 Setting the error clearing function when switching between full- and semi-closed loops

P1.084	Error clearing function when switching between full- and semi-closed loops		Address: 01A8H 01A9H
Default:	0x0000	Control mode:	PT / PR* <sup>1</sup> (full-closed loop)
Unit:	-	Setting range:	0x0000 - 0x0001
Format:	HEX	Data size:	16-bit

Settings:

U Z Y X

X	Error clearing function when the system switches from semi-closed loop to full-closed loop	Z	Reserved
Y	Reserved	U	Reserved

- X: error clearing function when the system switches from semi-closed loop to full-closed loop<sup>2</sup>

0: clear the error when switching.

When the system is in semi-closed loop control, the command refers to the motor encoder, and the position does not move after the system switches to full-closed loop.

1: no clearing of the error when switching.

When the system is in semi-closed loop control, the command refers to the motor encoder.

After the system switches to full-closed loop, the command issued in semi-closed loop becomes the full-closed loop command, and thus the position moves.

Note:

1. PR full-closed loop function is not yet supported.
2. Use DI [0x0B] to switch between full- and semi-closed loop modes.

Example:

- Error clearing enabled (P1.084.X = 0)

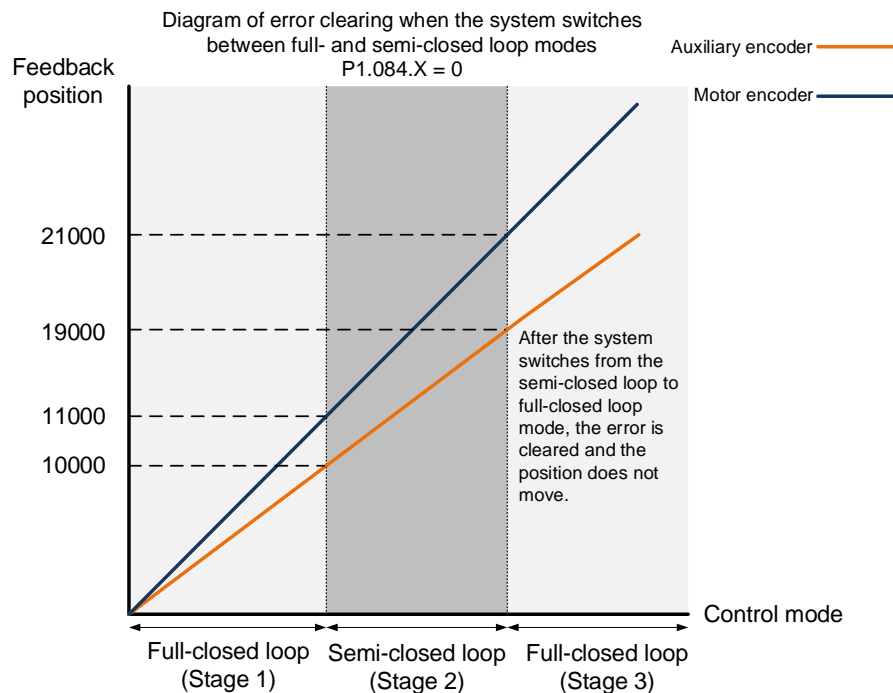

#### Stage 1: full-closed loop control (feedback position of the auxiliary encoder)

If the servo drive issued a position command of 10,000 PUU and the feedback position of the auxiliary encoder is 10,000 PUU, the final feedback position of the motor encoder is 11,000 PUU due to the backlash and sliding of the mechanical parts.

#### Stage 2: semi-closed loop control (feedback position of the motor encoder)

Use DI [0x0B] to switch the control mode from full-closed loop to semi-closed loop, and then issue the position command of 10,000 PUU again. In semi-closed loop control, since the command refers to the position of the motor encoder, the feedback position of the motor encoder is 21,000 PUU, but the feedback position of the auxiliary encoder is 19,000 PUU.

In this mode, there is an error of 1,000 PUU between the auxiliary encoder (19,000 PUU) and the position command (20,000 PUU).

#### Stage 3: full-closed loop control (feedback position of the auxiliary encoder)

When you set P1.084 to 0, the error will be cleared. Thus, after using DI [0x0B] to switch the control mode from semi-closed loop to full-closed loop, the feedback position of the auxiliary encoder is not corrected.



- Error clearing disabled (P1.084.X = 1)

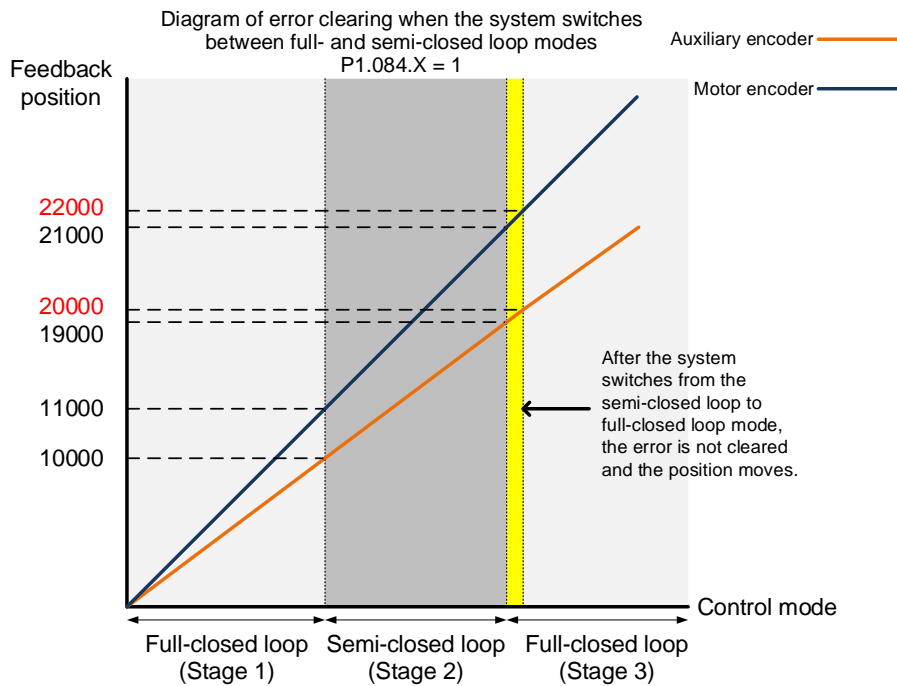

#### Stage 1: full-closed loop control (feedback position of the auxiliary encoder)

If the servo drive issued a position command of 10,000 PUU and the feedback position of the auxiliary encoder is 10,000 PUU, the final feedback position of the motor encoder is 11,000 PUU due to the backlash and sliding of the mechanical parts.

#### Stage 2: semi-closed loop control (feedback position of the motor encoder)

Use DI [0x0B] to switch the control mode from full-closed loop to semi-closed loop, and then issue the position command of 10,000 PUU again. In semi-closed loop control, since the command refers to the position of the motor encoder, the feedback position of the motor encoder is 21,000 PUU, but the feedback position of the auxiliary encoder is 19,000 PUU.

In this mode, there is an error of 1,000 PUU between the auxiliary encoder (19,000 PUU) and the position command (20,000 PUU).

#### Stage 3: full-closed loop control (feedback position of the auxiliary encoder)

When you set P1.084 to 1, the error will not be cleared. Thus, after using DI [0x0B] to switch the control mode from semi-closed loop to full-closed loop, the feedback position of the auxiliary encoder is corrected and the motor moves to the corresponding position (yellow area as shown in the above figure). The previous semi-closed loop command becomes the full-closed loop command and refers to the auxiliary encoder to move the mechanical part to the position corresponding to the actual command. The final feedback position of the auxiliary encoder is 20,000 PUU.

**6.7.4.7 Auto clearing of the feedback position error between the main encoder and auxiliary encoder**

<b>P1.085</b>	<b>Auto clearing of the feedback position error between the main encoder and auxiliary encoder</b>	<b>Address: 01AAH 01ABH</b>	
Default:	0	Control mode:	PT / PR* (full-closed loop)
Unit:	rev	Setting range:	0 - 32768 (0: disable this function)
Format:	DEC	Data size:	16-bit

Settings:

This parameter sets the upper limit of the feedback position error between the main encoder and auxiliary encoder. When the number of motor revolutions is greater than or equal to this parameter value, the system automatically clears the error.

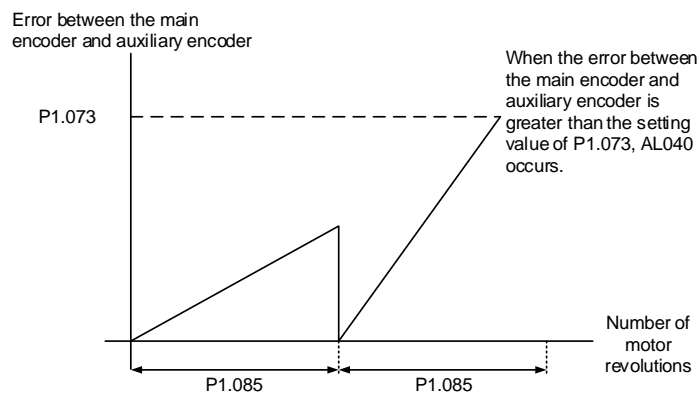

## 6

**6.7.4.8 Set DI [0x0B] to switch between full- and semi-closed loop modes**

DI [0x0B] is effective only when the full-closed loop function is enabled (P1.074.X = 1).

When the full-closed loop function is disabled, the setting of P1.072 is ignored.

Example 1 illustrates the semi-closed loop function in full-closed loop mode and Example 2 illustrates the semi-closed loop function which you usually use. The setting of P1.072 is effective when the full-closed loop function is enabled, so pay special attention when using the semi-closed loop functions.

Example 1: enable the full-closed loop function (P1.074.X = 1), set DI [0x0B] to On, E-Gear ratio to 1 : 1, and P1.072 to 5000.

To have the motor run a cycle when the full-closed loop function is enabled, the position command has to be 5000.

Example 2: disable the full-closed loop function (P1.074.X = 0), set DI [0x0B] to On, E-Gear ratio to 1 : 1, and P1.072 to 5000.

To have the motor run a cycle when the full-closed loop function is disabled, the position command has to be 16777216 because the DI setting is ineffective and the setting of P1.072 is ignored.

Value: 0x0B			
DI name	Description	Triggering method	Control mode
FHS	Switch between full- and semi-closed loop modes.	Level triggered	PT, PR*

Note: PR full-closed loop function is not yet supported.

6.7.4.9 Z phase source of homing

P2.080	Z phase source of homing		Address: 02A0H 02A1H
Default:	0x0000	Control mode:	PR* (full-closed loop)
Unit:	-	Setting range:	0x0000 - 0x0011
Format:	HEX	Data size:	16-bit

Settings:

The full-closed loop control is realized by connecting the auxiliary encoder to CN5.

When you execute homing and have the servo look for the Z phase, use this parameter to set either the Z phase of the motor or the Z phase of the auxiliary encoder as the homing origin. (Select the auxiliary encoder to achieve higher positioning precision.)

After the full-closed loop function is enabled (P1.074.X = 1), restart and set the Capture function.



X	Z phase source of full-closed loop homing	Z	Reserved
Y	Z phase source of semi-closed loop homing	U	Reserved

- X: Z phase source of full-closed loop homing
  - 0: auxiliary encoder
  - 1: motor
- Y: Z phase source of semi-closed loop homing
  - 0: motor
  - 1: auxiliary encoder

Note: PR full-closed loop function is not yet supported.

## 6.7.4.10 Encoder output settings

<b>P1.003</b>	<b>Encoder pulse output polarity</b>		<b>Address: 0106H 0107H</b>
Default:	0x0000	Control mode:	All
Unit:	-	Setting range:	0x0000 – 0x0013
Format:	HEX	Data size:	16-bit

Settings:

U Z Y X

X	Polarity of monitor analog output	Z	Reserved
Y	Direction of encoder pulse output	U	Reserved

- X: polarity of monitor analog output
  - 0: MON1(+), MON2(+)
  - 1: MON1(+), MON2(-)
  - 2: MON1(-), MON2(+)
  - 3: MON1(-), MON2(-)
- Y: direction of encoder pulse output
  - 0: positive direction
  - 1: negative direction

<b>P1.046 ▲</b>	<b>Encoder pulse number output (OA, OB)</b>		<b>Address: 015CH 015DH</b>
Default:	2500	Control mode:	All
Unit:	pulse	Setting range:	1 - 536870912
Format:	DEC	Data size:	32-bit

Settings:

Rotary motor: the number of single-phase pulse outputs per revolution; the maximum output frequency of the hardware is 19.8 MHz.

Linear motor: the number of single-phase pulse outputs per meter; the maximum output frequency of the hardware is 19.8 MHz.

For the OA and OB settings of CN2 and CN5, refer to P1.074.Y (Selection of OA/OB output source) and P1.097 (Encoder output denominator (OA, OB)).

Note:

In the following circumstances, pulse output of the encoder may exceed the maximum allowable output pulse frequency of the drive, causing AL018 or AL048:

1. Encoder error.
2. The motor speed is faster than P1.076.
3. Rotary motor: if P1.074.Y = 0 and P1.097 = 0, motor speed (rpm)/60 x P1.046 x 4 > 19.8 x 10<sup>6</sup>.  
Linear motor: if P1.074.Y = 1 and P1.097 = 1, motor speed (µm/s) x P1.046 > 19.8 x 10<sup>6</sup>.

<b>P1.076 ▲</b>	<b>Maximum speed for encoder output (OA, OB)</b>		<b>Address: 0198H 0199H</b>
Default:	5500	Control mode:	All
Unit:	1 rpm (rotary)* 10 mm/s (linear)*	Setting range:	0 - 7500 (rotary)* 0 - 15999 (linear)*
Format:	DEC	Data size:	16-bit

Settings:

Please set a value which is slightly higher than the required maximum speed of motor.

Note: rotary means a permanent-magnet synchronous rotary motor; linear means a permanent-magnet synchronous linear motor.

<b>P2.066</b>	<b>Special bit register 2</b>		<b>Address: 0284H 0285H</b>
Default:	0x0030	Control mode:	All
Unit:	-	Setting range:	0x0000 - 0x187F
Format:	HEX	Data size:	16-bit

Settings:

Bit	7	6	5	4	3	2	1	0
Bit	15	14	13	12	11	10	9	8

Bit	Function	Description
Bit 0, Bit 1	Reserved	-
Bit 2	Disable the AL003 (Undervoltage) latch	0: latch enabled; the undervoltage error is not cleared automatically. 1: latch disabled; the undervoltage error is cleared automatically.
Bit 3	Reserved	-
Bit 4	Disable the detection for AL044 (Servo function overload warning)	0: enable the detection. 1: disable the detection.
Bit 5	Enable the detection for AL041 (CN5 is disconnected)	0: disable the detection. 1: enable the detection.
Bit 6	RST power error (AL022) latch	0: disable the latch; RST power error (AL022) is cleared automatically. 1: enable the latch; RST power error (AL022) is not cleared automatically.
Bit 7, Bit 8	Reserved	-
Bit 9	Set AL003 (Undervoltage) as ALM or WARN	0: WARN. 1: ALM.
Bit 10, Bit 11	Reserved	-
Bit 12	Set AL022 (RST power error) as ALM or WARN	0: WARN. 1: ALM.
Bit 13 - Bit 15	Reserved	-

Note: when the full-closed loop function is enabled, the detection for AL041 (CN5 is disconnected) is disabled by default (P2.066 [Bit 5] = 0). It is strongly recommended that you enable this function when the servo is in the full-closed loop mode.

6

6.7.4.11 Full-closed loop feedback source for the controller

<b>P3.013</b>	<b>Controller's full-closed loop feedback</b>		<b>Address: 031AH 031BH</b>
Default:	0x0000	Control mode:	PR* (full-closed loop)
Unit:	-	Setting range:	0x0000 - 0x0022
Format:	HEX	Data size:	16-bit

Settings:



U Z Y X

X	Encoder feedback source in full-closed loop control	Y	Z phase offset source in full-closed loop mode
Z	Reserved	U	Reserved

- X: encoder feedback source in full-closed loop control (the source displayed in the Feedback position [PUU])

  - 0: motor encoder feedback
  - 1: auxiliary encoder feedback
  - 2: in semi-closed loop control, it is the motor encoder feedback; in full-closed loop control, it is the auxiliary encoder feedback.
- Y: Z phase offset source in full-closed loop mode

  - 0: motor
  - 1: auxiliary encoder
  - 2: in semi-closed loop control, it is the motor's Z phase offset; in full-closed loop control, it is the auxiliary encoder's Z phase offset.

Note:

1. This parameter setting is different from P1.074.Y (switch between motor encoder and auxiliary encoder). This parameter only modifies the feedback signal source uploaded to the controller. It is suggested that you set P3.013 to 0x0022 to avoid misoperation when the motor is in the Servo On state.
2. PR full-closed loop function is not yet supported.

## 6.7.5 Troubleshooting full-closed loop alarms

<b>AL040 Excessive position error of full-closed loop control</b>	
Trigger condition and cause	<p>Condition: excessive position error of full-closed loop control.</p> <p>Cause:</p> <ol style="list-style-type: none"> <li>1. The setting value of P1.073 is too low.</li> <li>2. The encoder connector may be loose or there is a problem with the connection between the motor and the mechanical parts.</li> <li>3. The input value for P1.072 can only be an integer. However, when the motor runs a cycle, if the number of A/B pulses in a full-closed loop is not an integer, the position error between the motor encoder and the auxiliary encoder accumulates. Thus, you need to set P1.085 to avoid triggering AL040.</li> </ol>
Checking method and corrective action	<ol style="list-style-type: none"> <li>1. Check the value for P1.073. If the value is too low, set a higher value.</li> <li>2. Make sure the encoder connector is firmly connected and there is no problem with the connection between the motor and the mechanical parts.</li> <li>3. Check if the value of P1.085 is set properly.</li> </ol>
How to clear the alarm?	DI.ARST

<b>AL041 CN5 is disconnected</b>	
Trigger condition and cause	The communication of CN5 is disconnected.
Checking method and corrective action	<ol style="list-style-type: none"> <li>1. Check the communication circuit of CN5.</li> <li>2. When CN5 is not in use, check if both P1.074.X and PM.003.U are set to 0.</li> </ol>
How to clear the alarm?	Cycle power on the servo drive.



(This page is intentionally left blank.)

6

# Motion Control

# 7

This chapter introduces internal motion commands in the ASDA-A3 in PR mode. In this mode, commands are generated based on the internal command of the servo drive. Various motion commands are available, including Homing, Speed, Position, Write, arithmetic operation, and Jump. Other motion control functions such as high-speed position capture (Capture), high-speed position compare (Compare) and E-Cam are also available. This chapter contains detailed description of each command type.

7.1	PR mode description .....	7-3
7.1.1	Shared PR parameters .....	7-5
7.1.2	Monitoring variables of PR mode.....	7-7
7.1.3	Motion Control commands .....	7-10
7.1.3.1	Homing methods.....	7-10
7.1.3.2	Speed command.....	7-23
7.1.3.3	Position command.....	7-25
7.1.3.4	Jump command .....	7-28
7.1.3.5	Write command .....	7-30
7.1.3.6	Rotary Axis Position command (Index).....	7-32
7.1.3.7	Arithmetic operation (Statement) .....	7-36
7.1.4	Overview of the PR procedure .....	7-39
7.1.5	Trigger methods for the PR command .....	7-46
7.1.6	PR procedure execution flow.....	7-50
7.2	Application of motion control .....	7-64
7.2.1	Data array.....	7-64
7.2.2	High-speed position capture function (Capture) .....	7-68
7.2.3	High-speed position compare function (Compare).....	7-72
7.3	E-Cam .....	7-76
7.3.1	Source signal for the master axis .....	7-77
7.3.2	Clutch engagement and disengagement .....	7-81
7.3.3	E-Cam gears and curve scaling .....	7-89
7.3.4	E-Cam curve .....	7-92
7.3.5	E-Cam curve and PR command overlapping.....	7-100
7.3.6	Troubleshooting for E-Cam .....	7-102
7.3.7	Rotary Shear .....	7-104
7.3.8	Flying Shear .....	7-131

7.3.9 Macro.....7-144

7.3.10 Auxiliary function.....7-154

7.3.11 Horizontal packing machine applications .....7-157

# 7

### 7.1 PR mode description

In PR mode, the servo drive automatically generates the motion commands. Apart from the basic arithmetic operation commands, the ASDA-A3 saves all parameter settings in the parameter file in the servo drive. Thus changing parameter values simultaneously changes the PR commands. The ASDA-A3 provides 100 path setting sets, which include the homing method, Position command, Speed command, Jump command, Write command, Rotary Axis Position command, and arithmetic operation commands.

Except for arithmetic operations, the properties and corresponding data for each PR path are set by parameters. You can find information of all PR parameters in the descriptions of Groups 6 and 7 in Chapter 8. For example, PR#1 path is defined by two parameters, P6.002 and P6.003. P6.002 is for specifying the property of PR#1, such as the PR command type, whether to interrupt, and whether to auto-execute the next PR. P6.003 is subject to change based on the properties set in P6.002. If P6.002 is set to a Speed command, then P6.003 specifies the target speed. If P6.002 is set to a Jump command, then P6.003 specifies the target PR. The parameters for the PR#2 path are P6.004 and P6.005, and they work same way as P6.002 and P6.003. The same is true for the rest of PR paths. See Figure 7.1.1.

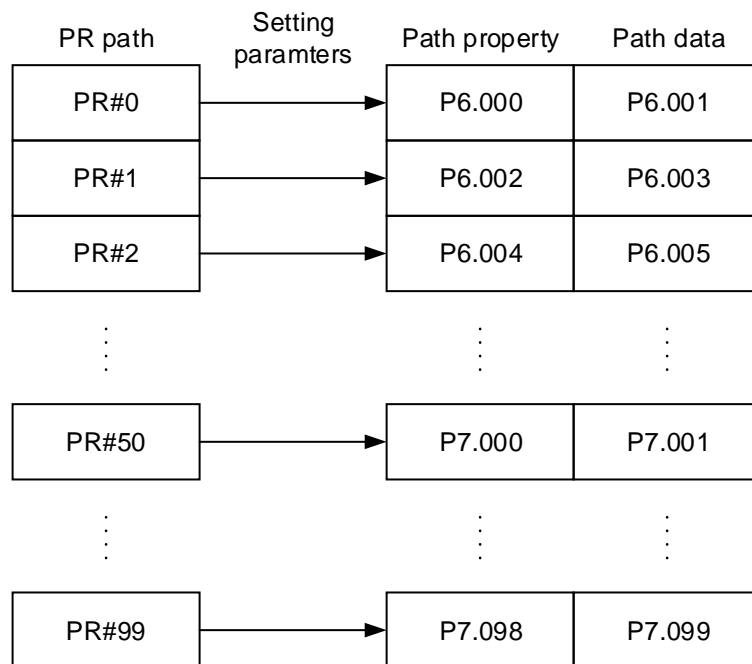

Figure 7.1.1 Setting parameters for each PR path

7

In the ASDA-Soft software, when you select the PR to be edited in PR Mode Setting, the corresponding parameters appear at the top of the window. For example, in Figure 7.1.2, if you select PR#1 , P6.002 and P6.003 appear at the top in the editing section. Table 7.1.1 takes P6.002 and P6.003 for example. The PR property and its data content differ in accordance with the motion command type. For more information about Motion Control mode, refer to Section 7.1.3.

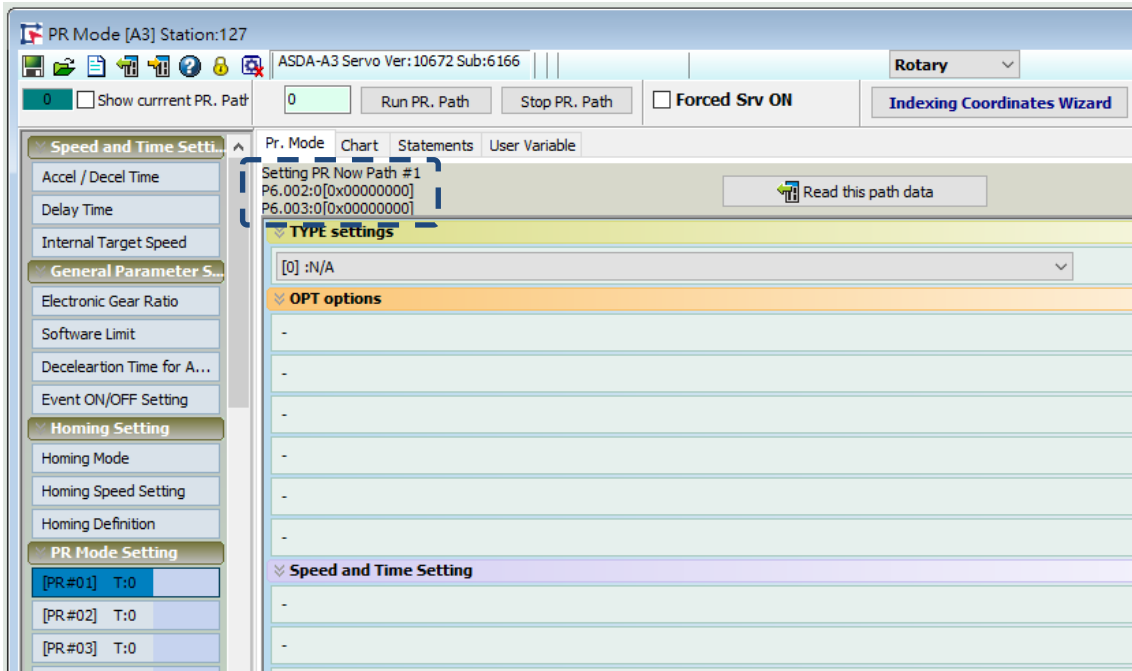

Figure 7.1.2 PR Mode interface in ASDA-Soft

Table 7.1.1 Example of PR#1 property and data content

PR#1 \ Bit	31 - 28	27 - 24	23 - 20	19 - 16	15 - 12	11 - 8	7 - 4	3 - 0
P6.002	-	AUTO	DLY	SPD	DEC	ACC	OPT	TYPE
P6.003	Data content (32-bit)							

Note:

TYPE: Control command mode

TYPE No.	Command mode
1	SPEED: speed control
2	SINGLE: positioning control; stop once positioning is complete.
3	AUTO: positioning control; execute the next PR path once positioning is complete.
7	JUMP: jump to the specified path.
8	WRITE: write parameters to the specified path.
0xA	INDEX: rotary axis position control (index position control)
0x1B	STATEMENT: statement / arithmetic operations

ASDA-Soft version V6 provides an editing interface for PR diagrams. (see Figure 7.1.3). It is easier to set PR paths in ASDA-Soft, where you can set the options of command triggering, command types, and other properties. You must set the arithmetic operations and statements in the software.

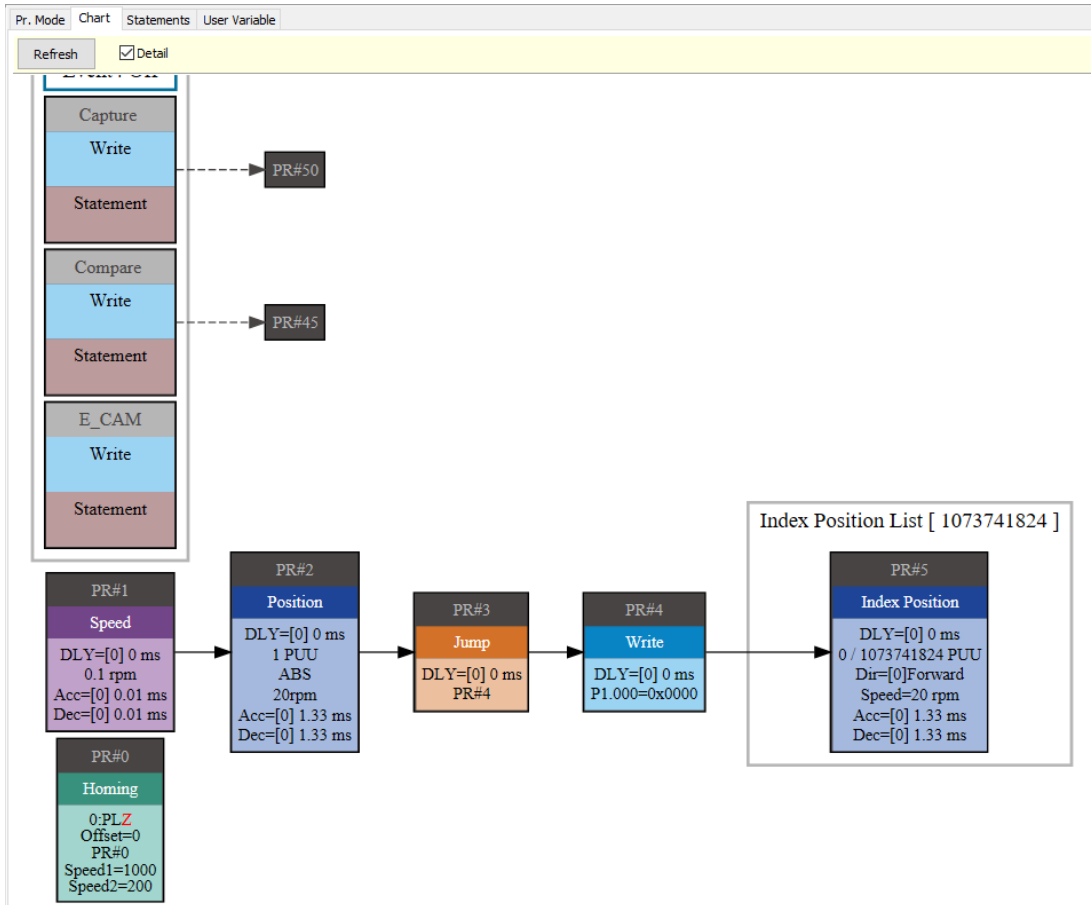

Figure 7.1.3 PR Diagram display in ASDA-Soft

### 7.1.1 Shared PR parameters

ASDA-A3 provides 16 acceleration and deceleration time settings (P5.020 - P5.035), 16 delay time settings (P5.040 - P5.055), and 16 target speed settings (P5.060 - P5.075) for you to set the PR paths (as shown in Figure 7.1.1.1). If you change a parameter that is used by multiple PR paths, then all PR paths using this parameter are changed as well. For example, if multiple PR commands use the target speed setting from P5.060, when you change the value of P5.060, those PR commands' target speed are also changed. Be aware of this when setting PR paths to avoid any danger or damage to the machine. ASDA-Soft also provides a user-friendly interface for this shared PR parameter function (see Figure 7.1.1.2). In these data, the acceleration or deceleration time is set based on the length of time for motor to accelerate from 0 to 3000 rpm or to decelerate from 3000 rpm to 0. For instance, if the acceleration time is set to 50 ms, then the required duration is 50 ms when the target speed for the motion command is 3000 rpm. If the target speed for the motion command is 1500 rpm, then the acceleration time is 25 ms. The

acceleration or deceleration time is a fixed slope, so the slope does not change when you change parameter values.

7

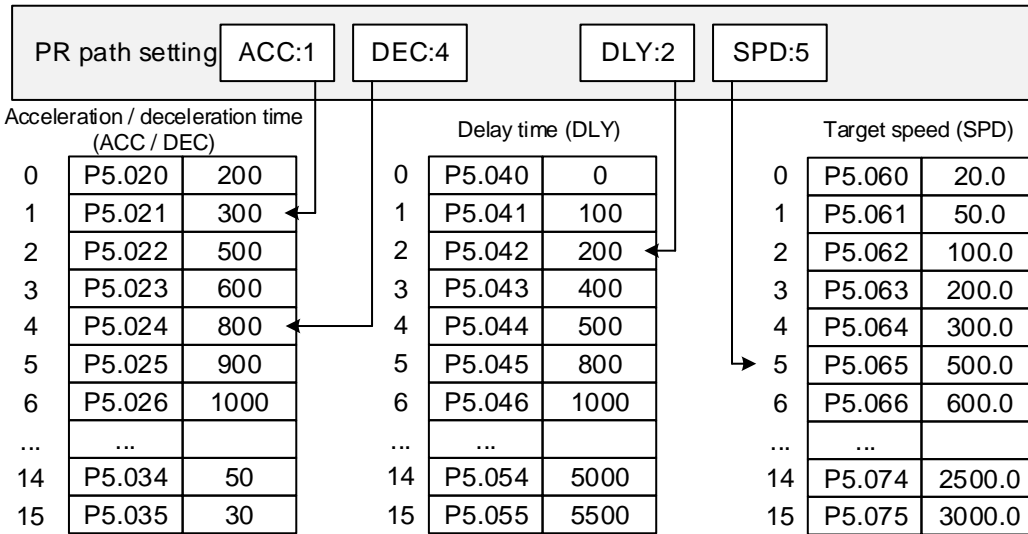

Figure 7.1.1.1 Shared parameter data for PR paths

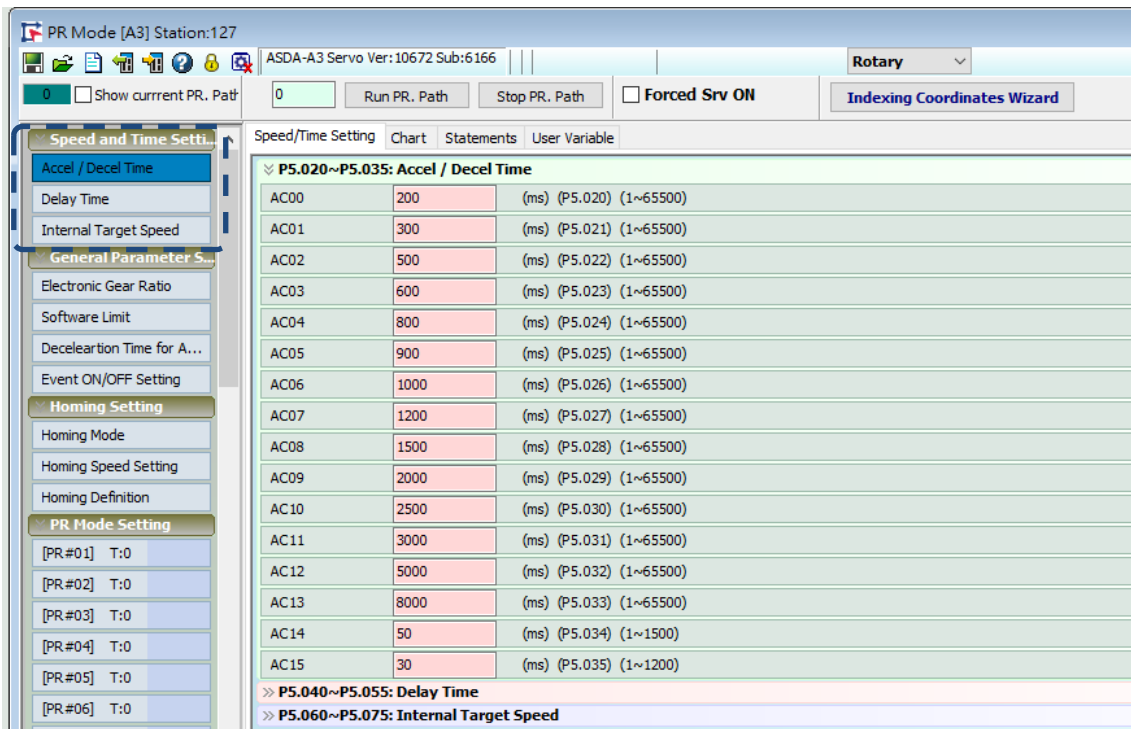

Figure 7.1.1.2 ASDA-Soft interface for shared PR parameter data

### 7.1.2 Monitoring variables of PR mode

The PR mode provides four monitoring variables for the servo command and feedback: command position (PUU), PR command end register, feedback position (PUU), and position error (PUU). These are described as follows:

1. Command position (PUU): monitoring variable code 001. The target position of the motion command generated per scan cycle during servo operation (updated every 1 ms), simplified as Cmd\_O (Command Operation).
2. PR command end register: monitoring variable code 064. The target position of the PR command, simplified as Cmd\_E (Command End). When a command is triggered, the servo drive calculates the target position and then updates to PR command end register.
3. Feedback position (PUU): monitoring variable code 000. The encoder feedback position (coordinates), simplified as Fb\_PUU (Feedback PUU).
4. Position error (PUU): monitoring variable code 002. The deviation between the command position (PUU) and the feedback position (PUU), simplified as Err\_PUU (Error PUU).

How these four monitoring variables work is shown in Figure 7.1.2.1. After the servo issues a Position command, the servo sets the position of Cmd\_E once the target position data is acquired. The motor operates to the target position based on the PR path setting. Cmd\_O calculates the amount of command deviation in each fixed cycle and sends it to the servo drive, where it is treated as a dynamic command. Fb\_PUU is encoder feedback position and Err\_PUU is the deviation of Cmd\_O minus Fb\_PUU.

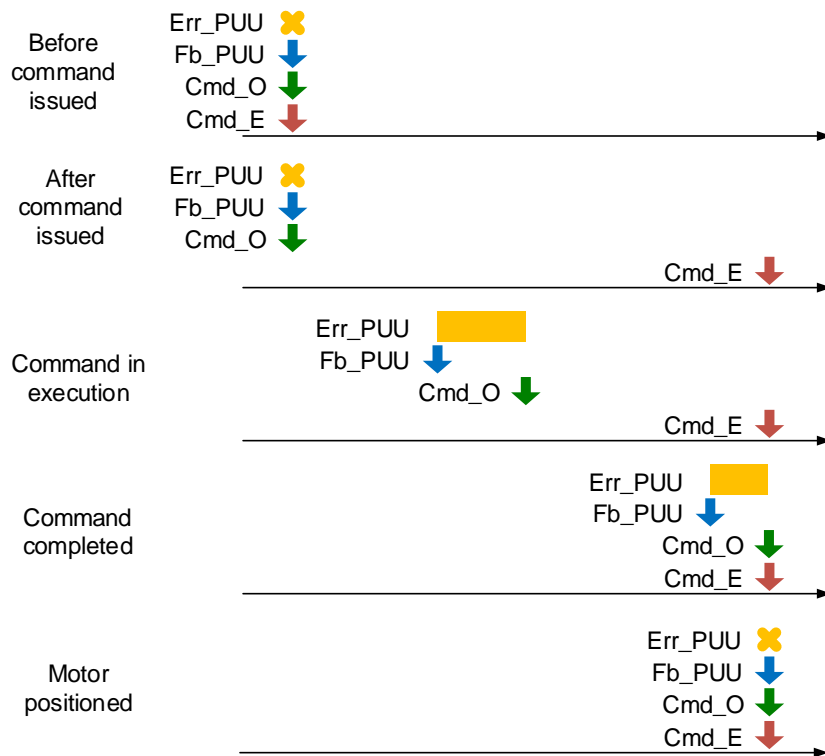

Figure 7.1.2.1 Timing diagram for PR mode monitoring variables



## 7

The detailed command behavior of each stage is illustrated in Figure 7.1.2.2. Cmd\_E is the endpoint specified by the command; it is set when the PR path is triggered. Fb\_PUU is the feedback position, which is motor's actual position. Divide this motion command into slices and take one of them as example. Cmd\_O is the target of this cycle command and Err\_PUU is the deviation between the target position of the cycle command and the feedback position.

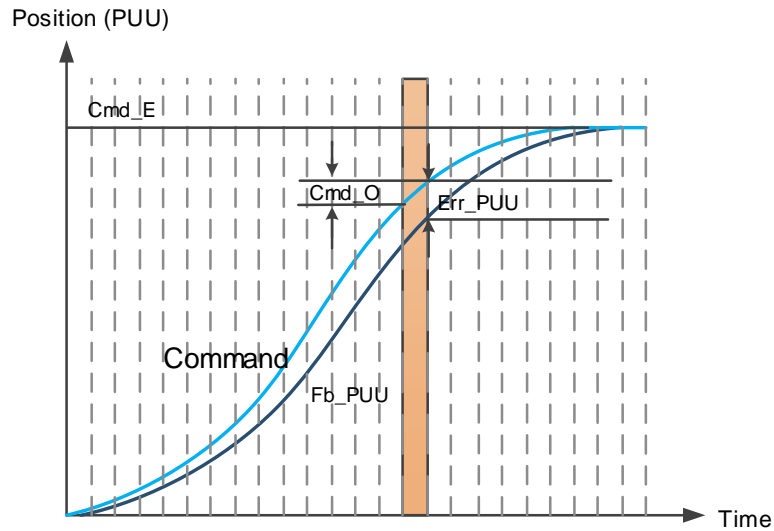

Figure 7.1.2.2 Monitoring variables status when a command is executed in PR mode

You can use the digital input (DI) to call and the digital output (DO) to monitor PR paths (refer to Table 8.1 and 8.2 for DI/O function descriptions). When you trigger the motion command with DI.CTRG [0x08], the servo operates based on the command from the internal registers. Once the execution is complete, DO.Cmd\_OK [0x15] (PR Position command complete) is set to on. When the position deviation (pulse number) becomes smaller than the value of P1.054, DO.TPOS [0x05] (Motor reaches the target position) is set to on. Then, both DO signals are on and the servo outputs the MC\_OK [0x17] signal to signify that it has completed this PR path. The operation is as shown in Figure 7.1.2.3. If you have set a delay time in this PR and the position deviation (pulse number) is smaller than the value of P1.054, DO.TPOS [0x05] is set to on.

When the delay time is over, DO.Cmd\_OK [0x15] (PR position command complete) is set to on. After both DO.TPOS and DO.Cmd\_OK are on, DO.MC\_OK [0x17] (Servo procedure complete) is set to on to signify it has completed this PR path, as shown in Figure 7.1.2.4.

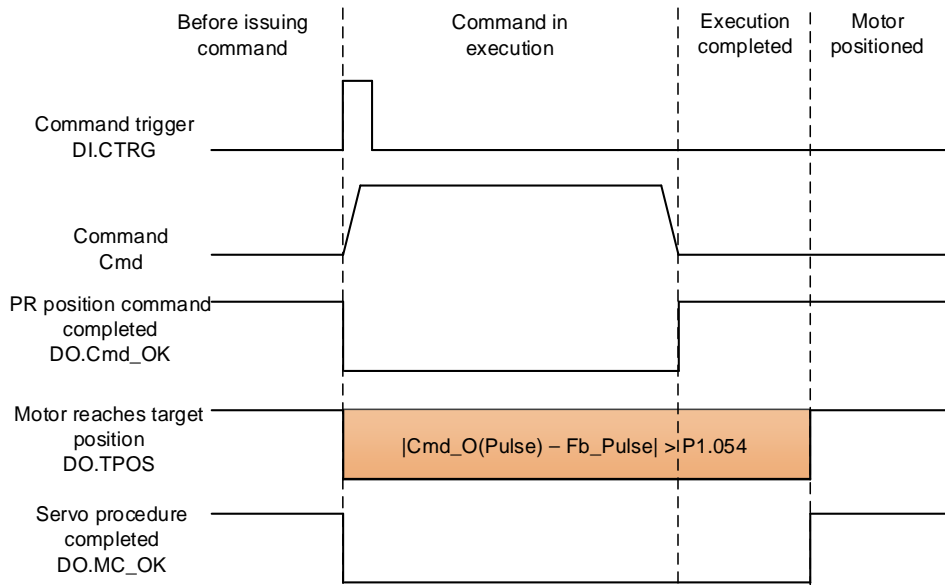

Figure 7.1.2.3 Operation of DI/DO signals in PR mode

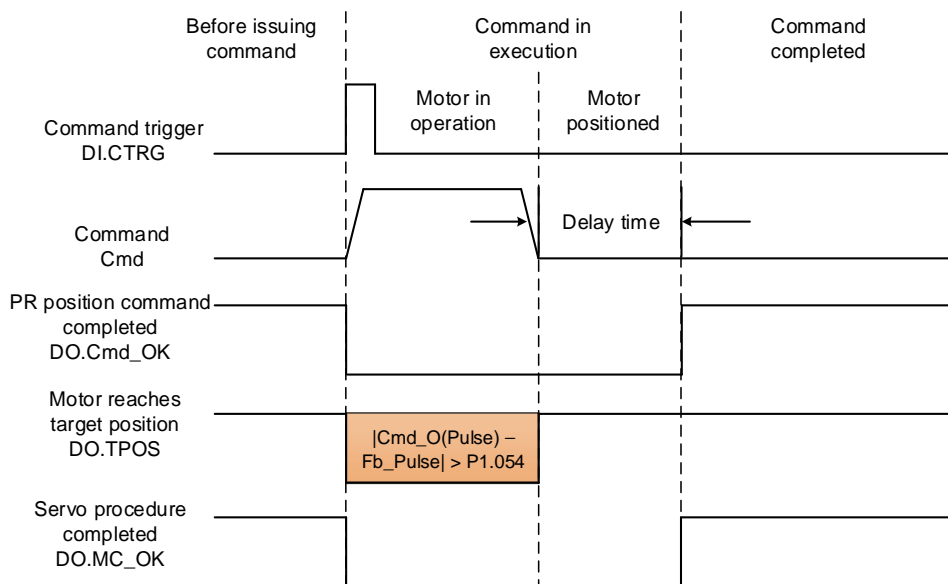

Figure 7.1.2.4 Operation of DI/DO signals in PR mode (including delay time)

# 7

## 7.1.3 Motion Control commands

The ASDA-A3 provides 100 path sets. Apart from the fixed homing command, you can respectively set the speed, position, path jumping, parameter writing, rotary axis position, and arithmetic operation commands. The following sections detail each command type.

### 7.1.3.1 Homing methods

The ASDA-A3 provides 11 homing methods in the PR mode, including home sensor, limit, and hard stop as the reference origin. They come with sub-selections such as whether to refer to the Z pulse and the limit signal as the trigger, with more than 30 combinations available. The homing method is specified by P5.004 and the homing definition is determined by P6.000. The function of each bit is listed as follows.

P5.004	Homing methods		Address: 0508H 0509H
Default:	0x0000	Control mode:	PR
Unit:	-	Setting range:	0x0000 - 0x12A
Format:	HEX	Data size:	16-bit

Settings:



X	Homing method	Z	Limit setting
Y	Z pulse setting	U	Reserved

Definition of each setting value:

U	Z	Y	X
Reserved	Limit setting 0 to 1	Z pulse setting 0 to 2	Homing method 0 to A
-	-	Y = 0: return to Z pulse Y = 1: go forward to Z pulse Y = 2: do not look for Z pulse	X = 0: homing in forward direction and define the positive limit as the homing origin
			X = 1: homing in reverse direction and define the negative limit as the homing origin
-	When reaching the limit: Z = 0: show error Z = 1: reverse direction	-	X = 2: homing in forward direction, ORG: OFF→ON as the homing origin
			X = 3: homing in reverse direction, ORG: OFF→ON as the homing origin
			X = 4: look for Z pulse in forward direction and define it as the homing origin
			X = 5: look for Z pulse in reverse direction and define it as the homing origin

U	Z	Y	X
		Y = 0: return to Z pulse Y = 1: go forward to Z pulse Y = 2: do not look for Z pulse	X = 6: homing in forward direction, ORG: ON→OFF as the homing origin X = 7: homing in reverse direction, ORG: ON→OFF as the homing origin
	-	-	X = 8: define the current position as the origin
	When reaching the limit: Z = 0: show error Z = 1: reverse direction	Y = 0: return to Z pulse Y = 2: do not look for Z pulse	X = 9: torque homing in forward direction X = A: torque homing in reverse direction

P6.000	Homing definition		Address: 0600H 0601H
Default:	0x00000000	Control mode:	PR
Unit:	-	Setting range:	0x00000000 - 0xFFFFFFFF6F
Format:	HEX	Data size:	32-bit

Settings:

Homing definition:



A	DEC2: deceleration time selection for second homing	YX	PATH: path type
B	DLY: select 0 - F for delay time	Z	ACC: select 0 - F for acceleration time
C	Reserved	U	DEC1: deceleration time selection for first homing
D	BOOT: whether to execute homing automatically when the drive is powered on	-	-

- YX: PATH: path type  
0x00: Stop: the servo stops after homing is complete  
0x01 - 0x63: Auto: the servo executes the specified path (Path 1 - Path 99) after homing is complete
- Z: ACC: select 0 - F for acceleration time  
0 - F: correspond to P5.020 - P5.035
- U: DEC1: deceleration time selection for first homing  
0 - F: correspond to P5.020 - P5.035
- A: DEC2: deceleration time selection for second homing  
0 - F: correspond to P5.020 - P5.035
- B: DLY: select 0 - F for delay time  
0 - F: correspond to P5.040 - P5.055
- D: BOOT: whether to execute homing automatically when the drive is powered on  
0: do not execute homing  
1: execute homing automatically (servo switches to on for the first time after power is applied)

7

The PR Homing mode includes the function for setting the origin offset. You can define any point on the coordinate axis as the reference origin, which does not have to be 0. Once you define the reference origin, the system can create the coordinate system for the motion axis. See Figure 7.1.3.1.1. The coordinate of the reference origin is 2000 (P6.001 = 2000). The motor passes by the reference origin and then stops at coordinate 1477. From the coordinate system that it created, the system automatically calculates the position of 0 point. As soon as the PR motion command is issued, the motor moves to the specified position.

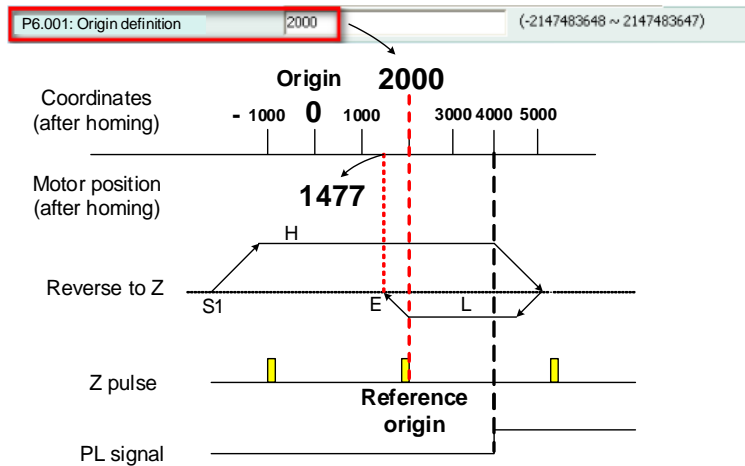

Figure 7.1.3.1.1 Origin definition

P6.001	Origin definition	Address: 0602H 0603H	
Default:	0	Control mode:	PR
Unit:	-	Setting range:	-2147483648 to +2147483647
Format:	DEC	Data size:	32-bit

Settings:

Origin definition.

The servo starts the homing procedure at high speed to seek the reference point (such as the limit switch and ORG signal), which takes shorter time. Once the servo detects the reference point, the motor runs at low speed to find the reference point accurately (such as the Z pulse). The speeds for the two stages are defined by P5.005 and P5.006.

P5.005	High speed homing (first speed setting)			Address: 050AH 050BH
Operation interface:	Panel / software	Communication	Control mode:	PR (set with P5.004)
Default:	100.0 (rotary)* 1000 (linear)*	1000	Data size:	32-bit
Unit:	1 rpm (rotary)* 1 μm/s (linear)*	0.1 rpm (rotary)* 1 μm/s (linear)*		
Setting range:	0.1 to 2000.0 (rotary)* 1 to 15999999 (linear)*	1 to 20000 (rotary)* 1 to 15999999 (linear)*		
Format:	DEC	DEC	-	-
Example:	1.5 = 1.5 rpm 15 = 15 μm/s	15 = 1.5 rpm 15 = 15 μm/s	-	-

Settings:

The first speed setting for high speed homing.

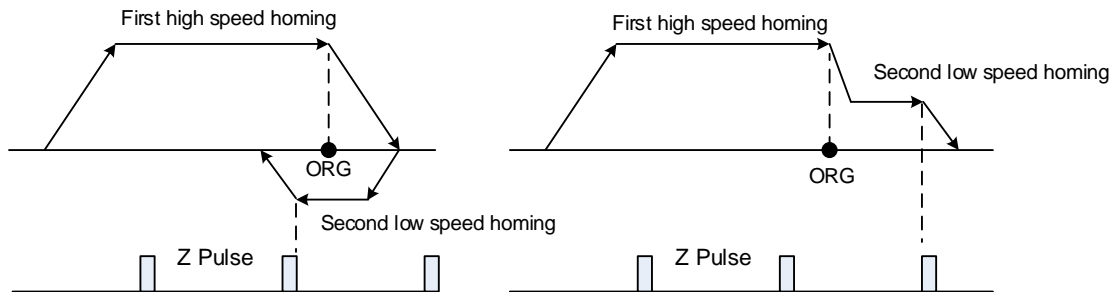

Note: rotary means a permanent-magnet synchronous rotary motor; linear means a permanent-magnet synchronous linear motor.

P5.006	Low speed homing (second speed setting)			Address: 050CH 050DH
Operation interface:	Panel / software	Communication	Control mode:	PR (set with P5.004)
Default:	20.0 (rotary)* 200 (linear)*	200	Data size:	32-bit
Unit:	1 rpm (rotary)* 1 μm/s (linear)*	0.1 rpm (rotary)* 1 μm/s (linear)*		
Setting range:	0.1 to 500.0 (rotary)* 1 to 15999999 (linear)*	1 to 5000 (rotary)* 1 to 15999999 (linear)*		
Format:	DEC	DEC	-	-
Example:	1.5 = 1.5 rpm 15 = 15 μm/s	15 = 1.5 rpm 15 = 15 μm/s	-	-

Settings:

The second speed setting for low speed homing.

Note: rotary means a permanent-magnet synchronous rotary motor; linear means a permanent-magnet synchronous linear motor.

In PR mode homing screen in ASDA-Soft, you can set the homing parameters, including the homing methods, homing definition, and homing speed (see Figure 7.1.3.1.2).

7

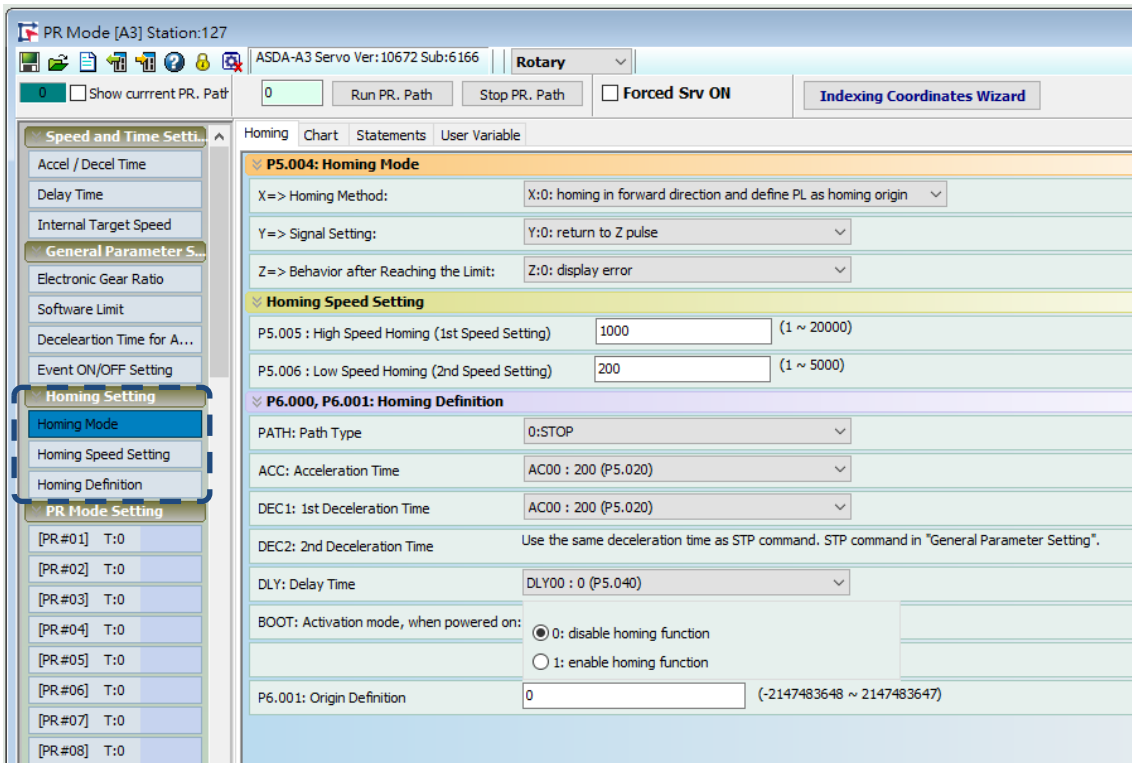
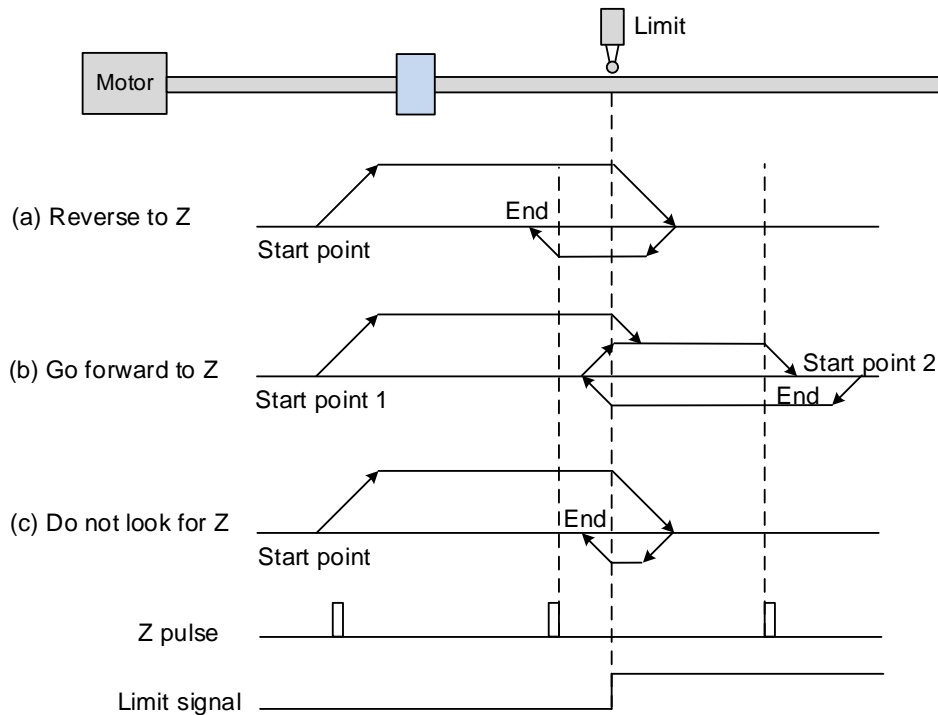

Figure 7.1.3.1.2 Homing screen in ASDA-Soft

The following describes the homing methods supported by the ASDA-A3. They can be categorized into six types based on their reference points.

## 1. Referencing the limit.

This homing method uses the positive or negative limit as the reference point. When the limit is detected, you can choose whether to look for the Z pulse and use it as the reference origin. The searching result is the same regardless of where the start point is. The ASDA-A3 always looks for the reference point according to the setting to correctly reset the coordinates.



Refer to the preceding figure for examples.

- If you set the servo to look for the Z pulse in the reverse direction, the servo operates at high speed (first speed setting) and then decelerates once it reaches the limit (rising-edge triggered). Then the servo switches to low speed (second speed setting) to look for the Z pulse in the reverse direction. When the servo finds the Z pulse, it decelerates to a stop, completing the homing procedure.
- If you set the servo to look for the Z pulse in the forward direction and the limit signal at the start position is un-triggered (low, Start point 1), the servo operates at high speed (first speed setting) and then decelerates once it reaches the limit (rising-edge triggered). Then the servo switches to low speed (second speed setting) to look for the Z pulse in the forward direction. When the servo finds the Z pulse, it decelerates to a stop, completing the homing procedure. If you set the servo to look for the Z pulse in the forward direction and the limit signal at the start position is triggered (high, Start point 2), the servo returns to look for the rising-edge limit signal at low speed (second speed setting). Once it is found, the servo starts to look for the Z pulse and decelerates to a stop when it finds the Z pulse, completing the homing procedure. In conclusion, the origin is at the same position after homing with the same condition regardless of the location of the start point.



# 7

- (c) If you set the servo to not look for the Z pulse, the servo first operates at high speed (first speed setting) and then decelerates to a stop once the rising-edge limit signal is triggered. Then the servo switches to low speed (second speed setting) to look for the rising-edge signal. Once it finds the rising-edge signal, the servo decelerates to a stop, completing the homing procedure.

2. Referencing the rising-edge of the ORG signal.

This method uses the rising-edge signal of the home sensor as the reference origin. You can choose whether to use Z pulse as the reference origin after the ORG signal is detected.

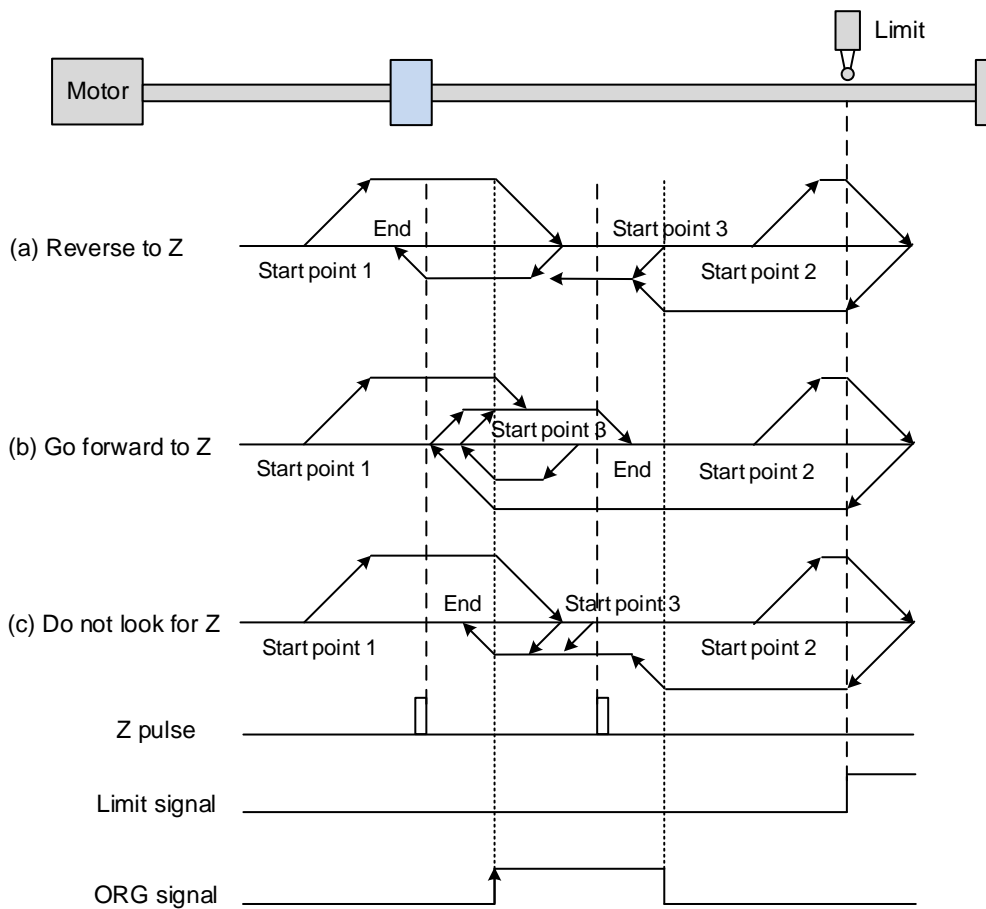

Refer to the preceding figure for examples.

- (a) If you set the servo to look for the Z pulse in the reverse direction, when the ORG signal at the start point is un-triggered (low, Start point 1), the servo operates at high speed (first speed setting) until reaching the rising-edge of ORG signal. Then it decelerates, switches to low speed (second speed setting) until the ORG signal switches to low, and starts looking for the Z pulse in the reverse direction. When the servo finds the Z pulse, it decelerates to a stop, completing the homing procedure.

- (b) If the ORG signal at the start point is un-triggered and the current position is relatively closer to the limit switch (Start point 2), the servo operates at high speed (first speed setting) until reaching the limit switch. You can set whether to show an error or reverse the operating direction when it reaches the limit switch. If you set the servo to reverse direction, it operates in the reverse direction to reach the home sensor (ORG). Once reaching the home sensor (ORG), the servo decelerates and operates at low speed (second speed setting) until the ORG signal switches to low. Next, the servo starts to look for the Z pulse. When the servo finds the Z pulse, it decelerates to a stop, completing the homing procedure.
- (c) If the ORG signal at the start point is triggered (high, Start point 3), the servo reverses with low speed (second speed setting) and after the ORG signal switches to low, it continues to look for the Z pulse. Once the servo finds the Z pulse, it decelerates to a stop, completing the homing procedure.
- (d) If you set the servo to look for the Z pulse in the forward direction or not to look for the Z pulse (this is similar to the first method (a) mentioned earlier), refer to the preceding timing diagram.

### 3. Referencing the Z pulse.

This method uses the Z pulse as the reference origin. One Z pulse is generated per motor revolution. This method is only suitable when the operation is kept within one motor revolution.

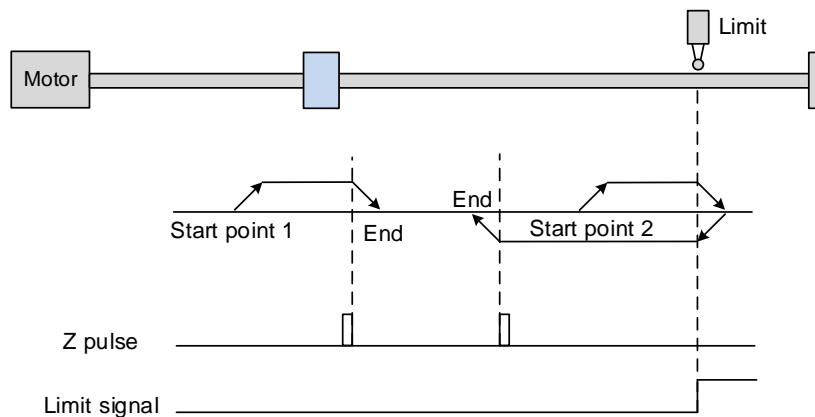

4. Referencing the falling-edge of the ORG signal.

This method uses the falling-edge signal of the home sensor as the reference origin. You can choose whether to use the Z pulse as the reference origin after the ORG signal is detected.

7

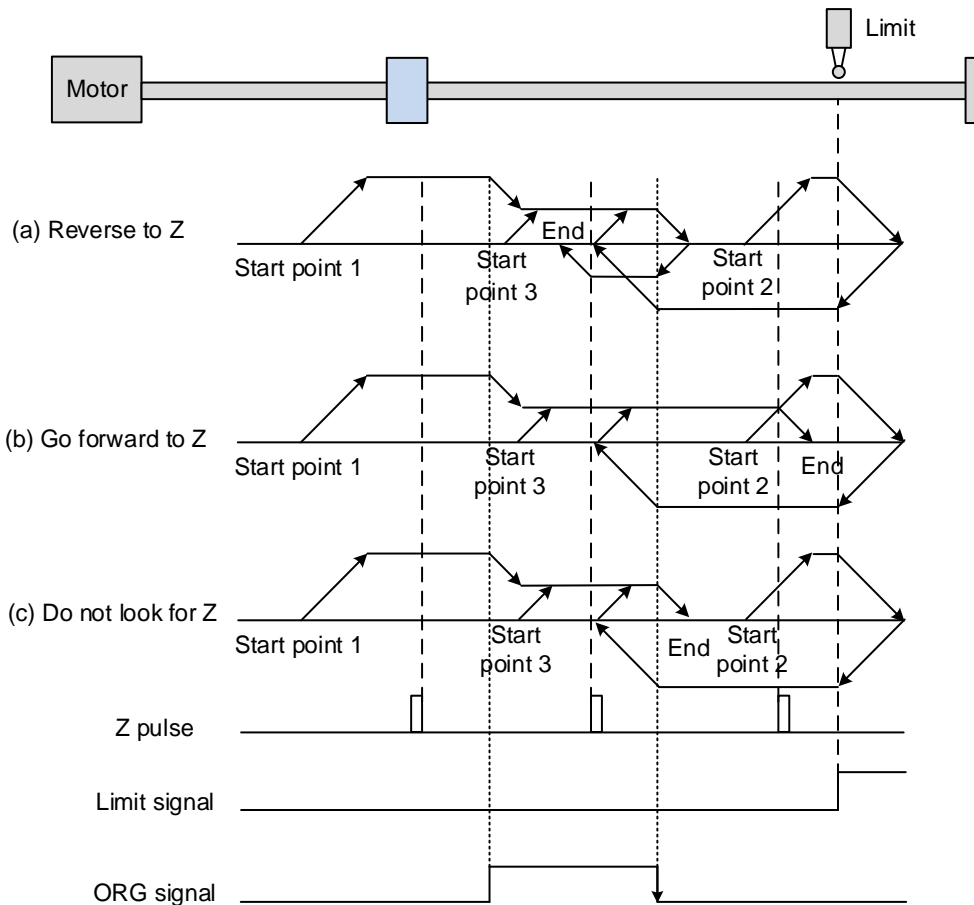

Refer to the preceding figure for examples.

- (a) If you set the servo to look for the Z pulse in the reverse direction, when the ORG signal at the start point is un-triggered (low, Start point 1), the servo operates at high speed (first speed setting) until reaching the rising edge of the ORG signal. Then it decelerates and switches to low speed (second speed setting) until reaching the falling edge of the ORG signal. Next, the servo reverses to look for the Z pulse. When the servo finds the Z pulse, it decelerates to a stop, completing the homing procedure.

- (b) If the ORG signal at the start point is un-triggered and the current position is relatively closer to the limit switch (Start point 2), the servo operates at high speed (first speed setting) until reaching the limit switch. You can set whether to show an error or reverse the operating direction when it reaches the limit switch. If you set the servo to reverse direction, it operates in reverse direction to reach the home sensor (ORG). Once reaching the home sensor (ORG), the servo decelerates and operates at low speed (second speed setting) in the forward direction to reach the falling edge of the ORG signal. Next, the servo reverses to look for the Z pulse. When the servo finds the Z pulse, it decelerates to a stop, completing the homing procedure.
- (c) If the ORG signal at the start point is triggered (high, Start point 3), the servo operates at low speed (second speed setting) in the forward direction until the ORG signal switches to low. Next, the servo reverses to look for the Z pulse. When the servo finds the Z pulse, it decelerates to a stop, completing the homing procedure.
- (d) If you set the servo to look for the Z pulse in the forward direction or not to look for the Z pulse (this is similar to the first method (a) mentioned earlier), refer to the preceding timing diagram.
5. Referencing the current position as the origin.

This method uses the motor's current position as the reference origin. As long as the homing procedure is triggered and the motor remains still, then coordinate positioning is complete.

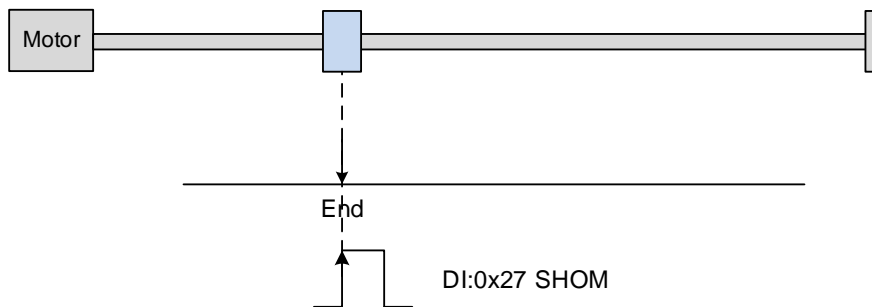

## 6. Referencing the torque limit.

This method uses the motor's stop position as the origin by referring to: the limit on the mechanical parts, the torque level detection (P1.087), and the level reached timer (P1.088). You can also choose whether to use the Z pulse as the origin.

## 7

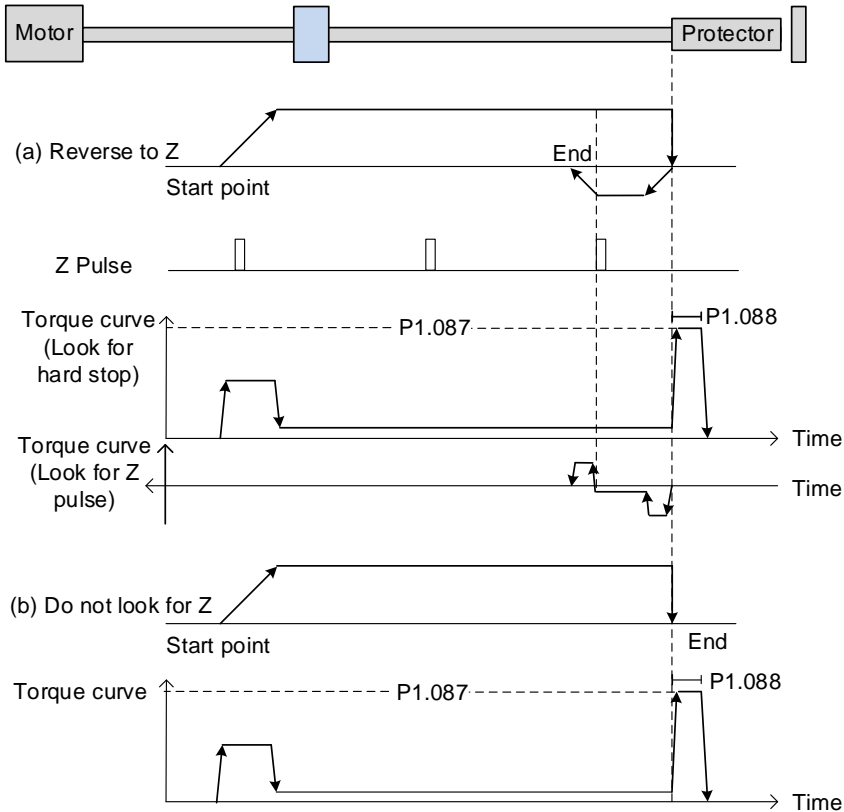

Refer to the preceding figure for examples.

- If you set the servo to look for the Z pulse in the reverse direction, the servo operates at high speed (first speed setting) and outputs a greater current to counter the external force once it touches the protector. When the motor torque reaches the torque detection level (P1.087) and the output duration is longer than the level reached timer setting (P1.088), the servo operates in the reverse direction to look for the Z pulse at low speed (second speed setting). Once the servo finds the Z pulse, it decelerates to a stop, completing the homing procedure.
- If you set the servo not to look for the Z pulse, the servo operates at high speed (first speed setting) until it touches the protector. Then the servo outputs a greater current to counter the external force. When the motor torque reaches the torque detection level (P1.087) and the output duration is longer than the level reached timer setting (P1.088), the servo stops, completing the homing procedure.

Pay special attention when executing the Torque homing procedure. The motor's actual maximum torque output is 10% greater than the maximum torque limit setting (P1.087), and the great impact may cause damage to the machine.

The settings and descriptions for the torque level detection (P1.087) and level reached timer (P1.088) are as follows.

P1.087	Torque homing - torque level detection		Address: 01AEH 01AFH
Default:	1	Control mode:	PR
Unit:	%	Setting range:	1 - 300
Format:	DEC	Data size:	16-bit

Settings:

This setting is only for the torque homing mode. As shown in the following figure, after homing is triggered, the motor runs in one direction and the mechanical part reaches the protector. The servo drive then outputs a larger motor current in order to counter the external force. The servo drive uses P1.087 and P1.088 as the conditions for homing. Since the hard stops are not always the same, it is recommended that you have the servo return to return to find the Z pulse as the origin.

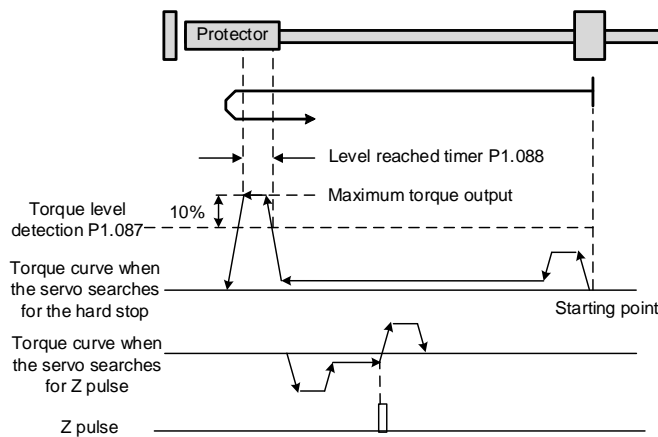

Note: the actual maximum torque output of the motor is 10% greater than the detected torque level (P1.087). For example: set P1.087 to 50%, then the maximum torque output of the motor is 60%.

P1.088	Torque homing - level reached timer		Address: 01B0H 01B1H
Default:	2000	Control mode:	PR
Unit:	ms	Setting range:	2 to 2000
Format:	DEC	Data size:	16-bit

Settings:

The setting of the **torque level reached timer** for the torque homing mode. If the motor torque output continues to exceed the level set by P1.087 and the duration exceeds this setting, the homing is complete. Refer to P1.087 for the timing diagram of torque homing mode.

7

As mentioned in Section 7.1.2, the PR mode provides four monitoring variables for you to monitor the servo commands and feedback status. These are Command position PUU (Cmd\_O), PR command end register (Cmd\_E), Feedback position PUU (Fb\_PUU), and Position error PUU (Err\_PUU). Before homing completes, the command end register (Cmd\_E) cannot be calculated because the coordinate system can only be created after homing is complete, and the target position remains unknown after the Homing command is issued. This is why the status of each monitoring variable is different during homing. In Homing command's default setting, the contents of Cmd\_E and Cmd\_O are identical. After the servo finds the reference origin and creates the coordinate system, it sets the content of Cmd\_E to the coordinate of the reference origin. However, once it finds the reference origin, it still requires some distance for motor to decelerate to a stop. Meanwhile, Cmd\_O continues to issue commands. If no other PR commands are issued after homing (other than the Position command), the contents of the final command position (Cmd\_O) and command end position (Cmd\_E) will be different. See Figure 7.1.3.1.3.

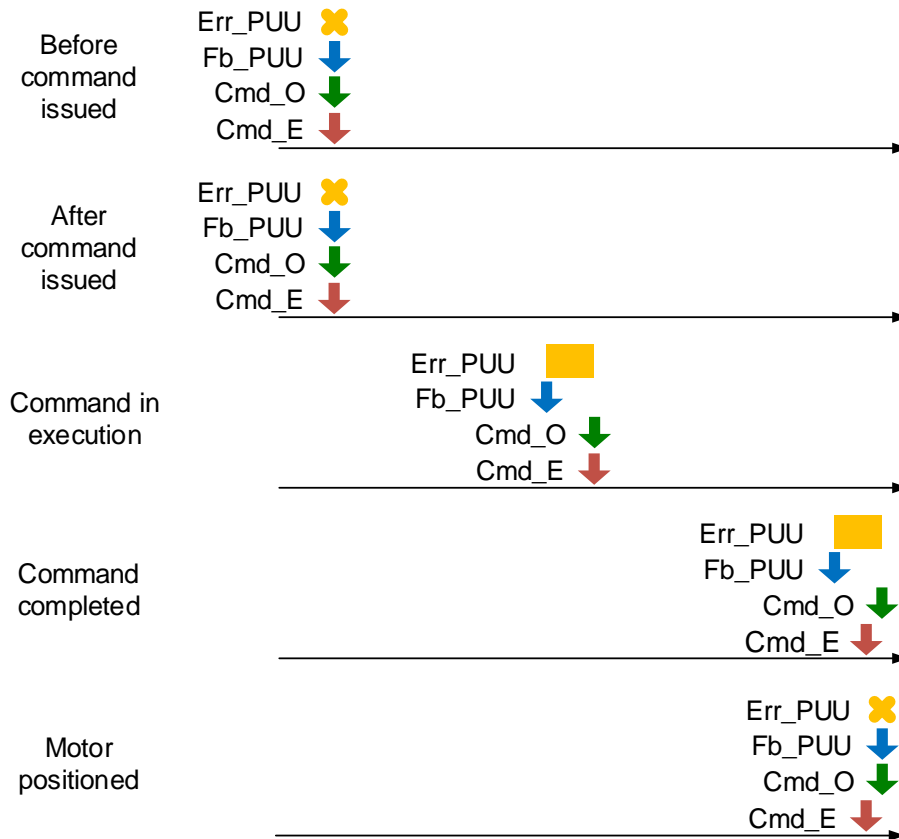

Figure 7.1.3.1.3 Homing mode and monitoring variables

### 7.1.3.2 Speed command

The PR mode includes a speed control function. The following parameters are available for PR speed setting: acceleration / deceleration time, delay time, and target speed. You can easily set the Speed command in the PR mode screen in ASDA-Soft. See Figure 7.1.3.2.1.

- INS is an interrupt command that interrupts the previous motion command. Refer to Section 7.1.6 for more details.
- AUTO is a command that automatically loads and executes the next PR path when the current PR path completes. In addition, you can set the target speed with two unit options, which are 0.1 rpm and 1 PPS, and the setting range is -6000 rpm to 6000 rpm.
- ACC / DEC is the acceleration / deceleration time determined by the shared PR parameters. The software calculates and displays the required duration for accelerating from 0 to the target speed.
- DLY is the delay time determined by the shared PR parameters. It delays the command; in other words, the delay time is the time to wait after the target speed command completes.

See Figure 7.1.3.2.2 for the effects of the parameters for the PR mode speed control. Table 7.1.3.2.1 shows the bit functions when speed control is in operation.

The screenshot displays the ASDA-Soft PR mode Speed screen. It is organized into several sections:

- TYPE settings:** A dropdown menu showing "[1] :Constant speed control".
- OPT options:**
  - INS: Interrupt the previous PR path when executing the current PR path:  0:NO  1:YES
  - AUTO: Automatically load the next PR path when current PR completes:  0:NO  1:YES
  - UNIT: Unit:  0.1 rpm  1: PPS (PUU per sec)
- Speed and Time Setting:**
  - ACC: Time for accelerating to the rated speed (3000 rpm) | AC00 : 200 (P5.020) | Time=6.667 ms
  - DEC: Time for decelerating from the rated speed (3000 rpm) | AC00 : 200 (P5.020) | Time=6.667 ms
  - DLY: Delay Time | DLY00 : 0 (P5.040)
- Data:** Target Speed: 1000 (-60000 ~ 60000)
- Comment:** Add note here!
- Buttons:** Download, Download All PR

Figure 7.1.3.2.1 PR mode Speed screen in ASDA-Soft



7

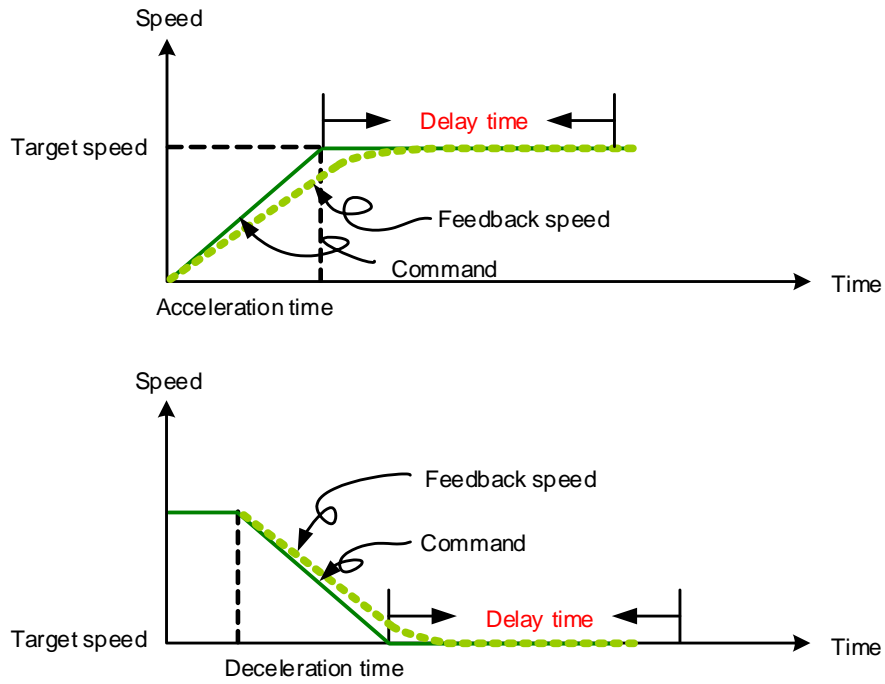

Figure 7.1.3.2.2 Parameters for PR mode speed control

Table 7.1.3.2.1 Bit function of PR speed control

PR parameters	D	C	B	A	U	Z	Y	X
Command type	-	-	DLY	-	DEC	ACC	OPT	1
Data Content	Target speed [0.1 rpm / PPS]							

Note:

1. Y: OPT: option

BIT	3	2	1	0
Command type	-	UNIT	AUTO	INS

INS: interrupt command that interrupts the previous motion command.

AUTO: automatically loads the next PR command when the current one is complete.

UNIT: speed unit selection; 0 signifies 0.1 rpm and 1 signifies PPS.

2. Z, U: ACC / DEC: acceleration / deceleration time, set by P5.020 - P5.035.

3. B: DLY: delay time, set by P5.040 - P5.055.

### 7.1.3.3 Position command

The PR mode includes a position control function. There are two command types: Mode 2 and Mode 3. In Mode 2 the command signifies that it stops once the command is complete. In Mode 3 the command signifies that the next PR path is automatically executed. You use the same method to set the value for these modes in ASDA-Soft. See Figure 7.1.3.3.1.

- INS is an interrupt command that interrupts the previous motion command.
- OVLP is an overlap command that allows the next PR command to overlap the current command which is decelerating. If you use this function, setting the delay time to 0 is suggested (refer to Section 7.1.6).
- ACC / DEC is the acceleration / deceleration time determined by the shared PR parameters. The software calculates and displays the required duration for accelerating from 0 to the target speed.
- SPD is the target speed specified by the shared PR parameters. You can choose whether it is multiplied by 0.1.
- DLY is the delay time specified by the shared PR parameters and it is defined by the command from the controller; in other words, once the target position is reached, the servo drive starts counting the delay time. The Position command is user-defined and its unit is PUU.

See Figure 7.1.3.3.2 for the effects of the parameters for the PR mode position control. Table 7.1.3.3.1 shows the bit function when position control is in operation.

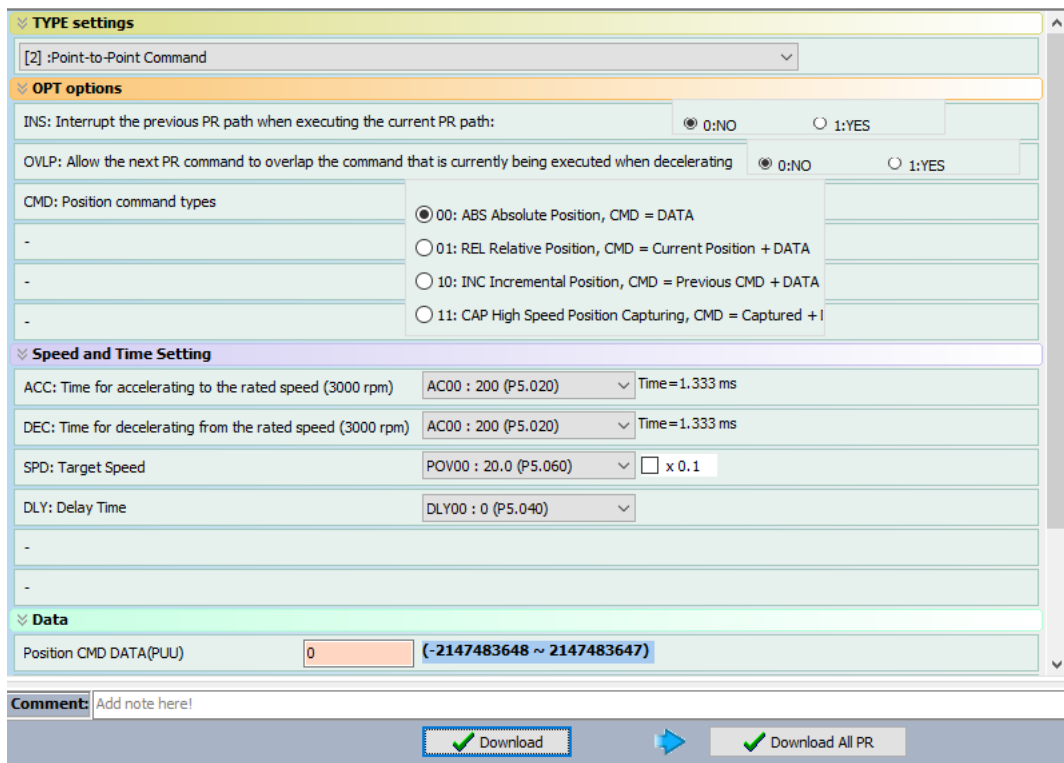

Figure 7.1.3.3.1 PR mode Position control screen in ASDA-Soft

## 7

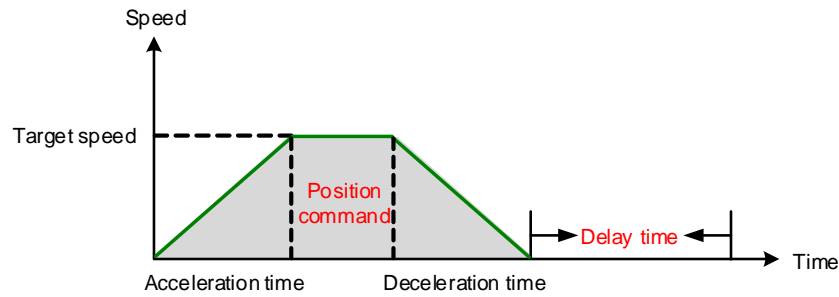
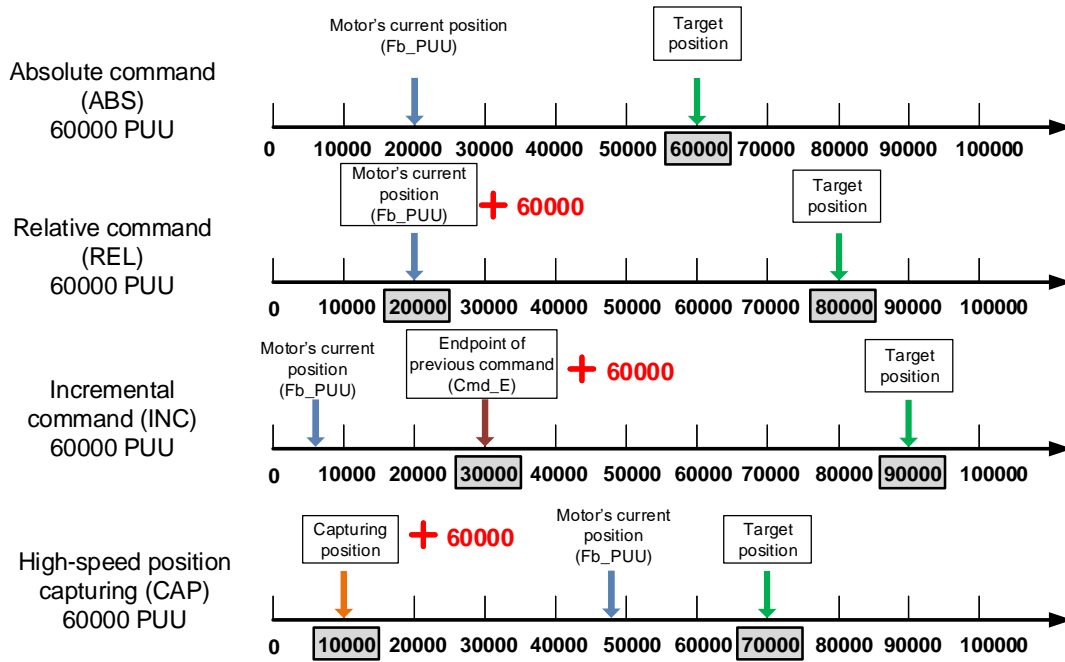

Figure 7.1.3.3.2 Parameters for PR mode position setting

There are four types of position commands for the PR mode. You can choose the position command according to the application requirements. The functions of each type are described in the following examples. Note that the condition in these examples is that a position command is still being executed and another type of command is inserted. To see the definition of each command and how the position commands are combined, refer to Figure 7.1.3.3.3.

1. Absolute position command (ABS): when ABS command is executed, the target position value equals the absolute command value. In the following example, an ABS command with the value of 60000 PUU is inserted in the previous PR path with setting target position of 60000 PUU on the coordinate axis.
2. Relative position command (REL): when REL command is executed, the target position value is the motor's current position value plus the position command value. In the following example, a REL command with the value of 60000 PUU is inserted in the previous PR path. The target position is the motor's current position (20000 PUU) plus the relative position command (60000 PUU), which equals 80000 PUU on the coordinate axis. The target position specified by the original command is omitted.
3. Incremental command (INC): when INC command is executed, the target position is the previous target position value plus the current position command value. In the following example, an INC command with the value of 60000 PUU is inserted in the previous PR path. The target position is the previous target position value (30000 PUU) plus the relative position command (60000 PUU), which equals 90000 PUU on the coordinate axis. The target position specified by the previous command is combined to define the new one.
4. High-speed position capturing command (CAP): when CAP command is executed, the target position is the last position acquired by the Capture function plus the position command value. Refer to Section 7.2.2 for more on the high-speed position capturing function. In the following example, a high-speed capturing command with the value of 60000 PUU is inserted in the previous PR path. The target position is the captured position value (10000 PUU) plus the relative command (60000 PUU), which equals 70000 PUU on the coordinate axis. The target position specified by the original command is omitted.



7

Figure 7.1.3.3.3 Four types of Position command

Table 7.1.3.3.1 Bit functions of PR position control

PR parameters	D	C	B	A	U	Z	Y	X
Command type	-	-	DLY	SPD	DEC	ACC	OPT	2 or 3
Data Content	Target position [PUU]							

Note:

1. Y: OPT: option

BIT	3	2	1	0	Description
Command type	CMD		OVLP	INS	-
Data Content	0	0	-	-	ABS (absolute positioning)
	0	1			REL (relative positioning)
	1	0			INC (incremental positioning)
	1	1			CAP (high-speed position capturing)

INS: interrupt command that interrupts the previous motion command.

OVLP: allow overlapping of the next command

CMD: Position command selection

- Z, U: ACC / DEC: acceleration / deceleration time set by P5.020 - P5.035.
- A: SPD: delay time, set by P5.060 - P5.075.
- B: DLY: delay time, set by P5.040 - P5.055.

### 7.1.3.4 Jump command

The PR mode includes a Jump command. It can call any PR paths or form PR paths into a loop, as shown in Figure 7.1.3.4.1. You can specify the PR path number to jump to in the PR mode screen in ASDA-Soft (see Figure 7.1.3.4.2).

7

- INS is an interrupt command that interrupts the previous motion command. Refer to Section 7.1.6 for more details.
- DLY is the delay time that is determined by the shared PR parameters. Once a Jump command is issued, the servo drive starts counting the delay time.
- Available target PR numbers are PR#00 - PR#99.

Table 7.1.3.4.1 shows the bit functions when a Jump command is in operation.

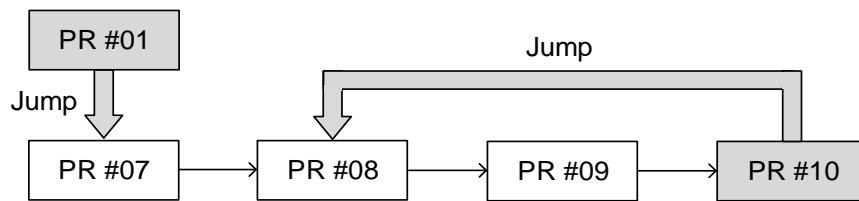

Figure 7.1.3.4.1 Jump command in PR mode

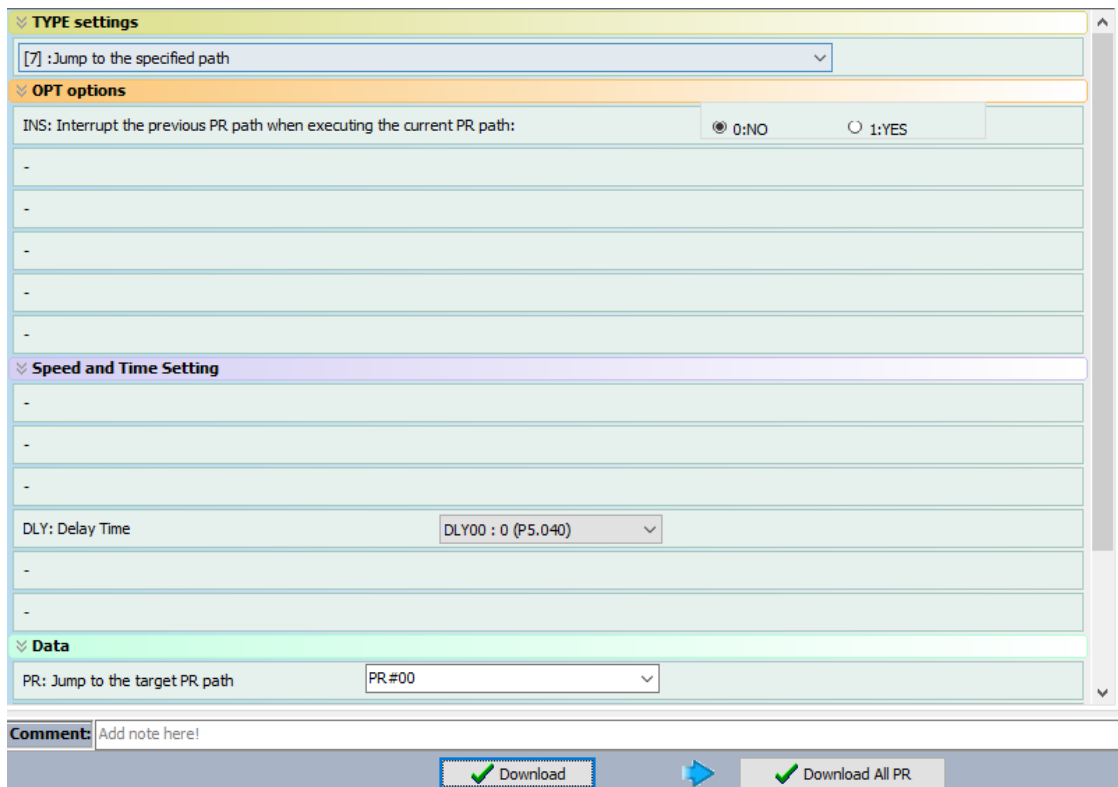

Figure 7.1.3.4.2 PR mode Jump command screen in ASDA-Soft

Table 7.1.3.4.1 Bit function of PR Jump command

PR parameters	D	C	B	A	U	Z	Y	X
Command type	-	-	DLY	-	-	-	OPT	7
Data Content	Jump to target PR path (0 - 99)							

Note:

1. Y: OPT: option

BIT	3	2	1	0
Command type	-	-	-	INS

INS: interrupt command that interrupts the previous motion command.

2. B: DLY: delay time, set by P5.040 - P5.055.

7

7

7.1.3.5 Write command

- The PR mode includes a Write command. It can write constants, parameters, data arrays, and monitoring variables to the specified parameters or to data arrays. You can write a parameter to a specified path in the PR mode screen in ASDA-Soft (see Figure 7.1.3.5.1).
- INS is an interrupt command that interrupts the previous motion command. Refer to Section 7.1.6 for more details.
- AUTO command automatically loads and executes the next PR once the current PR completes. ROM command writes parameters to both RAM and EEPROM at the same time. Writing to non-volatile memory function is also available; however, frequent usage shortens the life of the EEPROM.
- DLY is the delay time that is determined by the shared PR parameters. Once a Jump command is issued, the servo drive starts counting the delay time.

Table 7.1.3.5.1 shows the bit function when a Write command is in operation.

Writing Target	Data source
Parameter	Constant
Data array	Parameter
-	Data array
-	Monitoring variables

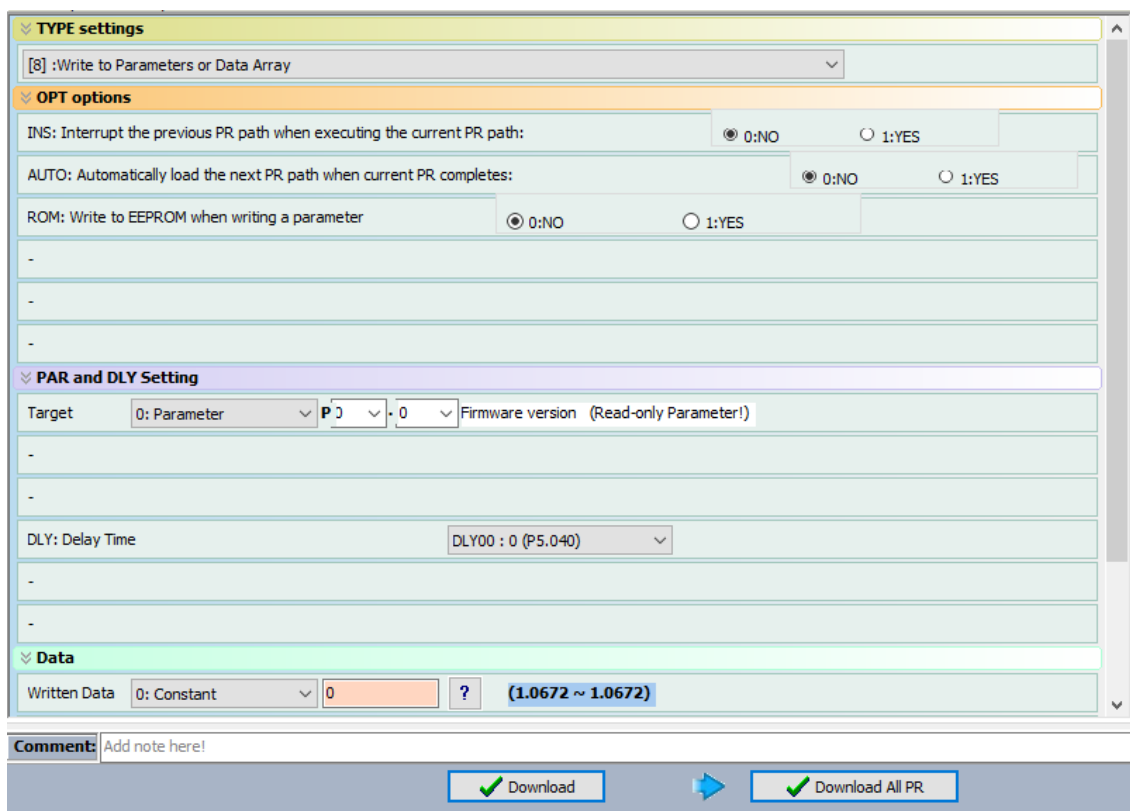

Figure 7.1.3.5.1 PR mode Write command screen in ASDA-Soft

Table 7.1.3.5.1 Bit function of PR Write command

PR parameters	D	C	B	A	U	Z	Y	X
Command type	0	SOUR_DEST	DLY	DESTINATION			OPT	8
Data Content	SOURCE							

Note:

1. Y: OPT: option

BIT	3	2	1	0
Command type	-	ROM	AUTO	INS

INS: interrupt command that interrupts the previous motion command.

AUTO: once the current PR is completed, automatically load the next command.

ROM: write data to RAM and EEPROM at the same time. This function can only write parameters.

2. B: DLY: delay time, set by P5.040 - P5.055.

3. C: SOUR\_DEST: data source and data format to be written.

BIT	3	2	1	0	Description	
Command type	SOUR		-	DEST	Data source	Writing target
Data Content	0	0	0	0	Constant	Parameter
	0	1		0	Parameter	Parameter
	1	0		0	Data array	Parameter
	1	1		0	Monitoring variable	Parameter
	0	0		1	Constant	Data array
	0	1		1	Parameter	Data array
	1	0		1	Data array	Data array
	1	1		1	Monitoring variable	Data array

4. Z, U, A: DESTINATION: destination

	A	U	Z
Target: Parameter	Parameter group	Parameter Number	
Target: Data array	Data array number		

5. SOURCE: Data source setting

	D	C	B	A	U	Z	Y	X
Data source: Constant	Constant data							
Data source: Parameter	-					Parameter group	Parameter Number	
Data source: Data array	-					Data array number		
Data source: Monitoring variable	-						Monitoring variable number	



### 7.1.3.6 Rotary Axis Position command (Index)

The PR mode includes a Rotary Axis Position command, which creates a rotary axis position system. This command positions the motor within the rotary axis position system. Unlike other feedback positions in global coordinate system, the Rotary Axis Position command is able to divide the rotary axis position scale into the number of paths required by the application (see Figure 7.1.3.6.1). When using the Rotary Axis Position command for motor operation, if the motor position exceeds the range, the absolute position or position counter overflow occurs. Refer to the setting in Chapter 10. You can start the rotary axis positioning in the Rotary Axis Position Setting Wizard (Index Coordinates Setting Wizard) in the PR screen in ASDA-Soft (see Figure 7.1.3.6.2). As shown in the example, the start PR path is set to 1, the path number is set to 8, and the total moving distance is 80000 PUU. When you click **OK**, the software automatically writes position command 0 PUU to PR#01, 10000 PUU to PR#02, 20000 PUU to PR#03, and so on up to PR#08. When the rotary axis position reaches 80000 PUU, it automatically returns to 0 PUU. In addition, you can modify the rotary axis position in each PR path as needed, as shown in Figure 7.1.3.6.3.

- INS is an interrupt command that interrupts the previous motion command (see Section 7.1.6.).
- OVLP is an overlap command that allows the next PR command to overlap the command that is currently being executed when decelerating. If you use this function, setting the delay time to 0 is suggested (refer to Section 7.1.6.).
- DIR sets the rotation direction with options of forward rotation (always runs forward), reverse rotation (always runs backward), and the shortest distance. The movement is illustrated in Figure 7.1.3.6.4.
- S\_LOW is the speed unit with options of 0.1 r/min or 0.01 r/min.
- AUTO is a command that automatically loads and executes the next PR path when the current PR completes.
- ACC / DEC is the acceleration / deceleration time determined by the shared PR parameters.
- SPD is the target speed specified by the shared PR parameters.
- DLY is the delay time that is determined by the command from controller; meaning that when motor reaches the target position, the servo drive starts counting the delay time.
- Position command is the target position of each rotary axis traveling segment. Note that the setting range must be smaller than the rotary axis position scale (P2.052).

Table 7.1.3.6.1 shows the bit functions when a Rotary Axis Position command is in operation. If you use the rotary axis position function, execute homing first in order to create the position system so that the origin of the motor's feedback position and that of the motor's rotary axis position can be identical. If you do not execute homing, AL237 occurs.

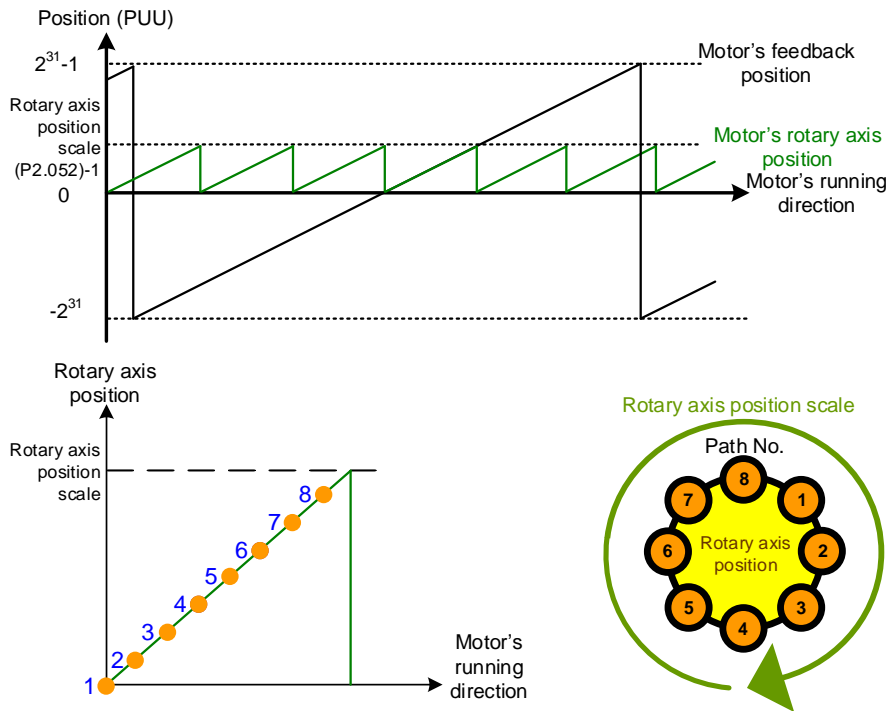

Figure 7.1.3.6.1 Rotary axis position in PR mode

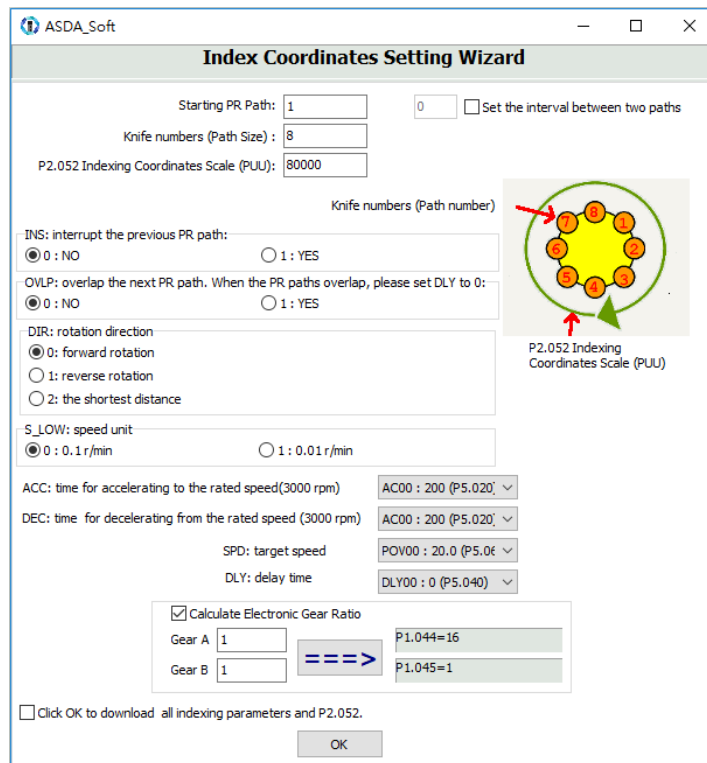

Figure 7.1.3.6.2 Rotary Axis Position Setting Wizard (Index Coordinates Setting Wizard) in PR mode

7

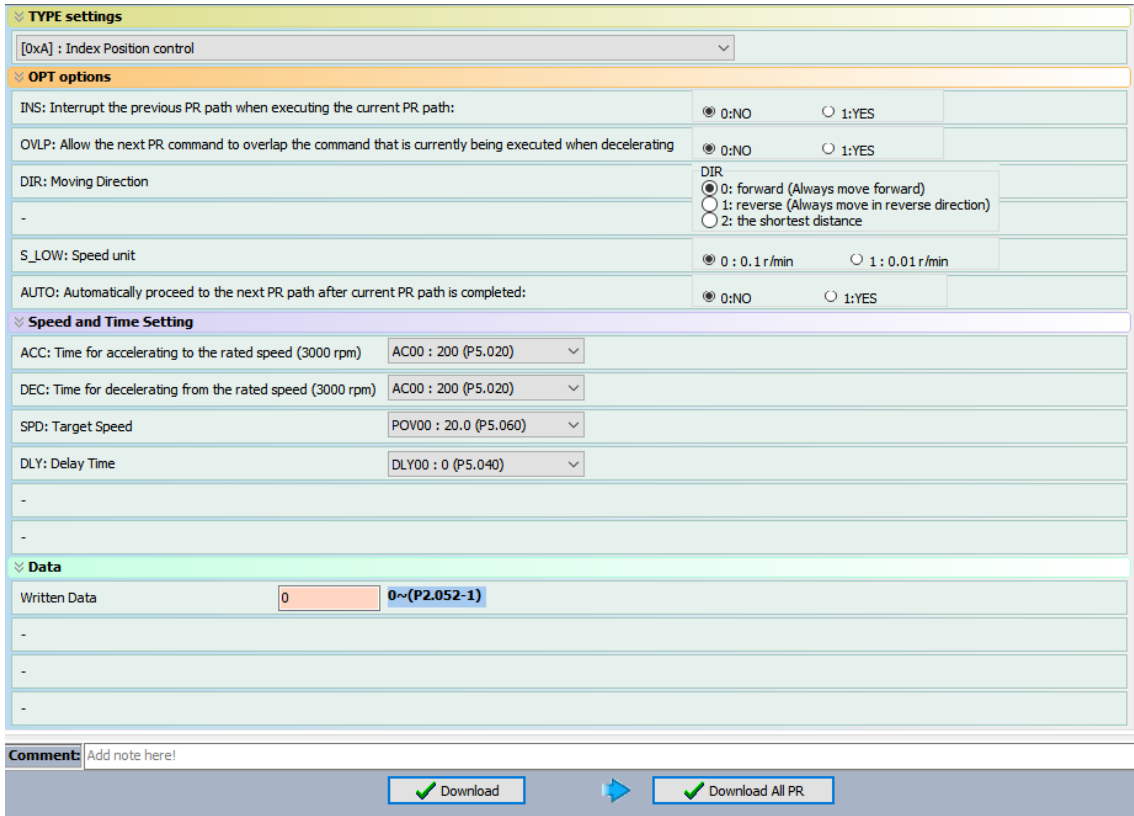

Figure 7.1.3.6.3 PR mode Rotary Axis Position control (Index Position control) screen in ASDA-Soft

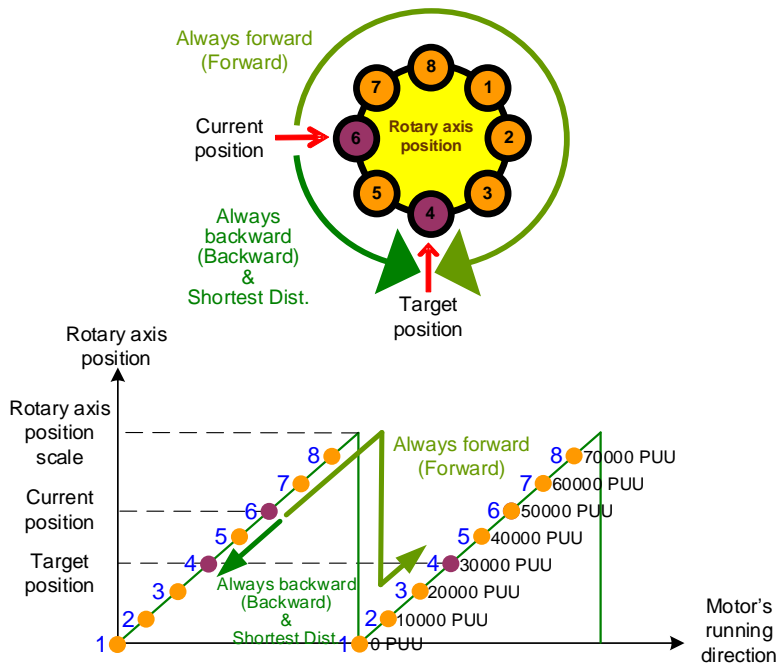

Figure 7.1.3.6.4 Motor's operation direction and rotary axis position

Table 7.1.3.6.1 Bit function of PR Rotary Axis Position command

PR parameters \ BIT	D	C	B	A	U	Z	Y	X
Command type	-	OPT2	DLY	SPD	DEC	ACC	OPT	0xA
Data Content	Rotary Axis Position command [PUU] (0 to P2.052-1)							

Note:

1. Y: OPT: option

BIT	3	2	1	0	Description
Command type	DIR		OVLP	INS	-
Data Content	0	0	-	-	Always goes forward (Forward)
	0	1			Always goes backward (Backward)
	1	0			Shortest distance
	1	1			-

INS: interrupt command that interrupts the previous motion command.

OVLP: allow overlapping of the next command

2. C: OPT2: Option 2

BIT	3	2	1	0
Command type	-	AUTO	-	S_LOW

S\_LOW: speed unit options, 0 stands for 0.1 rpm and 1 for 0.01 rpm.

AUTO: automatically load the next PR command when the current one is complete.

3. Z, U: ACC / DEC: acceleration / deceleration time set by P5.020 - P5.035.

4. A: SPD: delay time, set by P5.060 - P5.075.

5. B: DLY: delay time, set by P5.040 - P5.055.

7

7.1.3.7 Arithmetic operation (Statement)

The PR mode has arithmetic operations commands, including addition, subtraction, multiplication, division, AND, OR, MOD, and logic conditions. The available operands are user variables, parameters, data arrays, monitoring variables, and constants. Among them, the user variable is the register only for arithmetic operations. There are 64 sets of user variables, with a data size of 32 bits. The data size of a constant is also 32-bits. After all arithmetic operation commands are executed, you can set a jump condition in the path so that execution jumps to different PR path and then continues or stops once the operation is done. You can also use it as a loop function. The arithmetic operation commands support negative integer operations but not floating point operations. Negative integer operations are calculated by “two’s complement”. Figure 7.1.3.7.1 is the Arithmetic Operations screen in ASDA-Soft. Arithmetic operations must be created in ASDA-Soft. To avoid errors, do not use the servo panel or RS-485 for arithmetic operations. Once you complete the arithmetic operation, click **Download All PR** to write all PR paths to the servo drive.

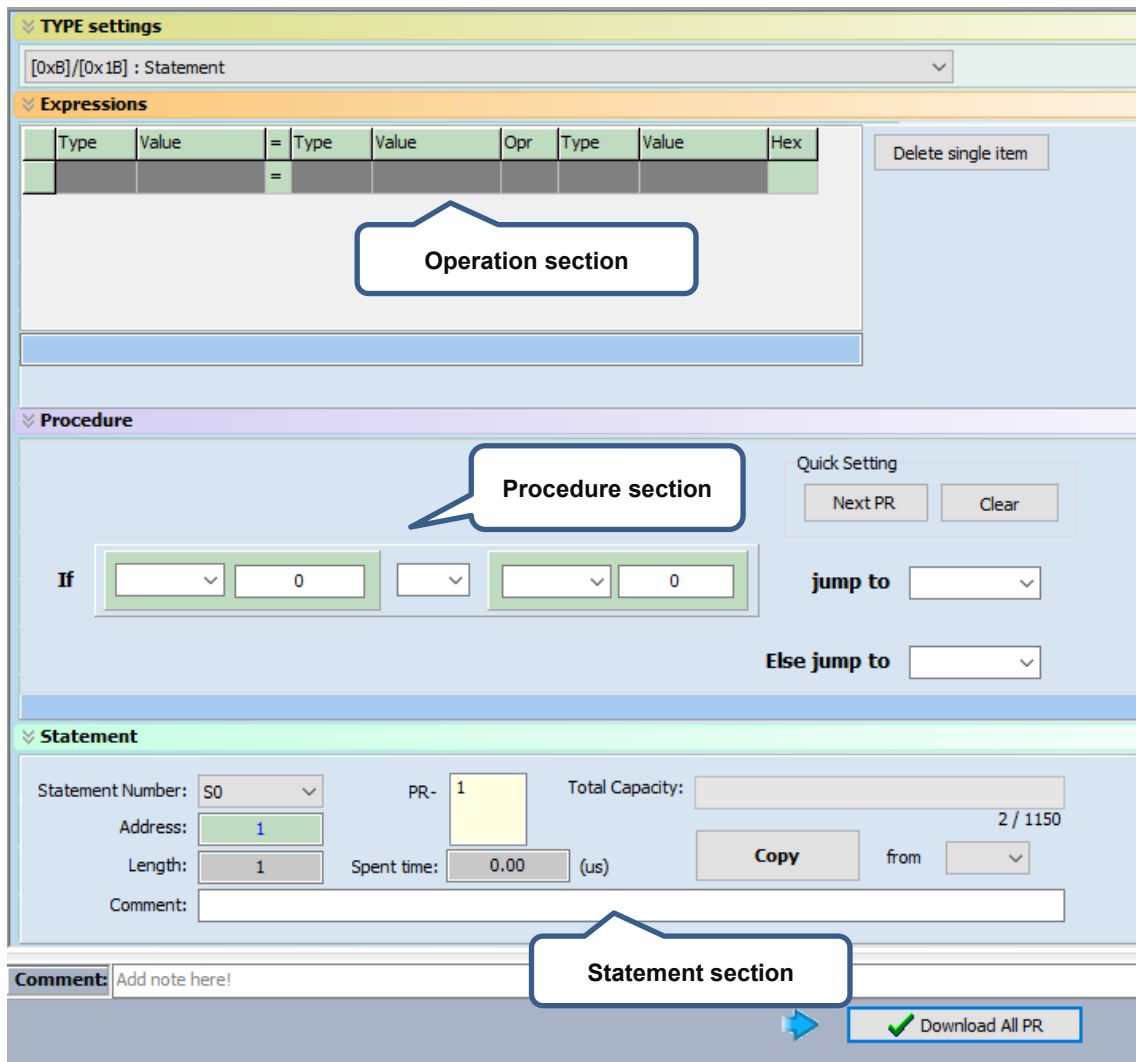

Figure 7.1.3.7.1 PR mode Arithmetic Operations screen in ASDA-Soft

1. Operation section: supports addition, subtraction, multiplication, division, AND, OR, and MOD operation as well as logical operations for multiple data. Table 7.1.3.7.1 shows the supported operators and calculation data with data format in DEC and HEX.

Table 7.1.3.7.1 Description of each field in the Operation section

Data to be written	=	Calculation data	Operator	Calculation data	
User variable (User[0-63])		User variable (User[0-63])	Addition (+) Deduction (-) Multiplication (*) Division (/) Obtain remainder (%) And (&) Or ( )	User variable (User[0-63])	
		Constant (Constant)			
Parameter (PX.XXX)		Data array (Arr[0-799])		Constant (Constant)	
		Parameter (PX.XXX)			
Data array (Arr[0-799])		Monitoring variable (Mon[*])			Data array (Arr[0-799])

2. Procedure section: uses the IF statement to determine whether the user-defined condition is fulfilled. If true, jump to the next specified PR path; if false, jump to the other specified PR path. If you click **Next PR** in Quick Setting, the software automatically inputs the condition and then jumps to the next PR path. If you leave this section blank, then the PR procedure stops once the basic operation is done. Table 7.1.3.7.2 shows the supported data formats and operators.

Table 7.1.3.7.2 Field description for the Procedure setting section

Data format	Operator	Data format
User variable (User[0-63])	Greater than (>) Greater than or equal to (>=) Less than (<) Less than or equal to (<=) Equal to (==) Not equal to (!=)	User variable (User[0-63])
Constant (Constant)		
Data array (Arr[0-799])		Constant (Constant)
Parameter (PX.XXX)		
Monitoring variable (Mon[*])		Data array (Arr[0-799])

7

- Statement section: this section includes statements and memory capacity. Statements save the data from the expression and procedure sections. Data in the expression and procedure sections of the same statement always remain identical and can be shared by multiple PR paths. If data in those two sections are different, then the data is saved to another statement. The time required to execute the statement is shown in the Spend time field. Total Capacity shows the servo drive's memory capacity; basic operations cannot be performed if there is no memory space available. The Statements tab is shown in Figure 7.1.3.7.2. The upper section displays all the statements and the lower section displays the operations and settings in each statement.

Pr. Mode Chart Statements User Variable

Statement information:

	Name	table	Address	Length	Time	PR#	Comment
1	S0	V	1	16	2.86	22,	
2	S1	V	17	9	1.67		
3	S2	V	26	9	1.67		
4	S3	V	35	9	1.67		

Add Copy To  Select All

Delete Select [S] to

Statements programs list :

0	S0	START					
1	User[*]	1	= Px.xxx	P4.7	&	Constant	576
2	IF	User[*]=0	True ->	PR.#5		False ->	
3	S1	START					
4	IF	P4.7<60	True ->	PR.#40		False ->	
5	S2	START					

Figure 7.1.3.7.2 Statements tab in ASDA-Soft

### 7.1.4 Overview of the PR procedure

In the PR mode, there are seven types of commands. To understand how the PR procedure works, ASDA-Soft presents the execution order and calling sequence of all PR procedures. First, symbols and contents in the PR figure are shown. This includes five parts: number, command execution type (property), command type, next procedure command, and command information. See Figure 7.1.4.1.

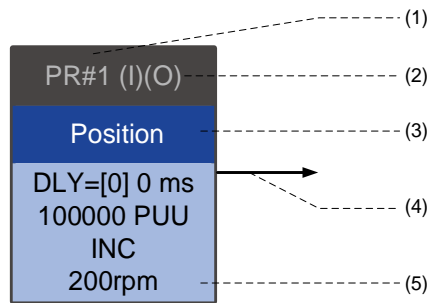

Figure 7.1.4.1 PR display

- (1) Number: the PR number, ranging from PR#0 to PR#99 (100 sets of PR paths).
- (2) Command execution type (property): (B) execute homing when power on; (O) command overlap; (R) write data to EEPROM; (I) command interrupt.
- (3) Command type: there are seven types of PR path commands: homing, speed, position, writing, jumping, rotary axis positioning, and arithmetic operations. The color displayed in this section depends on the command type.
- (4) Next procedure command: if followed by a PR command, the arrow points to the specified PR path.
- (5) Command information: displays the details of this PR path. The displayed contents and color depend on the information type.

The following sections illustrate each command type and its representation.

#### Homing methods

In the display of homing methods, PR#0 always signifies the homing procedure, which is marked as "Homing". See Figure 7.1.4.2.

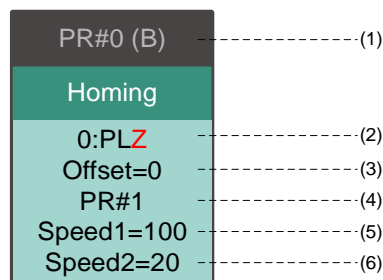

Figure 7.1.4.2 Homing methods display



7

- (1) Activation mode (Boot): to execute homing when the drive is in Servo On state after powered on, it displays (B); if homing is not required, then no information is displayed.
- (2) Method selection: homing methods and Z pulse setting are shown in the following table. Characters in red indicate the motor's position after homing; F signifies running forward; R signifies running in reverse; ORG signifies origin; CUR signifies current position; BUMP signifies the hard stop.

Homing method	Y = 0: reverse to look for Z pulse Y = 1: go forward to look for Z pulse	Y = 2: do not look for Z pulse
X = 0: homing in forward direction with PL as the homing origin	0: PLZ	0: PL
X = 1: homing in reverse direction with NL as the homing origin	1: NLZ	1: NL
X = 2: homing in forward direction with ORG (when it switches from off to on state) as the homing origin	2: F_ORGZ	2: F_ORG
X = 3: homing in reverse direction with ORG (when it switches from off to on state) as the homing origin	3: R_ORGZ	3: R_ORG
X = 4: look for the Z pulse in forward direction with it as the homing origin	4: F_Z	
X = 5: look for the Z pulse in reverse direction with it as the homing origin	5: R_Z	
X = 6: homing in forward direction with ORG (when it switches from on to off state) as the homing origin	6: F_ORGZ	6: F_ORG
X = 7: homing in reverse direction with ORG (when it switches from on to off state) as the homing origin	7: R_ORGZ	7: R_ORG
X = 8: use the current point as the origin	8: CUR	
X = 9: Torque homing in forward direction	9: F_BUMPZ	9: F_BUMP
X = A: Torque homing in reverse direction	A: R_BUMPZ	A: R_BUMP

- (3) Offset: origin offset, P6.001.
- (4) Path: next PR path to be executed after homing.
- (5) Homing at high speed: first homing speed, P5.005.
- (6) Homing at low speed: second homing speed, P5.006.

## Speed command

You can use the Speed command in any PR paths (PR#1 - PR#99). It is marked as "Speed".

See Figure 7.1.4.3.

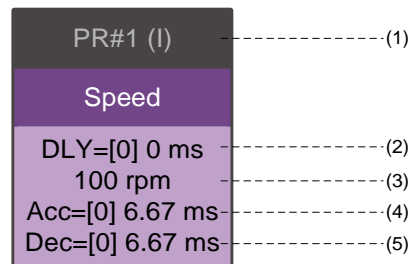

Figure 7.1.4.3 Speed command display

- (1) Command execution type (property): a Speed command can interrupt (INS) the previous PR path. If the Interrupt function is enabled, it displays (I); if not, no information is displayed.
- (2) Delay time (DLY): determined by shared PR parameters. It is defined by a command from the controller; the servo drive starts counting the delay time once the motor reaches the target speed.
- (3) Target speed: the set target speed.
- (4) Acceleration time (ACC): determined by shared PR parameters; length of time to reach the target speed from stopped.
- (5) Deceleration time (DEC): determined by shared PR parameters; length of time to decelerate from target speed to stopped.

**Position command**

You can use the Position command in any PR paths (PR#1 - PR#99). It is marked as “Position”, and includes the options to “Stop once position control completed” and “Load the next path once position control completed”. The only difference is that “Load the next path once position control completed” shows an arrow pointing to the next PR. See Figure 7.1.4.4.

7

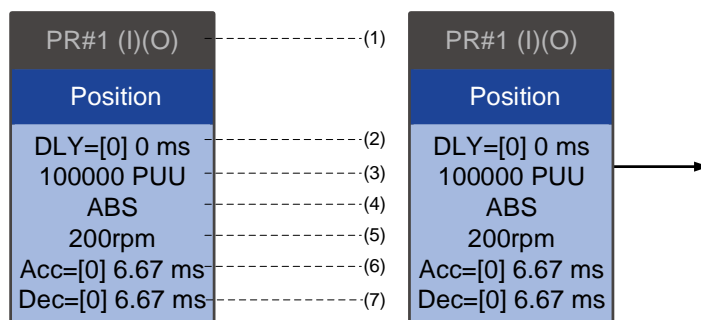

Figure 7.1.4.4 Position command display

- (1) Command execution type (property): a Position command can interrupt (INS) the previous PR path. If the Interrupt function is enabled, it displays (I); if not, no information is displayed. The Position command can overlap (OVLP) the next PR path. Set the delay time to 0 when you use the Overlap function. If the Overlap function is used, it displays (O); if not, no information is displayed.
- (2) Delay time (DLY): determined by shared PR parameters. It is defined by a command from the controller. The servo drive starts counting the delay time once the motor reaches the target position.
- (3) Target position: the set target position.
- (4) Position command type: “ABS” means absolute positioning; “REL” means relative positioning; “INC” means incremental positioning; “CAP” means high-speed position capturing.
- (5) Target speed: determined by shared PR parameters.
- (6) Acceleration time (ACC): determined by shared PR parameters; length of time to reach the target speed from stopped.
- (7) Deceleration time (DEC): determined by shared PR parameters; length of time to decelerate from target speed to stopped.

**Jump command**

You can use the Jump command in any PR paths (PR#1 - PR#99). It is marked as “Jump” and followed by an arrow pointing to the next PR path. See Figure 7.1.4.5.

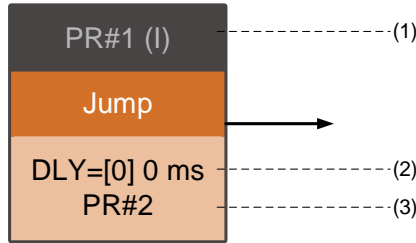

Figure 7.1.4.5 Jump command display

- (1) Command execution type (property): a Jump command can interrupt (INS) the previous PR path. If the Interrupt function is enabled, it displays (I); if not, no information is displayed.
- (2) Delay time (DLY): determined by shared PR parameters.
- (3) Target PR number: the set target PR number.

**Write command**

You can use the Write command in any PR paths (PR#1 - PR#99). It is marked as “Write”. See Figure 7.1.4.6.

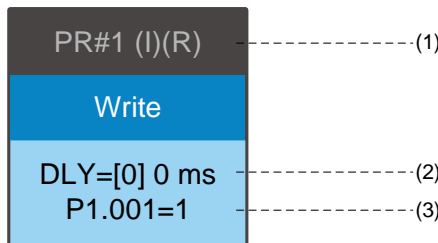

Figure 7.1.4.6 Write command display

- (1) Command execution type (property): a Write command can interrupt (INS) the previous PR path. If the Interrupt function is enabled, it displays (I); if not, no information is displayed. You can determine whether to write the data to EEPROM. If writing data to EEPROM is required, it displays (R); if not, no information is displayed.
- (2) Delay time (DLY): determined by shared PR parameters.
- (3) Writing target and data source: the corresponding target and data sources are shown in the following table. Note that constants can be written in DEC or HEX format.

Writing target	Data source
Parameter(PX.XXX)	Constant
Data array (Arr[#])	Parameter (PX.XXX)
-	Data array (Arr[#])
-	Monitoring variable (Mon[#])

**Rotary Axis Position command (Index Position)**

You can use the Rotary Axis Position command in any PR paths (PR#1 - PR#99). The number of PR paths is determined by the number of Rotary Axis Position commands. It is marked as "Index Position". See Figure 7.1.4.7.

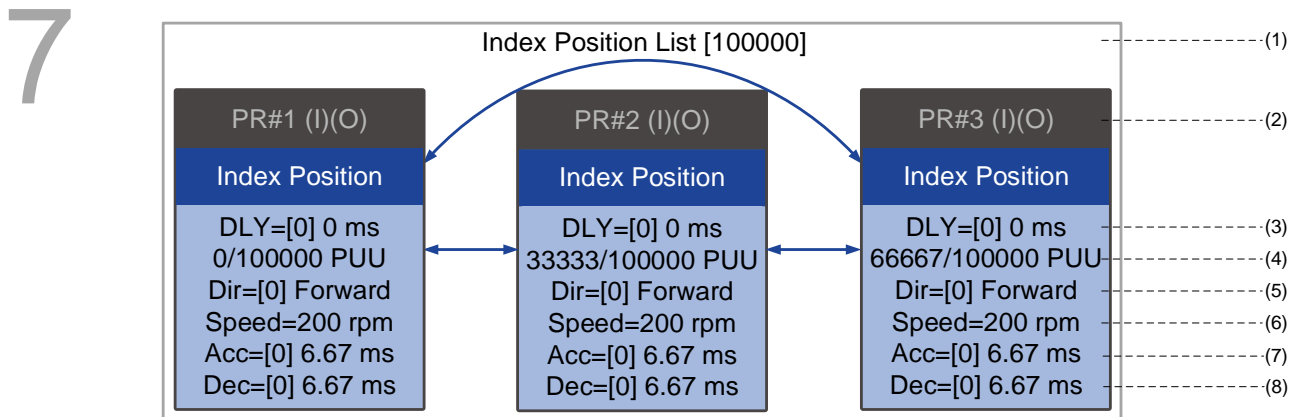

Figure 7.1.4.7 Rotary Axis Position command (Index Position) display

- (1) Rotary Axis Position command section: a set of Rotary Axis Position commands. It shows the total moving distance at the top using double arrows to show that the motor can run reciprocally between each target position in each PR path.
- (2) Command execution type (property): a Rotary Axis Position command can interrupt (INS) the previous PR path. If the Interrupt function is enabled, it displays (I); if not, no information is displayed. The Rotary Axis Position command can overlap (OVLP) the next PR path. Set the delay time to 0 when you use the Overlap function. If the Overlap function is used, it displays (O); if not, no information is displayed.
- (3) Delay time (DLY): determined by shared PR parameters. It is defined by a command from the controller. The servo drive starts counting the delay time once the motor reaches the target position.
- (4) Position command: the numerator is the position of this PR path; the denominator is the total moving distance of this Rotary Axis Position command, which is set by P2.052.
- (5) Rotation direction (Dir): available options are "Rotation forward (Forward)", "Rotation in reverse (Reverse)", and "Rotation with the shortest distance (Shortest)".
- (6) Target speed: determined by shared PR parameters.
- (7) Acceleration time (ACC): determined by shared PR parameters; length of time to reach the target speed from stopped.
- (8) Deceleration time (DEC): determined by shared PR parameters; length of time to decelerate from target speed to stopped.

### Arithmetic operation (Statement)

You can use arithmetic operations and statements in any PR paths (PR#1 - PR#99). It is marked as "Statement". When the condition is fulfilled, an arrow pointing to the next PR path appears with a solid line; if the condition is unfulfilled, an arrow pointing to the next PR appears with a dotted line; or you can choose to execute the next PR path and stop it once the execution is complete. See Figure 7.1.4.8.

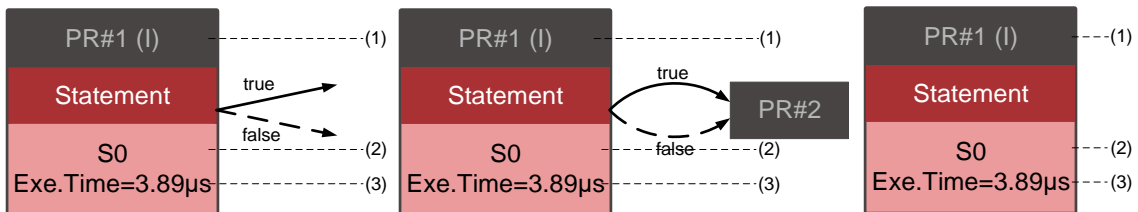

Figure 7.1.4.8 Arithmetic operation display

- (1) Command execution type (property): an arithmetic operation command can interrupt (INS) the previous PR path. If the Interrupt function is enabled, it displays (I); if not, no information is displayed.
- (2) Statement number: displays the statement number used in the PR path.
- (3) Execution time (Exe. Time): the time required to execute the arithmetic operation.

7

**7.1.5 Trigger methods for the PR command**

There are six types of PR trigger methods. They are DI-triggered, Event-triggered, P5.007-triggered, Capture-triggered (high-speed position capturing), Compare-triggered (high-speed position comparing), and E-Cam-triggered. You can choose the most suitable trigger method according to the applications and requirements.

**Digital input (DI) triggering**

You can choose the PR path to be executed by using the internal registers (Position command Bit 0 - Bit 6) and use a command to trigger the selected PR path. Before using DI-triggering commands, you must define the 8 sets of DI functions, which are [0x11]POS0, [0x12]POS1, [0x13]POS2, [0x1A]POS3, [0x1B]POS4, [0x1C]POS5, [0x1E]POS6, and [0x08]CTRG (refer to Table 8.1). You can also set these functions in the I/O screen in ASDA-Soft, as shown in Figure 7.1.5.1.

Digital Input (DI) : ASDA-A3 Servo:Pr Mode	Status	Enable
DI1:[0x01]Servo On	Off	<input type="checkbox"/> On/Off
DI2:[0x08]Command triggered	Off	<input type="checkbox"/> On/Off
DI3:[0x11]Register Position command selection 1 - 99 Bit0	Off	<input type="checkbox"/> On/Off
DI4:[0x12]Register Position command selection 1 - 99 Bit1	Off	<input type="checkbox"/> On/Off
DI5:[0x13]Register Position command selection 1 - 99 Bit2	Off	<input type="checkbox"/> On/Off
DI6:[0x1A]Register Position command selection 1 - 99 Bit3	Off	<input type="checkbox"/> On/Off
DI7:[0x1B]Register Position command selection 1 - 99 Bit4	Off	<input type="checkbox"/> On/Off
DI8:[0x1C]Register Position command selection 1 - 99 Bit5	Off	<input type="checkbox"/> On/Off
DI9:[0x1E]Register Position command selection 1 - 99 Bit6	Off	<input type="checkbox"/> On/Off
DI10:[0x00]Disabled	Off	<input type="checkbox"/> On/Off
DI11:[0x00]Disabled	Off	<input type="checkbox"/> On/Off
DI12:[0x00]Disabled	Off	<input type="checkbox"/> On/Off
DI13:[0x00]Disabled	Off	<input type="checkbox"/> On/Off

Figure 7.1.5.1 I/O screen in ASDA-Soft

Select the PR number to be executed based on the on / off status of DI.POS0 - 6 and use DI.CTRG to trigger the specified PR path. See Figure 7.1.5.1 for an example.

Table 7.1.5.1 Use DI to select the PR path to be triggered

Position command	POS6	POS5	POS4	POS3	POS2	POS1	POS0	CTRG	Corresponding Parameter
Homing	0	0	0	0	0	0	0	↑	P6.000
									P6.001
PR#1	0	0	0	0	0	0	1	↑	P6.002
									P6.003
...									...
PR#50	0	1	1	0	0	1	0	↑	P6.098
									P6.099
PR#51	0	1	1	0	0	1	1	↑	P7.000
									P7.001
...									...
PR#99	1	1	0	0	0	1	1	↑	P7.098
									P7.099

7

In addition, there are two sets of DI for special functions: [0x27] Enable homing and [0x46] Motor stops. If the former is triggered, the servo drive executes homing based on the homing setting. If the latter is triggered, the servo drive stops the motor. You can use the I/O screen in ASDA-Soft to set these functions, as shown in Figure 7.1.5.2.

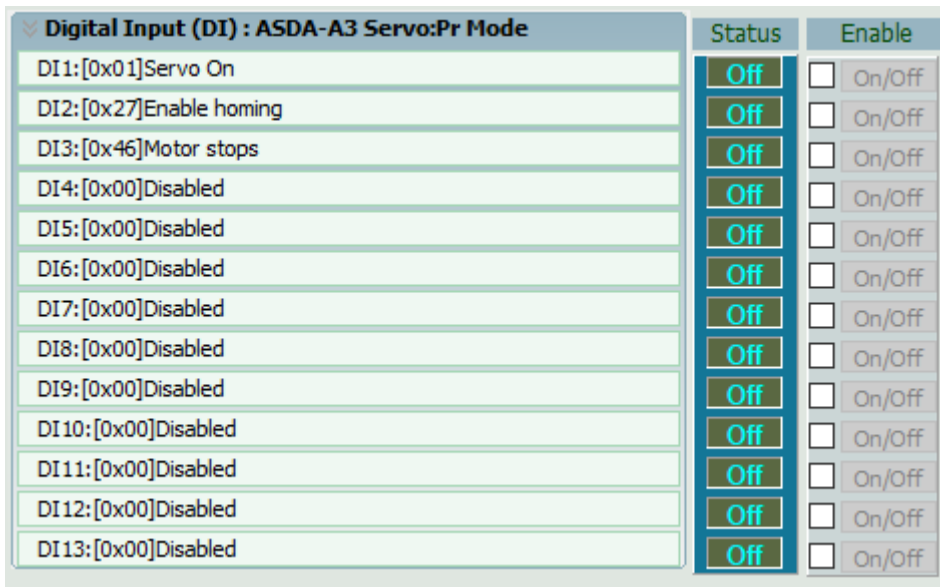

Figure 7.1.5.2 I/O screen in ASDA-Soft



7

**Event triggering**

You can use Event-triggered commands 1 - 4 to execute the specified PR path. You can select two types of Event triggering: rising-edge trigger and falling-edge trigger. The range of PR path numbers that you can specify is from 51 - 63 (see the example in Figure 7.1.5.3). Before using the Event-trigger for PR command, you must define the DI functions, which are [0x39] Event trigger command 1, [0x3A] Event trigger command 2, [0x3B] Event trigger command 3, and [0x3C] Event trigger command 4 (see Table 8.1). You can use the I/O screen in ASDA-Soft to set these functions. as shown in Figure 7.1.5.4.

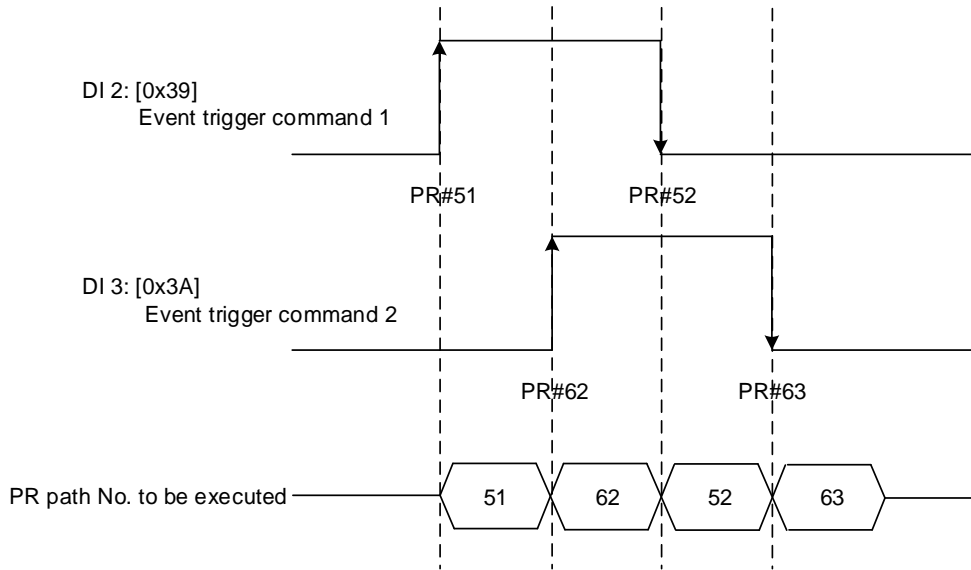

Figure 7.1.5.3 Example of Event triggering timing diagram

Digital Input (DI) : ASDA-A3 Servo:Pr Mode		Status	Enable
DI1:[0x01]Servo On		Off	<input type="checkbox"/> On/Off
DI2:[0x39]Event trigger command 1		Off	<input type="checkbox"/> On/Off
DI3:[0x3A]Event trigger command 2		Off	<input type="checkbox"/> On/Off
DI4:[0x3B]Event trigger command 3		Off	<input type="checkbox"/> On/Off
DI5:[0x3C]Event trigger command 4		Off	<input type="checkbox"/> On/Off
DI6:[0x00]Disabled		Off	<input type="checkbox"/> On/Off
DI7:[0x00]Disabled		Off	<input type="checkbox"/> On/Off
DI8:[0x00]Disabled		Off	<input type="checkbox"/> On/Off
DI9:[0x00]Disabled		Off	<input type="checkbox"/> On/Off
DI10:[0x00]Disabled		Off	<input type="checkbox"/> On/Off
DI11:[0x00]Disabled		Off	<input type="checkbox"/> On/Off
DI12:[0x00]Disabled		Off	<input type="checkbox"/> On/Off
DI13:[0x00]Disabled		Off	<input type="checkbox"/> On/Off

Figure 7.1.5.4 I/O screen in ASDA-Soft

You can set the rising-edge trigger of the PR path with P5.098 and set the falling-edge trigger with P5.099. Refer to Chapter 8 for more details. Users can use ASDA-Soft to set the event trigger of PR. See Figure 7.1.5.5.

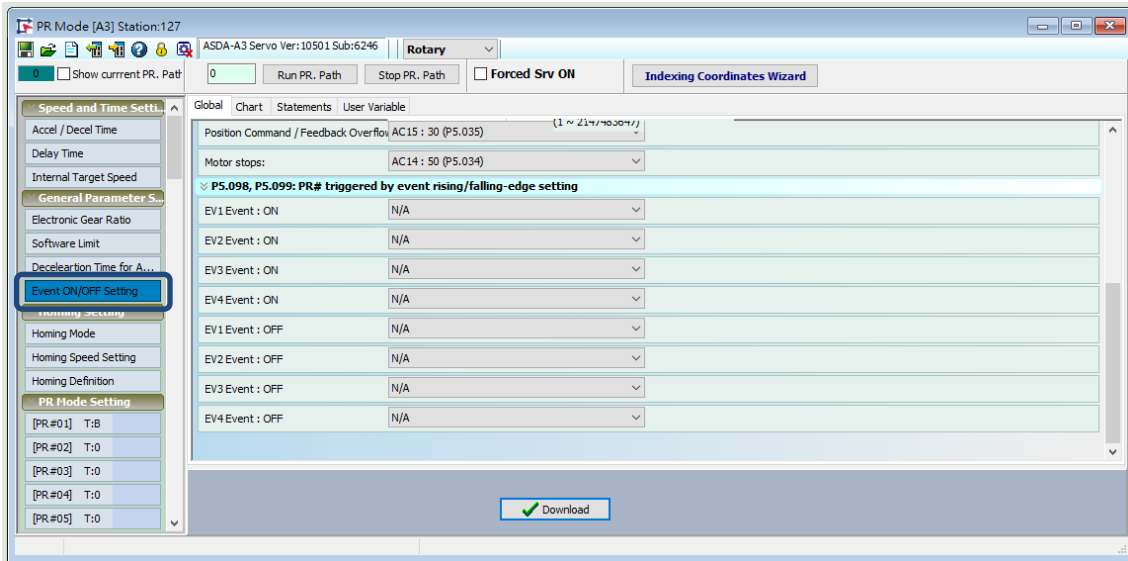

Figure 7.1.5.5 Event ON/OFF Setting screen in ASDA-Soft

**PR command trigger register (P5.007)**

You can write the PR number to be executed in P5.007 to make the servo drive execute the specified PR path. If you write 0 to the PR Command Trigger register, the servo drive executes homing. If you write 1 - 99 to the PR Command Trigger register, the servo drive executes the specified PR path. If you write 1000 to the PR Command Trigger register, the servo drive stops executing PR commands. You can find more information in the description of P5.007 in Chapter 8.

**Special trigger method**

You can use High-speed position capture (Capture), High-speed position compare (Compare), and the E-Cam function to trigger the specified PR path. When the capturing completes, you can set whether to trigger PR#50 with P5.039.X Bit 3, or whether to trigger PR#45 once the last data is compared with P5.059.U Bit 0. If the E-Cam disengagement setting is 2, 4, or 6, use P5.088.BA to write the PR path number. Refer to Section 7.2 and 7.3 for Capture, Compare, and E-Cam functions.

Trigger method	Setting bit	Trigger PR path
High-speed position capture (Capture)	P5.039.X Bit 3	PR#50
High-speed position compare (Compare)	P5.059.U Bit 0	PR#45
E-Cam	P5.088.BA	User-defined

7

7

7.1.6 PR procedure execution flow

The ASDA-A3 updates the command status every 1 ms. Figure 7.1.6.1 illustrates the PR procedure execution flow and how the servo drive deals with PR commands. Once a PR procedure is triggered, it goes through three units, which are PR queue, PR executor, and motion command generator.

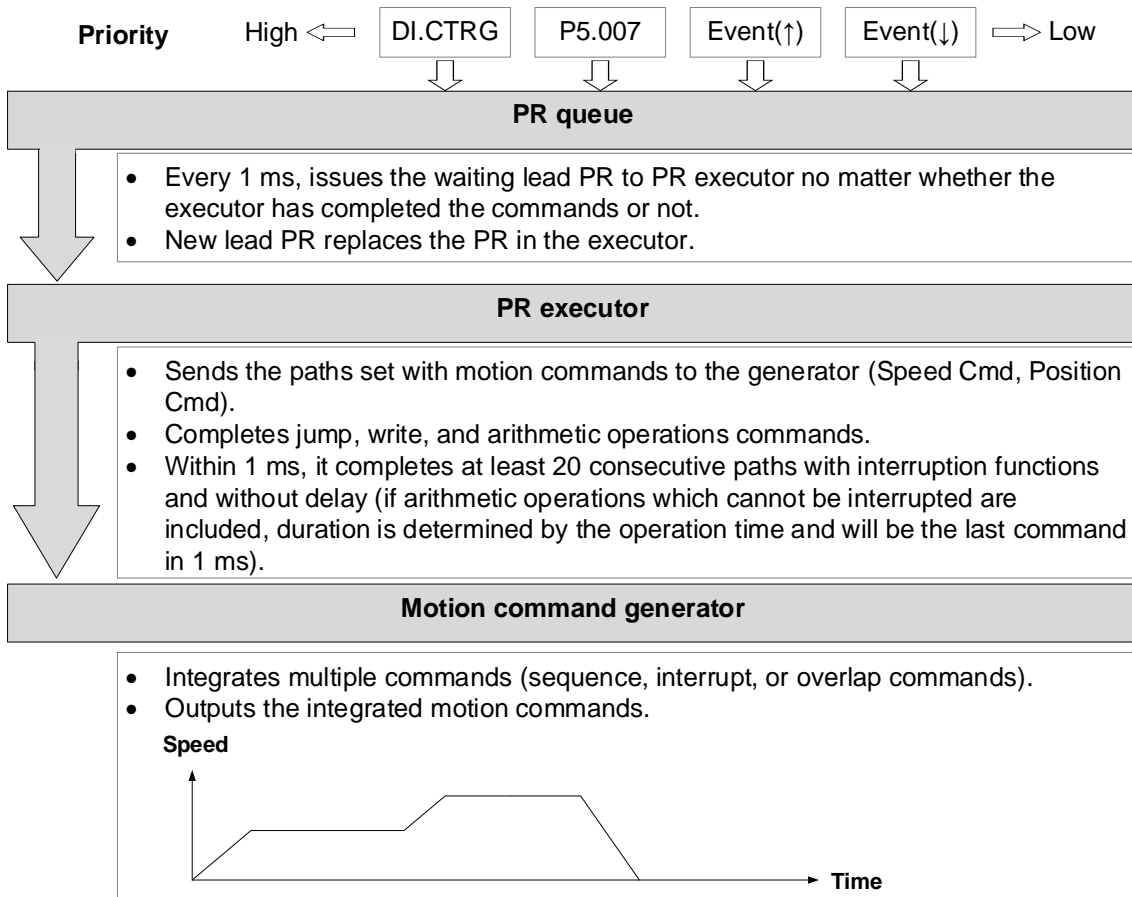

Figure 7.1.6.1 PR execution flow in the ASDA-A3

■ Trigger mechanism

The trigger mechanism is as mentioned in Section 7.1.5. There are three trigger methods. A PR procedure is executed as long as a trigger signal is output. When two different trigger methods are used for one PR procedure within the same ms, the priority is as follows: DI trigger (DI.CTRG) > PR command trigger register (P5.007) > Rising-edge event trigger (Event ↑) > Falling-edge event trigger (Event ↓). Within this ms, commands with higher priority are executed first and then the lower priority commands are arranged in the next ms. If three trigger commands are generated in the same ms, the third is not added to the PR queue.

### ■ PR queue

The triggered PR path is the lead PR. The PR group it leads goes into the PR queue to wait for prioritization. In each ms, the servo drive sends the lead PR and the PR group it leads to the PR executor with a first-in first-out method no matter whether a PR path is being executed. Therefore, as long as a PR path is triggered, the PR queue collects it and sends it to the executor.

### ■ PR Executor

Once the PR executor receives the lead PR and its PR group, the PR group that is being executed will be replaced immediately. If a PR group includes motion commands, such as Speed commands and Position commands, then the PR executor sends them to the motion command generator. PR paths with Write or Jump commands are complete at the moment when the PR executor reads the command, and thus they do not enter the generator. The arithmetic operations commands are executed when entering the PR executor; however, the execution time varies with the computing duration and the next command cannot interrupt during computing. The PR executor can consecutively complete at least 20 PR paths with interrupt commands (INS) (without delay times) within 1 ms. If there is a PR path that has not completed within 1 ms, and a new PR group is sent to the executor by the queue, the new PR group then replaces the previous PR group. In other words, instead of executing the PR group that hasn't been completed, the executor starts executing the new PR group. However, if a new PR group hasn't been sent to the executor yet after 1 ms, the executor continues to execute the unfinished PR path.

### ■ Motion command generator

Motion commands include the Speed and Position commands. The PR executor sends these types of commands to the motion command generator. This generator has a buffer for temporarily storing the next motion command and all motion commands are integrated here. Motion commands can be executed as long as they enter the generator. If another motion command (with interrupt setting) also enters the generator, it is integrated with the current command in the generator and the integration is based on the motion command settings. The settings include whether multiple motion commands are sequence commands and whether they are set with the Overlap or Interrupt function. All integration varies with each PR path setting.

### Sequence command

The configurable motion commands for PR paths are Position and Speed commands. A sequence command is a motion command without an Overlap or Interrupt function. The following command starts to be executed only after the delay set in the previous command. Regarding Position commands, the delay time starts to count after the target position is reached. For Speed command, the delay time counting starts after the target speed is reached.

7

■ Position command followed by a Position command

When the PR executor receives two consecutive Position commands, if they do not have Interrupt or Overlap functions, the PR executor issues the first Position command to the motion command generator, and the generator starts the first part of position control. After the first Position command completes, if no delay time is set, the PR executor issues the second Position command for the generator to start the second part of position control (see Figure 7.1.6.2 (a)).

If the first Position command includes a delay, the PR executor starts counting the delay time right after the motor reaches the target position. Then it issues the second Position command for the generator to start the second part of position control as shown in Figure 7.1.6.2 (b).

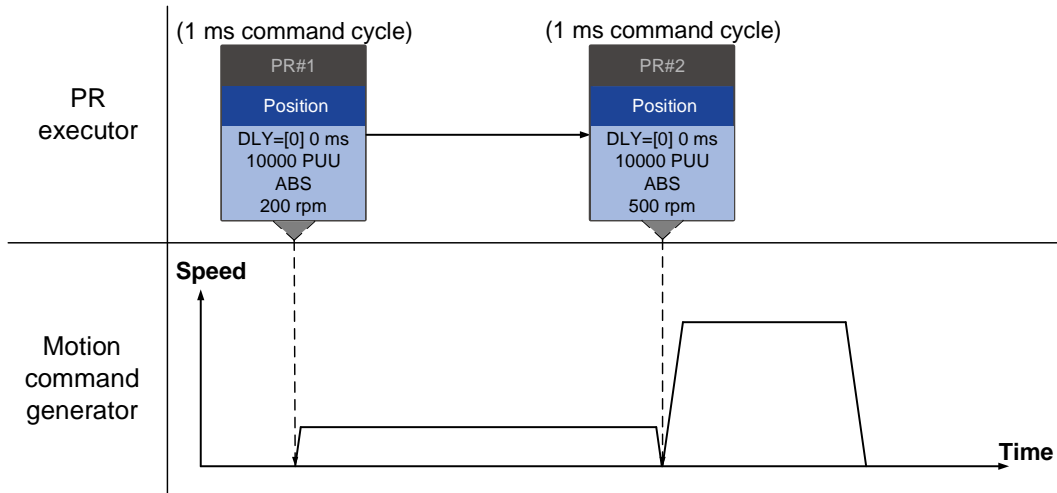

(a) Position command without delay

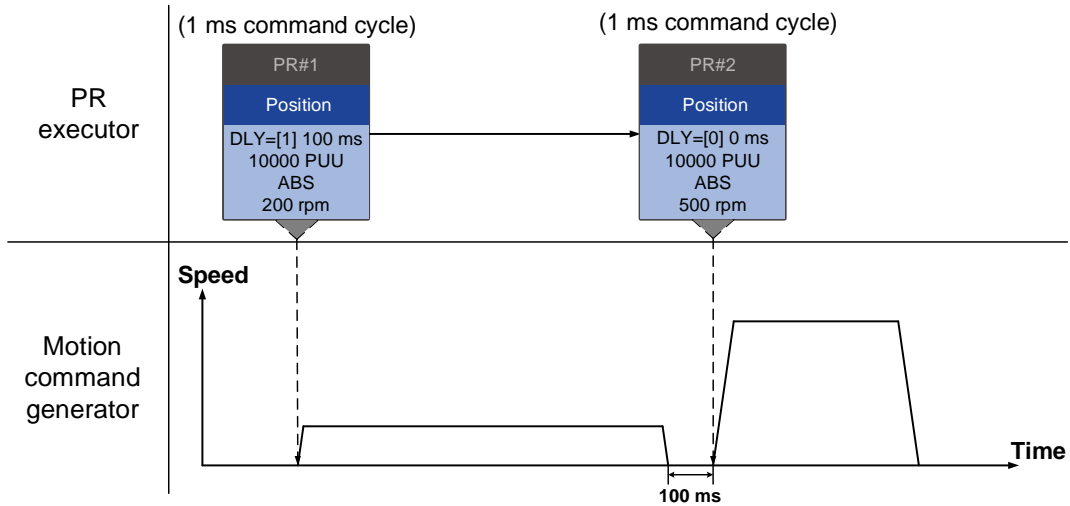

(b) Position command with delay

Figure 7.1.6.2 Position sequence command

■ Speed command followed by a Speed command

When the PR executor receives two consecutive Speed commands, if they do not have Interrupt or Overlap functions, the PR executor issues the first Speed command to the motion command generator, and the generator starts the first part of speed control. After the first Speed command completes, if no delay time is set, the PR executor issues the second Speed command for the generator to start the second part of speed control (see Figure 7.1.6.3 (a)). If the first Speed command includes a delay, the PR executor starts counting the delay time right after the motor reaches the target speed. Then it issues the second Speed command for the generator to start the second part of speed control as shown in Figure 7.1.6.3 (b).

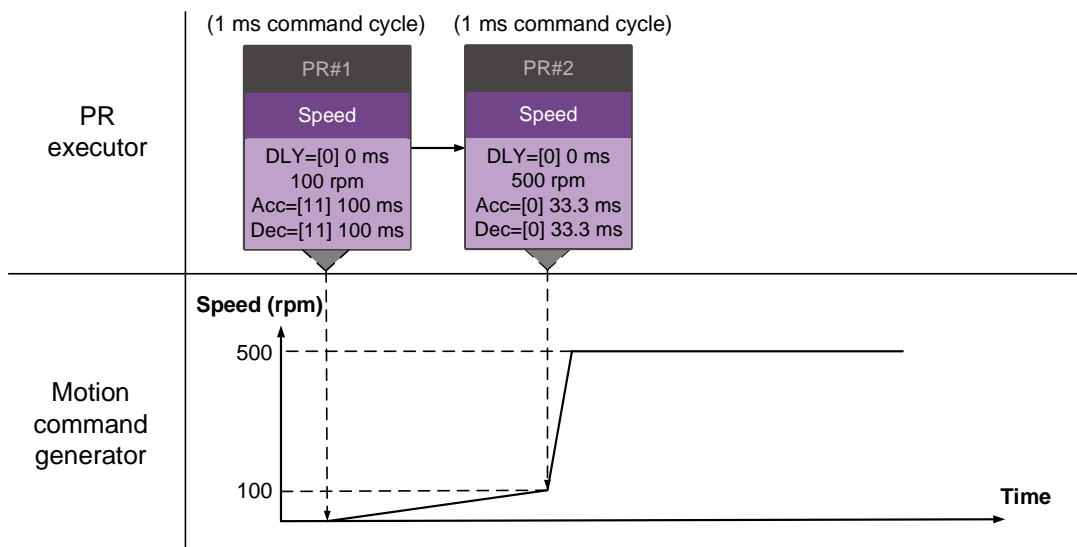

(a) Speed command without delay

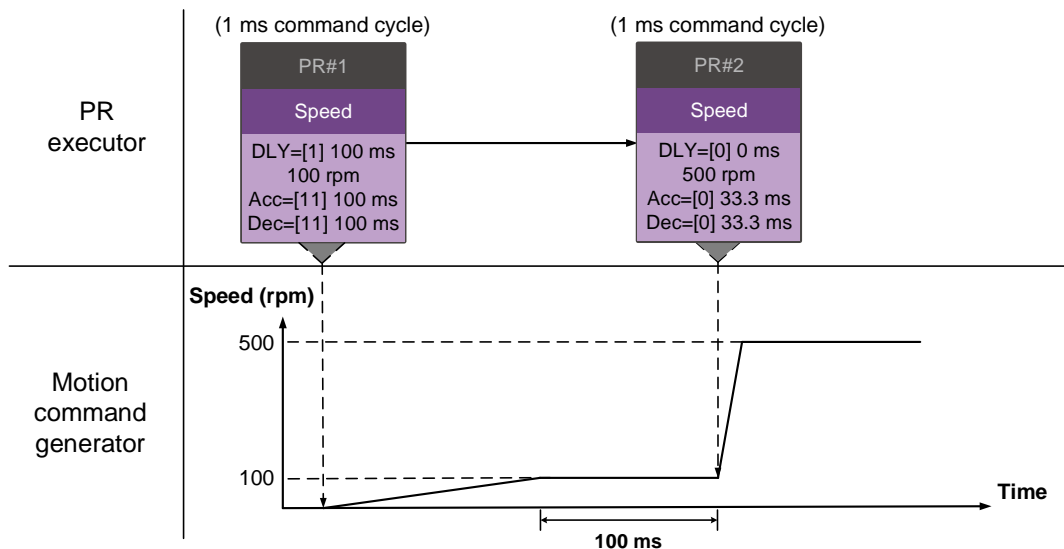

(b) Speed command with delay

Figure 7.1.6.3 Speed sequence command

7

■ Multiple commands

The PR queue updates commands every 1 ms. For a motion command, the PR queue sends the next command to the generator only after the previous command completes. Jump or Write commands are executed in the PR queue immediately. As shown in Figure 7.1.6.4, in the first ms, the PR queue receives a Position command and it sends this command to the motion command generator, having the generator to execute the command. In the second ms, the PR queue receives a Write command and executes it immediately. In the third ms, the PR queue receives a Jump command and executes it immediately as well. These last two commands are not sent to the motion command generator since the PR queue and the generator can execute commands independently. In the fourth ms, the PR queue receives a Position command. After the first Position command is complete, the PR executor sends it to the generator and the generator starts executing it immediately.

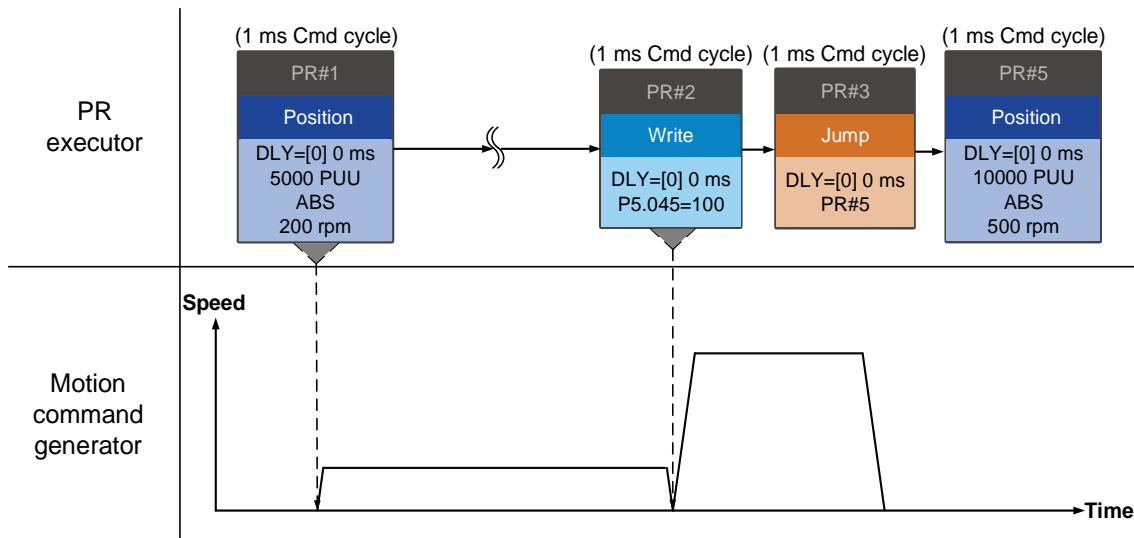

Figure 7.1.6.4 Multiple sequence commands

## Command interruption

Interruption (INS) causes a command in execution to be replaced or integrated. The results of the interruption differ based on the command types. The next command replaces or combines with the previous command. There are two types of interruption: internal and external, as shown in Figure 7.1.6.5.

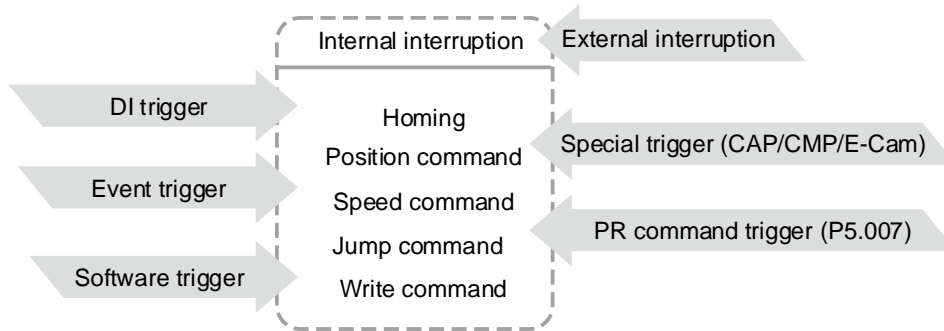

Figure 7.1.6.5 Internal and external interruption

### 1. Internal Interruption

For a series of PR paths, if one PR path includes an AUTO function (auto-execute the next path), the system reads the next path after reading the current path. If the current path includes a delay, the next path is read after delay time is over. Meanwhile, if the next path includes an Interrupt function (which has a higher execution priority), the servo drive immediately executes the interrupt command. It replaces the un-executed part in the previous path with the next or integrates the command in the execution of the previous path with the next.

#### ■ Position command ► Position command (I) ► Position command

When the PR executor receives three consecutive Position commands with an interrupt in the second command, the executor treats the first and the second Position commands as one PR group. Since the first Position command is not executed, the executor replaces the first command with the second. It only sends the second command to the motion command generator for execution. After the second command is complete, the executor sends the third command to the generator (see Figure 7.1.6.6 (a)).

If the first command includes a delay, then the PR executor sends the first command to the generator and then starts counting the delay time. After the delay is over, the PR executor then sends the second command and the generator starts the second part of position control. While the first command is still being executed, it is integrated with the second command. The integration is slightly different from what is described in Section 7.1.3. Refer to the following descriptions. Once the second command is complete, the executor sends the third command to the generator for execution (see Figure 7.1.6.6 (b)).



7

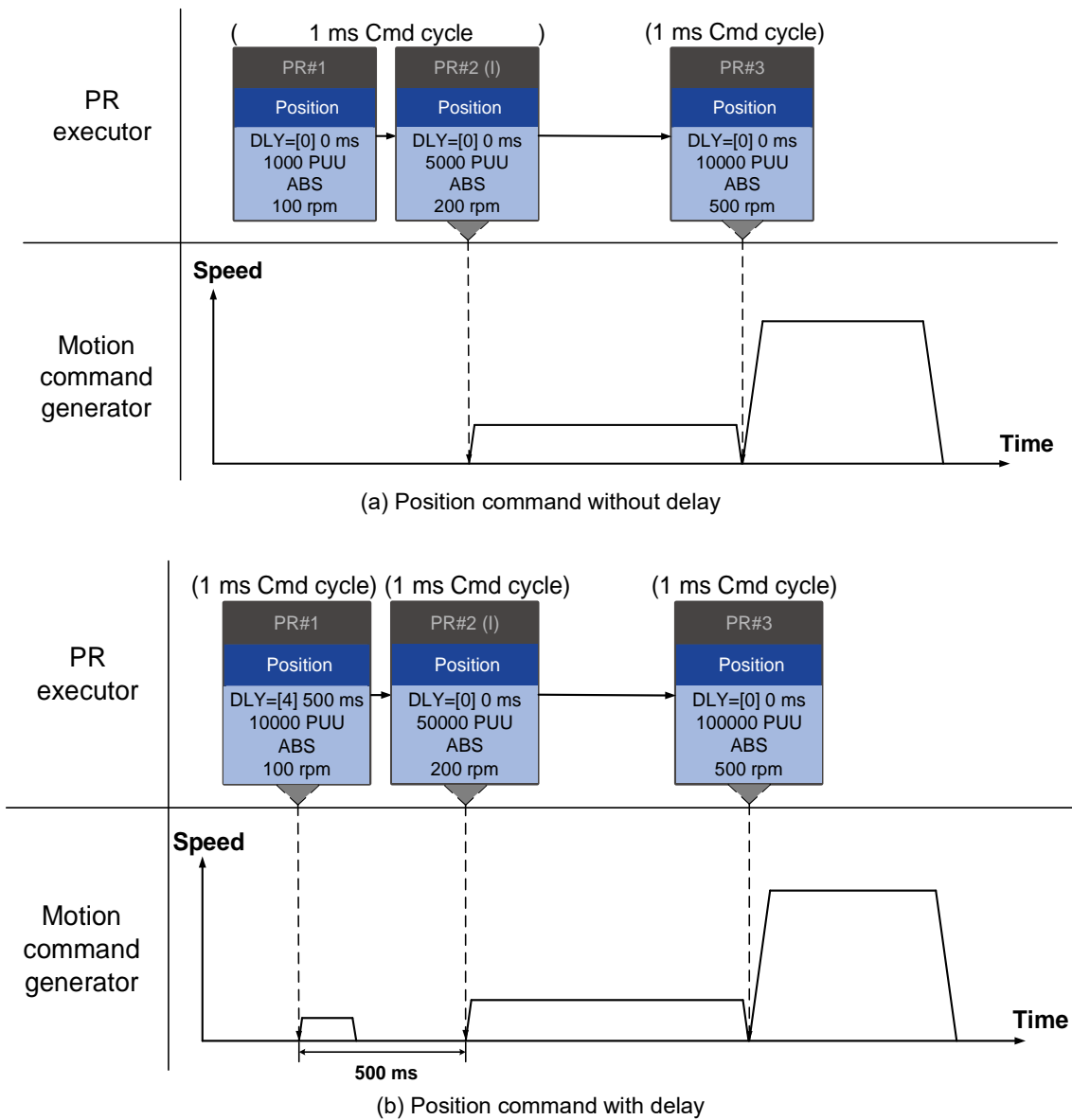

Figure 7.1.6.6 Internal interruption - Position command

The integration for internal interrupt position command is slightly different from what is described in Section 7.1.3. The way REL and INC commands work is identical. The target position is the previous target position plus the current position. See the following example. The rest of the integration method is the same as mentioned in Section 7.1.3.

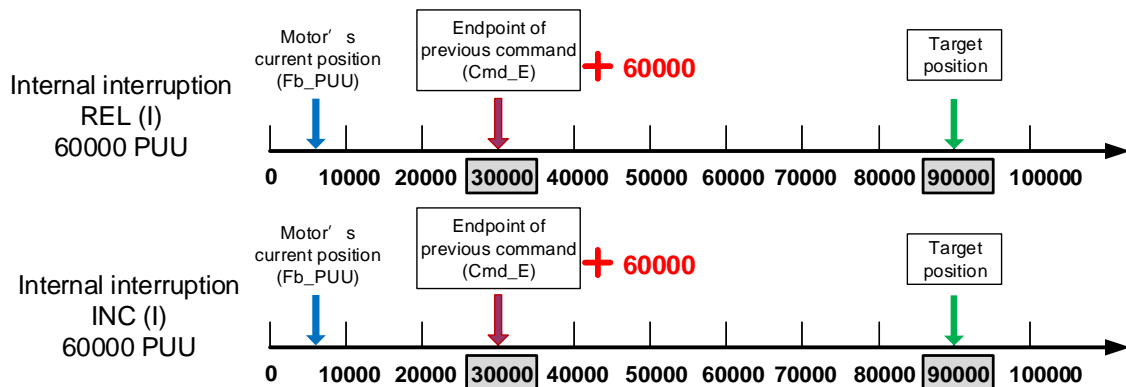
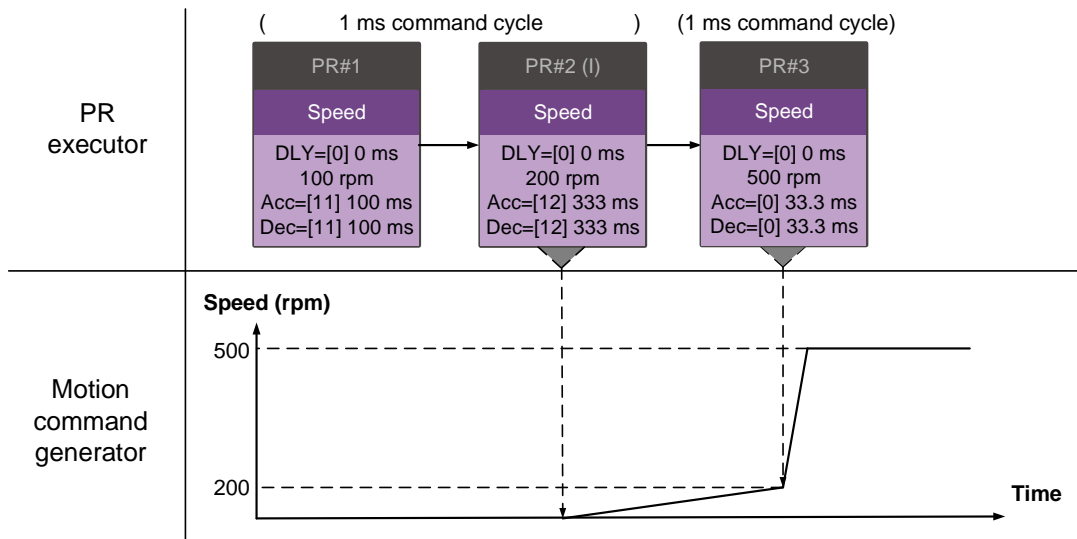

Figure 7.1.6.7 Example of relative and incremental position commands for internal interruption

■ Speed command ► Speed command (I) ► Speed command

When the PR executor receives three consecutive Speed commands with an interrupt in the second command, the executor treats the first and the second as one PR group. Since the first Speed command is not executed, the executor replaces the first command with the second. It only sends the second command to the motion command generator for execution. After the second command is complete, the executor sends the third command to the generator (see Figure 7.1.6.8 (a)).

If the first command includes a delay, then the PR executor sends the first command to the generator and then starts counting the delay time. After the delay is over, it then sends the second command and the generator starts the second part of speed control. While the first command is still being executed, it is integrated with the second command. Once the second command is complete, the executor sends the third to the generator for execution (see Figure 7.1.6.8 (b)).



(a) Speed command without delay

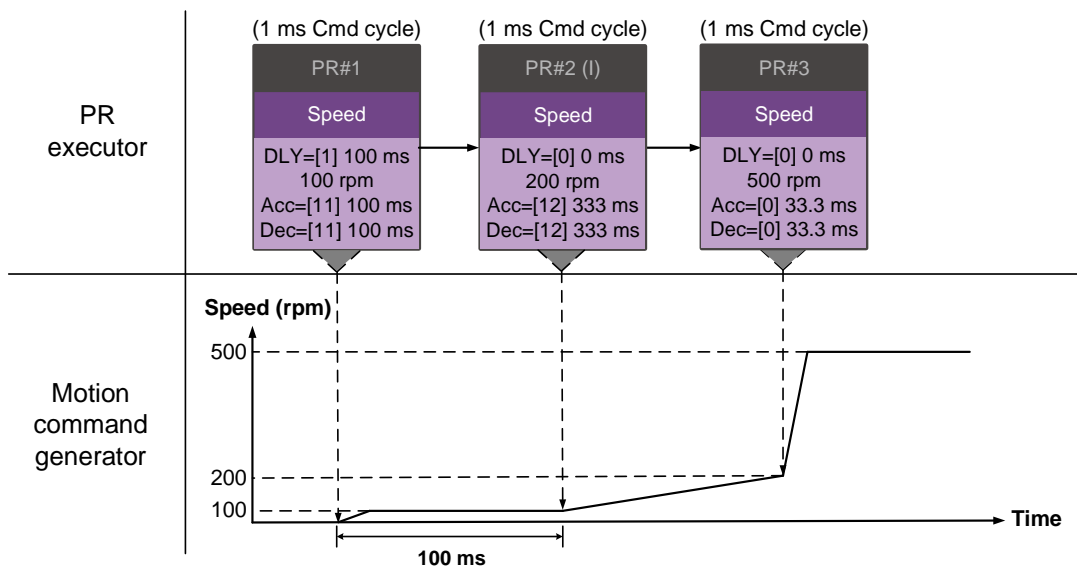

(b) Speed command with delay

Figure 7.1.6.8 Internal interruption - Speed command

# 7

■ Multiple interrupt commands

The PR queue updates commands every 1 ms. If all PR paths include an Interrupt function, the queue can read at least 20 PR paths in 1 ms, and these paths are called a PR group.

If this PR group has multiple motion commands, the PR queue only sends the last command it receives to the motion command generator for execution. Therefore, in a PR group, only one PR path with motion command is executed. The latter motion command directly replaces the former, whereas Jump and Write commands are executed as soon as they are received by the PR queue (see Figure 7.1.6.9 (a)). If one of the PR paths includes a delay, the PR queue schedules all paths on the basis of this PR path and regards the prior path(s) (including the PR path which includes a delay) as the first PR group, and regards what follows as the second PR group. Thus, this PR procedure can execute up to two PR paths with motion commands, as shown in Figure 7.1.6.9 (b).

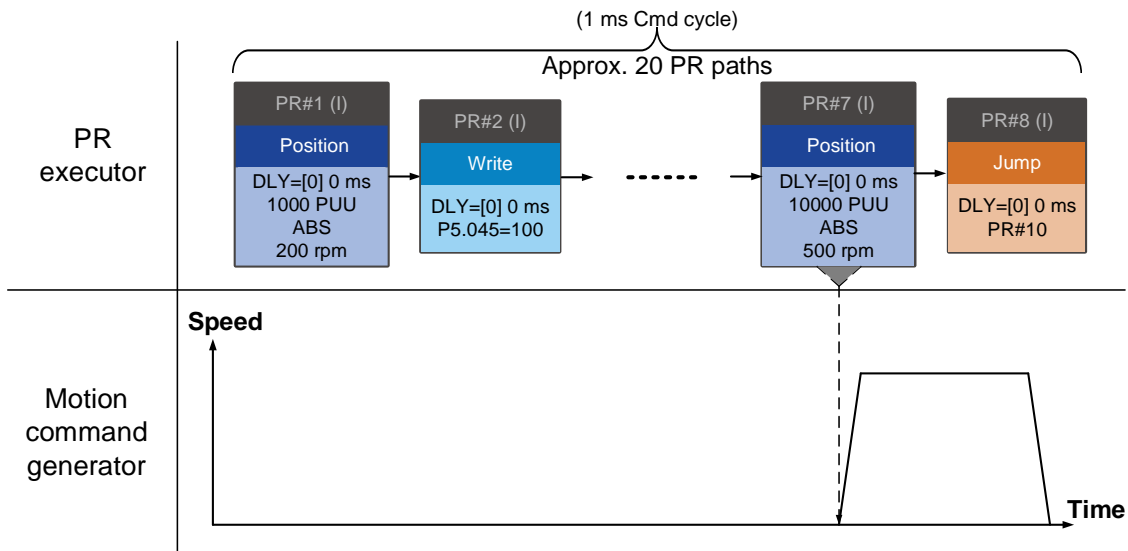

(a) Multiple commands without delay

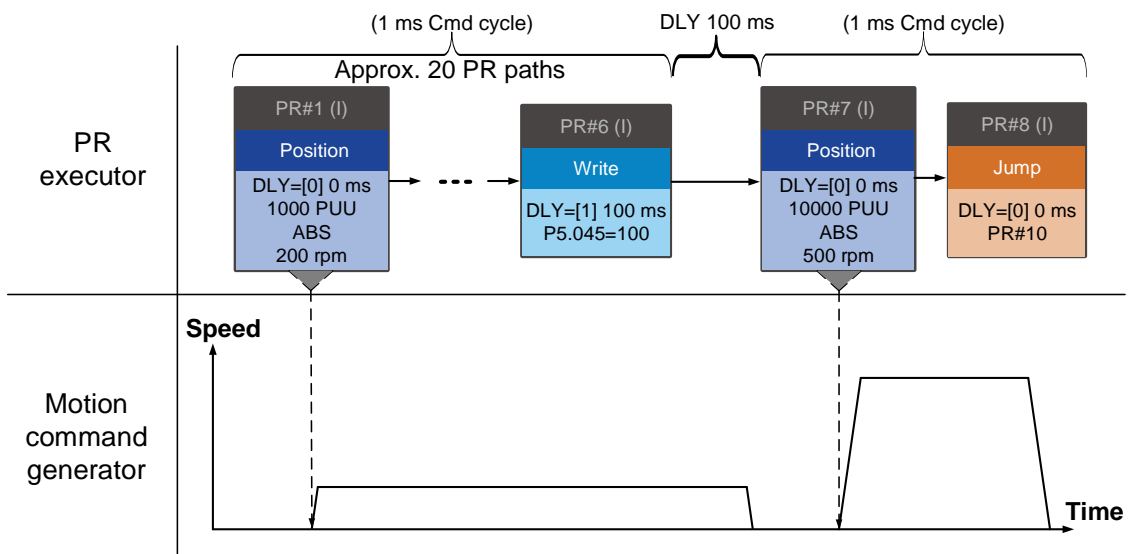

(b) Multiple commands with delay

Figure 7.1.6.9 Internal interruption - Multiple commands

2. External Interruption

If an external interruption is encountered, it uses the PR Command trigger method to execute another PR path (refer to Section 7.1.5 for PR trigger methods). When the PR queue receives a PR path with an Interrupt function, it sends this path to the motion command generator immediately and changes the path in execution. Note that a delay does not change the result of an external interruption. That is, once the PR queue receives an external interrupt command, the motion commands in the latter part are executed by the generator and integrated with the previous commands.

The external interruption is as shown in Figure 7.1.6.10 (a). If a PR path with external interruption enters the PR executor, the executor sends this Position command immediately to the generator so that the motor can run in accordance with the interruption. The motor uses the settings that integrate with the former motion commands when running. The methods of integration are described in Section 7.1.3. Similarly, an external interruption affects Speed and Position commands the same way, as shown in Figure 7.1.6.10 (b). And the same is true for multiple commands.

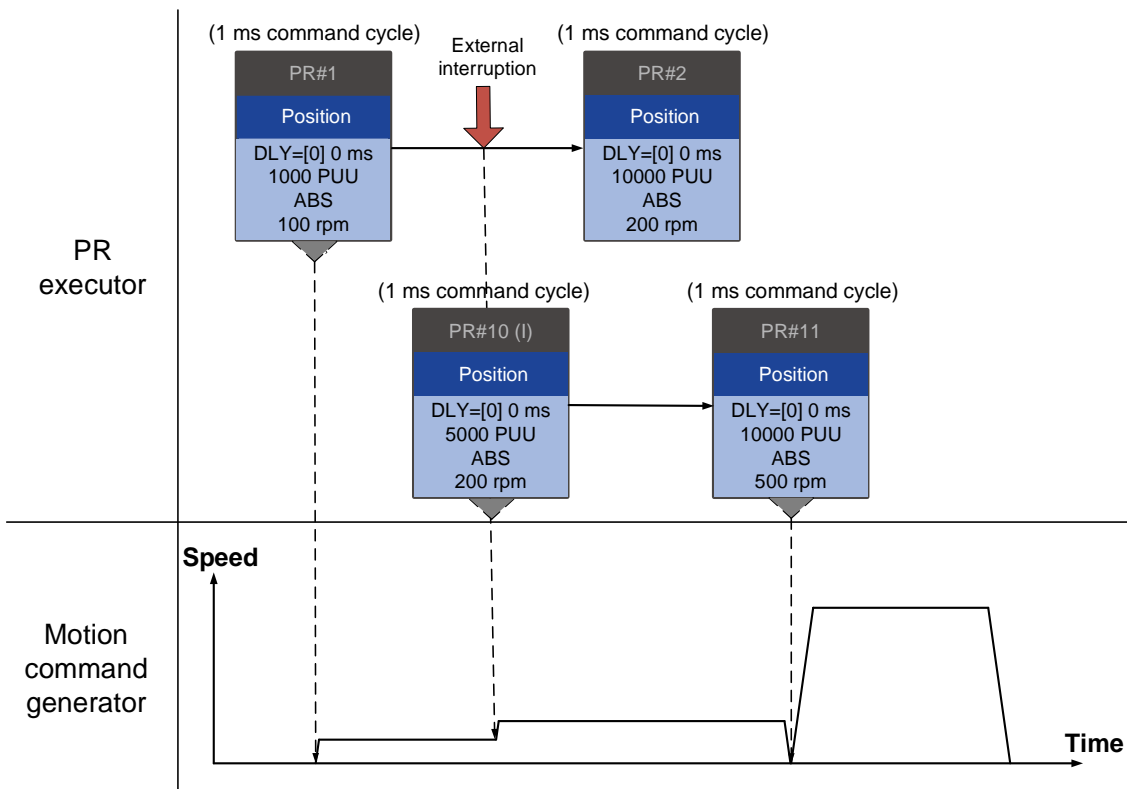

(a) External interruption - Position command

7

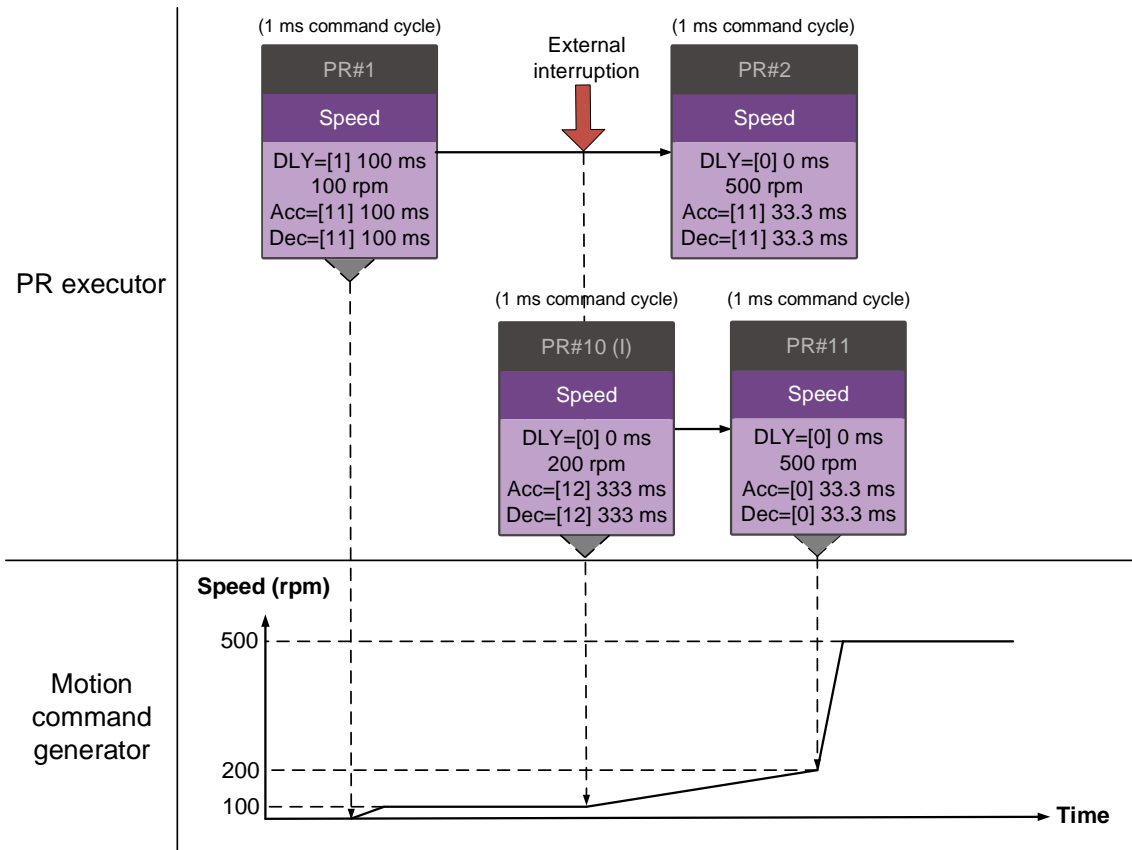

(b) External interruption - Speed command

Figure 7.1.6.10 External interruption

**Command overlapping**

If the previous position command includes an Overlap function, it allows the next command to be executed while the previous motion is decelerating, thus achieving a continuous motion. When you use a command with an Overlap function, the delay time is still effective. The delay time starts to count from the command's start point; however, in order to have the commands transition smoothly, setting the delay time of the previous command to 0 is suggested. In addition, if deceleration time of the previous command is identical to acceleration time of the next, the transition between commands can be very smooth, avoiding discontinuous speed during transition (see Figure 7.1.6.11). The calculation is as follows.

$$\frac{1st\ target\ speed\ (Spd1)}{3000} \times Deceleration\ time\ (Dec)$$

$$= \frac{2nd\ target\ speed\ (Spd2)}{3000} \times Acceleration\ time\ (Acc)$$

Commands that include an Interrupt function have a higher priority than commands that include an Overlap function. Thus, when you set an Overlap function in the current Position command, and the next motion command includes an Interrupt function, only the command with the Interrupt function is executed.

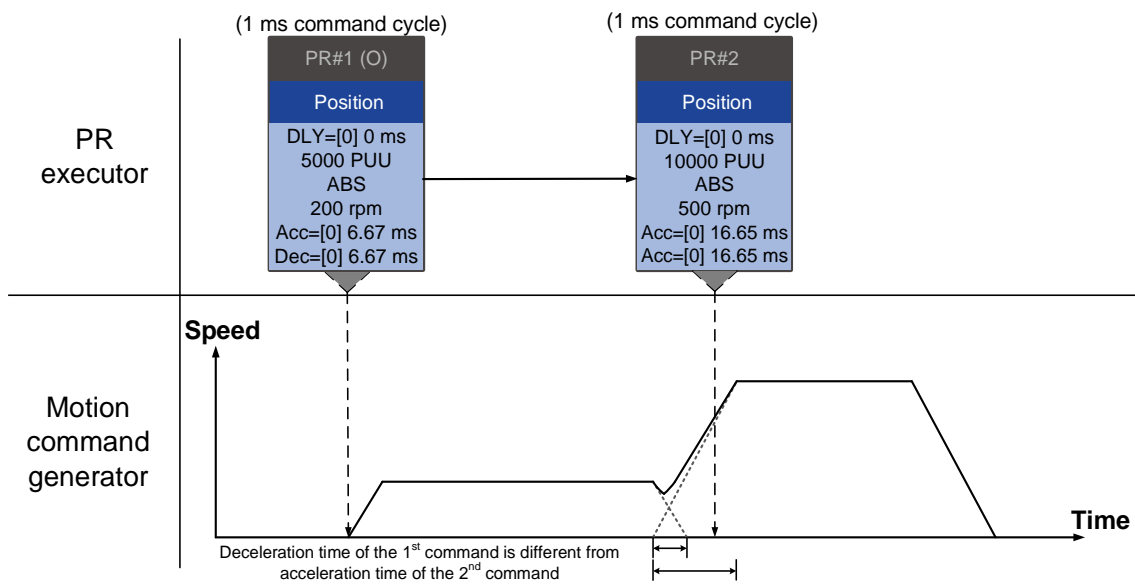

(a) Command overlapping - Acceleration and deceleration time are different

7

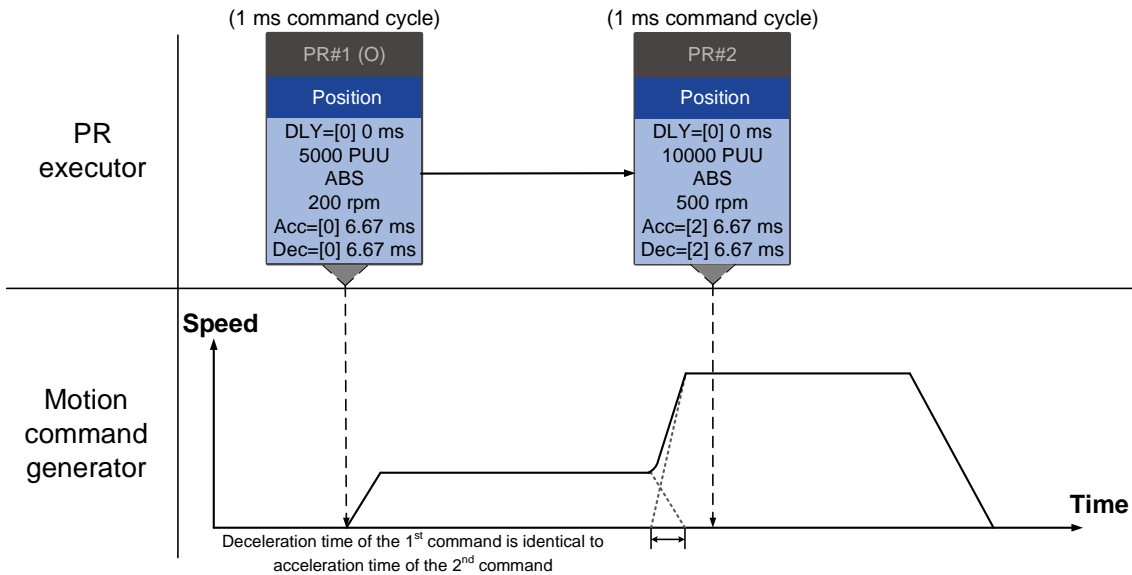

(b) Command overlapping - Acceleration and deceleration time are identical

Figure 7.1.6.11 Command overlapping

**Interpret PR path flow**

The PR paths mentioned earlier include commands such as Sequence, Interrupt, and Overlap. The replacement, integration, and overlapping for commands have different behavior depending on the settings. The suggested steps to interpret the PR path is as follows.

1. Check the command sequence. Check whether there are delay time (DLY) and interrupt (INS) settings because these two types change the command execution sequence.
2. Find the lead PR and identify each PR group of 1 ms.
3. In each PR group of 1 ms, only the last motion command is executed. The Jump and Write commands are immediately executed in the PR executor.
4. Position commands are combined based on the principle described in Section 7.1.3.3.

**Statement (Arithmetic operation)**

You can regard Statement commands as combinations of Write commands and Jump commands. Thus, the execution priority of Statement commands is the same as these two types of commands, which are executed by the PR executor. Statement commands can interrupt the previous command but cannot be interrupted by the following command. This ensures that all statements are executed before the PR paths enter the PR queue. In addition, whether there is an interrupt command in the next PR path determines the statement execution duration in the command cycle. If the following PR has no interruption setting (see Figure 7.1.6.12), the arithmetic operation only takes 3.89  $\mu$ s, but it still takes a complete cycle of 1 ms. The Jump PR number in the Statement is executed in the next ms. If the Jump PR number specified in the Statement has the interruption setting (as shown in Figure 7.1.6.13), this Jump command is executed only when the Statement is completely executed (which is after 3.89  $\mu$ s). Using P5.007 to trigger other PR paths is not applicable in the arithmetic operation area in the Statement.

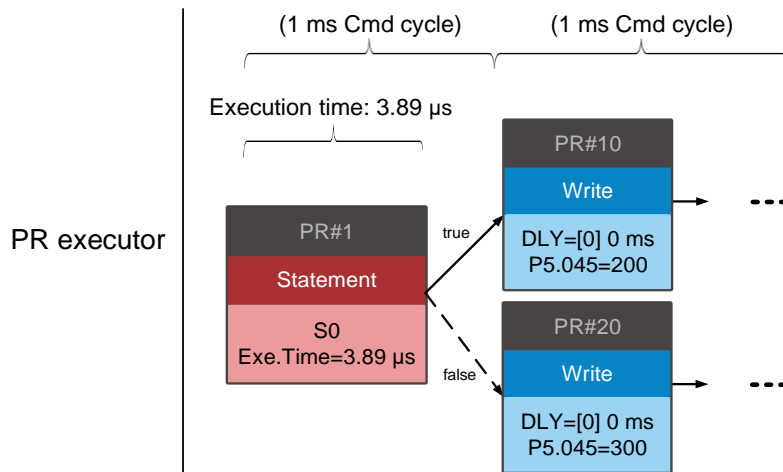

Figure 7.1.6.12 Multiple commands with arithmetic operations  
(followed by a PR path without interrupt command)

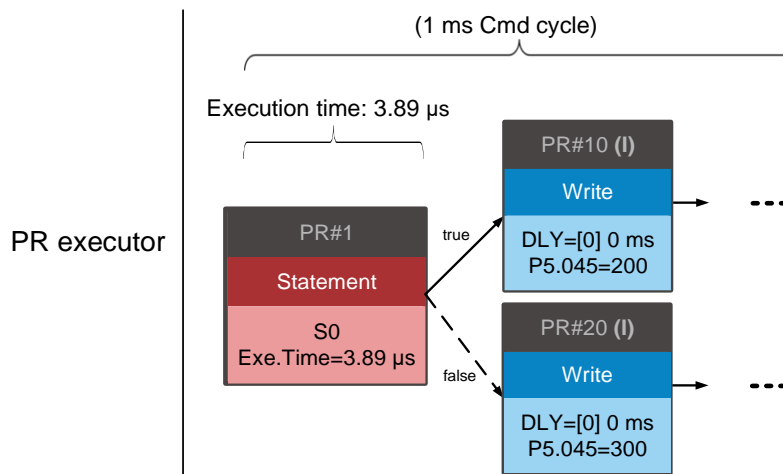

Figure 7.1.6.13 Multiple commands with arithmetic operations  
(followed by a PR path with interrupt command)

7



7

## 7.2 Application of motion control

Applications of motion control in the ASDA-A3 include high-speed position capture (Capture), high-speed position compare (Compare), and E-Cam. High-speed position capture uses digital input (DI7) to instantly capture the motor’s feedback position and stores this position in the data array. For high-speed position compare, it writes the specified motor position to the data array and outputs a high-speed digital signal (DO4) once the motor feedback position reaches this specified position. The purpose of E-Cam is to create an E-Cam curve according to the correlation between the Master and the Slave, and then store the curve in the data array. The Slave axis refers to the Master axis’ position and moves to the position specified by the E-Cam. You can find more details about the setting and how it works in the following sections.

### 7.2.1 Data array

The data array can store up to 800 sets of 32-bit data (0 - 799). You can use it to store the high-speed position capture data and high-speed position compare data as well as the E-Cam curves.

To prevent overwriting or accidentally changing any data, properly segment the space for these three functions as their individual spaces are not defined by default. Set P2.008 to 30 and then 35 or use ASDA-Soft to write the data to EEPROM; otherwise, the data in RAM is not saved after you turn the power off. ASDA-Soft includes a user-friendly screen for reading and writing the data array. See the following figure.

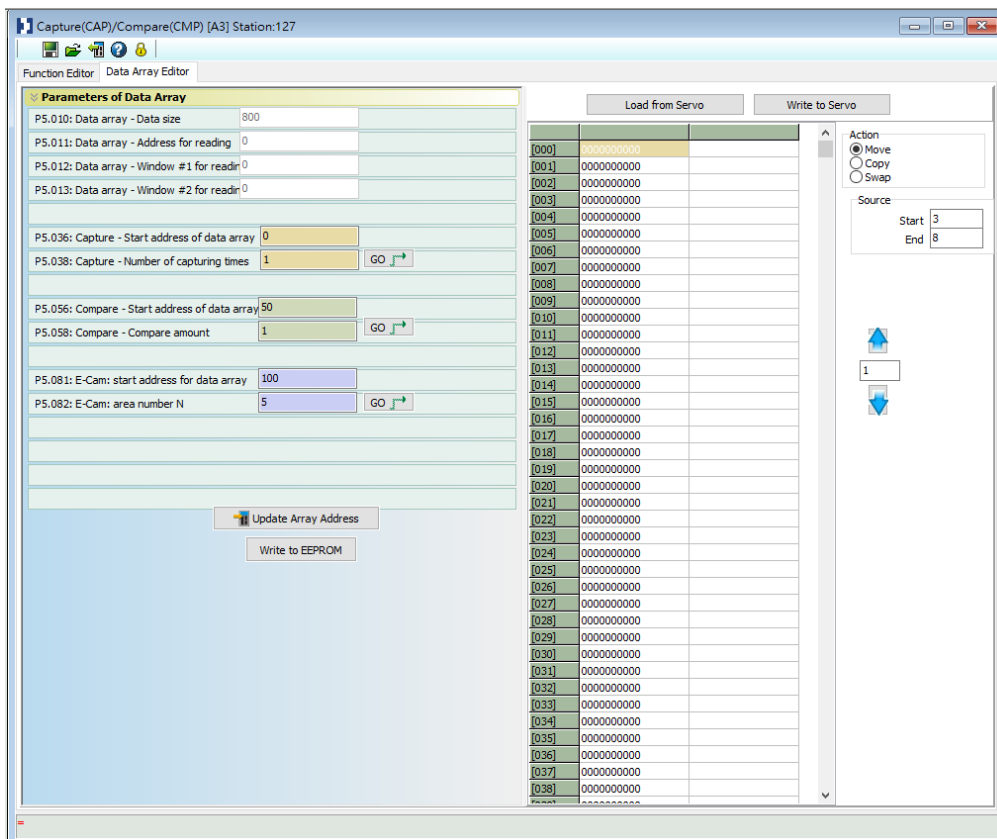

Figure 7.2.1.1 Data Array screen in ASDA-Soft

You can use the panel, communication, or ASDA-Soft to read data from or write data to the data array. Regardless of the methods, they are completed by parameter settings. The first parameter group for reading and writing the data array is P5.011, P5.012, and P5.013. P5.011 specifies the address for reading and writing the data array. P5.012 and P5.013 are for reading and writing the actual data contents. The behaviors after reading and writing differ depending on the method you use to set the parameters. Refer to Table 7.2.1.1 for more information. The second parameter group for reading and writing the data array is P5.100 and P5.100 - P5.103. P5.100 specifies the address for reading and writing the data array. P5.100 reads data from or writes data to the data array address set by P5.011. P5.101 reads data from or writes data to the data array address following the address set by P5.011. P5.102 and P5.103 work the same way. If the address value accumulates and exceeds the maximum of 799, the return address is 0. You can find more details in Table 7.2.1.2.

Table 7.2.1.1 Group 1 - reading and writing the data array

Parameter	Description		
P5.011 Address for reading / writing	Specify the address for reading from or writing to the data array		
Window for reading / writing	by	Behavior after reading	Behavior after writing
P5.012 Window #1 for reading / writing	Panel	<b>Value of P5.011 does not add 1</b>	Value of P5.011 adds 1
	Communication / ASDA-Soft	Value of P5.011 adds 1	Value of P5.011 adds 1
P5.013 Window #2 for reading / writing	Panel	Value of P5.011 adds 1	<b>Cannot be written with the drive panel</b>
	Communication / ASDA-Soft	Value of P5.011 adds 1	Value of P5.011 adds 1

- Example: when using the drive panel or communication for reading from or writing to the data array, write values to the data array address in sequence as follows: Data array #11 = 100, Data array #12 = 200, Data array #13 = 300. Then the data is read in sequence.

1. Read / write with panel:

7

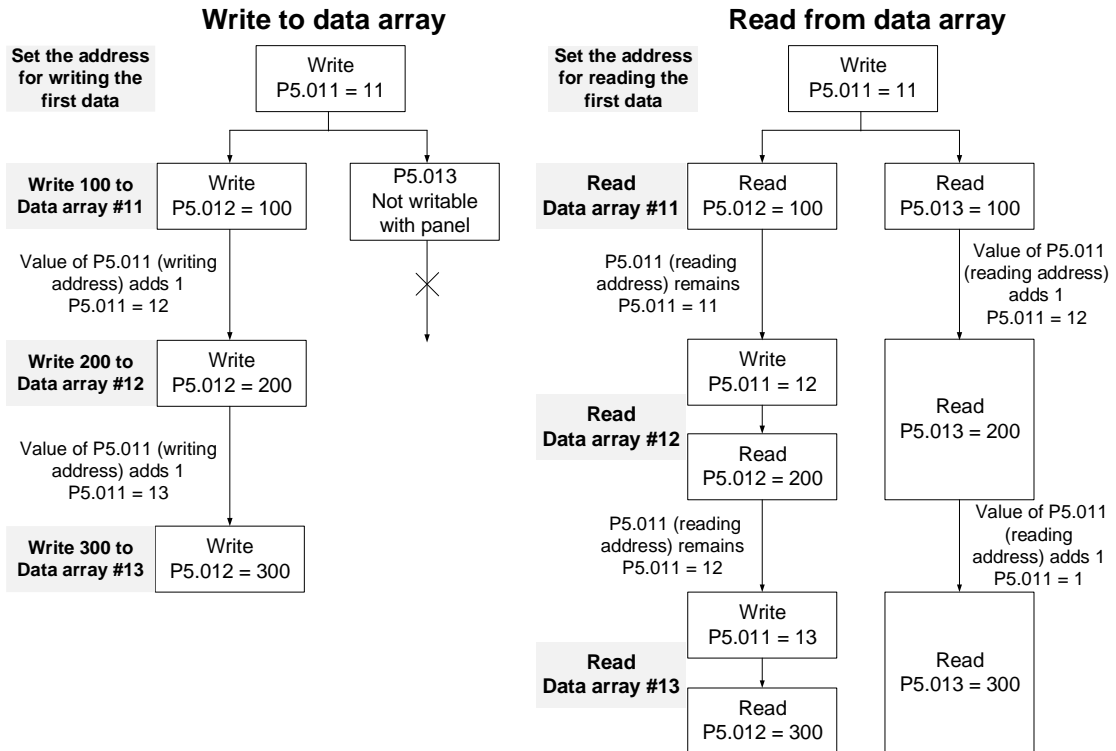

## 2. Read / write with communication:

To read from or write to the data array through Modbus, use the communication command 0x10 to write consecutively, 0x06 to write single data, and 0x03 to read consecutively. First, use a consecutive writing command to write 100 to Data array #11, 200 to Data array #12, and 300 to Data array #13. When reading, use a single data writing command to set the start address as Data array #11, and then use a consecutive reading command to read P5.011 - P5.013 (Data array #11 and #12). This reads two values, so P5.011 is incremented by 2 and then it reads Data array #13.

Writing to the data array									
Packet	Communication Cmd	Start address	Data size	P5.011		P5.012		P5.013	
				Low bit	High bit	Low bit	High bit	Low bit	High bit
1	0x10	P5.011	6 words	11	0	100	0	200	0
2	0x10	P5.011	6 words	13	0	300	0	0	0
Reading the data array									
Packet	Communication Cmd	Start address	Data size	P5.011		P5.012		P5.013	
				Low bit	High bit	Low bit	High bit	Low bit	High bit
4	0x06	P5.011	-	11	0	-	-	-	-
5	0x03	P5.011	6 words	11	0	100	0	200	0
6	0x03	P5.011	6 words	13	0	300	0	0	0

Table 7.2.1.2 Group 2 - reading and writing the data array

Parameter	Description	Example 1		Example 2	
P5.011 Address for reading / writing	Specify the address for reading from or writing to the data array	200		797	
Window for reading / writing	Description	Example 1		Example 2	
		Address	Content	Address	Content
P5.100 Window #3 for reading / writing	Read from or write to the address specified by P5.011.	200	1234	797	5678
P5.101 Window #4 for reading / writing	Read from or write to the first address following the address specified by P5.011.	201	2345	798	6789
P5.102 Window #5 for reading / writing	Read from or write to the second address following the address specified by P5.011.	202	3456	799	7890
P5.103 Window #6 for reading / writing	Read from or write to the third address following the address specified by P5.011.	203	4567	x	0

## 7.2.2 High-speed position capture function (Capture)

The high-speed position capture function (CAP) uses the external-triggered high speed digital input DI7 (with execution time of only 5  $\mu$ s) to capture the position data of the motion axis and store it in the data array for further motion control. As the Capture function is executed by the hardware, there is no lag in the software, and it is able to capture the motion axis' position accurately. While the Capture function is enabled, the servo drive sends a DI7 signal for the capture signal (DI7 is not user-defined).

The flowchart for high-speed position capturing is shown in Figure 7.2.2.1. The relevant parameters are defined as follows. P5.036 sets the start position in the data array for storing the captured data; if it is not set, the default start position is #0. P5.038 sets the capturing amount. The amount has to be greater than 0, otherwise the Capture function is not executed. P1.019.X enables the cycle mode. When the last data is captured, the capturing amount is reset to 0 (P5.038 = 0), and the next cycle starts automatically to capture the set capturing amount. However, the start position for storing the captured position data is still determined by P5.036; that is, the captured data in the previous cycle is overwritten by the data captured in the next cycle. P5.039 enables and disables the Capture function and other settings. See the following table for more information. To capture multiple position data, use P1.020 to set the masking range for capturing. This prevents the same position data being captured repeatedly because capturing more than once is not allowed in the masked area. You can set the Capture function in ASDA-Soft, as shown in Figure 7.2.2.2.

P5.039	Bit	Function	Description
X	0	Enable Capture function	When P5.038 > 0 and Bit 0 = 1, the capturing starts and DO.CAP_OK is off. Each time a position is captured, the value of P5.038 is decremented by 1. When P5.038 = 0, it means the capturing is finished, DO.CAP_OK is on, and Bit 0 is reset to 0. If Bit 0 is already 1, the written value must not be 1; you must write 0 to disable the Capture function.
	1	Reset position when first data is captured	If Bit 1 = 1, after the first data is captured, set the Capture axis' position to the value of P5.076.
	2	Enable Compare function after first data is captured	If Bit 2 = 1, when the first data is captured, enable the Compare function (P5.059.X Bit 0 = 1 and P5.058 resets to the previous value). If the Compare function is already enabled, then this bit function is invalid.
	3	Execute PR#50 after the last data is captured	If Bit 3 = 1, execute PR#50 once all data are captured.
Y	-	Source of Capture axis	0: disabled 1: CN5 2: CN1 (pulse command) 3: CN2
Z	-	Trigger logic	0: NO (normally open) 1: NC (normally closed)
U	-	Minimum trigger interval (ms)	-

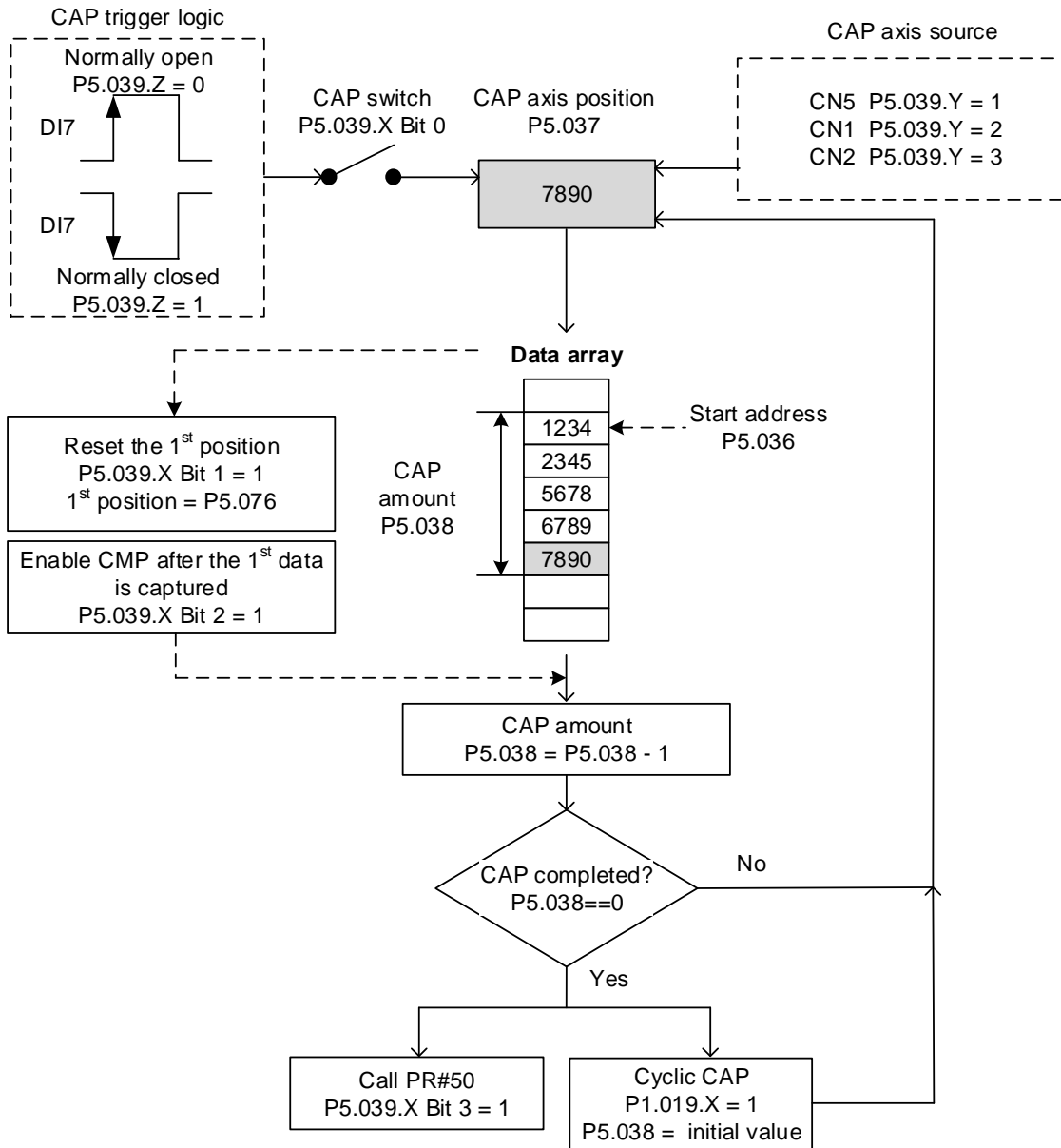

7

Figure 7.2.2.1 Flowchart for high-speed position capturing

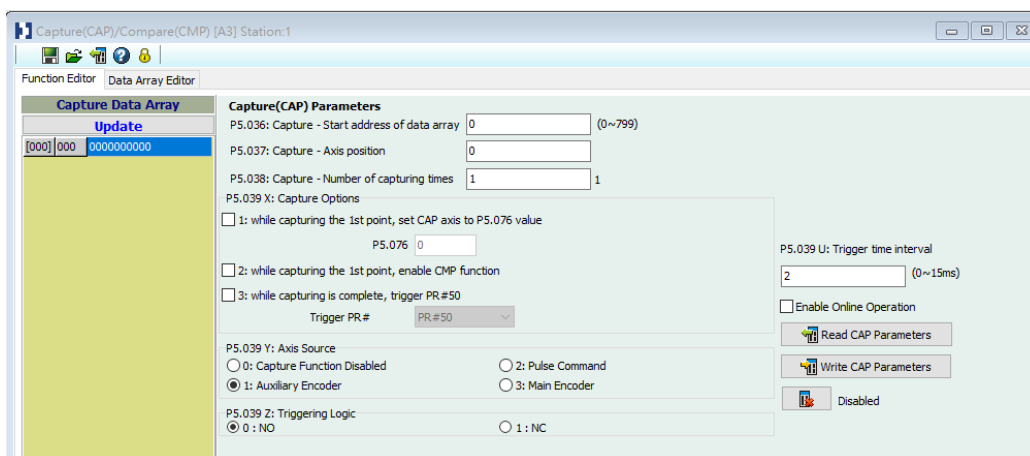

Figure 7.2.2.2 Capture function screen in ASDA-Soft

## 7

It is suggested that you use the PR path programming to use the motion commands with the Capture function. You can use Write commands to set the high-speed position capture function, as well as to execute motion commands once capturing is complete. See the example in Figure 7.2.2.3. PR#1 confirms that the Capture function is disabled (P5.039.X Bit 0 = 0). PR#2 sets the start position of data array to #100. PR#3 sets the capturing amount to 3. PR#4 sets the capturing axis' position to 0 for the first capture point. PR#5 sets the cyclic capture mode with delay time of 1 ms to ensure that the next PR path can be executed with the Capture function. PR#6 enables the Capture function and resets the first point; and once completed, continue executing PR#50. This selects CN2 as the capturing axis, using 'normally closed' contact as the trigger logic with a trigger interval of 2 ms. PR#7 sets the Speed command to 50 rpm. PR#50 sets the capture Position command to 50000 PUU. Once the command is complete, continue to PR#51 with the Speed command setting at 50 rpm.

From Figure 7.2.2.4, you can see that after DI7 is triggered, the capturing axis is reset to 0 and the data is stored in data array #100 because the Reset function for the first point is enabled and P5.076 is set to 0. At the moment DI7 is triggered the second and third time, the position data is written to the data array #101 and #102. Once the first capture cycle is complete, DO: [0x16]CAP is set to on and then PR#50 (high-speed position capture command) and PR#51 (motion with fixed speed) are executed. Then, the servo drive continues executing the next cycle; meanwhile, DO: [0x16] CAP is set to off when the procedure is complete and the capturing amount is set to 3. When DI7 is triggered for the fourth time, the capture axis' position is not reset; the position data of the capturing axis is written to #100 again. Therefore, the data written in the previous cycle is overwritten. At the moment DI7 is triggered the fifth and sixth time, the position data is written to the data array #101 and #102. Once the second capture cycle is complete, DO: [0x16]CAP is set to on and then PR#50 (high-speed position capture command) and PR#51 (motion with fixed speed) are executed again.

When in Cyclic Capture mode (P1.019.X = 1), the Reset function is only valid for the first cycle. Executing the PR path is valid for every cycle; in other words, every time a cycle ends, PR#50 is executed. The first position data captured in every cycle is written to the data array address set by P5.036, and then the other data is written in sequence. So, position data written in the previous cycle is always overwritten by the position data of the next cycle.

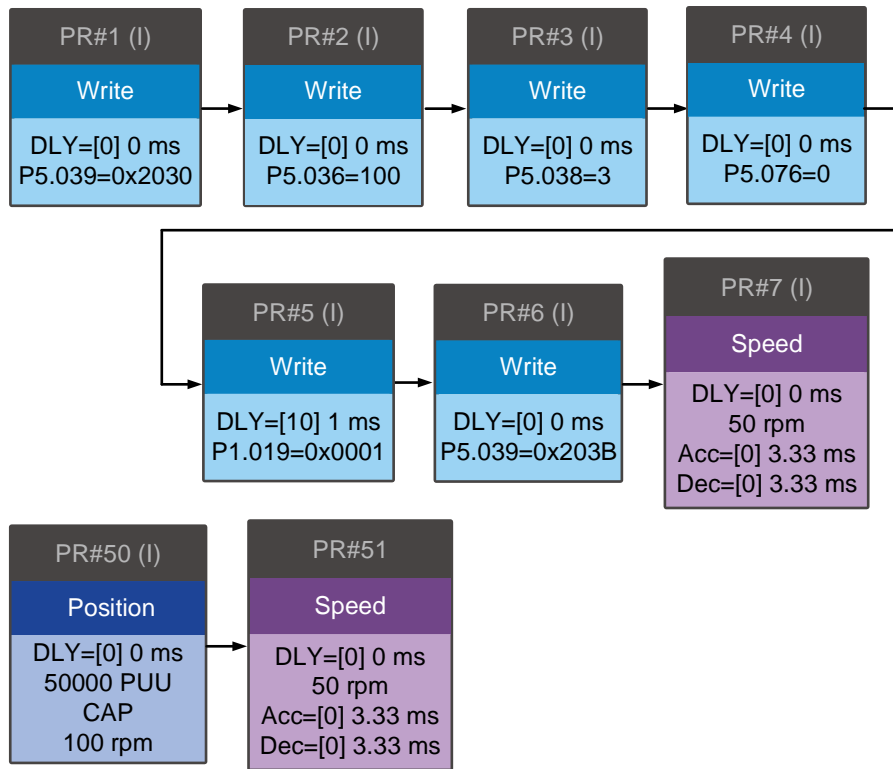

Figure 7.2.2.3 PR path with application of high-speed capture function

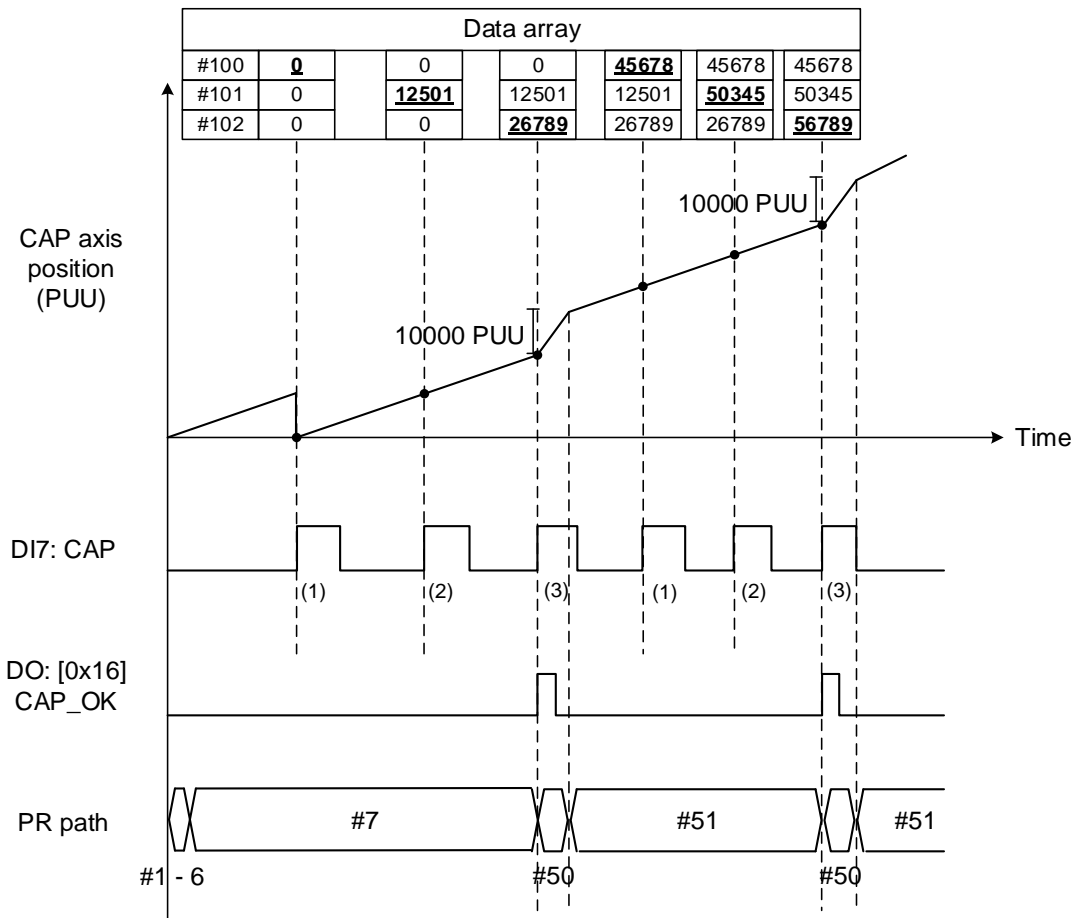

Figure 7.2.2.4 Application example for high-speed capture function



### 7.2.3 High-speed position compare function (Compare)

The high-speed position compare function (CMP) compares the instant position feedback of the motion axis with the value saved in the data array. When the compare condition is fulfilled, a high-speed digital output signal DO4 (with execution time of only 5  $\mu$ s) is sent immediately for motion control. As the Compare function is executed by the hardware, there is no lag in the software, and the position compare is more accurate on high speed motion axes. While the Compare function is enabled, the servo drive outputs a DO4 signal (DO4 is not user-defined).

As shown in Figure 7.2.3.1 Flowchart for the high-speed position compare function, P5.056 sets the start position in the data array for comparing (default is #50 in the data array). You must write the position data to be compared to the data array before comparing. P5.058 sets the comparing amount. The amount has to be greater than 0, otherwise the Compare function is not executed. P5.059 enables and disables the Compare function and other settings. See the following table for more information. Note that when the comparing source is CN2, the pulse resolution of the comparing axis is set by P1.046 (numerator) and P1.097 (denominator) with default values of 2500 and 0 respectively; that is, the moving distance of the comparing axis is 10000 PUU per motor revolution. The comparing position in the data array can be shifted using P1.023 (non-volatile) and P1.024 (volatile). You can set P1.019.Z to have P1.024 be reset to 0 automatically after the shift. You can also set the Compare function in ASDA-Soft, as shown in Figure 7.2.3.2.

P5.059	Bit	Function	Description
X	0	Enable high-speed position compare function	When P5.058 > 0 and Bit 0 = 1, the comparing starts. Each time a point is compared, the value of P5.058 is decremented by 1. When P5.058 = 0, it means the comparing is finished, and Bit 0 is reset to 0. If Bit 0 is already 1, the written value must not be 1; you must write 0 to disable the Compare function.
	1	Cycle mode	If Bit 1 = 1, after all comparing is complete, P5.058 resets to the setting value and then the compare procedure starts again.
	2	Enable Capture function after data compared	If Bit 2 = 1, after all comparing is complete, enable the Capture function (P5.039.X Bit 0 = 1 and set the previous value to P5.038 as the data size to be captured). If the Capture function is already enabled, then this bit function is invalid.
	3	Reset position for the comparing axis to 0	If Bit 3 = 1, set P5.057 to 0 once all comparing is complete, the position for the comparing axis is reset to 0.
Y	-	Source setting of comparing axis	0: capturing axis 1: CN5 2: CN1 (pulse command) 3: CN2 When the source of Compare is the Capture axis, the source of Capture (P5.039.Y) cannot be changed. If CN2 is selected as the source, the pulse resolution is determined by P1.046 and P1.097 (Encoder pulse number output setting).
Z	-	Trigger logic	0: NO (normally open); 1: NC (normally closed)
U	-	Trigger PR path	If Bit 0 = 1, PR#45 is triggered once the last data is compared.
CBA	-	Pulse output duration (ms)	-

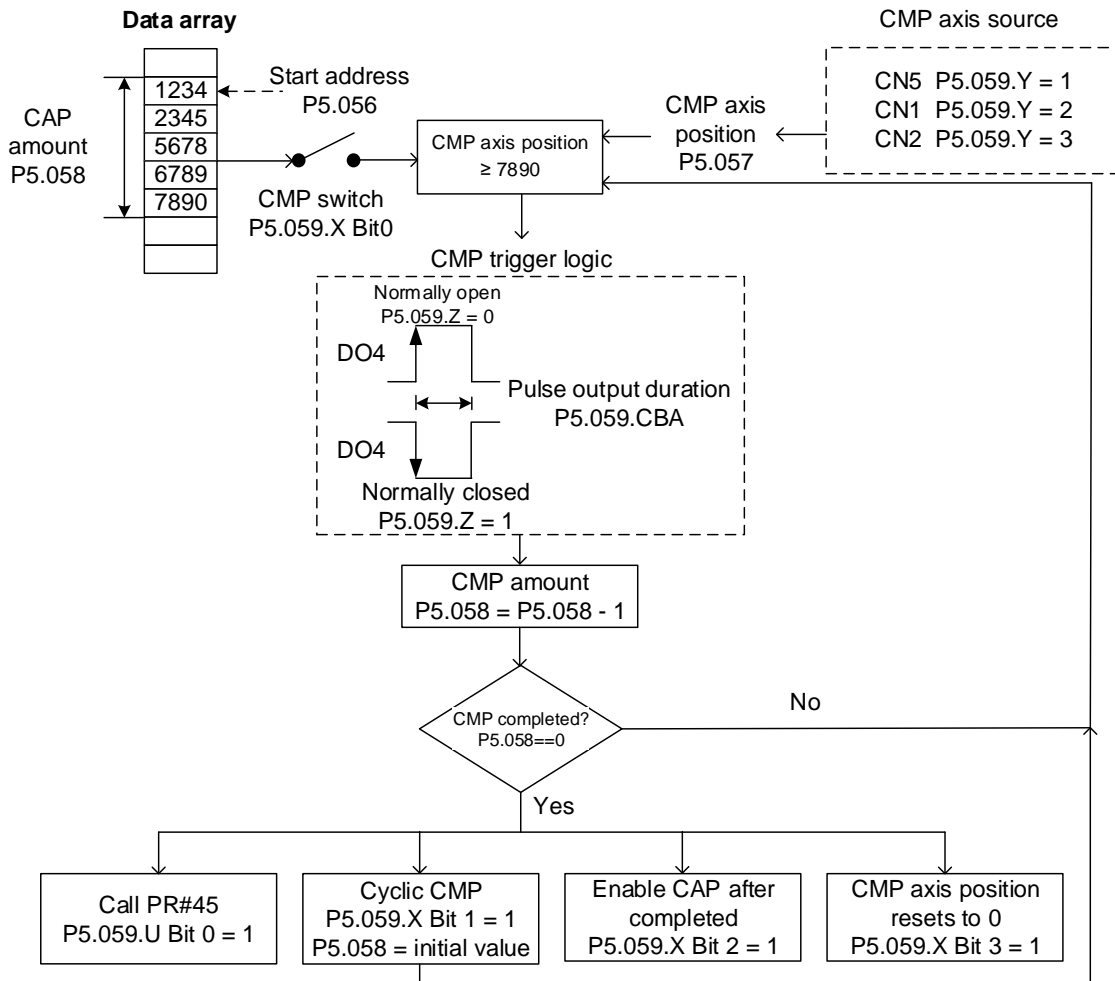

Figure 7.2.3.1 Flowchart for the high-speed position Compare function

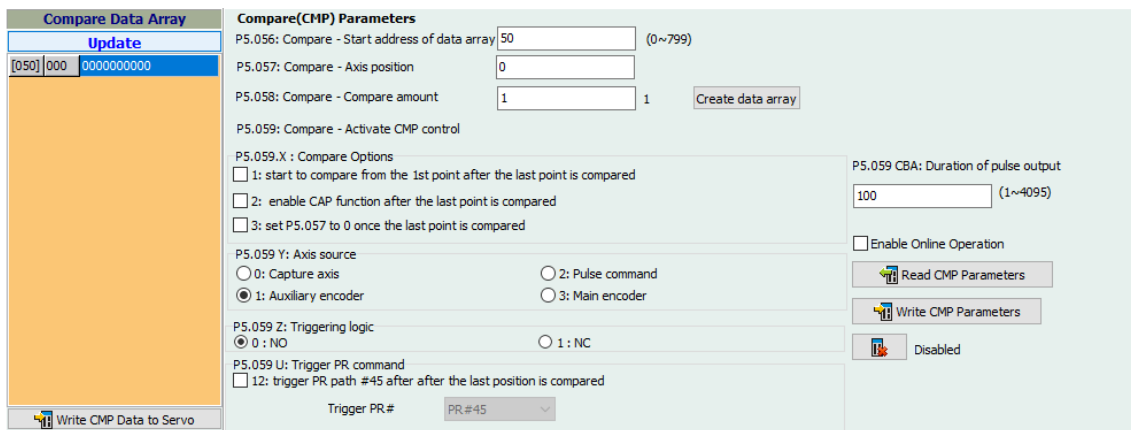

Figure 7.2.3.2 Compare Function screen in ASDA-Soft

7

## 7

It is suggested that you use PR path programming to use motion commands with the Compare function. You can use Write commands to edit the contents of the data array and set the high-speed position Compare function, as well as executing the motion command. As shown in Figure 7.2.3.3, you set the numerator (P1.046) and denominator (P1.097) for the encoder's pulse output (the default is based on the comparing axis running 10000 pulses per motor revolution). PR#1 - 3 use Write commands to edit data array #50 - 52. PR#4 confirms that the Compare function is disabled (P5.059.X Bit 0 = 0). PR#5 sets the start position to #50. PR#6 sets the comparing amount to 3. PR#7 resets the compare axis position to 0 and sets a delay of 1 ms to ensure that the next PR path with the Compare function can be executed. PR#8 enables the Compare function in Cycle mode which resets the comparing axis to 0 after the comparison is complete, and executes PR#45. It selects CN2 as the capturing axis source, setting 'normally closed' as the trigger logic with pulse output duration of 100 ms. PR#9 sets the Speed command to 50 rpm. PR#45 sets the Incremental command to 50000 PUU and then PR#46 keeps the Speed command setting at 50 rpm.

From Figure 7.2.3.4, you see that when the comparing axis runs to 20000 PUU, it is identical to the contents of data array #50 and the first DO4 is set to on. When the comparing axis runs to 30000 PUU, it is identical to the contents of data array #51 and the second DO4 is set to on. When the comparing axis runs to 40000 PUU, it is identical to the contents of data array #52 and the third DO4 is set to on. Once the first cycle completes, the comparing axis resets to 0 and executes PR#45 (Incremental command 50000 PUU), which is equivalent to a half turn of the motor. Therefore, the comparing axis outputs 5000 PUU, and after the position command completes, it executes the Speed command. Then the next comparing cycle starts. This is the same as the first cycle, and the comparing axis outputs DO4 signal at 20000, 30000, and 40000 PUU respectively and then it resets to 0 and executes PR#45.

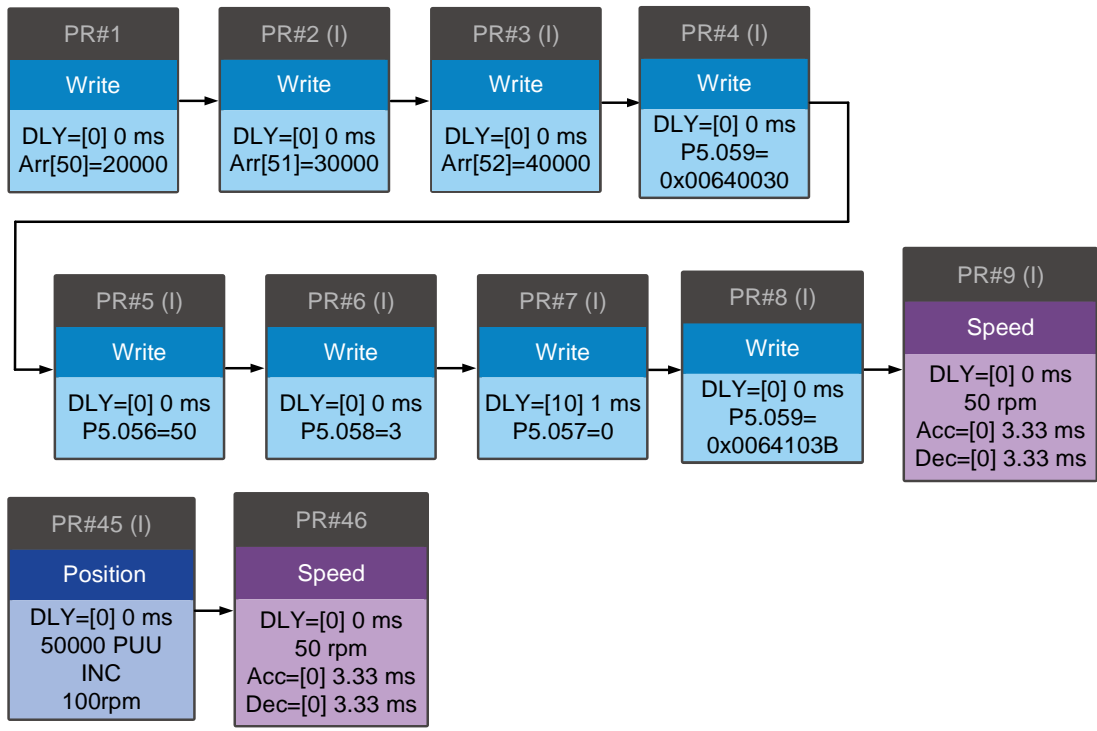

Figure 7.2.3.3 PR path using the Compare function

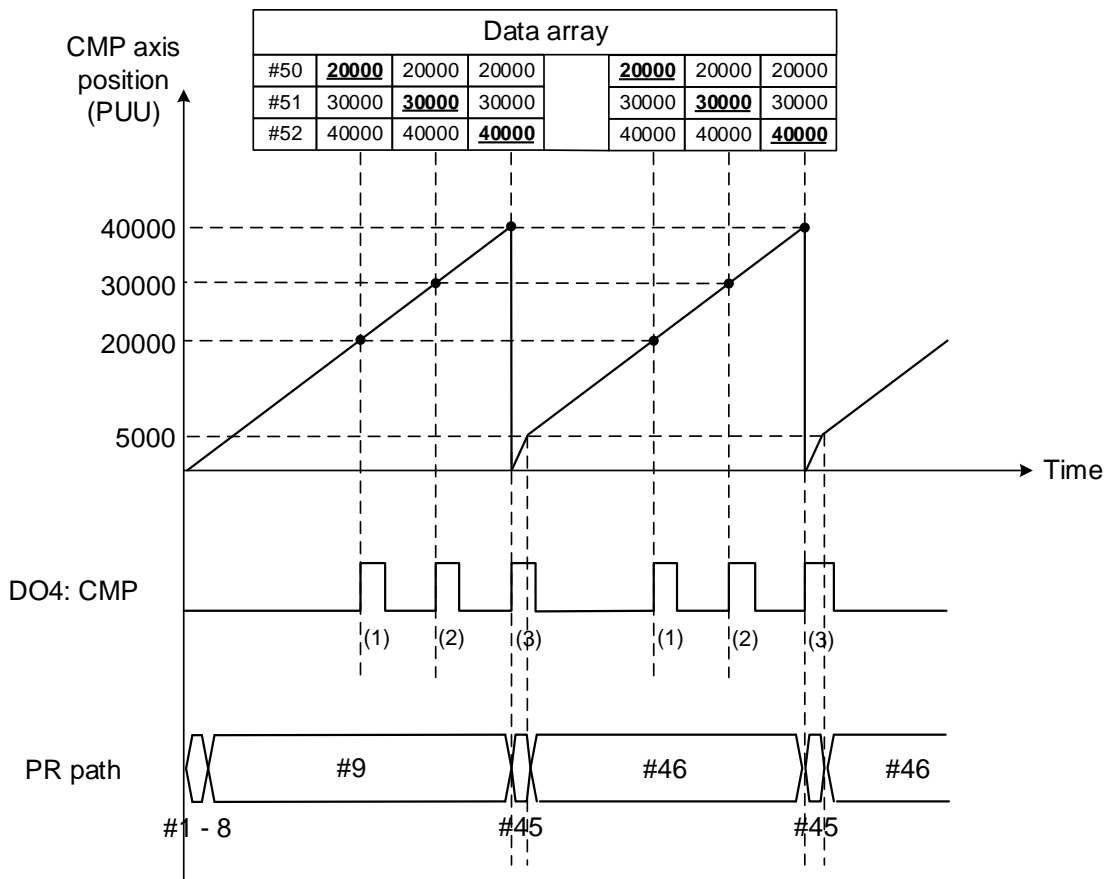
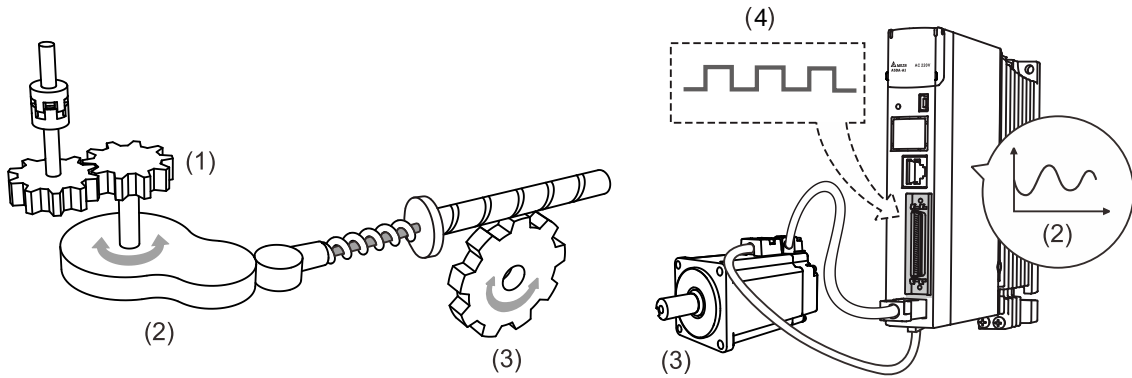

Figure 7.2.3.4 Timing of the Compare function

7

### 7.3 E-Cam

The E-Cam system uses the mathematical formula to plan the relative following motion path based on the master-slave operation, which can replace the mechanical cams instead of being limited to the mechanical cam shapes. You can use the E-Cam function as long as it is a master-slave application and their positions can translate into a mathematical formula. The mechanical cam and E-Cam are shown in Figure 7.3.1.



(1) Mechanical cam master axis input; (2) Cam curve; (3) Slave axis output; (4) E-Cam master axis input

Figure 7.3.1 Mechanical cam and E-Cam

The E-Cam function is only available in PR mode (P1.001 = 1). The slave axis operates based on the cam curve; the positions of the master and slave correspond to a mathematical function. The master axis sends pulses to the slave axis so the slave axis runs according to the corresponding E-Cam curve, as shown in Figure 7.3.2. Setting P5.088.X can enable or disable the E-Cam function. When this function is enabled, the servo drive determines the clutch engagement and disengagement timings. Figure 7.3.3 introduces the E-Cam parameters with a mechanical cam illustration. See the detailed settings in the following section.

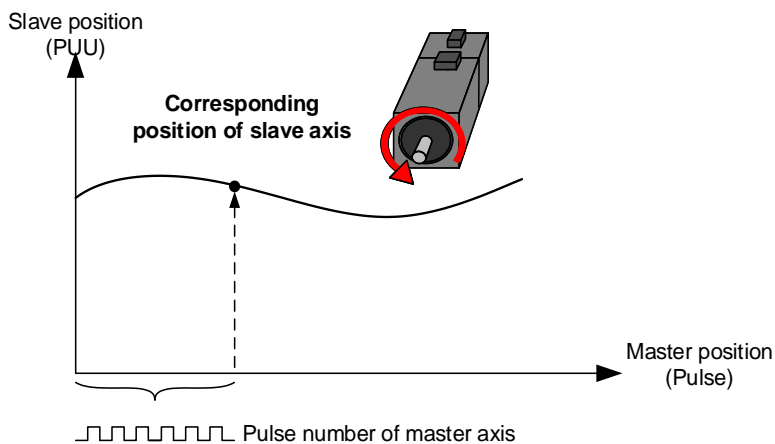
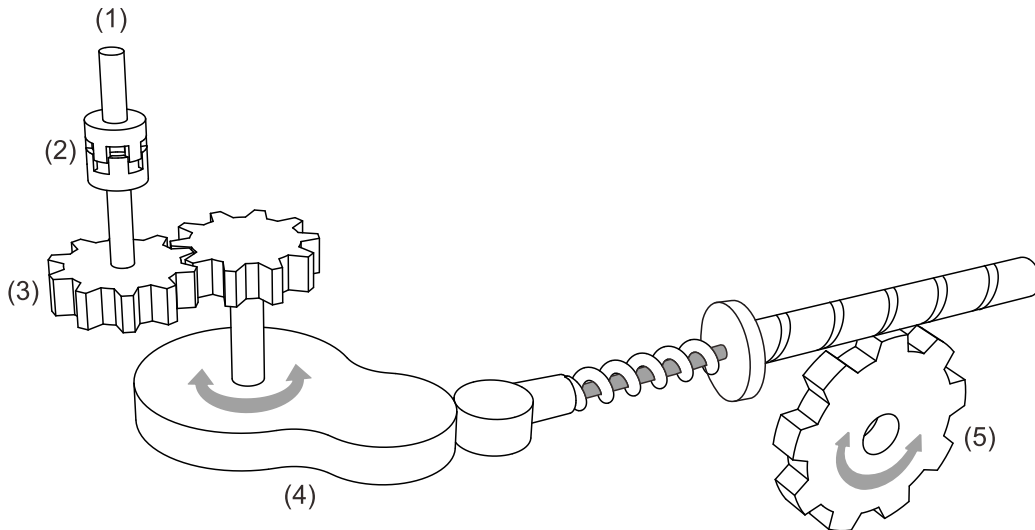

Figure 7.3.2 E-Cam curve



- (1) Master axis: P5.088.Y: command source for the master axis
- (2) Clutch: P5.088.UZ, P5.087, and P5.089: engagement and disengagement timing control
- (3) E-Gear of master axis: P5.083 and P5.084: command pulse resolution
- (4) E-Cam curve: P5.081, P5.082, and P5.085: position correlations of master and slave axes; P5.019: scaling
- (5) E-Gear of slave axis: P1.044 and P1.045: output signal resolution

Figure 7.3.3 Use E-Cam servo parameters to simulate mechanical cams

### 7.3.1 Source signal for the master axis

When using the E-Cam function, you must specify the signal source for the master axis, which can be the encoder, controller, or servo drive. The ASDA-A3 servo drives support seven source types for the master axis. You can select the master axis signal source with P5.088.Y and monitor the master axis position with P5.086.

1. Capture axis: when P5.088.Y = 0, the servo drive uses the source set in P5.039.Y (Capture function source) as the master axis signal source. You can read the value of P5.037 to acquire the master axis position.
2. Encoder: when P5.088.Y = 1, the servo drive uses CN5 external encoder signals as the master axis signal source. You can read the value of P5.017 to acquire the master axis position.
3. Pulse input: when P5.088.Y = 2, the servo drive uses pulses input through CN1 as the master axis signal source. You can read the value of P5.018 to acquire the master axis position.
4. PR command: when P5.088.Y = 3, the servo drive uses the PR motion control command as the master axis signal source.
5. Time axis (1 ms): when P5.088.Y = 4, the servo drive uses the pulse signal generated per ms as the master axis signal source.
6. Synchronous Capture axis: when P5.088.Y = 5, the servo drive uses the signals processed by the Capture function as the master axis signal source. This is mainly for adjusting the relative positions between the master and slave axes to keep all phases synchronous, such as mark tracking during cutting. Please refer to Section 7.3.7.

7. Analog speed channel: when P5.088.Y = 6, the servo drive uses the analog speed command as the master axis signal source; 10V corresponds to the frequency of 1 M pulse/s.

7 ASDA-A3 provides two DOs, [0x18] CAM\_AREA1 and [0x1A] CAM\_AREA2, which specify the current E-Cam operation position (in respect of the master axis). The first one is set by P5.090 and P5.091; the second one is set by P2.078 and P2.079, as shown in Figure 7.3.1.1. For detailed settings, refer to Chapter 8.

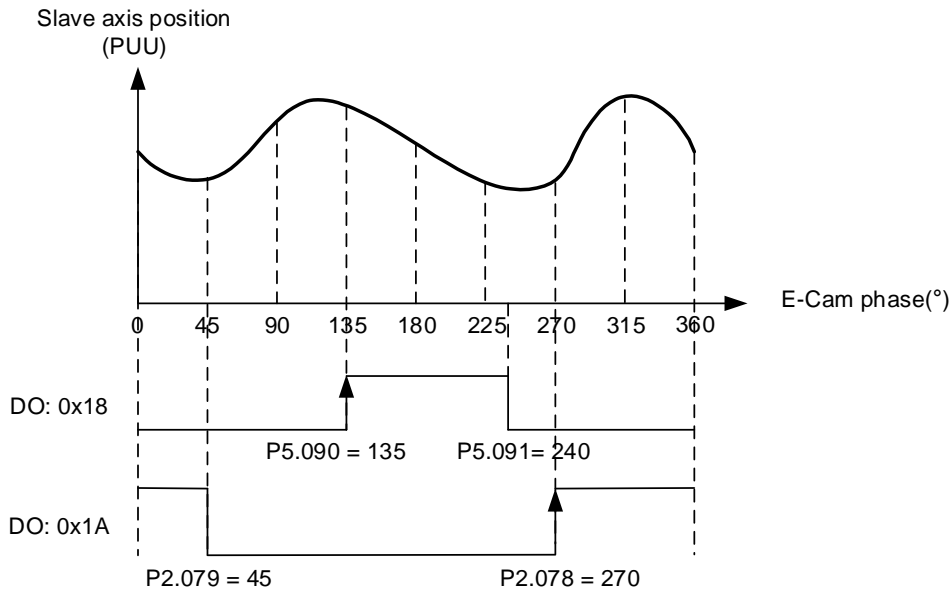

Figure 7.3.1.1 DO is on when the clutch engages

To get the data for the master axis, use four monitoring variables, which are Accumulative pulse of master axis, Incremental pulse of master axis, Pulse of master axis (lead pulse), and Position of master axis. The following is the detail description for the four monitoring variables.

1. Accumulative pulse of master axis: monitoring variable code 059 (3Bh); the accumulative pulse number of the E-Cam master axis. Same as P5.086.
2. Incremental pulse of master axis: monitoring variable code 060 (3Ch); the incremental pulse number of the E-Cam master axis generated per 1 ms.
3. Pulse of master axis (lead pulse): monitoring variable code 061 (3Dh); when the clutch is engaged, the master axis disengagement pulse number (P5.089) decrements to 0 and then the clutch disengages; when the clutch is disengaged, the master axis lead pulse number (P5.087 or P5.092) decrements to 0 and then the clutch engages.
4. Position of master axis: monitoring variable code 062 (3Eh); the position of the E-Cam master axis.

**Pulse by-pass function**

When using the E-Cam and pulse by-pass functions, the servo drive can receive pulse signals and send these signals to the next servo axis, so multiple slave axes can refer to the same master axis signals. In addition, signals transmitted through the servo drives are not attenuated because the servo drive amplifies the signals to the strength they should have during output. For example, if the signal input is 4.5V, it becomes 5V when being output. Since there is electrical resistance in the wire, take the signal attenuation into account and use twisted-pair shielded wires. If the signals transmitted to the servo drive are attenuated to the level that the servo cannot identify, use a cable with thicker gauge or a shorter signal cable. If not considering the signal delay caused by cables, the delay time of each servo drive is 50 ns.

On the ASDA-A3 servo drives, the pulse output pins are OA, /OA, OB, and /OB of CN1 only; pulses can be input through CN1 or CN5 to the servo drive. Use P1.074.Y to set the output signal source for the servo drive. If selecting CN5 as the pulse input channel, as shown in Figure 7.3.1.2, then you must set P1.074.Y to 1 for each slave axis (servo drive) to have CN5 receive pulses. If selecting CN1 as the pulse input channel, as shown in Figure 7.3.1.3, then you must set P1.074.Y to 2 for each slave axis (servo drive) to have CN1 receive pulses.

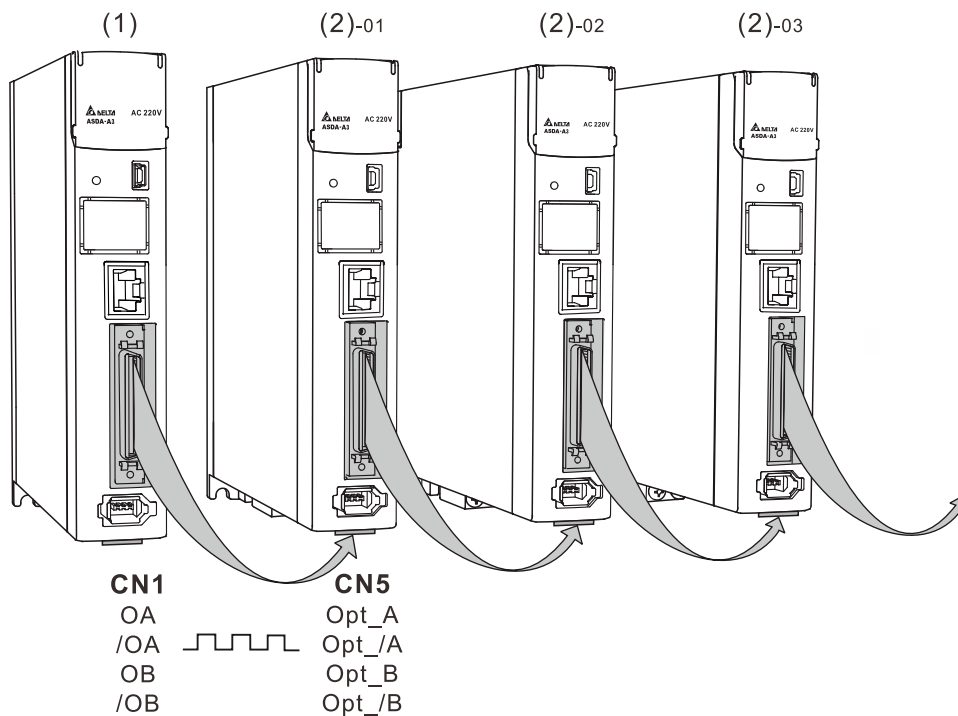

(1) Master axis; (2) Slave axes 1, 2, and 3.

Figure 7.3.1.2 Pulse by-pass function: CN1 output / CN5 input



7

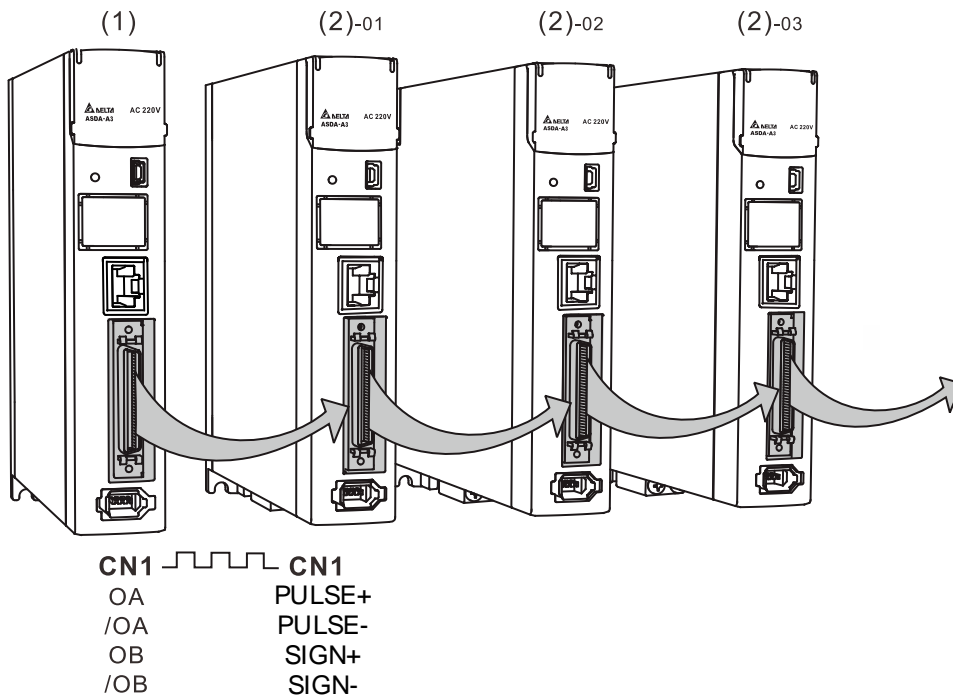

(1) Master axis; (2) Slave axes 1, 2, and 3.

Figure 7.3.1.3 Pulse by-pass function: CN1 output / CN1 input

### 7.3.2 Clutch engagement and disengagement

When the E-Cam function is enabled, the E-Cam clutch status determines whether the slave axis operates based on the signals sent from the master axis. While the clutch is engaged, the slave axis operates according to the received master axis pulses and the E-Cam curve; when the clutch is disengaged, the slave axis does not operate according to the E-Cam curve even if it receives the master axis pulses. The clutch engagement and disengagement timings are described as follows.

#### Clutch engagement condition

After the E-Cam function is enabled, the slave axis operates according to the master axis signals and E-Cam curve only when the clutch is engaged as shown in Figure 7.3.2.1. The timing for clutch engagement can be specified with P5.088.Z. The ASDA-A3 provides three condition options for clutch engagement timing:

1. Engage immediately (P5.088.Z = 0): the clutch engages immediately as soon as the E-Cam function is enabled. The slave axis operates according to the E-Cam curve and the master axis signals.
2. Engagement control with DI (P5.088.Z = 1): trigger DI.[0x36]CAM to have the clutch engaged. When this DI is triggered, the clutch remains engaged until the disengagement condition is met.
3. Engagement control with high-speed capturing (P5.088.Z = 2): when the master axis source is the Capture axis and the first position data is captured, input a signal from DI7 to have the clutch engaged immediately. Different from triggering DI.[0x36]CAM for clutch engagement, the high-speed capturing function only takes 5  $\mu$ s to have the clutch engaged using the DI7, making the system timing control more precise.

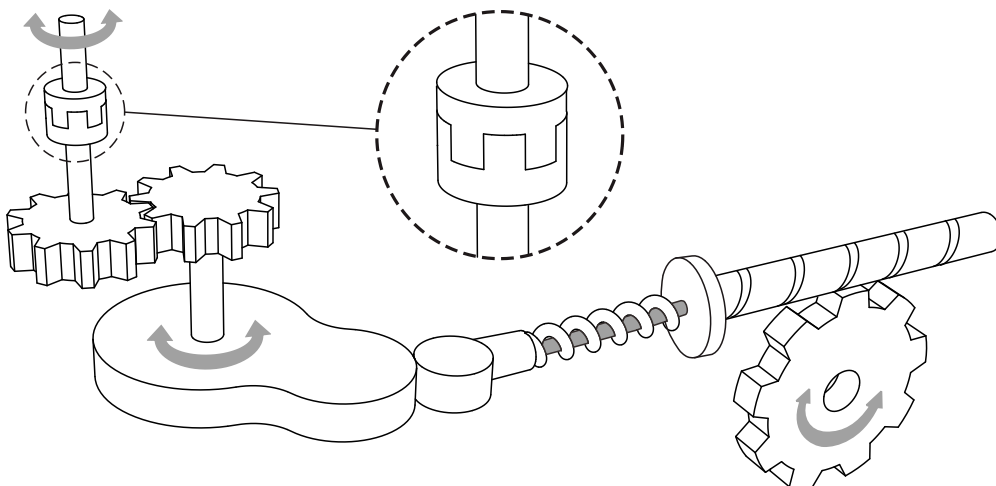

Figure 7.3.2.1 Clutch engagement

In addition, you can use P5.087 to set the initial lead pulse of the master axis before engagement. That is, once the engagement condition is met, the master axis needs to reach the set lead pulse number first and then the clutch is engaged, as shown in Figure 7.3.2.2.

# 7

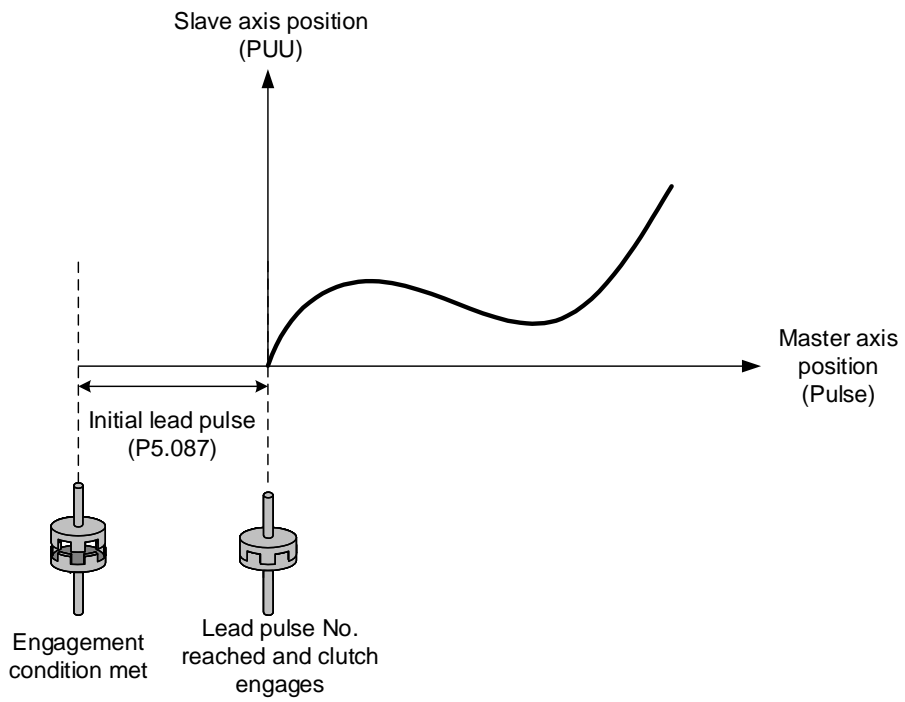

Figure 7.3.2.2 Initial lead pulse before clutch engagement

**Clutch disengagement condition**

When the E-Cam function is enabled and the clutch is engaged, the slave axis operates based on the E-Cam curve and master axis signals. When the slave axis completes the motion, you can directly disable the E-Cam function or disengage the clutch to stop the slave axis motion. While the clutch is disengaged, the slave remains stationary regardless of the master axis motion, as shown in Figure 7.3.2.3.

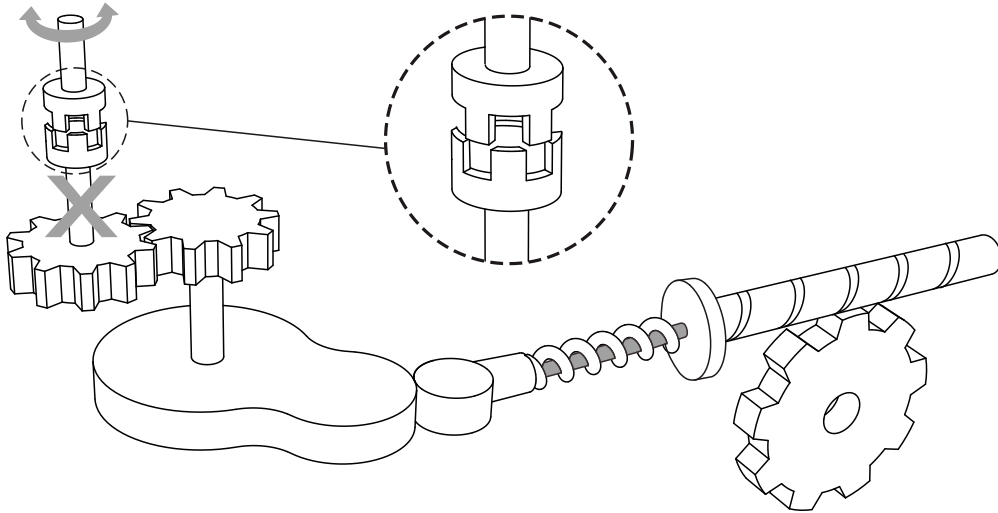

Figure 7.3.2.3 Clutch disengagement

7

You can use P5.088.U to select the disengagement condition depending on the applications. The ASDA-A3 provides five condition options for clutch disengagement timing.

1. Remain engaged (P5.088.U = 0): the clutch remains engaged unless the E-Cam function is disabled.
2. Disengagement control with DI (P5.088.U = 1): switch the DI.[0x36]CAM to off to have the clutch disengaged. When this DI remains off, the clutch remains disengaged and the E-Cam system is in stop state.
3. Immediate stop after disengagement (P5.088.U = 2): when the clutch is engaged and the pulse number of the master axis reaches the value set in P5.089, the clutch disengages, the slave axis stops immediately, and the E-Cam system is in stop state as shown in Figure 7.3.2.4. This function is suitable for applications that require the slave axis to accurately stop at the specified position.

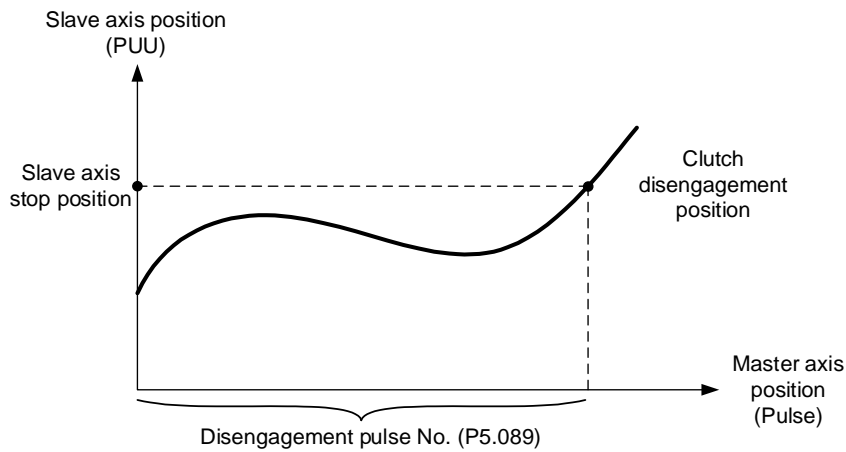

Figure 7.3.2.4 Disengagement timing: slave axis stops right after clutch disengagement

4. Decelerate to stop after disengagement (P5.088.U = 6): when the clutch is engaged and the pulse number of the master axis reaches the value set in P5.089, the clutch disengages, the slave axis decelerates to stop, and the E-Cam system is in stop state as shown in Figure 7.3.2.5. This function is suitable for applications that require the slave axis to slowly decelerate to stop.

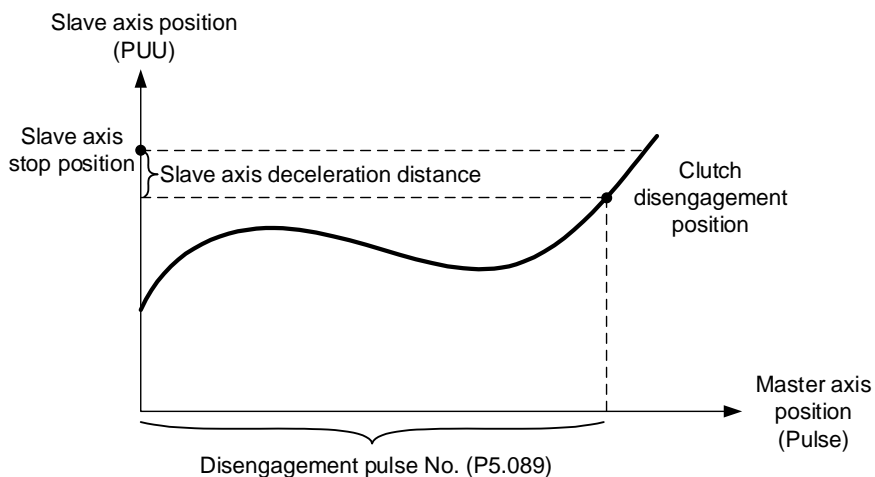

Figure 7.3.2.5 Disengagement timing: slave axis decelerates to stop after clutch disengagement

- Enter cyclic mode after disengagement (P5.088.U = 4): when the clutch is engaged and the pulse number of the master axis reaches the value set in P5.089, the clutch disengages and the master and slave axes enter the cyclic mode. Then, the E-Cam system goes into the pre-engage state and waits for the master axis pulse to reach the number set in P5.092. Next, the clutch re-engages and operation of the next cycle starts. See Figure 7.3.2.6.

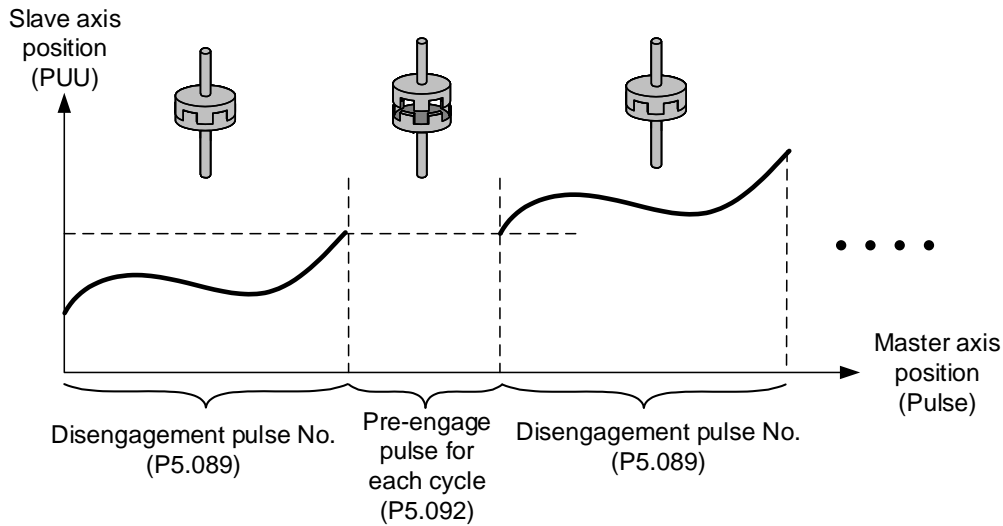

Figure 7.3.2.6 Disengagement timing: cyclic mode

Note that the “pre-engage pulse for each cycle” and the “initial lead pulse” are different. The “initial lead pulse” is valid only for the first engagement whereas the “pre-engage pulse for each cycle” is effective before each engagement cycle. You can see how these two work together in Figure 7.3.2.7.

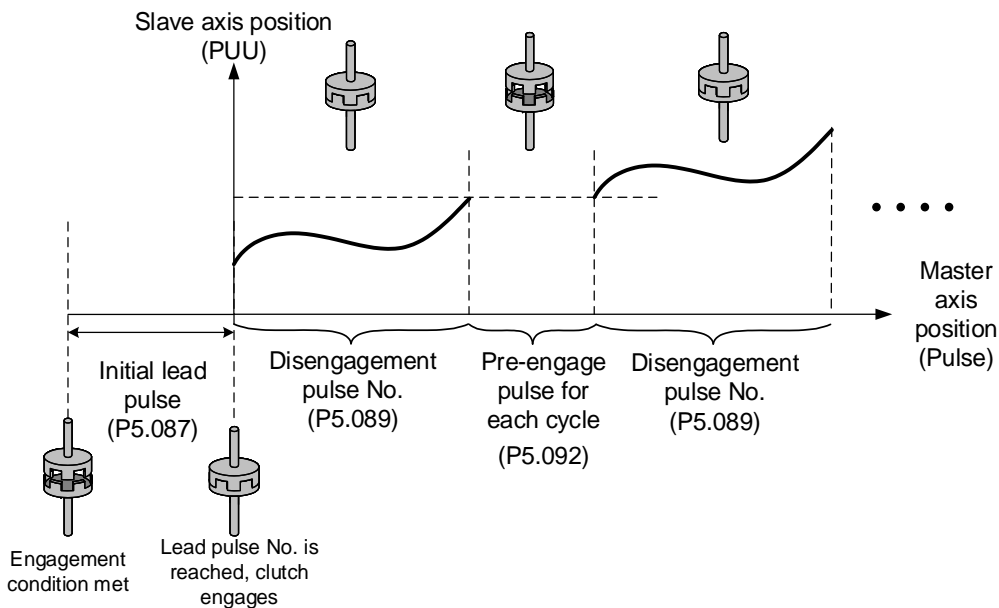

Figure 7.3.2.7 “Initial lead pulse” and “Pre-engage pulse for each cycle”

## 7

You can choose one of the three conditions for disengagement timing: “Immediate stop after disengagement”, “Decelerate to stop after disengagement”, or “Enter cyclic mode after disengagement” (P5.088.U = 2, 6, or 4). If you select the disengagement options such as “Disengagement control with DI”, “Immediate stop after disengagement”, or “Decelerate to stop after disengagement” (P5.088.U = 1, 2, or 6), you can activate the function for disabling the E-Cam after clutch disengagement (P5.088.U = 8). This is the same as setting P5.088.X to 0; however, you cannot set it individually; you need to use one of the three options (P5.088.U = 1, 2, or 6) when setting P5.088.U to 8. You can stop the slave axis by disengaging the clutch or disabling the E-Cam. Regardless of the current state of the E-Cam system (stop, engaged, or disabled), you need to enable the E-Cam function to operate it. When the clutch is disengaged, although the slave axis is stopped, the slave axis continues to monitor the signals sent from the master axis as the E-Cam system remains operating. Settings for clutch disengagement timing and disabling E-Cam function are as follows:

P5.088.U	Clutch disengagement condition	Status after disengaged
0	0: remains engaged.	-
1	1: disengages when DI.CAM (DI: 0x36) is off.	0: stop
2	2: disengages when master axis pulse number reaches the setting value of P5.089, and slave axis stops immediately.	0: stop
3	1 + 2: disengages when DI.CAM (DI: 0x36) is off or when master axis pulse number reaches the setting value of P5.089, and slave axis stops immediately.	0: stop
4	4: disengages when master axis pulse number reaches the setting value of P5.089 and enters the cyclic mode. When the pre-engaged pulse number for each cycle (P5.092) is reached, the clutch re-engages.	2: pre-engage
5	1 + 4: E-Cam enters the cyclic mode, but the clutch disengages when DI.CAM (DI: 0x36) is off.	0 or 2: pre-engage or stop
6	6: disengages when master axis pulse number reaches the setting value of P5.089, and slave axis decelerates to stop.	0: stop
7	1 + 6: disengages when DI.CAM (DI: 0x36) is off or when master axis pulse number reaches the setting value of P5.089, and slave axis decelerates to stop.	0: stop
8	8: set other disengagement conditions first, and the E-Cam function is disabled after the clutch disengages.	-
9	1 + 8: disengages when DI.CAM (DI: 0x36) is off and the E-Cam function is disabled.	0: stop and disable E-Cam.
A	2 + 8: disengages when master axis pulse number reaches the setting value of P5.089, slave axis stops immediately, and the E-Cam function is disabled.	0: stop and disable E-Cam
B	1 + 2 + 8: disengages when DI.CAM (DI: 0x36) is off or when master axis pulse number reaches the setting value of P5.089, slave axis stops immediately, and the E-Cam function is disabled.	0: stop and disable E-Cam
C	4 + 8 (special function): eases the speed vibration when the clutch returns to the pre-engaged condition. This is generally applied when the pre-engaged pulse number for each cycle (P5.092) is 0 and the pulse number of disengaging time equals master gear ratio (P5.089 = P5.084).	2: pre-engage
D	1 + 4 + 8: disengages when DI.CAM (DI: 0x36) is off, otherwise operates according to the condition of P5.088.U = C.	0 or 2: stop and disable E-Cam or pre-engage

P5.088.U	Clutch disengagement condition	Status after disengaged
E	6 + 8: disengages when master axis pulse number reaches the setting value of P5.089, slave axis decelerates to stop, and the E-Cam function is disabled.	0: stop and disable E-Cam.
F	1 + 6 + 8: disengages when DI.CAM (DI: 0x36) is off or when master axis pulse number reaches the setting value of P5.089, slave axis decelerates to stop, and the E-Cam function is disabled.	0: stop and disable E-Cam.

Note: for the system status after disengagement, refer to the following sections.

You can choose one of the three disengagement conditions for the PR path after the clutch disengagement, which are “Immediate stop after disengagement”, “Decelerate to stop after disengagement”, and “Enter cyclic mode after disengagement” (P5.088.U = 2, 6, or 4). Write the PR number in hexadecimal to P5.088.BA. If this value is 0, it means no PR path is executed after the **disengagement**. In addition, if you use the setting “Enter cyclic mode after disengagement (P5.088.U = 4)” and specify the following PR path, as the E-Cam function does not have an interruption setting, the slave axis carries on to the next cycle until the motion set in the PR path is complete.



### E-Cam system status

The E-Cam system has three states, Stop, Engage, and Pre-engage. When the E-Cam function is enabled, you can use P5.088.D to promptly monitor the system's current status. The following section explains each state, as shown in Figure 7.3.2.8.

1. Stop state (P5.088.D = 0): the clutch is disengaged and the system continues to check the engagement condition (P5.088.Z). If the engagement condition is met and the initial lead pulse (P5.087) is not set, the clutch engages. If you have set the initial lead pulse, the system enters the Pre-engage state. When the E-Cam function is disabled, the system is also in the stop state.
2. Engage state (P5.088.D = 1): the clutch is engaged and the system continues to check the disengagement condition (P5.088.U). If one of the three disengagement conditions, "Disengagement control with DI", "Immediate stop after disengagement, or "Decelerate to stop after disengagement" (P5.088.U = 1, 2, or 6) is met, the system is stopped. If the condition "Enter cyclic mode after disengagement (P5.088.U = 4)" is met, the system enters the Pre-engage state.
3. Pre-engage state (P5.088.D = 2): the clutch is disengaged. If pulses from the master axis reach the initial lead pulse number or the pre-engaged pulse number for each cycle, the clutch engages and the system enters the Engage state.

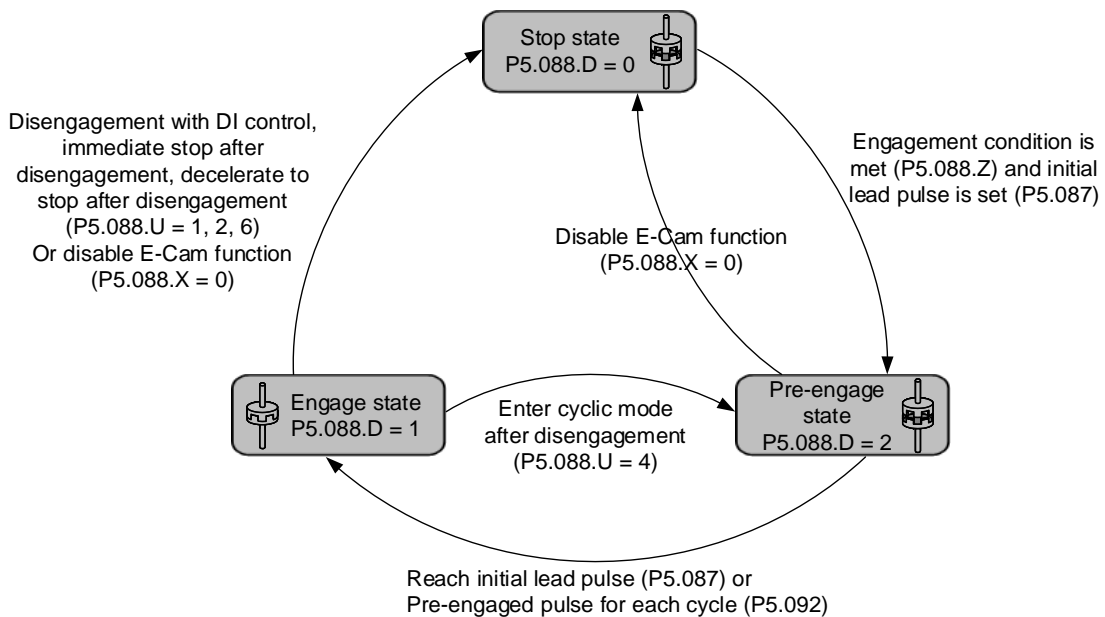
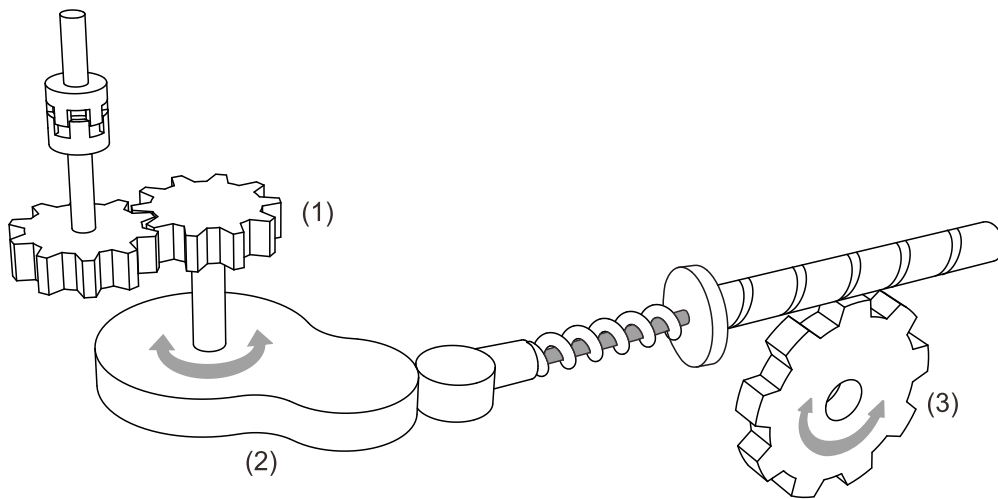

Figure 7.3.2.8 E-Cam system status

### 7.3.3 E-Cam gears and curve scaling

In the E-Cam system, two sets of E-Gears can determine the E-Cam motion, which are E-Gears of the master axis and E-Gears of the slave axis. The E-Gears of the slave axis is the same as that of the whole servo system. Their E-Gear settings are both determined by P1.044 and P1.045. Changing this E-Gear ratio will change the E-Cam motion and motion commands in PT and PR modes as well. Therefore, if you need to change the E-Cam curve scaling, changing P1.044 and P1.045 is not suggested.

The E-Gear of the master axis is only for the E-Cam system and can change the pulse command resolution of the master axis. The setting parameters are P5.083 and P5.084. When the slave axis receives the pulse number defined by P5.084 from the master axis, E-Cam rotates the number of cycles defined by P5.083 (one cycle of E-Cam = rotate from 0° to 360°).



- (1) E-Gear of master axis: P5.083 and P5.084 for command pulse resolution
- (2) E-Gear curve: P5.019 for scaling
- (3) E-Gear of slave axis: P1.044 and P1.045 for output signal resolution

Figure 7.3.3.1 E-Cam gear ratio

7

The following example illustrates how the command resolution is adjusted: assume that the original master axis pulse number for one cycle is 10000 pulses as shown in Figure 7.3.3.2. If this master axis E-Gear ratio becomes larger (P5.084 increases or P5.083 decreases), then the master axis pulse unit corresponds to a narrower E-Cam phase, making the master axis pulse command resolution higher. When the master axis E-Gear ratio becomes smaller (P5.084 decreases or P5.083 increases), the master axis pulse unit corresponds to a wider E-Cam phase, making the master axis pulse command resolution lower. In common applications, P5.083 is set to 1 and P5.084 is for specifying the required master axis pulse number for the E-Cam to operate one cycle. If the required master axis pulse number has decimal places, you can adjust the value of P5.083. For example, when the required master axis pulse for operating one cycle is 517.5, you can set P5.083 to 2 and P5.084 to 1035.

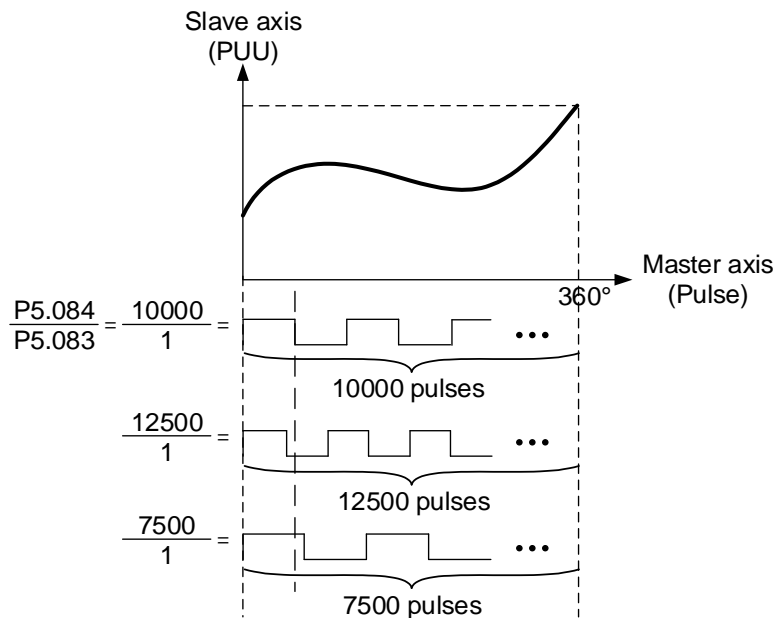

Figure 7.3.3.2 E-Gear ratio for E-Cam

To change the slave axis motion path proportionally in E-Cam applications, it is suggested that you use P5.019 to scale the E-Cam curve. This parameter is only effective to the E-Cam system and does not affect other motions in the servo system. As shown in Figure 7.3.3.3, if P5.019 = 2, the output curve of the slave axis is two times of the original. If P5.019 = 0.5, the output curve of the slave axis is 0.5 times of the original. If P5.019 = -1, the positive and negative outputs of the slave axis are reversed.

P5.088.X Bit 2 can specify the effective timing for the E-Cam curve scaling with the options of taking effect immediately and after clutch re-engagement. For example, after adjusting the cutting length in flying shear applications, you can use this parameter to determine when to make the modified E-Cam curve scaling take effect. If the clutch is set to remain engaged and modifying the cutting length is required, set P5.088.X Bit 2 to 1 (modified E-Cam curve scaling

is effective immediately). Do not modify P5.088 during cutting, or the machine might be damaged.

If you set P5.088.X Bit 2 to 0 to have the modified E-Cam curve scaling take effect upon the next engagement, then the cutting length changes upon the next clutch engagement. For details about flying shear applications, refer to Section 7.3.8.

7

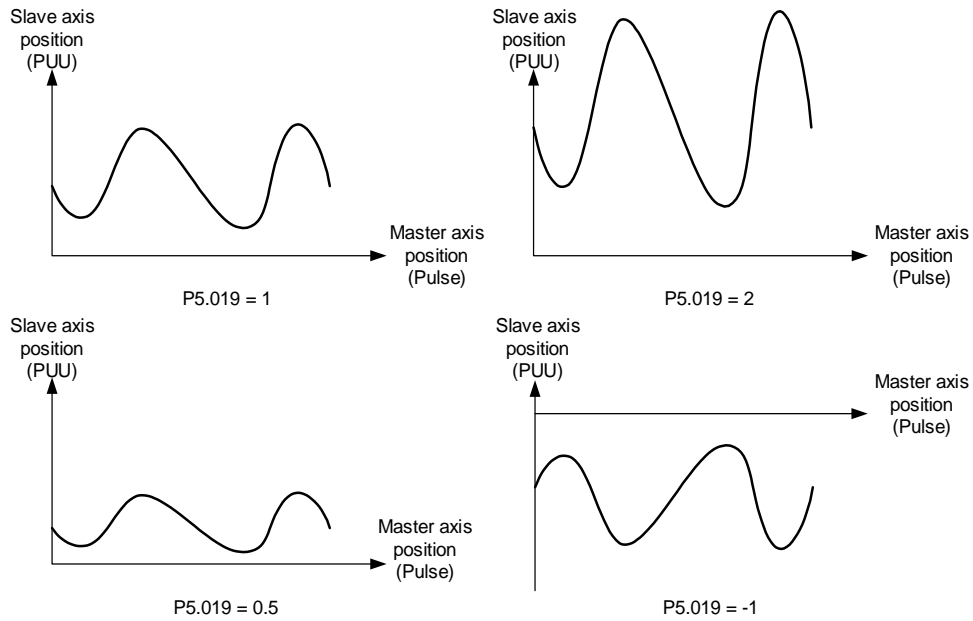

Figure 7.3.3.3 E-Cam curve scaling

7

7.3.4 E-Cam curve

E-Cam curve is created by the mathematic function based on positions of the master and slave axes. There are various ways to create the table. You can use mathematic tools (software) or use the tabulation interface for industry-specific applications provided in ASDA-Soft. Regardless of the tabulation methods, the software converts the mathematic function into position data and stores them in the data array. One E-Cam curve can have up to 721 sets of data (divided 720 times). It means the highest resolution is 0.5 degrees. As long as the total point number is within the data array's maximum 800, the array can store multiple E-Cam curves. The slave axis curve between two data points will be interpolated with a cubic curve to smooth the motion at each point.

See Figure 7.3.4.1 for example. If using E-Cams to replace mechanical cams, divide the mechanical cam into several segments. The more the segments, the higher the precision. In this example, the cam is divided into 8 segments, and each interval is 45 degrees (this is for reference only; you need to delicately segment the cam in the actual application, or the path will be distorted). Then, enter the distance between the cam shaft and the points (1 - 8) on the cam edge to the data array. The start point 0 degree and the last point 360 degrees are identical but you must enter both of the two points to the data array so the the E-Cam can completely go around the mechanical cam for one cycle. Therefore, you need to enter 9 sets of data to complete the E-Cam curve table.

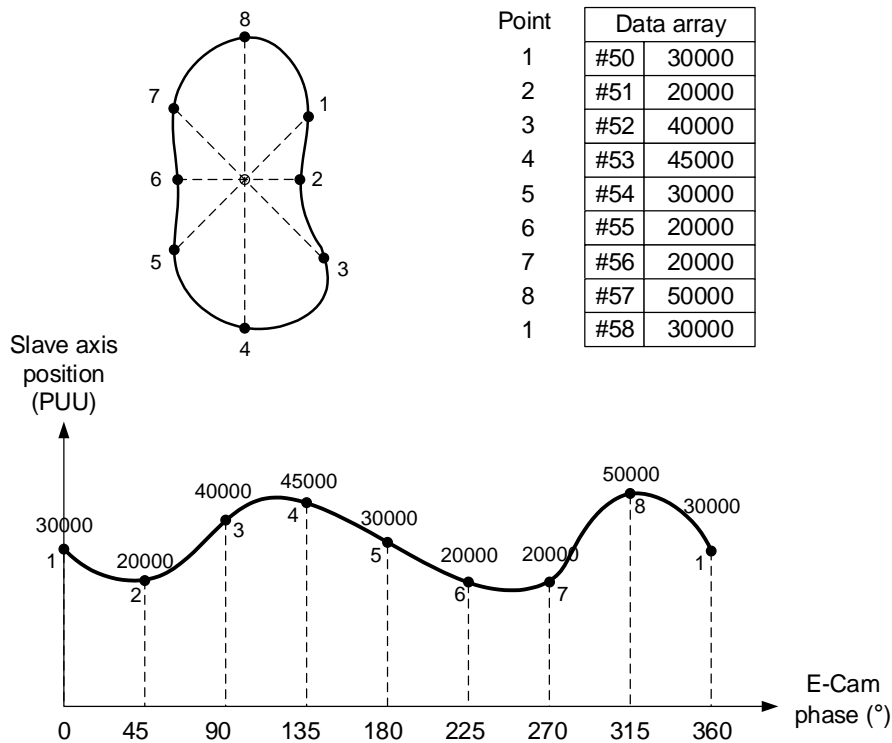

Figure 7.3.4.1 Example of creating E-Cam curve table

You can use ASDA-Soft to create the E-Cam curve. Click **E-CAM** in the software function list and the E-CAM Editor appears, as shown in Figure 7.3.4.2.

In the first page of the editing window, select the method to create the E-Cam curve table. There are seven options, [Manual], [Speed Fitting], [Rotary Shear - W/O Sync. Zone], [Rotary Shear - Fixed Sync. Zone], [Rotary Shear - Adjustable Sync. Zone], [Cubic Curve], and [Rotary Shear - Printing Machine].

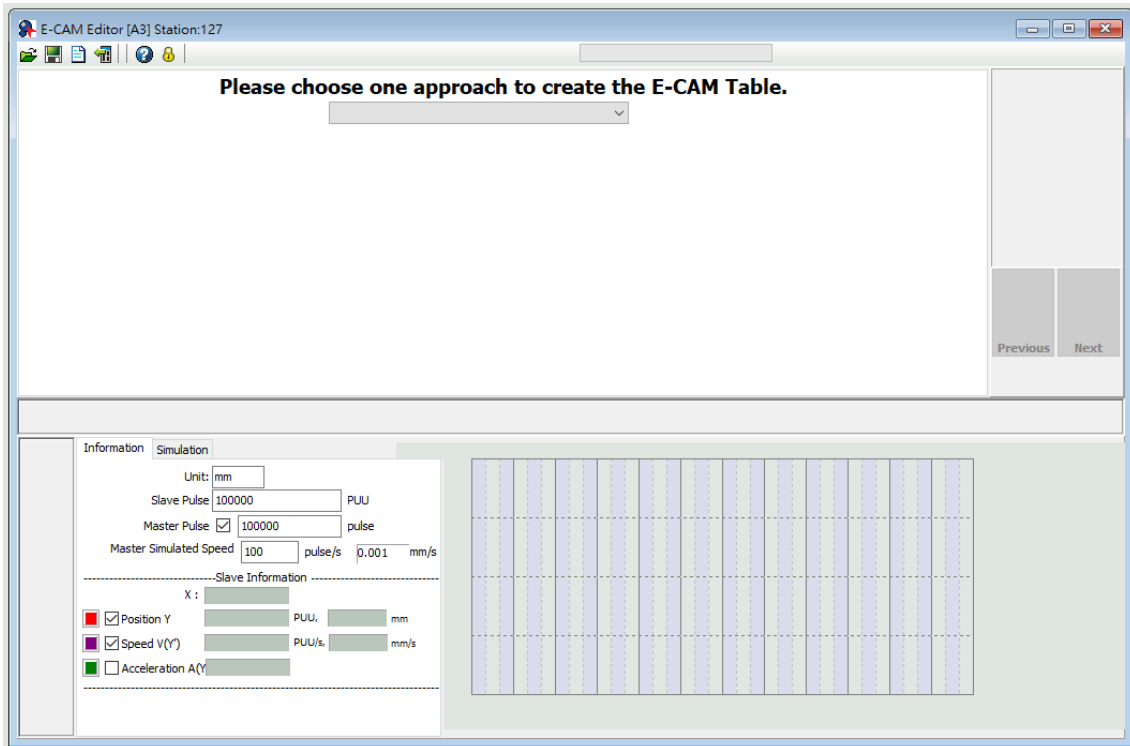

Figure 7.3.4.2 ASDA-Soft E-Cam setting interface

## Manual

When you use other software to create the table, the software presents the final results with position data and then imports these data to the table to complete the E-Cam curve. As the example shown in Figure 7.3.4.1, the mechanical cams can be replaced by E-Cams. It creates the E-Cam curve by using the angles of the mechanical cams corresponding to the distances between the cam shaft and edge, which is to establish the correlation of the angles and slave axis positions. The setting interface for manually creating E-Cam tables in ASDA-Soft is shown in Figure 7.3.4.3. The following illustrates the steps to manually create the table:

1. Set the E-Cam segment number: an E-Cam can be divided into up to 720 segments (721 points). For a 360-degree cycle, every 0.5 degrees corresponds to a slave axis position. The more the points, the higher the resolution and the more delicate the curve. Appropriately allocate the resources for the curve resolution and data array to set the E-Cam segment number.

7

2. Create curve table: after setting the E-Cam segment number, click **Create Table**, and the software equally segments the 360-degree E-Cam and automatically fills in the angle data to the table. When you set n points for the E-Cam segment number, the table has n+1 columns.
3. Fill in the slave axis positions: fill in the corresponding position in PUU for each segment. Click **Draw**. The software automatically generates a simulated E-Cam curve and cam position, speed, and acceleration curve. When manually creating the table, pay more attention to the speed continuation of the slave axis to avoid machine vibration or motor overload caused by speed discontinuation.
4. Download E-Cam curve: once the E-Cam curve is confirmed, click **Download Table** to write the E-Cam curve to the data array. If you click **Write Table Data to EEPROM**, the data array is written to EEPROM and is non-volatile.

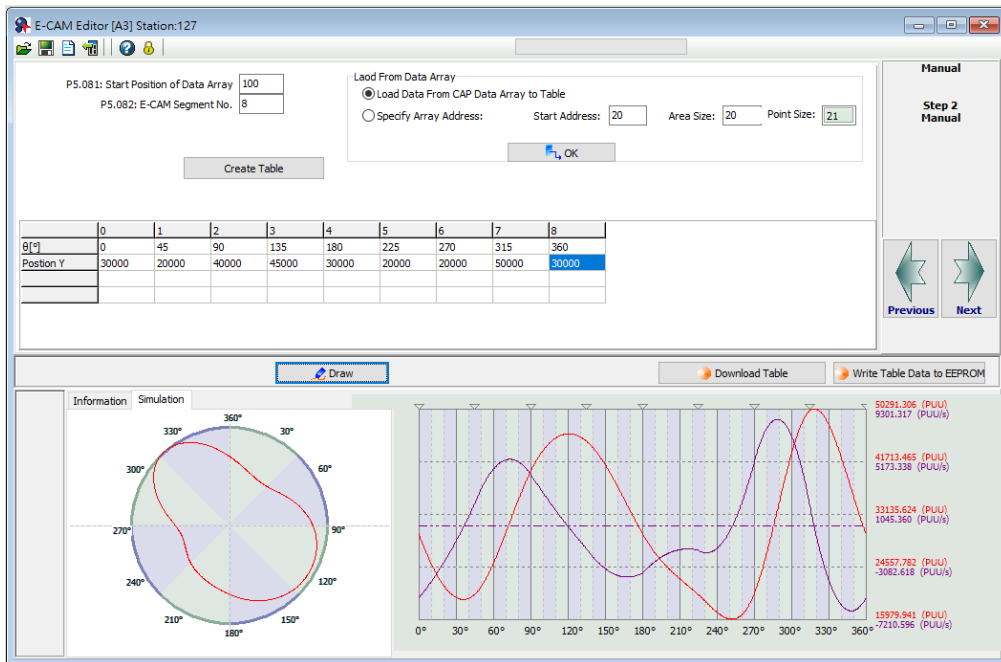

Figure 7.3.4.3 ASDA-Soft Manual setting interface for creating E-Cam table

When using a third-party software (such as Excel) to create the table, save all position data as a text file (.txt) and use the Space, Tab, Enter keys, vertical bar "|", or a comma "," to separate the position data of each point.

If you start the E-CAM Editor in ASDA-Soft and choose to manually create the table, specify the E-Cam segment number (P5.082), and click **Create Table**, and then the table displays the E-Cam phase corresponding to the E-Cam segments. Right-click the table, select **Import points**, and then click **Browse** after the window for importing point data appears. Open the text file that has been saved, and select the separator you use in the saved file for **Separate symbol**. Then, click **OK** to complete loading the text file. Next, click **Draw** to have the software generate the E-Cam curve based on the E-Cam positions. You can also export the position data as a text file.

Right-click the table, and select **Batch change the values**, including increment, decrement, addition (+), deduction (-), multiplication (\*), division (/), copy, and exchange functions for users to change the E-Cam curve quickly. There are also functions for inserting and deleting single position data on the right-click menu. The setting interface for creating E-Cam tables with a third-party software in ASDA-Soft is shown in Figure 7.3.4.4.

7

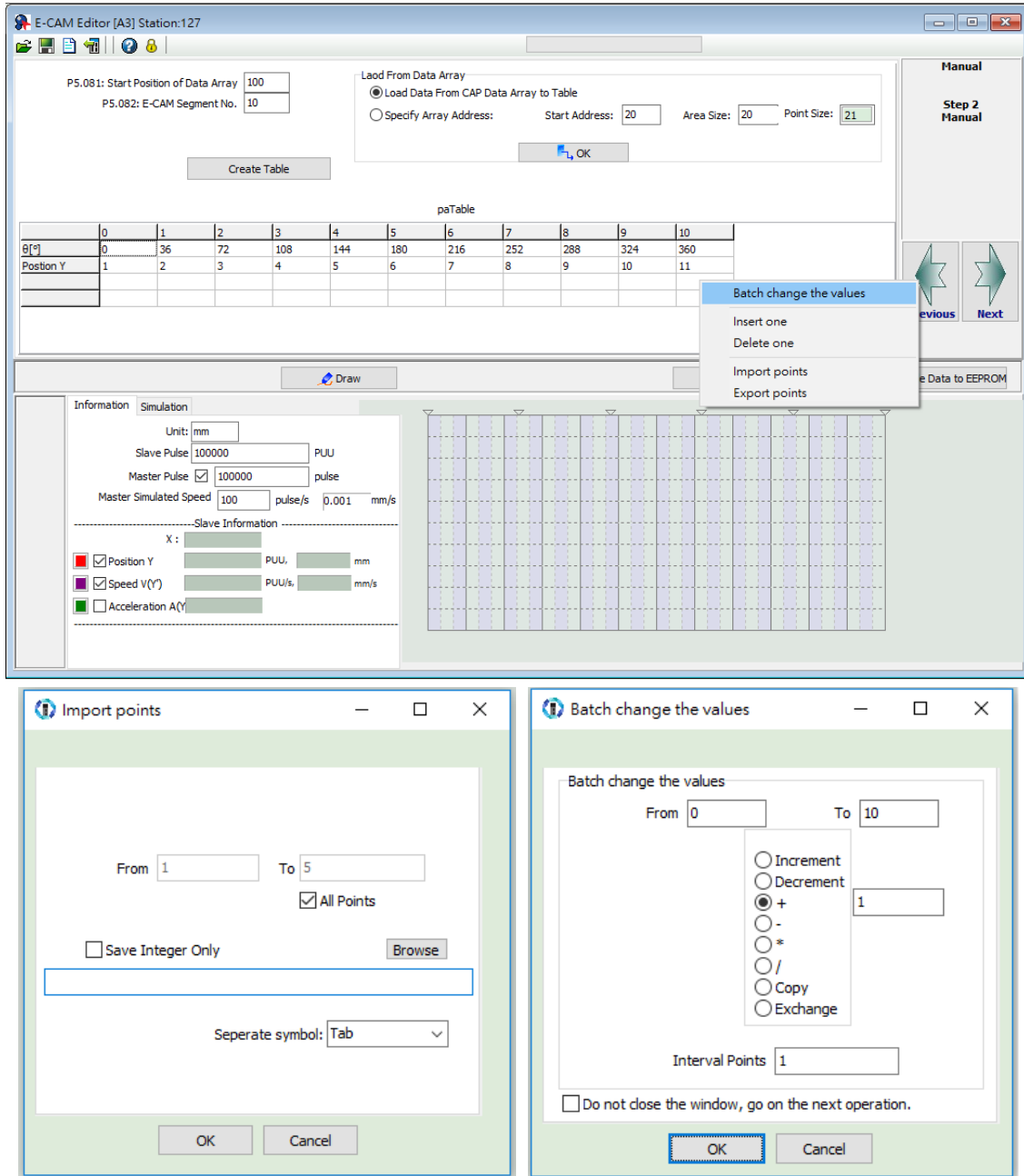

Figure 7.3.4.4 Use third-party software to create E-Cam curves



## Speed Fitting

When the application requires the motions of both the master and slave axes to keep the same speed or have the same correspondence relations, you can use the speed fitting method to create the E-Cam curve. With this method, the E-Cam cycle is divided into five zones, which are the waiting, acceleration, synchronous speed, deceleration, and stop zones as shown in Figure 7.3.4.5. You can adjust the proportion of each zone as needed.

This E-Cam curve is designed based on the positions. It plans the corresponding speed of the master and slave axes based on the relationship between the position change and speed within a given time. The setting interface for creating E-Cam curves with the speed fitting method in ASDA-Soft is shown in Figure 7.3.4.6. Steps to create the table with the speed fitting method are as follows:

1. Plan the E-Cam curve: determine the proportions of the waiting, acceleration, synchronous speed, deceleration, and stop zones within an E-Cam cycle.
2. Set the total moving distance (lead): set the total moving distance of the slave axis within one cycle in the unit of PUU.
3. Set the S-curve: set smoothness at the transition points of the position curve. The higher the value, the smoother the motor acceleration or deceleration, and the longer the operation cycle. The S-curve setting value is usually the same or smaller than the stop zone point number.
4. Download E-Cam curve: once the E-Cam curve is confirmed, click **Download Table** to write the E-Cam curve to the data array. If you click **Write Table Data to EEPROM**, the data array is written to EEPROM and is non-volatile.

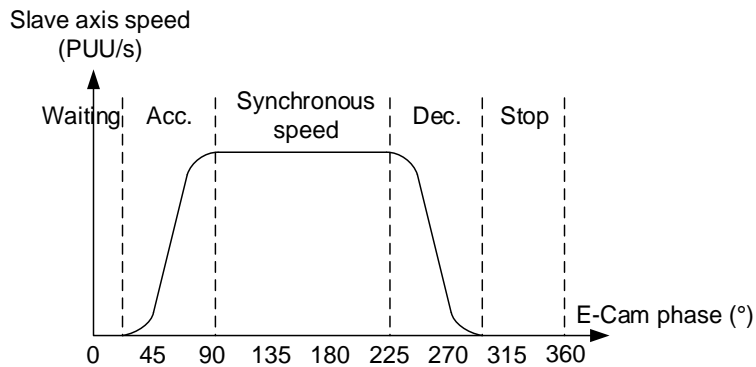

Figure 7.3.4.5 Speed fitting zone definition

The screenshot shows the E-CAM Editor [A3] Station:127 interface. It is divided into several sections:

- Speed Section:** Contains parameters for various zones:
  - P5.081: Start Position of Data Array: 100
  - P5.082: E-Cam Segment No.: 72
  - IDL1: waiting zone: 8 % => 6
  - ACC: acceleration zone: 13 % => 9
  - CONST: synchronous speed zone: 46 % => 33
  - DEC: deceleration zone: 13 % => 9
  - IDLE2: stop zone: 20 % => 15
  - Distance: 100000 PUU
  - S Curve No.: 10
- Illustration Table:** A table with columns for 4, 5, 6, 7, 8, 9, 10, 11. The first row is labeled 'θ [°]' and the second row is 'Position Y'. Values are:
 

θ [°]	4	5	6	7	8	9	10	11
Position Y	20	25	30	35	40	45	50	55
- Parameters:**
  - P5.083: Master gear ratio setting - Cycle: 1
  - P5.084: Pulse number of master axis: P: 3600 (Pulse number of master axis P corresponds to E-CAM table M cycle)
- Speed Fitting:** Step 2 Speed Fitting. Includes 'Previous' and 'Next' navigation buttons.
- Simulation:**
  - Information:** A circular diagram showing a 360-degree rotation with markers every 30 degrees.
  - Graph:** A plot of speed (PUU/s) vs. position (degrees). The speed curve starts at 0, rises to a peak of 10000.211 PUU/s, stays constant, and then falls back to 0. The position axis ranges from 0° to 360°.

7

Figure 7.3.4.6 ASDA-Soft Speed Fitting setting interface for creating E-Cam table

## 7

**Cubic Curve**

If the master and slave axes operate only based on the corresponding positions, such as the point-to-point relation, you can use the cubic curve method to create an E-Cam curve. If using the cubic curve method to create the table, simply enter the E-Cam phase and the corresponding slave axis positions to have the tabulation tool automatically connect the points and optimize the curve. In some applications, you might need a point-to-point cam motion trajectory such as a constant line or curve, and then you can use the cubic curve method to modify the curve, and set the start angle N1 (the angle departing from the start point) and the end angle N2 (the angle arriving at the target point) as needed, as shown in Figure 7.3.4.7.

There are three types of curves for creating the table:

1. Constant speed: a constant-speed linear trajectory connecting two sets of cam point data; the start and end angles are unadjustable.
2. Uniform acceleration: a uniform incremental or decremental curve in single direction. Only the start angle is adjustable.
3. Cubic curve: the start and end angles are both adjustable. Changing the angles also changes the speed when departing from the start point and arriving at the target point. Note that improper angle setting leads to drastic speed change which causes machine vibration.

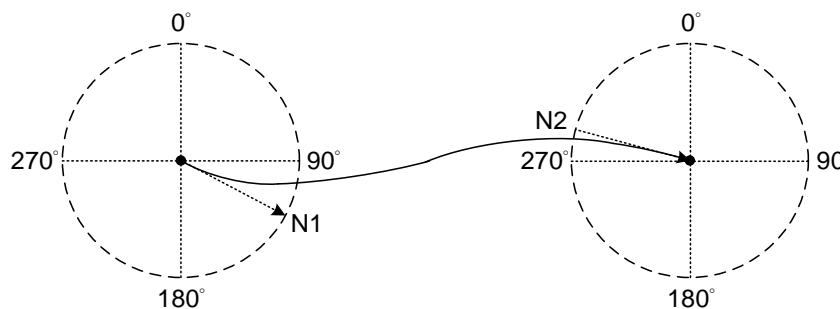

Figure 7.3.4.7 Start angle and end angle

Figure 7.3.4.8 is the cubic curve setting interface for creating E-Cam tables in ASDA-Soft. The steps to create the table with the cubic curve method are as follows:

1. Set the E-Cam curve: set the E-Cam phase, slave axis position, curve type, start and end angles in Cubic Data. You can drag the transition points in the cubic curve simulation to change the corresponding data of each point. When you drag, insert, or delete the transition points, the corresponding cubic data contents are promptly changed. However, if you directly enter or select the desired content in the cubic data, you must click **Create Cubic Curve** to change the cubic curve simulation.
2. E-Cam table setting: when completing the transition point setting, set the sampling angle and click **Convert to E-Cam table**, so the software will fill in the sampling data to the E-Cam table. The more the sampling points, the more accurate the cam shapes. If the setting value for the slave axis is too small, vibration might occur because the decimal



7

### 7.3.5 E-Cam curve and PR command overlapping

When the E-Cam curve is operating, if you trigger a PR path of incremental position command, the E-Cam command is overlapped with the PR command. As shown in the upper part of Figure 7.3.5.1, the moving direction of the slave axis is the same as that set in the incremental position command. When the slave axis is moving at 300 rpm and you trigger an incremental position command with the target speed of 200 rpm in the same direction, the slave axis overlaps the PR incremental position command with the E-Cam command and completes the 5000 PUU incremental position command at the target speed of 500 rpm. As shown in the lower part of Figure 7.3.5.1, the moving direction of the slave axis is opposite to that set in the incremental position command. When the slave axis is moving at 300 rpm and you trigger an incremental position command with the target speed of 200 rpm in the reverse direction, the slave axis executes the E-Cam command at the target speed of 100 rpm. Then, it resumes the original speed after the incremental position command of -5000 PUU is executed completely.

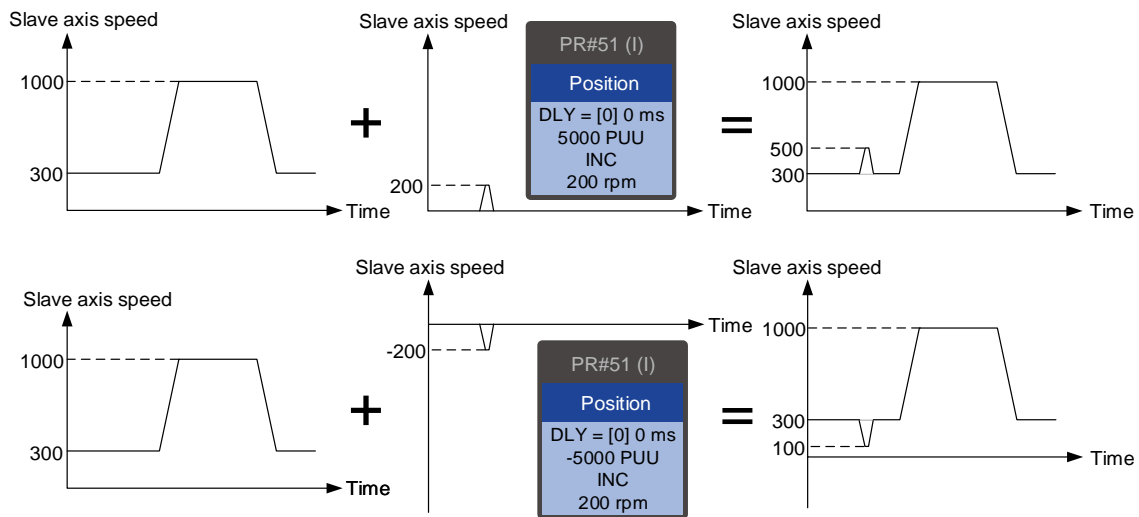

Figure 7.3.5.1 Overlapping of E-Cam command and PR incremental position command

To change the E-Cam phase when E-Cam is operating, use the PR incremental position command. Both the phase alignment function and macro for the rotary shear, which align the E-Cam phase, are completed by this command overlapping method. For more about this function, refer to Sections 7.3.7 and 7.3.9.

Take the triple-axis synchronous printing machine shown in Figure 7.3.5.2 for example. The material feeder is the master axis sending pulse signals to have the three slave axes operate based on the same E-Cam curve. Generally, the E-Cam phases of the three axes must be consistent. If inconsistent, use the command overlapping function to correct the E-Cam phase. To shift the phase in the forward direction, set the forward incremental command. To shift the phase in the reverse direction, set the reverse incremental command.

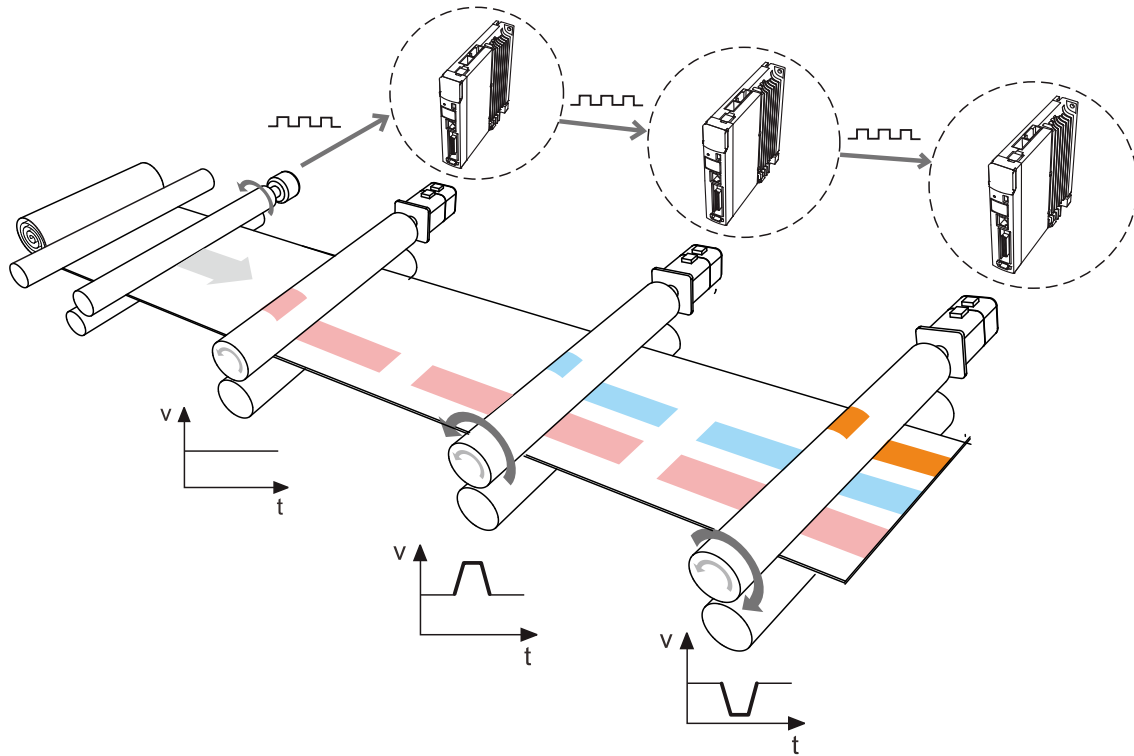

Figure 7.3.5.2 E-Cam phase alignment function

### 7.3.6 Troubleshooting for E-Cam

If the E-Cam cannot operate normally, follow these steps to troubleshoot:

1. Servo drive control mode: make sure the control mode is PR mode and the system is in the Servo On state.
2. Pulse source of master axis: check the setting of P5.088.Y for the source of the master axis. Use P5.086 or monitoring variable 059 to read the pulse count of the master axis. If selecting CN1 as the input connector, use P5.018 to monitor the pulse count; if selecting CN5 as the input connector, use P5.017 to monitor the pulse count.
3. E-Cam curve: read the E-Cam curve data in the data array. Make sure the E-Cam curve is correct and check the settings for P5.081 (E-Cam: start address for data array) and P5.082 (E-Cam: segment number (N)).
4. E-Cam gear ratio and scaling of E-Cam curve: check the master axis E-Gear ratio (P5.084 / 5.083) and the slave axis E-Gear ratio (P1.044 / P1.045). Check the E-Cam curve scaling (P5.019). If the proportion is set too small, the motor operation is too subtle to be monitored even when E-Cam is operating. In this case, use the scope in the ASDA-Soft to see if the motor is slightly rotating.
5. Clutch status: read P5.088.D to obtain the current status of the clutch.  
If P5.088.D = 0, it means the clutch is disengaged. Check the engagement setting (P5.088.Z).  
If P5.088.D = 1, it means the clutch is engaged and the slave axis operates based on the pulses from the master axis. If the disengagement condition is determined by the DI (P5.088.U = 1), check the timing for triggering the DI to on and off. If the disengagement condition is set to "Immediate stop after disengagement" (P5.088.U = 2) or "Decelerate to stop after disengagement" (P5.088.U = 6), check the pulse number of disengaging time (P5.089).

6. If P5.088.D = 2, it means the clutch is in the pre-engage status. Check the setting for the initial lead pulse before engaged (P5.087). The clutch engages only when receiving the set number of pulses in the forward direction from the master axis. If the received pulses are in the reverse direction, modify the setting according to the master axis pulse source:
- Master axis pulse source: change the encoder output polarity for the servo drive (P1.003).
  - Master axis pulse input from CN5: change the auxiliary encoder feedback direction (P1.074.Z).
  - Master axis pulse input from CN1: directly modify the wirings by exchanging the wirings for the A and B phase signals.

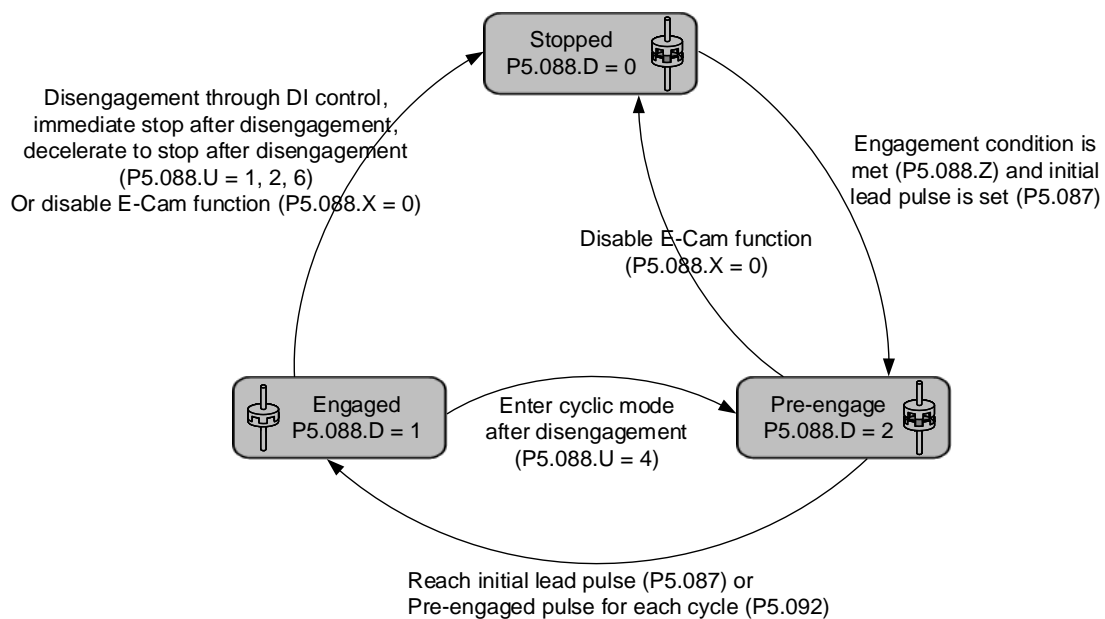



### 7.3.7 Rotary Shear

7

The rotary shear system is a system that combines the material feeder and cutter; the cutter cuts simultaneously when materials are fed as shown in Figure 7.3.7.1. Similar systems are widely used in different applications, such as cutting machines, printing machines, and packing machines. In this example, the material feeder is the master axis in the E-Cam system. When the master axis operates, it simultaneously sends pulse commands to the slave axis (cutter).

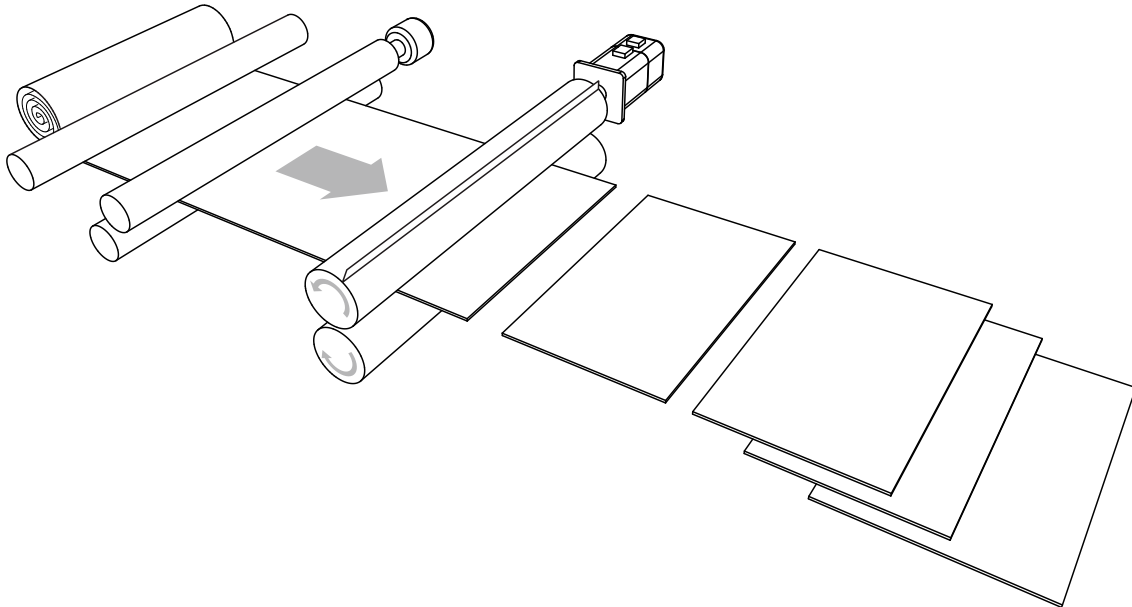
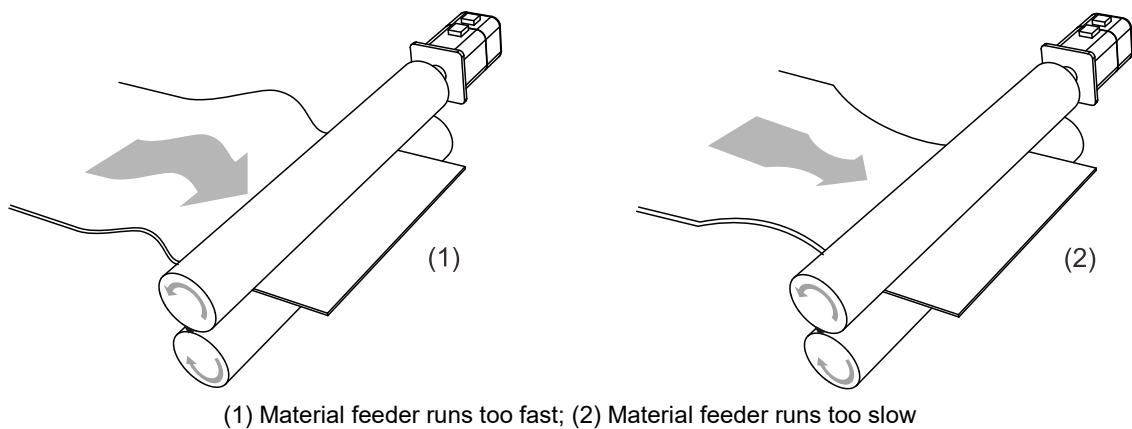

Figure 7.3.7.1 Rotary shear system - cutting machine

Apart from the requirement for calculating the correct cutting length, the operation speeds of both the material feeder and cutter have to be the same during cutting. This stage in the E-Cam curve is called the synchronous speed zone. During cutting, if the material feeder runs too fast, the material might be crushed or piled in front of the cutters, as shown in Figure 7.3.7.2 (1). If the feeder runs too slow, the cutter might over-stretch the material, causing the distortion of the material as shown in Figure 7.3.7.2 (2).



(1) Material feeder runs too fast; (2) Material feeder runs too slow

Figure 7.3.7.2 Inconsistent speed in synchronous speed zone for cutting machine operation

**E-Cam curve**

In the E-Cam curve for the rotary shear system, apart from the requirement that the cutter cuts at the right position, it is important that the master axis and slave axis run at the same speed, which means the relative speed is zero, so the the materials are not over-stretched during cutting. In terms of cutters, wider cutters require larger synchronous speed zone (as shown in Figure 7.3.7.3). The proportion of this zone is determined by the cutting length instead of the cutter width, as shown in Figure 7.3.7.4.

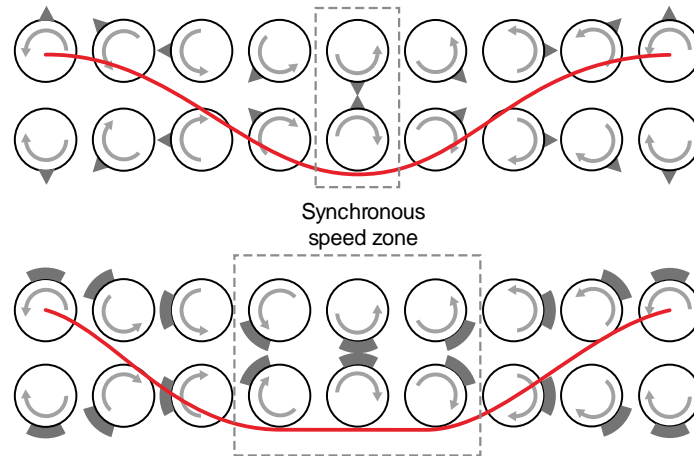

Figure 7.3.7.3 Cutter type and synchronous speed zone

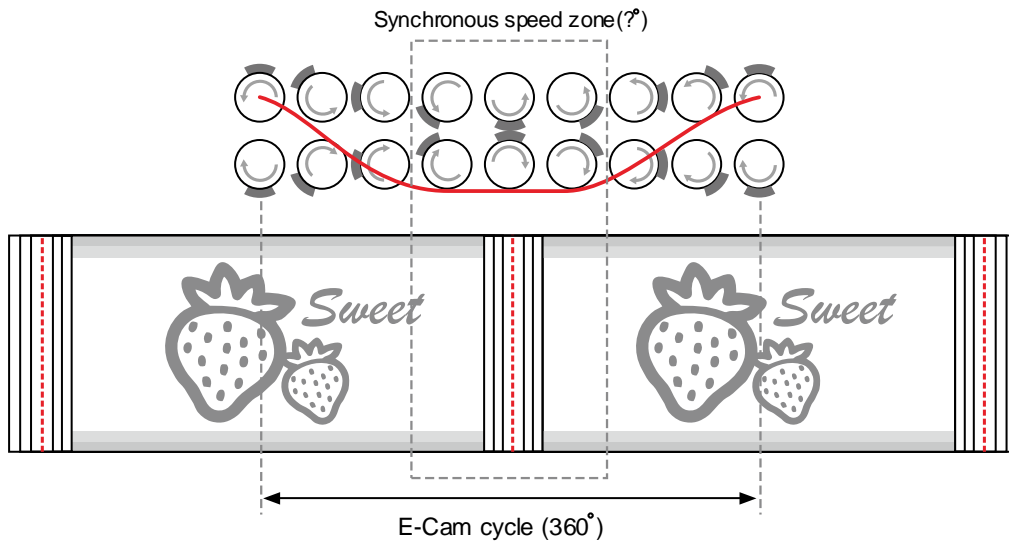
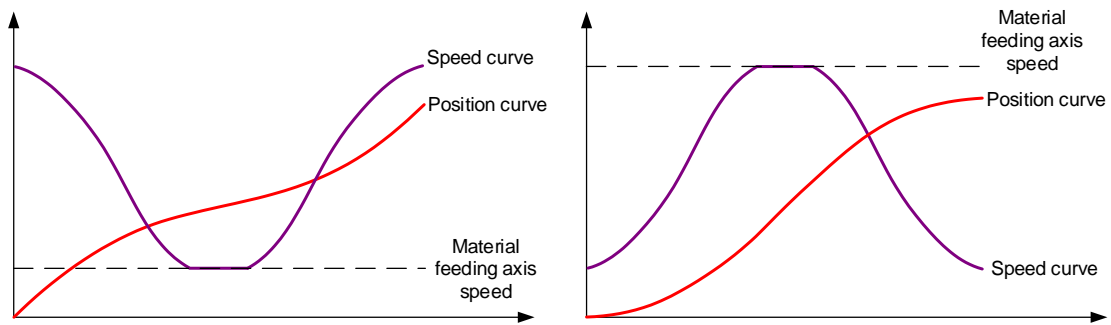

Figure 7.3.7.4 Definition of synchronous speed zone

7

For E-Cam curves used in the rotary shear applications, apart from the requirements of synchronous speed and fixed length, the speed has to be stable. The arc length between cutter ends (Figure 7.3.7.8) and the cutting length proportion will determine the speed variation. The larger the value, the greater the variation. If each arc length between cutters is longer than the cutting length, the motor speed is faster than the master axis before entering the synchronous speed zone. So, the motor needs to decelerate to the master axis speed, as shown in Figure 7.3.7.5 (a). If the arc length between cutters is shorter than the cutting length, the motor speed is slower than the master axis before entering the synchronous speed zone. Therefore, the motor needs to accelerate to the master axis speed, as shown in Figure 7.3.7.5 (b).



(a) Arc length between cutter ends > cutting length (b) Arc length between cutter ends < cutting length

Figure 7.3.7.5 Correlations between the cutting length, speed, and arc length between cutter ends

You can adjust the cutting length by changing the cutter rotation speed. However, the larger the synchronous speed zone, the less flexibility to adjust the cutting length. As shown in Figure 7.3.7.6, the cutting length is the same, meaning the rotation distances of the pointed cutter and wide blade cutter are the same (measure of the speed curve area). When you use a wide blade cutter, the non-synchronous speed zone is larger and requires an abrupt acceleration or deceleration, which may easily make the motor reach the maximum torque limit. When the cutter cannot cut the material with a shorter length due to the cutter speed or the maximum current limit, increase the cutter number to shorten the operation distance per cutting, making the cutter slower and the current output lower.

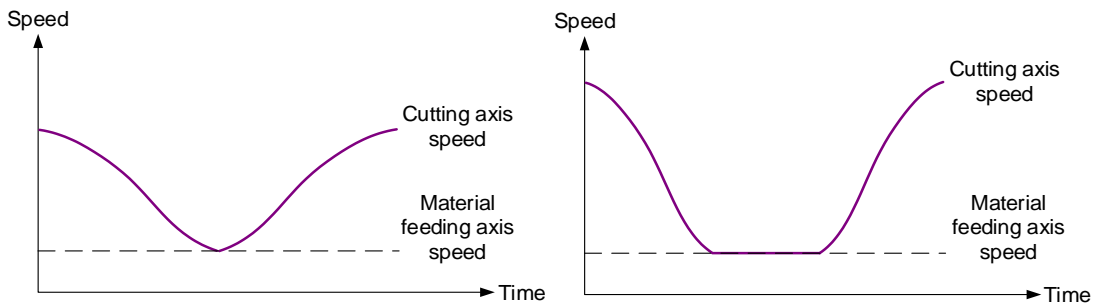

(a) Pointed cutter (small synchronous speed zone) (b) Wide blade cutter (large synchronous speed zone)

Figure 7.3.7.6 Size of the synchronous speed zone and motor speed

To avoid drastic speed change during operation, when plotting the system, take the arc length between cutter ends, cutting length, and the synchronous speed zone into consideration. The synchronous speed zone is fixed based on the machining requirements for the materials; whereas the cutting length is determined by the acceleration and deceleration zones. Therefore, in addition to the cutter diameter, the cutter number can determine the speed and alleviate the speed variation caused by the acceleration or deceleration of the motor, which makes the system operation smoother. You can also use a lower power motor to have a more cost-effective servo system.

### Create an E-Cam curve

You can plot the E-Cam curve for the rotary shear system through ASDA-Soft or macros of the servo drive. There are four methods to create E-Cam curves for rotary shear applications. [Rotary Shear - W/O Sync. Zone], [Rotary Shear - Fixed Sync. zone], and [Rotary Shear - Adjustable Sync. Zone] are designed for common rotary shear applications. The differences among the three are whether there is a synchronous speed zone and whether this zone is adjustable. [Rotary Shear - Printing Machine] is specially designed for creating curves for printing machines. Two macros provided by the servo drive are available for creating E-Cam curves. Macro #6 can create E-Cam curves with fixed synchronous speed zone and Macro #7 can create E-Cam curves with adjustable synchronous speed zone for rotary shear applications. The required setting parameters and the rotary shear mechanical structure are shown in Figure 7.3.7.7.

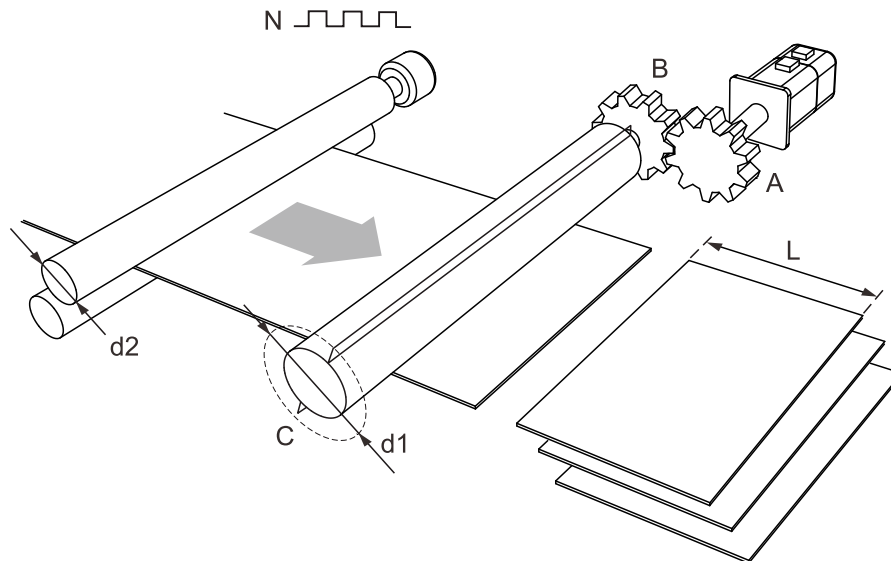

N: pulse number per encoder revolution  
 A: gear teeth number of the motor; B: gear teeth number of the cutter  
 L: cutting length; C: number of cutters  
 d1: cutter diameter; d2: encoder diameter

Figure 7.3.7.7 Mechanical structure of rotary shear

- Create E-Cam curves without synchronous speed zone

This kind of E-Cam curve is only suitable for applications using pointed cutters and can only be created by ASDA-Soft. The setting interface is shown in Figure 7.3.7.8. The specification settings for the rotary shear are as follows:

1. Gear teeth ratio: set the gear teeth number of the motor (A) and gear teeth number of the cutter (B).
2. Number of cutters (C): set the cutter number based on the rotary shear mechanism.
3. Cutter diameter (d1): set the cutter diameter based on the rotary shear mechanism.  
The cutter radius is the distance from the cutter shaft center to the cutter end; the cutter diameter is two times of the cutter radius. This value does not change with the cutter number and the software will calculate the circumference drawn by the cutter end.
4. Encoder diameter (d2) and encoder pulse number (N): set the diameter and pulse per encoder revolution. The command resolution can be calculated with these two values.  
If you know the master axis' gear ratio, entering the encoder diameter and pulse number are not required. You can simply input the values for P5.083 and P5.084.
5. PUU number per motor revolution: set the PUU number per motor revolution (slave axis) after E-Gear ratio conversion (P1.044 / P1.045).
6. Cutting length (L): set the material cutting length. To avoid generating an unsuitable rotary shear curve, the software automatically limits the cutting length by referring to the ratio (R) of the cutting length (L) and the arc length between cutter ends (a);  $R = L / a$ ;  $R = 0.3 - 3$ .

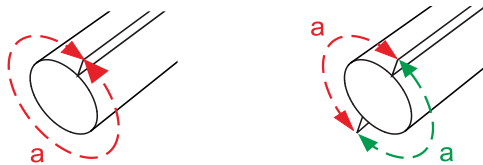

Figure 7.3.7.8 Arc length between cutter ends

- Speed compensation ( $V_c$ ): in some rotary shear applications, the speeds of the master and cutter axes are different during cutting; so you can use speed compensation to change the speed of the cutter axis. In the cutting zone, if the speed compensation value is positive, the cutter axis speed is faster than the master axis; if the speed compensation value is negative, the cutter axis speed is slower than the master axis.

7

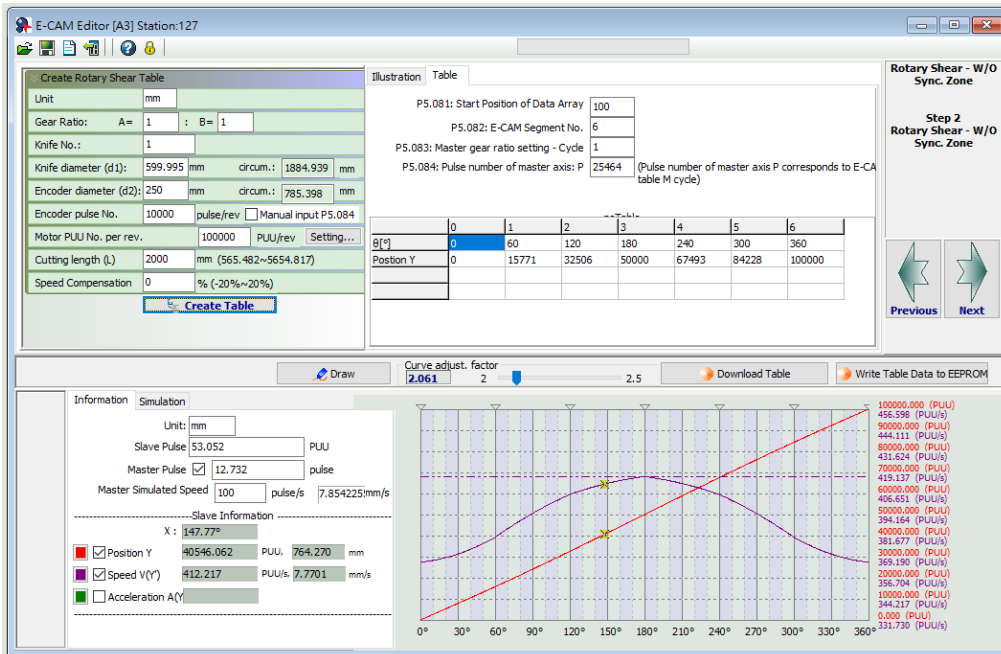

Figure 7.3.7.9 ASDA-Soft setting interface for [Rotary Shear - W/O Sync. Zone]

7

■ Create E-Cam curve with fixed synchronous speed zone

This method allows you to create a rotary shear curve with fixed synchronous speed zone, which range is fixed to 51°. You can use ASDA-Soft to create the table, which parameter setting is similar to the curve for rotary shears without synchronous speed zone, as shown in Figure 7.3.7.10. The software automatically limits the cutting length by referring to the ratio (R) of the cutting length (L) and the arc length between cutter ends (a);  $R = L / a$ ;  $R = 0.07 - 2.5$ .

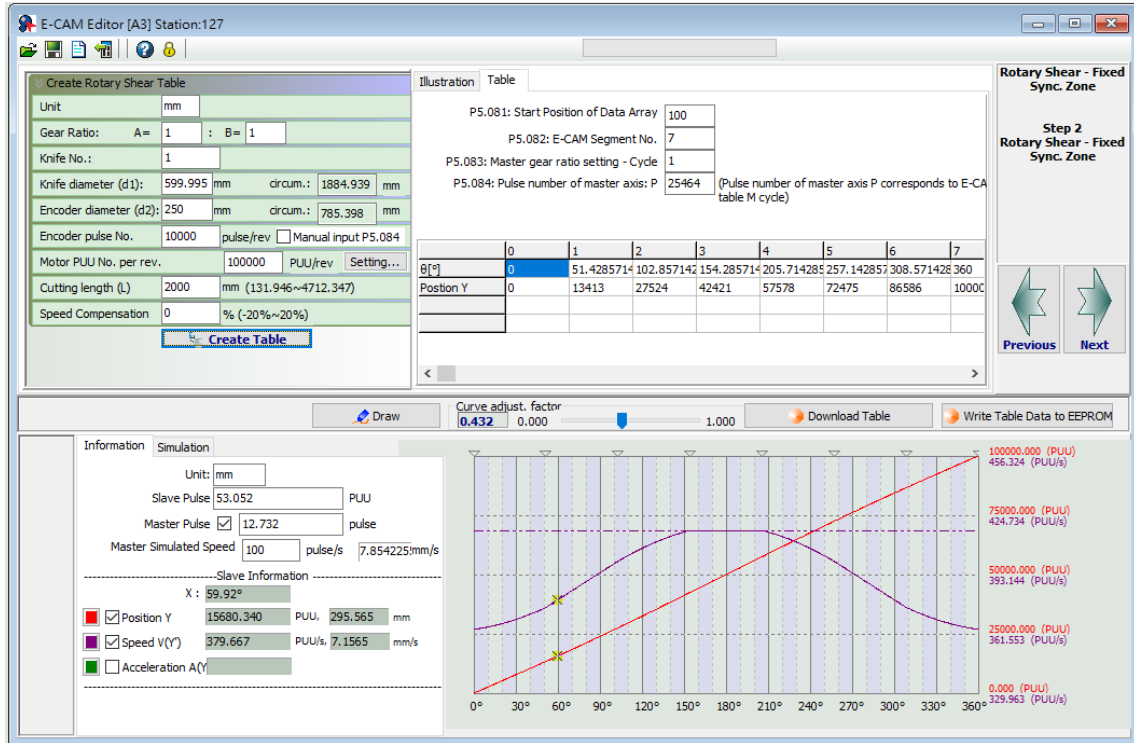

Figure 7.3.7.10 ASDA-Soft setting interface for [Rotary Shear- Fixed Sync. Zone]

You can use Macro #6 of the servo drive to create the table with the same method and the curve created is the same as that generated with ASDA-Soft. The advantage of using the macro to create an E-Cam curve is that when changing the cutting length is required, you can create a new curve simply by modifying the parameters. It is very friendly for those applications that require frequent modification of the cutting length. The setting steps are as follows:

1. Set the start position for the data array: use P5.081 to specify the data array start position for E-Cam and use P5.085 to set the E-Cam's segment number for clutch engagement. When Macro #6 is used, P5.082 E-Cam segment number can only be 7, which means the curve resolution is 51° and the synchronous speed zone is also 51°.
2. Set the system E-Gear ratio: set the system E-Gear ratio with P1.044 and P1.045.
3. Set the E-Cam's gear ratio and curve scaling: set the pulse number required for the cutting length, which is  $P5.083 = 1$  and

$$P5.084 = \frac{\text{Pulse number per revolution of the master axis encoder } N}{\pi \times \text{master axis encoder diameter } d2(mm)} \times \text{Cutting length } L(mm).$$

Use P5.019 to specify the E-Cam curve scaling.

4. Set parameters for creating the E-Cam curve table:

P5.094 = Motor gear teeth number (A) × Cutter number (C)

P5.095 = Cutter gear teeth number (B)

$$P5.096 = \frac{\text{Cutting length } L(mm)}{\pi \times \text{cutter diameter } d1(mm)} \times \text{Cutter number } C \times \text{Speed compensation } V_c \times$$

1000000.

If  $V_c = 1$ , there is no speed compensation. If  $V_c = 0.9$ , the speed of the cutter axis in the synchronous speed zone is 0.9 times of the master axis speed. If  $V_c = 1.1$ , the speed of the cutter axis in the synchronous speed zone is 1.1 times of the master axis speed.

5. Enable Macro #6: write 0x0006 to P5.097 to enable Macro #6. Read P5.097 and if it returns 0x1006, it means using macro for table creation is successful. If any of the following failure codes shows, modify the setting according to the description.

Failure code	Description
0xF061	The clutch is engaged, so the E-Cam table cannot be created.
0xF062	Data of P5.094 exceeds the range (1 - 65535).
0xF063	Cutter number set in P5.095 exceeds the range (1 - 65535).
0xF064	Data of P5.096 exceeds the range (300000 - 2500000).
0xF065	P5.081 data array start position exceeds the array length.
0xF066	P5.082 E-Cam segment number must be set to 7.
0xF067	The set values of P1.044 and P1.045 for the E-Gear ratio are too high. Decrease the values of P1.044 and P1.045, but maintain the same ratio, for example: adjust 167772160 : 1000000 to 16777216 : 100000.



7

- Create E-Cam curve with adjustable synchronous speed zone

This table creation method is for generating an E-Cam curve with adjustable synchronous speed zone. You can use ASDA-Soft to create the table. The parameter setting for the rotary shear curve is similar to the setting of that without the synchronous speed zone, as shown in Figure 7.3.7.11. The software automatically limits the cutting length by referring to the ratio (R) of the cutting length (L) and the arc length between cutter ends (a);  $R = L / a$ .  $1.88 > R \times \text{Speed compensation } (V_c)$ .

The difference from the rotary shear curves without the synchronous speed zone is you can plot the acceleration, synchronous speed, and S-curve zones for the curves with adjustable synchronous speed zone. If the deceleration zone size is the same as the acceleration zone, the software defines the remaining part as the waiting zone.



Figure 7.3.7.11 ASDA-Soft setting interface for [Rotary Shear - Adjustable Sync. Zone]

You can use Macro #7 of the servo drive to create the table with the same method. The advantage of using the macro to create an E-Cam curve is that when changing the cutting length is required, you can create a new curve simply by modifying the parameters. It is very friendly for those applications that require frequent modification of the cutting length. The setting steps are as follows:

1. Set the start position for the data array: use P5.081 to specify the data array start position for E-Cam and use P5.085 to set the E-Cam's segment number for clutch engagement. When Macro #7 is used, the range of E-Cam segment (P5.082) is 30 - 72. It is suggested that you set the segment to 72 for the optimal resolution of 5°.
2. Set the system E-Gear ratio: set the system E-Gear ratio with P1.044 and P1.045.
3. Set the E-Cam's gear ratio and curve scaling: set the pulse number required for the cutting length, which is  $P5.083 = 1$  and

$$P5.084 = \frac{\text{Pulse number per revolution of the master axis encoder } N}{\pi \times \text{master axis encoder diameter } d2(mm)} \times \text{Cutting length } L(mm).$$

Use P5.019 to specify the E-Cam curve scaling.

4. Set the parameters for the E-Cam curve zones: specify the size of the waiting, acceleration, synchronous speed, and S-curve zones. P5.093.DCBA sets the S-curve level (S) with the range of 1 - 4; the calculation for the corresponding angle (S°) is as follows. P5.093.UZYY sets the angle (W) of the waiting zone with the range of -1° to 170° in hexadecimal. If you enter -1 (0xFFFF), it means the cutter speed is 0 in the waiting zone and the angle for the waiting zone is calculated by the servo drive. P5.094 sets the angle (Y) of the synchronous speed zone with the range of 0° - 330° in decimal format. The acceleration zone is automatically calculated by the servo drive, as shown in the following formula.

$$S^\circ = \frac{2^S \times 360^\circ}{\text{E - Cam segment number } P5.082}$$

$$360^\circ = 2W + 2Acc + 2S^\circ + Y$$

As the synchronous speed zone is adjustable, there are limitations when using Macro #7 to create the waiting zone of the E-Cam curve. The conditions are as follows.

$$\widehat{W}(\text{minimum waiting zone}) = 180^\circ + \frac{360^\circ}{P5.082} - \frac{360^\circ}{R} + \frac{Y}{2}$$

7

If the waiting zone ( $W$ ) < minimum waiting zone ( $\widehat{W}$ ), the error code 0xF07A returns, and you must increase the waiting zone or decrease the synchronous speed zone. If the waiting zone ( $W$ ) = minimum waiting zone ( $\widehat{W}$ ), the cutter speed is 0 at the waiting zone. If the waiting zone ( $W$ ) > minimum waiting zone ( $\widehat{W}$ ), the cutter axis speed is greater than 0 at the waiting zone.

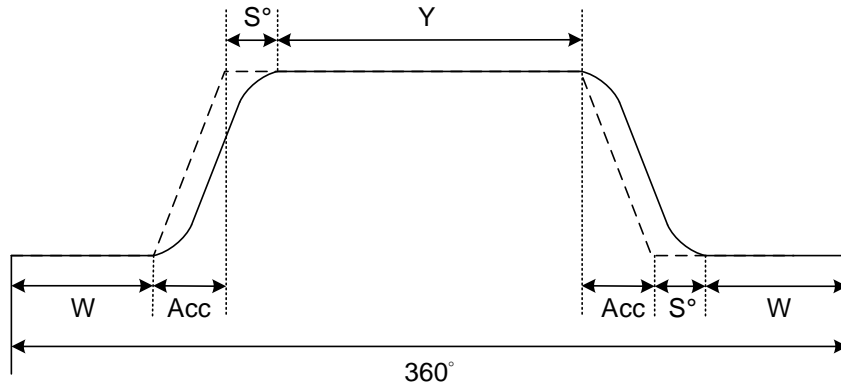

- Set the parameters for creating the E-Cam curve table:

P5.095.DCBA = Motor gear teeth number (A) × cutter number (C) in decimal format.

P5.095.UZYX = Cutter gear teeth number (B) in decimal format.

For example, if the motor gear teeth number A = 10, cutter number C = 1, and cutter gear teeth number B = 1, then P5.095 = 0x000A0001 (HEX). In this case, you need to set P5.095 to 655361 (DEC);

$$P5.096 = \frac{\text{Cutting length } L(mm)}{\pi \times \text{cutter diameter } d1(mm)} \times \text{Cutter number } C \times \text{Speed compensation } V_c \times 1000000.$$

If  $V_c = 1$ , there is no speed compensation.

If  $V_c = 0.9$ , the speed of the cutter axis in the synchronous speed zone is 0.9 times of the master axis speed.

If  $V_c = 1.1$ , the speed of the cutter axis in the synchronous speed zone is 1.1 times of the master axis speed.

6. Enable Macro #7: write 0x0007 to P5.097 to enable Macro #7. Read P5.097 and if it returns 0x1007, it means using macro for table creation is successful. If any of the following failure codes shows, modify the setting according to the description.

Failure code	Description
0xF071	The clutch is engaged, so the E-Cam table cannot be created.
0xF072	Degree of synchronous area of P5.094 exceeds the range (0° - 330°).
0xF073	S-curve level of P5.093.DCBA (HEX) exceeds the range (1 - 4).
0xF074	Degree of waiting zone of P5.093.UZYX (HEX) exceeds the range (-1° to 170°).
0xF075	Data of P5.096 exceeds the range (50000 - 5000000).
0xF076	E-Cam segment number of P5.082 exceeds the range (30 - 72).
0xF077	P5.081 data array start position exceeds the array length.
0xF078	The set values of P1.044 and P1.045 for the E-Gear ratio is too high. Decrease the values of P1.044 and P1.045, but maintain the same ratio, for example: adjust 167772160 : 1000000 to 16777216 : 100000.
0xF079	Acceleration degree is too small. Decrease the value for the waiting zone, synchronous speed zone, or S-curve level.
0xF07A	Waiting zone < minimum waiting zone. Increase the value for the waiting zone or decrease the value for the synchronous speed zone.

The following method helps you to test the maximum border condition and create the E-Cam curve successfully when using the HMI or controller to create the E-Cam table.

If the ratio (R) of the cutting length (L) and the arc length between cutter ends (a) is 0.05 - 1.09 (R = 0.05 - 1.09), and the E-Cam segment number P5.082 = 72, follow the parameter setting procedure to create the table with Macro #7.

1. Set the waiting zone (W) and synchronous speed zone (Y) based on the S-curve level:

S-curve level (S)	Range of waiting zone (W) and synchronous speed zone (Y)
1	$0^\circ \leq W \leq 75^\circ; 0^\circ \leq Y \leq 150^\circ$
	$0^\circ \leq 2W+Y \leq 300^\circ$
2	$0^\circ \leq W \leq 70^\circ; 0^\circ \leq Y \leq 150^\circ$
	$0^\circ \leq 2W+Y \leq 290^\circ$
3	$0^\circ \leq W \leq 55^\circ; 0^\circ \leq Y \leq 110^\circ$
	$0^\circ \leq 2W+Y \leq 220^\circ$
4	$0^\circ \leq W \leq 25^\circ; 0^\circ \leq Y \leq 30^\circ$
	$0^\circ \leq 2W+Y \leq 80^\circ$

2. Write the corresponding parameters: P5.093.DCBA = S-curve level (S); P5.093.UZYX = Angle of the waiting zone (W) set in hexadecimal; P5.094 = Synchronous speed zone (Y); other parameter settings for curve table creation are the same as Step 5 mentioned earlier. Set P5.097 to 7 to enable Macro #7.

## 7

If the ratio (R) of the cutting length (L) and the arc length between cutter ends (a) is 1.1 - 5 (R = 1.1 - 5), and the E-Cam segment number P5.082 = 72, follow the parameter setting procedure to create the table with Macro #7.

1. Set the S-curve level: use macro parameter P5.093.DCBA to set the S-curve level (S) with the range of 1 - 4.
2. Set the synchronous speed zone: use macro parameter P5.094 to set the angle of the synchronous speed zone (Y). Its angle must be greater than 0. When the synchronous speed zone ( $Y_{Max}$ ) calculated by the following formula is less than 0 degree, decrease the S-curve level.

$$Y_{Max} = \frac{360}{R} - 5 \times (3 + 2^{s+1}) \geq 0$$

3. Set the waiting zone: use macro parameter P5.093.UZYX in hexadecimal to set the angle of the waiting zone (W). The calculation is as follows.

$$W \text{ (Hex)} = 180 - \frac{180}{R} - \frac{5 \times (2^{s+1} - 1)}{2}$$

When the machine is cutting, if the cutter speed is faster than the material feeder, it means the speed compensation ( $V_c$ ) is greater than 1. Proceed to Step 4 and re-plan the synchronous speed and waiting zones based on the speed compensation requirements. If the cutter is slower than the material feeder, it means the speed compensation is equal to or less than 1. Proceed to Step 6, set the mechanism related parameters, and enable Macro #7 to complete the E-Cam curve creation.

- If taking adjusting the cutter speed as the priority, set the required maximum speed compensation and use this compensation value to re-calculate the Sync zone ( $Y_{new}$ ) and the Waiting zone ( $W_{new}$ ). If taking the Sync zone size as the priority, set the Sync zone ( $Y_{new}$ ) and use the size of this Sync zone to re-calculate the speed compensation value and the Waiting zone ( $W_{new}$ ). Refer to the following formulas to calculate the synchronous speed zone and speed compensation value.

Priority	Calculation 1	Calculation 2
Adjust cutter speed	Use the speed compensation ( $V_c$ ) to calculate the variation of the Sync zone ( $\Delta Y$ ): $\Delta Y = \frac{360}{R} \times \left(1 - \frac{1}{V_c}\right)$	New Sync zone size ( $Y_{new}$ ): $Y_{new} = Y - \Delta Y$
Sync zone size	Use the new Sync zone size ( $Y_{new}$ ) to calculate the variation of the Sync zone ( $\Delta Y$ ): $Y > Y_{new}$ $\Delta Y = Y - Y_{new}$ $Y_{new} \geq P5.094 \geq 0$	Speed compensation ( $V_c$ ): $V_c = \frac{360}{360 - \Delta Y \times R}$

- Set the new waiting zone size: use the macro parameter P5.093.UZYX in hexadecimal to set the re-calculated waiting zone angle ( $W_{new}$ ), as shown in the following formula.

$$W_{new} = W + \frac{\Delta Y}{2}$$

- Set the parameters related to the mechanism and enable Macro #7: use the macro parameter P5.095.DCBA in hexadecimal to set the motor gear number (A) × Cutter number (C). Use the macro parameter P5.095.UZYX in hexadecimal to set the cutter gear number (B). Set P5.096 to 1000000 × Ratio of the cutting length and arc length between two cutter ends (R) × Speed compensation ( $V_c$ ). Set P5.097 = 0x0007 to enable Macro #7 to complete the E-Cam curve for the adjustable synchronous speed zone.

7

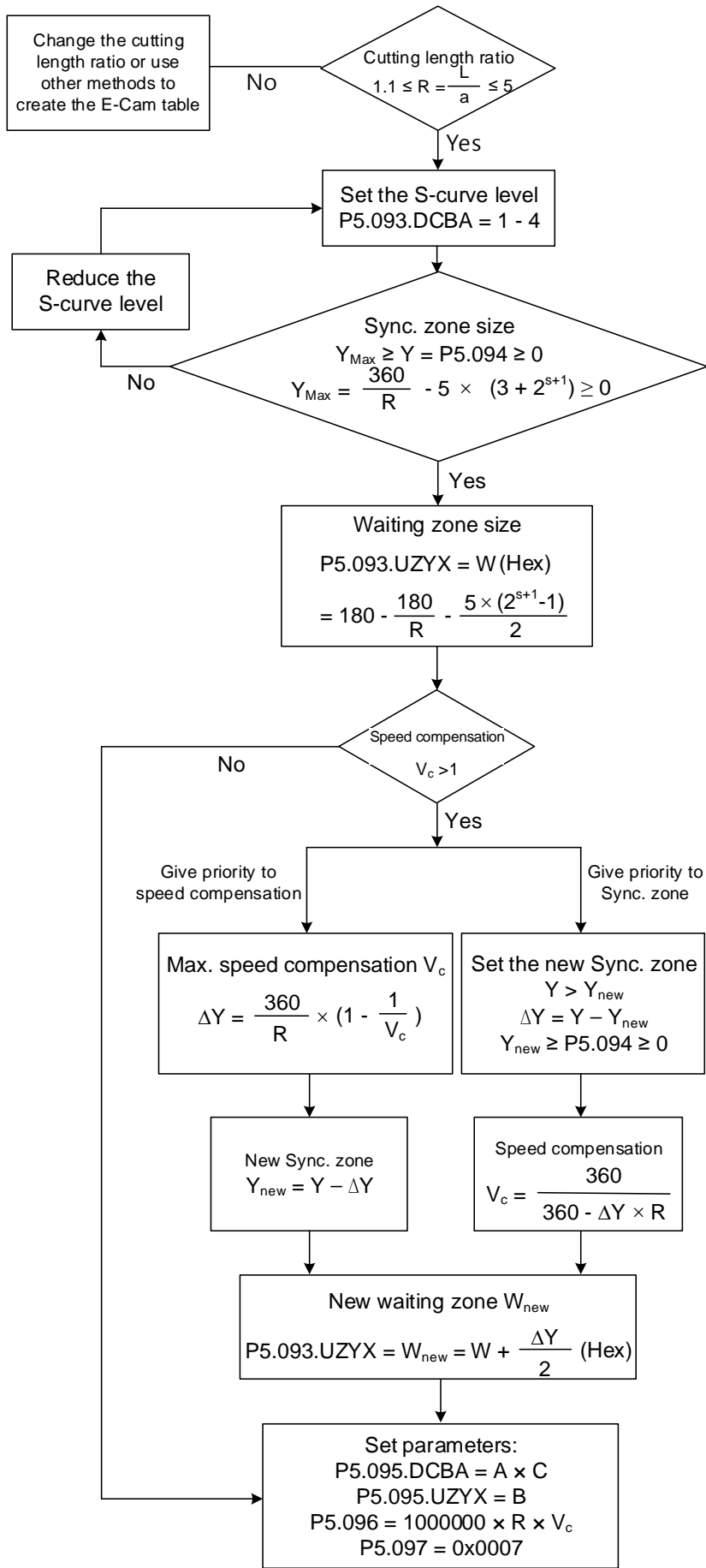

■ Create E-Cam curve for periodic intermittent printer

Use this type of E-Cam curve when the printing material length is limited and full print cannot be carried out. This type of curve helps to save the material, decreasing the interval between each print pattern by retracting the material when the printing plate detaches from the material. In the case of paper printing, the printing axis rotates at a fixed speed in a single direction. When the printing plate and paper come into contact, the paper and printing axis starts printing with the same linear speed, as shown in Figure 7.3.7.12 (a). Once the printing motion stops and during the interval when the printing plate and paper are separated, the drive roll starts decelerating and moving in the opposite direction until reaching the specified zone, as shown in Figure 7.3.7.12 (b). Afterwards, the drive roll resumes operation in the printing direction. When the printing plate and paper come into contact again, the paper and printing axis resume a synchronous relation and make the next print. Regarding the E-Cam curve for intermittent printing machines, the parameters that you must set and the corresponding relation with the printing machine mechanical structure are shown in Figure 7.3.7.13.

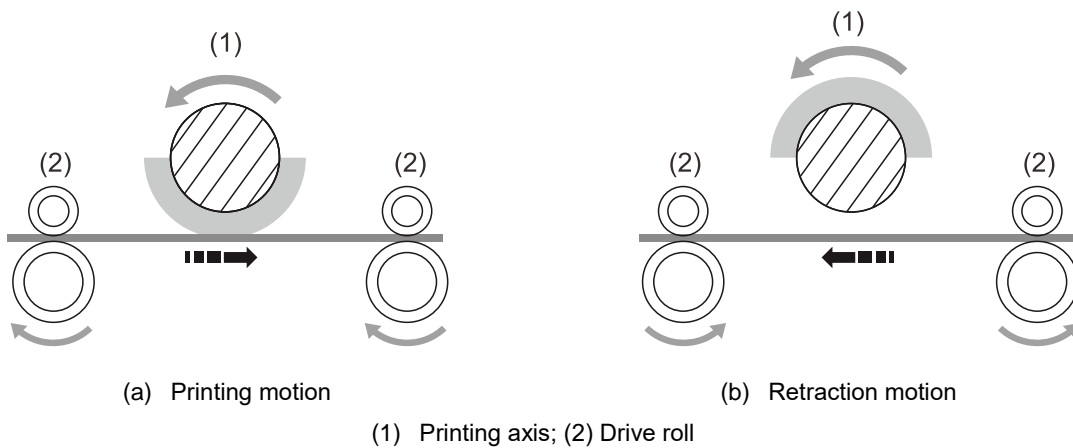
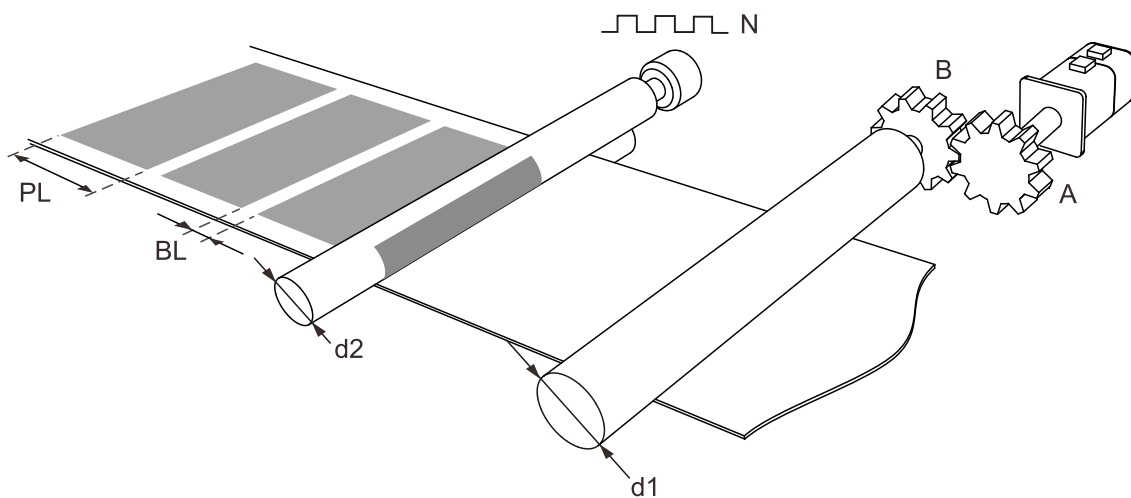

Figure 7.3.7.12 Intermittent printing machine



N: number of pulses per printing axis revolution  
 A: number of gear teeth on motor; B: number of gear teeth on material feeder  
 PL: print length; BL: blank length  
 d1: drive roll diameter; d2: printing axis diameter

Figure 7.3.7.13 Printing machine mechanical structure



7

You can create the E-Cam curve table for intermittent printer by using the ASDA-Soft software. Figure 7.3.7.14 shows the user setting interface. The printer specification settings are as follows.

1. Gear ratio: set the number of motor gear teeth (A) and number of material feeder gear teeth (B).
2. Print length (PL) and blank length (BL): set the print length and blank length.
3. Drive roll diameter (d1): set the drive roll diameter for conveying the material.
4. Printing axis diameter (d2) and printing axis pulse number (N): set the diameter of master printing axis and number of pulses per revolution.

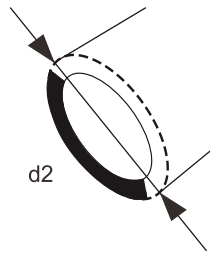

5. Number of PUU per motor revolution: set the number of PUU per motor revolution of the drive roll after E-Gear ratio conversion ( $P1.044 / P1.045$ ).

The ratio of printing axis circumference to printing zone length ( $R = \frac{\pi \times d_2}{PL+BL}$ ) must exceed 1 when E-Cam curves are used for intermittent printing machines in order to save the material.

Calculate the synchronous speed zone angle with the formula  $Y = \frac{PL}{\pi \times d_2} \times 360^\circ$ . You can also adjust the waiting zone angle and S-curve angle in the advanced settings. Increase the angle for the synchronous speed zone to increase the zone size. This ensures the printing axis and drive roll are in the uniform operation speed and stable during ACC printing motions to achieve higher quality printing.

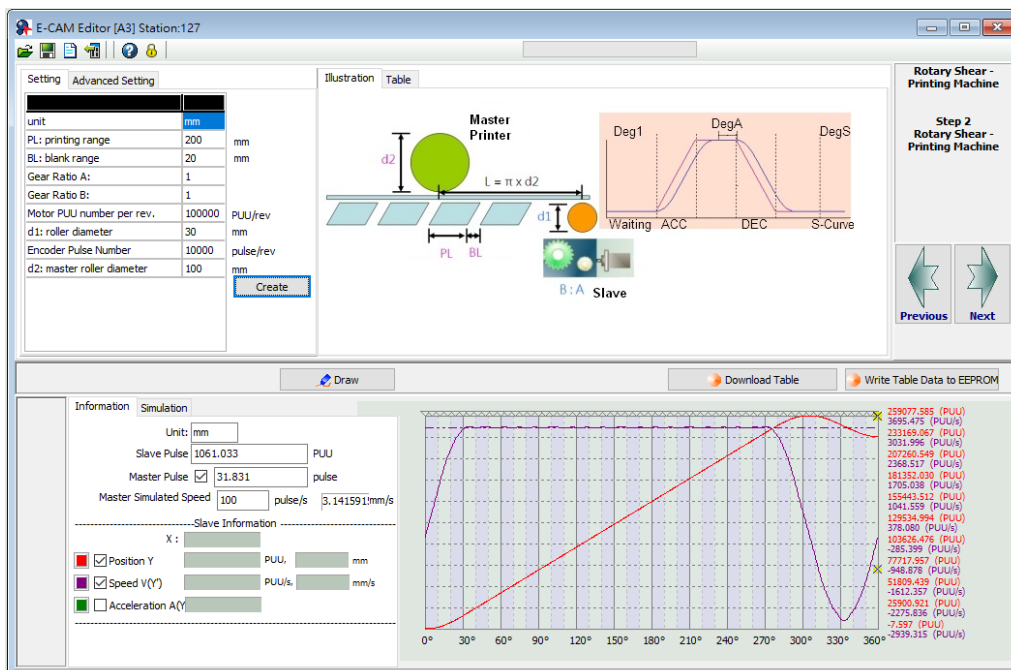

Figure 7.3.7.14 ASDA-Soft rotary shear - intermittent printing machine setting interface

### Synchronous Capture axis

In rotary shear applications, the system needs to automatically compensate the mechanical or material differences in order to ensure the cutting spot is correct. Delta servo drive provides 2 types of compensation functions, synchronous Capture axis and E-Cam phase alignment. The introduction of the synchronous Capture axis is as follows. After the external sensor detects the alignment mark, it sends the digital input signal (DI7) to the slave servo axis through the hardware wiring. The servo drive compensates the position error according to the deviation between the set pulse number and the pulse number actually received, and then corrects the cutting or packing positions until it is within the set zone. You can use the synchronous Capture axis for compensation if deformation and slippage occur in either the cutter or film of the packing machine. Reasons that may cause inaccurate cutting are as follows:

1. Loss of pulse: unstable pulse output from the master axis or the slave axis is unable to properly receive pulses from the master axis due to noise or other factors.
2. Errors accumulated over long periods of time: significant calculation error due to the number of pulses accumulated over long periods of time.
3. Material slippage: relative slippage between material and roller causing inaccurate cutting length.
4. Nature of the material: different tension between materials wound onto the inner circle and outer circle.
5. Tension mechanism causing material deformation: material deformed due to the tension mechanical design of the machine causing inaccurate cutting length.
6. Alignment mark position: printing or other factors may cause inconsistent spacing between marks.

#### ■ Compensation mechanism of synchronous Capture axis

The servo drive uses the deviation between the pulse number within two marks set in P5.078 and the actual received pulses within two marks as the basis for correction. Next, the servo drive calculates the pulse number of the synchronous Capture axis and regards it as the source for the master axis. The deviation is saved in P5.079. You can directly write the deviation into this parameter to shift the cutting or packaging spot. You can also shift the cutting or packaging spot by writing the shift compensation deviation in P1.016, so that the cutting or packaging spot shifting amount is value of P5.079 plus P1.016. During synchronous Capture axis operation, the deviation in P5.079 remains within a small range. If the deviation increases constantly, it may be caused by mechanism deviation, signal interference, or inappropriate parameter settings. In this case, set the correction rate and correction rate filter with P5.080 and P1.015. The larger the correction rate, the faster the synchronous deviation is corrected to 0, but the speed changes more drastically. In contrast, the smaller the correction rate, the slower the synchronous deviation is corrected to 0, and the speed changes more moderately. The compensation mechanism is shown in Figure 7.3.7.15.

7

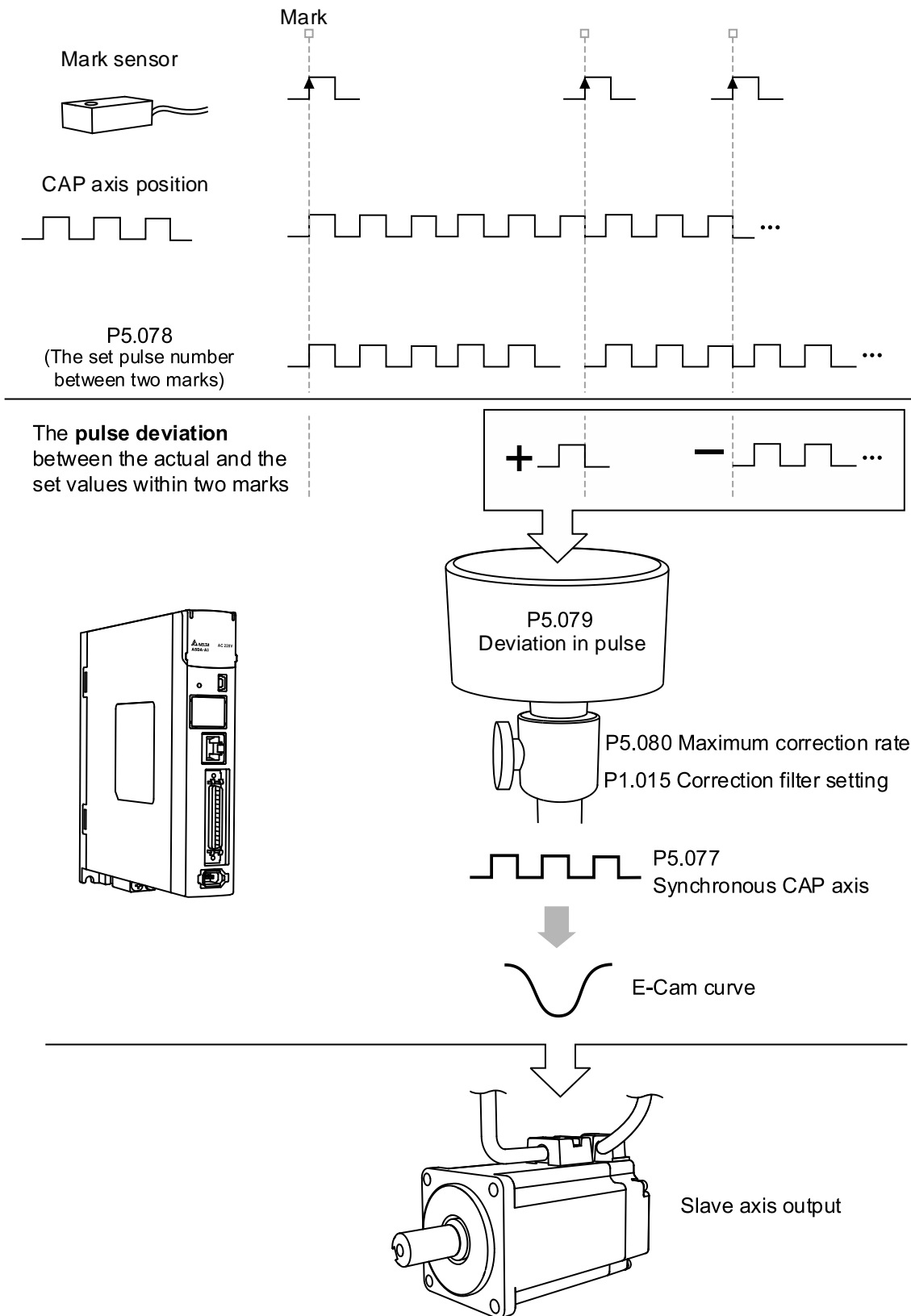

Figure 7.3.7.15 Synchronous Capture axis compensation

The formula for the synchronous Capture axis correction rate is as follows. You can use P5.080 to modify the correction rate.

$$(100 - P5.080)\% < \text{Correction rate} = \frac{\text{Sync CAP axis output pulse}}{\text{Sync CAP axis input pulse}} < (100 + P5.080)\%$$

The synchronous Capture axis is for correcting the accumulated deviation. Use the mean filter if immediate correction for the subtle deviation is necessary. The correction filter P1.015 can set the range for enabling the filter. If the error is within the set range, the filter is enabled. If the error is greater than the set value of P1.015, it means E-Cam deviation is too great and must be corrected immediately instead of being filtered. Its operation is shown in Figure 7.3.7.16.

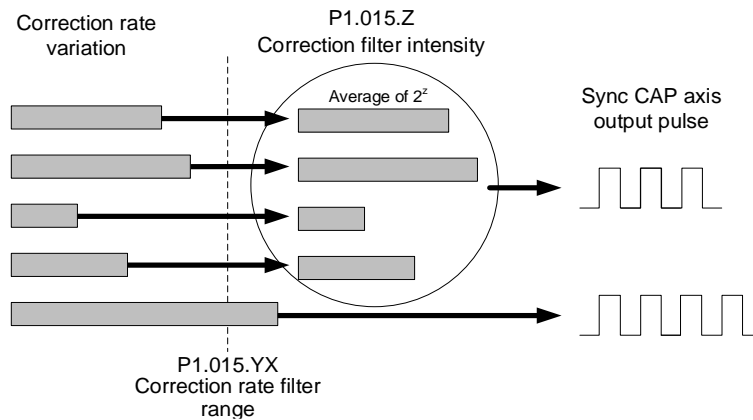
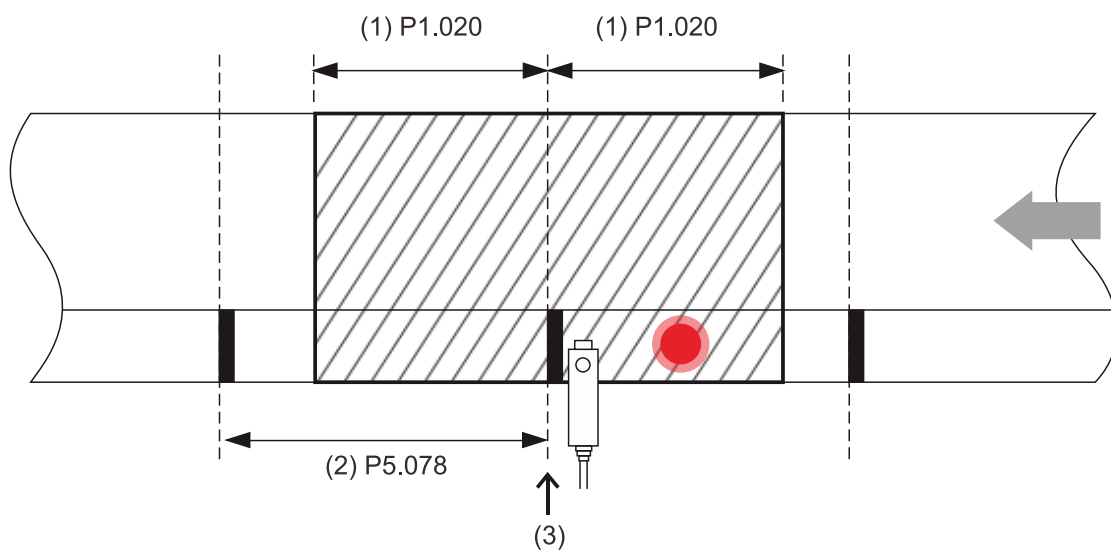

Figure 7.3.7.16 Correction filter of synchronous Capture axis

When the mark printing quality is inferior and there is a stain on the non-mark reading area, the synchronous Capture axis can perform the masking function with high speed position capturing. To avoid misreading the mark due to stains, use P1.020 to specify the distance in pulses for disabling the Capture function before and after reading the mark reading area, as shown in Figure 7.3.7.17.



- (1) P1.020 masking pulse number
- (2) P5.078 pulse number between two marks
- (3) Capture the mark and mask the area

Figure 7.3.7.17 Capture masking function

# 7

■ Settings for synchronous Capture axis

Before using the synchronous Capture axis, set the parameters for E-Cam, E-Cam curves, and the synchronous Capture axis. Next, use PR commands to enable the Capture and E-Cam functions. The settings are as follows.

1. Create and download the E-Cam curve to the servo drive.
2. Set the E-Gear ratio: including the system E-Gear ratio (P1.044 and P1.045), E-Cam gear ratio (P5.083 and P5.084), and E-Cam curve scaling (P5.019).
3. Relevant settings for E-Cam: start address for data array (P5.081), segment number N (P5.082), and engaged segment number (P5.085).
4. Relevant settings for high speed position capturing (Capture) : start address of data array (P5.036) and masking range (P1.020).
5. Set the homing methods.
6. Relevant settings for synchronous Capture axis: the interval between each synchronous Capture action (P5.078) must be equal to the received pulse number per E-Cam cycle (P5.084/P5.083), maximum correction rate (P5.080), and correction filter (P1.015).
7. Set the PR command to enable the Capture and E-Cam functions: PR#0 executes the homing procedure. PR#1 uses the absolute position command to move the motor to the origin. Disable the Capture and E-Cam functions before using the PR command to set their parameters, such as the case in PR#2 and PR#3. PR#4 sets the capturing amount. PR#5 enables the cyclic capturing mode. PR#6 enables the E-Cam function, uses the synchronous Capture axis as the source for the master axis, and executes the capturing action based on the clutch engagement timing. PR#7 enables the Capture function and sets the pulse source.

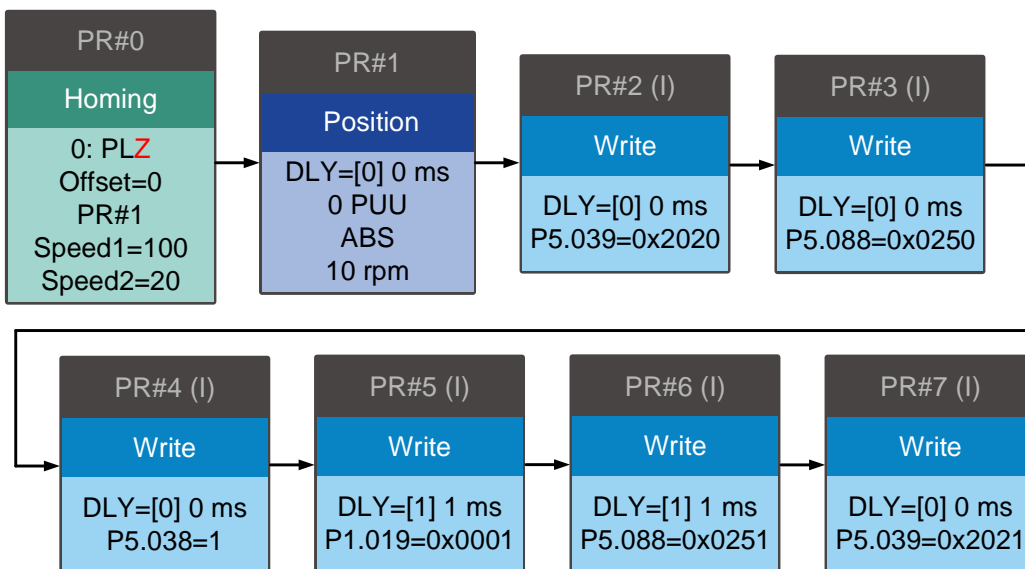

### E-Cam phase alignment

The E-Cam phase alignment function is another compensation method provided by the servo drive. You need to first set the phase for the E-Cam phase alignment and the compensation detection position for the external sensor. In each cycle, everytime the E-Cam operates to the detection position of the external sensor, the servo drive starts comparing the actual phase with the correct phase and then calculates the deviation of the slave axis. Then, the servo drive writes this deviation amount to the PR program for immediate or later compensation (user-defined), which is completed with the E-Cam and PR command overlapping function introduced in Section 7.3.5. The compensation mechanism for the E-Cam phase alignment is shown in Figure 7.3.7.18.

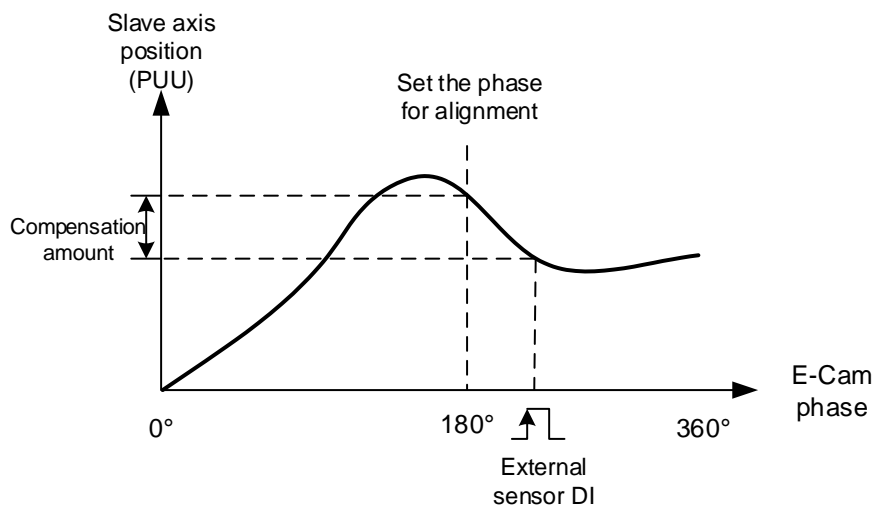

Figure 7.3.7.18 Compensation mechanism for phase alignment

#### ■ E-Cam phase alignment setting steps

When using the E-Cam phase alignment compensation, set the parameters for the DI (digital input), phase alignment position, and compensation level. The flowchart is shown in Figure 7.3.7.20. The steps to set the E-Cam phase alignment function are as follows.

1. Presetting: create and download the E-Cam curve to the servo drive. Set the E-Gear ratio, including the system E-Gear ratio (P1.044 and P1.045), E-Cam gear ratio (P5.083 and P5.084), and E-Cam curve scaling (P5.019). Complete the settings relevant to the E-Cam, including the start address of the data array (P5.081), E-Cam segment number (P5.082), and the E-Cam segment number for engagement (P5.085).
2. DI relevant settings: connect the external sensor with the DI point. Define this DI as [0x35]ALGN. Since both the DI and the sensor have delay, the captured phase position might also delay. Use P2.074 to set the delay time compensation of the DI as follows:

$$P2.074 = P2.009 \text{ (DI filter time)} + \text{Sensor delay time}$$

To prevent mistakenly triggering the DI, set P2.073.DC in hexadecimal to specify the masking zone proportion (%). The master axis pulse must exceed the masking area before the next phase alignment starts. This function is only applicable to the applications with forward direction pulse input.

The formula is as follows:

$$\text{Masking zone (pulse)} = \frac{P5.084}{P5.083} \times P2.073.DC(\%)$$

# 7

3. E-Cam phase alignment setting: P2.075 sets the alignment position for E-Cam phase alignment. The unit is the pulse number of the master axis, which corresponds to the specified E-Cam phase after conversion. For example, if the pulse number per E-Cam curve cycle is 36000, then P5.083 = 1 and P5.084 = 36000. If you set P2.075 to 18000, then upon the DI receives the signal, the system starts comparing the slave axis' actual position and the set E-Cam position of 180° and then calculates the required compensation value. If you set P2.075 to 10000, when the DI receives the signal, the system starts comparing the slave axis' actual position and the set E-Cam position of 100° and then calculates the required compensation value. Use the monitoring variable 063 (3Fh) to monitor the slave axis' actual position.
4. Filter setting: to keep the operation smooth and decrease the position deviation caused by the noise of the external sensor, when the distances between each mark read by the sensor are equal, you can use the filter to improve the stability of the phase alignment. P2.073.YX specifies the filter range (%) in hexadecimal. If the deviation is smaller than this set range, the filter function is effective. If the deviation is greater than this range, it means the deviation is greater and requires immediate compensation. P2.076.Y specifies the filter intensity. This works the same way as P1.015.Z, the correction filter intensity of the synchronous Capture axis, which setting value is suggested to be less than 3. Refer to Figure 7.3.7.15. Use the monitoring variable 085 (55h) to monitor the E-Cam phase deviation in percentage, which unit is 0.1%. If this value is 10, it means the deviation is 1%, which is 3.6°.
5. Compensation direction setting: P2.076.UZ specifies the allowable forward alignment rate in hexadecimal. Set it to 0% to perform the alignment always in the reverse direction; set 50% to align the phase with the shortest path; set 100% to perform the alignment always in the forward direction. When you select "always forward" or "always reverse" for the alignment, you must set the maximum correction rate to avoid excessive compensation. Generally, using the shortest path for alignment is recommended. If the application has set the reverse inhibit condition and the deviation is sometimes positive and sometimes negative, use with P1.022.U the reverse inhibit function.
6. Maximum correction rate setting: when the alignment deviation is too great, the compensation amount might thus be great which causes motor vibration or even overload. P2.073.UZ in hexadecimal sets the maximum correction rate and gradually compensates the deviation in stages to alleviate the motor vibration, but it requires longer time to complete the alignment compensation. The formula for maximum correction amount per time is as follows:

$$\text{Max. correction rate per time (pulse)} = \frac{P5.084}{P5.083} \times P2.073.UZ(\%)$$

7. PR path setting: the compensation amount for the slave axis is stored in the PR number specified by P2.073.BA. When the slave axis requires compensation, the system can trigger this PR path at the proper timing. When using the E-Cam phase alignment function, set the following for the specified PR: select [Point-to-Point Command], set NO for [INS: Interrupt the previous PR path when executing the current PR path], set NO for [OVL: allow the next PR command to overlap the command that is currently executed when decelerating], and select [INC Incremental position] and the appropriate speed and acceleration. Setting the position command is not required because it is automatically set by the E-Cam phase alignment function.

The screenshot shows the PR Mode configuration interface with the following settings:

- TYPE settings:** [2] :Point-to-Point Command
- OPT options:**
  - INS: Interrupt the previous PR path when executing the current PR path:  0:NO  1:YES
  - OVL: Allow the next PR command to overlap the command that is currently being executed when decelerating:  0:NO  1:YES
  - CMD: Position command types:
    - 00: ABS Absolute Position, CMD = DATA
    - 01: REL Relative Position, CMD = Current Position + DATA
    - 10: INC Incremental Position, CMD = Previous CMD + DATA
    - 11: CAP High Speed Position Capturing, CMD = Captured + DATA
- Speed and Time Setting:**
  - ACC: Time for accelerating to speed 5 m/s: AC00 : 200 (P5.020) Time=0.001 ms
  - DEC: Time for deceleration from speed 5 m/s: AC00 : 200 (P5.020) Time=0.001 ms
  - SPD: Target Speed: POV00 : 20.0 (P5.060)  x 0.1
  - DLY: Delay Time: DLY00 : 0 (P5.040)
- Data:**
  - Position CMD DATA(P.U): 0 (-2147483648 ~ 2147483647)

At the bottom, there is a 'Comment' field with the text 'Add note here!' and two buttons: 'Download' and 'Download All PR'.

8. E-Cam phase alignment setting: it is set by P2.076.X. P2.076.X Bit 0 enables or disables the alignment function. After this function is enabled, it starts operating as soon as the servo drive receives the DI signal. P2.076.X Bit 1 sets whether to immediately trigger the PR command and calls this PR command when the clutch disengages (P5.088.BA). P2.076.X Bit 2 selects the phase alignment method depending on whether the mark is on the compensated motion axis.



If the mark is on the non-compensation motion axis and when E-Cam phase alignment compensation is operating, the following mark position is unchanged. If the mark is on the compensation motion axis and when E-Cam phase alignment compensation is operating, the following mark position is changed, as shown in Figure 7.3.7.19.

7

(a) Mark on the non-compensation motion axis (P2.076.X Bit 2 = 0)

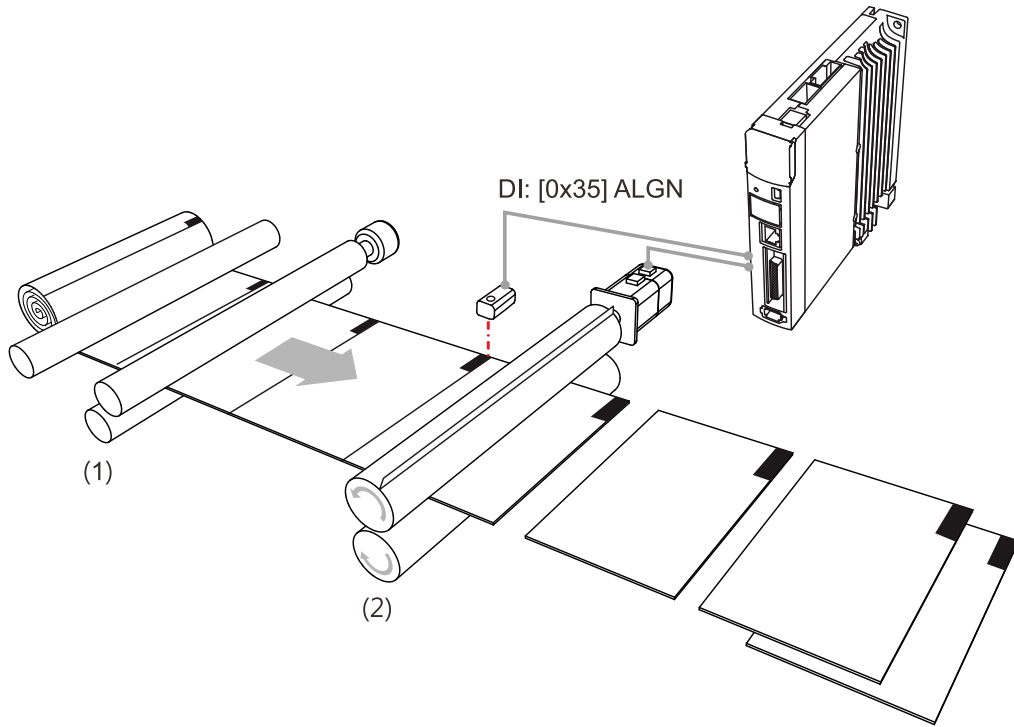

(b) Mark on the compensation motion axis (P2.076.X Bit 2 = 1)

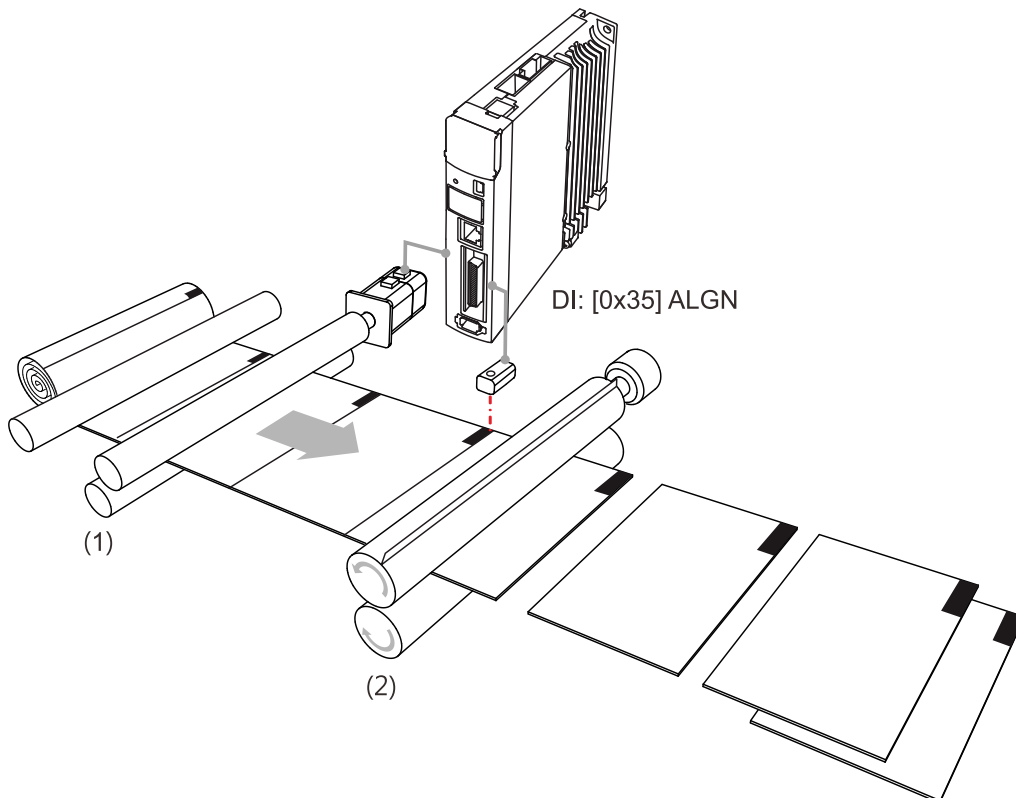

Figure 7.3.7.19 E-Cam phase alignment

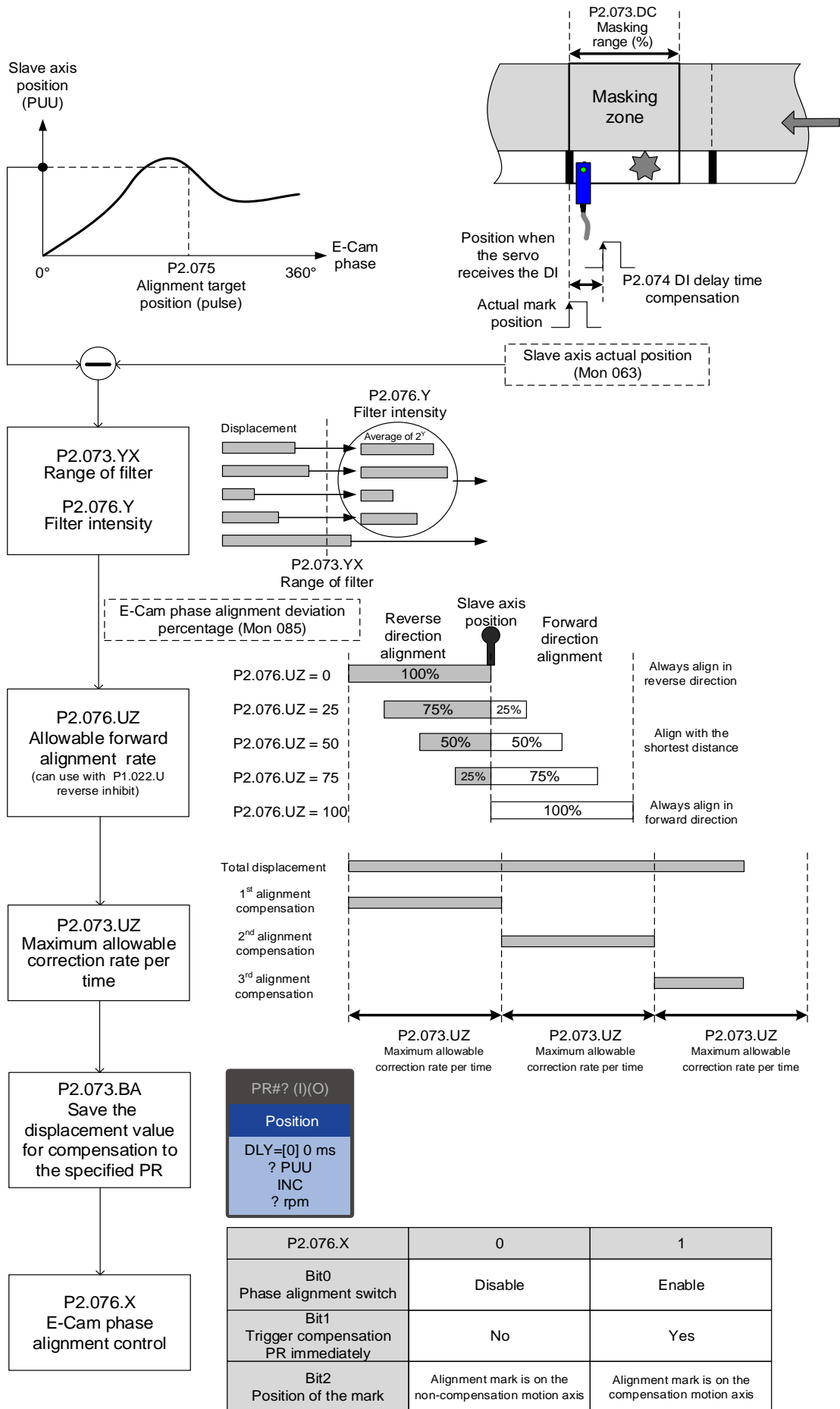

Figure 7.3.7.20 Phase alignment setting procedure

### Differences between positioning with synchronous Capture axis and E-Cam phase alignment

The synchronous Capture axis and E-Cam phase alignment are both commonly used compensation approaches for the rotary shear system. In real applications, you can use these two together. The feature differences of the two are as follows.

Item	Synchronous Capture axis	E-Cam phase alignment
Correction method	Corrects master axis pulses.	Uses the PR incremental position command to correct the slave axis position.
Digital input (DI)	High-speed DI7 (CAP) only.	Uses DI.ALGN most of the time. Uses Macro #E if using high-speed DI7 (CAP) is required.
Marking position	On the non-compensation motion axis.	On any of the axes (compensation or non-compensation).
Equal space marking	Available.	Available and can be used with the filter.
Random marking	Not available.	When using the high-speed DI7 (CAP) with Macro #E, using the filter is not suggested. Keep the distance between the sensor and cutter within the cutting length per cut.

### 7.3.8 Flying Shear

The flying shear system is a dynamic cutting system of which feeder continues to operate. Therefore, the cutting and feeding axes have to be synchronous during cutting. The synchronous speed duration should allow the cutter to finish cutting and return to the right position to avoid damaging the cutter or materials, as shown in Figure 7.3.8.1. Common applications include cutting machines, filling machines, and labeling machines. Different from rotary shear, the compensation methods using synchronous Capture axis and phase alignment are not applicable to flying shear applications. This avoids machine damage caused by the compensation in the synchronous area.

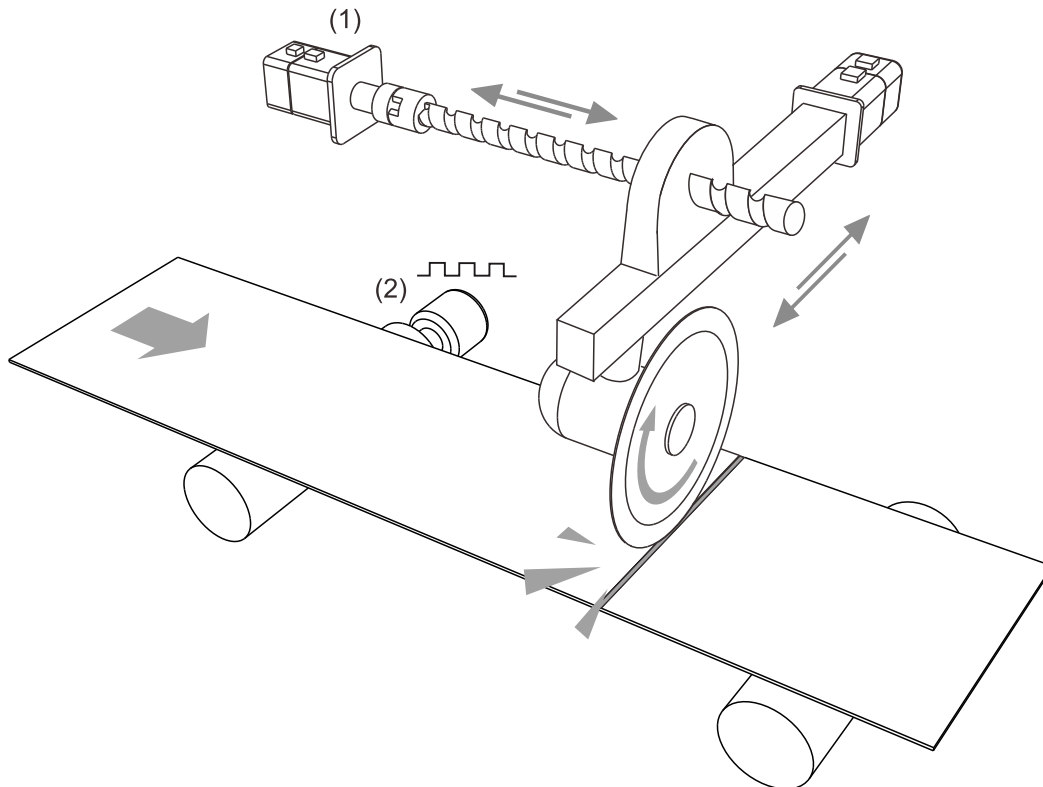

(1) Cutting axis (slave axis); (2) Material feeder (master axis)

Figure 7.3.8.1 Flying shear system

7

The application of flying shear is divided into two types according to the clutch engagement time. The first type is fully engaged. Its E-Cam curve includes the acceleration zone, synchronous speed zone, deceleration zone, and reset zone. The slave axis is completely controlled by the E-Cam system. The second type is partially engaged: the E-Cam operation is triggered by the signal, and the E-Cam curve has no reset zone. After one cycle of E-Cam operation, the clutch disengages and uses the PR command to reset. Then, the E-Cam waits for the next trigger signal. As shown in Figure 7.3.8.2 using a cutting machine as an example, the material feeder is the master axis and the cutting axis is the slave axis. The feeder maintains at a constant speed, and the cutting axis operates according to the E-Cam curve or PR command.

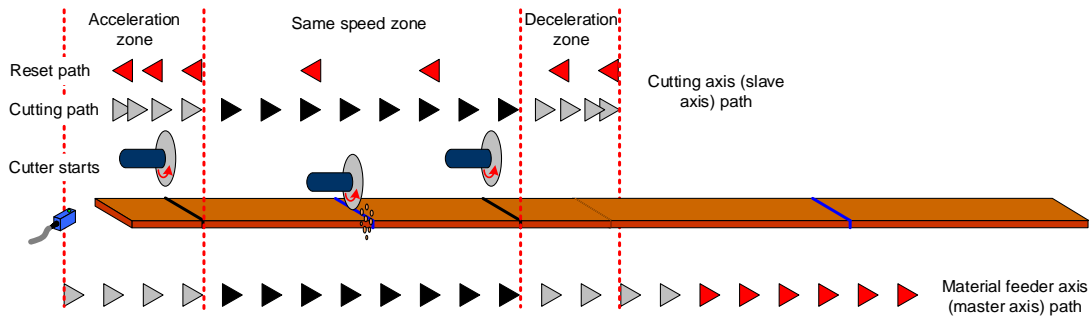

Figure 7.3.8.2 Cutting path and operation cycle of the cutting machine

**Fully engaged**

The fully engaged E-Cam application is suitable for cutting operations without marks. Its E-Cam curve includes the acceleration zone, synchronous speed zone, deceleration zone, and reset zone. The master axis operates at a constant speed. The slave axis operates according to the E-Cam curve and the cutting is complete in the synchronous speed zone. In each cycle, the slave axis starts from the acceleration zone. To avoid wasting materials in the first cycle, set the initial lead pulse before engaged (P5.087). The setting value is the total pulse number of the synchronous speed zone, deceleration zone, and reset zone. If the cutting sensor and material are not aligned during the first cutting, you need to add the offset pulse number of the sensor.

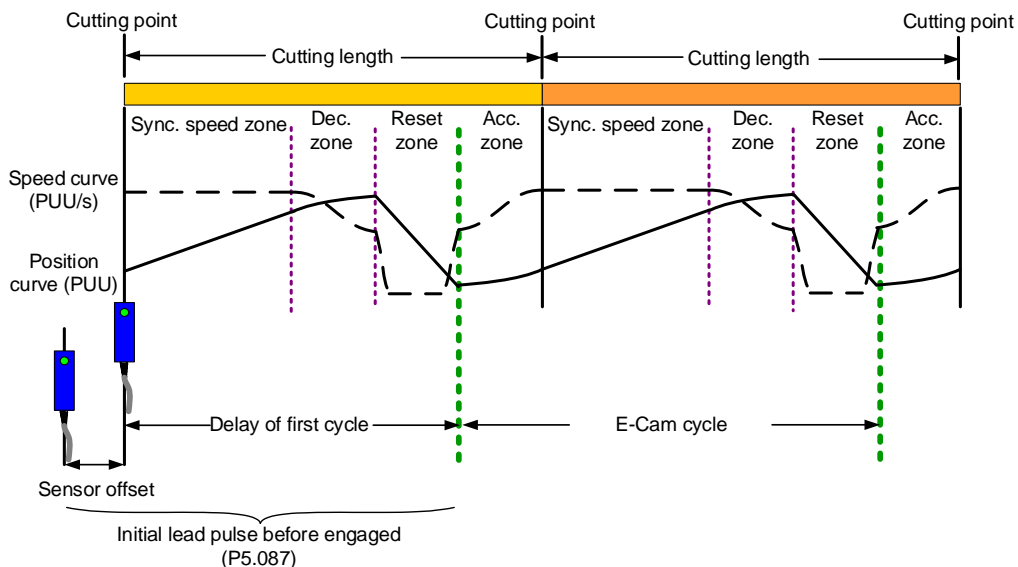
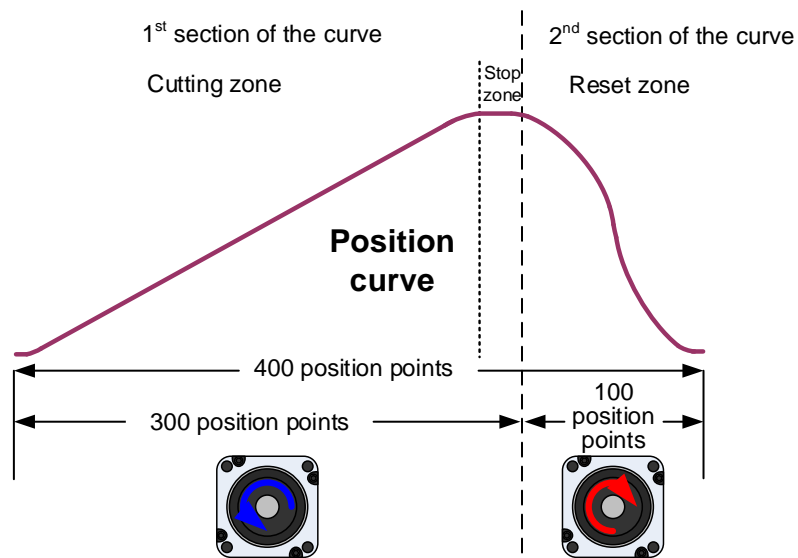

Figure 7.3.8.3 Fully engaged E-Cam cycle of the cutting machine

You can use the “Speed Fitting Creation” in ASDA-Soft to create the E-Cam curve. However, this method can only generate E-Cam curves with single operation direction. You need to create the curves for the cutting zone and reset zone respectively. Then, combine the two curves with the “Manually create a table” function. The operation steps are as follows:

1. Curve planning: segment the cutting zone, stop zone, and reset zone. Because the cutting zone is in the first segment of the curve, there will be more position points plotted in the first segment to ensure the flying shear can complete the cutting in the cutting zone. In the following example, the cutting zone and stop zone are segmented as the first section of the curve with 300 position points. The second section of the curve is the reset zone with 100 position points. So, the curve is composed of 400 position points.



7

- Plan and create the first section of the E-Cam curve: this section has a total of 300 position points including the cutting zone and stop zone, so set the E-Cam segment number N (P5.082) to 300. This example sets the cutting zone to 95% (including acceleration zone of 5%, synchronous speed zone of 85%, and deceleration zone of 5%) which is 285 position points. The stop zone is 5%, which is 15 position points. After setting the required lead distance of the slave axis, click **Create Table**.

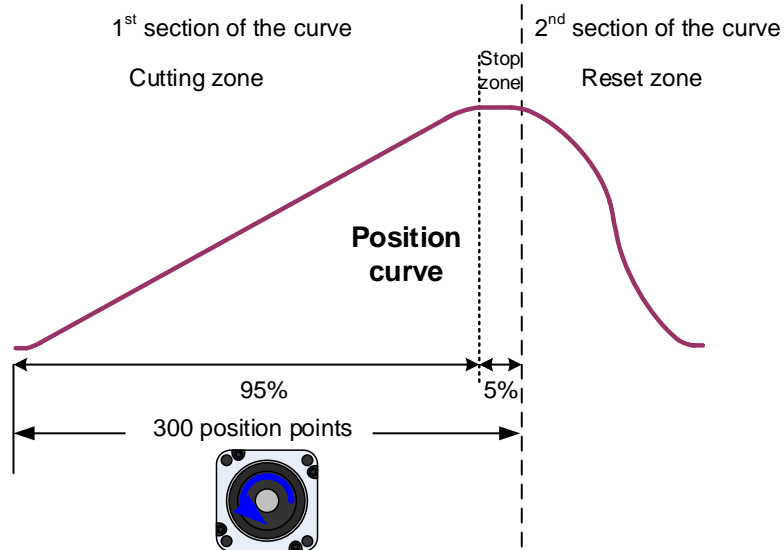

The screenshot shows the E-CAM Editor software interface. The 'Speed Section' parameters are as follows:

- P5.081: Start Position of Data Array: 100
- P5.082: E-Cam Segment No.: 300
- IDLE1: waiting zone: 0 % => 0
- ACC: acceleration zone: 5 % => 15
- CONST: synchronous speed zone: 95% 85 % => 255
- DEC: deceleration zone: 5 % => 15
- IDLE2: stop zone: 5% 5 % => 15
- Distance: 100000 P/U
- S Curve No.: 10

The 'Table' section shows the following data:

B[°]	0	1	2	3	4	5	6	7
Position Y	0	1.2	2.4	3.6	4.8	6	7.2	8.4

The simulation graph shows the position curve (red line) and speed curve (blue line) over a 360-degree range. The position curve starts at 0.000 (P/U) at 0° and reaches 100000.056 (P/U) at 360°. The speed curve starts at 0.000 (P/U) at 0° and reaches 100000.056 (P/U) at 360°. The graph also shows the acceleration curve (green line) and deceleration curve (purple line).

- Export the curve data of the first section: right-click on the table, select **Export points** and a window appears. Select the check box for **All points** and specify the save location, then click **OK** to save.

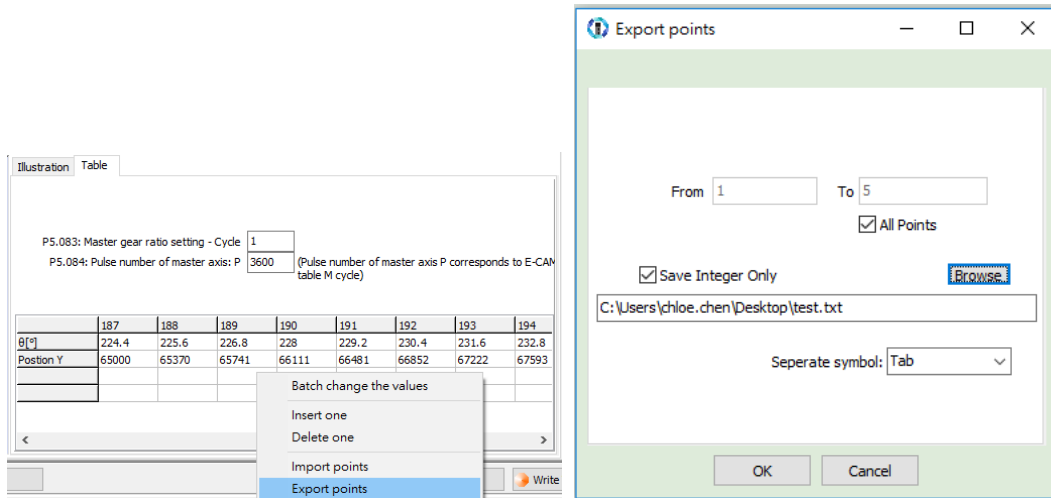

7

- Plan and create the second section of the E-Cam curve: the reset zone has 100 position points in total. You must set the E-Cam segment number N (P5.082) to 100. Since the curves created by this function are all in forward direction, you must first create a curve, and then reverse it to complete the curve for the reset zone.

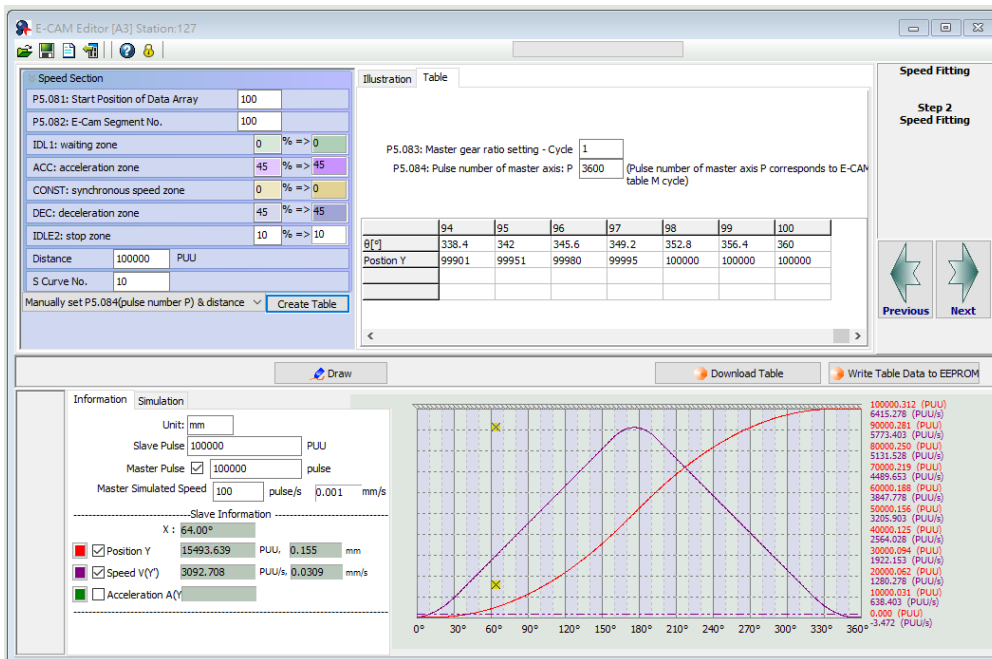



7

After creating the forward direction E-Cam curve, right-click on the table, select **Batch change the values**, and fill in 0 to 200 in the appearing window. Select “\*” (multiplication), fill in “-1”, and select the check box for **Don’t close the window, go on the next operation**, and then the curve direction reverses from forward to backward. Then, select “+” (plus), fill in “100000” for the lead distance of 100,000 PUU, so that the initial value of this curve section smoothly coincides with the final value of the previous curve section. Click **OK**, then click **Draw** to complete the reversed direction of the curve.

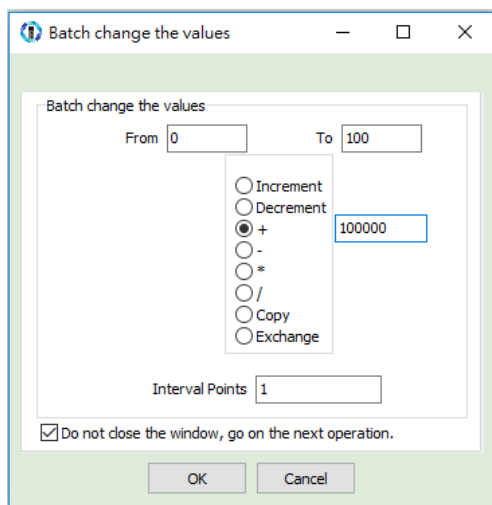
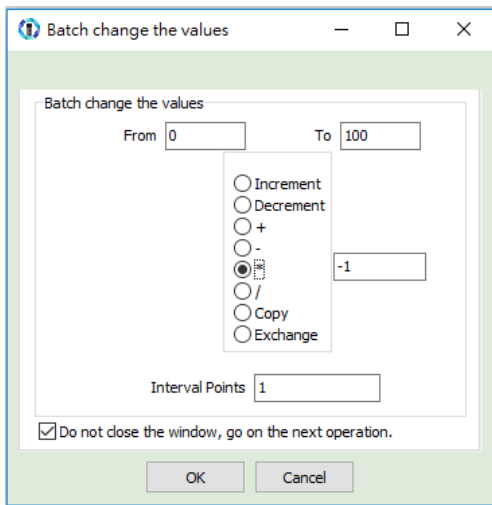
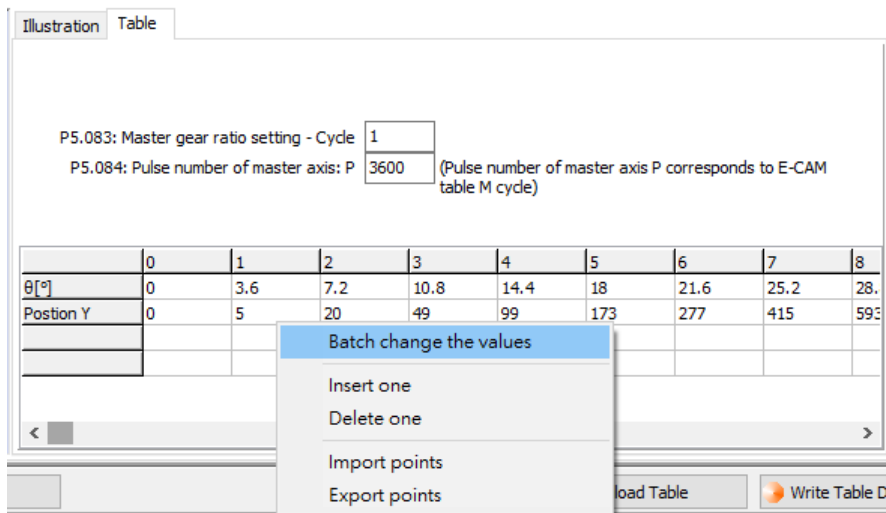

The screenshot shows the E-CAM Editor interface. On the left, the 'Speed Section' parameters are configured: P5.081: Start Position of Data Array (100), P5.082: E-Cam Segment No. (100), IDL1: waiting zone (0), ACC: acceleration zone (45), CONST: synchronous speed zone (0), DEC: deceleration zone (45), IDLE2: stop zone (10), Distance (100000 PUU), and S Curve No. (10). A table below these parameters shows the relationship between angle and position Y.

θ[°]	0	1	2	3	4	5	6	7	8
Position Y	100000	99995	99980	99951	99901	99827	99723	99585	99415

On the right, the 'Speed Fitting' section is set to 'Step 2 Speed Fitting'. Below the table is a graph showing speed and position curves over a 360-degree range. The graph includes a legend with values for Position Y and Speed V(Y) at various points.

7

- Export the curve data of the second section: right-click on the table, select **Export points** and a window appears. Select the check box for **All points** and specify the save location, and then click **OK** to save.

This screenshot shows the table from the previous screenshot with a context menu open over it. The menu options include 'Batch change the values', 'Insert one', 'Delete one', 'Import points', and 'Export points', which is currently selected.

The 'Export points' dialog box is shown with the following settings: 'From' 1, 'To' 5, 'All Points' checked, 'Save Integer Only' checked, the file path 'C:\Users\chloe.chen\Desktop\test2.txt', and 'Seperate symbol' set to 'Tab'. 'OK' and 'Cancel' buttons are at the bottom.

7

- Combine E-Cam curves: use "Manually create a table". The E-cam curve has a total of 400 position points, so you need to set the E-Cam segment number N (P5.082) to 400. Click **Create Table** and a table of 400 position points is generated. Right-click on the table, select **Import points**, fill in "0" to "300" in the pop-up window, select the first section of the curve, and then click **OK**. Follow the same steps as previous, but fill in "301" to "400" in the pop-up window, select the second section of the curve, and then click **Draw** to complete the E-Cam curve of the fully engaged mode.

The screenshot shows a software interface with a table and two 'Import points' dialog boxes. The table has columns 0-13 and rows for theta [°] and Position Y. The first dialog box shows 'From 0 To 300' and the second shows 'From 301 To 400'. Both dialog boxes have a 'Browse' button and a file path 'C:\Users\chloe.chen\Desktop\test.txt'.

	0	1	2	3	4	5	6	7	8	9	10	11	12	13
θ[°]	0	0.9	1.8	2.7	3.6	4.5	5.4	6.3	7.2	8.1	9	9.9	10.8	11.7
Position Y	1	2	3	4	5	6	7	8	9	10	11	12	13	14

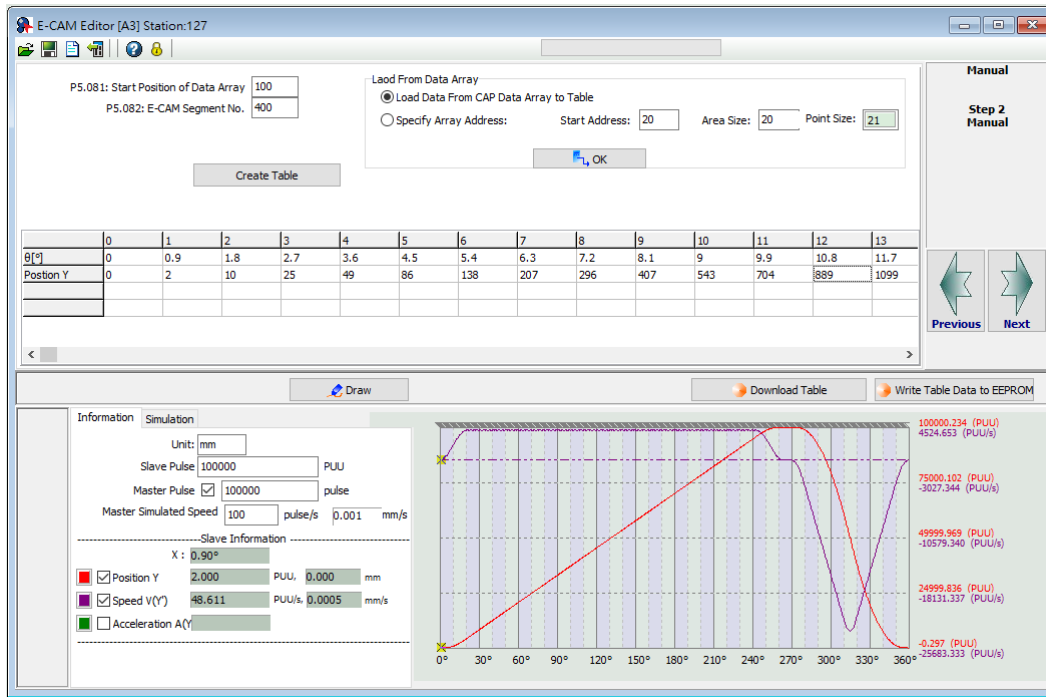

The operation of the fully engaged mode is based on the E-Cam curve. The E-Cam curve is more complex and more difficult to create, so if the cutting length changes, you can only modify the cutting length by setting the pre-engaged pulse number for each cycle (P5.092) or adjust the E-Cam gear ratio (P5.084 / P5.083) and curve scaling (P5.019).

- Cutting length is greater than the E-Cam curve operating length  
 Select to enter cyclic mode after disengaging (P5.088.U = 4) and set the pre-engaged pulse number for each cycle (P5.092). When the E-Cam enters the pre-engaged status, the material feeder continues operating, but the cutting axis stops. The cutting axis resumes operation until the pre-engaged pulse number for each cycle is met. The greater the pre-engaged pulse number for each cycle, the longer the cutting length.

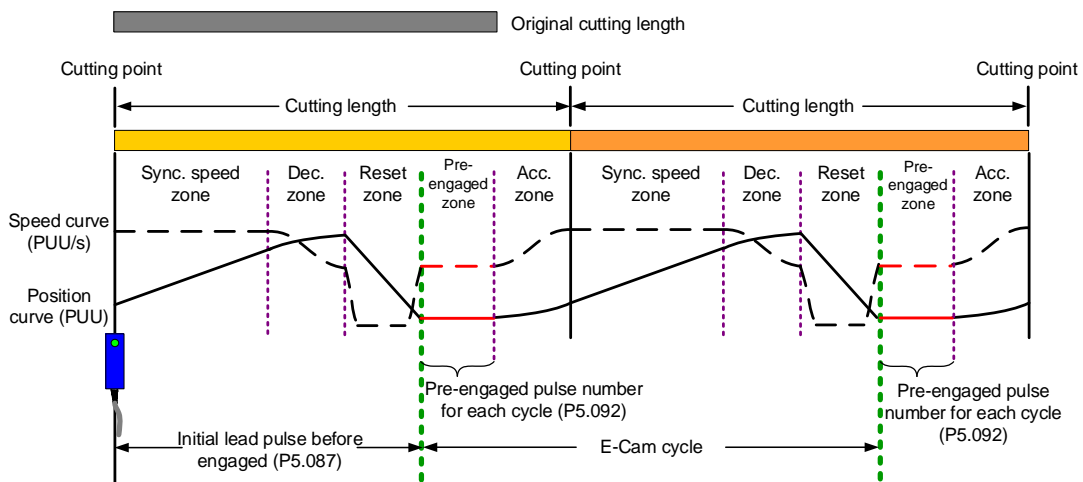

7

- Cutting length is less than the E-Cam curve operating length

Reduce the E-Cam master axis pulse number and slave axis moving distance proportionally. For example, if you reduce the master axis pulse number for each cycle (P5.084 / P5.083) to 0.8 times of the original, the moving distance of the slave axis should also reduce 0.8 times. You can use the E-Cam curve scaling (P5.019) to reduce the setting by 0.8 times to shorten the cutting length. However, this method also reduces the synchronous speed zone, so make sure that the cutting action can be completed in the synchronous speed zone. This method is not recommended for applications when the cutting length is greater than the E-Cam curve operating length. Because when you increase the moving distance of the slave axis, the machine may not have sufficient distance to complete the slave axis motion which can lead to collision.

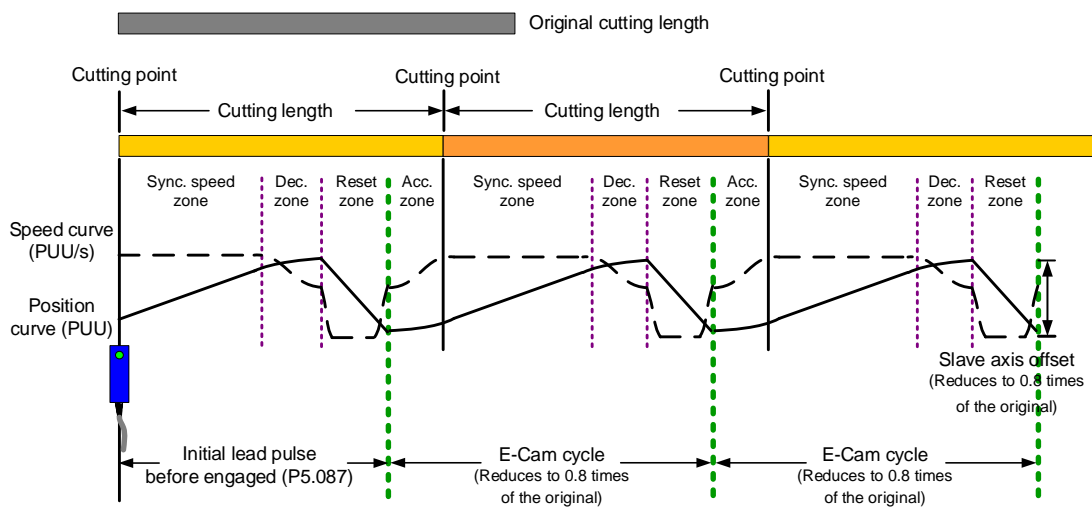

**Partially engaged**

This is applicable for cutting operations with or without marks. For the cutting operation with marks, use the Capture function to have the E-Cam engaged. For the cutting without marks, use the Compare function to generate virtual marks for the Capture function to capture the position data. The E-Cam curve includes the acceleration zone, synchronous speed zone, and deceleration zone. After the E-Cam curve (acceleration, synchronous speed, deceleration zones) is executed, the clutch disengages. The reset zone is completed with a PR command and then it waits for the next trigger signal to have the clutch engaged. With this method, you can create an E-Cam curve with a larger synchronous speed zone based on the maximum moving distance of the cutter. This is suitable for applications with the cutting length smaller than the waiting zone. For applications with the cutting length greater than the maximum moving distance of the cutter, disengage the E-Cam and have the material feeder continue to operate, and then the E-Cam re-engages when the servo receives the trigger signal.

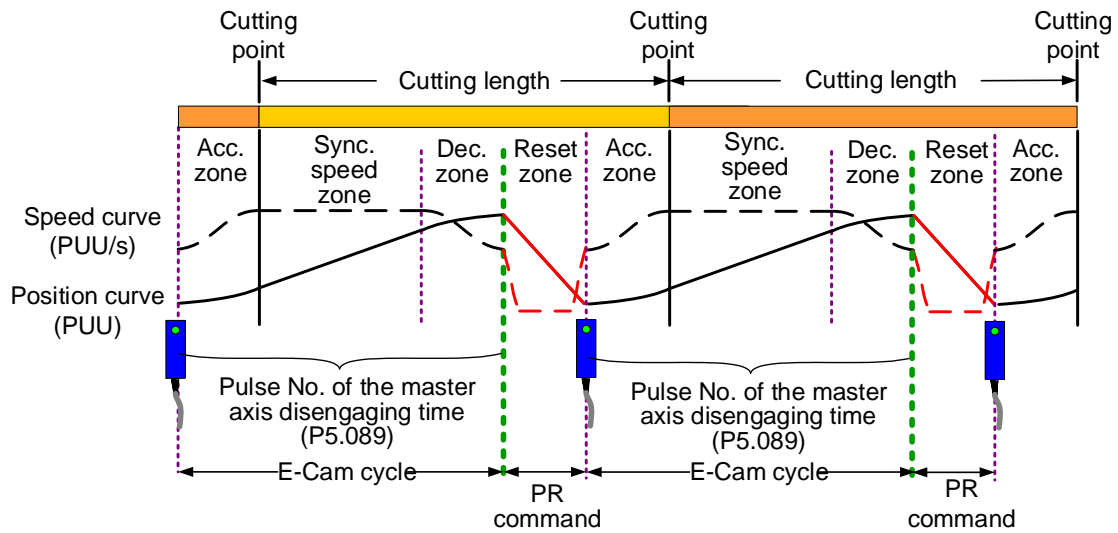

Figure 7.3.8.4 E-Cam cycle of the partially engaged cutting machine

# 7

After creating an E-Cam curve based on the maximum moving distance of the cutting axis, set the master pulse number of disengaging time (P5.089) according to the cutting length. After the disengaging pulse number is reached or the cutting complete signal is received, the clutch disengages and continues with a zero-speed PR speed command to stop the cutter. Then, it uses another PR position command to return the cutter to the initial position, as shown in Figure 7.3.8.5. The setting methods are as follows:

1. Master axis signal source: set P5.088.Y to 0; it means the source of the master axis is the capturing axis. In the Capture function, this capturing axis refers to the setting of P5.039.Y for the signal source of the master axis.
2. Engagement condition: set P5.088.Z to 2; it means the clutch engages as soon as the first data is captured and the signal is input through DI7 to the servo drive.
3. Disengagement condition: set P5.088.U to E; it means the clutch disengages when the master axis pulse number reaches the pulse number set in P5.089, the slave axis decelerates to stop, and the E-Cam function is disabled.
4. To set the subsequent PR procedure after the clutch disengages, set the PR number to be executed in P5.088.BA in hexadecimal.
5. Set the PR procedures:

Procedure 1: set the PR commands for execution when the cutting machine is activated. PR#1 confirms the Capture function is disabled. PR#2 confirms the E-Cam function is disabled. PR#3 jumps to PR#C. PR#C sets the capturing amount to 1. PR#D enables the Capture function. PR#E enables the E-Cam function.

Procedure 2: set the subsequent PR commands after the clutch disengages. PR#A sets the zero-speed command to stop the cutting axis. PR#B sets the position command to return the cutting axis to the initial position.

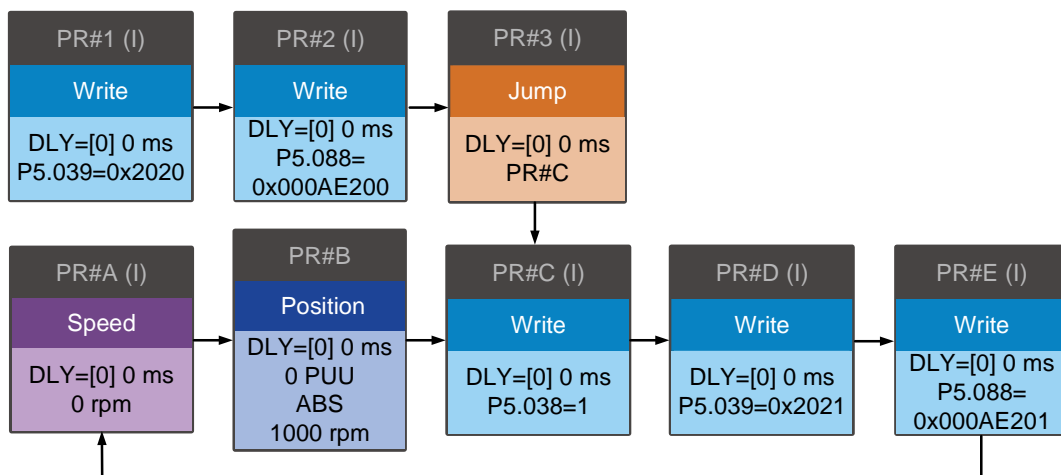

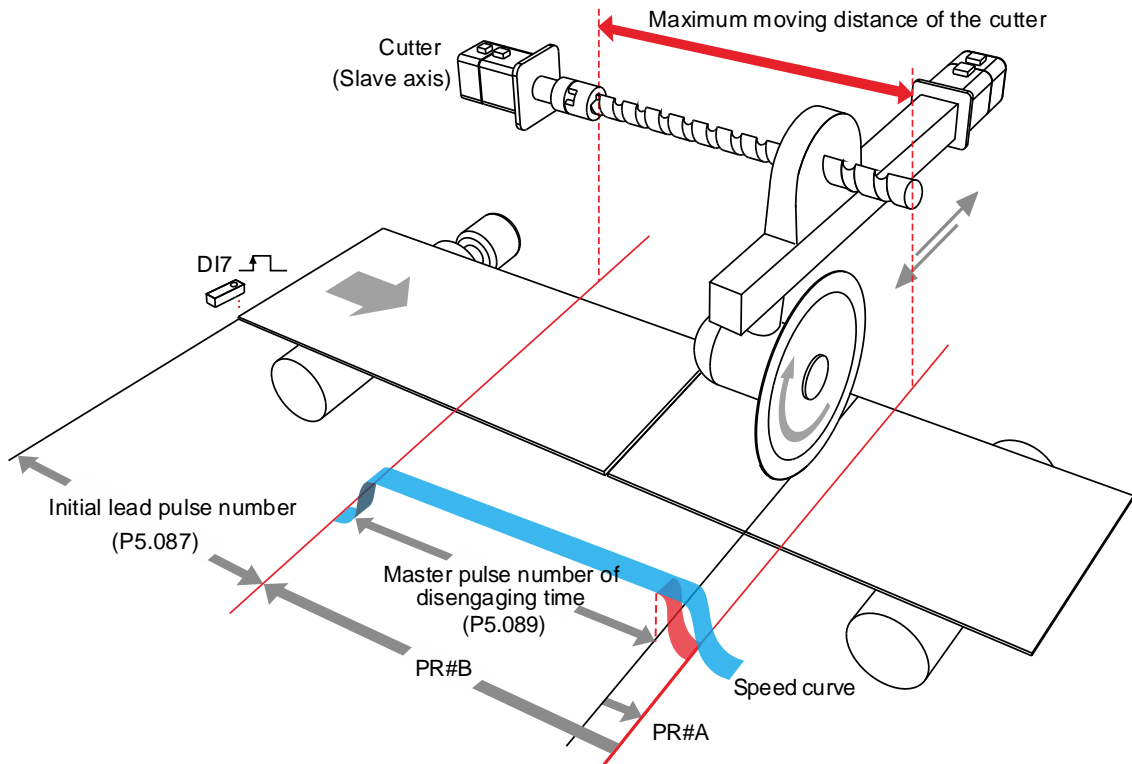

Figure 7.3.8.5 Operation of partially engaged cutting axis



### 7.3.9 Macro

In real applications, the macro commands cater to different needs during E-Cam operation, such as the requirements for stopping and resuming the operation after an alarm occurs, the phase alignment at the initial operation stage, or phase modification and pausing the cycle during operation. You can use the following macros to complete the tasks. Use P5.097 to enable the macro. Enter values to P5.093 - P5.096 based on the macro requirements.

Macro	Function	Application requirement
Macro #5	Sets the pulse number for the master axis gear ratio (P5.084) and the pulse number for disengagement (P5.089) as the same.	The cams disengage after one cycle.
Macro #8	When the clutch engages, the E-Cam curve scaling (P5.019) takes effect one time.	Prompt change in scaling.
Macro #C	When the clutch engages, sets the master axis pulse phase when the motor remains unmoved.	Precise control of the clutch engagement position.
Macro #D	When the slave axis position is not in the corresponding E-Cam curve, calculates the position correction amount and writes this amount to the PR incremental position command.	Slave axis position offset correction for E-Cam cycles.
Macro #E	Uses high-speed DI7 to perform E-Cam phase alignment, calculates the compensation amount, and writes this amount to the PR incremental position command.	Non-cyclic marking function.
Macro #F	When the master axis stops and the clutch disengages, moves the slave axis to the specified position and then back to the original position.	Evacuating the damaged material due to miscutting.
Macro #10	Carries on the operation after the slave axis stops for one cycle.	Empty pack prevention mechanism.

**Macro #C - change the engagement position and operate in forward direction until the disengagement condition is met**

When the clutch is engaged, this macro immediately changes the master axis position and automatically calculates the remaining pulse number in the cycle. When the E-Cam cycle is complete, the clutch disengages based on the set disengagement condition (P5.088.U).

This macro can be used for setting the initial engagement position for the master axis and you can select any of the master axis position to engage. The precision level is higher when you use Macro #C than using P5.085 to select the section from the E-Cam table for engagement. When using this macro, have the master axis stay stationary. Wait for the macro to complete before operating the master axis. The operation is shown in Figure 7.3.9.1.

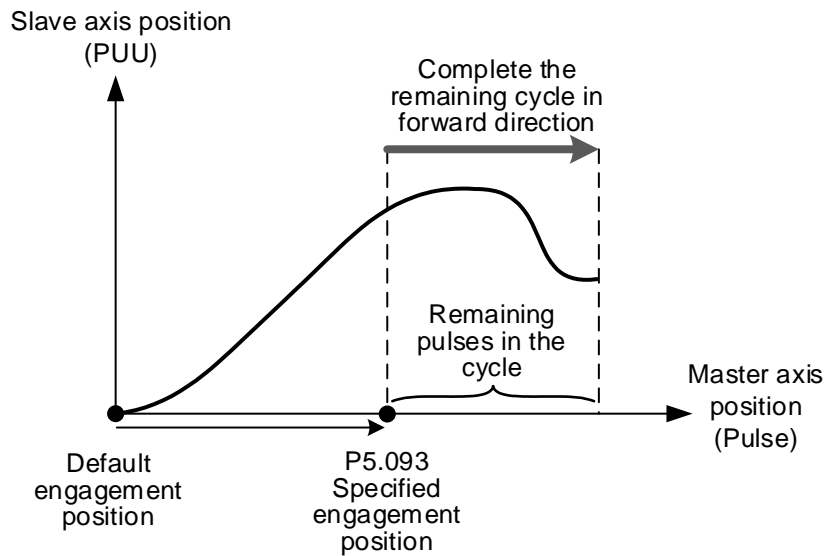

Figure 7.3.9.1 Macro #C operation

Setting steps:

1. The E-Cams engage and the master axis stops.
2. Set the disengagement condition (P5.088.U).
3. Set the engagement position: use P5.093 to write the master axis engagement position (pulse) in hexadecimal and use monitoring variable 062 (3Eh) to monitor the current master axis position. The range for the new specified engagement master axis position is:

$$0 \leq \text{P5.093(Pulse)} < \frac{\text{P5.084}}{\text{P5.083}}$$

4. Enable Macro #C: set P5.097 = 0x000C to enable Macro #C. Read P5.097 and if it returns 0x100C, it means the macro execution is successful. If any of the following failure codes shows, modify the setting according to the description.

Failure code	Description
0xF0C1	When this macro command is executed, the clutch is not in the engaged status.
0xF0C2	The engagement position specified in P5.093 exceeds the range (must be $\geq 0$ ).
0xF0C3	The engagement position specified in P5.093 exceeds the range (must be $< \frac{P5.084}{P5.083}$ ).

### Macro #D - calculate the deviation between the current slave axis position and rotary axis position for PR positioning

When the slave axis position is not at the E-Cam curve corresponding position, this macro finds the slave axis position corresponding to the master axis position. Next, it calculates the deviation between this position and the current motor position, and writes the deviation to the PR incremental position command. You can trigger the specified PR and move the motor of the slave axis to the position corresponding to the master axis position. This macro is suitable for the cyclic motion which starts from the same point. In other words, the mechanical part returns to the start point each cycle; and the slave axis moving distance is the same as the rotary axis position scale. You can monitor the rotary axis position in PUU with monitoring variable 091 (5Bh). The operation is shown in Figure 7.3.9.2.

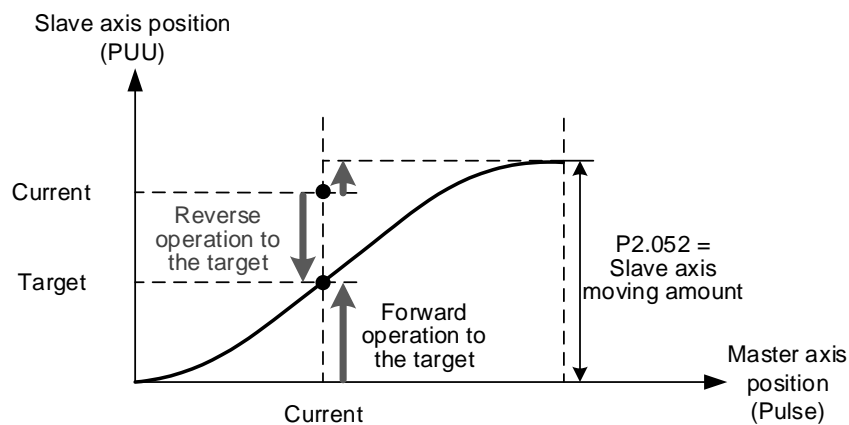
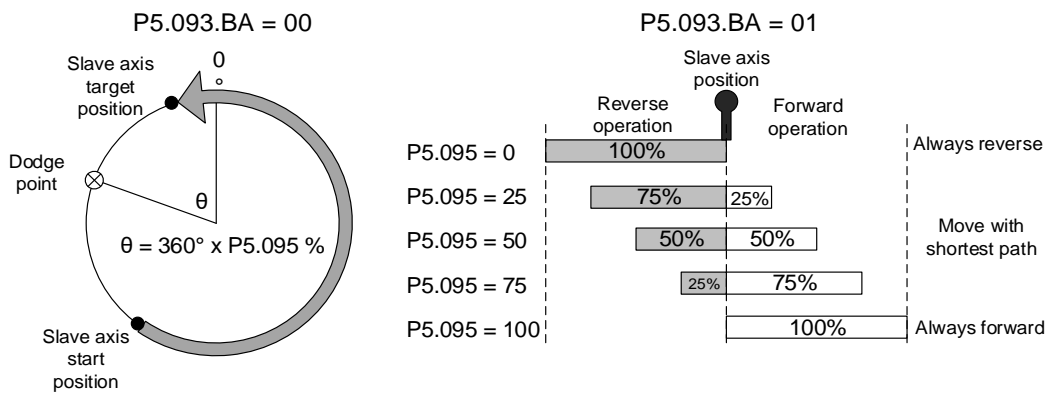

Figure 7.3.9.2 Macro #D operation

Setting steps:

1. Set P5.088.X Bit 1 to 1 to keep the clutch engaged when Servo Off and engage the E-Cam.
2. Set the rotary axis position scale to equal the moving distance of the slave axis per cycle (P2.052 = slave axis moving distance ECAM\_H).
3. Set the E-Cam scaling to 1 (P5.019 = 1).

4. Set the initial engagement position: align the start point of 0 degree in the E-Cam curve table with the origin of the rotary axis position.
5. Set the PR number to save the deviation: specify PR#1 - 99 in hexadecimal.  
Set P5.093.YX = 0x01 - 0x63, and set this PR as an incremental position command.
6. Select the direction control type: set P5.093.BA = 00 to use the dodge point for controlling the forward and reverse directions. Set P5.093.BA = 01 to use the allowable forward rate for controlling the forward and reverse directions.
7. Set the reverse inhibit function: set P5.093.CD = 0 to disable the reverse inhibit function.  
Set P5.093.CD = 1 to enable the reverse inhibit function.
8. Set the dodge point or allowable forward rate: if using the dodge point for direction control, set P5.095 to 0 - 100% for the dodge position. If using the allowable forward rate for direction control, set P5.095 to 0 - 100% as the allowable forward rate. Refer to the following figure.



9. Enable Macro #D: set P5.097 = 0x000D to enable Macro #D. Read P5.097 and if it returns 0x100D, it means the macro execution is successful. If any of the following failure codes shows, modify the setting according to the description.

Failure code	Description
0xF0D1	When this macro command is executed, the clutch is not in the engaged status.
0xF0D2	PR number specified by P5.093.YX exceeds the range (0x01 - 0x63).
0xF0D3	P5.095 the dodge point or allowable forward rate exceeds the range (0 - 100%).
0xF0D5	Position correction value does not exist. This macro command might be triggered twice.
0xF0D6	E-Cam did not remain engaged when servo is off, so when servo switches to the on state again, E-Cam is not engaged.
0xF0D7	Slave axis moving distance does not equal the rotary axis position scale (ECAM_H $\neq$ P2.052).
0xF0D8	E-Cam curve scaling does not equal 1 (P5.019 $\neq$ 1).
0xF0D9	P5.093.BA forward / reverse direction setting exceeds the range (00 - 01).
0xF0DA	P5.093.DC reverse inhibit setting exceeds the range (00 - 01).
0xF0DB	The reverse inhibit function has failed. Do not use macro commands #D and #10 consecutively.

### Macro #E - PR positioning using E-Cam correction amount

When the clutch engages, this macro sets the master axis engagement position (pulse) and calculates the required correction amount for the slave axis to complete positioning for one time. Next, it writes this correction amount to the PR incremental position command to execute. You can trigger this PR command to have the slave axis operate to the corresponding target position at the proper time. In actual applications, you can connect the external sensor to the servo drive DI, and use an event trigger to enable Macro #E. Then, the macro calculates the correction amount and writes this value to the specified PR program. This macro is suitable for applications with random markings. The operation is shown in Figure 7.3.9.3.

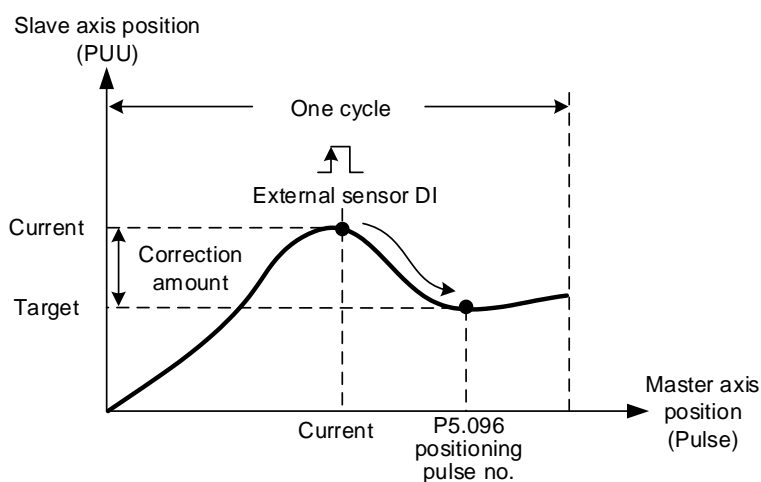

Figure 7.3.9.3 Macro #E operation

Setting steps:

1. Engage the clutch.
2. Set the PR number to save the correction amount: specify PR#1 - 99 in hexadecimal. Set P5.093.YX = 0x01 - 0x63, and set this PR as an incremental position command.
3. Set the maximum correction rate: specify the maximum correction rate of 0 - 100% in hexadecimal. When P5.093.UZ = 0x00 - 0x64%, it limits the correctable range to avoid over-correction per time and causing machine vibration.
4. Set the PR trigger timing: set P5.093.A to 1 to immediately trigger the PR command for correction. Set P5.093.A to 0 to manually trigger the PR command.
5. Set the mark position: set P5.093.B to 0 to mark on other motion axis and the following mark positions are not changed when positioning. Set P5.093.B to 1 to mark on the motion axis for compensation, but this changes the following mark positions when positioning.
6. Set the triggering method: set P5.093.C to 0 to use the general DI with event triggering. Set P5.093.C to 1 to use the high speed DI7 with Capture function as the triggering method; meanwhile, set the pulse source of the master axis (P5.088.Y = 0) as the Capture axis. When the last position data is captured, execute PR#50 (P5.039.X Bit 3 = 1) to perform the compensation. This is suitable for high precision applications.

7. Set the compensation for the DI time delay: set P5.094 as -25000 to 25000 (μs) to compensate the delay time for the sensor and the signal transmission.
8. Set the allowable forward rate: set P5.095 to 0 - 100% to specify the allowable forward rotation rate.



9. Set the positioning pulse number: use P5.096 to set the pulse number (position) of the master axis for positioning. The setting range is as follows:

$$0 \leq P5.096(\text{Pulse}) < \frac{P5.084}{P5.083}$$

10. Enable Macro #E: set P5.097 = 0x000E to enable Macro #E. Read P5.097 and if it returns 0x100E, it means the macro execution is successful. If any of the following failure codes shows, modify the setting according to the description.

Failure code	Description
0xF0E1	When this macro command is executed, the clutch is not in the engaged status.
0xF0E2	PR number specified by P5.093.YX exceeds the range (0x01 - 0x63).
0xF0E3	P5.093.UZ maximum correctable rate exceeds the range (0x00 - 0x64%).
0xF0E4	P5.094 DI delay time compensation exceeds the range (-25000 to 25000 μs).
0xF0E5	P5.095 allowable forward rate exceeds the range (0 - 100%).
0xF0E6	P5.096 pulse number (position) of the master axis for positioning exceeds the range ( $0 \leq P5.096 < \frac{P5.084}{P5.083}$ ).
0xF0E7	P5.093 setting value exceeds the range (0x0000 - 0x0111).
0xF0E8	When using DI7 with the Capture function for triggering (P5.093.C = 1), set the Capture axis as the source pulse of the master axis (P5.088.Y = 0).
0xF0E9	When using DI7 with the Capture function for triggering (P5.093.C = 1), execute PR#50 (P5.039.X Bit 3 = 1) for compensation after the last data is captured.

**Macro #F - use the deviation between the current slave axis position and the target position for PR positioning**

7 When the master axis stops but the E-Cams remain engaged, this macro can move the slave axis to the specified position and then return it to the original position. The specified position is set with the master axis pulse number. After Macro #F is triggered, the servo calculates the required moving amount for the slave axis to move to the specified position and writes this moving amount to the two PR incremental position commands (onward and return trips). Trigger the onward trip PR command, and the slave axis moves to the target position. Trigger the return PR command, and the slave axis returns to the original position. This macro is suitable for applications that require moving the slave axis while the system or the master axis is stopped. The operation is shown in Figure 7.3.9.4.

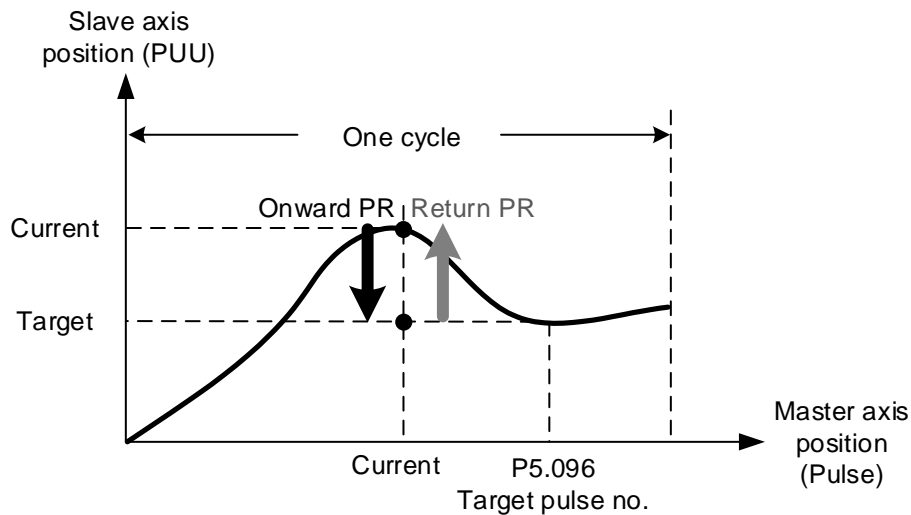
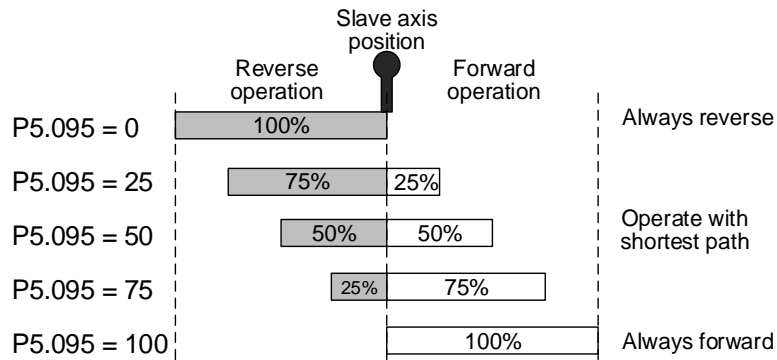

Figure 7.3.9.4 Macro #F operation

Setting steps:

1. The master axis stops and the clutch is engaged.
2. Set the onward and return trip PR numbers: specify any of the PR from PR#1 - 99 in hexadecimal as the onward trip PR command. Set P5.093.YX = 0x01 - 0x63 and set this PR as the incremental position command. Set any of the PR from PR#1 - 99 as the return trip PR command. Set P5.093.UZ = 0x01 - 0x63 and set this PR as the incremental position command. Do not use the same PR number at the same time.

- Set the allowable forward rate: set P5.095 to 0 - 100% to specify the allowable forward rotation rate.



- Set the target pulse number: use P5.096 to specify the master axis pulse number of the target position, which range is as follows:

$$0 \leq P5.096(\text{Pulse}) < \frac{P5.084}{P5.083}$$

- Enable Macro #F: set P5.097 = 0x000F to enable Macro #F. Read P5.097 and if it returns 0x100F, it means the macro execution is successful. If any of the following failure codes shows, modify the setting according to the description.

Failure code	Description
0xF0F1	When this macro command is executed, the clutch is not in the engaged status.
0xF0F2	PR number of onward trip specified by P5.093.YX exceeds the range (0x01 - 0x63).
0xF0F3	PR number of return trip specified by P5.093.UZ exceeds the range (0x01 - 0x63).
0xF0F5	P5.095 allowable forward rate exceeds the range (0 - 100%).
0xF0F6	P5.096 master axis pulse number of the target position exceeds the range $(0 \leq P5.096 < \frac{P5.084}{P5.083})$ .



7

**Macro #10 - the slave axis immediately pauses for one cycle**

When the clutch is engaged and the slave axis operates in forward direction, this macro can stop one cycle of the slave axis operation and then the operation resumes. To stop for multiple cycles, consecutively trigger Macro #10 for a number of times. The servo drive records the number of times Macro #10 is triggered and the slave axis will stop for the number of cycles accordingly. When using this macro, use P1.022 PR special filter and set P1.022.YX acceleration time limit (the required time for the motor to accelerate from 0 to 3000 rpm, which range is 10 - 1270 ms). If the acceleration or deceleration time is shorter than the acceleration time limit, then the filter takes effect and smooths the acceleration or deceleration process, preventing the command from changing too drastically and machine vibration. The following error caused by the smooth command will be compensated after the command changes become moderate, so the final position does not deviate. This macro is usually used for the empty pack prevention function on the packing machine. The operation is shown in Figure 7.3.9.5.

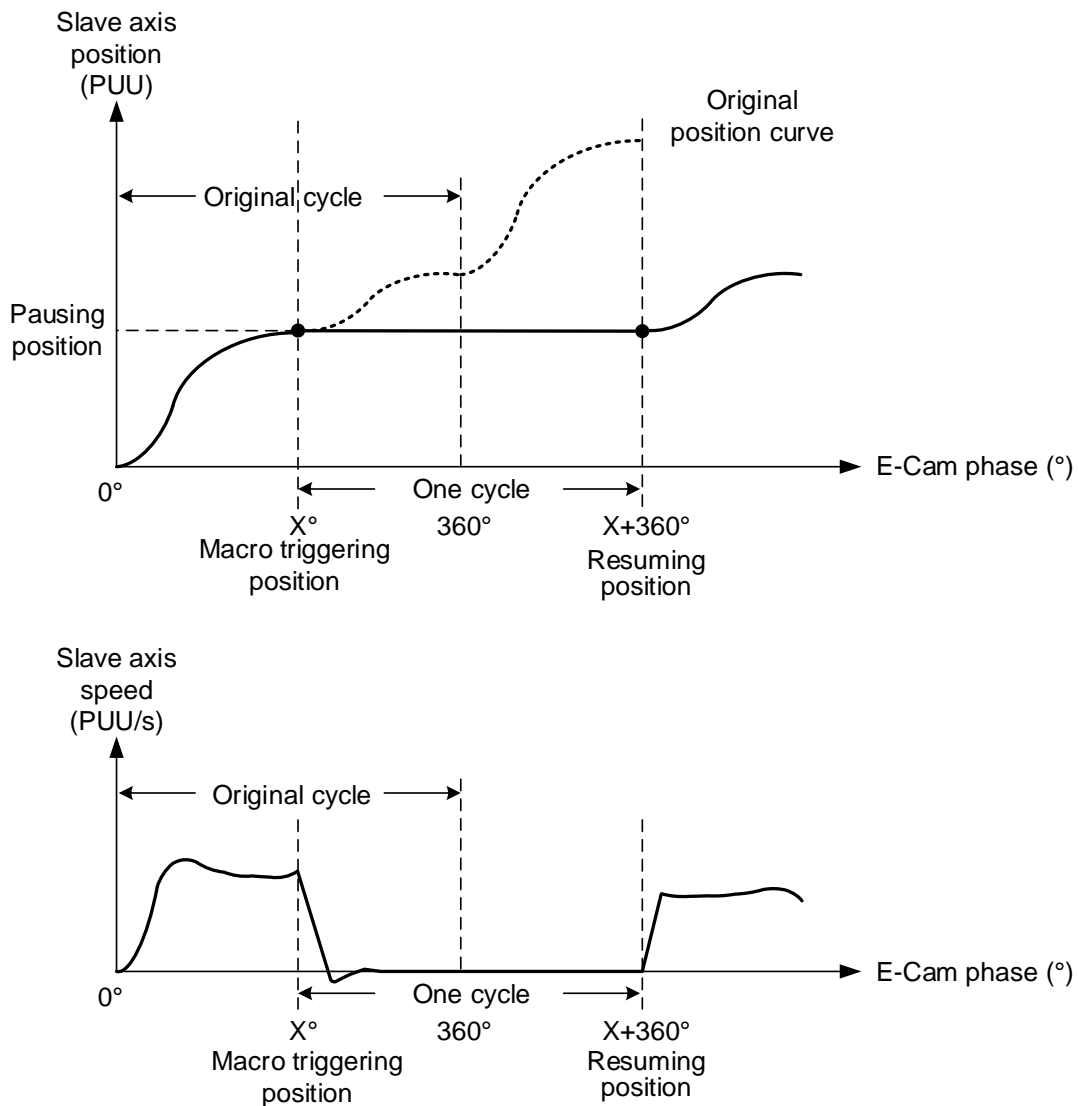

Figure 7.3.9.5 Macro #10 operation

Setting steps:

1. Engage the clutch.
2. Set P1.022.YX the acceleration time limit. If the reverse inhibit is required, set P1.022.U.
3. Enable Macro #10: set P5.097 = 0x0010 to enable Macro #10. Read P5.097 and if it returns 0x1010, it means the macro execution is successful. If any of the following failure codes shows, modify the setting according to the description.

Failure code	Description
0xF101	When this macro command is executed, the clutch is not in the engaged status.
0xF102	Set P5.093 to 0.
0xF103	The slave axis must operate in forward direction. Check the E-Cam curve and P5.019 E-Cam curve scaling.
0xF104	Accumulated pause distance exceeds $2^{31}$ . Do not execute this macro command consecutively.

Note: this function is accumulative. If the command is triggered for N times consecutively, it pauses the E-Cam for N cycles. Note that the accumulated pause distance cannot exceed the range.

When the pause cycle is complete, the slave axis continues to operate and the accumulated pause distance is cleared to 0.

### 7.3.10 Auxiliary function

#### Following error compensation

7 There are two factors causing the following error. The first is the servo error, which is generated by the position loop and can be eliminated by the position integral compensation (P2.053).

The second is the command processing delay, which is the delay caused by the filter or command. For the general point-to-point motion, the servo waits for the positioning complete signal and then proceeds to the next command. This does not generate too much following error and affect the motion. However, for E-Cam applications, you must reduce the following error, or the E-Cam phase can deviate, reducing the machining precision.

To enable the following error compensation function, set P1.036 to 1. Meanwhile, set P1.008 (Position command smoothing constant) to 0 ms. Enable the position command moving filter (P1.068) and set the value to less than 10 ms. Set the position integral compensation (P2.053) to less than 50. If you are not satisfied with the performance in the acceleration or deceleration stage, adjust the command response gain (P2.089) to reduce the following error. To have better performance in the synchronous speed zone, set the additional compensation time (P1.017) to compensate the deviation. The formula is as follows.

$$\text{Compensation distance} = \text{P1.017 (Additional compensation time)} \times \text{current motor speed}$$

Excluding the following error caused by the machine, if the error is proportional to the speed (for example: 100 rpm with an error of 0.01%; 1000 rpm with an error of 0.1%), it could be caused by the electrical delay. In this case, use P1.018 and P1.021 to compensate the E-Cam phase. The compensation mechanism is as follows.

$$\text{Compensation amount (pulse)} = \text{P1.018 (Compensation time)} \times [\text{Master axis pulse frequency (Kpps)} - \text{P1.021 (Minimum frequency of pulse compensation for the E-Cam master axis)}]$$

The master axis pulse frequency can be monitored with monitoring variable 060 (3Ch), which value has to be greater than the minimum compensation frequency.

**Virtual master axis**

During E-Cam operation, if there is a phase lead or phase lag in the slave axis, use the virtual master axis to correct the cam phase. Virtual master axis operation is as shown in Figure 7.3.10.1.

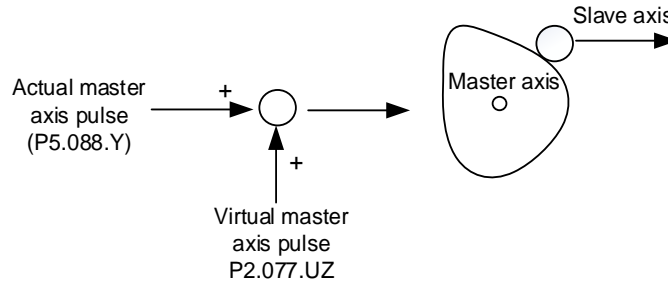

Figure 7.3.10.1 Virtual master axis operation

Use P2.077 to set the virtual master axis function.

P2.077.X can mask the actual master axis pulses and determine how the virtual master axis pulses are generated, as shown in the following table.

X	Function	Actual master axis pulse	Virtual master axis pulse	Description
0	Function disabled	Received	Disabled	Slave axis is driven by the actual master axis pulse.
1	Master axis pulse masked	Masked		Slave axis stops operating, but the masked master axis pulse continues to be stored in the internal variable.
2	Continuous forward running		Enabled	Command source is the virtual pulse frequency (unit: Kpps) set in P2.077.UZ. This function continues to operate. To stop the virtual pulse, set X to 1.
3	Continuous reverse running			Command source is the virtual pulse number (unit: pulse) set in P2.077.UZ. This function only refers to the pulse number set in P2.077.UZ.
4	Forward JOG			
5	Reverse JOG			
6 - 8	Reserved	-	-	-
9	Master axis pulse received	Received	Disabled	Slave axis is driven by the actual master axis pulse and the master axis pulse continues to be stored in the internal variable.
A	Continuous forward running		Enabled	Command source is the frequency transmitted by the actual master axis (P5.088.Y) plus the virtual pulse frequency (unit: Kpps) set in P2.077.UZ. This function continues to operate. To stop the virtual pulse, set X to 9.
B	Continuous reverse running			Command source is the pulse transmitted by the actual master axis (P5.088.Y) plus the virtual pulse number (unit: pulse) set in P2.077.UZ. This function is often used for dynamic adjustment.
C	Forward JOG			
D	Reverse JOG			

P2.077.Y sets whether to write the pulse number of the virtual master axis to P5.087 (Initial lead pulse before engaged).

- When the setting of P2.077.Y is changed from 0 to 1, the pulse number of the virtual master axis is written to P5.087.
- When the setting of P2.077.Y is changed from 0 to 2, the pulse number of the virtual master axis is written to P5.087 and stored in EEPROM as non-volatile data.
- When the setting of P2.077.Y is changed from 0 to 7, the pulse number of the virtual master axis plus the pulse number of one cycle is written to P5.087 and stored in EEPROM as non-volatile data. The value written to P5.087 has to be positive. When the pulse number of the virtual master axis is negative, the system automatically makes it a positive number by adding the master axis pulses of one or multiple cycles and then writes this value to P5.087.

P2.077.UZ sets the virtual master pulse number in hexadecimal. If you set the master axis to operate in forward or reverse direction, the unit is Kpps. If you set the master axis to jog in forward or reverse direction, the unit is pulse.

7

### 7.3.11 Horizontal packing machine applications

Horizontal packing machine mainly uses the rotary shear applications and phase compensation in the E-Cam system to have the cutter cut the wrap at the right spot. The rotary shear system can generate suitable E-Cam curves based on the initial mark position, cutter width, and cutting length and time so it can cut precisely. With the auxiliary functions such as empty pack prevention and miscutting prevention, you can avoid material waste or machine damage caused by miscutting. The phase compensation function is to deal with issues such as inadequate tension adjustment of the wrap, inconsistent length between marks, and slipping during transmission. With this function, the cutter is able to quickly complete positioning and return to the correct cutting spot.

#### System scheme

There are two parts in the packing machine system, the master axis (controller) and three slave axes (conveyor, wrap feeder, and heat sealer with cutter). The controller is the pulse source for the master axis. It outputs the pulse signals to the slave axis and performs logic condition check for the auxiliary functions. The main function for the chain conveyor is to convey the contents to be packed to the work station. The main function for the wrap feeder is to feed the wrap to the work station for packing the content. The heat sealer with cutter is to seal and cut, which is the final step of packing. See Figure 7.3.11.1.

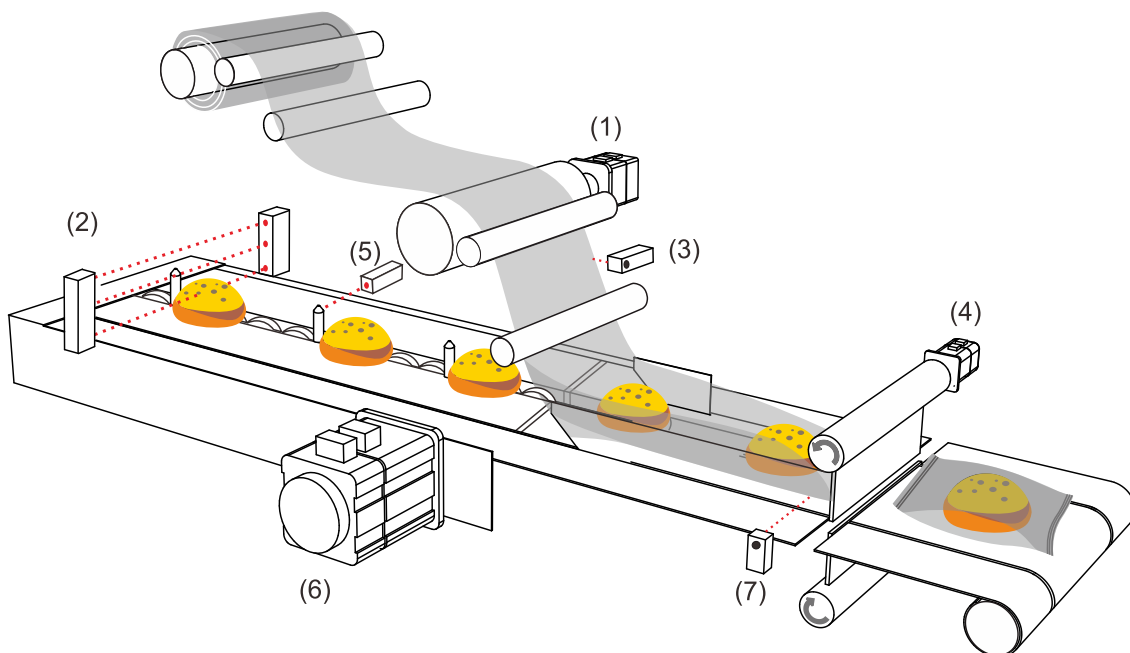

- (1) Wrap feeder (slave axis)
- (2) Empty pack detection sensor
- (3) Mark sensor for E-Cam phase alignment
- (4) Heat sealer with cutter (slave axis)
- (5) Mark sensor for synchronous Capture axis
- (6) Chain conveyor (slave axis)
- (7) Sensor for avoiding miscutting

Figure 7.3.11.1 Horizontal packing machine

## 7

- **Controller (master axis)**

The controller controls the operation mechanism for the horizontal packing machine and judges the logic for the auxiliary functions. In addition, the controller is the pulse source for the master axis and it sends stable pulse signals to the slave axes, and the slave axes operate based on these pulse signals.
- **Chain conveyor (slave axis)**

This axis conveys the contents to be packed. The following two slaves (wrap feeder and heat sealer with cutter) perform E-Cam phase alignment based on the marking on this chain conveyor.
- **Wrap feeder (slave axis)**

This axis feeds the packing wraps. The feeding of the packing wrap has to be smooth. For example, the tension output by the mechanism cannot be too great, or the packing wrap can be over-extended. However, if the tension is not high enough, slippery on the wrap feed roller might occur. When any of these two circumstances occurs, it means the output master pulses do not match the packing film length. In this case, use the phase alignment compensation function provided by the servo drive for correction.
- **Heat sealer with cutter (slave axis)**

The design for the heat sealer with cutter needs to take the proportion of the cutting length and cutting interval into consideration. If the cutting length is too short, it can cause a drastic change in cutter rotation speed or the motor torque might exceed the output limit. So, you can consider to increase the cutter number to reduce the cutter interval, making the rotation speed smoother. For packing machine applications, the cutter has both the heat sealing and cutting functions, thus when plotting the E-Cam curves, the synchronous speed zone has to be greater for the cutter to complete the cutting and heat sealing.

**Servo system setting**

■ Framework

The controller outputs the pulse signals to the chain conveyor. When the chain conveyor delivers the packing contents, it uses the pulse by-pass function built in the servo drive to transmit the pulses to other slave axes at the same time, so the master axis can send pulses to other slave axes with the slave drives. The delay time for each axis is 50 ns and the pulse signal does not attenuate during transmission.

To use the E-Cam phase alignment function, install the mark sensor on the wrap feeder and use DI: [0x35]ALGN to correct the E-Cam phase. The mark sensor for the synchronous Capture axis is installed on the chain conveyor and sends the signals through the high-speed input point (DI7) to the servo drives controlling the wrap feeder and cutter. In other words, the synchronous Capture axis provides the source pulses for E-Cam master axis of these two servo drives. The electrical framework is as shown in Figure 7.3.11.2.

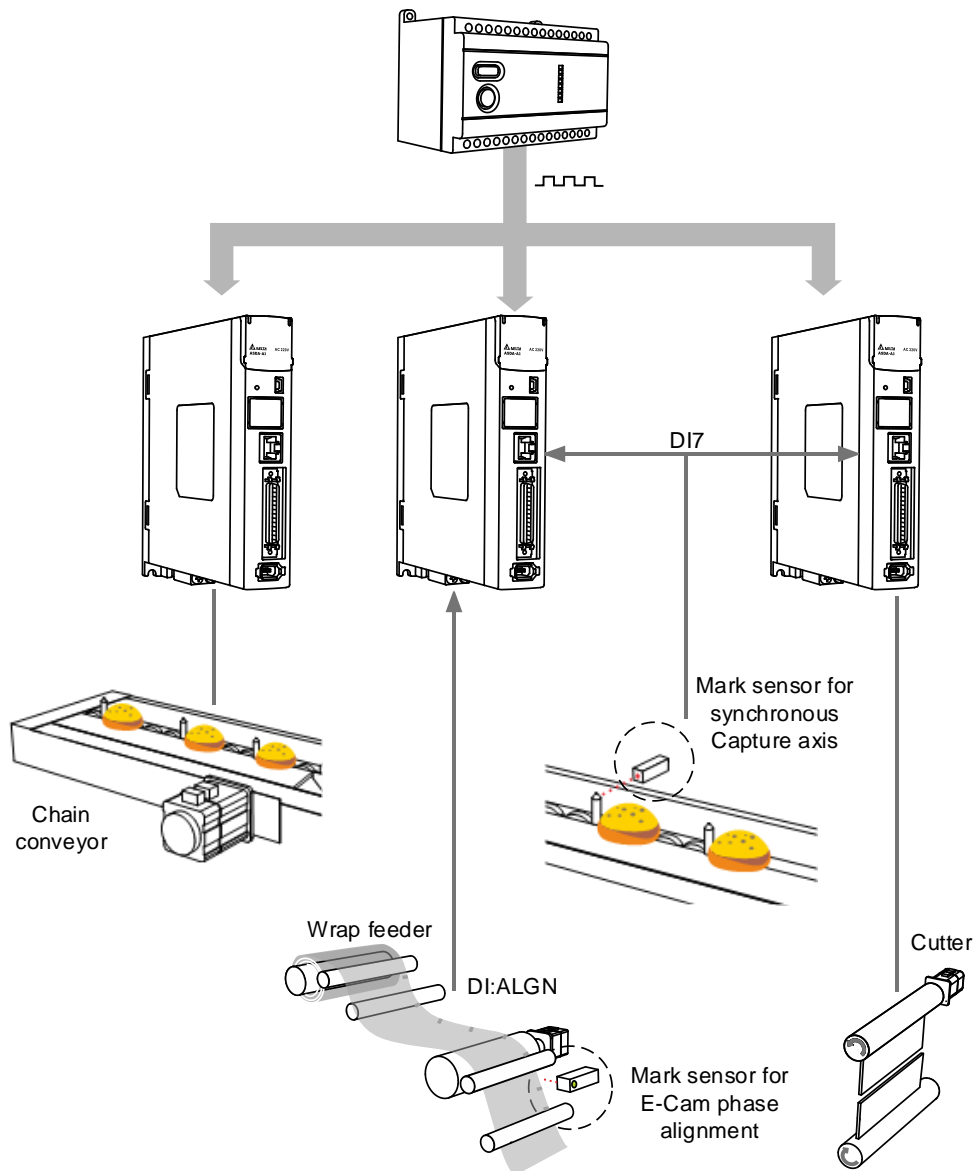

Figure 7.3.11.2 Horizontal packing machine framework



7

You can install a sensor on the packing machine to avoid empty packs or miscutting the content when the content is in the wrong position. In the empty pack prevention mechanism, the empty pack detection sensor is installed on the chain conveyor and sends signals to the controller. Next, the controller counts and calculates the timings for triggering the empty pack PR path of the two slave axes and enabling Macro #10, thus avoiding generating empty packs.

For the miscutting prevention mechanism, install the miscutting detection sensor on the cutting device. By doing so, the sensor can directly return the signals to the servo drive controlling the cutter through the digital input point. When detecting the packing content position error, the sensor triggers the miscutting prevention PR path and enables Macro #F to avoid damages to the machine or cutter caused by content position errors while cutting.

The electrical framework for empty pack prevention and miscutting prevention is as shown in Figure 7.3.11.3. When an error occurs and causes the machine to stop and the slave axis actual position is inconsistent with the E-Cam phase, use Macro #D to re-align the E-Cam phase. Details about the error detection mechanisms are described in the following sections (Empty pack prevention mechanism, Miscutting prevention mechanism, and Reset mechanism after alarm stops).

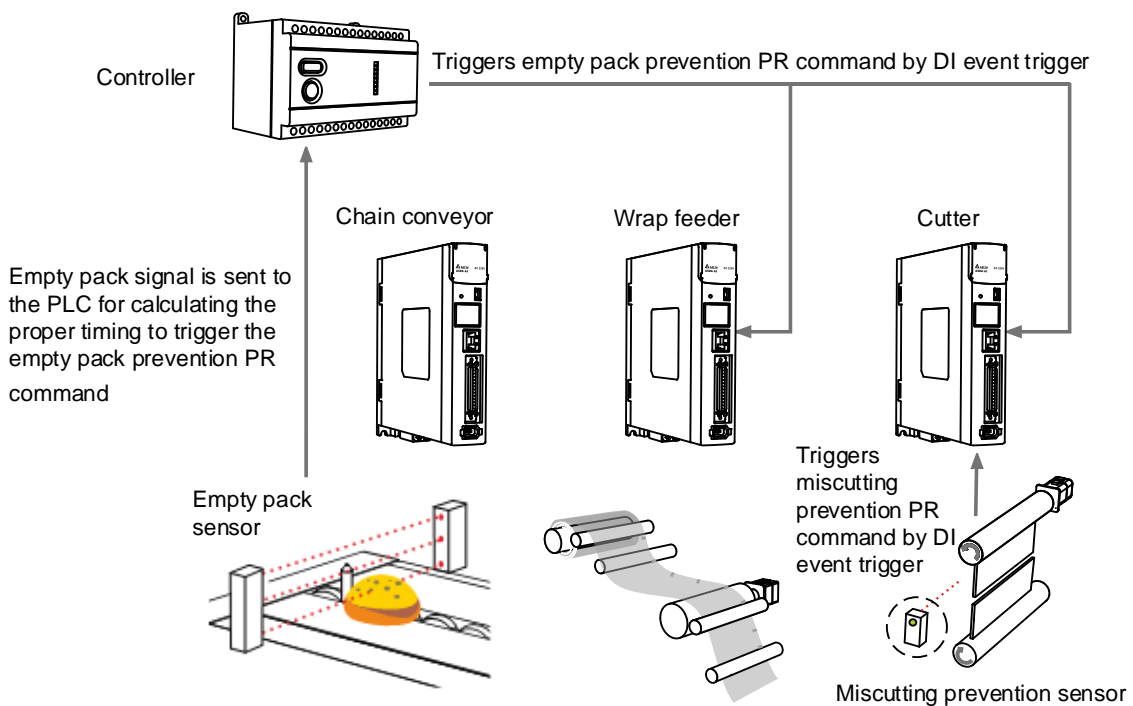

Figure 7.3.11.3 Horizontal packing machine error detection framework

### ■ E-Cam curve plotting

On the horizontal packing machine, the chain conveyor, wrap feeder, and cutter all require E-Cam curve settings. Both the chain conveyor and wrap feeder follow the master axis pulses for constant speed motion, which makes the E-Cam curve a slope. You can complete the setting with ASDA-Soft. Regarding the cutter axis with heat sealer, use [Rotary shear - adjustable sealing zone] in the ASDA-Soft to complete its E-Cam curve.

1. Cutter axis: select [Rotary shear - adjustable sealing zone] in the ASDA-Soft and fill in the packing machine specifications in the table, as shown in the following example.

For detailed settings, refer to Section 7.3.7. In this example, the master pulse number is automatically calculated by the software, which means the E-Gear ratio  $P5.084 = 79577$  and  $P5.083 = 1$ . Set the E-Gear ratio by setting  $P1.044$  to 16777216 and  $P1.045$  to 100000.

Motor gear number (A)	1
Cutter gear number (B)	5
Cutter number	1
Cutter diameter (d1)	200 mm
Encoder diameter (d2)	20 mm
Pulse per encoder revolution (N)	10000
Cutting length (L)	500 mm

2. Wrap feeder: select [Manually create a table] in the ASDA-Soft. See the following example. The roll diameter for dragging the packing wrap is 20 mm, so the wrap feeder feeds the wrap of 62.83 mm per roll revolution. A cutting length of 500 mm requires 50,000 PUU. Every time the machine operates 50,000 PUU, the motor operates 250,000 PUU. In this case, set the E-Gear ratio by setting  $P1.044$  to 16777216 and  $P1.045$  to 50000 and create a constant speed E-Cam curve with a total lead of 250,000 PUU. The E-Cam gear ratio of this axis must be consistent with the cutter axis, which means  $P5.084 = 79577$  and  $P5.083 = 1$ .

Cam phase (°)	0	72	144	216	288	360
Cutter axis position (PUU)	0	20000	40000	60000	80000	100000

3. Chain conveyor axis: select [Manually create a table] in the ASDA-Soft. See the following example. If the command resolution is 1 mm corresponding to 100 PUU, then each chain interval of 500 mm requires 50,000 PUU.

Cam phase (°)	0	72	144	216	288	360
Cutter axis position (PUU)	0	20000	40000	60000	80000	100000

## 7

**■ Synchronous Capture axis**

The slave axis of the horizontal packing machine operates based on the pulses received from the master axis. If the slave axis does not receive the pulses as it is set, then the slave axis is not able to cut and pack correctly. For example, when the master axis sends 10,000 pulses, the cutter cuts with the correct cutting length. When the master axis sends 10,000 pulses but the cutter receives 11,000 pulses, the cutter starts cutting upon receiving the 10,000<sup>th</sup> pulse, thus the actual cutting length will be shorter than the correct cutting length. When the master axis sends 10,000 pulses but the cutter only receives 9,000 pulses, the cutter waits and starts cutting only after it receives the 10,000<sup>th</sup> pulse, thus the actual cutting length will be longer than the correct cutting length.

To solve this problem, you can have the servo drive compare the set pulse number between two marks and the pulse number actually received, and then adjust the cutting length based on this deviation. In this example, the servo drive compares the actual pulse number transmitted through DI7 (the high-speed digital input point) between two triggers and the set master pulse number. Then, the pulse correction function will refer to this pulse difference to correct the signal. The corrected signal becomes the source for the synchronous Capture axis. And this synchronous Capture axis is regarded as the pulse source for the master axis to drive the slave axes. In addition, the pulse number from the master axis corresponding to the slave axis changes with the synchronous Capture axis. For detailed settings, refer to Section 7.3.7.

**■ E-Cam phase alignment**

First set the position for the phase alignment. The servo drive calculates the deviation between the actual position and the set position every operation cycle and makes correction. When the E-Cam phase alignment sensor reads the mark, it sends the signal to the DI point of the servo drive. Meanwhile, the servo drive examines whether the master axis is at the set position and calculates the displacement between the slave axis for correction. In this example, if the E-Cam requires 79,577 pulses from the master to operate one cycle, then  $P5.084 = 79577$  and  $P5.083 = 1$ . The master axis pulse number is 30,000 when the system reads the positioning signal. When the packing machine starts operating and after the mark signal is sent to the servo drive, if the master pulse number is 29,000, then the servo drive knows that there is a deviation of 1,000 master axis pulses from the target. The servo drive calculates the position error of the slave axis based on this deviation and writes this correction amount to the PR program. The servo drive triggers the PR commands when the set conditions are fulfilled and completes the E-Cam phase alignment by overlapping the commands. For detailed settings, refer to Section 7.3.7.

- Empty pack prevention mechanism

In packing machine applications, when the slave axes (wrap feeder and cutter) operate one cycle, the master axis (chain conveyor) travels one fixed packing distance. Use the two sets of E-Cam DO, [0x18]CAM\_AREA1 and [0x1A]CAM\_AREA2, to set the empty pack detection position and the slave axis pause position.

First set of DO: [0x18]CAM\_AREA1:

When DO.CAM\_AREA1 signal is on, the controller has to read the signal from the empty pack prevention sensor. If the sensor sends a signal, it means there is a packing content on the chain conveyor within this packing distance. If the sensor sends no signal, it means there is no packing content within this packing distance and requires to enable the empty pack prevention mechanism. Set the distance between the detection spot and the cutting spot for the controller. If the detection spot is 5 fixed packing distances away from the cutting spot, then the controller needs to complete the packing for the previous five packs. After DO.CAM\_AREA2 is on, the controller calls the PR command to execute Macro #10 to enable the empty pack prevention mechanism.

Second set of DO: [0x1A]CAM\_AREA2:

It is for setting the slave axis pause position. Generally, this setting should not affect the master axis motion. It is suggested that the slave axis pauses at the 0° position in the E-Cam curve. Since the slave axis requires to accelerate from a stop to the operation stage, you can use the acceleration curve to have the slave axis follow the E-Cam curve closely after the slave axis resumes operation.

7

For the empty pack prevention mechanism, it uses the controller to call the PR command for the two slave axes, which executes Macro #10. When the macro is executed, these two slave axes pause for one E-Cam cycle and then resume the operation in the next cycle. If there are two consecutive empty packs, the mechanism can trigger Macro #10 for two consecutive times. When using this function, use the PR special filter (P1.022) to avoid drastic speed change of the slave axes.

The operation is shown in Figure 7.3.11.4.

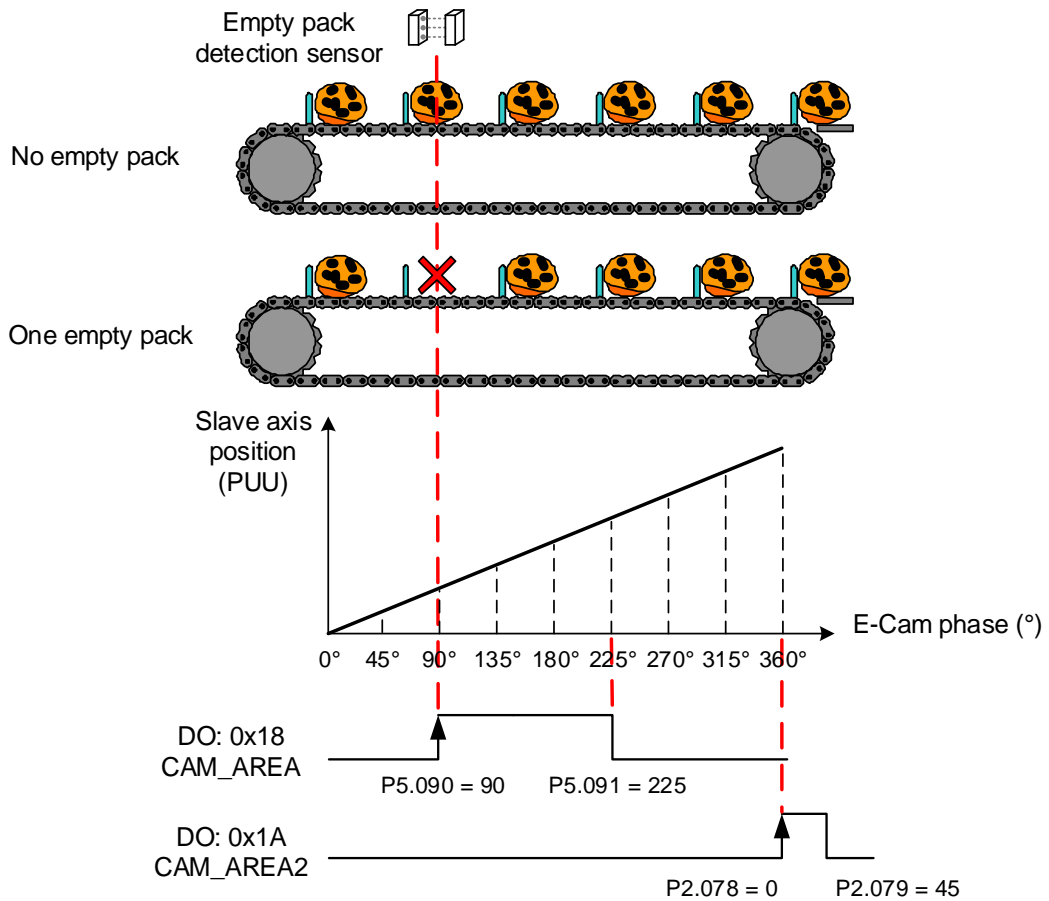

Figure 7.3.11.4 Empty pack prevention mechanism

■ Miscutting prevention mechanism

Sometimes the position of the packing content shifts on the chain conveyor, so the cutter might cut the content, causing damage to the cutter or machine. To avoid this issue, install a sensor for preventing miscutting. When the sensor detects no packing contents, it means the content is not in the right position and the miscutting prevention mechanism needs to be activated. To use this mechanism, set the following conditions: the clutch remains engaged when Servo Off, the E-Cam curve scaling (P5.019) starts taking effect upon the next engagement, and return to the pre-engage status after disengagement.

When DO: CAM\_AREA1 is rising-edge triggered and the sensor detects no packing content, use the DI event to trigger the PR path and activate the miscutting prevention mechanism. Use Macro #F to calculate the deviation between the cutter axis current position and the target position, and write this deviation data to the specified PR number. Set the E-Cam curve scaling (P5.019) to 0 and use Macro #8 to activate the scaling setting. When the master axis keeps operating and the clutch is engaged, the cutter will pause because the scaling setting is 0. After Macro #8 is triggered, the E-Cam curve scaling (P5.019) is reset to the original value. Meanwhile, execute the PR incremental position command specified in Macro #F to return the cutter to the specified position and wait for the pre-engagement cycle to complete, and then the cutter keeps operating when it is re-engaged.

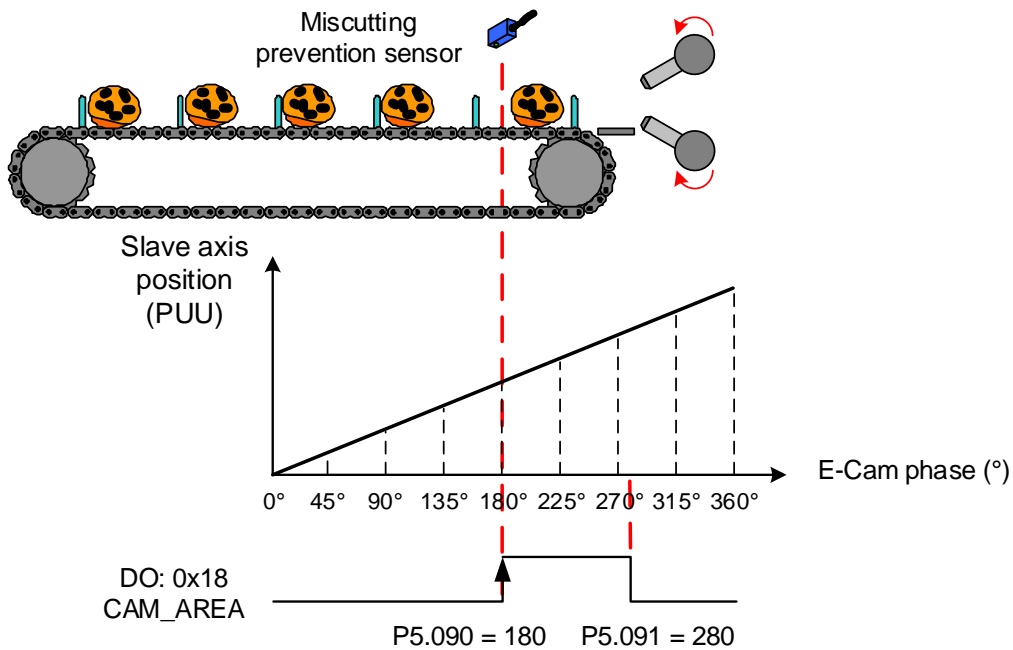

Figure 7.3.11.5 Miscutting prevention mechanism

## 7

- Reset mechanism after alarm stops

When the packing machine stops because of an alarm, the E-Cam phase might shift because of the external force or other factors. Correct the E-Cam phase before restarting the machine so it can cut and pack correctly. The wrap feeder has the E-Cam phase alignment function which can automatically complete the alignment by reading the mark positions. For the cutter axis, use Macro #D to complete the phase alignment before the machine resumes operation. Macro #D calculates the deviation between the cutter current position and the target position corresponding to the master axis. Then, it writes the deviation data to the specified PR incremental position command and triggers this PR command to complete the E-Cam phase alignment.

- Manually adjust the slave axis

To manually adjust the packing wrap to the position near the cutting spot, use the virtual pulses (P2.077) to fine-tune the positions of the wrap feeder and cutter axes, so the machine can perform the first cut at the correct position. To adjust the slave axis position during packing machine operation, you can also use the virtual pulse function to fine-tune the position. In the virtual pulse function, you can select whether to mask the master pulses and the virtual pulse compensation type. For detailed settings, refer to Section 7.3.10.

### PR program settings

- Wrap feeder

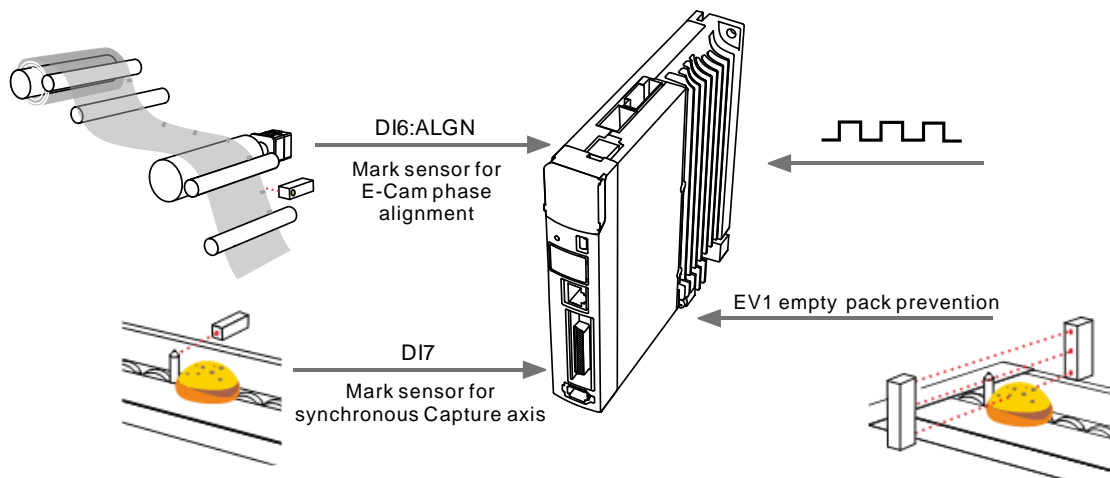

1. Setting for synchronous Capture axis and E-Cam phase alignment:

The steps for enabling the E-Cam have to include settings for the synchronous Capture axis and E-Cam phase alignment. See the following figure. PR#20 - 25 set the synchronous Capture axis and enable the E-Cam. PR#19 and PR#26 - 27 set the E-Cam phase alignment and the other PR commands are the correction settings for phase alignment of the three stages.

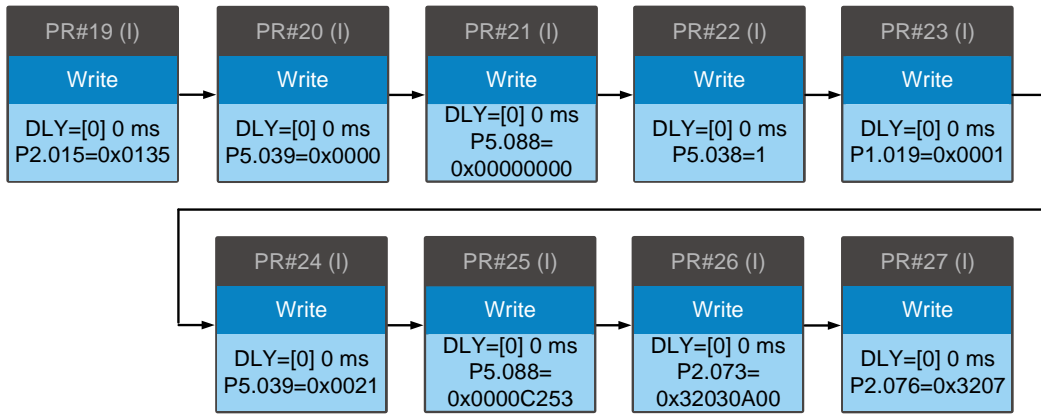

Execute the phase alignment of the 1<sup>st</sup> stage and set the 2<sup>nd</sup> stage

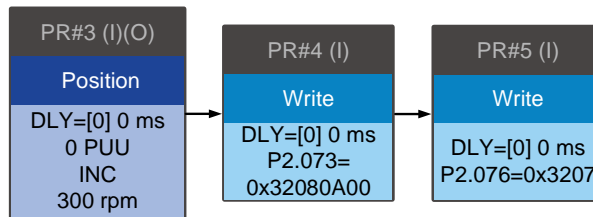

Execute the phase alignment of the 2<sup>nd</sup> stage and set the 3<sup>rd</sup> stage

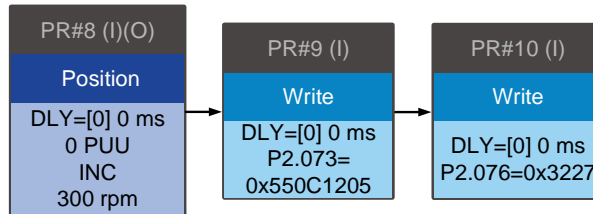

Execute the phase alignment of the 3<sup>rd</sup> stage

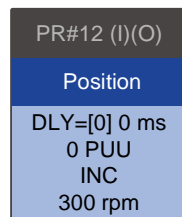



The function for each PR command is as follows.

PR#19	Specifies DI6 as the mark reading signal (input to the servo drive) for E-Cam phase alignment.
PR#20 PR#21	Disables the Capture and E-Cam functions. Disable the capturing and E-Cam functions before using the PR commands to set the parameters for high-speed position capturing and E-Cam.
PR#22	Sets the amount to capture.
PR#23	Enables the Cyclic Capture mode.
PR#24	Enables the high-speed Capture function and sets the pulse source.
PR#25	Enables the E-Cam function. Sets the synchronous Capture axis as the source for the master axis. Regards the capturing action as the clutch engagement timing. Sets the clutch to remain engaged when an alarm occurs or the servo is off and enter the cyclic mode after the clutch disengages.
PR#26	Sets the E-Cam phase alignment of the first stage. Disables the filter function, sets the maximum correction rate to 10% and the masking range of 50%, and writes the correction amount to PR#3.
PR#27	Sets and enables the E-Cam phase alignment of the first stage. Sets the allowable forward rate to 50% and immediately triggers the correction PR command.
PR#3	Uses the incremental position command to correct the phase for the first time.
PR#4	Sets the E-Cam phase alignment of the second stage, which is the same as the first stage. Writes the correction amount to PR#8.
PR#5	Sets and enables the E-Cam phase alignment of the second stage, which setting is the same as that of the first stage.
PR#8	Uses the incremental position command to correct the phase for the second time.
PR#9	Sets the E-Cam phase alignment of the third stage. Enables the filter function when the correction amount is less than 5%. Sets the maximum correction rate to 18% and the masking range of 85%, and writes the correction amount to PR#12.
PR#10	Enables the E-Cam phase alignment of the second stage. Sets the allowable forward rate to 50% and the filter volume to 2. Immediately triggers the correction PR command.
PR#12	Uses the incremental position command to correct the phase for the third time.

2. Function for manually adjusting the wrap:

This function allows you to manually adjust the wrap in both forward and reverse directions.

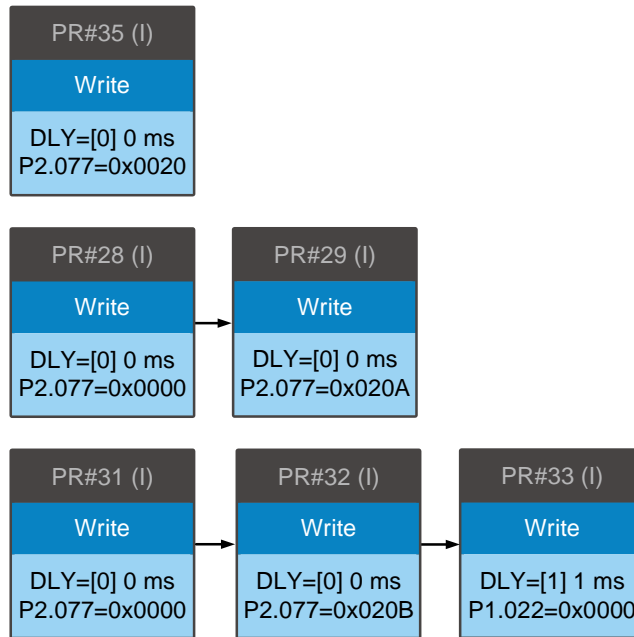

PR#28 PR#29	Forward adjustment. PR#28 confirms the virtual master axis function is disabled. PR#29 sets to continuously receive pulses from the master axis and the virtual master axis continues to send pulses at 2 Kpps.
PR#31 PR#32 PR#33	Reverse adjustment. PR#31 confirms the virtual master axis function is disabled. PR#32 sets to continuously receive pulses from the master axis and the virtual master axis continues to send pulses at -2 Kpps. PR#33 disables the reverse inhibit function. If the fine tuning is complete, execute PR#35 to disable the virtual master axis.

3. Empty pack prevention:

When the empty pack sensor does not detect the packing content, it uses the DI event trigger to enable the function to avoid empty packs.

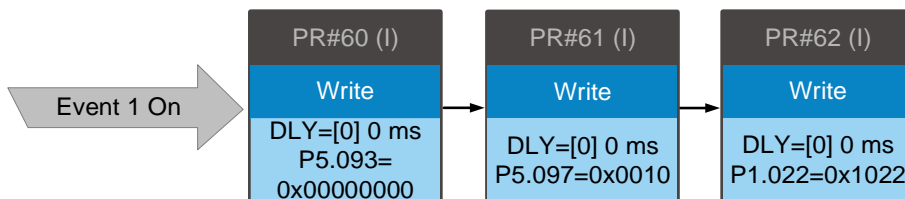

PR#60	Rising-edge triggers Event 1 to set the macro parameter P5.093 to 0.
PR#61	Executes Macro #10 to immediately stop the wrap feeder operation for one cycle.
PR#62	Inhibits the reverse operation and enables the filter when the acceleration or deceleration time is less than 340 ms.

■ Heat sealer with cutter

7

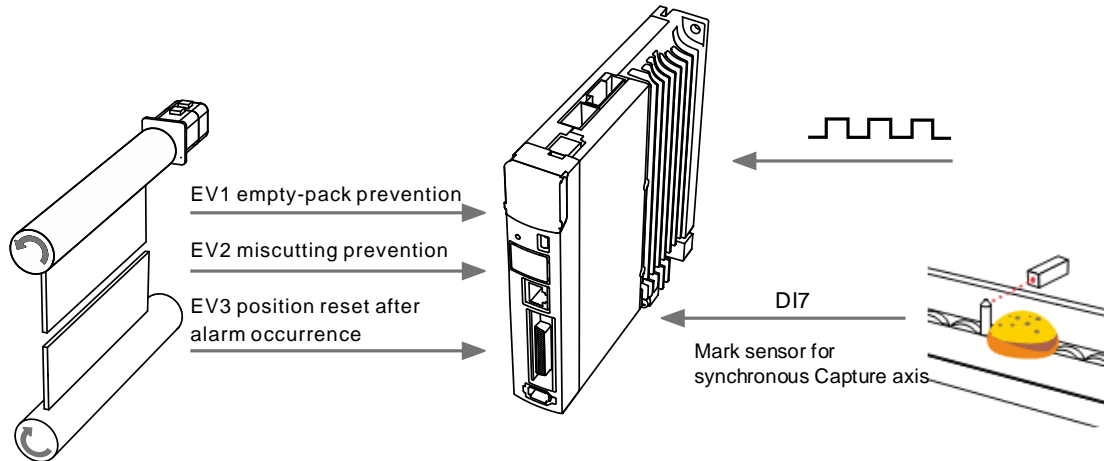

1. Settings for synchronous Capture axis:

Enable the synchronous Capture axis when enabling the E-Cam.

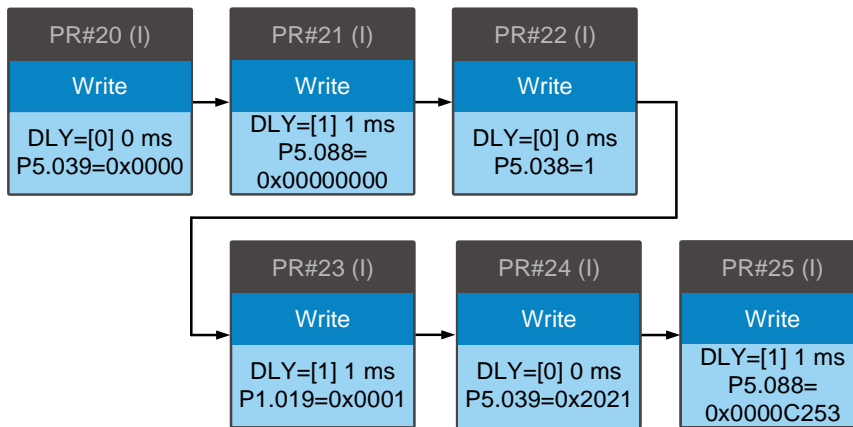

PR#20 PR#21	Disables the Capture and E-Cam functions. Disable the capturing and E-Cam functions before using the PR commands to set the parameters for high-speed position capturing and E-Cam.
PR#22	Sets the amount to capture.
PR#23	Enables the Cyclic Capture mode.
PR#24	Enables the high-speed Capture function and sets the pulse source.
PR#25	Enables the E-Cam function. Sets the synchronous Capture axis as the source for the master axis. Regards the capturing action as the clutch engagement timing. Sets the clutch to remain engaged when an alarm occurs or the servo is off, enter the cyclic mode after the clutch disengages, and reduce the speed variation to that of the pre-engage status.

2. Function for manually adjusting the cutter positioning:

The manual positioning function allows adjustments in both forward and reverse directions.

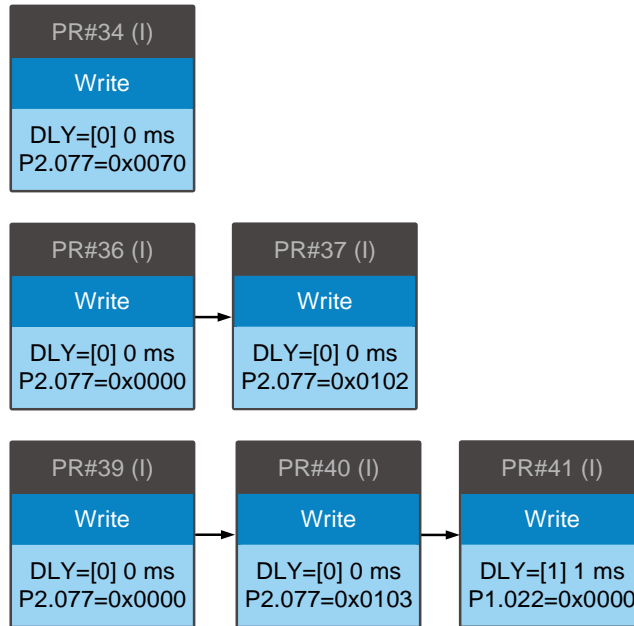

PR#36 PR#37	Forward adjustment. PR#36 confirms the virtual master axis function is disabled. PR#37 sets the master axis pulses to mask and the virtual master axis continues to send pulses at 1 Kpps.
PR#39 PR#40 PR#41	Reverse adjustment. PR#39 confirms the virtual master axis function is disabled. PR#40 sets the master axis pulses to mask and the virtual master axis continues to send pulses at -1 Kpps. PR#41 disables the reverse inhibit function.

If the positioning is complete, execute PR#34 to disable the virtual master axis function.

To prevent the cutter from cutting before the wrap arrives the target position, write the virtual master axis pulse number plus pulses of one cycle to EEPROM. This ensures the cutter cuts only when the wrap reaches the right position.

3. Empty pack prevention:

When the empty pack sensor does not detect the packing content, it uses the DI event trigger to enable the function to avoid empty packs.

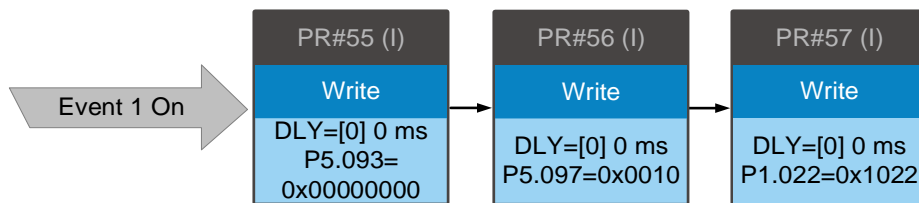

PR#55	Rising-edge triggers Event 1 to set the macro parameter P5.093 to 0.
PR#56	Executes Macro #10 to immediately stop the wrap feeder operation for one cycle.
PR#57	Inhibits the reverse operation and enables the filter when the acceleration or deceleration time is less than 340 ms.

4. Miscutting prevention:

When the sensor for preventing miscutting does not detect the packing content in the package, it uses the DI event trigger to enable the miscutting prevention function.

7

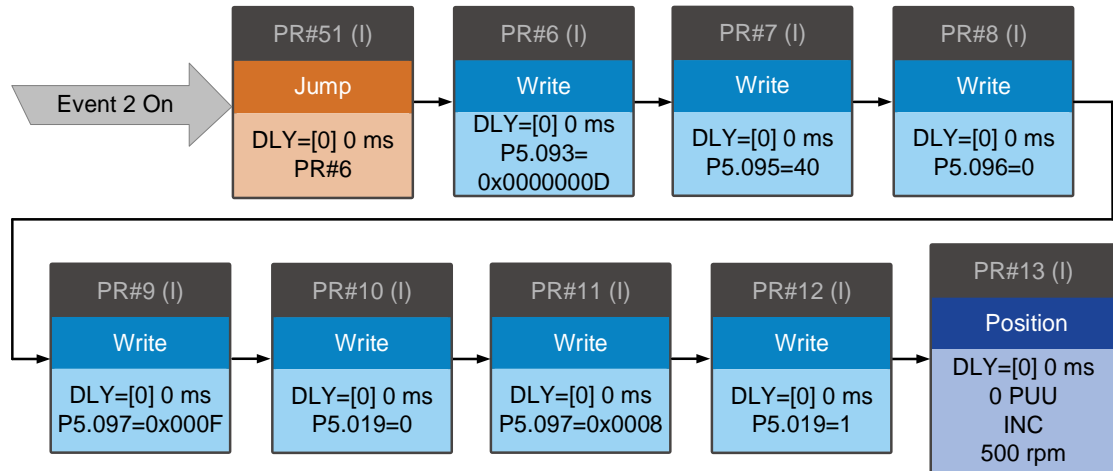

PR#51	Rising-edge triggers Event 2 to trigger the jump procedure to jump to PR#6.
PR#6	Writes the deviation between the E-Cam current position and the target position to PR#13.
PR#7	Sets the allowable forward rate to 40%.
PR#8	Sets the target position as the position when the master axis pulse is 0.
PR#9	Executes Macro #F to calculate the deviation between the E-Cam current position and target position.
PR#10	Sets the E-Cam scaling to 0.
PR#11	Executes Macro #8 to have PR#10 immediately take effect so the cutter stops operating.
PR#12	Resets the scaling to default.
PR#13	Uses the incremental position command to have the cutter operate to the target position.

5. Reset after alarm:

After the alarm is cleared, the cutter has to return to where it was before the alarm occurrence. Use the DI event trigger to enable Macro #D, set the rotary axis position scale (P2.052) as the moving amount of the cutter in a cycle, and set E-Cam curve scaling (P5.019) to 1.

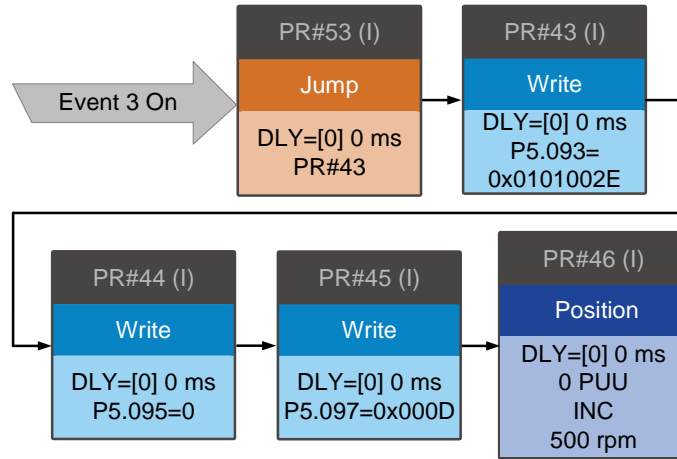

PR#53	Rising-edge triggers Event 3 to trigger the jump procedure to jump to PR#43.
PR#43	Writes the deviation between the position before the alarm occurrence and the current position to PR#46. Sets to inhibit the reverse operation.
PR#44	Sets the allowable forward rate to 0%.
PR#45	Executes Macro #D to calculate the deviation between the position before the alarm occurrence and the current position.
PR#46	Uses the incremental position command to move the cutter back to the position before the alarm occurrence.

(This page is intentionally left blank.)

7

# Parameters

# 8

This chapter introduces the parameter settings of the servo drive, as well as the descriptions for digital input (DI) and digital output (DO). You can control the drive functions with these parameters and DI/O.

8.1	Parameter definitions .....	8-2
8.2	List of parameters .....	8-3
8.3	Parameter descriptions .....	8-25
P0.xxx	Monitoring parameters .....	8-25
P1.xxx	Basic parameters .....	8-42
P2.xxx	Extension parameters .....	8-93
P3.xxx	Communication parameters .....	8-141
P4.xxx	Diagnosis parameters .....	8-151
P5.xxx	Motion control parameters .....	8-161
P6.xxx	PR parameters .....	8-204
P7.xxx	PR parameters .....	8-228
PM.xxx	Motor parameters .....	8-248
Table 8.1	Digital input (DI) descriptions .....	8-267
Table 8.2	Digital output (DO) descriptions .....	8-275
Table 8.3	Monitoring variables descriptions .....	8-282



## 8

## 8.1 Parameter definitions

The servo drive parameters are divided into nine groups. The first character after the start code P is the group character and the following three characters are the parameter indicator. The communication address is the combination of the group number and the three-digit number, expressed in hexadecimal. The parameter groups are:

- Group 0: Monitoring parameters (Example: P0.xxx)
- Group 1: Basic parameters (Example: P1.xxx)
- Group 2: Extension parameters (Example: P2.xxx)
- Group 3: Communication parameters (Example: P3.xxx)
- Group 4: Diagnosis parameters (Example: P4.xxx)
- Group 5: Motion control parameters (Example: P5.xxx)
- Group 6: PR parameters (Example: P6.xxx)
- Group 7: PR parameters (Example: P7.xxx)
- Group M: Motor parameters (Example: PM.xxx)

### Control mode description:

- PT: Position control (command input through terminal block)
- PR: Position control (command sent from internal register)
- S: Speed control
- T: Torque control
- CANopen, DMCNET, and EtherCAT: Communication control

### Special symbol description:

Icon of parameter property	Description
★	Read-only parameter. Can only read the value of the parameter. For example, P0.000, P0.010, and P4.001.
▲	Parameter cannot be changed when servo is in Servo On status. For example, P1.000 and P1.046.
●	Parameter changes become valid after power cycling. For example, P1.001 and P3.000.
■	Parameter resets to its default value after power cycling. For example, P3.006.

## 8.2 List of parameters

### Monitoring and general output parameters

Parameter No.	Function	Default value	Unit	Control mode			
				PT	PR	S	T
P0.000★	Firmware version	Factory setting	-	○	○	○	○
P0.001■	Current drive alarm code (seven-segment display)	-	-	○	○	○	○
P0.002	Drive status	1	-	○	○	○	○
P0.003	Analog output monitoring	0x0000	-	○	○	○	○
P0.008★	Total servo drive operation time	0x00000000	hour	○	○	○	○
P0.009★■	Status monitoring register 1	-	-	○	○	○	○
P0.010★■	Status monitoring register 2	-	-	○	○	○	○
P0.011★■	Status monitoring register 3	-	-	○	○	○	○
P0.012★■	Status monitoring register 4	-	-	○	○	○	○
P0.013★■	Status monitoring register 5	-	-	○	○	○	○
P0.017	Select content displayed by status monitoring register 1	0	-	○	○	○	○
P0.018	Select content displayed by status monitoring register 2	0	-	○	○	○	○
P0.019	Select content displayed by status monitoring register 3	0	-	○	○	○	○
P0.020	Select content displayed by status monitoring register 4	0	-	○	○	○	○
P0.021	Select content displayed by status monitoring register 5	0	-	○	○	○	○
P0.025■	Mapping parameter 1	-	-	○	○	○	○
P0.026■	Mapping parameter 2	-	-	○	○	○	○
P0.027■	Mapping parameter 3	-	-	○	○	○	○
P0.028■	Mapping parameter 4	-	-	○	○	○	○
P0.029■	Mapping parameter 5	-	-	○	○	○	○
P0.030■	Mapping parameter 6	-	-	○	○	○	○
P0.031■	Mapping parameter 7	-	-	○	○	○	○
P0.032■	Mapping parameter 8	-	-	○	○	○	○
P0.035	Target setting for mapping parameter P0.025	-	-	○	○	○	○
P0.036	Target setting for mapping parameter P0.026	-	-	○	○	○	○
P0.037	Target setting for mapping parameter P0.027	-	-	○	○	○	○
P0.038	Target setting for mapping parameter P0.028	-	-	○	○	○	○
P0.039	Target setting for mapping parameter P0.029	-	-	○	○	○	○
P0.040	Target setting for mapping parameter P0.030	-	-	○	○	○	○
P0.041	Target setting for mapping parameter P0.031	-	-	○	○	○	○
P0.042	Target setting for mapping parameter P0.032	-	-	○	○	○	○
P0.044★■	Status monitoring register (for PC software)	0	-	○	○	○	○

8

Parameter No.	Function	Default value	Unit	Control mode			
				PT	PR	S	T
P0.045■	Status monitoring register content selection (for PC software)	0	-	○	○	○	○
P0.046★■	Servo drive digital output (DO) status	0x0000	-	○	○	○	○
P0.050★■	Absolute position system status	0x0000	-	○	○	○	○
P0.063★	Total duration of DC Bus voltage exceeding 400V or 800V	0	ms	○	○	○	○
P0.079★	IGBT highest temperature	0	°C	○	○	○	○
P1.004	MON1 analog monitor output proportion	100	% (full scale)	○	○	○	○
P1.005	MON2 analog monitor output proportion	100	% (full scale)	○	○	○	○
P1.101■	Analog monitor output voltage 1	0	mV	○	○	○	○
P1.102■	Analog monitor output voltage 2	0	mV	○	○	○	○

- (★) Read-only parameter. Can only read the value of the parameter. For example, P0.000, P0.010, and P4.001.
- (▲) Parameter cannot be changed when servo is in Servo On status. For example, P1.000 and P1.046.
- (●) Parameter changes become valid after power cycling. For example, P1.001 and P3.000.
- (■) Parameter resets to its default value after power cycling. For example, P3.006.

## Filter and resonance suppression parameters

Parameter No.	Function	Default value	Unit	Control mode			
				PT	PR	S	T
P1.006	Speed command - smoothing constant (low-pass filter)	0	ms	-	-	O	-
P1.007	Torque command - smoothing constant (low-pass filter)	0	ms	-	-	-	O
P1.008	Position command - smoothing constant (low-pass filter)	0	10 ms	O	O	-	-
P1.025	Low-frequency vibration suppression frequency 1	1000	0.1 Hz	O	O	-	-
P1.026	Low-frequency vibration suppression gain 1	0	-	O	O	-	-
P1.027	Low-frequency vibration suppression frequency 2	1000	0.1 Hz	O	O	-	-
P1.028	Low-frequency vibration suppression gain 2	0	-	O	O	-	-
P1.029	Auto low-frequency vibration suppression mode	0	-	O	O	-	-
P1.030	Low-frequency vibration detection	8000	pulse	O	O	-	-
P1.034	S-curve acceleration constant	200	ms	-	-	O	-
P1.035	S-curve deceleration constant	200	ms	-	-	O	-
P1.036	S-curve acceleration / deceleration constant	0	ms	-	O	O	-
P1.061	Viscous friction compensation	0	0.1%/1000 rpm (rotary) 0.1%/1000 mm/s (linear)	O	O	O	-
P1.062	Percentage of friction compensation	0	%	O	O	O	-
P1.063	Constant of friction compensation	100	%	O	O	O	-
P1.068	Position command - moving filter	4	ms	O	O	-	-
P1.075	Low-pass filter time constant for full- / semi-closed loop control	100	ms	O	-	-	-
P1.089	Vibration elimination 1 - anti-resonance frequency	4000	0.1 Hz	O	O	-	-
P1.090	Vibration elimination 1 - resonance frequency	4000	0.1 Hz	O	O	-	-
P1.091	Vibration elimination 1 - resonance difference	10	0.1 dB	O	O	-	-
P1.092	Vibration elimination 2 - anti-resonance frequency	4000	0.1 Hz	O	O	-	-
P1.093	Vibration elimination 2 - resonance frequency	4000	0.1 Hz	O	O	-	-
P1.094	Vibration elimination 2 - resonance difference	10	0.1 dB	O	O	-	-
P2.023	Notch filter 1 - frequency	1000	Hz	O	O	O	O
P2.024	Notch filter 1 - attenuation level	0	-dB	O	O	O	O
P2.043	Notch filter 2 - frequency	1000	Hz	O	O	O	O
P2.044	Notch filter 2 - attenuation level	0	-dB	O	O	O	O
P2.045	Notch filter 3 - frequency	1000	Hz	O	O	O	O
P2.046	Notch filter 3 - attenuation level	0	-dB	O	O	O	O
P2.047	Auto resonance suppression mode	0x0001	-	O	O	O	O
P2.048	Auto resonance detection level	100	-	O	O	O	O

8

Parameter No.	Function	Default value	Unit	Control mode			
				PT	PR	S	T
P2.025	Resonance suppression low-pass filter	1.0 (panel / software)	1 ms (panel / software)	○	○	○	○
		10 (communication)	0.1 ms (communication)				
P2.049	Speed detection filter and jitter suppression	1.0 (panel / software)	1 ms (panel / software)	○	○	○	○
		10 (communication)	0.1 ms (communication)				
P2.084	Special function for low resolution motor	0x0000	-	○	○	○	○
P2.095	Notch filter 1 - Q factor	5	-	○	○	○	○
P2.096	Notch filter 2 - Q factor	5	-	○	○	○	○
P2.097	Notch filter 3 - Q factor	5	-	○	○	○	○
P2.098	Notch filter 4 - frequency	1000	Hz	○	○	○	○
P2.099	Notch filter 4 - attenuation level	0	-dB	○	○	○	○
P2.100	Notch filter 4 - Q factor	5	-	○	○	○	○
P2.101	Notch filter 5 - frequency	1000	Hz	○	○	○	○
P2.102	Notch filter 5 - attenuation level	0	-dB	○	○	○	○
P2.103	Notch filter 5 - Q factor	5	-	○	○	○	○
P2.113	Bandwidth of disturbance attenuation	50	Hz	-	-	-	○
P2.114	Level of disturbance attenuation	0	-	-	-	-	○

- (★) Read-only parameter. Can only read the value of the parameter. For example, P0.000, P0.010, and P4.001.
- (▲) Parameter cannot be changed when servo is in Servo On status. For example, P1.000 and P1.046.
- (●) Parameter changes become valid after power cycling. For example, P1.001 and P3.000.
- (■) Parameter resets to its default value after power cycling. For example, P3.006.

## Gain and switching parameters

Parameter No.	Function	Default value	Unit	Control mode			
				PT	PR	S	T
P1.037	Load inertia ratio or total weight	6.0 (panel / software)	1 times (rotary) 1 kg (linear) (panel / software)	O	O	O	-
		60 (communication)	0.1 times (rotary) 0.1 kg (linear) (communication)				
P1.078	Gain switching delay time	0	ms	O	O	O	-
P1.079	Rate of change for gain values during gain switching delay	100	%	O	O	O	-
P1.080	Rate of change for speed detection filter and jitter suppression	100	%	O	O	O	-
P2.000	Position control gain	35	rad/s	O	O	-	-
P2.001	Rate of change for position control gain	100	%	O	O	-	-
P2.002	Position feed forward gain	50	%	O	O	-	-
P2.003	Position feed forward gain smoothing constant	5	ms	O	O	-	-
P2.004	Speed control gain	500	rad/s	O	O	O	-
P2.005	Rate of change for speed control gain	100	%	O	O	O	-
P2.006	Speed integral compensation	100	rad/s	O	O	O	-
P2.007	Speed feed forward gain	0	%	O	O	O	-
P2.026	Anti-interference gain	0	rad/s	O	O	O	-
P2.027	Gain switching condition and method selection	0x0000	-	O	O	O	O
P2.028	Gain switching time constant	10	ms	O	O	O	O
P2.029	Gain switching condition	16777216	pulse Kpps rpm (mm/s)	O	O	O	O
P2.031	Bandwidth response level	19	-	O	O	O	O
P2.032	Gain adjustment mode	0x0001	-	O	O	O	O
P2.053	Position integral compensation	0	rad/s	O	O	-	-
P2.089	Command response gain	25	rad/s	O	O	-	-
P2.090	Two degree of freedom mode - anti-interference gain	850	0.001	O	O	-	-
P2.091	Two degree of freedom mode - position feed forward gain	1000	0.1%	O	O	-	-
P2.092	Two degree of freedom mode - speed feed forward gain	1000	0.1%	O	O	-	-
P2.094▲	Special bit register 3	0x1090 (A3-M, A3-L, A3-E) 0x0090 (A3-F)	-	O	O	O	O
P2.104	Torque command condition for P/PI switching	800	%	O	O	-	-
P2.105	Automatic gain adjustment level 1	11	-	O	O	O	O
P2.106	Automatic gain adjustment level 2	2000	pulse	O	O	O	O
P2.107	Rate of change for resonance suppression low-pass filter	100	%	O	O	O	O
P2.112▲	Special bit register 4	0x0018	-	O	O	O	O
P2.126	Bandwidth for speed loop response	40	Hz	O	O	O	O

## 8

- (★) Read-only parameter. Can only read the value of the parameter. For example, P0.000, P0.010, and P4.001.
- (▲) Parameter cannot be changed when servo is in Servo On status. For example, P1.000 and P1.046.
- (●) Parameter changes become valid after power cycling. For example, P1.001 and P3.000.
- (■) Parameter resets to its default value after power cycling. For example, P3.006.

## Position control parameters

Parameter No.	Function	Default value	Unit	Control mode			
				PT	PR	S	T
P1.001●	Input for control mode and control command	0x0000 (A3-M, A3-L) 0x000B (A3-F) 0x000C (A3-E)	-	○	○	○	○
P1.002▲	Speed and torque limits	0x0000	-	○	○	○	○
P1.003	Encoder pulse output polarity	0x0000	-	○	○	○	○
P1.012 - P1.014	Internal Torque command / internal torque limit 1 - 3	100	%	○	○	○	○
P1.044▲	E-Gear ratio - numerator N1	16777216	pulse	○	○	-	-
P1.045▲	E-Gear ratio - denominator M	100000	pulse	○	○	-	-
P1.046▲	Encoder pulse number output (OA, OB)	2500	pulse	○	○	○	○
P1.055	Maximum speed limit	Rated speed (rotary) Automatically fills in after motor parameter identification (linear)	1 rpm (rotary) 1 mm/s (linear)	○	○	○	○
P1.072	Resolution of auxiliary encoder for full-closed loop control	5000	pulse/rev	○	-	-	-
P1.073	Protection range for feedback position error between main encoder and auxiliary encoder	30000	pulse	○	-	-	-
P1.074	Full-closed loop control switch	0x0000	-	○	-	-	-
P1.076▲	Maximum speed for encoder output (OA, OB)	5500	1 rpm (rotary) 1 mm/s (linear)	○	○	○	○
P1.097▲	Encoder output denominator (OA, OB)	0	-	○	○	○	○
P1.111	Overspeed protection level	Maximum motor speed x 1.1	1 rpm (rotary) 1 mm/s (linear)	○	○	○	○
P1.112■	Single-direction torque limit	500	%	○	○	○	○
P2.035	Excessive deviation warning condition of Position command	50331648	pulse	○	○	-	-
P2.068	Following error compensation switch	0x00000000	-	-	○	-	-
P5.003	Deceleration time for auto-protection	0xEEEEFF	-	-	○	○	○
P5.016■	Axis position - main encoder	0	PUU	○	○	○	○
P5.017	Axis position - auxiliary encoder	0	pulse	○	○	○	○
P5.018	Axis position - pulse command	0	pulse	○	○	○	○
P5.020 - P5.035	Acceleration / deceleration times (#0 - #15)	Refer to description of each parameter	ms (P2.068.U = 0) 10 ms (P2.068.U = 1)	-	○	-	-



## Position control parameters - external pulse control command (PT mode)

Parameter No.	Function	Default value	Unit	Control mode			
				PT	PR	S	T
P1.000▲	External pulse input type	0x1042	-	O	-	-	-
P2.060	E-Gear ratio - numerator N2	16777216	pulse	O	-	-	-
P2.061	E-Gear ratio - numerator N3	16777216	pulse	O	-	-	-
P2.062	E-Gear ratio - numerator N4	16777216	pulse	O	-	-	-

- (★) Read-only parameter. Can only read the value of the parameter. For example, P0.000, P0.010, and P4.001.
- (▲) Parameter cannot be changed when servo is in Servo On status. For example, P1.000 and P1.046.
- (●) Parameter changes become valid after power cycling. For example, P1.001 and P3.000.
- (■) Parameter resets to its default value after power cycling. For example, P3.006.

8

## Position control parameters - internal register control command (PR mode)

Parameter No.	Function	Default value	Unit	Control mode			
				PT	PR	S	T
P5.004	Homing methods	0x0000	-	-	O	-	-
P5.005	High speed homing (first speed setting)	100.0 (rotary) 1000 (linear) (panel / software)	1 rpm (rotary) 1 μm/s (linear) (panel / software)	-	O	-	-
		1000 (communication)	0.1 rpm (rotary) 1 μm/s (linear) (communication)	-	O	-	-
P5.006	Low speed homing (second speed setting)	20.0 (rotary) 200 (linear) (panel / software)	1 rpm (rotary) 1 μm/s (linear) (panel / software)	-	O	-	-
		200 (communication)	0.1 rpm (rotary) 1 μm/s (linear) (communication)	-	O	-	-
P5.007■	Trigger Position command (PR mode only)	0	-	-	O	-	-
P5.008	Positive software limit	2147483647	PUU	-	O	-	-
P5.009	Negative software limit	-2147483648	PUU	-	O	-	-
P5.015■	PATH 1 - PATH 2 volatile setting	0x0000	-	-	O	-	-
P5.040 - P5.055	Delay time #0 - #15 after position reached	0 to 5500	ms	-	O	-	-
P5.060 - P5.075	Target speed setting #0 - #15	20.0 to 3000.0 (rotary) 20 to 3000 (linear) (panel / software)	1 rpm (rotary) 1 μm/s (linear) (panel / software)	-	O	-	-
		200 to 30000 (communication)	0.1 rpm (rotary) 1 μm/s (linear) (communication)	-	O	-	-
P5.098	PR number triggered by event rising-edge	0x0000	-	-	O	-	-
P5.099	PR number triggered by event falling-edge	0x0000	-	-	O	-	-
P6.002 - P7.099	Internal Position commands #1 - #99	0x00000000	-	-	O	-	-

- (★) Read-only parameter. Can only read the value of the parameter. For example, P0.000, P0.010, and P4.001.
- (▲) Parameter cannot be changed when servo is in Servo On status. For example, P1.000 and P1.046.
- (●) Parameter changes become valid after power cycling. For example, P1.001 and P3.000.
- (■) Parameter resets to its default value after power cycling. For example, P3.006.

8

## Speed control parameters

Parameter No.	Function	Default value	Unit	Control mode			
				PT	PR	S	T
P1.001●	Input for control mode and control command	0x0000 (A3-M, A3-L) 0x000B (A3-F) 0x000C (A3-E)	-	O	O	O	O
P1.002▲	Speed and torque limits	0x0000	-	O	O	O	O
P1.003	Encoder pulse output polarity	0x0000	-	O	O	O	O
P1.046▲	Encoder pulse number output (OA, OB)	2500	pulse	O	O	O	O
P1.055	Maximum speed limit	Rated speed (rotary) Automatically fills in after motor parameter identification (linear)	1 rpm (rotary) 1 mm/s (linear)	O	O	O	O
P1.074	Full-closed loop control switch	0x0000	-	O	-	-	-
P1.097▲	Encoder output denominator (OA, OB)	0	-	O	O	O	O
P1.009 - P1.011	Internal Speed commands 1 - 3	1000 to 3000	0.1 rpm (rotary) 1 μm/s (linear)	-	-	O	O
P1.012 - P1.014	Internal torque limits 1 - 3	100	%	O	O	O	O
P1.040	Maximum motor speed for analog Speed command 1	Rated speed	1 rpm (rotary) 1 mm/s (linear)	-	-	O	O
P1.081	Maximum motor speed for analog Speed command 2	Rated speed	1 rpm (rotary) 1 mm/s (linear)	-	-	O	O
P1.041▲	Maximum output for analog Torque command	100	%	O	O	O	O
P1.076▲	Maximum speed for encoder output (OA, OB)	5500	1 rpm (rotary) 1 mm/s (linear)	O	O	O	O
P1.111	Overspeed protection level	Maximum motor speed x 1.1	1 rpm (rotary) 1 mm/s (linear)	O	O	O	O
P1.112■	Single-direction torque limit	500	%	O	O	O	O
P2.034	Excessive deviation warning condition of Speed command	5000	1 rpm (rotary) 1 mm/s (linear)	-	-	O	-
P2.112▲	Special bit register 4	0x0018	-	O	O	O	O

- (★) Read-only parameter. Can only read the value of the parameter. For example, P0.000, P0.010, and P4.001.
- (▲) Parameter cannot be changed when servo is in Servo On status. For example, P1.000 and P1.046.
- (●) Parameter changes become valid after power cycling. For example, P1.001 and P3.000.
- (■) Parameter resets to its default value after power cycling. For example, P3.006.

## Torque control parameters

Parameter No.	Function	Default value	Unit	Control mode			
				PT	PR	S	T
P1.001●	Input for control mode and control command	0x0000 (A3-M, A3-L) 0x000B (A3-F) 0x000C (A3-E)	-	○	○	○	○
P1.002▲	Speed and torque limits	0x0000	-	○	○	○	○
P1.003	Encoder pulse output polarity	0x0000	-	○	○	○	○
P1.046▲	Encoder pulse number output (OA, OB)	2500	pulse	○	○	○	○
P1.055	Maximum speed limit	Rated speed (rotary) Automatically fills in after motor parameter identification (linear)	1 rpm (rotary) 1 mm/s (linear)	○	○	○	○
P1.009 - P1.011	Internal Speed command / internal speed limit 1 - 3	1000 to 3000	0.1 rpm (rotary) 1 μm/s (linear)*	-	-	○	○
P1.012 - P1.014	Internal Torque command / internal torque limit 1 - 3	100	%	○	○	○	○
P1.040	Maximum motor speed for analog Speed command 1	Rated speed	1 rpm (rotary) 1 mm/s (linear)	-	-	○	○
P1.081	Maximum motor speed for analog Speed command 2	Rated speed	1 rpm (rotary) 1 mm/s (linear)	-	-	○	○
P1.041▲	Maximum output for analog Torque command	100	%	○	○	○	○
P1.111	Overspeed protection level	Maximum motor speed x 1.1	1 rpm (rotary) 1 mm/s (linear)	○	○	○	○
P1.112■	Single-direction torque limit	500	%	○	○	○	○

(★) Read-only parameter. Can only read the value of the parameter. For example, P0.000, P0.010, and P4.001.

(▲) Parameter cannot be changed when servo is in Servo On status. For example, P1.000 and P1.046.

(●) Parameter changes become valid after power cycling. For example, P1.001 and P3.000.

(■) Parameter resets to its default value after power cycling. For example, P3.006.

8

## Digital input / Digital output functional planning parameters

Parameter No.	Function	Default value	Unit	Control mode			
				PT	PR	S	T
P0.053	General range compare digital output - filter time	0x0000	-	○	○	○	○
P0.054	General range compare digital output 1 - lower limit	0	-	○	○	○	○
P0.055	General range compare digital output 1 - upper limit	0	-	○	○	○	○
P0.056	General range compare digital output 2 - lower limit	0	-	○	○	○	○
P0.057	General range compare digital output 2 - upper limit	0	-	○	○	○	○
P0.058	General range compare digital output 3 - lower limit	0	-	○	○	○	○
P0.059	General range compare digital output 3 - upper limit	0	-	○	○	○	○
P0.060	General range compare digital output 4 - lower limit	0	-	○	○	○	○
P0.061	General range compare digital output 4 - upper limit	0	-	○	○	○	○
P2.009	DI response filter time	2	ms	○	○	○	○
P2.010	DI1 functional planning	0x0101 (A3-L, A3-M) 0x0100 (A3-F, A3-E)	-	○	○	○	○
P2.011	DI2 functional planning	0x0104 (A3-L, A3-M) 0x0100 (A3-F, A3-E)	-	○	○	○	○
P2.012	DI3 functional planning	0x0116 (A3-L, A3-M) 0x0100 (A3-F, A3-E)	-	○	○	○	○
P2.013	DI4 functional planning	0x0117 (A3-L, A3-M) 0x0124 (A3-F, A3-E)	-	○	○	○	○
P2.014	DI5 functional planning	0x0102 (A3-L, A3-M) 0x0022 (A3-F, A3-E)	-	○	○	○	○
P2.015	DI6 functional planning	0x0022 (A3-L, A3-M) 0x0023 (A3-F, A3-E)	-	○	○	○	○
P2.016	DI7 functional planning	0x0023 (A3-L, A3-M) 0x0021 (A3-F, A3-E)	-	○	○	○	○
P2.017	DI8 functional planning	0x0021 (A3-L, A3-M) 0x0100 (A3-F, A3-E)	-	○	○	○	○
P2.018	DO1 functional planning	0x0101	-	○	○	○	○
P2.019	DO2 functional planning	0x0103 (A3-L, A3-M) 0x0100 (A3-F, A3-E)	-	○	○	○	○

Parameter No.	Function	Default value	Unit	Control mode			
				PT	PR	S	T
P2.020	DO3 functional planning	0x0109 (A3-L, A3-M) 0x0100 (A3-F, A3-E)	-	○	○	○	○
P2.021	DO4 functional planning	0x0105 (A3-L, A3-M) 0x0007 (A3-F, A3-E)	-	○	○	○	○
P2.022	DO5 functional planning	0x0007 (A3-L, A3-M) 0x0100 (A3-F, A3-E)	-	○	○	○	○
P2.036	DI9 functional planning	0x0100	-	○	○	○	○
P2.037	DI10 functional planning	0x0100	-	○	○	○	○
P2.038	DI11 functional planning	0x0100	-	○	○	○	○
P2.039	DI12 functional planning	0x0100	-	○	○	○	○
P2.040	DI13 functional planning	0x0100	-	○	○	○	○
P2.041	DO6 functional planning	0x0100	-	○	○	○	○
P1.038	Zero speed range	10.0 (panel / software)	1 rpm (rotary) 1 mm/s (linear) (panel / software)	○	○	○	○
		100 (communication)	0.1 rpm (rotary) 0.1 mm/s (linear) (communication)				
P1.039	Target speed detection level	3000	1 rpm (rotary) 1 mm/s (linear)	○	○	○	○
P1.042	Delay time for enabling the magnetic brake	0	ms	○	○	○	○
P1.043	Delay time for disabling the magnetic brake	0	ms	○	○	○	○
P1.047	Speed reached (DO.SP_OK) range	10	1 rpm (rotary) 1 mm/s (linear)	-	-	○	-
P1.054	Pulse range for position reached	167772	pulse	○	○	-	-
P1.056	Motor output overload warning level	120	%	○	○	○	○

- (★) Read-only parameter. Can only read the value of the parameter. For example, P0.000, P0.010, and P4.001.
- (▲) Parameter cannot be changed when servo is in Servo On status. For example, P1.000 and P1.046.
- (●) Parameter changes become valid after power cycling. For example, P1.001 and P3.000.
- (■) Parameter resets to its default value after power cycling. For example, P3.006.

## 8

## Communication parameters

Parameter No.	Function	Default value	Unit	Control mode			
				PT	PR	S	T
P3.000●	Address	0x007F	-	O	O	O	O
P3.001●	Transmission speed	0x0203 (A3-M, A3-L, A3-E) 0x3203 (A3-F)	-	O	O	O	O
P3.002	Modbus communication protocol	0x0006	-	O	O	O	O
P3.003	Modbus communication error handling	0x0000	-	O	O	O	O
P3.004	Modbus communication timeout	0	sec	O	O	O	O
P3.006■	Digital input (DI) control switch	0x0000	-	O	O	O	O
P3.007	Modbus communication response delay time	1	0.5 ms	O	O	O	O
P3.009	Communication synchronization	0x5055	-	-	-	-	-
P3.010	CANopen / DMCNET protocol	0x1011	-	-	-	-	-
P3.011	CANopen / DMCNET options	0x0000	-	-	-	-	-
P3.012	Communication support setting	0x0000	-	-	-	-	-
P3.017	CANopen B mode disconnection delay time	1000	ms	-	-	-	-
P3.018	EtherCAT special function switch	0x00002000	-	-	-	-	-
P3.022	EtherCAT PDO timeout setting	0xFF04	-	-	-	-	-

- (★) Read-only parameter. Can only read the value of the parameter. For example, P0.000, P0.010, and P4.001.
- (▲) Parameter cannot be changed when servo is in Servo On status. For example, P1.000 and P1.046.
- (●) Parameter changes become valid after power cycling. For example, P1.001 and P3.000.
- (■) Parameter resets to its default value after power cycling. For example, P3.006.

## Diagnosis parameters

Parameter No.	Function	Default value	Unit	Control mode			
				PT	PR	S	T
P4.000	Fault record (last)	0x00000000	-	○	○	○	○
P4.001★	Fault record (second to the last)	0x00000000	-	○	○	○	○
P4.002★	Fault record (third to the last)	0x00000000	-	○	○	○	○
P4.003★	Fault record (fourth to the last)	0x00000000	-	○	○	○	○
P4.004★	Fault record (fifth to the last)	0x00000000	-	○	○	○	○
P4.005	Servo motor JOG control	20	1 rpm (rotary) 0.01 mm/s (linear)	○	○	○	○
P4.006■	Software digital output register (readable and writable)	0x0000	-	○	○	○	○
P4.007■	Multi-function for digital input	0x0000	-	○	○	○	○
P4.008★	Input status of servo drive panel (read-only)	-	-	○	○	○	○
P4.009★	Digital output status (read-only)	-	-	○	○	○	○
P4.010▲■	Hardware calibration options	0	-	○	○	○	○
P4.011	Analog speed input 1 - hardware offset calibration	Factory setting	-	○	○	○	○
P4.012	Analog speed input 2 - hardware offset calibration	Factory setting	-	○	○	○	○
P4.013	Analog torque input 1 - hardware offset calibration	Factory setting	-	○	○	○	○
P4.014	Analog torque input 2 - hardware offset calibration	Factory setting	-	○	○	○	○
P4.015	Current detector (V1 phase) - hardware offset calibration	Factory setting	-	○	○	○	○
P4.016	Current detector (V2 phase) - hardware offset calibration	Factory setting	-	○	○	○	○
P4.017	Current detector (W1 phase) - hardware offset calibration	Factory setting	-	○	○	○	○
P4.018	Current detector (W2 phase) - hardware offset calibration	Factory setting	-	○	○	○	○
P4.019	IGBT NTC calibration level (cannot reset)	Factory setting	-	○	○	○	-
P4.020	Analog monitor output (Ch1) - offset compensation value	0	mV	○	○	○	○
P4.021	Analog monitor output (Ch2) - offset compensation value	0	mV	○	○	○	○
P4.022	Analog speed input - offset compensation value	0	mV	-	-	○	-
P4.023	Analog torque input - offset compensation value	0	mV	-	-	-	○

- (★) Read-only parameter. Can only read the value of the parameter. For example, P0.000, P0.010, and P4.001.
- (▲) Parameter cannot be changed when servo is in Servo On status. For example, P1.000 and P1.046.
- (●) Parameter changes become valid after power cycling. For example, P1.001 and P3.000.
- (■) Parameter resets to its default value after power cycling. For example, P3.006.



## 8

## Encoder parameters

Parameter No.	Function	Default value	Unit	Control mode			
				PT	PR	S	T
P0.049■	Update encoder absolute position	0x0000	-	O	O	O	O
P0.051★■	Encoder absolute position - number of revolutions	0	rev	O	O	O	O
P0.052★■	Encoder absolute position - pulse number within single turn or PUU	0	pulse or PUU	O	O	O	O
P2.069●	Absolute encoder	0x0000	-	O	O	O	O

- (★) Read-only parameter. Can only read the value of the parameter. For example, P0.000, P0.010, and P4.001.
- (▲) Parameter cannot be changed when servo is in Servo On status. For example, P1.000 and P1.046.
- (●) Parameter changes become valid after power cycling. For example, P1.001 and P3.000.
- (■) Parameter resets to its default value after power cycling. For example, P3.006.

## E-Cam parameters

Parameter No.	Function	Default value	Unit	Control mode			
				PT	PR	S	T
P1.015	E-Cam: filter setting for synchronous Capture axis correction	0x0000	-	-	O	-	-
P1.016■	E-Cam: error offset compensation for synchronous Capture axis	0	Pulse unit of master axis	-	O	-	-
P1.018	E-Cam: compensation time for the pulse of E-Cam master axis	0	ms	-	O	-	-
P1.021	E-Cam: minimum frequency of pulse compensation for the E-Cam master axis	0	Kpps	-	O	-	-
P2.073	E-Cam: phase alignment operation setting	0x00000000	-	-	O	-	-
P2.074	E-Cam: DI delay time for phase alignment	0.000	ms	-	O	-	-
P2.075■	E-Cam: target position for phase alignment	0	Pulse unit of master axis	-	O	-	-
P2.076■	E-Cam: phase alignment control switch	0x0000	-	-	O	-	-
P2.077■	E-Cam: pulse masking and virtual pulse for master axis	0x0000	-	-	O	-	-
P2.078	E-Cam: DO.CAM_AREA2 rising-edge phase	270	Degree	-	O	-	-
P2.079	E-Cam: DO.CAM_AREA2 falling-edge phase	360	Degree	-	O	-	-
P5.019	E-Cam: curve scaling	1.000000	0.000001 times	-	O	-	-
P5.077■	E-Cam: position for synchronous Capture axis	0	Pulse unit of master axis	-	O	-	-
P5.078	E-Cam: interval between each synchronous Capture action	100	Pulse unit of master axis	-	O	-	-
P5.079■	E-Cam: pulse error for synchronous Capture axis	0	Pulse unit of master axis	-	O	-	-
P5.080	E-Cam: maximum correction rate for synchronous Capture axis	10	%	-	O	-	-
P5.081	E-Cam: start address for data array	100	-	-	O	-	-
P5.082	E-Cam: segment number (N)	5	-	-	O	-	-
P5.083	E-Cam: master gear ratio setting - cycle number (M)	1	-	-	O	-	-
P5.084	E-Cam: master gear ratio setting - pulse number (P)	3600	-	-	O	-	-
P5.085	E-Cam: engaged segment number	0	-	-	O	-	-
P5.086■	E-Cam: master axis position	0	Pulse unit of master axis	-	O	-	-
P5.087	E-Cam: initial lead pulse before engaged	0	Pulse unit of master axis	-	O	-	-
P5.088■	E-Cam: activate E-Cam control	0x00000000	-	-	O	-	-
P5.089	E-Cam: pulse number upon disengagement	0	Pulse unit of master axis	-	O	-	-
P5.090	E-Cam: DO.CAM_AREA1 rising-edge phase	270	Degree	-	O	-	-

8

Parameter No.	Function	Default value	Unit	Control mode			
				PT	PR	S	T
P5.091	E-Cam: DO.CAM_AREA1 falling-edge phase	360	Degree	-	O	-	-
P5.092	E-Cam: pre-engaged pulse number for each cycle	0	Pulse unit of master axis	-	O	-	-
P5.093	Motion control macro command: command parameter #4	0x00000000	-	O	O	O	O
P5.094	Motion control macro command: command parameter #3	0	-	O	O	O	O
P5.095	Motion control macro command: command parameter #2	0	-	O	O	O	O
P5.096	Motion control macro command: command parameter #1	0	-	O	O	O	O
P5.097■	Motion control macro command: issue command / read execution result	0x0000	-	O	O	O	O

- (★) Read-only parameter. Can only read the value of the parameter. For example, P0.000, P0.010, and P4.001.
- (▲) Parameter cannot be changed when servo is in Servo On status. For example, P1.000 and P1.046.
- (●) Parameter changes become valid after power cycling. For example, P1.001 and P3.000.
- (■) Parameter resets to its default value after power cycling. For example, P3.006.

**Special function parameters**

Parameter No.	Function	Default value	Unit	Control mode			
				PT	PR	S	T
P1.060	Motor hard stop 1 - level offset	0	%	O	O	O	O
P1.105	Motor hard stop 2 - torque upper limit	0	%	O	O	O	O
P1.106	Motor hard stop 2 - torque lower limit	0	%	O	O	O	O
P1.120	STO deactivation settings	3	-	O	O	O	O
P2.081	Pulse leakage detection function	1	-	O	O	O	O
P2.082	Pulse leakage warning level	400	pulse	O	O	O	O
P2.083	Exceed Z signal detection	2000	pulse	O	O	O	O

- (★) Read-only parameter. Can only read the value of the parameter. For example, P0.000, P0.010, and P4.001.
- (▲) Parameter cannot be changed when servo is in Servo On status. For example, P1.000 and P1.046.
- (●) Parameter changes become valid after power cycling. For example, P1.001 and P3.000.
- (■) Parameter resets to its default value after power cycling. For example, P3.006.

## Motor parameters

Parameter No.	Function	Default value	Unit	Applicable motor		
				Linear motor	Rotary motor	-
PM.000▲●	Motor type	0	-	<input type="radio"/>	<input type="radio"/>	-
PM.001▲■	Motor parameter automatic identification function	0	-	<input type="radio"/>	<input type="radio"/>	-
PM.002▲●	Motor parameter identification status	0	-	<input type="radio"/>	<input type="radio"/>	-
PM.003▲●	Encoder type	0x0010	-	<input type="radio"/>	<input type="radio"/>	-
PM.004▲●	Main encoder resolution	-	Refer to the description of PM.004.	<input type="radio"/>	<input type="radio"/>	-
PM.005	Position signal converter box interpolation magnification	11	-	<input type="radio"/>	<input type="radio"/>	-
PM.006▲●	Motor UVW and Hall sensor phase sequences	0x0000	-	<input type="radio"/>	<input type="radio"/>	-
PM.007▲●	Hall sensor offset angle	0.0	Degree	<input type="radio"/>	<input type="radio"/>	-
PM.008▲●	Hall sensor hysteresis width	0.0	Degree	<input type="radio"/>	<input type="radio"/>	-
PM.009▲	Electrical angle settings	0x0000	-	<input type="radio"/>	<input type="radio"/>	-
PM.010▲●	Offset between absolute encoder zero point and motor magnetic field zero point	180.0	Degree	<input type="radio"/>	<input type="radio"/>	-
PM.011▲	Current setting for initial magnetic field detection	100	%	<input type="radio"/>	<input type="radio"/>	-
PM.012▲	Initial magnetic field detection	0x0044	-	<input type="radio"/>	<input type="radio"/>	-
PM.013▲●	Motor flag	0	-	<input type="radio"/>	<input type="radio"/>	-
PM.015	Current loop proportional gain (kp)	0.000 (panel / software)	1 rad/s (panel / software)	<input type="radio"/>	<input type="radio"/>	-
		0 (communication)	0.001 rad/s (communication)			
PM.016	Current loop integral gain (ki)	0	%	<input type="radio"/>	<input type="radio"/>	-
PM.019▲	Load increase gain	100	%	<input type="radio"/>	<input type="radio"/>	-
PM.020▲	Load decrease gain	100	%	<input type="radio"/>	<input type="radio"/>	-
PM.022▲●	Motor temperature sensor	0	-	<input type="radio"/>	<input type="radio"/>	-
PM.024▲	Motor temperature sensor resistance	50000	ohm	<input type="radio"/>	<input type="radio"/>	-
PM.028▲●	Permanent-magnet rotary motor pole number	10	pole	-	<input type="radio"/>	-
PM.029▲●	Permanent-magnet rotary motor rated current	- (panel / software)	Arms (panel / software)	-	<input type="radio"/>	-
		- (communication)	0.01 Arms (communication)			
PM.030▲●	Permanent-magnet rotary motor maximum current	- (panel / software)	Arms (panel / software)	-	<input type="radio"/>	-
		- (communication)	0.01 Arms (communication)			
PM.031▲	Permanent-magnet rotary motor rated speed	-	rpm	-	<input type="radio"/>	-
PM.032▲	Permanent-magnet rotary motor maximum speed	-	rpm	-	<input type="radio"/>	-

Parameter No.	Function	Default value	Unit	Applicable motor		
				Linear motor	Rotary motor	-
PM.033 ▲	Permanent-magnet rotary motor torque constant	- (panel / software)	Nm/Arms (panel / software)	-	○	-
		- (communication)	0.001 Nm/Arms (communication)			
PM.034 ▲	Permanent-magnet rotary motor rotor inertia	- (panel / software)	$10^{-4}$ kg·m <sup>2</sup> (panel / software)	-	○	-
		- (communication)	$0.001 \cdot 10^{-4}$ kg·m <sup>2</sup> (communication)			
PM.035 ▲	Permanent-magnet rotary motor phase resistance	- (panel / software)	ohm (panel / software)	-	○	-
		- (communication)	0.001 ohm (communication)			
PM.036 ▲	Permanent-magnet rotary motor phase inductance	- (panel / software)	mH (panel / software)	-	○	-
		- (communication)	0.01 mH (communication)			
PM.038 ▲	Permanent-magnet rotary motor back electromotive force constant	- (panel / software)	Vrms/rpm (communication)	-	○	-
		- (communication)	0.0001 Vrms/rpm (communication)			
PM.045 ▲●	Linear motor pole pitch (N-N)	- (panel / software)	mm/360° (mm/N-N) (communication)	○	-	-
		- (communication)	0.001 mm/360° (0.001 mm/N-N) (communication)			
PM.046 ▲●	Linear motor rated current	- (panel / software)	Arms (panel / software)	○	-	-
		- (communication)	0.01 Arms (communication)			
PM.047 ▲●	Linear motor maximum current	- (panel / software)	Arms (panel / software)	○	-	-
		- (communication)	0.01 Arms (communication)			
PM.048 ▲	Linear motor maximum speed	-	mm/s	○	-	-
PM.049 ▲	Linear motor force constant	- (panel / software)	N/Arms (communication)	○	-	-
		- (communication)	0.01 N/Arms (communication)			
PM.050 ▲	Linear motor phase resistance	- (panel / software)	ohm (panel / software)	○	-	-
		- (communication)	0.001 ohm (communication)			

## 8

Parameter No.	Function	Default value	Unit	Applicable motor		
				Linear motor	Rotary motor	-
PM.051▲	Linear motor phase inductance	- (panel / software)	mH (panel / software)	○	-	-
		- (communication)	0.01 mH (communication)			
PM.053▲	Linear motor back electromotive force constant	- (panel / software)	Vrms/(m/s) (panel / software)	○	-	-
		- (communication)	0.1 Vrms/(m/s) (communication)			

- (★) Read-only parameter. Can only read the value of the parameter. For example, P0.000, P0.010, and P4.001.
- (▲) Parameter cannot be changed when servo is in Servo On status. For example, P1.000 and P1.046.
- (●) Parameter changes become valid after power cycling. For example, P1.001 and P3.000.
- (■) Parameter resets to its default value after power cycling. For example, P3.006.

### 8.3 Parameter descriptions

#### P0.xxx Monitoring parameters

P0.000★	Firmware version		Address: 0000H 0001H
Default:	Factory setting	Control mode:	All
Unit:	-	Setting range:	-
Format:	DEC	Data size:	16-bit

Settings:

Displays the firmware version of the servo drive.

P0.001■	Current drive alarm code (seven-segment display)		Address: 0002H 0003H
Default:	-	Control mode:	All
Unit:	-	Setting range:	0x0000: alarm clear (same as DI.ARST). 0x0001 - 0xFFFF: displays the alarm code (not writable).
Format:	HEX	Data size:	16-bit

Settings:

For the list of alarms, refer to Section 14.1 Alarm list.

P0.002	Drive status		Address: 0004H 0005H
Default:	1	Control mode:	All
Unit:	-	Setting range:	-300 to +127
Format:	DEC	Data size:	16-bit

Settings:

Input the monitoring code to P0.002 to view changes to the variable on the panel. For the list of monitoring variables, refer to Table 8.3 Monitoring variables descriptions.

P0.003	Analog output monitoring		Address: 0006H 0007H
Default:	0x0000	Control mode:	All
Unit:	-	Setting range:	0x0000 to 0x0077
Format:	HEX	Data size:	16-bit

Settings:

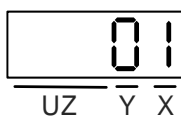



8

X	MON2	UZ	Reserved
Y	MON1	-	-

MON1 and MON2 set value	Description	MON1 and MON2 set value	Description
0	Motor speed (+/- 8 volts / Maximum speed)	4	Torque command (+/- 8 volts / Maximum Torque command)
1	Motor torque (+/- 8 volts / Maximum torque)	5	VBUS voltage (+/- 8 volts / 450V)
2	Pulse command frequency (+8 volts / 4.5 Mpps)	6	Analog output voltage is the set value of P1.101
3	Speed command (+/- 8 volts / Maximum Speed command)	7	Analog output voltage is the set value of P1.102

Note: refer to P1.004 and P1.005 for the proportional setting for the analog output voltage.

For example: when you set P0.003 to 01 (MON1 is the analog output of motor speed; MON2 is the analog output of motor torque):

$$\text{MON1 output voltage} = 8 \times \frac{\text{Motor speed}}{(\text{Maximum speed} \times \frac{P1.004}{100})} \text{ (Unit: volts)}$$

$$\text{MON2 output voltage} = 8 \times \frac{\text{Motor torque}}{(\text{Maximum torque} \times \frac{P1.005}{100})} \text{ (Unit: volts)}$$

<b>P0.004 - P0.007</b>	<b>Reserved</b>
------------------------	-----------------

<b>P0.008★</b>	<b>Total servo drive operation time</b>	<b>Address: 0010H 0011H</b>	
Default:	0x00000000	Control mode:	All
Unit:	hour	Setting range:	0x00000000 - 0xFFFFFFFF
Format:	HEX	Data size:	32-bit

Settings:

Displays the total servo drive operation and Servo On time. The unit is in hours and durations of less than 1 hour are not recorded. The recorded hours are saved when the servo power is off.



DCBA	Servo On time	UZ YX	Servo power applied time
------	---------------	-------	--------------------------

<b>P0.009★■</b>	<b>Status monitoring register 1</b>		<b>Address: 0012H 0013H</b>
Default:	-	Control mode:	All
Unit:	-	Setting range:	-
Format:	DEC	Data size:	32-bit

## Settings:

Set the value to be monitored in P0.017 through the drive panel or communication. Please refer to P0.002. The communication port reads the communication address to get the status.

For example, if you set P0.017 to 3 to access P0.009, the panel displays the total number of feedback pulses of the motor encoder. If accessing the data through Modbus communication, it reads two 16-bit values (0012H and 0013H) as a single 32-bit value. (0013H : 0012H) = (High word : Low word). Set P0.002 to 23 and the panel displays "VAR-1" and then the value of P0.009.

<b>P0.010★■</b>	<b>Status monitoring register 2</b>		<b>Address: 0014H 0015H</b>
Default:	-	Control mode:	All
Unit:	-	Setting range:	-
Format:	DEC	Data size:	32-bit

## Settings:

Set the value to be monitored in P0.018 through the drive panel or communication. Please refer to P0.002. To get the status, read the communication address through the communication port. Set P0.002 to 24 and the panel displays "VAR-2" and then the value of P0.010.

<b>P0.011★■</b>	<b>Status monitoring register 3</b>		<b>Address: 0016H 0017H</b>
Default:	-	Control mode:	All
Unit:	-	Setting range:	-
Format:	DEC	Data size:	32-bit

## Settings:

Set the value to be monitored in P0.019 through the drive panel or communication. Please refer to P0.002. To get the status, read the communication address through the communication port. Set P0.002 to 25 and the panel displays "VAR-3" and then the value of P0.011.

## 8

<b>P0.012★■</b>	<b>Status monitoring register 4</b>		<b>Address: 0018H 0019H</b>
Default:	-	Control mode:	All
Unit:	-	Setting range:	-
Format:	DEC	Data size:	32-bit

Settings:

Set the value to be monitored in P0.020 through the drive panel or communication. Please refer to P0.002. To get the status, read the communication address through the communication port. Set P0.002 to 26 and the panel displays “VAR-4” and then the value of P0.012.

<b>P0.013★■</b>	<b>Status monitoring register 5</b>		<b>Address: 001AH 001BH</b>
Default:	-	Control mode:	All
Unit:	-	Setting range:	-
Format:	DEC	Data size:	32-bit

Settings:

Set the value to be monitored in P0.021 through the drive panel or communication. Please refer to P0.002. To get the status, read the communication address through the communication port.

<b>P0.014 - P0.016</b>	<b>Reserved</b>
----------------------------	-----------------

<b>P0.017</b>	<b>Select content displayed by status monitoring register 1</b>		<b>Address: 0022H 0023H</b>
Default:	0	Control mode:	All
Unit:	-	Setting range:	-300 to +127
Format:	DEC	Data size:	16-bit

Settings:

Refer to Table 8.3 for the available values.

For example, if you set P0.017 to 7, then reading P0.009 displays the motor speed (0.1 rpm) at present.

<b>P0.018</b>	<b>Select content displayed by status monitoring register 2</b>		<b>Address: 0024H 0025H</b>
Default:	0	Control mode:	All
Unit:	-	Setting range:	-300 to +127
Format:	DEC	Data size:	16-bit

Settings:

Refer to Table 8.3 for the available values.

<b>P0.019</b>	<b>Select content displayed by status monitoring register 3</b>		<b>Address: 0026H 0027H</b>
Default:	0	Control mode:	All
Unit:	-	Setting range:	-300 to +127
Format:	DEC	Data size:	16-bit

Settings:

Refer to Table 8.3 for the available values.

<b>P0.020</b>	<b>Select content displayed by status monitoring register 4</b>		<b>Address: 0028H 0029H</b>
Default:	0	Control mode:	All
Unit:	-	Setting range:	-300 to +127
Format:	DEC	Data size:	16-bit

Settings:

Refer to Table 8.3 for the available values.

<b>P0.021</b>	<b>Select content displayed by status monitoring register 5</b>		<b>Address: 002AH 002BH</b>
Default:	0	Control mode:	All
Unit:	-	Setting range:	-300 to +127
Format:	DEC	Data size:	16-bit

Settings:

Refer to Table 8.3 for the available values.

<b>P0.022 - P0.024</b>	<b>Reserved</b>		
----------------------------	-----------------	--	--

<b>P0.025■</b>	<b>Mapping parameter 1</b>		<b>Address: 0032H 0033H</b>
Default:	-	Control mode:	All
Unit:	-	Setting range:	Determined by the corresponding parameter P0.035
Format:	HEX	Data size:	32-bit

Settings:

You can continuously read and write parameters faster if they are not in the same group. Use P0.035 to specify the parameter number to be read or written with the mapping parameter through the panel or communication. The value of the parameter that is specified by P0.035 is shown in P0.025. Refer to P0.035 for its settings.

8

<b>P0.026</b>	<b>Mapping parameter 2</b>		<b>Address: 0034H 0035H</b>
Default:	-	Control mode:	All
Unit:	-	Setting range:	Determined by the corresponding parameter P0.036
Format:	HEX	Data size:	32-bit

Settings:

This setting is the same as P0.025, except its mapping target is set in P0.036.

<b>P0.027</b>	<b>Mapping parameter 3</b>		<b>Address: 0036H 0037H</b>
Default:	-	Control mode:	All
Unit:	-	Setting range:	Determined by the corresponding parameter P0.037
Format:	HEX	Data size:	32-bit

Settings:

This setting is the same as P0.025, except its mapping target is set in P0.037.

<b>P0.028</b>	<b>Mapping parameter 4</b>		<b>Address: 0038H 0039H</b>
Default:	-	Control mode:	All
Unit:	-	Setting range:	Determined by the corresponding parameter P0.038
Format:	HEX	Data size:	32-bit

Settings:

This setting is the same as P0.025, except its mapping target is set in P0.038.

<b>P0.029</b>	<b>Mapping parameter 5</b>		<b>Address: 003AH 003BH</b>
Default:	-	Control mode:	All
Unit:	-	Setting range:	Determined by the corresponding parameter P0.039
Format:	HEX	Data size:	32-bit

Settings:

This setting is the same as P0.025, except its mapping target is set in P0.039.

<b>P0.030</b>	<b>Mapping parameter 6</b>		<b>Address: 003CH 003DH</b>
Default:	-	Control mode:	All
Unit:	-	Setting range:	Determined by the corresponding parameter P0.040
Format:	HEX	Data size:	32-bit

Settings:

This setting is the same as P0.025, except its mapping target is set in P0.040.

<b>P0.031</b>	<b>Mapping parameter 7</b>		<b>Address: 003EH 003FH</b>
Default:	-	Control mode:	All
Unit:	-	Setting range:	Determined by the corresponding parameter P0.041
Format:	HEX	Data size:	32-bit

Settings:

This setting is the same as P0.025, except its mapping target is set in P0.041.

<b>P0.032</b>	<b>Mapping parameter 8</b>		<b>Address: 0040H 0041H</b>
Default:	-	Control mode:	All
Unit:	-	Setting range:	Determined by the corresponding parameter P0.042
Format:	HEX	Data size:	32-bit

Settings:

This setting is the same as P0.025, except its mapping target is set in P0.042.

<b>P0.033 - P0.034</b>	<b>Reserved</b>		
----------------------------	-----------------	--	--

<b>P0.035</b>	<b>Target setting for mapping parameter P0.025</b>		<b>Address: 0046H 0047H</b>
Default:	-	Control mode:	All
Unit:	-	Setting range:	Determined by the communication address of the parameter group
Format:	HEX	Data size:	32-bit

Settings:

The formats of parameter High Word (PH) and parameter Low Word (PL) are:



BA	Hexadecimal code for the parameter index	YX	Hexadecimal code for the parameter index
C	Hexadecimal code for the parameter group	Z	Hexadecimal code for the parameter group
D	N/A	U	N/A

8

Select the corresponding parameter(s) for the data block access register 1 (P0.035). The mapping value is 32 bits and can map to two 16-bit parameters or one 32-bit parameter.

P0.035: (Parameter to be mapped: P0.035; Content of mapping parameter: P0.025)

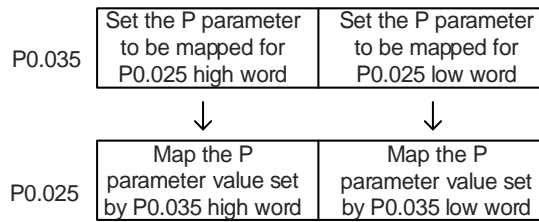

1. When PH ≠ PL, it indicates that the content of P0.025 includes two 16-bit parameters.

Example: Target: set P2.003 to 0 and P2.005 to 100 through the mapping parameter.

Setting: set the P0.035 high word to 0203 (P2.003) and low word to 0205 (P2.005).

Thus, P0.035 = 0x02030205.

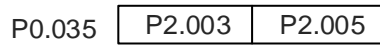

Write: set 0x00050064 to the mapping parameter P0.025, and the values of P2.003 and P2.005 are:

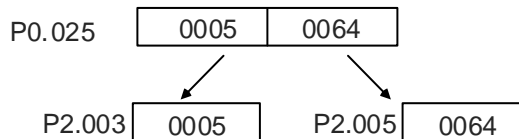

2. When PH = PL = P, it indicates that the content of P0.025 includes one 32-bit parameter.

Example: Target: set P6.010 to 0x00050064 through the mapping parameter.

Setting: set both the high word and low word of P0.035 to 060A (P6.010).

Thus, P0.035 = 0x060A060A.

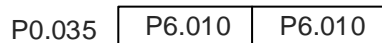

Write: set 0x00050064 to the mapping parameter P0.025, and P6.010 changes immediately.





8

<b>P0.039</b>	<b>Target setting for mapping parameter P0.029</b>		<b>Address: 004EH 004FH</b>
Default:	-	Control mode:	All
Unit:	-	Setting range:	Determined by the communication address of the parameter group
Format:	HEX	Data size:	32-bit

Settings:

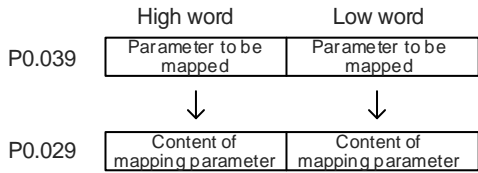

<b>P0.040</b>	<b>Target setting for mapping parameter P0.030</b>		<b>Address: 0050H 0051H</b>
Default:	-	Control mode:	All
Unit:	-	Setting range:	Determined by the communication address of the parameter group
Format:	HEX	Data size:	32-bit

Settings:

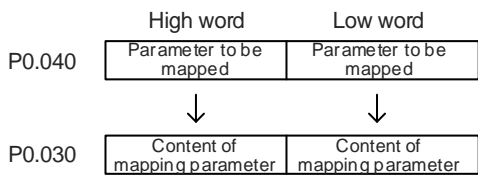

<b>P0.041</b>	<b>Target setting for mapping parameter P0.031</b>		<b>Address: 0052H 0053H</b>
Default:	-	Control mode:	All
Unit:	-	Setting range:	Determined by the communication address of the parameter group
Format:	HEX	Data size:	32-bit

Settings:

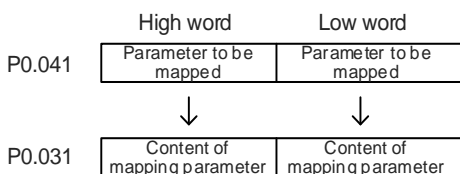

<b>P0.042</b>	<b>Target setting for mapping parameter P0.032</b>		<b>Address: 0054H 0055H</b>
Default:	-	Control mode:	All
Unit:	-	Setting range:	Determined by the communication address of the parameter group
Format:	HEX	Data size:	32-bit

Settings:

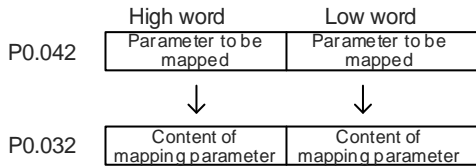

<b>P0.043</b>	<b>Reserved</b>		
---------------	-----------------	--	--

<b>P0.044★■</b>	<b>Status monitoring register (for PC software)</b>		<b>Address: 0058H 0059H</b>
Default:	0	Control mode:	All
Unit:	-	Setting range:	Determined by the communication address of the parameter group
Format:	DEC	Data size:	32-bit

Settings:

This setting is the same as P0.009.

<b>P0.045■</b>	<b>Status monitoring register content selection (for PC software)</b>		<b>Address: 005AH 005BH</b>
Default:	0	Control mode:	All
Unit:	-	Setting range:	-300 to +127
Format:	DEC	Data size:	16-bit

Settings:

This setting is the same as P0.017.

8

<b>P0.046★</b>	<b>Servo drive digital output (DO) status</b>		<b>Address: 005CH 005DH</b>
Default:	0x0000	Control mode:	All
Unit:	-	Setting range:	0x0000 - 0x00FF
Format:	HEX	Data size:	16-bit

Settings:

Bit	Function	Bit	Function
0	SRDY (servo ready)	8	HOME (homing complete)
1	SON (Servo On)	9	OLW (early warning for motor overload)
2	ZSPD (zero speed detection)	10	WARN (Servo warning, CW, CCW, EMGS, undervoltage, or communication error)
3	TSPD (target speed reached)	11	Reserved
4	TPOS (target position reached)	12	Reserved
5	TQL (torque limit activated)	13	Reserved
6	ALRM (servo alarm)	14	Reserved
7	BRKR (magnetic brake control output)	15	Reserved

<b>P0.047 - P0.048</b>	<b>Reserved</b>
------------------------	-----------------

<b>P0.049</b>	<b>Update encoder absolute position</b>		<b>Address: 0062H 0063H</b>
Default:	0x0000	Control mode:	All
Unit:	-	Setting range:	0x0000 - 0x0002
Format:	HEX	Data size:	16-bit

Settings:



U Z Y X

X	Command processing	Z	Reserved
Y	Reserved	U	Reserved

■ X: command processing

0: N/A

1: update the encoder data of P0.050 - P0.052.

2: update P0.050 - P0.052 and clear the position error. When this command takes effect, the motor's current position is set to the terminal point of the Position command.

<b>P0.050★■</b>	<b>Absolute position system status</b>		<b>Address: 0064H 0065H</b>
Default:	0x0000	Control mode:	All
Unit:	-	Setting range:	0x0000 - 0x001F
Format:	HEX	Data size:	16-bit

Settings:

Bit	7	6	5	4	3	2	1	0
-----	---	---	---	---	---	---	---	---

Bit	15	14	13	12	11	10	9	8
-----	----	----	----	----	----	----	---	---

Bit	Function	Description
Bit 0	Absolute position status	0: normal. 1: lost.
Bit 1	Battery voltage status	0: normal. 1: undervoltage.
Bit 2	Status of absolute number of turns	0: normal. 1: overflows.
Bit 3	PUU status	0: normal. 1: overflows.
Bit 4	Absolute position status	0: established. 1: not yet established.
Bit 5 - Bit 15	Reserved	-

<b>P0.051★■</b>	<b>Encoder absolute position - number of revolutions</b>		<b>Address: 0066H 0067H</b>
Default:	0	Control mode:	All
Unit:	rev	Setting range:	-32768 to +32767
Format:	DEC	Data size:	16-bit

Settings:

When you set P2.070 [Bit 1] to 1 for reading the pulse number, this parameter displays the encoder's absolute position in the form of number of revolutions. When you set P2.070 [Bit 1] to 0 for reading the PUU number, this parameter becomes invalid and the panel displays 0.

<b>P0.052★■</b>	<b>Encoder absolute position - pulse number within single turn or PUU</b>		<b>Address: 0068H 0069H</b>
Default:	0	Control mode:	All
Unit:	pulse or PUU	Setting range:	0 to 16777216-1 (pulse) -2147483648 to +2147483647 (PUU)
Format:	DEC	Data size:	32-bit

Settings:

When you set P2.070 [Bit 1] to 1 for reading the pulse number, this parameter displays the encoder's absolute position in the form of pulse number within a single turn. When you set P2.070 [Bit 1] to 0 for reading the PUU number, this parameter displays the motor's absolute position in PUU.

8

<b>P0.053</b>	<b>General range compare digital output - filter time</b>		<b>Address: 006AH 006BH</b>
Default:	0x0000	Control mode:	All
Unit:	-	Setting range:	0x0000 - 0xFFFF
Format:	HEX	Data size:	16-bit

Settings:



X	First filter time	Z	Third filter time
Y	Second filter time	U	Fourth filter time

Note: the minimum filter time is 1 ms (set value 0 = 1 ms; 1 = 2 ms; 2 = 3 ms; ...; F = 16 ms).

Example of the first filter:

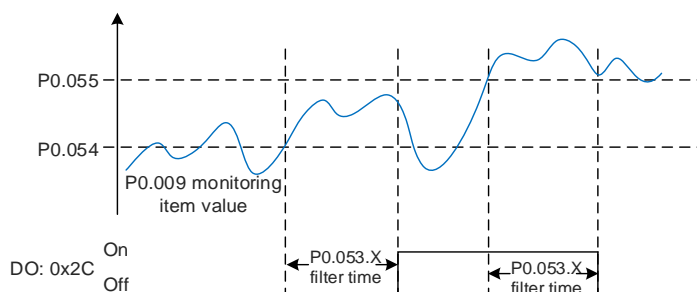

<b>P0.054</b>	<b>General range compare digital output 1 - lower limit</b>		<b>Address: 006CH 006DH</b>
Default:	0	Control mode:	All
Unit:	-	Setting range:	-2147483648 to +2147483647
Format:	DEC	Data size:	32-bit

Settings:

Before using this function, set the digital output function to 0x2C (first set of general range comparison) and the monitoring item of P0.017.

When the monitoring item value of P0.009 is within the range set by P0.054 and P0.055, and after the filter time set by P0.053.X, this digital output is on.

<b>P0.055</b>	<b>General range compare digital output 1 - upper limit</b>		<b>Address: 006EH 006FH</b>
Default:	0	Control mode:	All
Unit:	-	Setting range:	-2147483648 to +2147483647
Format:	DEC	Data size:	32-bit

Settings:

Refer to the description of P0.054.

<b>P0.056</b>	<b>General range compare digital output 2 - lower limit</b>		<b>Address: 0070H 0071H</b>
Default:	0	Control mode:	All
Unit:	-	Setting range:	-2147483648 to +2147483647
Format:	DEC	Data size:	32-bit

## Settings:

Before using this function, set the digital output function to 0x2D (second set of general range comparison) and the monitoring item of P0.018.

When the monitoring item value of P0.010 is within the range set in P0.056 and P0.057, and after the filter time set by P0.053.Y, this digital output is on.

<b>P0.057</b>	<b>General range compare digital output 2 - upper limit</b>		<b>Address: 0072H 0073H</b>
Default:	0	Control mode:	All
Unit:	-	Setting range:	-2147483648 to +2147483647
Format:	DEC	Data size:	32-bit

## Settings:

Refer to the description of P0.056.

<b>P0.058</b>	<b>General range compare digital output 3 - lower limit</b>		<b>Address: 0074H 0075H</b>
Default:	0	Control mode:	All
Unit:	-	Setting range:	-2147483648 to +2147483647
Format:	DEC	Data size:	32-bit

## Settings:

Before using this function, set the digital output function to 0x2E (third set of general range comparison) and the monitoring item of P0.019.

When the monitoring item value of P0.011 is within the range set in P0.058 and P0.059, and after the filter time set by P0.053.Z, this digital output is on.

<b>P0.059</b>	<b>General range compare digital output 3 - upper limit</b>		<b>Address: 0076H 0077H</b>
Default:	0	Control mode:	All
Unit:	-	Setting range:	-2147483648 to +2147483647
Format:	DEC	Data size:	32-bit

## Settings:

Refer to the description of P0.058.

## 8

<b>P0.060</b>	<b>General range compare digital output 4 - lower limit</b>		<b>Address: 0078H 0079H</b>
Default:	0	Control mode:	All
Unit:	-	Setting range:	-2147483648 to +2147483647
Format:	DEC	Data size:	32-bit

Settings:

Before using this function, set the digital output function to 0x2F (fourth set of general range comparison) and the monitoring item of P0.020.

When the monitoring item value of P0.012 is within the range set in P0.060 and P0.061, and after the filter time set by P0.053.U, this digital output is on.

<b>P0.061</b>	<b>General range compare digital output 4 - upper limit</b>		<b>Address: 007AH 007BH</b>
Default:	0	Control mode:	All
Unit:	-	Setting range:	-2147483648 to +2147483647
Format:	DEC	Data size:	32-bit

Settings:

Refer to the description of P0.060.

<b>P0.062</b>	<b>Reserved</b>		
---------------	-----------------	--	--

<b>P0.063★</b>	<b>Total duration of DC Bus voltage exceeding 400V or 800V</b>		<b>Address: 007EH 007FH</b>
Default:	0	Control mode:	All
Unit:	ms	Setting range:	0 - 2147483647
Format:	DEC	Data size:	32-bit

Settings:

220V models: records the total time during which the voltage of the DC Bus exceeded 400V.

400V models: records the total time during which the voltage of the DC Bus exceeded 800V.

<b>P0.064 - P0.078</b>	<b>Reserved</b>		
----------------------------	-----------------	--	--

<b>P0.079★</b>	<b>IGBT highest temperature</b>		<b>Address: 009EH 009FH</b>
Default:	0	Control mode:	All
Unit:	°C	Setting range:	0 - 2147483647
Format:	DEC	Data size:	32-bit

Settings:

Records the highest IGBT temperature.

<b>P0.080 - P0.100</b>	<b>Reserved</b>
----------------------------	-----------------

8



8

**P1.xxx Basic parameters**

<b>P1.000 ▲</b>	<b>External pulse input type</b>		<b>Address: 0100H 0101H</b>
Default:	0x1042	Control mode:	PT
Unit:	-	Setting range:	0x0000 - 0x11F2
Format:	HEX	Data size:	16-bit

Settings:



U Z Y X

X	Pulse type	Z	Logic type
Y	Filter width	U	Filter width

- X: pulse type
  - 0: A phase + B phase
  - 1: clockwise and counterclockwise pulses
  - 2: pulse train + sign
  - Others: reserved
- Z: logic type
  - 0: positive logic
  - 1: negative logic

Digital circuits use 0 and 1 to represent the high and low voltage levels. In positive logic, 1 represents high voltage and 0 represents low voltage; in negative logic, 1 represents low voltage and 0 represents high voltage.

Example:

Positive logic

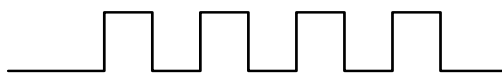

Negative logic

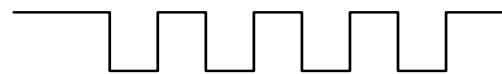

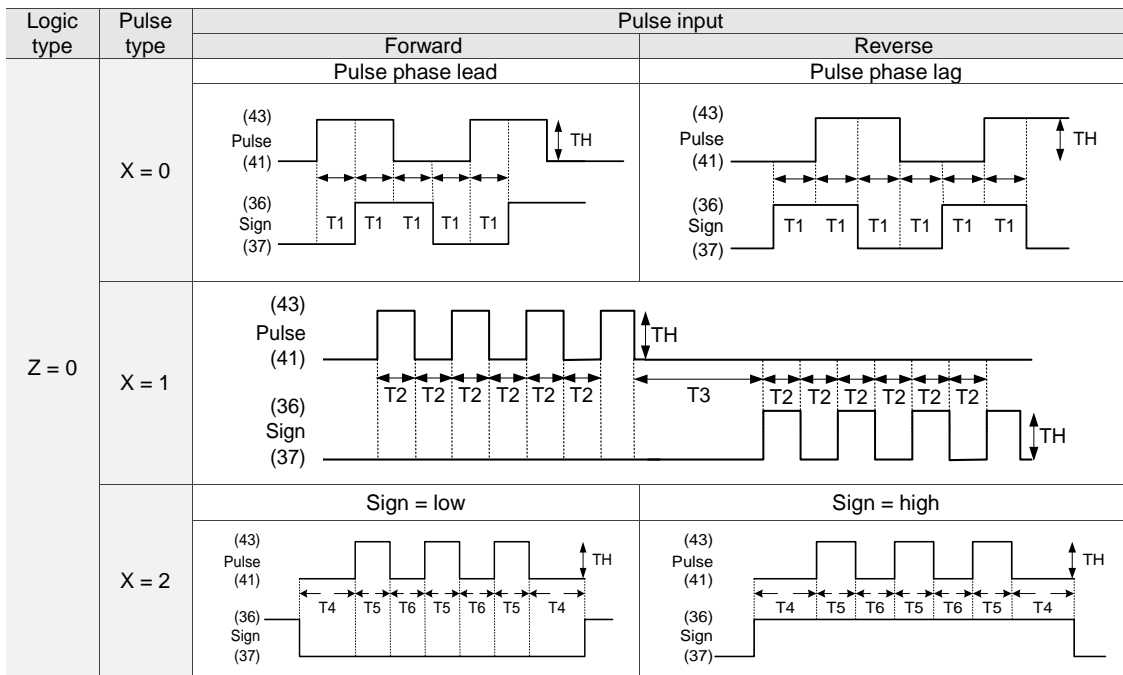

Pulse specification		Maximum input frequency (single phase)	Minimum allowed time width					
			T1	T2	T3	T4	T5	T6
Differential signal	Pulse train + sign	4 Mpps	62.5 ns	125 ns	250 ns	200 ns	125 ns	125 ns
	CW and CCW pulses							
	A phase + B phase	2 Mpps	125 ns	250 ns	250 ns	200 ns	250 ns	250 ns
Open-collector		200 Kpps	1.25 μs	2.5 μs	5 μs	5 μs	2.5 μs	2.5 μs

Definition	Parameter settings	Pulse specification		Maximum input frequency (single phase)	Voltage	Forward current
High speed pulse	Refer to the U & Y settings in the following table	Differential signal	Pulse train + sign	4 Mpps	5V	< 25 mA
			CW and CCW pulses			
			A phase + B phase	2 Mpps		
		Open-collector		200 Kpps	24V (Max.)	< 25 mA
Low speed pulse <sup>Note</sup>	U = 2 and Y = 0	Differential signal		200 Kpps	5V	< 25 mA
		Open-collector		200 Kpps	24V (Max.)	< 25 mA

Note:

1. When the low speed pulse is used (U = 2), parameter Y has to be 0 (no filter function).
2. It is suggested that you use the low speed pulse function when there is high frequency interference.
3. Contact Delta for the week for introducing the low speed pulse function to the servo drive.

8

■ U, Y: filter width

If the pulse frequency is suddenly too high, causing a pulse width smaller than the set filter width, then this pulse gets filtered out as noise. Therefore, set the filter width smaller than the actual pulse width. You should set the filter width as 4 times smaller than the actual pulse width.

U and Y values	Filter width Unit: $\mu\text{s}$ (kHz)	U and Y values	Filter width Unit: $\mu\text{s}$ (kHz)
0, 0	No filter function	1, 0	No filter function
0, 1	2 (250)	1, 1	0.2 (2500)
0, 2	3 (166)	1, 2	0.3 (1666)
0, 3	4 (125)	1, 3	0.4 (1250)
0, 4	5 (100)	1, 4	0.5 (1000)
0, 5	6 (83)	1, 5	0.6 (833)
0, 6	7 (71)	1, 6	0.7 (714)
0, 7	8 (62)	1, 7	0.8 (625)
0, 8	9 (55)	1, 8	0.9 (555)
0, 9	10 (50)	1, 9	1 (500)
0, A	11 (45)	1, A	1.1 (454)
0, B	12 (41)	1, B	1.2 (416)
0, C	13 (38)	1, C	1.3 (384)
0, D	14 (35)	1, D	1.4 (357)
0, E	15 (33)	1, E	1.5 (333)

Example:

When U is set to 1 and Y is set to 1 (and filter width is therefore  $0.2 \mu\text{s}$ ), and when the high and low duty width of the command pulse are both larger than  $0.8 \mu\text{s}$  (and filter width is 4 times  $0.2 \mu\text{s}$ ), then the pulse command is not filtered out.

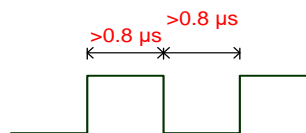

When the high or low duty width of the pulse is smaller than the filter width, then it is filtered out.

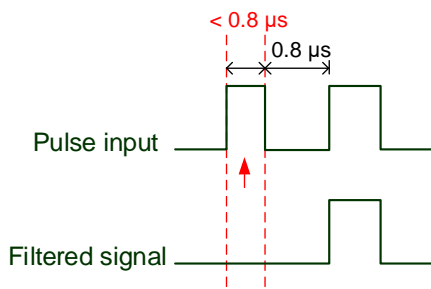

If the first pulse width is smaller than  $0.8 \mu\text{s}$ , the pulse may be filtered out, and thus two input pulses will be regarded as one pulse. If the pulse width is smaller than  $0.2 \mu\text{s}$ , the pulse will be filtered out.

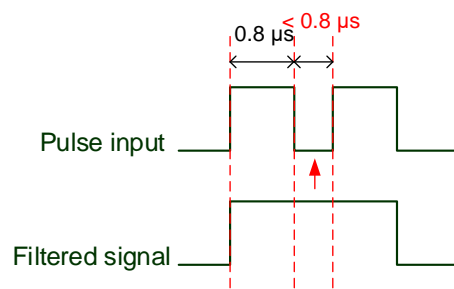

If the low level pulse width is smaller than  $0.8 \mu\text{s}$ , the pulse may be filtered out, and thus two input pulses will be regarded as one pulse. If the low level pulse width is smaller than  $0.2 \mu\text{s}$ , the pulse will be filtered out.

If you use a  $125 \text{ ns}$  ( $4 \text{ Mpps}$ ) input pulse, set the filter width value Y to 0 to disable the filter function.

Note: when the signal is a high-speed pulse ( $4 \text{ Mpps}$ ) and the value of the filter width is 0, then the pulse is not filtered out.

<b>P1.001</b>	<b>Input for control mode and control command</b>		<b>Address: 0102H 0103H</b>
Default:	0x0000 (A3-M, A3-L) 0x000B (A3-F) 0x000C (A3-E)	Control mode:	All
Unit:	-	Setting range:	0x0000 - 0x112F
Format:	HEX	Data size:	16-bit

Settings:



YX	Control mode setting	Z	Direction control
-	-	U	DIO value control

■ YX: control mode setting

Mode	PT	PR	S	T	Sz	Tz
00	▲					
01		▲				
02			▲			
03				▲		
04					▲	
05						▲
Dual mode						
06	▲		▲			
07	▲			▲		
08		▲	▲			
09		▲		▲		
0A			▲	▲		
0B	Operates with the communication mode dedicated for 15MC series PLC models.					
0C	DMCNET mode CANopen mode EtherCAT mode					
0D	▲	▲				
Multi-mode						
0E	▲	▲	▲			
0F	▲	▲		▲		
Y = 1	Second development platform mode					

PT: Position control mode; the command source is from the external pulse or the external analog voltage (coming soon).

PR: Position control mode; the command source is from the 100 sets of internal registers which you can select with DI.POS0 - DI.POS6. Multiple homing methods are also available.

S: Speed control mode; the command source is from the external analog voltage or the internal register, which you can select with DI.SPD0 and DI.SPD1.

T: Torque control mode; the command source is from the external analog voltage or the internal register, which you can select with DI.TCM0 and DI.TCM1.

8

Sz: Speed control mode; the speed command is zero or the command source is from the internal speed registers, which you can select with DI.SPD0 and DI.SPD1.

Tz: Torque control mode; the torque command is zero or the command source is from the internal torque registers, which you can select with DI.TCM0 and DI.TCM1.

Dual mode: you can switch between two modes with the external DI. For example, you can use DI.S-P to switch the dual mode of PT-S (control mode setting: 06). Refer to Table 8.1 for further information.

Multi-mode: you can switch between three modes with the external DI. For example, you can use DI.S-P and DI.PT-PR to switch the multi-mode of PT-PR-S (control mode setting: 0E). Refer to Table 8.1 for further information.

Communication mode: the command source is from the external fieldbus controller, which sends the command to the servo drive through direct communication.

Note: if the command source is the external analog voltage, make sure to connect the voltage source properly to avoid floating connection causing misoperation.

■ Z: direction control

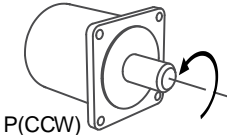
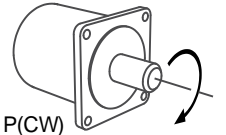
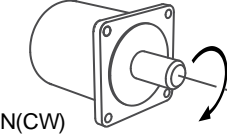
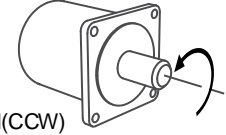
	Z = 0	Z = 1
Positive direction		
Negative direction		

■ U: DIO value control (volatile)

0: when modes are switched, DIO settings remain the same.

1: when modes are switched, DIO settings are reset to the default for each mode.

Note: the default DIO settings of each mode varies based on the servo drive model. For A3-L and A3-M models, refer to Section 3.4.1.1. For A3-F and A3-E models, refer to Section 3.4.2.1.

<b>P1.002 ▲</b>	<b>Speed and torque limits</b>		<b>Address: 0104H 0105H</b>
Default:	0x0000	Control mode:	All
Unit:	-	Setting range:	0x0000 - 0x0011
Format:	HEX	Data size:	16-bit

Settings:



X	Disable / enable Speed Limit function	UZ	Reserved
Y	Disable / enable Torque Limit function	-	-

- X: disable / enable Speed Limit function
  - 0: disable Speed Limit function
  - 1: enable Speed Limit function (only available in T and Tz modes)

See the following diagram for Speed Limit setting:

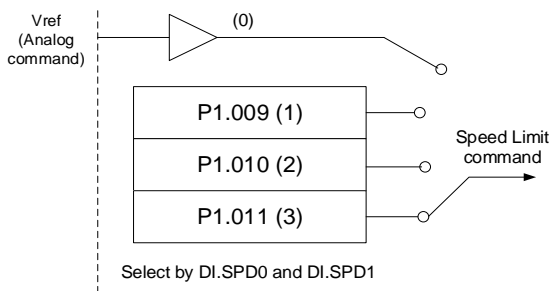

- Y: disable / enable Torque Limit function
  - 0: disable Torque Limit function
  - 1: enable Torque Limit function

See the following diagram for Torque Limit setting:

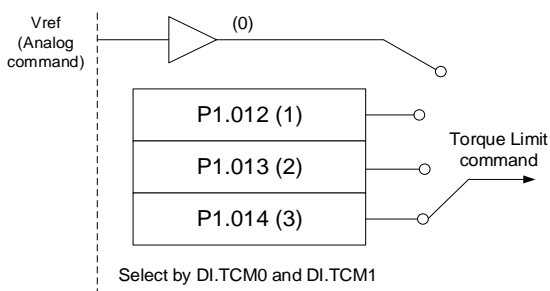

When using the Torque Limit function, set P1.002.Y to 1 to enable the Torque Limit function permanently without occupying a DI setting. Alternatively, you can enable or disable the Torque limit function with DI.TRQLM, which is more flexible, but the setting then occupies a DI setting. You can enable the Torque Limit function by either P1.002 or DI.

<b>P1.003</b>	<b>Encoder pulse output polarity</b>		<b>Address: 0106H 0107H</b>
Default:	0x0000	Control mode:	All
Unit:	-	Setting range:	0x0000 to 0x0013
Format:	HEX	Data size:	16-bit

Settings:



U Z Y X

X	Polarity of monitor analog output	Z	Reserved
Y	Direction of encoder pulse output	U	Reserved

- X: polarity of monitor analog output
  - 0: MON1(+), MON2(+)
  - 1: MON1(+), MON2(-)
  - 2: MON1(-), MON2(+)
  - 3: MON1(-), MON2(-)
- Y: direction of encoder pulse output
  - 0: positive direction
  - 1: negative direction

<b>P1.004</b>	<b>MON1 analog monitor output proportion</b>		<b>Address: 0108H 0109H</b>
Default:	100	Control mode:	All
Unit:	% (full scale)	Setting range:	0 to 100
Format:	DEC	Data size:	16-bit

Settings:

Refer to P0.003 for the analog output setting. Calculations for the rotary motors (rpm) and linear motors (mm/s) are the same.

Example 1:

If the application requires the motor to run at 1,000 rpm (1,000 mm/s) when the input voltage is 8V, its maximum speed is 5,000 rpm (5,000 mm/s), and then the setting of P1.004 is:

$$P1.004 = \frac{\text{Required speed}}{\text{Maximum speed}} \times 100\% = \frac{1000}{5000} \times 100\% = 20\%$$

Refer to the following examples for the motor's current speed and corresponding voltage output:

Motor speed	MON1 analog monitor output
300 rpm (300 mm/s)	$MON1 = 8V \times \frac{\text{Current speed}}{\text{Maximum speed} \times \frac{P1.004}{100}} \times 100\% = 8V \times \frac{300}{5000 \times \frac{20}{100}} \times 100\% = 2.4V$
900 rpm (900 mm/s)	$MON1 = 8V \times \frac{\text{Current speed}}{\text{Maximum speed} \times \frac{P1.004}{100}} \times 100\% = 8V \times \frac{900}{5000 \times \frac{20}{100}} \times 100\% = 7.2V$

<b>P1.005</b>	<b>MON2 analog monitor output proportion</b>		<b>Address: 010AH 010BH</b>	
Default:	100	Control mode:	All	
Unit:	% (full scale)	Setting range:	0 to 100	
Format:	DEC	Data size:	16-bit	

Settings:

Refer to P0.003 for the analog output setting.

<b>P1.006</b>	<b>Speed command - smoothing constant (low-pass filter)</b>		<b>Address: 010CH 010DH</b>	
Default:	0	Control mode:	S / Sz	
Unit:	ms	Setting range:	0 to 1000	
Format:	DEC	Data size:	16-bit	

Settings:

0: disable this function.

<b>P1.007</b>	<b>Torque command - smoothing constant (low-pass filter)</b>		<b>Address: 010EH 010FH</b>	
Default:	0	Control mode:	T / Tz	
Unit:	ms	Setting range:	0 to 1000	
Format:	DEC	Data size:	16-bit	

Settings:

0: disable this function.

<b>P1.008</b>	<b>Position command - smoothing constant (low-pass filter)</b>		<b>Address: 0110H 0111H</b>	
Default:	0	Control mode:	PT / PR	
Unit:	10 ms	Setting range:	0 to 1000	
Format:	DEC	Data size:	16-bit	
Example:	11 = 110 ms			

Settings:

0: disable this function.



8

P1.009	Internal Speed command 1 / internal speed limit 1		Address: 0112H 0113H
Default:	1000	Control mode:	S / Sz: internal Speed command 1 T / Tz: internal speed limit 1
Unit:	0.1 rpm (rotary)* 1 $\mu$ m/s (linear)*	Setting range:	-75000 to +75000 (rotary)* -15999999 to +15999999 (linear)*
Format:	DEC	Data size:	32-bit
Example:	Internal Speed command: 120 = 12 rpm (rotary)*; 120 = 12 $\mu$ m/s (linear)* Internal speed limit: positive and negative values are identical. Refer to the following descriptions.		

Settings:

Internal Speed command 1: first internal Speed command.

Internal speed limit 1: first internal speed limit.

Example of internal speed limit:

Speed limit value of P1.009	Valid speed range	Speed limit in forward direction	Speed limit in reverse direction
1000	-100 to +100 rpm (rotary)*	100 rpm (rotary)*	-100 rpm (rotary)*
-1000	-1000 to +1000 $\mu$ m/s (linear)*	1000 $\mu$ m/s (linear)*	-1000 $\mu$ m/s (linear)*

Note: rotary means a permanent-magnet synchronous rotary motor; linear means a permanent-magnet synchronous linear motor.

P1.010	Internal Speed command 2 / internal speed limit 2		Address: 0114H 0115H
Default:	2000	Control mode:	S / Sz: internal Speed command 2 T / Tz: internal speed limit 2
Unit:	0.1 rpm (rotary)* 1 $\mu$ m/s (linear)*	Setting range:	-75000 to +75000 (rotary)* -15999999 to +15999999 (linear)*
Format:	DEC	Data size:	32-bit
Example:	Internal Speed command: 120 = 12 rpm (rotary)*; 120 = 12 $\mu$ m/s (linear)* Internal speed limit: positive and negative values are identical. Refer to the following descriptions.		

Settings:

Internal Speed command 2: second internal Speed command.

Internal speed limit 2: second internal speed limit.

Example of internal speed limit:

Speed limit value of P1.010	Valid speed range	Speed limit in forward direction	Speed limit in reverse direction
1000	-100 to +100 rpm (rotary)*	100 rpm (rotary)*	-100 rpm (rotary)*
-1000	-1000 to +1000 $\mu$ m/s (linear)*	1000 $\mu$ m/s (linear)*	-1000 $\mu$ m/s (linear)*

Note: rotary means a permanent-magnet synchronous rotary motor; linear means a permanent-magnet synchronous linear motor.

P1.011	Internal Speed command 3 / internal speed limit 3		Address: 0116H 0117H
Default:	3000	Control mode:	S / Sz: internal Speed command 3 T / Tz: internal speed limit 3
Unit:	0.1 rpm (rotary)* 1 µm/s (linear)*	Setting range:	-75000 to +75000 (rotary)* -15999999 to +15999999 (linear)*
Format:	DEC	Data size:	32-bit
Example:	Internal Speed command: 120 = 12 rpm (rotary)*; 120 = 12 µm/s (linear)* Internal speed limit: positive and negative values are identical. Refer to the following descriptions.		

Settings:

Internal Speed command 3: third internal Speed command.

Internal speed limit 3: third internal speed limit.

Example of internal speed limit:

Speed limit value of P1.011	Valid speed range	Speed limit in forward direction	Speed limit in reverse direction
1000	-100 to +100 rpm (rotary)*	100 rpm (rotary)*	-100 rpm (rotary)*
-1000	-1000 to +1000 µm/s (linear)*	1000 µm/s (linear)*	-1000 µm/s (linear)*

Note: rotary means a permanent-magnet synchronous rotary motor; linear means a permanent-magnet synchronous linear motor.

P1.012	Internal Torque command 1 / internal torque limit 1		Address: 0118H 0119H
Default:	100	Control mode:	T / Tz: internal Torque command 1 PT / PR / S / Sz: internal torque limit 1
Unit:	%	Setting range:	-5000 to +5000
Format:	DEC	Data size:	16-bit

Settings:

Internal Torque command 1: first internal Torque command.

Internal torque limit 1: first internal torque limit.

- When P2.112 [Bit 14] = 0 (the torque is in units of 1%):

Internal Torque command: 35 = 35%

Internal torque limit: positive and negative values are identical. Refer to the following descriptions.

Example of internal torque limit:

Torque limit value of P1.012	Valid torque range	Torque limit in forward direction	Torque limit in reverse direction
35	-35% to +35%	35%	-35%
-35			

- When P2.112 [Bit 14] = 1 (the torque is in units of 0.1 %):

Internal Torque command: 35 = 3.5%

Internal torque limit: positive and negative values are identical. Refer to the following descriptions.

8

## 3. Example of internal torque limit:

Torque limit value of P1.012	Valid torque range	Torque limit in forward direction	Torque limit in reverse direction
35	-3.5% to +3.5%	3.5%	-3.5%
-35			

P1.013	Internal Torque command 2 / internal torque limit 2		Address: 011AH 011BH
Default:	100	Control mode:	T / Tz: internal Torque command 2 PT / PR / S / Sz: internal torque limit 2
Unit:	%	Setting range:	-5000 to +5000
Format:	DEC	Data size:	16-bit

Settings:

Internal Torque command 2: second internal Torque command.

Internal torque limit 2: second internal torque limit.

## 1. When P2.112 [Bit 14] = 0 (the torque is in units of 1%):

Internal Torque command: 35 = 35%

Internal torque limit: positive and negative values are identical. Refer to the following descriptions.

Example of internal torque limit:

Torque limit value of P1.013	Valid torque range	Torque limit in forward direction	Torque limit in reverse direction
35	-35% to +35%	35%	-35%
-35			

## 2. When P2.112 [Bit 14] = 1 (the torque is in units of 0.1 %):

Internal Torque command: 35 = 3.5%

Internal torque limit: positive and negative values are identical. Refer to the following descriptions.

Example of internal torque limit:

Torque limit value of P1.013	Valid torque range	Torque limit in forward direction	Torque limit in reverse direction
35	-3.5% to +3.5%	3.5%	-3.5%
-35			

P1.014	Internal Torque command 3 / internal torque limit 3		Address: 011CH 011DH
Default:	100	Control mode:	T / Tz: internal Torque command 3 PT / PR / S / Sz: internal torque limit 3
Unit:	%	Setting range:	-5000 to +5000
Format:	DEC	Data size:	16-bit

Settings:

Internal Torque command 3: third internal Torque command.

Internal torque limit 3: third internal torque limit.

1. When P2.112 [Bit 14] = 0 (the torque is in units of 1%):

Internal Torque command: 35 = 35%

Internal torque limit: positive and negative values are identical. Refer to the following descriptions.

Example of internal torque limit:

Torque limit value of P1.014	Valid torque range	Torque limit in forward direction	Torque limit in reverse direction
35	-35% to +35%	35%	-35%
-35			

2. When P2.112 [Bit 14] = 1 (the torque is in units of 0.1 %):

Internal Torque command: 35 = 3.5%

Internal torque limit: positive and negative values are identical. Refer to the following descriptions.

Example of internal torque limit:

Torque limit value of P1.014	Valid torque range	Torque limit in forward direction	Torque limit in reverse direction
35	-3.5% to +3.5%	3.5%	-3.5%
-35			

P1.015	E-Cam: filter setting for synchronous Capture axis correction		Address: 011EH 011FH
Default:	0x0000	Control mode:	PR
Unit:	-	Setting range:	0x0000 - 0x1F5F
Format:	HEX	Data size:	16-bit

Settings:



YX	Range of filter (0 - 95%)	Z	Filter intensity (0 - F)
U	Filter function status	-	-

8

- YX: range of filter (0 - 95%)

The new correction rate is calculated after the synchronous Capture axis captures the signal. The filter function is enabled when both the new and previous correction rates are less than the range (%) set in this parameter. Otherwise, the error is corrected with the new correction rate.

YX	Description
00	Filter disabled
01 - 5F	If $  \text{Error}   \leq (1 - \text{YX})\%$ , then the filter is enabled

- Z: filter intensity (0 - F)

When  $2^{\text{(set value)}}$  times of error is captured, the average of the error is used for correction. Set to 0, and the filter is disabled. When you set the Z value higher, you can avoid drastic correction and interference caused by the sensor noise, which allows the movement to be more stable. However, setting this value too high causes the correction to not work properly. The recommended value is 3.

Example: when the filter intensity is set to 3, the actual filter intensity =  $2^3 = 8$ , which means that after capturing the error values 8 times, the servo takes the average of the 8 values for the correction value of the synchronous Capture axis.

- U: filter function status (read-only)

U	Filter function	Description
0	Disabled	Correction rate is out of the YX set range
1	Enabled	Correction rate is within the YX set range

P1.016	E-Cam: error offset compensation for synchronous Capture axis		Address: 0120H 0121H
Default:	0	Control mode:	PR
Unit:	Pulse unit of master axis	Setting range:	-32768 to +32767
Format:	DEC	Data size:	16-bit

Settings:

When the synchronous Capture axis is enabled and you want to change the offset of the synchronous axis (P5.079), use this parameter to write the offset value.

When you write P1.016, the value of P5.079 is the error correction for the previous capturing (P5.079) plus the offset value set in P1.016.

When you read P1.016, the read value equals the value of P5.079.

Note: the setting value of this parameter is accumulative, which is not affected by the current error amount.

P1.017	Additional compensation time for the following error		Address: 0122H 0123H
Default:	0	Control mode:	PR
Unit:	ms (minimum scale is $\mu$ s)	Setting range:	-25.000 to +25.000 (includes 3 decimal places)
Format:	DEC	Data size:	16-bit

Settings:

When the following error compensation function is enabled (P1.036 = 1), the servo calculates the compensation amount according to the command and adjusts the position error (PUU) close to 0. If setting the position feed forward gain (P2.002) and position integral compensation (P2.053) cannot reduce the position error, set the additional compensation time to compensate the error.

$$\text{Additional compensation distance} = P1.017 \times \text{Motor speed}$$

Note: enable the following error compensation function (P1.036 = 1) to use the additional compensation function.

P1.018	E-Cam: compensation time for the pulse of E-Cam master axis		Address: 0124H 0125H
Default:	0	Control mode:	PR
Unit:	ms (minimum scale is $\mu$ s)	Setting range:	-25.000 to +25.000 (includes 3 decimal places)
Format:	DEC	Data size:	16-bit

Settings:

During the operation of the E-Cam, if the mechanical factor is excluded, but the following error still exists, which may be error caused by the electrical delay. Set the compensation pulse number of the master axis to correct the E-Cam phase. If the compensation time is set to 0, the compensation is not enabled.

$$\text{Compensation pulse} = P1.018 \times (\text{Pulse frequency of the E-Cam master axis (Kpps)} - P1.021 (\text{Minimum frequency of pulse compensation for the E-Cam master axis}))$$

Note: monitor the pulse frequency of the E-Cam master axis (Kpps) with the monitoring variable 060 (3Ch).

P1.019	Capture / Compare: additional function settings		Address: 0126H 0127H
Default:	0x0000	Control mode:	All
Unit:	-	Setting range:	0x0000 - 0x0101
Format:	HEX	Data size:	16-bit

Settings:



X	Additional function for Capture	Z	Additional function for Compare
Y	Reserved	U	Reserved

8

- X: additional function for Capture

Bit	3	2	1	0
-----	---	---	---	---

Bit	Function	Description
0	Cycle mode	Set this bit to 0 to disable this function. When the number of capturing times (P5.038) is 0, capturing is complete. Set this bit to 1 to enable this function. When the number of capturing times (P5.038) is 0, the servo drive automatically resets the number of capturing times to the default setting.
1 to 3	Reserved	-

- Z: additional function for Compare

Bit	3	2	1	0
-----	---	---	---	---

Bit	Function	Description
0	P1.024 is reset to 0 automatically	Set this bit to 0 to disable this function. The value of P1.024 remains after the comparing is complete. Set this bit to 1 to enable this function. P1.024 automatically resets to 0 after taking effect once.
1 to 3	Reserved	-

P1.020	Capture: masking range	Address: 0128H 0129H
Default:	0	Control mode: All
Unit:	Pulse unit of capture source	Setting range: 0 to +100000000
Format:	DEC	Data size: 32-bit

Settings:

When the Capture function is enabled and set to capture multiple points (P5.038 > 1), use this parameter to set the range within which the system stops receiving the DI captured signal once the data is captured. The DI captured signal received within this range is not recognized as valid. Use this function to prevent the system from seeing noise as effective signals within the non-capture range.

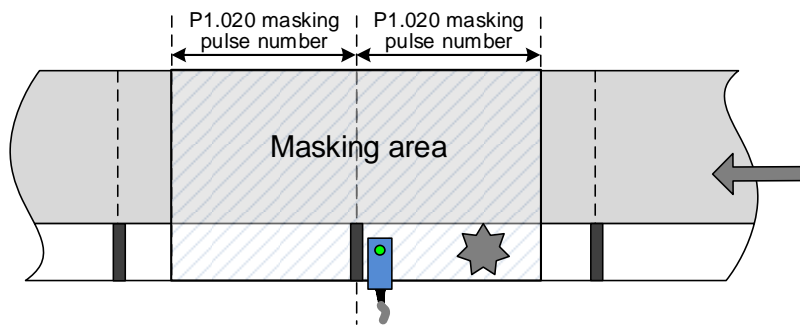

The system activates the masking area after capturing this mark.

P1.021	E-Cam: minimum frequency of pulse compensation for the E-Cam master axis		Address: 012AH 012BH
Default:	0	Control mode:	PR
Unit:	Kpps	Setting range:	0 to +30000
Format:	DEC	Data size:	16-bit

Settings:

During the operation of the E-Cam, if the mechanical factor is excluded, but the following error still exists, which may be error caused by the electrical delay. Set the compensation pulse number of the master axis to correct the E-Cam phase.

Compensation pulse = P1.018 (Compensation time for the pulse of the E-Cam master axis) x (Pulse frequency of the E-Cam master axis (Kpps) - P1.021)

Note: monitor the pulse frequency of the E-Cam master axis (Kpps) with the monitoring variable 060 (3Ch). The pulse frequency of the E-Cam master axis (Kpps) must be greater than P1.021 so the pulse is compensated.

P1.022	PR command special filter		Address: 012CH 012DH
Default:	0x0000	Control mode:	PR
Unit:	-	Setting range:	0x0000 - 0x107F
Format:	HEX	Data size:	16-bit

Settings:



YX	Acceleration / deceleration time limit (0 - 1270 ms)	Z	Reserved
U	Reverse inhibit	-	-

- YX: acceleration / deceleration time limit (0 - 1270 ms)

If the PR command changes too drastically, it causes mechanical vibration. Set the acceleration / deceleration time limit (the time required for the motor to accelerate from 0 to 3,000 rpm or to decelerate from 3,000 rpm to 0<sup>Note</sup>) with this function. If the acceleration / deceleration time of the command is shorter than this limit, the filter takes effect to smooth the acceleration / deceleration which prevents the command from changing too drastically and causing mechanical vibration. When the filter is functioning, the lag caused by the smooth command is automatically compensated after the command is smoothed, so the final position is not deviated.

Example:

Set YX to 12 and the acceleration / deceleration time limit as 180 ms (data format is HEX and unit is 10 ms). If the acceleration / deceleration time of the PR command is shorter than 180 ms, the filter takes effect. If the acceleration / deceleration time of the PR command is longer than 180 ms, the filter does not take effect.



8

Note:

- 1. If you are using a linear motor, this function sets the time required for the linear motor to accelerate from 0 to 5 m/s or to decelerate from 5 m/s to 0.

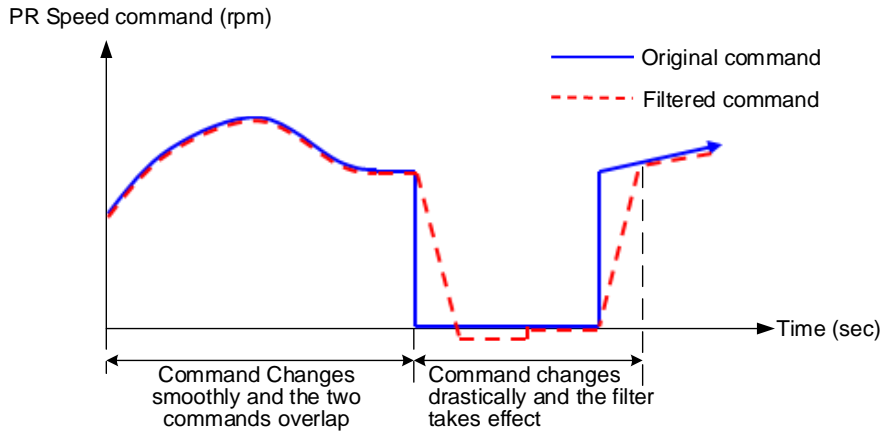

- 2. If the command keeps changing drastically, the following error of the internal position exceeds the allowable range and then triggers AL404.

■ U: reverse inhibit

0: disable this function.

1: enable this function. When the value of the current position command is lower than that of the previous position command, the motor does not move.

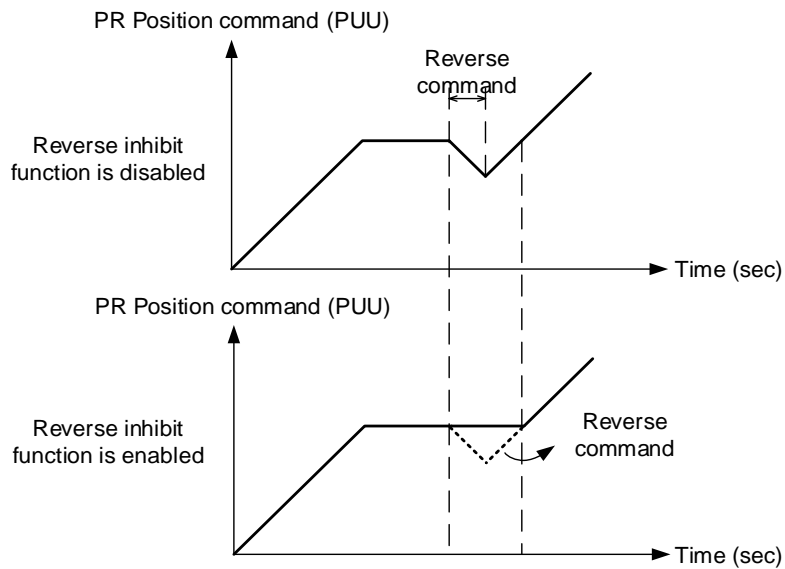

<b>P1.023</b>	<b>Compare: data shift (non-volatile)</b>		<b>Address: 012EH 012FH</b>
Default:	0	Control mode:	All
Unit:	Pulse unit of compare source	Setting range:	-10000000 to +100000000
Format:	DEC	Data size:	32-bit

Settings:

This parameter sets the shifting amount for the data array to be compared. And the result is the actual data array for comparison when you use the Compare function.

$$\text{CMP\_DATA} = \text{DATA\_ARRAY[*]} + \text{P1.023} + \text{P1.024}$$

Example:

If the data array for comparison is  $\text{DATA\_ARRAY}[100] = 2000$ ;  $\text{P1.023} = 40$ ;  $\text{P1.024} = 0$ , the actual data for comparison =  $2000 + 40 = 2040$ .

Note: monitor CMP\_DATA with the monitoring variable 037 (25h).

<b>P1.024</b>	<b>Compare: data shift (reset automatically)</b>		<b>Address: 0130H 0131H</b>
Default:	0	Control mode:	All
Unit:	Pulse unit of compare source	Setting range:	-32768 to +32767
Format:	DEC	Data size:	16-bit

Settings:

This parameter sets the shifting amount for the data array to be compared. And the result is the actual data array for comparison when you use the Compare function.

$$\text{CMP\_DATA} = \text{DATA\_ARRAY[*]} + \text{P1.023} + \text{P1.024}$$

Note:

1. If P1.019.Z [Bit 0] = 1, this parameter automatically resets after taking effect.
2. Monitor CMP\_DATA with the monitoring variable 037 (25h).

<b>P1.025</b>	<b>Low-frequency vibration suppression frequency 1</b>		<b>Address: 0132H 0133H</b>
Default:	1000	Control mode:	PT / PR
Unit:	0.1 Hz	Setting range:	10 to 1000
Format:	DEC	Data size:	16-bit
Example:	150 = 15 Hz		

Settings:

The frequency of the first low-frequency vibration suppression filter. When you set P1.026 to 0, the first low-frequency vibration suppression filter is disabled.

8

<b>P1.026</b>	<b>Low-frequency vibration suppression gain 1</b>		<b>Address: 0134H 0135H</b>
Default:	0	Control mode:	PT / PR
Unit:	-	Setting range:	0 to 9
Format:	DEC	Data size:	16-bit

## Settings:

The gain of the first low-frequency vibration suppression filter. Increase the value to improve the position response. If you set the value too high, the motor may not operate smoothly. The suggested value is 1. Set P1.026 to 0 to disable the first low-frequency vibration suppression filter.

<b>P1.027</b>	<b>Low-frequency vibration suppression frequency 2</b>		<b>Address: 0136H 0137H</b>
Default:	1000	Control mode:	PT / PR
Unit:	0.1 Hz	Setting range:	10 to 1000
Format:	DEC	Data size:	16-bit
Example:	150 = 15 Hz		

## Settings:

The frequency of the second low-frequency vibration suppression filter. When you set P1.028 to 0, the second low-frequency vibration suppression filter is disabled.

<b>P1.028</b>	<b>Low-frequency vibration suppression gain 2</b>		<b>Address: 0138H 0139H</b>
Default:	0	Control mode:	PT / PR
Unit:	-	Setting range:	0 to 9
Format:	DEC	Data size:	16-bit

## Settings:

The gain of the second low-frequency vibration suppression filter. Increase the value to improve the position response. If you set the value too high, the motor may not operate smoothly. The suggested value is 1. Set P1.028 to 0 to disable the second low-frequency vibration suppression filter.

<b>P1.029</b>	<b>Auto low-frequency vibration suppression mode</b>		<b>Address: 013AH 013BH</b>
Default:	0	Control mode:	PT / PR
Unit:	-	Setting range:	0 to 1
Format:	DEC	Data size:	16-bit

## Settings:

Setting value	Setting description
0	Disable the automatic low-frequency vibration detection function.
1	Vibration suppression is in automatic mode. When the vibration cannot be detected or the vibration frequency is stable, the system resets the parameter to 0 and automatically saves the vibration suppression frequency to P1.025.

<b>P1.030</b>	<b>Low-frequency vibration detection</b>		<b>Address: 013CH 013DH</b>
Default:	8000	Control mode:	PT / PR
Unit:	pulse	Setting range:	1 to 128000
Format:	DEC	Data size:	32-bit

Settings:

Sets the detection level when automatic vibration suppression is enabled (P1.029 = 1). The lower the value, the more sensitive the detection, but the system may also misjudge noise or treat other low-frequency vibrations as frequencies to be suppressed. If the value is high, the system is less likely to misjudge, but if the vibration of the machine is small, the system may not properly detect low-frequency vibrations.

<b>P1.031</b>	<b>Reserved</b>
---------------	-----------------

<b>P1.032</b>	<b>Motor stop mode</b>		<b>Address: 0140H 0141H</b>
Default:	0x0000	Control mode:	All
Unit:	-	Setting range:	0x0000 to 0x0020
Format:	HEX	Data size:	16-bit

Settings:



X	Reserved	Z	Reserved
Y	Motor stop mode	U	Reserved

■ Y: motor stop mode

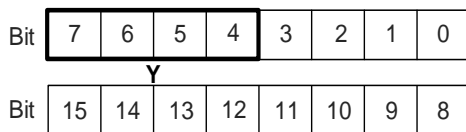

Bit	Function	Description
Bit 5, Bit 4	Dynamic brake operation options	Options for stopping the motor when the servo is in the Servo Off state or an alarm (including EMGS) occurs. Bit 5 = 0 and Bit 4 = 0: use dynamic brake Bit 5 = 0 and Bit 4 = 1: motor runs freely Bit 5 = 1 and Bit 4 = 0: use dynamic brake first, and then let the motor run freely once the speed is slower than the value of P1.038
Bit 6	Trigger stop command when RST power error (AL022) occurs <sup>Note</sup>	0: disable this function. 1: when P1.043 is a negative value and RST power error (AL022) occurs, the servo drive commands the motor to decelerate to 0 in the Servo On state.
Bit 7	Reserved	-

When the motor reaches PL (CCWL) or NL (CWL), refer to P5.003 for setting the deceleration time. If you set the deceleration time to 1 ms, the motor stops instantly.

Note: this function is only available in Position and Speed (PT, PR, S, and Sz) modes and is effective only when P1.043 (Delay time for disabling the magnetic brake) is a negative value.

<b>P1.033</b>	<b>Reserved</b>
---------------	-----------------

<b>P1.034</b>	<b>S-curve acceleration constant</b>		<b>Address: 0144H 0145H</b>
Default:	200	Control mode:	S / Sz
Unit:	ms	Setting range:	1 to 65500
Format:	DEC	Data size:	16-bit

Settings:

Sets the time for the rotary motor to accelerate from zero to 3000 rpm or the time for the linear motor to accelerate from zero to 5 m/s. You can set P1.034, P1.035, and P1.036 individually. When an internal command is used, even if you set P1.036 to 0, the acceleration and deceleration follow a trapezoid-curve; when an analog command is used, you must set P1.036 larger than 0 so that the acceleration and deceleration follow a trapezoid-curve.

<b>P1.035</b>	<b>S-curve deceleration constant</b>		<b>Address: 0146H 0147H</b>
Default:	200	Control mode:	S / Sz
Unit:	ms	Setting range:	1 to 65500
Format:	DEC	Data size:	16-bit

Settings:

Sets the time for the rotary motor to decelerate from 3000 rpm to zero or the time for the linear motor to decelerate from 5 m/s to zero. You can set P1.034, P1.035, and P1.036 individually. When an internal command is used, even if you set P1.036 to 0, the acceleration and deceleration follow a trapezoid-curve; when an analog command is used, you must set P1.036 larger than 0 so that the acceleration and deceleration follow a trapezoid-curve.

<b>P1.036</b>	<b>S-curve acceleration / deceleration constant</b>		<b>Address: 0148H 0149H</b>
Default:	0	Control mode:	PR / S / Sz
Unit:	ms	Setting range:	0 to 65500
Format:	DEC	Data size:	16-bit

Settings:

0: disable this function.

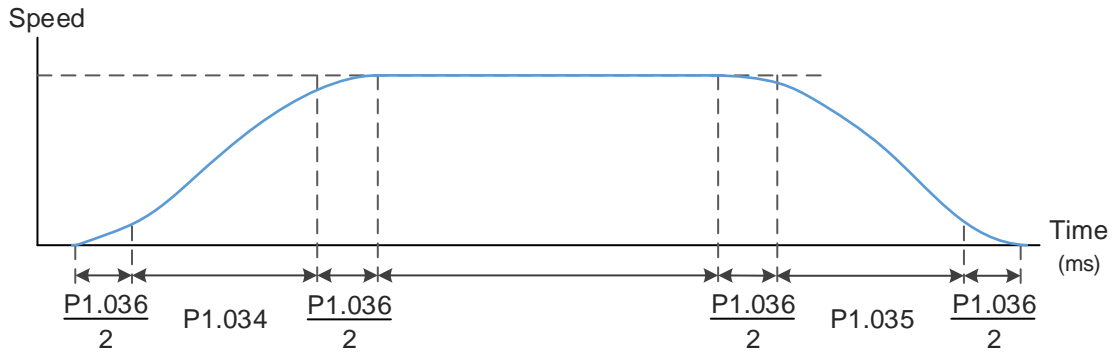

P1.034: sets the acceleration time for the trapezoid-curve.

P1.035: sets the deceleration time for the trapezoid-curve.

P1.036: sets the smoothing time for the S-curve acceleration and deceleration.

You can set P1.034, P1.035, and P1.036 individually. Even if you set P1.036 to 0, the acceleration and deceleration still follow a trapezoid-curve.

	P1.036 = 0	P1.036 = 1	P1.036 > 1
Smoothing function for S-curve	Disabled	Disabled	Enabled
Following error compensation function	Disabled	Enabled	Determined by P2.068.X

P1.037	Load inertia ratio or total weight			Address: 014AH 014BH
Operation interface:	Panel / software	Communication	Control mode:	PT / PR / S / Sz
Default:	6.0	60	Data size:	32-bit
Unit:	1 times (rotary)* 1 kg (linear)*	0.1 times (rotary)* 0.1 kg (linear)*	-	-
Setting range:	0.0 to 200.0 (rotary)* 0.0 to 6553.5 (linear)*	0 to 2000 (rotary)* 0 to 65535 (linear)*	-	-
Format:	One decimal	DEC	-	-
Example:	1.5 = 1.5 times / kg	15 = 1.5 times / kg	-	-

Settings:

Rotary motor load inertia ratio (J\_load / J\_motor) or total weight of linear motor mover and load (M\_motor + M\_load).

J\_motor: rotor inertia of the servo motor

J\_load: total equivalent inertia of external mechanical load

M\_motor: weight of the linear motor mover

M\_load: total equivalent weight of external mechanical load

Note: rotary means a permanent-magnet synchronous rotary motor; linear means a permanent-magnet synchronous linear motor.

8

P1.038	Zero speed range			Address: 014CH 014DH
Operation interface:	Panel / software	Communication	Control mode:	All
Default:	10.0	100	Data size:	16-bit
Unit:	1 rpm (rotary)* 1 mm/s (linear)*	0.1 rpm (rotary)* 0.1 mm/s (linear)*	-	-
Setting range:	0.0 to 200.0	0 to 2000	-	-
Format:	One decimal	DEC	-	-
Example:	1.5 = 1.5 rpm 1.5 = 1.5 mm/s	15 = 1.5 rpm 15 = 1.5 mm/s	-	-

## Settings:

Sets the range for the zero-speed signal (ZSPD). When the absolute value of the motor speed is lower than this value, the zero-speed signal is triggered and DO.ZSPD is on.

Note: rotary means a permanent-magnet synchronous rotary motor; linear means a permanent-magnet synchronous linear motor.

P1.039	Target speed detection level		Address: 014EH 014FH
Default:	3000	Control mode:	All
Unit:	1 rpm (rotary)* 1 mm/s (linear)*	Setting range:	0 to 30000 (rotary)* 0 to 15999 (linear)*
Format:	DEC	Data size:	16-bit

## Settings:

Sets the motor target speed. When the absolute value of the motor speed is higher than this value, the condition for triggering the target speed reached signal is met and DO.TSPD is on.

Note: rotary means a permanent-magnet synchronous rotary motor; linear means a permanent-magnet synchronous linear motor.

P1.040	Maximum motor speed for analog Speed command 1		Address: 0150H 0151H
Default:	Rated speed	Control mode:	S / T
Unit:	1 rpm (rotary)* 1 mm/s (linear)*	Setting range:	0 to 50000 (rotary)* 0 to 15999 (linear)*
Format:	DEC	Data size:	32-bit

## Settings:

In Speed mode:

Sets the motor speed corresponding to 10V (maximum voltage) for the analog Speed command.

$$\text{Speed control command} = \frac{\text{Input voltage} \times \text{P1.040}}{10}$$

If the value is 2000 and the external voltage input is 5V, then the speed control command =  $\frac{5V \times 2000}{10V} = 1000$  rpm (1000 mm/s).

In Torque mode:

Sets the motor speed limit corresponding to 10V (maximum voltage) for the analog speed limit.

$$\text{Speed limit command} = \frac{\text{Input voltage} \times P1.040}{10}$$

If the value is 2000 and the external voltage input is 5V, then the speed limit command =  $\frac{5V \times 2000}{10V} = 1000$  rpm (1000 mm/s).

Note: rotary means a permanent-magnet synchronous rotary motor; linear means a permanent-magnet synchronous linear motor.

<b>P1.041 ▲</b>	<b>Maximum output for analog Torque command</b>		<b>Address: 0152H 0153H</b>
Default:	100	Control mode:	All
Unit:	%	Setting range:	-1000 to +1000
Format:	DEC	Data size:	16-bit

Settings:

In Torque mode:

Sets the torque corresponding to 10V (maximum voltage) for the analog Torque command.

$$\text{Torque control command} = \frac{\text{Input voltage} \times P1.041}{10} \text{ (Unit: \%)}$$

In Speed, PT, and PR modes:

Sets the torque limit corresponding to 10V (maximum voltage) for the analog torque limit.

$$\text{Torque limit command} = \frac{\text{Input voltage} \times P1.041}{10} \text{ (Unit: \%)}$$

Example:

When P1.041 = 10 and the external analog voltage input is 10V, the torque control (limit) command =  $\frac{10V \times 10}{10} = 10\%$

<b>P1.042</b>	<b>Delay time for enabling the magnetic brake</b>		<b>Address: 0154H 0155H</b>
Default:	0	Control mode:	All
Unit:	ms	Setting range:	0 to 1000
Format:	DEC	Data size:	16-bit

Settings:

Sets the delay time from Servo On status to the activation of the magnetic brake signal (DO: 0x08, BRKR).

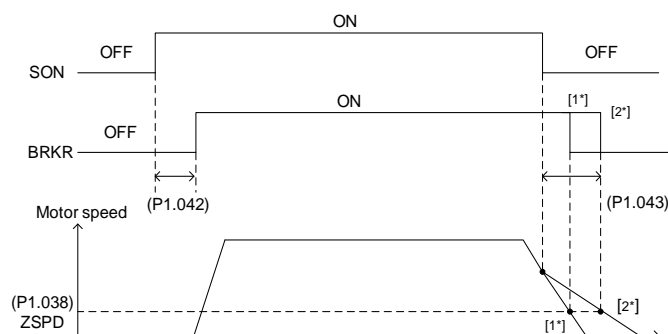



## 8

Note:

1. If the delay time specified in P1.042 has not passed yet and the motor speed is slower than the value of P1.038, the magnetic brake signal (BRKR) is disabled.
2. If the delay time specified in P1.042 has passed and the motor speed is faster than the value of P1.038, the magnetic brake signal (BRKR) is disabled.

<b>P1.043</b>	<b>Delay time for disabling the magnetic brake</b>		<b>Address: 0156H 0157H</b>
Default:	0	Control mode:	All
Unit:	ms	Setting range:	-1000 to +1000
Format:	DEC	Data size:	16-bit

Settings:

Sets the delay time from Servo Off status to the deactivation of the magnetic brake signal (DO: 0x08, BRKR). Refer to P1.042 for the detailed diagram.

Note: if P1.043 is a negative value and the servo is off due to an alarm (except for AL022) or emergency stop, the setting of P1.043 is invalid. This is equivalent to setting the delay time to 0.

<b>P1.044 ▲</b>	<b>E-Gear ratio - numerator N1</b>		<b>Address: 0158H 0159H</b>
Default:	16777216	Control mode:	PT / PR
Unit:	pulse	Setting range:	1 to ( $2^{29}-1$ )
Format:	DEC	Data size:	32-bit

Settings:

For the E-Gear ratio setting, refer to Section 6.2.5. For multiple E-Gear ratio (numerator) settings, refer to P2.060 - P2.062.

Note:

1. Do not change the setting in the Servo On state.
2. In communication mode (DMCNET / CANopen / EtherCAT), if you cycle the power to the drive, the E-Gear ratio is set to the default value of the communication protocol. Resetting to the default value results in the re-establishment of the absolute position system, so you must re-do the homing procedure. If you do not want P1.045 to be reset to the default value, set P3.012.Z to 1. For details, refer to P3.012.

P1.045 ▲	E-Gear ratio - denominator M		Address: 015AH 015BH	
Default:	100000	Control mode:	PT / PR	
Unit:	pulse	Setting range:	1 to $(2^{31}-1)$	
Format:	DEC	Data size:	32-bit	

Settings:

If the setting is incorrect, the servo motor is prone to sudden unintended acceleration. Follow these instructions.

E-Gear ratio setting:  $f_2 = f_1 \times \frac{N}{M}$

Pulse of User Unit  
 (PUU)  
 (f1)

$\rightarrow$   $\frac{N}{M}$   $\rightarrow$  Resolution determined by  
 servo drive (pulse)  
 (f2)

Range of E-gear ratio:  $1 < N \times M < 262144$ .

For the E-Gear ratio setting, refer to Section 6.2.5.

Note:

1. Do not change the setting in the Servo On state.
2. In communication mode (DMCNET / CANopen / EtherCAT), if you cycle the power to the drive, the E-Gear ratio is set to the default value of the communication protocol. Resetting to the default value results in the re-establishment of the absolute position system, so you must re-do the homing procedure. If you do not want P1.045 to be reset to the default value, set P3.012.Z to 1. For details, refer to P3.012.

P1.046 ▲	Encoder pulse number output (OA, OB)		Address: 015CH 015DH	
Default:	2500	Control mode:	All	
Unit:	pulse	Setting range:	1 to 536870912	
Format:	DEC	Data size:	32-bit	

Settings:

Rotary motor: the number of single-phase pulse outputs per revolution; the maximum output frequency of the hardware is 19.8 MHz.

Linear motor: the number of single-phase pulse outputs per meter; the maximum output frequency of the hardware is 19.8 MHz.

For the OA and OB settings of CN2 and CN5, refer to P1.074.Y (Selection of OA/OB output source) and P1.097 (Encoder output denominator (OA, OB)).

Note:

In the following circumstances, pulse output of the encoder may exceed the maximum allowable output pulse frequency of the drive, causing AL018 or AL048:

1. Encoder error.
2. The motor speed is faster than P1.076.
3. Rotary motor: if  $P1.074.Y = 0$  and  $P1.097 = 0$ , motor speed (rpm)/60  $\times$  P1.046  $\times$  4  $>$   $19.8 \times 10^6$   
 Linear motor: if  $P1.074.Y = 1$  and  $P1.097 = 1$ , motor speed (m/s)  $\times$  P1.046  $>$   $19.8 \times 10^6$



<b>P1.047</b>	<b>Speed reached (DO.SP_OK) range</b>		<b>Address: 015EH 015FH</b>
Default:	10	Control mode:	S / Sz
Unit:	1 rpm (rotary)* 1 mm/s (linear)*	Setting range:	0 to 300
Format:	DEC	Data size:	16-bit

Settings:

In Speed mode, when the absolute value of the difference between the Speed command and the motor feedback speed is less than this parameter and this status is kept for the time duration set in P1.049, the digital output DO.SP\_OK (DO: 0x19) is on.

Note: when the difference between the Speed command and the motor feedback speed exceeds the range set in P1.047, the system recalculates the duration.

Diagram:

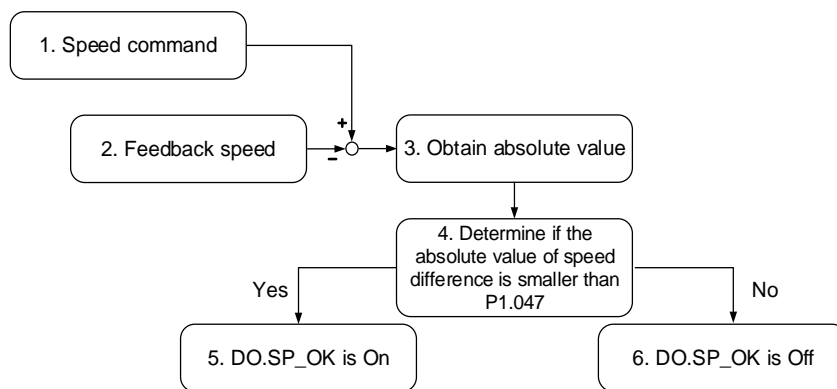

1. Speed command: the command that you input without acceleration or deceleration, rather than the command from the front end speed circuit. Its source is from the register.
2. Feedback speed: the actual speed of the motor which has been filtered.
3. Obtain the absolute value.
4. Determine whether the absolute value of the speed difference is smaller than the parameter value. If you set the parameter to 0, DO.SP\_OK is always off. If the absolute value is smaller than the parameter, the digital output is on, otherwise it is off.

Note: rotary means a permanent-magnet synchronous rotary motor; linear means a permanent-magnet synchronous linear motor.

<b>P1.048</b>	<b>Motion reached (DO.MC_OK) operation selection</b>		<b>Address: 0160H 0161H</b>
Default:	0x0000	Control mode:	PR
Unit:	-	Setting range:	0x0000 - 0x0011
Format:	HEX	Data size:	16-bit

Settings:

Control selection of digital output DO.MC\_OK (DO: 0x17).



X	DO output retaining option	Z	Reserved
Y	Position deviation alarm (AL380) option	U	Reserved

- X: DO output retaining option
  - 0: output status is not retained
  - 1: output status is retained
- Y: position deviation alarm (AL380) option
  - 0: AL380 not functioning
  - 1: AL380 functioning

Diagram:

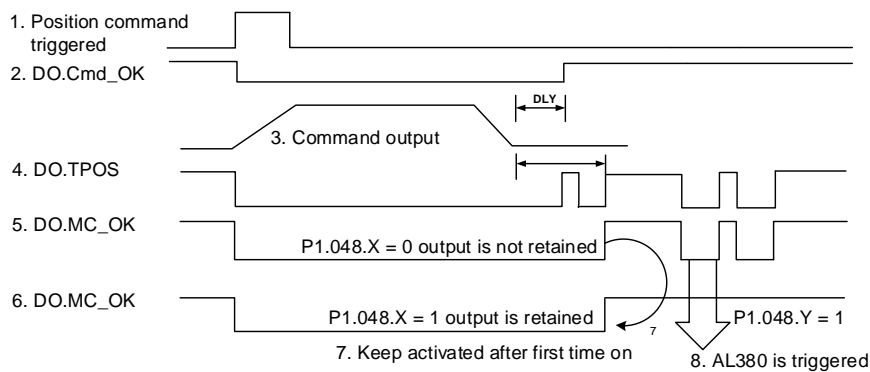

Description:

1. Command triggered: new PR command is effective. Command 3 starts and clears signals 2, 4, 5, and 6 simultaneously. Command triggering source: DI.CTRG, DI.EV1/EV2, and P5.007 (triggered through software).
2. DO.Cmd\_OK: command 3 is complete and it can set the delay time (DLY).
3. Command output: output the profile of the Position command based on the acceleration / deceleration setting.
4. DO.TPOS: position error of the servo drive is within the range set in P1.054.
5. DO.MC\_OK: Position command output and servo positioning completed, which indicate that DO.Cmd\_OK and DO.TPOS are both on.
6. DO.MC\_OK (retains digital output status): same as 5, except that once this DO is on, its status is retained regardless of the signal 4 status.

7. Either signal 5 or signal 6 can be output, and this is determined by P1.048.X.
8. Position deviation: when event 7 occurs, if signal 4 (or 5) is off, it means the position has deviated and AL380 can be triggered. Set whether to enable AL380 with P1.048.Y.

## 8

P1.049	Accumulated time to reach desired speed		Address: 0162H 0163H
Default:	0	Control mode:	S / Sz
Unit:	ms	Setting range:	0 to 65535
Format:	DEC	Data size:	16-bit

Settings:

In Speed mode, when the absolute value of the difference between the Speed command and the motor feedback speed is less than the range set in P1.047 and this status is kept for the time duration set in P1.049, the digital output DO.SP\_OK (DO: 0x19) is on. If the difference exceeds the range set in P1.047, no matter how long it lasts, the system recalculates the duration.

P1.050 - P1.051	Reserved
-----------------	----------

P1.052	Regenerative resistor value		Address: 0168H 0169H
Default:	Determined by the model. Refer to the following table.	Control mode:	All
Unit:	Ohm	Setting range:	Refer to the following table.
Format:	DEC	Data size:	16-bit

Settings:

	Model	Default ( $\Omega$ )	Setting range ( $\Omega$ )
220V	750 W or below	100	60 - 750
	1 kW - 1.5 kW	100	30 - 750
	2 kW - 3 kW	20	15 - 750
	4.5 kW	20	10 - 750
	5.5 kW - 7.5 kW	20	8 - 750
	11 kW	20	6 - 750
	15 kW	20	5 - 750
400V	400 W	80	80 - 750
	750 kW - 1 kW	80	60 - 750
	1.5 kW - 2 kW	80	40 - 750
	3 kW	80	30 - 750
	4.5 kW - 5.5 kW	80	25 - 750
	7.5 kW - 15 kW	80	15 - 750

Refer to the description of P1.053 for the parameter values when connecting the regenerative resistor through different methods.

<b>P1.053</b>	<b>Regenerative resistor capacity</b>		<b>Address: 016AH 016BH</b>
Default:	Determined by the model. Refer to the following table.	Control mode:	All
Unit:	Watt	Setting range:	0 to 15000
Format:	DEC	Data size:	16-bit

Settings:

	Model	Default (Watt)
220V	200 W or below	0
	400 W - 1.5 kW	40
	2 kW - 3 kW	80
	4.5 kW	60
	5.5 kW - 7.5 kW	0
	11 kW - 15 kW	0
400V	1.5 kW or below	60
	2 kW - 15 kW	0

Setting the parameter value when connecting the regenerative resistor with different methods:

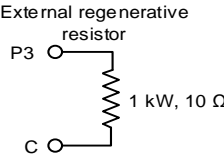
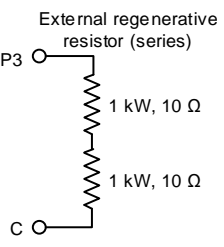
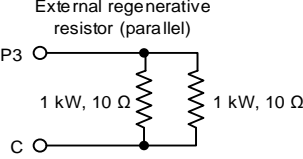
External regenerative resistor	Setting
<p>External regenerative resistor</p> 	<p>Setting: P1.052 = 10 (Ω) P1.053 = 1000 (W)</p>
<p>External regenerative resistor (series)</p> 	<p>Setting: P1.052 = 20 (Ω) P1.053 = 2000 (W)</p>
<p>External regenerative resistor (parallel)</p> 	<p>Setting: P1.052 = 5 (Ω) P1.053 = 2000 (W)</p>

8

P1.054	Pulse range for position reached		Address: 016CH 016DH
Default:	167772	Control mode:	PT / PR
Unit:	pulse	Setting range:	0 to 16777216
Format:	DEC	Data size:	32-bit

Settings:

In Position (PT) mode, when the pulse number error is smaller than the range set by P1.054, DO.TPOS is on.

In Position Register (PR) mode, when the difference between the target position and the actual motor position is smaller than the range set by P1.054, DO.TPOS is on.

Example:

For a rotary motor, if P1.054 = 167772 and the error is less than 167772 pulses, which equals 0.01 turns ( $167772 / 16777216 = 0.01$ ), then DO.TPOS is on.

P1.055	Maximum speed limit		Address: 016EH 016FH
Default:	Rated speed of each model (rotary)* Automatically fills in after motor parameter identification (linear)*	Control mode:	All
Unit:	1 rpm (rotary)* 1 mm/s (linear)*	Setting range:	0 to maximum speed
Format:	DEC	Data size:	16-bit

Settings:

Sets the maximum speed of the servo motor.

Note: rotary means a permanent-magnet synchronous rotary motor; linear means a permanent-magnet synchronous linear motor.

P1.056	Motor output overload warning level		Address: 0170H 0171H
Default:	120	Control mode:	All
Unit:	%	Setting range:	0 to 120
Format:	DEC	Data size:	16-bit

Settings:

When the value is 0 - 100 and the servo motor continuously outputs load that is higher than the setting of P1.056, the pre-warning signal for overload (DO: 0x10, OLW) is on. If the value is over 100, the pre-warning function is disabled.

P1.057	Motor hard stop 1 - torque percentage			Address: 0172H 0173H
Default:	0	Control mode:	All	
Unit:	%	Setting range:	0 to 300	
Format:	DEC	Data size:	16-bit	

Settings:

Sets the protection level which is the percentage of rated torque. Set the value to 0 to disable the function and set the value to 1 or above to enable the function.

When there is no external force, the setting value = (motor current in percentage when the motor runs at constant speed in the forward direction + motor current in percentage when the motor runs at constant speed in the reverse direction) / 2 + protection torque value. When there is external force, set P1.060 additionally.

P1.058	Motor hard stop - protection time			Address: 0174H 0175H
Default:	1	Control mode:	All	
Unit:	ms	Setting range:	1 to 1000	
Format:	DEC	Data size:	16-bit	

Settings:

Sets the protection time. When the motor reaches the protection level and the protection time is exceeded, AL030 occurs.

P1.059	Speed command - moving filter			Address: 0176H 0177H
Operation interface:	Panel / software	Communication	Control mode:	S
Default:	0.0	0	Data size:	16-bit
Unit:	1 ms	0.1 ms	-	-
Format:	One decimal	DEC	-	-
Setting range:	0.0 to 4.0	0 to 40	-	-
Example:	1.5 = 1.5 ms	15 = 1.5 ms	-	-

Settings:

0: disable moving filter.

P1.006 is the low-pass filter and P1.059 is the moving filter. The difference between them is the moving filter can smooth the beginning and end of the step command, while the low-pass filter can only smooth the command at the end.

Therefore, if the speed loop receives the command from the controller for the position control loop, then the low-pass filter is recommended. If the setting is only for the speed control, then use the moving filter for better smoothing.



8

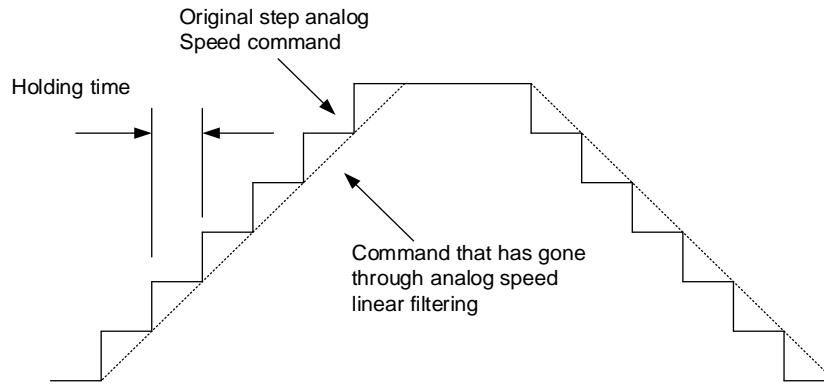

P1.060	Motor hard stop 1 - level offset		Address: 0178H 0179H	
Default:	0	Control mode:	All	
Unit:	%	Setting range:	-300 to +300	
Format:	DEC	Data size:	16-bit	

Settings:

When using P1.057 (Motor hard stop 1 - torque percentage) and the average torque level deviates due to an external force, such as Z-axis gravity, you can use this parameter to set the corresponding compensation.

Suggested setting value = (Average torque at constant speed in positive direction + Average torque at constant speed in negative direction) / 2

Note: refer to P0.002 = 54 (Torque feedback) for the average torque at constant speed.

P1.061	Viscous friction compensation		Address: 017AH 017BH	
Default:	0	Control mode:	PT / PR / S / Sz	
Unit:	0.1%/1000 rpm (rotary)* 0.1%/1000 mm/s (linear)*	Setting range:	0 to 1000	
Format:	DEC	Data size:	16-bit	

Settings:

Because viscous friction corresponds with the speed, you can use this parameter to compensate the motor torque according to the speed to improve the position error during acceleration and deceleration.

When P1.062 = 0, this parameter is invalid.

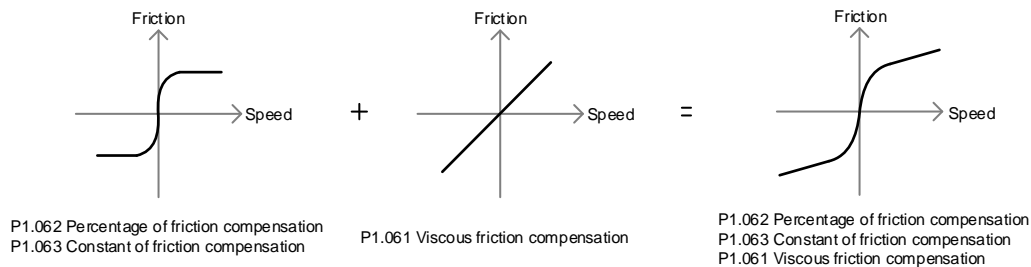

Note: rotary means a permanent-magnet synchronous rotary motor; linear means a permanent-magnet synchronous linear motor.

<b>P1.062</b>	<b>Percentage of friction compensation</b>		<b>Address: 017CH 017DH</b>
Default:	0	Control mode:	PT / PR / S / Sz
Unit:	%	Setting range:	0 to 100
Format:	DEC	Data size:	16-bit

Settings:

Sets the level of friction compensation, which is the percentage of the rated torque. Set the value to 0 to disable the friction compensation function. Set the value to 1 or above to enable the function to reduce the position error at the moment the motion starts.

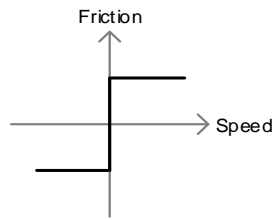

Percentage of friction compensation P1.062

<b>P1.063</b>	<b>Constant of friction compensation</b>		<b>Address: 017EH 017FH</b>
Default:	100	Control mode:	PT / PR / S / Sz
Unit:	%	Setting range:	1 to 1000
Format:	DEC	Data size:	16-bit

Settings:

Use this parameter to set the speed for the friction compensation value to reach the setting value of P1.062. Based on the default setting of 100%, the smaller the setting value of P1.063, the faster the setting value of P1.062 is reached; the bigger the setting value of P1.063, the slower the setting value of P1.062 is reached.

<b>P1.064</b>	<b>Analog position command - activation control</b>		<b>Address: 0180H 0181H</b>
Default:	0x0000	Control mode:	PT
Unit:	-	Setting range:	0x0000 - 0x0011
Format:	HEX	Data size:	16-bit

Settings:



X	Setting for position command issued by the analog signal	Y	Initial position setting	UZ	Reserved
---	--	---	--------------------------	----	----------

8

- X: setting for position command issued by the analog signal
  - 0: disable
  - 1: enable
- Y: initial position setting
  - 0: after the servo is on, the motor regards the current position as the position when the voltage is 0V. Then the motor operates to the corresponding position according to the analog input command.

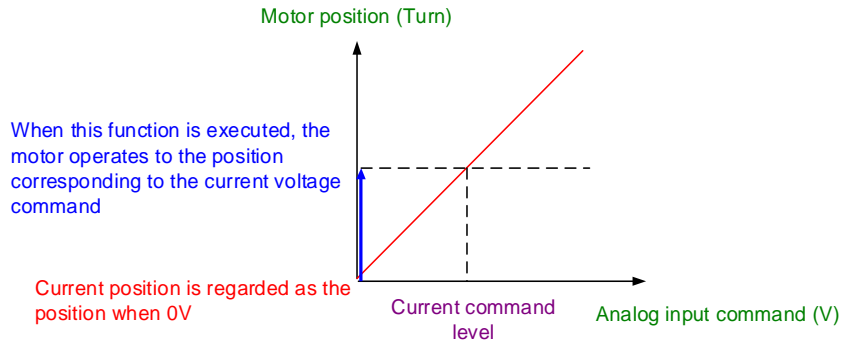

1: after the servo is on, if the command level is not changed, the motor does not operate. The position the motor stops at is the position corresponding to the current command level.

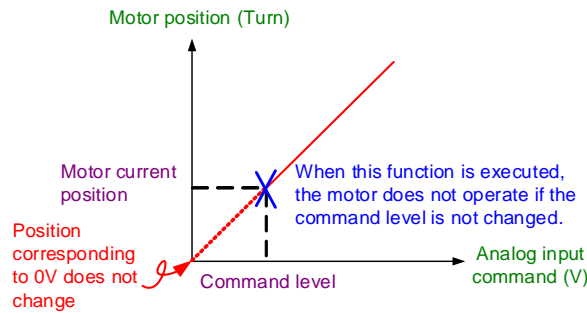

<b>P1.065</b>	<b>Analog Position command - smoothing constant</b>		<b>Address: 0182H 0183H</b>
Default:	1	Control mode:	PT
Unit:	10 ms	Setting range:	1 to 1000
Format:	DEC	Data size:	16-bit

Settings:

The smooth constant of analog Position command is only effective to analog Position command.

<b>P1.066</b>	<b>Analog Position command - maximum cycle number</b>			<b>Address: 0184H 0185H</b>
Operation interface:	Panel / software	Communication	Control mode:	PT
Default:	0.0	0	Data size:	16-bit
Unit:	1 cycle	0.1 cycle	-	-
Format:	One decimal	DEC	-	-
Setting range:	0.0 to 200.0	0 to 2000	-	-
Example:	1.5 = 1.5 cycles	15 = 1.5 cycles	-	-

Settings:

Rotation number setting when the maximum voltage (10V) is input to the analog Position command. If the setting on the panel is 3.0 and the external voltage input is +10V, then the Position command is +3 cycles. If the input is +5V, then the Position command is +1.5 cycles. If the input is -10V, then the Position command is -3 cycles.

$$\text{Position control command} = \text{Input voltage} \times \text{Set value} / 10$$

<b>P1.067</b>	<b>Reserved</b>
---------------	-----------------

<b>P1.068</b>	<b>Position command - moving filter</b>		<b>Address: 0188H 0189H</b>
Default:	4	Control mode:	PT / PR
Unit:	ms	Setting range:	0 to 100
Format:	DEC	Data size:	16-bit

Settings:

0: disable this function.

The moving filter smooths the beginning and end of the step command, but it also delays the command.

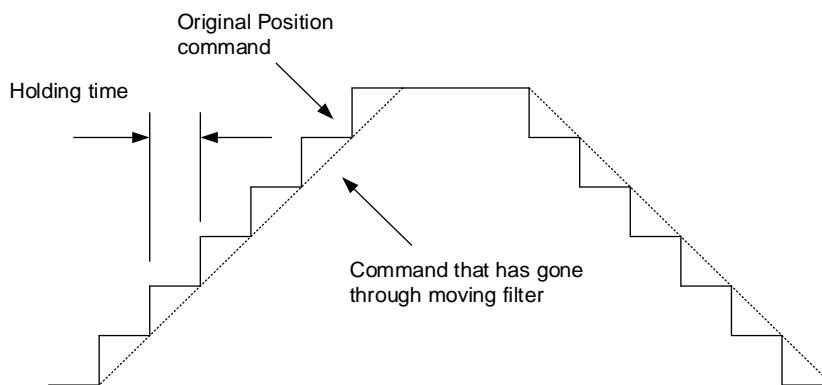

<b>P1.069 - P1.071</b>	<b>Reserved</b>
----------------------------	-----------------

P1.072	Resolution of auxiliary encoder for full-closed loop control		Address: 0190H 0191H	
Default:	5000	Control mode:	PT/PR* (full-closed loop)	
Unit:	pulse/rev	Setting range:	200 to 1280000	
Format:	DEC	Data size:	32-bit	

Settings:

The number of A/B pulses corresponding to a full-closed loop when the motor runs a cycle (after quadruple frequency).

Note: PR full-closed loop function is not yet supported.

P1.073	Protection range for feedback position error between main encoder and auxiliary encoder		Address: 0192H 0193H	
Default:	30000	Control mode:	PT/PR* (full-closed loop)	
Unit:	pulse (based on the feedback of full-closed loop)	Setting range:	1 to (2 <sup>31</sup> -1)	
Format:	DEC	Data size:	32-bit	

Settings:

In full-closed loop control, when the feedback position difference between the auxiliary encoder and the main encoder is too great, it means the connectors are loose or there is a problem with the mechanical part. When the difference is greater than the value of P1.073, AL040 (Excessive position error of full-closed loop control) occurs.

$$P1.073 < \left( \text{Main encoder position [PUU]} \times \frac{P1.044 \times P1.072}{P1.045 \times 16777216} \right) - \text{Auxiliary encoder position [Pulse]}$$

In the preceding expression:

Main encoder position [PUU] = Feedback position [PUU] (when P1.074.X = 0) - Feedback position [PUU] (when P1.074.X = 1)

Auxiliary encoder position [Pulse] = Auxiliary encoder feedback [Pulse] (when P1.074.X = 0) - Auxiliary encoder feedback [Pulse] (when P1.074.X = 1)

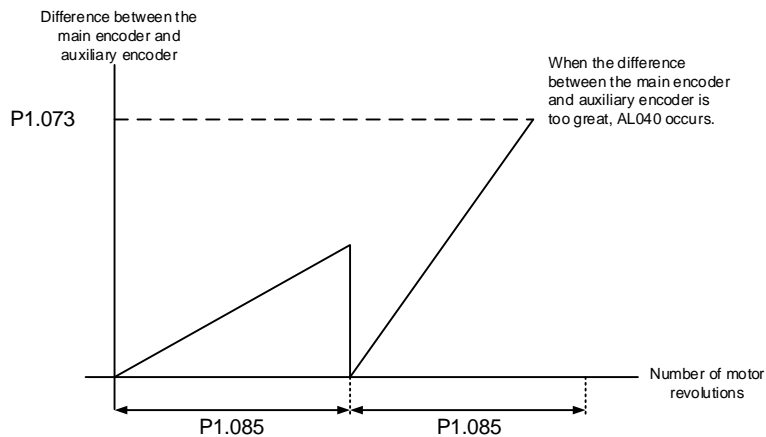

Note: PR full-closed loop function is not yet supported.

<b>P1.074</b>	<b>Full-closed loop control switch</b>		<b>Address: 0194H 0195H</b>
Default:	0x0000	Control mode:	PT/PR* (full-closed loop)
Unit:	-	Setting range:	0000h to F132h
Format:	HEX	Data size:	16-bit

Settings:



X	Full-closed loop / Gantry function switch	Z	Feedback direction (positive / negative) of auxiliary encoder
Y	Selection of OA / OB / OZ output source	U	Filter width setting for CN5 feedback pulse

- X: full-closed loop / Gantry function switch
  - 0: disable full-closed loop / Gantry function
  - 1: enable full-closed loop function
  - 2: enable gantry synchronization function
- Y: selection of OA / OB / OZ output source
  - 0: CN2 encoder is the output source
  - 1: CN5 encoder is the output source
    - (If P1.097 = 0, the OA / OB output must be 1:1. If you need to change the output ratio, refer to the settings of P1.046 and P1.097.)
  - 2: CN1 pulse command is the output source
    - (If P1.097 = 0, the OA / OB output must be 1:1. If you need to change the output ratio, refer to the settings of P1.046 and P1.097.)
- Z: feedback direction (positive / negative) of auxiliary encoder
  - 0: pulse output in positive direction
  - 1: pulse output in negative direction

Note: PR full-closed loop function is not yet supported.
- U: filter width setting for CN5 feedback pulse\*
 

If the pulse frequency is suddenly too high, causing a pulse width smaller than the set filter width, then this pulse gets filtered out as noise. Therefore, set the filter width smaller than the actual pulse width.

You should set the filter width as 4 times smaller than the actual pulse width.

U value	Filter width (pulse frequency) Unit: $\mu$ s (kHz)	U value	Filter width (pulse frequency) Unit: $\mu$ s (kHz)
0	Bypass	8	0.9 (555)
1	0.2 (2500)	9	1.0 (500)
2	0.3 (1666)	A	1.1 (454)
3	0.4 (1250)	B	1.2 (416)
4	0.5 (1000)	C	1.4 (357)
5	0.6 (833)	D	1.6 (312)
6	0.7 (714)	E	2.0 (250)
7	0.8 (625)	F	3.0 (166)

Note: refer to the setting of P1.000.U.

P1.075	Low-pass filter time constant for full- / semi-closed loop control		Address: 0196H 0197H
Default:	100	Control mode:	PT/PR* (full-closed loop)
Unit:	ms	Setting range:	0 to 1000
Format:	DEC	Data size:	16-bit

Settings:

When the stiffness of the mechanical system between full- and semi-closed loops is insufficient, set the proper time constant to enhance the stability of the system. In other words, create a semi-closed loop effect in the transient state. After the system reaches a steady state, the full-closed loop effect is created. When the stiffness is sufficient, set to bypass. Set the value to 0 to disable the low-pass filter function (bypass).

If the stiffness of the mechanical system is high, decrease the value of P1.075 or set the value to 0 to disable the low-pass filter function. If the stiffness of the mechanical system is low, increase the value of P1.075.

Note: PR full-closed loop function is not yet supported.

P1.076 ▲	Maximum speed for encoder output (OA, OB)		Address: 0198H 0199H
Default:	5500	Control mode:	All
Unit:	1 rpm (rotary)* 1 mm/s (linear)*	Setting range:	0 to 7500 (rotary)* 0 to 15999 (linear)*
Format:	DEC	Data size:	16-bit

Settings:

Please set a value which is slightly higher than the required maximum speed of motor.

Note: rotary means a permanent-magnet synchronous rotary motor; linear means a permanent-magnet synchronous linear motor.

P1.077	Reserved
--------	----------

<b>P1.078</b>	<b>Gain switching delay time</b>		<b>Address: 019CH 019DH</b>	
Default:	0	Control mode:	PT / PR / S / Sz	
Unit:	ms	Setting range:	0 to 32767	
Format:	DEC	Data size:	16-bit	

Settings:

When using the gain switching function (P2.027.X = 3 or 7), you can use this parameter to set the delay time after the switching condition is met. Refer to the description of P2.027 for more details.

<b>P1.079</b>	<b>Rate of change for gain values during gain switching delay</b>		<b>Address: 019EH 019FH</b>	
Default:	100	Control mode:	PT / PR / S / Sz	
Unit:	%	Setting range:	0 to 500	
Format:	DEC	Data size:	16-bit	

Settings:

Sets the rate of change for the gain values during gain switching delay. If P1.078 is 0, this function is disabled.

Within the delay time set by P1.078, the settings of P2.000 (Position control gain) and P2.004 (Speed control gain) will be affected by the setting of P1.079. Refer to the description of P2.027 for more details.

<b>P1.080</b>	<b>Rate of change for speed detection filter and jitter suppression</b>		<b>Address: 01A0H 01A1H</b>	
Default:	100	Control mode:	PT / PR / S / Sz	
Unit:	%	Setting range:	0 to 100	
Format:	DEC	Data size:	16-bit	

Settings:

Adjusts the rate of change for speed detection filter and jitter suppression (P2.049) according to the gain switching condition. (This parameter is inversely proportional to the value of P2.049. The smaller the setting value, the stronger the filtering effect.)

<b>P1.081</b>	<b>Maximum motor speed for analog Speed command 2</b>		<b>Address: 01A2H 01A3H</b>	
Default:	Rated speed	Control mode:	S / T	
Unit:	1 rpm (rotary)* 1 mm/s (linear)*	Setting range:	0 to 50000 (rotary)* 0 to 15999 (linear)*	
Format:	DEC	Data size:	32-bit	

Settings:

Refer to the description of P1.040.

Note: rotary means a permanent-magnet synchronous rotary motor; linear means a permanent-magnet synchronous linear motor.



8

P1.082	Time constant for switching between P1.040 and P1.081		Address: 01A4H 01A5H
Default:	0	Control mode:	S / T
Unit:	ms	Setting range:	0 to 1000 (0: disable this function)
Format:	DEC	Data size:	16-bit

Settings:

0: disable this function.

P1.083	Abnormal analog input voltage level		Address: 01A6H 01A7H
Default:	0	Control mode:	S
Unit:	mV	Setting range:	0 to 12000 (0: disable this function)
Format:	DEC	Data size:	16-bit

Settings:

When the analog input voltage is higher than the set value of this parameter for more than 50 ms, AL042 occurs. The comparison value for this parameter is the original analog input voltage which has not been changed by an offset value through P4.022 (Analog speed input - offset compensation value).

P1.084	Error clearing function when switching between full- and semi-closed loops		Address: 01A8H 01A9H
Default:	0x0000	Control mode:	PT / PR*1 (full-closed loop)
Unit:	-	Setting range:	0x0000 - 0x0001
Format:	HEX	Data size:	16-bit

Settings:

U Z Y X

X	Error clearing function when the system switches from semi-closed loop to full-closed loop	Z	Reserved
Y	Reserved	U	Reserved

- X: error clearing function when the system switches from semi-closed loop to full-closed loop\*2

0: clear the error when switching.

When the system is in semi-closed loop control, the command refers to the motor encoder, and the position does not move after the system switches to full-closed loop.

1: no clearing of the error when switching.

When the system is in semi-closed loop control, the command refers to the motor encoder.

After the system switches to full-closed loop, the command issued in semi-closed loop

becomes the full-closed loop command, and thus the position moves.

Note:

1. PR full-closed loop function is not yet supported.
2. Use DI [0x0B] to switch between full- and semi-closed loop modes.

Example:

- Error clearing enabled (P1.084.X = 0)

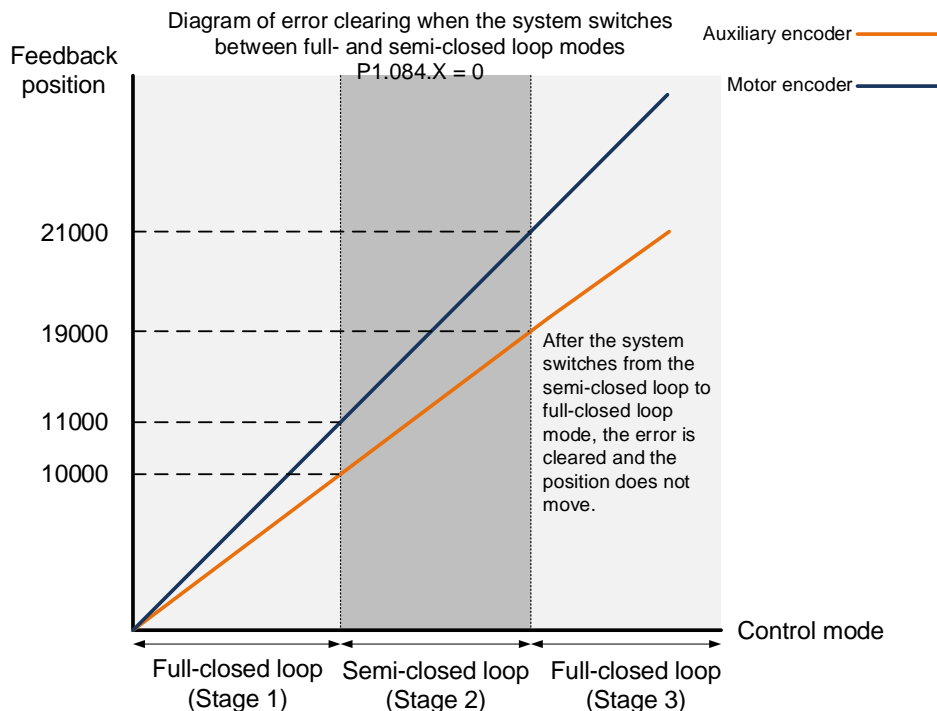

#### Stage 1: full-closed loop control (feedback position of the auxiliary encoder)

If the servo drive issued a position command of 10,000 PUU and the feedback position of the auxiliary encoder is 10,000 PUU, the final feedback position of the motor encoder is 11,000 PUU due to the backlash and sliding of the mechanical parts.

#### Stage 2: semi-closed loop control (feedback position of the motor encoder)

Use DI [0x0B] to switch the control mode from full-closed loop to semi-closed loop, and then issue the position command of 10,000 PUU again. In semi-closed loop control, since the command refers to the position of the motor encoder, the feedback position of the motor encoder is 21,000 PUU, but the feedback position of the auxiliary encoder is 19,000 PUU. In this mode, there is an error of 1,000 PUU between the auxiliary encoder (19,000 PUU) and the position command (20,000 PUU).

#### Stage 3: full-closed loop control (feedback position of the auxiliary encoder)

When you set P1.084 to 0, the error will be cleared. Thus, after using DI [0x0B] to switch the control mode from semi-closed loop to full-closed loop, the feedback position of the auxiliary encoder is not corrected.

- Error clearing disabled (P1.084.X = 1)

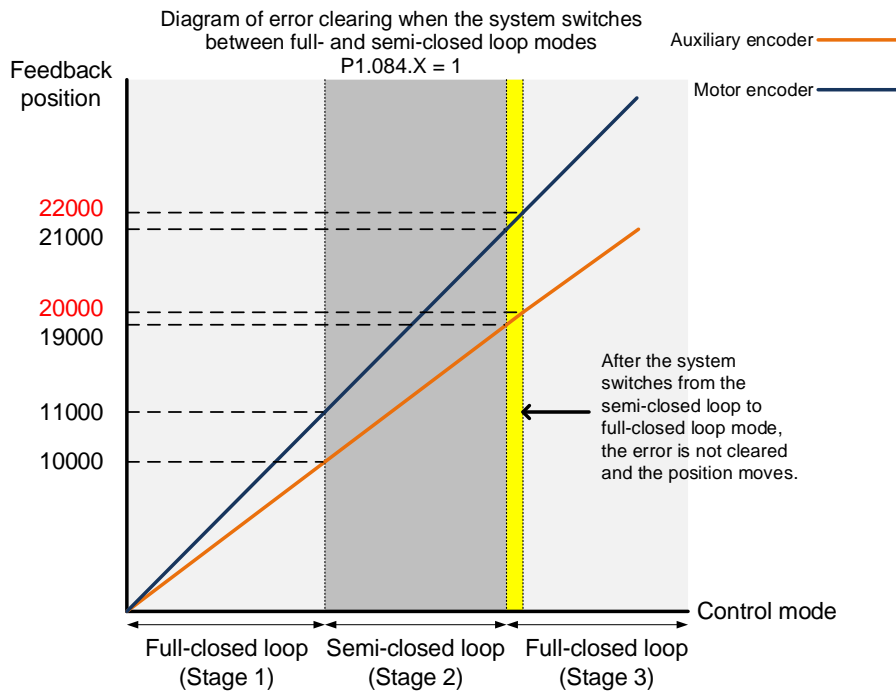

#### Stage 1: full-closed loop control (feedback position of the auxiliary encoder)

If the servo drive issued a position command of 10,000 PUU and the feedback position of the auxiliary encoder is 10,000 PUU, the final feedback position of the motor encoder is 11,000 PUU due to the backlash and sliding of the mechanical parts.

#### Stage 2: semi-closed loop control (feedback position of the motor encoder)

Use DI [0x0B] to switch the control mode from full-closed loop to semi-closed loop, and then issue the position command of 10,000 PUU again. In semi-closed loop control, since the command refers to the position of the motor encoder, the feedback position of the motor encoder is 21,000 PUU, but the feedback position of the auxiliary encoder is 19,000 PUU. In this mode, there is an error of 1,000 PUU between the auxiliary encoder (19,000 PUU) and the position command (20,000 PUU).

#### Stage 3: full-closed loop control (feedback position of the auxiliary encoder)

When you set P1.084 to 1, the error will not be cleared. Thus, after using DI [0x0B] to switch the control mode from semi-closed loop to full-closed loop, the feedback position of the auxiliary encoder is corrected and the motor moves to the corresponding position (yellow area as shown in the preceding figure). The previous semi-closed loop command becomes the full-closed loop command and refers to the auxiliary encoder to move the mechanical part to the position corresponding to the actual command. The final feedback position of the auxiliary encoder is 20,000 PUU.

<b>P1.085</b>	<b>Auto clearing of the feedback position error between the main encoder and auxiliary encoder</b>		<b>Address: 01AAH 01ABH</b>
Default:	0	Control mode:	PT / PR* (full-closed loop)
Unit:	rev	Setting range:	0 to 32768 (0: disable this function)
Format:	DEC	Data size:	16-bit

Settings:

This parameter sets the upper limit of the feedback position error between the main encoder and auxiliary encoder. When the number of motor revolutions is greater than or equal to this parameter value, the system automatically clears the error.

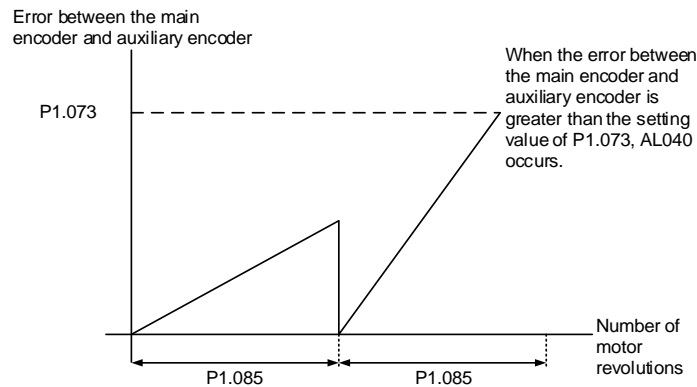

Note: PR full-closed loop function is not yet supported.

<b>P1.086</b>	<b>Reserved</b>
---------------	-----------------

<b>P1.087</b>	<b>Torque homing - torque level detection</b>		<b>Address: 01AEH 01AFH</b>
Default:	1	Control mode:	PR
Unit:	%	Setting range:	1 to 300
Format:	DEC	Data size:	16-bit

Settings:

This setting is only for the torque homing mode. As shown in the following figure, after homing is triggered, the motor runs in one direction and the mechanical part reaches the protector. The servo drive then outputs a larger motor current in order to counter the external force. The servo drive uses P1.087 and P1.088 as the conditions for homing. Since the hard stops are not always the same, it is recommended that you have the servo reverse to find the Z pulse as the origin.

8

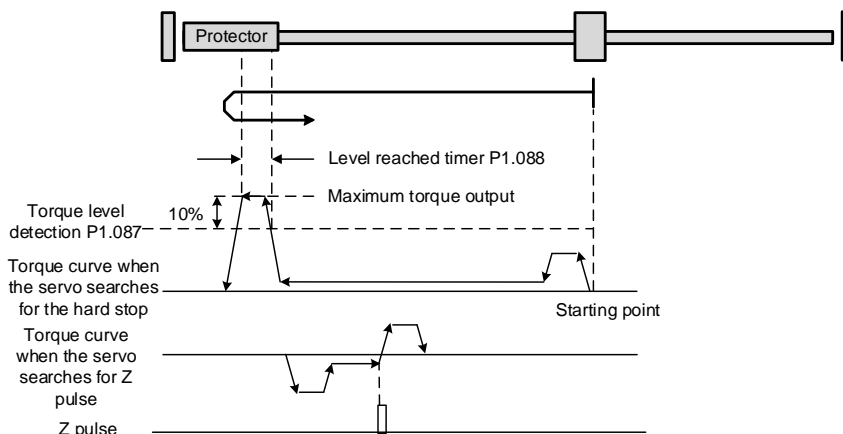

Note: the actual maximum torque output of the motor is 10% greater than the detected torque level (P1.087). For example: set P1.087 to 50%, and then the maximum torque output of the motor is 60%.

P1.088	Torque homing - level reached timer		Address: 01B0H 01B1H
Default:	2000	Control mode:	PR
Unit:	ms	Setting range:	2 to 2000
Format:	DEC	Data size:	16-bit

Settings:

The setting of the **torque level reached timer** for the torque homing mode. If the motor torque output continues to exceed the level set by P1.087 and the duration exceeds this setting, the homing is complete. Refer to P1.087 for the timing diagram of torque homing mode.

P1.089	Vibration elimination 1 - anti-resonance frequency		Address: 01B2H 01B3H
Default:	4000	Control mode:	PT / PR
Unit:	0.1 Hz	Setting range:	10 to 4000
Format:	DEC	Data size:	16-bit

Settings:

Anti-resonance frequency for the first set of low frequency vibration elimination.

Use this function in flexible machines with low rigidity. The definition of a flexible machine is one for which when the target position is reached, due to lack of rigidity, the machine vibrates and needs more time to become stable. The servo drive provides two sets of vibration elimination. The first set is P1.089 - P1.091 and the second set is P1.092 - P1.094. The vibration elimination setting must be obtained through the **System Module** function in **System Analysis** of the ASDA-Soft with the check box for **Low Frequency Analysis** selected.

Vibration elimination takes effect only when the two degree of freedom control function is enabled (P2.094 [Bit 12] = 1). After enabling the two degree of freedom control function, turn on the first set of vibration elimination with P2.094 [Bit 8] and the second set with P2.094 [Bit 9].

Example:

1. Set P2.094 = 0x11□□ to enable the first set.
2. Set P2.094 = 0x12□□ to enable the second set.
3. Set P2.094 = 0x13□□ to enable the first and second sets simultaneously.

P1.090	Vibration elimination 1 - resonance frequency		Address: 01B4H 01B5H
Default:	4000	Control mode:	PT / PR
Unit:	0.1 Hz	Setting range:	10 to 4000
Format:	DEC	Data size:	16-bit

Settings:

Resonance frequency for the first set of low frequency vibration elimination.

P1.091	Vibration elimination 1 - resonance difference		Address: 01B6H 01B7H
Default:	10	Control mode:	PT / PR
Unit:	0.1 dB	Setting range:	10 to 4000
Format:	DEC	Data size:	16-bit

Settings:

Attenuation rate for the first set of low frequency vibration elimination.

P1.092	Vibration elimination 2 - anti-resonance frequency		Address: 01B8H 01B9H
Default:	4000	Control mode:	PT / PR
Unit:	0.1 Hz	Setting range:	10 to 4000
Format:	DEC	Data size:	16-bit

Settings:

Anti-resonance frequency for the second set of low frequency vibration elimination. The setting method is the same as the first set of vibration elimination (P1.089).

P1.093	Vibration elimination 2 - resonance frequency		Address: 01BAH 01BBH
Default:	4000	Control mode:	PT / PR
Unit:	0.1 Hz	Setting range:	10 to 4000
Format:	DEC	Data size:	16-bit

Settings:

Resonance frequency for the second set of low frequency vibration elimination.

8

P1.094	Vibration elimination 2 - resonance difference		Address: 01BCH 01BDH
Default:	10	Control mode:	PT / PR
Unit:	0.1 dB	Setting range:	10 to 4000
Format:	DEC	Data size:	16-bit

Settings:

Attenuation rate for the second set of low frequency vibration elimination.

P1.095 - P1.096	Reserved
--------------------	----------

P1.097 ▲	Encoder output denominator (OA, OB)		Address: 01C2H 01C3H
Default:	0	Control mode:	All
Unit:	-	Setting range:	0 to 160000
Format:	DEC	Data size:	32-bit

Settings:

1. When P1.074.Y = 0 (output source is from the encoder connected to CN2):
  - When P1.097 = 0, OA / OB pulse output refers to the setting of P1.046. (Refer to Example 1.)
  - When P1.097 ≠ 0, OA / OB pulse output refers to the settings of P1.046 and P1.097. (Refer to Example 2.)
2. When P1.074.Y = 1 (output source is from the encoder connected to CN5):
  - When P1.097 = 0, OA / OB pulse output does not refer to the setting of P1.046, but outputs according to the ratio of 1 : 1 instead.
  - When P1.097 ≠ 0:
    - (a) Main encoder is connected to CN5 (PM.003.U = 1): OA / OB pulse output refers to the settings of P1.046 and P1.097. (Refer to Example 2.)
    - (b) Main encoder is connected to CN2 (PM.003.U = 0): OA / OB pulse output refers to the settings of P1.046 and P1.097. (Refer to Example 3.)
3. When P1.074.Y = 2 (output source is the pulse command from CN1):
  - When P1.097 = 0, OA / OB pulse output does not refer to the setting of P1.046, but outputs according to the ratio of 1 : 1 instead.
  - When P1.097 ≠ 0, OA / OB pulse output refers to the settings of P1.046 and P1.097. (Refer to Example 4.)

Example 1 (the value must be multiplied by 4 times the frequency):

When P1.097 = 0 and P1.046 = 2500,

Rotary motor:  $P1.046 \times 4 = 10,000$  pulses, indicating OA / OB outputs 10,000 pulses when the rotary motor rotates 1 cycle.

Linear motor:  $P1.046 \times 4 = 10,000$  pulses, indicating OA / OB outputs 10,000 pulses when the linear motor runs 1 meter.

Example 2 (the calculated value does not need to be multiplied by 4 times the frequency):

When P1.097 = 7 and P1.046 = 2500:

Rotary motor:  $2500/7$  pulses, indicating OA / OB outputs 2,500 pulses when the rotary motor rotates 7 cycles.

Linear motor:  $2500/7$  pulses, indicating OA / OB outputs 2,500 pulses when the linear motor runs 7 meters.

Example 3 (the calculated value does not need to be multiplied by 4 times the frequency):

When P1.097 = 3 and P1.046 = 1, the auxiliary encoder outputs 3 pulses and OA / OB outputs 1 pulse.

Example 4 (the calculated value does not need to be multiplied by 4 times the frequency):

When P1.097 = 3 and P1.046 = 1, the pulse command outputs 3 pulses and OA / OB outputs 1 pulse.

P1.098	Disconnection detection protection (UVW) response time		Address: 01C4H 01C5H
Default:	0	Control mode:	All
Unit:	ms	Setting range:	0, 100 to 800
Format:	DEC	Data size:	16-bit

Settings:

When the switch for motor power cable disconnection detection (ALC31) is enabled (P2.065 [Bit 9] = 1), select the detection response time with this parameter.

Set P1.098 to 0 to use the servo's default response time.

When P1.098 is not set to 0, the setting value should be between 100 and 800 for the detection response time.

Note:

1. If it is necessary to shorten the response time, it is recommended that you use this parameter.
2. When the servo is on and has not started running, it is recommended that you set this parameter if you need to detect disconnection.

P1.099 - P1.100	Reserved
--------------------	----------



8

<b>P1.101</b>	<b>Analog monitor output voltage 1</b>		<b>Address: 01CAH 01CBH</b>
Default:	0	Control mode:	All
Unit:	mV	Setting range:	-10000 to +10000
Format:	DEC	Data size:	16-bit

Settings:

When you set 6 for the monitor source of P0.003 [YX], then the analog monitor output voltage refers to the voltage value of P1.101.

Note: the valid setting range is -8V to +8V.

<b>P1.102</b>	<b>Analog monitor output voltage 2</b>		<b>Address: 01CCH 01CDH</b>
Default:	0	Control mode:	All
Unit:	mV	Setting range:	-10000 to +10000
Format:	DEC	Data size:	16-bit

Settings:

When you set 7 for the monitor source of P0.003 [YX], then the analog monitor output voltage refers to the voltage value of P1.102.

Note: the valid setting range is -8V to +8V.

<b>P1.103 - P1.104</b>	<b>Reserved</b>		
----------------------------	-----------------	--	--

<b>P1.105</b>	<b>Motor hard stop 2 - torque upper limit</b>		<b>Address: 01D2H 01D3H</b>
Default:	0	Control mode:	All
Unit:	%	Setting range:	-300 to +300
Format:	DEC	Data size:	16-bit

Settings:

When Motor hard stop 2 is enabled (P2.112 [Bit 8] = 1), the settings of torque percentage (P1.057) and level offset (P1.060) for Motor hard stop 1 are invalid. During motor operation, if the motor torque is higher than this protection setting value and the duration of this condition exceeds the protection time (P1.058), AL030 will be triggered.

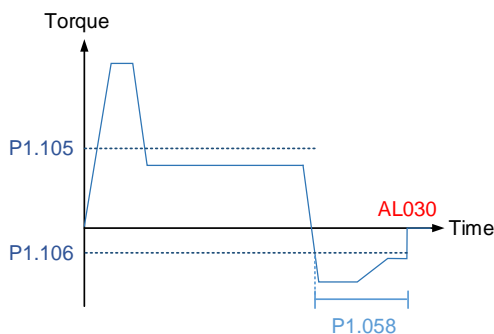

<b>P1.106</b>	<b>Motor hard stop 2 - torque lower limit</b>		<b>Address: 01D4H 01D5H</b>	
Default:	0	Control mode:	All	
Unit:	%	Setting range:	-300 to +300	
Format:	DEC	Data size:	16-bit	

Settings:

When Motor hard stop 2 is enabled (P2.112 [Bit 8] = 1), the settings of torque percentage (P1.057) and level offset (P1.060) for Motor hard stop 1 are invalid. During motor operation, if the motor torque is lower than this protection setting value and the duration of this condition exceeds the protection time (P1.058), AL030 will be triggered.

<b>P1.107 - P1.110</b>	<b>Reserved</b>			
----------------------------	-----------------	--	--	--

<b>P1.111</b>	<b>Overspeed protection level</b>		<b>Address: 01DEH 01DFH</b>	
Default:	Maximum motor speed x 1.1	Control mode:	All	
Unit:	1 rpm (rotary)* 1 mm/s (linear)*	Setting range:	0 to 66000	
Format:	DEC	Data size:	32-bit	

Settings:

This function is to protect the motor from overspeeding, which can be applied to all control modes. When the filtered motor speed exceeds this set speed, AL056 occurs.

Note: rotary means a permanent-magnet synchronous rotary motor; linear means a permanent-magnet synchronous linear motor.

<b>P1.112■</b>	<b>Single-direction torque limit</b>		<b>Address: 01E0H 01E1H</b>	
Default:	500	Control mode:	All	
Unit:	%	Setting range:	-500 to +500	
Format:	DEC	Data size:	16-bit	

Settings:

Refer to the description of P4.044 for more details.

<b>P1.113 - P1.119</b>	<b>Reserved</b>			
----------------------------	-----------------	--	--	--

8

P1.120	STO deactivation settings		Address: 01F0H 01F1H
Default:	3	Control mode:	All
Unit:	-	Setting range:	0 to 3
Format:	DEC	Data size:	16-bit

Settings:

Set P1.120 to deactivate the STO function according to the usage requirements. Refer to Section 3.10.5.3 for details of the timing diagram.

Setting value	Function
0	Switching on the servo drive is invalid / prohibited when the STO function is activated. To deactivate the STO function and restart the servo drive, send the Servo Off command to cancel the state (Servo On invalid / prohibited), and then send the Servo On command. DMCNET communication does not support this setting.
1	AL500 is triggered after the STO function is activated. To deactivate the STO function and restart the servo drive, you have to clear the alarm first and then perform the steps mentioned above when P1.120 is set to 0. DMCNET communication does not support this setting.
2	Switching on the servo drive is invalid / prohibited when the STO function is activated. The servo drive starts to operate again after the STO function is deactivated. DMCNET communication does not support this setting.
3 (Default)	AL500 is triggered after the STO function is activated. To deactivate the STO function and restart the servo drive, you have to clear the alarm.

**P2.xxx Extension parameters**

<b>P2.000</b>	<b>Position control gain</b>		<b>Address: 0200H 0201H</b>	
Default:	35	Control mode:	PT / PR	
Unit:	rad/s	Setting range:	0 to 2047	
Format:	DEC	Data size:	16-bit	

## Settings:

Increasing the position control gain can enhance the position response and reduce the position errors.

If you set the value too high, it may cause vibration and noise.

<b>P2.001</b>	<b>Rate of change for position control gain</b>		<b>Address: 0202H 0203H</b>	
Default:	100	Control mode:	PT / PR	
Unit:	%	Setting range:	10 to 500	
Format:	DEC	Data size:	16-bit	

## Settings:

Adjust the rate of change for the position control gain (P2.000) according to the gain switching condition.

<b>P2.002</b>	<b>Position feed forward gain</b>		<b>Address: 0204H 0205H</b>	
Default:	50	Control mode:	PT / PR	
Unit:	%	Setting range:	0 to 100	
Format:	DEC	Data size:	16-bit	

## Settings:

If the position control command changes smoothly, increasing the gain value can reduce the position following errors. If the position control command does not change smoothly, decreasing the gain value can reduce mechanical vibration.

<b>P2.003</b>	<b>Position feed forward gain smoothing constant</b>		<b>Address: 0206H 0207H</b>	
Default:	5	Control mode:	PT / PR	
Unit:	ms	Setting range:	2 to 100	
Format:	DEC	Data size:	16-bit	

## Settings:

If the position control command changes smoothly, decreasing the smoothing constant value can reduce the position following errors. If the position control command does not change smoothly, increasing the smoothing constant value can reduce mechanical vibration.

8

<b>P2.004</b>	<b>Speed control gain</b>		<b>Address: 0208H 0209H</b>	
Default:	500	Control mode:	PT / PR / S / Sz	
Unit:	rad/s	Setting range:	0 to 8191	
Format:	DEC	Data size:	16-bit	

Settings:

Increasing the speed control gain can enhance the speed response. If you set the value too high, it may cause vibration and noise.

<b>P2.005</b>	<b>Rate of change for speed control gain</b>		<b>Address: 020AH 020BH</b>	
Default:	100	Control mode:	PT / PR / S / Sz	
Unit:	%	Setting range:	10 to 500	
Format:	DEC	Data size:	16-bit	

Settings:

Adjust the rate of change for the speed control gain (P2.004) according to the gain switching condition.

<b>P2.006</b>	<b>Speed integral compensation</b>		<b>Address: 020CH 020DH</b>	
Default:	100	Control mode:	PT / PR / S / Sz	
Unit:	rad/s	Setting range:	0 to 1023	
Format:	DEC	Data size:	16-bit	

Settings:

Increasing the value of the integral speed control can enhance the speed response and reduce the deviation in speed control. If you set the value too high, it may cause vibration and noise.

<b>P2.007</b>	<b>Speed feed forward gain</b>		<b>Address: 020EH 020FH</b>	
Default:	0	Control mode:	PT / PR / S / Sz	
Unit:	%	Setting range:	0 to 100	
Format:	DEC	Data size:	16-bit	

Settings:

If the speed control command changes smoothly, increasing the gain value can reduce the speed following errors. If the speed control command does not change smoothly, decreasing the gain value can reduce mechanical vibration.

<b>P2.008</b>	<b>Special parameter write-in function</b>		<b>Address: 0210H 0211H</b>
Default:	0	Control mode:	All
Unit:	-	Setting range:	0 to 501
Format:	DEC	Data size:	16-bit

Settings:

Special parameter write-in function:

Setting value	Function
10	Reset parameter groups P0 - P7 (cycle the power after reset).
18	Reset parameter group PM (cycle the power after reset).
20	P4.010 is writable.
22	P4.011 - P4.021 are writable.
30, 35	Save Compare, Capture, and E-Cam data.
406	Enable forced DO mode.
400	When forced DO mode is enabled, switch back to the normal DO mode.

<b>P2.009</b>	<b>DI response filter time</b>		<b>Address: 0212H 0213H</b>
Default:	2	Control mode:	All
Unit:	ms	Setting range:	0 to 100
Format:	DEC	Data size:	16-bit

Settings:

When environmental interference is high, increasing this value can enhance the control stability. If you set the value too high, it affects the response time.

<b>P2.010</b>	<b>DI1 functional planning</b>		<b>Address: 0214H 0215H</b>
Default:	0x0101 (A3-L, A3-M) 0x0100 (A3-F, A3-E)	Control mode:	All
Unit:	-	Setting range:	0x0000 - 0x015F (last two codes are DI codes)
Format:	HEX	Data size:	16-bit

Settings:



U Z YX

YX	Input function selection	Z	Input contact: A or B contact
-	-	U	Reserved

- YX: input function selection

Refer to Table 8.1.

- Z: input contact: A or B contact
  - 0: set this input contact to be normally closed (B contact)
  - 1: set this input contact to be normally open (A contact)

When these parameters are modified, re-start the servo drive to ensure it functions normally. Use P3.006 to change the source for the digital input signal, which can be either an external terminal block or the communication parameter P4.007.

8

<b>P2.011</b>	<b>DI2 functional planning</b>		<b>Address: 0216H 0217H</b>
Default:	0x0104 (A3-L, A3-M) 0x0100 (A3-F, A3-E)	Control mode:	All
Unit:	-	Setting range:	0x0000 - 0x015F (last two codes are DI codes)
Format:	HEX	Data size:	16-bit

Settings:

Refer to the description of P2.010.

<b>P2.012</b>	<b>DI3 functional planning</b>		<b>Address: 0218H 0219H</b>
Default:	0x0116 (A3-L, A3-M) 0x0100 (A3-F, A3-E)	Control mode:	All
Unit:	-	Setting range:	0x0000 - 0x015F (last two codes are DI codes)
Format:	HEX	Data size:	16-bit

Settings:

Refer to the description of P2.010.

<b>P2.013</b>	<b>DI4 functional planning</b>		<b>Address: 021AH 021BH</b>
Default:	0x0117 (A3-L, A3-M) 0x0124 (A3-F, A3-E)	Control mode:	All
Unit:	-	Setting range:	0x0000 - 0x015F (last two codes are DI codes)
Format:	HEX	Data size:	16-bit

Settings:

Refer to the description of P2.010.

<b>P2.014</b>	<b>DI5 functional planning</b>		<b>Address: 021CH 021DH</b>
Default:	0x0102 (A3-L, A3-M) 0x0022 (A3-F, A3-E)	Control mode:	All
Unit:	-	Setting range:	0x0000 - 0x015F (last two codes are DI codes)
Format:	HEX	Data size:	16-bit

Settings:

Refer to the description of P2.010.

<b>P2.015</b>	<b>DI6 functional planning</b>		<b>Address: 021EH 021FH</b>
Default:	0x0022 (A3-L, A3-M) 0x0023 (A3-F, A3-E)	Control mode:	All
Unit:	-	Setting range:	0x0000 - 0x015F (last two codes are DI codes)
Format:	HEX	Data size:	16-bit

Settings:

Refer to the description of P2.010.

<b>P2.016</b>	<b>DI7 functional planning</b>		<b>Address: 0220H 0221H</b>
Default:	0x0023 (A3-L, A3-M) 0x0021 (A3-F, A3-E)	Control mode:	All
Unit:	-	Setting range:	0x0000 - 0x015F (last two codes are DI codes)
Format:	HEX	Data size:	16-bit

Settings:

Refer to the description of P2.010.

<b>P2.017</b>	<b>DI8 functional planning</b>		<b>Address: 0222H 0223H</b>
Default:	0x0021 (A3-L, A3-M) 0x0100 (A3-F, A3-E)	Control mode:	All
Unit:	-	Setting range:	0x0000 - 0x015F (last two codes are DI codes)
Format:	HEX	Data size:	16-bit

Settings:

Refer to the description of P2.010.

There is no physical pin for DI8 on A3-F and A3-E models. DI8 is a virtual digital input which you can use when the number of physical DI points is insufficient or to trigger through communication. You can set the DI to be used as soon as power is on when the contact would be normally closed for virtual digital input, such as Servo On.



8

P2.018	DO1 functional planning		Address: 0224H 0225H
Default:	0x0101	Control mode:	All
Unit:	-	Setting range:	0x0000 - 0x014F (last two codes are DO codes)
Format:	HEX	Data size:	16-bit

Settings:



U Z YX

YX	Output function selection	Z	Output contact: A or B contact
-	-	U	Reserved

- YX: output function selection  
Refer to Table 8.2.
- Z: output contact: A or B contact  
0: set this output contact to be normally closed (B contact)  
1: set this output contact to be normally open (A contact)

When these parameters are modified, re-start the servo drive to ensure it functions normally.

P2.019	DO2 functional planning		Address: 0226H 0227H
Default:	0x0103 (A3-L, A3-M) 0x0100 (A3-F, A3-E)	Control mode:	All
Unit:	-	Setting range:	0x0000 - 0x014F (last two codes are DO codes)
Format:	HEX	Data size:	16-bit

Settings:

Refer to the description of P2.018.

P2.020	DO3 functional planning		Address: 0228H 0229H
Default:	0x0109 (A3-L, A3-M) 0x0100 (A3-F, A3-E)	Control mode:	All
Unit:	-	Setting range:	0x0000 - 0x014F (last two codes are DO codes)
Format:	HEX	Data size:	16-bit

Settings:

Refer to the description of P2.018.

<b>P2.021</b>	<b>DO4 functional planning</b>		<b>Address: 022AH 022BH</b>
Default:	0x0105 (A3-L, A3-M) 0x0007 (A3-F, A3-E)	Control mode:	All
Unit:	-	Setting range:	0x0000 - 0x014F (last two codes are DO codes)
Format:	HEX	Data size:	16-bit

Settings:

Refer to the description of P2.018.

<b>P2.022</b>	<b>DO5 functional planning</b>		<b>Address: 022CH 022DH</b>
Default:	0x0007 (A3-L, A3-M) 0x0100 (A3-F, A3-E)	Control mode:	All
Unit:	-	Setting range:	0x0000 - 0x014F (last two codes are DO codes)
Format:	HEX	Data size:	16-bit

Settings:

Refer to the description of P2.018.

<b>P2.023</b>	<b>Notch filter 1 - frequency</b>		<b>Address: 022EH 022FH</b>
Default:	1000	Control mode:	All
Unit:	Hz	Setting range:	50 to 5000
Format:	DEC	Data size:	16-bit

Settings:

The resonance frequency of the first Notch filter. This function is disabled if P2.024 is 0. P2.023, P2.024, and P2.095 are the first set of Notch filter parameters.

<b>P2.024</b>	<b>Notch filter 1 - attenuation level</b>		<b>Address: 0230H 0231H</b>
Default:	0	Control mode:	All
Unit:	-dB	Setting range:	0 to 40
Format:	DEC	Data size:	16-bit

Settings:

The attenuation level of the first Notch filter. A value of 5 indicates -5 dB. Set this parameter to 0 to disable the first Notch filter.

## 8

P2.025	Resonance suppression low-pass filter			Address: 0232H 0233H
Operation interface:	Panel / software	Communication	Control mode:	All
Default:	1.0	10	Data size:	16-bit
Unit:	1 ms	0.1 ms	-	-
Setting range:	0.0 to 100.0	0 to 1000	-	-
Format:	One decimal	DEC	-	-
Example:	1.5 = 1.5 ms	15 = 1.5 ms	-	-

## Settings:

Sets the time constant for the low-pass filter for resonance suppression. Set this parameter to 0 to disable the low-pass filter.

P2.026	Anti-interference gain		Address: 0234H 0235H
Default:	0	Control mode:	PT / PR / S / Sz
Unit:	rad/s	Setting range:	0 to 1023
Format:	DEC	Data size:	16-bit

## Settings:

Increasing this parameter can increase the damping of the speed loop and reduce the speed loop response. Setting the value of P2.026 to the same value as P2.006 is recommended. See the following for setting P2.026:

1. In Speed mode, increase the value of this parameter to reduce speed overshoot.
2. In Position mode, decrease the value of this parameter to reduce position overshoot.

Note: this gain parameter is disabled when the two degree of freedom control function is on (P2.094 [Bit 12] = 1).

P2.027	Gain switching condition and method selection		Address: 0236H 0237H
Default:	0x0000	Control mode:	Refer to X: gain switching condition
Unit:	-	Setting range:	0x0000 - 0x0018
Format:	HEX	Data size:	16-bit

Settings:



X	Gain switching condition	Z	Reserved
Y	Gain switching method	U	Reserved

■ X: gain switching condition

X	Condition	Control mode	P1.078 (Gain switching delay time)
0	Disable gain switching function.	-	-
1	Signal of gain switching (DI.GAINUP: 0x03) is on.	All	-
2	In Position control mode, position error is larger than P2.029.	PT / PR	-
3	Frequency of Position command is larger than P2.029.	PT / PR	Supported
4	Speed of servo motor is faster than P2.029.	All	-
5	Signal of gain switching (DI.GAINUP: 0x03) is off.	All	-
6	In Position control mode, position error is smaller than P2.029.	PT / PR	-
7	Frequency of Position command is smaller than P2.029.	PT / PR	Supported
8	Speed of servo motor is slower than P2.029.	All	-

■ Y: gain switching method

0: gain rate switching

1: integrator switching (switch from P controller to PI controller)

PT / PR			
Y = 0		Y = 1	
Before switching	After switching	Before switching	After switching
P2.000 x 100%	P2.000 x P2.001	P2.000 x 100%	P2.000 x P2.001
P2.004 x 100%	P2.004 x P2.005	P2.004 x 100%	P2.004 x 100%
P2.025 x 100%	P2.025 x P2.107	P2.025 x 100%	P2.025 x P2.107
P2.026 x 100%	P2.026 x 100%	P2.026 x 0%	P2.026 x 100%
P2.049 x 100%	P2.049 x P1.080	P2.049 x 100%	P2.049 x P1.080

When P2.027.X is set to 0, 1, 2, 4, 5, 6, or 8, P1.078 (Gain switching delay time) is not supported.

P2.027.X = 4 is taken as the example in the following figure.

**P2.027.X = 4**

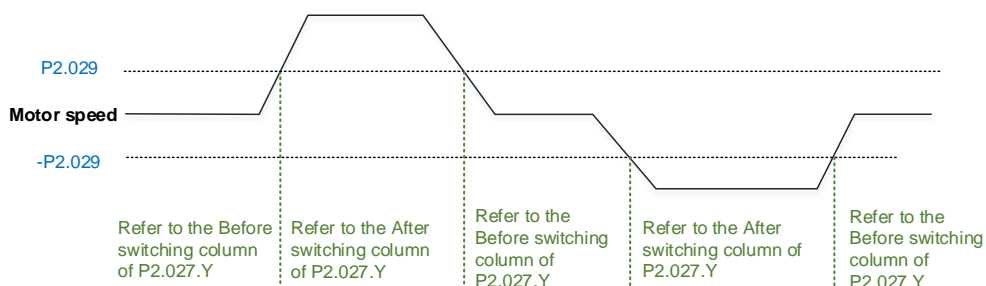

8

When P2.027.X is set to 3 or 7 and P1.078 (Gain switching delay time) is set, the gain parameter during the delay time is shown as follows.

**P2.027.X = 3**

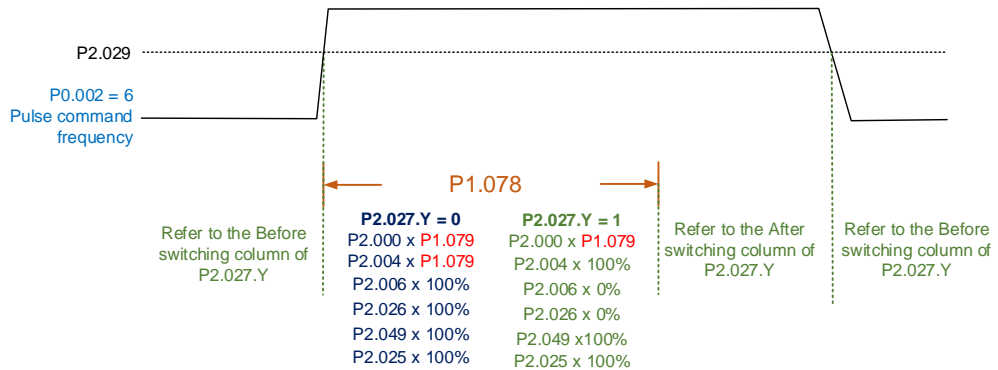

**P2.027.X = 7**

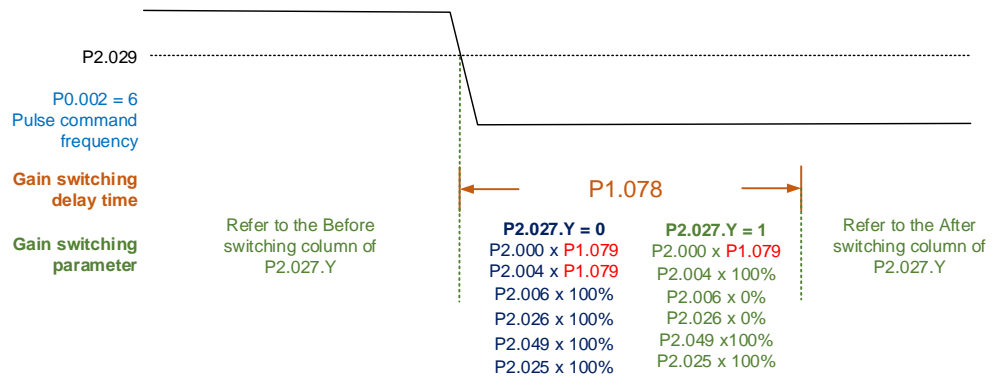

P2.028	Gain switching time constant		Address: 0238H 0239H
Default:	10	Control mode:	Refer to P2.027.X: gain switching condition
Unit:	ms	Setting range:	0 to 1000
Format:	DEC	Data size:	16-bit

Settings:

Smooths the speed of gain switching (P2.027). Set this parameter to 0 to disable this function.

P2.029	Gain switching condition		Address: 023AH 023BH
Default:	16777216	Control mode:	Refer to P2.027.X: gain switching condition
Unit:	pulse; Kpps; rpm (mm/s)	Setting range:	0 to 50331648
Format:	DEC	Data size:	32-bit

Settings:

The unit of this setting value is determined by the selection of gain switching condition (P2.027.X).

<b>P2.030</b>	<b>Auxiliary function</b>		<b>Address: 023CH 023DH</b>	
Default:	0	Control mode:	All	
Unit:	-	Setting range:	-8 to +8	
Format:	DEC	Data size:	16-bit	

Settings:

Value	Function
0	Disable all functions described as follows.
1	Switch servo to Servo On state.
5	This setting makes all parameter settings volatile. When there is no need to permanently save the data continually written through the panel or communication, this setting can avoid shortening the lifetime of the EEPROM from continuous parameter writing. You must set this parameter when using communication control.
6	This setting enables command simulation mode. In this mode, use the DI/O in ASDA-Soft to switch the servo to the Servo On state as both the external Servo On signal and the force Servo On of the PR mode in ASDA-Soft cannot work, the DSP Error (variable 0x6F) is read as 0, and P0.001 only shows the external error code (positive / negative limit, emergency stop). When DO.SRDY is on, commands are accepted in each mode. You can use the scope of the software to observe these commands to examine their accuracy, but the motor does not operate.
8	Back up all current parameter values to EEPROM, so that the values are retained after power cycling. The panel displays 'to.rom' during execution. This feature can also be executed when servo is in the Servo On state.
-1, -5, -6	Disable the functions of P2.030 = 1, 5, and 6.
-2 to -4, -7, -8, 2 to 4, 7	Reserved.

Note: set the value to 0 during normal operation. The value returns to 0 automatically after power cycling of the servo drive.

<b>P2.031</b>	<b>Bandwidth response level</b>		<b>Address: 023EH 023FH</b>	
Default:	19	Control mode:	All	
Unit:	-	Setting range:	1 to 50	
Format:	DEC	Data size:	16-bit	

Settings:

In gain adjustment mode (P2.032), adjust the servo bandwidth with the bandwidth response level parameter (P2.031). When you increase the bandwidth response level (P2.031), the servo bandwidth increases as well. Refer to Chapter 5 for adjustment details.

<b>P2.032</b>	<b>Gain adjustment mode</b>		<b>Address: 0240H 0241H</b>	
Default:	0x0001	Control mode:	All	
Unit:	-	Setting range:	0x0000 - 0x0006	
Format:	HEX	Data size:	16-bit	

Settings:

The servo drive provides the following gain adjustment modes for fine tuning. You can then easily complete tuning by increasing or decreasing the bandwidth response level (P2.031). Recommendations for tuning the machine are in Section 5.1.

Value	Adjustment mode	Inertia estimation	Parameter	
			Manual	Auto
0	Manual	Fixed set value of P1.037	P1.037, P2.000, P2.004, P2.006, P2.023, P2.024, P2.025, P2.043, P2.044, P2.045, P2.046, P2.049, P2.089, P2.098, P2.099, P2.101, P2.102	N/A
1	Gain adjustment mode 1	Real-time estimation	P2.031	P1.037, P2.000, P2.004, P2.006, P2.023, P2.024, P2.025, P2.043, P2.044, P2.045, P2.046, P2.049, P2.089, P2.098, P2.099, P2.101, P2.102
2	Gain adjustment mode 2	Fixed set value of P1.037	P1.037 P2.031	P2.000, P2.004, P2.006, P2.023, P2.024, P2.025, P2.043, P2.044, P2.045, P2.046, P2.049, P2.089, P2.098, P2.099, P2.101, P2.102
3	Gain adjustment mode 3 (only when the two degree of freedom control function is enabled)	Fixed set value of P1.037	P1.037 P2.031 P2.089	P2.000, P2.004, P2.006, P2.023, P2.024, P2.025, P2.043, P2.044, P2.045, P2.046, P2.049, P2.089, P2.098, P2.099, P2.101, P2.102
4	Gain adjustment mode 4	Reset to gain default value	-	-
5	Gain adjustment mode 5 (same as setting P2-32 to 1 for A2 series)	Real-time estimation; the result is updated to P1.037 every 30 minutes	P2.126	P1.037, P2.000, P2.004, P2.006, P2.023, P2.024, P2.025, P2.043, P2.044, P2.045, P2.046, P2.049, P2.089, P2.094, P2.098, P2.099, P2.101, P2.102
6	Gain adjustment mode 6 (same as setting P2-32 to 2 for A2 series)	Fixed set value of P1.037	P1.037 P2.126	P2.000, P2.004, P2.006, P2.023, P2.024, P2.025, P2.043, P2.044, P2.045, P2.046, P2.049, P2.089, P2.094, P2.098, P2.099, P2.101, P2.102

Note: when the two degree of freedom control function is disabled (P2.094 [Bit 12] = 0), the effect of gain adjustment mode 3 is equivalent to that of gain adjustment mode 2, so setting P2.089 is invalid in that scenario.

<b>P2.033</b>	<b>Reserved</b>
---------------	-----------------

<b>P2.034</b>	<b>Excessive deviation warning condition of Speed command</b>	<b>Address: 0244H 0245H</b>
Default:	5000	Control mode: S / Sz
Unit:	1 rpm (rotary)* 1 mm/s (linear)*	Setting range: 1 to 30000 (rotary)* 1 to 15999 (linear)*
Format:	DEC	Data size: 16-bit

## Settings:

In Speed mode, this parameter sets the acceptable difference between the command speed and the feedback speed. If the difference is greater than this value, AL007 occurs.

Note: when P2.094 [Bit 6] = 1, this parameter is available in both Position mode (PT, PR) and Speed mode (S, Sz).

<b>P2.035</b>	<b>Excessive deviation warning condition of Position command</b>	<b>Address: 0246H 0247H</b>
Default:	50331648	Control mode: PT / PR
Unit:	pulse	Setting range: 1 to 1677721600
Format:	DEC	Data size: 32-bit

## Settings:

In Position mode, this parameter sets the acceptable difference between the command position and the feedback position. If the difference is greater than this value, AL009 occurs.

<b>P2.036</b>	<b>DI9 functional planning</b>	<b>Address: 0248H 0249H</b>
Default:	0x0100	Control mode: All
Unit:	-	Setting range: 0x0000 - 0x015F (last two codes are DI codes)
Format:	HEX	Data size: 16-bit

## Settings:

Refer to the description of P2.010. If there is no physical pin for DI9 on the model, use DI9 as a virtual digital input when the number of physical DI points is insufficient or a trigger through communication. You can set the DI to be used as soon as the servo power is on (e.g. Servo On) to be a virtual DI and normally closed.



8

<b>P2.037</b>	<b>DI10 functional planning</b>		<b>Address: 024AH 024BH</b>
Default:	0x0100	Control mode:	All
Unit:	-	Setting range:	0x0000 - 0x015F (last two codes are DI codes)
Format:	HEX	Data size:	16-bit

Settings:

Refer to the description of P2.010. If there is no physical pin for DI10 on the model, use DI10 as a virtual digital input when the number of physical DI points is insufficient or a trigger through communication.

You can set the DI to be used as soon as the servo power is on (e.g. Servo On) to be a virtual DI and normally closed.

<b>P2.038</b>	<b>DI11 functional planning</b>		<b>Address: 024CH 024DH</b>
Default:	0x0100	Control mode:	All
Unit:	-	Setting range:	0x0000 - 0x015F (last two codes are DI codes)
Format:	HEX	Data size:	16-bit

Settings:

Refer to the description of P2.010. If there is no physical pin for DI11 on the model, use DI11 as a virtual digital input when the number of physical DI points is insufficient or a trigger through communication.

You can set the DI to be used as soon as the servo power is on (e.g. Servo On) to be a virtual DI and normally closed.

<b>P2.039</b>	<b>DI12 functional planning</b>		<b>Address: 024EH 024FH</b>
Default:	0x0100	Control mode:	All
Unit:	-	Setting range:	0x0000 - 0x015F (last two codes are DI codes)
Format:	HEX	Data size:	16-bit

Settings:

Refer to the description of P2.010. If there is no physical pin for DI12 on the model, use DI12 as a virtual digital input when the number of physical DI points is insufficient or a trigger through communication.

You can set the DI to be used as soon as the servo power is on (e.g. Servo On) to be a virtual DI and normally closed.

<b>P2.040</b>	<b>DI13 functional planning</b>		<b>Address: 0250H 0251H</b>	
Default:	0x0100	Control mode:	All	
Unit:	-	Setting range:	0x0000 - 0x015F (last two codes are DI codes)	
Format:	HEX	Data size:	16-bit	

Settings:

Refer to the description of P2.010. If there is no physical pin for DI13 on the model, use DI13 as a virtual digital input when the number of physical DI points is insufficient or a trigger through communication.

You can set the DI to be used as soon as the servo power is on (e.g. Servo On) to be a virtual DI and normally closed.

<b>P2.041</b>	<b>DO6 functional planning</b>		<b>Address: 0252H 0253H</b>	
Default:	0x0100	Control mode:	All	
Unit:	-	Setting range:	0x0000 - 0x013F (last two codes are DO codes)	
Format:	HEX	Data size:	16-bit	

Settings:

Refer to the description of P2.018.

<b>P2.042</b>	<b>Reserved</b>			
---------------	-----------------	--	--	--

<b>P2.043</b>	<b>Notch filter 2 - frequency</b>		<b>Address: 0256H 0257H</b>	
Default:	1000	Control mode:	All	
Unit:	Hz	Setting range:	50 to 5000	
Format:	DEC	Data size:	16-bit	

Settings:

The resonance frequency of the second Notch filter. This function is disabled if P2.044 is 0. P2.043, P2.044, and P2.096 are the second set of Notch filter parameters.

<b>P2.044</b>	<b>Notch filter 2 - attenuation level</b>		<b>Address: 0258H 0259H</b>	
Default:	0	Control mode:	All	
Unit:	-dB	Setting range:	0 to 40	
Format:	DEC	Data size:	16-bit	

Settings:

The attenuation level of the second Notch filter. A value of 5 indicates -5 dB. Set this parameter to 0 to disable the second Notch filter.

8

<b>P2.045</b>	<b>Notch filter 3 - frequency</b>		<b>Address: 025AH 025BH</b>	
Default:	1000	Control mode:	All	
Unit:	Hz	Setting range:	50 to 5000	
Format:	DEC	Data size:	16-bit	

Settings:

The resonance frequency of the third Notch filter. This function is disabled if P2.046 is 0. P2.045, P2.046, and P2.097 are the third set of Notch filter parameters.

<b>P2.046</b>	<b>Notch filter 3 - attenuation level</b>		<b>Address: 025CH 025DH</b>	
Default:	0	Control mode:	All	
Unit:	-dB	Setting range:	0 to 40	
Format:	DEC	Data size:	16-bit	

Settings:

The attenuation level of the third Notch filter. A value of 5 indicates -5 dB. Set this parameter to 0 to disable the third Notch filter.

<b>P2.047</b>	<b>Auto resonance suppression mode</b>		<b>Address: 025EH 025FH</b>	
Default:	0x0001	Control mode:	All	
Unit:	-	Setting range:	0x0000 - 0x01F2	
Format:	HEX	Data size:	16-bit	

Settings:



X	Auto resonance suppression function	Z	Fixed resonance suppression parameter
Y	Fixed resonance suppression parameter	U	Reserved

- X: auto resonance suppression function

0: disable auto resonance suppression. After the function is disabled, the existing resonance suppression parameter values do not change.

1: auto resonance suppression mode 1; when the servo determines it is stable\*2, the servo stores the known resonance suppression points to EEPROM (non-volatile memory for parameters) and disables the auto resonance suppression function (X = 0).

Before the servo is stable,

  - (1) If you cycle power on the servo drive, the found resonance suppression points are lost and will not be saved. The servo searches for the resonance suppression points again.
  - (2) If you switch the setting of X from 1 to 0, the known resonance suppression points will be stored to EEPROM.

(3) If you keep the setting of X as 1, the known resonance suppression points will not be cleared, but they are not written to EEPROM yet. They are written to EEPROM when the servo determines it is stable.

2: auto resonance suppression mode 2; when the servo determines it is stable\*2, the servo stores the known resonance suppression points to EEPROM (non-volatile memory for parameters). In this mode, the searching cycle continues until the 5 sets of resonance suppression parameters are set, and then the auto resonance suppression function is disabled (X = 0).

Before the servo is stable,

- (1) If you cycle power on the servo drive, the resonance suppression points that are not yet stored in EEPROM are lost and will not be saved. The resonance suppression points that have been stored in EEPROM will not be affected.
- (2) If you switch the setting of X from 2 to 0, the known resonance suppression points will be stored to EEPROM.
- (3) If you keep the setting of X as 2, the known resonance suppression points will not be cleared, but they are not written to EEPROM yet. They are written to EEPROM when the servo determines it is stable.

Note:

- 1. If you switch the setting of X from 0 to 1 or 2, the unfixed Notch filter is automatically cleared, the frequency is set to 1,000 Hz, and the suppression level is set to 0 dB.
- 2. The servo determines it is stable when the following conditions are met: resonances have been suppressed, no other interference that affects the operation is found, and the motor speed is maintained at above 10 rpm for 3 minutes.

■ Y: fixed resonance suppression parameter

In auto resonance suppression mode, you can set the resonance suppression parameters manually by setting P2.047.Y.

Bit	3	2	1	0
-----	---	---	---	---

Bit	Function	Description
0	Notch 1 auto / manual setting	0: auto resonance suppression 1: manually set the first set of resonance suppression parameters
1	Notch 2 auto / manual setting	0: auto resonance suppression 1: manually set the second set of resonance suppression parameters
2	Notch 3 auto / manual setting	0: auto resonance suppression 1: manually set the third set of resonance suppression parameters
3	Notch 4 auto / manual setting	0: auto resonance suppression 1: manually set the fourth set of resonance suppression parameters

8

- Z: fixed resonance suppression parameter

In auto resonance suppression mode, you can set the resonance suppression parameters manually by setting P2.047.Z.

Bit	3	2	1	0
-----	---	---	---	---

Bit	Function	Description
0	Notch 5 auto / manual setting	0: auto resonance suppression 1: manually set the fifth set of resonance suppression parameters
1 to 3	Reserved	-

Example: if P2.047 = 0x0021, the auto resonance suppression function is enabled, and the servo searches for the point of resonance and suppresses it. When you set Y to 2, you manually set the second set of resonance suppression parameters. Then, if the servo finds 2 resonance points, it writes the data of the 1<sup>st</sup> point to the 1<sup>st</sup> set of resonance suppression parameters and the data of the 2<sup>nd</sup> point to the 3<sup>rd</sup> set of resonance suppression parameters. That is, it skips the 2<sup>nd</sup> set of parameters.

P2.048	Auto resonance detection level			Address: 0260H 0261H
Default:	100	Control mode:	All	
Unit:	-	Setting range:	0 to 1000	
Format:	DEC	Data size:	16-bit	

Settings:

If P2.048 is larger, the resonance sensitivity is lower; on the other hand, if P2.048 is smaller, the resonance sensitivity is higher.

P2.049	Speed detection filter and jitter suppression			Address: 0262H 0263H
Operation interface:	Panel / software	Communication	Control mode:	All
Default:	1.0	10	Data size:	16-bit
Unit:	1 ms	0.1 ms	-	-
Setting range:	0.0 to 100.0	0 to 1000	-	-
Format:	One decimal	DEC	-	-
Example:	1.5 = 1.5 ms	15 = 1.5 ms	-	-

Settings:

Sets the filter for speed estimation. Adjusting this parameter can improve the extent of the speed jitter, but when the value is too high, the phase margin affecting the speed loop decreases, and thus makes the system unstable.

P2.050	Position error clear setting		Address: 0264H 0265H
Default:	0x0000	Control mode:	PT, PR
Unit:	-	Setting range:	0x0000 - 0x0001
Format:	HEX	Data size:	16-bit

Settings:

Refer to Table 8.1 for digital input descriptions. Set the digital input (DI: 0x04) as CCLR to enable this function.

When DI.CCLR is on, the position error in the servo drive is reset to 0.

P2.050 = 0: DI.CCLR is rising-edge triggered.

P2.050 = 1: DI.CCLR is level triggered.

P2.051	Reserved
--------	----------

P2.052 ▲	Rotary axis position scale		Address: 0268H 0269H
Default:	1073741824	Control mode:	PR
Unit:	PUU	Setting range:	32 to 1073741824
Format:	DEC	Data size:	32-bit

Settings:

Sets the scale of the rotary system, rotary axis command position, and rotary axis feedback position. If the value is too small, it may cause errors in the rotary system. The ranges of values for P2.052 are:

$$P2.052 > 1.05 \times \text{Maximum motor speed (rpm)} \times \frac{16777216}{60000} \times \frac{P1.045}{P1.044}$$

P2.053	Position integral compensation		Address: 026AH 026BH
Default:	0	Control mode:	PT / PR
Unit:	rad/s	Setting range:	0 to 1023
Format:	DEC	Data size:	16-bit

Settings:

Increase the position control integral compensation to reduce the position steady-state errors. If the value is too high, it may cause position overshoot and noise.

## 8

<b>P2.054 ▲</b>	<b>Synchronous speed control gain</b>		<b>Address: 026CH 026DH</b>
Default:	0	Control mode:	PT
Unit:	rad/s	Setting range:	0 to 8191
Format:	DEC	Data size:	16-bit

## Settings:

Increase the synchronous speed control gain to enhance the speed following between two motors. If the value is too high, it may cause vibration and noise.

<b>P2.055 ▲</b>	<b>Synchronous speed integral compensation</b>		<b>Address: 026EH 026FH</b>
Default:	0	Control mode:	PT
Unit:	rad/s	Setting range:	0 to 1023
Format:	DEC	Data size:	16-bit

## Settings:

Increase the synchronous speed integral compensation to enhance the speed following and reduce the speed errors between two motors. If the value is too high, it may cause vibration and noise.

<b>P2.056 ▲</b>	<b>Synchronous position integral compensation</b>		<b>Address: 0270H 0271H</b>
Default:	0	Control mode:	PT
Unit:	rad/s	Setting range:	0 to 1023
Format:	DEC	Data size:	16-bit

## Settings:

Increasing the synchronous position integral compensation can enhance the position following and reduce the position errors between two motors. If the value is too high, it may cause vibration and noise. It is recommended that you set this value to the same value as P2.006.

<b>P2.057 ▲</b>	<b>Synchronous control bandwidth</b>		<b>Address: 0272H 0273H</b>
Default:	0	Control mode:	PT
Unit:	Hz	Setting range:	0 to 1023
Format:	DEC	Data size:	16-bit

Settings:

If you are unsure about setting P2.054 - P2.056, set the value of synchronous control bandwidth instead so that the value corresponds to P2.054 - P2.056.

1. When the synchronous control bandwidth is greater than the servo bandwidth, the synchronous following is better.
2. When the servo bandwidth is greater than the synchronous control bandwidth, the single-axis motion following is better.

When the servo bandwidth plus the synchronous control bandwidth (P2.057) is greater than the system's allowable bandwidth, however, it causes system resonance.

Note: when increasing the bandwidth for both speed loop and synchronous control, ensure the response of P2.025 is much faster than the setting of both bandwidths. Therefore, decrease P2.025 as needed.

<b>P2.058</b>	<b>Synchronous speed error low-pass filter</b>		<b>Address: 0274H 0275H</b>
Default:	0	Control mode:	PT
Unit:	0.1 ms	Setting range:	0 to 1000
Format:	DEC	Data size:	16-bit
Example:	15 = 1.5 ms		

Settings:

When the synchronous control is affected by low resolution, meaning that noise (less sharp and rough sound) is generated, use low-pass filter suppression. This filter must be faster than the synchronous control bandwidth.

<b>P2.059</b>	<b>Reserved</b>



8

P2.060	E-Gear ratio - numerator N2		Address: 0278H 0279H
Default:	16777216	Control mode:	PT
Unit:	pulse	Setting range:	1 to (2 <sup>29</sup> -1)
Format:	DEC	Data size:	32-bit

Settings:

The numerator of the E-Gear ratio can be selected with DI.GNUM0 and DI.GNUM1 (refer to Table 8.1).

If both DI.GNUM0 and DI.GNUM1 are not defined, P1.044 is the default numerator of the E-Gear ratio.

Switch DI.GNUM0 and DI.GNUM1 only when the servo is stopped in order to avoid mechanical vibration.

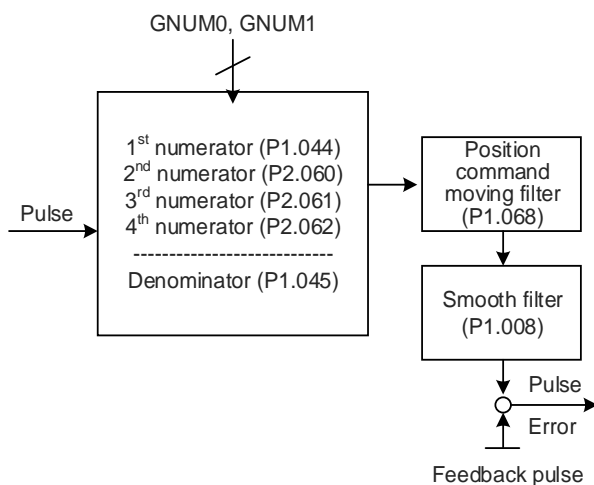

P2.061	E-Gear ratio - numerator N3		Address: 027AH 027BH
Default:	16777216	Control mode:	PT
Unit:	pulse	Setting range:	1 to (2 <sup>29</sup> -1)
Format:	DEC	Data size:	32-bit

Settings:

Refer to the description of P2.060.

P2.062	E-Gear ratio - numerator N4		Address: 027CH 027DH
Default:	16777216	Control mode:	PT
Unit:	pulse	Setting range:	1 to (2 <sup>29</sup> -1)
Format:	DEC	Data size:	32-bit

Settings:

Refer to the description of P2.060.

P2.063 - P2.064	Reserved
-----------------	----------

<b>P2.065</b>	<b>Special bit register 1</b>		<b>Address: 0282H 0283H</b>
Default:	0x0300	Control mode:	All
Unit:	-	Setting range:	0x0000 - 0xFFFF
Format:	HEX	Data size:	-

Settings:

Bit	7	6	5	4	3	2	1	0
Bit	15	14	13	12	11	10	9	8

Bit	Function	Description
Bit 0 - Bit 3	Reserved	-
Bit 4	Automatic friction estimation	<p>After enabling this function, you must conduct the continuous point-to-point motion to automatically write the estimated values to P1.062 and P1.063.</p> <p>0: disable the function. 1: enable the function.</p>
Bit 5	Switch for AL003 (Undervoltage) and AL022 (RST power error) in Servo Off status	<p>0: when the servo is off, disable the detection for AL003 (Undervoltage) and AL022 (RST power error). 1: when the servo is off, enable the detection for AL003 (Undervoltage) and AL022 (RST power error).</p>
Bit 6	Pulse error (pulse frequency is too high) protection function in PT mode	<p>0: enable the function. 1: disable the function.</p>
Bit 7	Reserved	-
Bit 8	Switch for motor power cable wiring error detection (AL031)	<p>0: disable the detection. 1: enable the detection.</p>
Bit 9	Switch for motor power cable disconnection detection (ALC31)	<p>0: disable the detection. 1: enable the detection.</p>
Bit 10	ZCLAMP function selection	<p>The ZCLAMP function is enabled when all the following conditions are met.</p> <p>Condition 1: Speed mode Condition 2: DI.ZCLAMP is on Condition 3: motor speed is slower than the value of P1.038</p>

8

Bit 10

Bit 10 = 0 and command source is the analog voltage.  
The ZCLAMP function uses the analog Speed command without acceleration or deceleration to determine if this function should be enabled. The motor is clamped at the position where ZCLAMP conditions are met.

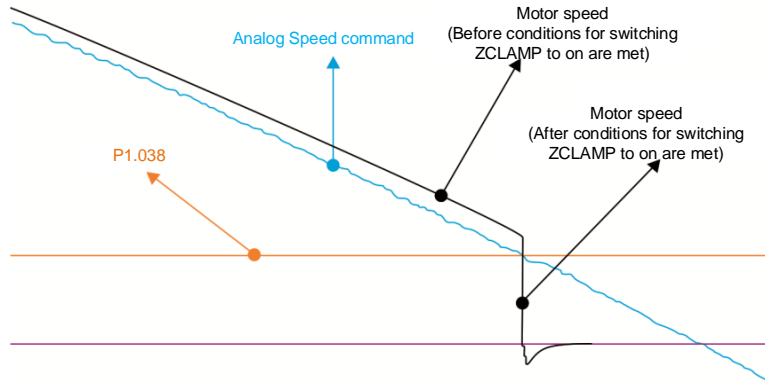

Bit 10 = 0 and command source is the internal register.  
The ZCLAMP function uses the register Speed command with acceleration or deceleration to determine if this function should be enabled. The motor is clamped at the position where ZCLAMP conditions are met.

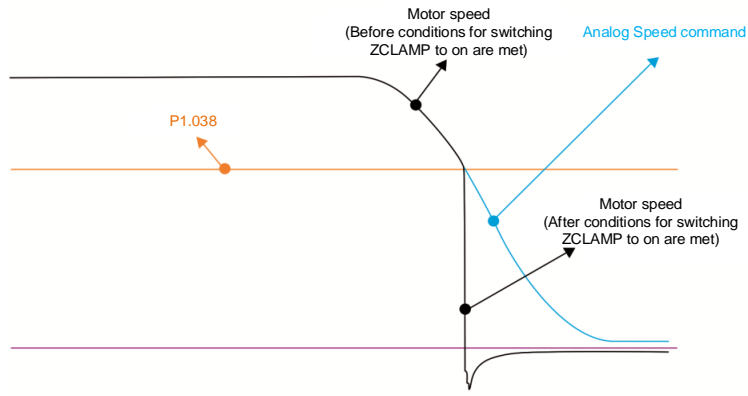

Bit 10 = 1 and command source is the analog voltage.  
The ZCLAMP function uses the analog Speed command without acceleration or deceleration to determine if this function should be enabled. When ZCLAMP conditions are met, the motor speed decelerates to 0 rpm by S-curve deceleration. If ZCLAMP conditions are not met, the motor follows the analog Speed command through the S-curve.

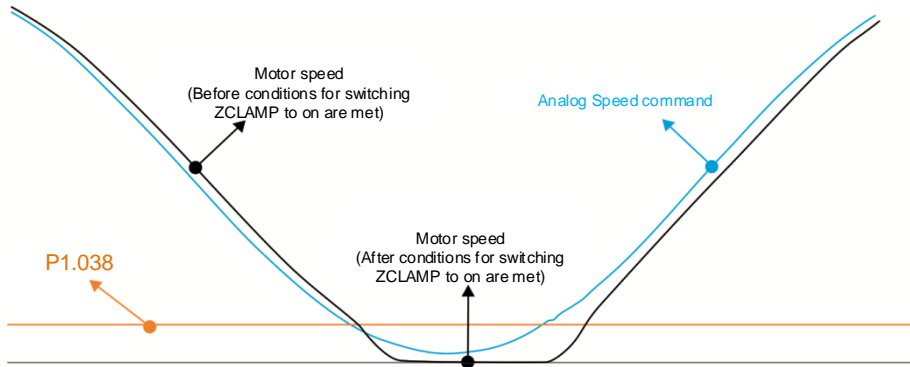

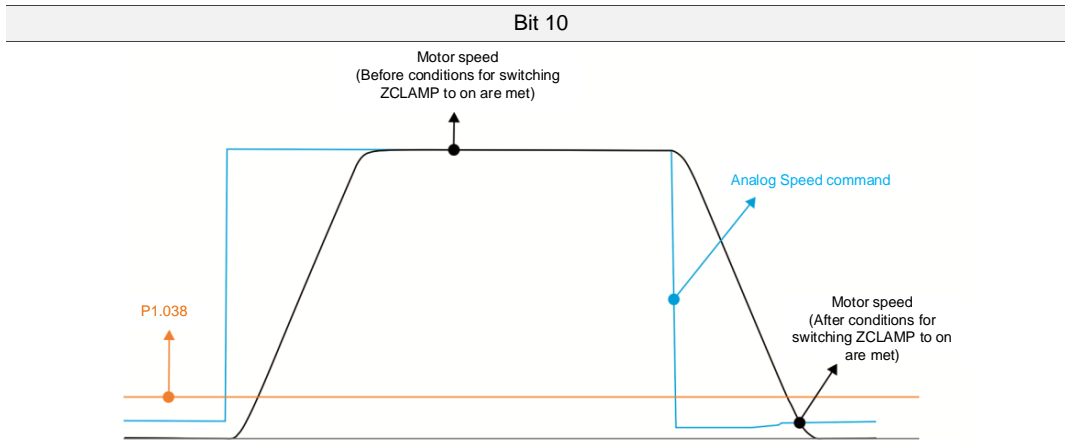

Bit 10 = 1 and command source is the internal register.  
 The ZCLAMP function uses the register Speed command with acceleration or deceleration to determine if this function should be enabled. When ZCLAMP conditions are met, the motor speed is set to 0 rpm.

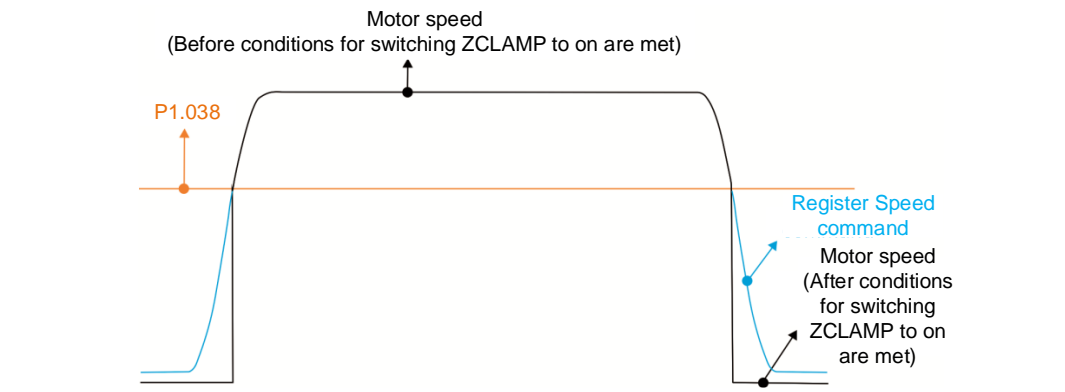

Bit	Function	Description
Bit 11	Pulse inhibit function switch in PT mode	0: disable PL / NL pulse inhibit function. In PT mode, the servo drive receives pulse position commands whether the motor reaches the PL or NL. 1: enable PL / NL pulse inhibit function. In PT mode, if the motor reaches the PL, the servo drive receives pulse position commands for negative-direction operation and stops receiving pulse position commands for positive-direction operation. In PT mode, if the motor reaches the NL, the servo drive receives pulse position commands for positive-direction operation and stops receiving pulse position commands for negative-direction operation.
Bit 12	RST power error (AL022) detection function	0: enable the RST power error (AL022) detection function. 1: disable the RST power error (AL022) detection function.
Bit 13	Switch for OA and OB output error (AL018 / AL048) detection	0: enable OA and OB output error (AL018 / AL048) detection. 1: disable OA and OB output error (AL018 / AL048) detection.
Bit 14, Bit 15	Reserved	-

8

<b>P2.066</b>	<b>Special bit register 2</b>	<b>Address: 0284H 0285H</b>	
Default:	0x0020	Control mode:	All
Unit:	-	Setting range:	0x0000 - 0x187F
Format:	HEX	Data size:	16-bit

Settings:

Bit	7	6	5	4	3	2	1	0
Bit	15	14	13	12	11	10	9	8

Bit	Function	Description
Bit 0, Bit 1	Reserved	-
Bit 2	Disable the AL003 (Undervoltage) latch	0: latch enabled; the undervoltage error is not cleared automatically. 1: latch disabled; the undervoltage error is cleared automatically.
Bit 3	Reserved	-
Bit 4	Disable the detection for AL044 (Servo function overload warning)	0: enable the detection. 1: disable the detection.
Bit 5	Enable the detection for AL041 (CN5 is disconnected)	0: disable the detection. 1: enable the detection.
Bit 6	RST power error (AL022) latch	0: disable the latch; RST power error (AL022) is cleared automatically. 1: enable the latch; RST power error (AL022) is not cleared automatically.
Bit 7, Bit 8	Reserved	-
Bit 9	Set AL003 (Undervoltage) as ALM or WARN	0: WARN. 1: ALM.
Bit 10, Bit 11	Reserved	-
Bit 12	Set AL022 (RST power error) as ALM or WARN	0: WARN. 1: ALM.
Bit 13 - Bit 15	Reserved	-

Note: when the full-closed loop function is enabled, the detection for AL041 (CN5 is disconnected) is disabled by default (P2.066 [Bit 5] = 0). It is strongly recommended that you enable this function when the servo is in the full-closed loop mode.

<b>P2.067</b>	<b>Reserved</b>
---------------	-----------------

<b>P2.068</b>	<b>Following error compensation switch</b>		<b>Address: 0288H 0289H</b>
Default:	0x00000000	Control mode:	PR / CANopen / EtherCAT / DMCNET
Unit:	-	Setting range:	0x00000000 - 0x00002101
Format:	HEX	Data size:	32-bit

Settings:



A	Reserved	X	Following error compensation switch
B	Reserved	Y	Reserved
C	Reserved	Z	DI.STP triggering method
D	Reserved	U	CANopen / EtherCAT PV mode unit selection

- X: following error compensation switch (functions under the condition of P1.036 > 1)
  - 0: disable following error compensation
  - 1: enable following error compensation
- Z: DI.STP triggering method
  - 0: rising-edge triggering
  - 1: level triggering
- U: CANopen / EtherCAT PV mode unit selection
  - 0: 0.1 rpm
  - 1: 0.01 rpm

Note: when you change the setting of P2.068.U, the units of OD 606Bh, OD 606Ch, OD 60FFh, and P5.003 (Deceleration time for auto-protection) in bus communication mode will change as well (when P2.068.U = 1, the units of P5.020 - P5.035 are defined as 10 ms). Make sure the setting values are correct.

<b>P2.069●</b>	<b>Absolute encoder</b>		<b>Address: 028AH 028BH</b>
Default:	0x0000	Control mode:	All
Unit:	-	Setting range:	0x0000 - 0x1211
Format:	HEX	Data size:	16-bit

Settings:



X	Operation mode setting	Z	Function of preventing rotary axis position loss when overflow occurs
Y	Pulse command setting when absolute position is lost	U	Single-turn absolute function

8

- X: operation mode setting

0: incremental mode. An absolute type motor can be operated as an incremental type motor.

1: absolute mode. This setting is only applicable to an absolute type motor. If it is used for an incremental type motor, AL069 occurs.
- Y: pulse command setting when absolute position is lost

0: when AL060 or AL06A occurs, the system cannot accept a pulse command.

1: when AL060 or AL06A occurs, the system can accept a pulse command.
- Z: function of preventing rotary axis position offset when overflow occurs

0: when the number of revolutions of the encoder overflows, the absolute position and rotary axis position are offset after power is off.

1: rotary axis position is not affected by overflow, but the absolute position is offset. It is recommended that you read the rotary axis position feedback (monitoring variable 091) (AL062, AL066, and AL289 do not function).

2: when the DVP-50MC series or AX series controller is used, rotary axis position is not affected by overflow, but the absolute position is offset. It is recommended that you read the rotary axis position feedback (monitoring variable 091) (AL062, AL066, and AL289 do not function).
- U: single-turn absolute function

0: disable the single-turn absolute function.

1: enable the single-turn absolute function and automatically set both P2.069.X and P2.069.Z to 1.

**Important: when you are using the single-turn absolute function, the motor must not rotate more than 1/4 revolution when power is off.**

Note: changes to this setting are effective only after power is cycled to the servo drive.

P2.070	Read data selection		Address: 028CH 028DH
Default:	0x0000	Control mode:	All
Unit:	-	Setting range:	0x0000 - 0x0007
Format:	HEX	Data size:	16-bit

Settings:

Bit	7	6	5	4	3	2	1	0
Bit	15	14	13	12	11	10	9	8

Bit	Function	Description
Bit 0	DI/DO data unit setting	0: PUU. 1: pulse.
Bit 1	Communication data unit setting	0: PUU. 1: pulse.
Bit 2	Overflow warning setting	0: the servo drive issues the overflow warnings AL289 (PUU) and AL062 (pulse). 1: no overflow warning.
Bit 3 - Bit 15	Reserved	-

# 8





<b>P2.071</b>	<b>Absolute position reset</b>		<b>Address: 028EH 028FH</b>
Default:	0x0000	Control mode:	All
Unit:	-	Setting range:	0x0000 - 0x0001
Format:	HEX	Data size:	16-bit

Settings:

Set P2.071 to 0x0001 to reset the current absolute position of the encoder. The clearing function is enabled by setting P2.008 to 271 and P2.069.X to 1.

<b>P2.072</b>	<b>Reserved</b>
---------------	-----------------

<b>P2.073</b>	<b>E-Cam: phase alignment operation setting</b>		<b>Address: 0292H 0293H</b>
Default:	0x00000000	Control mode:	PR
Unit:	-	Setting range:	0x00000000 - 0x5F3F6F5F
Format:	HEX	Data size:	32-bit

Settings:



BA	PR number	YX	Range of filter (0 - 95%)
DC	Masking range (0 - 95%)	UZ	Maximum allowable correction rate (0 - 100%)

- YX: range of filter (0 - 95%)

When DI.ALGN is triggered, the E-Cam phase alignment function is enabled. The system detects the current E-Cam position. When the difference (in percentage) between the current E-Cam position and its previous alignment position is less than the value set by the parameter, the filter function is enabled. Otherwise, the system uses the new position to do the alignment.

YX	Description
00	Filter disabled
01 - 5F	If $  \text{Error}   \leq (1 - \text{YX})\%$ , then the filter is enabled

Note: using the filter allows the alignment to be more stable and reduces any position errors caused by DI noise, so the operation can be smoother.

- UZ: maximum allowable correction rate (0 - 100%)

When phase alignment is enabled, the limitation of the maximum allowable correction rate (C) is defined as  $| C | \leq (P5.084/P5.083) \times P2.073.UZ \%$ .

Note: when the alignment error is too large, correcting this error once may cause motor vibration or overloading. Using this parameter can divide the phase alignment into several stages to smooth the process, but it may need more time to complete the phase alignment.

- BA: PR number (PR#0 - PR#99)

After each alignment, any shortage of pulse numbers from the slave axis is stored in a specified PR. This PR can compensate for the slave position at the appropriate timing point. If BA is set to 00, any shortage of pulse numbers is not stored in PR.

Note: the format of this parameter is HEX. Thus, to set PR#11, write 0B to BA.

- DC: masking range (0 - 95%)

When DI.ALGN is triggered, the next alignment action is allowed only after the increasing pulses of the master axis are greater than the masking distance (M).

$$M \geq (P5.084/P5.083) \times P2.073.DC \%$$

Note: this masking function only allows forward pulse input and does not work for reverse pulse input.

P2.074	E-Cam: DI delay time for phase alignment		Address: 0294H 0295H
Default:	0.000	Control mode:	PR
Unit:	ms (minimum scale is $\mu$ s)	Setting range:	-25.000 to +25.000 (includes 3 decimal places)
Format:	DEC	Data size:	16-bit

Settings:

This parameter offsets the alignment target to resolve DI and sensor delays. The setting works as follows:

$$P2.074 = P2.009 \text{ (DI response filter time)} + \text{sensor's delay time}$$

P2.075■	E-Cam: target position for phase alignment		Address: 0296H 0297H
Default:	0	Control mode:	PR
Unit:	Pulse unit of master axis	Setting range:	0 to (P5.084 / P5.083) - 1
Format:	DEC	Data size:	32-bit

Settings:

Sets the target position for E-Cam alignment; unit: pulse unit of master axis.

Note: when the input value is within the setting range, but it then exceeds the range due to changes in the value of P5.084 or P5.083, this parameter is automatically reset to 0.



<b>P2.076</b>	<b>E-Cam: phase alignment control switch</b>		<b>Address: 0298H 0299H</b>
Default:	0x0000	Control mode:	PR
Unit:	-	Setting range:	0x0000 - 0x6FF7
Format:	HEX	Data size:	16-bit

Settings:



X	E-Cam alignment control	UZ	Alignment forward direction allowable rate
Y	Filter intensity (0 - F)	-	-

- X: E-Cam alignment control

Bit	3	2	1	0
-----	---	---	---	---

Bit	Function	Description
0	Enable alignment	Set this bit to 0 to disable this function. Set this bit to 1 to enable this function. If this function is enabled, the E-Cam phase alignment is executed when DI.ALGN is on.
1	Trigger PR immediately	The E-Cam displacement value is stored in the PR specified by P2.073.BA. Set this bit to 1 to trigger this PR command immediately. Set this bit to 0 and it does not trigger this PR command immediately. Use the PR command after E-Cam disengages (P5.088.BA) to execute phase alignment.
2	Position of the mark	Set this bit to 0 if the mark is on a non-compensated motion axis, as the position of the mark is not affected during E-Cam phase alignment. Set this bit to 1 if the mark is on a compensated motion axis, as the position of the mark is affected during E-Cam phase alignment.
3	Reserved	-

- Y: filter intensity (0 - F)

Indicates average of  $2^Y$  (Y value). Set to 0 to disable the filter. When the value of Y increases, the correction is slower which can avoid large amounts of correction during E-Cam adjustment. This can also avoid disturbances caused by sensor noise for a smoother operation. Setting P2.076.Y too high causes the alignment to not work properly. The recommended value is 3.

Example:

When the filter intensity is set to 3, the actual filter intensity =  $2^3 = 8$ , which means that after capturing the error values 8 times, the servo takes the average of the 8 values for the correction value of the alignment.

- UZ: alignment forward direction allowable rate (0 - 100%)

Value	Alignment direction	Value	Alignment direction
0	Backward alignment only	80	Forward 80%, backward 20%
30	Forward 30%, backward 70%	$\geq 100$	Forward alignment only
50	Alignment with the shortest distance	-	-

<b>P2.077</b>	<b>E-Cam: pulse masking and virtual pulse for master axis</b>		<b>Address: 029AH 029BH</b>
Default:	0x0000	Control mode:	PR
Unit:	-	Setting range:	0x0000 - 0xFF7D
Format:	HEX	Data size:	16-bit

Settings:



X	Pulse masking function of master axis / pulse input method of master axis	UZ	Pulse data when master axis performs continuous forward / reverse running or JOG operation
Y	Masking pulse / virtual pulse for initial lead adjustment	-	-

- X: pulse masking function of master axis / pulse input method of master axis

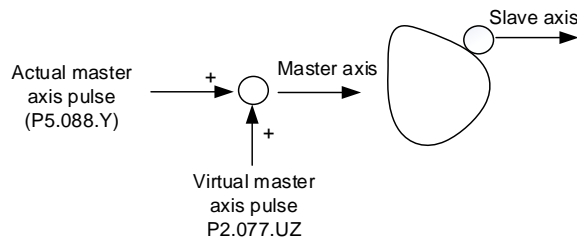

X	Function	Actual master axis pulse	Virtual master axis pulse	Description
0	Function disabled	Received	Disabled	Slave axis is driven by the actual master axis pulse.
1	Master axis pulse masked	Masked	Enabled	Slave axis stops operating, but the masked master axis pulse continues to be stored in the internal variable.
2	Continuous forward running			Command source is the virtual pulse frequency (unit: Kpps) set by P2.077.UZ. This function continues to operate. To stop the virtual pulse, set X to 1.
3	Continuous reverse running			Command source is the virtual pulse number (unit: pulse) set by P2.077.UZ. This function only refers to the pulse number set by P2.077.UZ.
4	Forward JOG			
5	Reverse JOG			
6 to 8	Reserved	-	-	-
9	Master axis pulse masked	Received	Enabled	Slave axis is driven by the actual master axis pulse and the master axis pulse continues to be stored in the internal variable.
A	Continuous forward running			Command source is the frequency transmitted by the actual master axis (P5.088.Y) plus the virtual pulse frequency (unit: Kpps) set by P2.077.UZ. This function continues to operate. To stop the virtual pulse, set X to 9.
B	Continuous reverse running			
C	Forward JOG			
D	Reverse JOG		Command source is the pulse transmitted by the actual master axis (P5.088.Y) plus the virtual pulse number (unit: pulse) set by P2.077.UZ. This function is often used for dynamic adjustment.	

8

- Y: masking pulse / virtual pulse for initial lead adjustment

Y	Function	Description
0	Function disabled	Virtual pulse number is not written to P5.087 (initial lead).
0→1	Write the lead	Write the virtual pulse number to P5.087 (initial lead).
0→2	Write to ROM	Write the virtual pulse number to P5.087 (initial lead) and also write to EEPROM.
0→3		
0→4	Plus one cycle	Write the virtual pulse number plus the pulse number of one cycle (P5.084 / P5.083) to P5.087 (initial lead).
0→5		
0→6	Plus one cycle and write to ROM	Write the virtual pulse number plus the pulse number of one cycle (P5.084 / P5.083) to P5.087 (initial lead) and also write to EEPROM.
0→7		
8 to 15	Reserved	-

Example:

Initial lead pulse P5.087 = 2000; pulse number of one cycle is 5000.

1. Virtual pulse number is 255. Set P2.077.Y to 1, and then  $P5.087 = 2000 + 255 = 2255$ .
2. Virtual pulse number is 255. Set P2.077.Y to 4, and then  $P5.087 = 2000 + 255 + 5000 = 7255$ .
3. Virtual pulse number is -2550. Set P2.077.Y to 5, and then  $P5.087 = 2000 - 2550 + 5000 = 4450$ .

- UZ: pulse data when master axis performs continuous forward / reverse running or JOG operation

Example:

Initiate masking of the actual pulse of master axis ► UZYX = 0x0001

Continuous forward running of master axis at 20 Kpps ► UZYX = 0x1402

Continuous reverse running of master axis at 32 Kpps ► UZYX = 0x2003

Forward JOG of master axis for 255 pulses ► UZYX = 0xFF04

Reverse JOG of master axis for 18 pulses ► UZYX = 0x1205

Complete and adjust for lead ► UZYX = 0x0020 (write to EEPROM)

Disable this function ► UZYX = 0x0000

P2.078	E-Cam: DO.CAM_AREA2 rising-edge phase		Address: 029CH 029DH
Default:	270	Control mode:	PR
Unit:	Degree	Setting range:	0 to 360
Format:	DEC	Data size:	16-bit

Settings:

See the correlation between DO.CAM\_AREA2 (DO: 0x1A) and the parameters in the following figure.

When E-Cam is not engaged, this signal is always off.

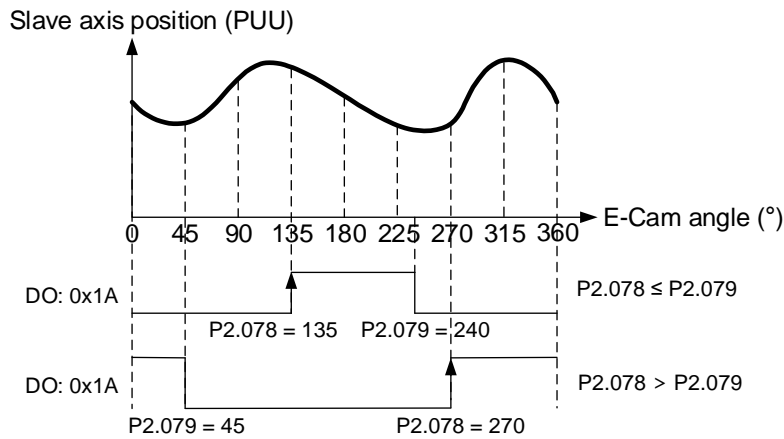

P2.079	E-Cam: DO.CAM_AREA2 falling-edge phase		Address: 029EH 029FH
Default:	360	Control mode:	PR
Unit:	Degree	Setting range:	0 to 360
Format:	DEC	Data size:	16-bit

Settings:

Refer to P2.078 for the correlation between DO.CAM\_AREA2 and the parameters.

P2.080	Z phase source of homing		Address: 02A0H 02A1H
Default:	0x0000	Control mode:	PR* (full-closed loop)
Unit:	-	Setting range:	0x0000 to 0x0011
Format:	HEX	Data size:	16-bit

Settings:

The full-closed loop control is realized by connecting the auxiliary encoder to CN5.

When you execute homing and have the servo look for the Z phase, use this parameter to set either the Z phase of the motor or the Z phase of the auxiliary encoder as the homing origin. (Select the auxiliary encoder to achieve higher positioning precision.)

After the full-closed loop function is enabled (P1.074.X = 1), restart and set the Capture function.

0002

U Z Y X

X	Z phase source of full-closed loop homing	Z	Reserved
Y	Z phase source of semi-closed loop homing	U	Reserved

- X: Z phase source of full-closed loop homing  
0: auxiliary encoder  
1: motor
- Y: Z phase source of semi-closed loop homing  
0: motor  
1: auxiliary encoder

Note: PR full-closed loop function is not yet supported.

P2.081	Pulse leakage detection function		Address: 02A2H 02A3H
Default:	1	Control mode:	All
Unit:	-	Setting range:	0 to 1
Format:	DEC	Data size:	16-bit

Settings:

Pulse leakage detection function switch. Set 0 to disable this function; set 1 to enable this function.

This parameter is only applicable to pulse motors and when PM.003.U is set to 1 (main encoder connects to CN5).

P2.082	Pulse leakage warning level		Address: 02A4H 02A5H
Default:	400	Control mode:	All
Unit:	pulse	Setting range:	0 to 32767
Format:	DEC	Data size:	16-bit

Settings:

When P2.081 is set to 1 and the number of pulse leakage exceeds this set value, AL057 is triggered.

This parameter is only applicable to pulse motors and when PM.003.U is set to 1 (main encoder connects to CN5).

<b>P2.083</b>	<b>Exceed Z signal detection</b>		<b>Address: 02A6H 02A7H</b>	
Default:	2000	Control mode:	All	
Unit:	pulse	Setting range:	0 to 2 <sup>31</sup> -1	
Format:	DEC	Data size:	32-bit	

Settings:

This parameter detects if the motor encounters a new Z signal when operating. It is suggested that you set this parameter as half the number of pulses between two Z signals.

This parameter is only applicable to pulse linear motors and when PM.003.U is set to 1 (main encoder connects to CN5). You can disregard this parameter if there is only one Z signal.

<b>P2.084</b>	<b>Special function for low resolution motor</b>		<b>Address: 02A8H 02A9H</b>	
Default:	0x0000	Control mode:	All	
Unit:	-	Setting range:	0x0000 to 0x311F	
Format:	HEX	Data size:	16-bit	

Settings:

Bit	7	6	5	4	3	2	1	0
-----	---	---	---	---	---	---	---	---

Bit	15	14	13	12	11	10	9	8
-----	----	----	----	----	----	----	---	---

**U**

Bit	Function	Description
Bit 0 - Bit 7	Reserved	-
Bit 8	Speed smoothing function	When the resolution of the motor is low, enable this function to smooth the uneven speed. This function is only applicable to pulse motors and when PM.003.U is set to 1 (main encoder connects to CN5). 0: disable 1: enable
Bit 9 - Bit 11	Reserved	-
U	Speed observer	When the resolution of the motor is low, enable this function to smooth the speed with a <b>filtering effect</b> . Before this function is enabled, it is suggested that you gradually lower the set value for P2.025 to avoid sacrificing the phase due to excessive filtering and thus resulting in resonance of the machine. 0: speed observer 1; the filter bandwidth is 1000/P2.049. 1: speed observer 2; the filter bandwidth cannot be adjusted. 2: speed observer 3; the filter bandwidth is 1000/P2.049. Note: 1. Speed observer 1 is applicable to high resolution encoders. 2. Speed observers 2 and 3 are applicable to encoders or linear scales with low resolution. For example, the single-turn resolution of the rotary encoder is smaller than 40000 pulse/rev and the application requires low speed (lower than 100 rpm), or the resolution of the linear encoder is greater than 5 μm/pulse.

<b>P2.085 - P2.087</b>	<b>Reserved</b>
------------------------	-----------------



8

P2.088	Motor special bit register		Address: 02B0H 02B1H
Default:	0x0000	Control mode:	PT / PR / S / Sz
Unit:	-	Setting range:	0x0000 to 0xFFFF
Format:	HEX	Data size:	16-bit

Settings:

Bit	7	6	5	4	3	2	1	0
Bit	15	14	13	12	11	10	9	8

Bit	Function	Description
Bit 0 - Bit 2	Reserved	-
Bit 3	Maintain the strength of the gain switch integrator	0: do not adjust the strength of the speed loop integrator. (Integrator strength = P2.004 x P2.005 x P2.006) 1: when the gain switching function (P2.027) is enabled, it can avoid reducing the integrator strength when the speed control gain (P2.004) is switched. (Integrator strength = P2.004 x P2.006)
Bit 4	Position pulse input is prohibited during initial magnetic field detection	This function is only available in PT mode. 0: receive position pulse normally. 1: position pulse input is prohibited until the initial magnetic field detection is complete.
Bit 5 - Bit 15	Reserved	-

P2.089	Command response gain		Address: 02B2H 02B3H
Default:	25	Control mode:	PT / PR
Unit:	rad/s	Setting range:	1 to 2000
Format:	DEC	Data size:	16-bit

Settings:

Increasing this gain speeds up the responsiveness of the Position command and shortens the settling time, but when the gain is too large, it causes position overshoot which leads to machine jitter.

Note: enable the two degree of freedom control function (P2.094 [Bit 12] = 1) before adjusting this parameter.

P2.090	Two degree of freedom mode - anti-interference gain		Address: 02B4H 02B5H
Default:	850	Control mode:	PT / PR
Unit:	0.001	Setting range:	500 to 1999
Format:	DEC	Data size:	16-bit

Settings:

This parameter improves the command response and fine tunes the overshoot when the command is settling. Set this parameter to a smaller value to reduce the occurrence of command overshoot. This parameter is only valid when the two degree of freedom control function is enabled (P2.094 [Bit 12] = 1) and its function is similar to that of P2.026.

<b>P2.091</b>	<b>Two degree of freedom mode - position feed forward gain</b>		<b>Address: 02B6H 02B7H</b>
Default:	1000	Control mode:	PT / PR
Unit:	0.1%	Setting range:	0 to 3000
Format:	DEC	Data size:	16-bit

Settings:

This parameter reduces the following error of the motor. If the value is set too high, it may cause overshoot during positioning. It is suggested that you set this parameter to the default value or only make small adjustments. This parameter is only valid when the two degree of freedom control function is enabled (P2.094 [Bit 12] = 1) and its function is similar to that of P2.002.

<b>P2.092</b>	<b>Two degree of freedom mode - speed feed forward gain</b>		<b>Address: 02B8H 02B9H</b>
Default:	1000	Control mode:	PT / PR
Unit:	0.1%	Setting range:	0 to 3000
Format:	DEC	Data size:	16-bit

Settings:

This parameter reduces the following error when the motor starts and stops. Use this parameter to roughly adjust the overshoot during positioning. Set this parameter to a larger value to reduce overshoot. This parameter is only valid when the two degree of freedom control function is enabled (P2.094 [Bit 12] = 1) and its function is similar to that of P2.007.

<b>P2.093</b>	<b>Reserved</b>
---------------	-----------------

<b>P2.094 ▲</b>	<b>Special bit register 3</b>		<b>Address: 02BCH 02BDH</b>
Default:	0x1090 (A3-M, A3-L, A3-E) 0x0090 (A3-F)	Control mode:	All
Unit:	-	Setting range:	0x0000 to 0xF3F6
Format:	HEX	Data size:	16-bit

Settings:

Bit	7	6	5	4	3	2	1	0
-----	---	---	---	---	---	---	---	---

Bit	15	14	13	12	11	10	9	8
-----	----	----	----	----	----	----	---	---

Bit	Function	Description
Bit 0 - Bit 3	Reserved	-
Bit 4	Dynamic brake options	0: disable new dynamic brake. 1: enable new dynamic brake.
Bit 5	Switch for AL016 (IGBT overheat)	0: enable AL016 (IGBT overheat). 1: disable AL016 (IGBT overheat).

Bit	Function	Description
Bit 6	Switch for AL007 detection in Position mode	Switch for AL007 detection in Position mode (PT and PR) 0: disable AL007 detection (default). 1: enable AL007 detection.
Bit 7	Switch for AL086	Switch for the brake resistor temperature protection when the input voltage is too high 0: disable. 1: enable.
Bit 8	First set of vibration elimination	This function is only available in Position mode (PT and PR); not available for linear motors. 0: disable first set of vibration elimination. 1: enable first set of vibration elimination (P1.089 - P1.091). Vibration elimination takes effect only when the two degree of freedom control function is enabled (P2.094 [Bit 12] = 1).
Bit 9	Second set of vibration elimination	This function is only available in Position mode (PT and PR); not available for linear motors. 0: disable second set of vibration elimination. 1: enable second set of vibration elimination (P1.092 - P1.094). Vibration elimination takes effect only when the two degree of freedom control function is enabled (P2.094 [Bit 12] = 1).
Bit 10, Bit 11	Reserved	-
Bit 12	Two degree of freedom control function	This function is only available in Position mode (PT and PR). 0: disable two degree of freedom control function (A2 and B2 models do not have this function.). 1: enable two degree of freedom control function.
Bit 13 - Bit 15	Reserved	-

P2.095	Notch filter 1 - Q factor		Address: 02BEH 02BFH
Default:	5	Control mode:	All
Unit:	-	Setting range:	1 to 10
Format:	DEC	Data size:	16-bit

## Settings:

The resonance Q factor of the first Notch filter. This function is disabled if P2.024 is 0. P2.023, P2.024, and P2.095 are the first set of Notch filter parameters.

P2.096	Notch filter 2 - Q factor		Address: 02C0H 02C1H
Default:	5	Control mode:	All
Unit:	-	Setting range:	1 to 10
Format:	DEC	Data size:	16-bit

## Settings:

The resonance Q factor of the second Notch filter. This function is disabled if P2.044 is 0. P2.043, P2.044, and P2.096 are the second set of Notch filter parameters.

<b>P2.097</b>	<b>Notch filter 3 - Q factor</b>		<b>Address: 02C2H 02C3H</b>	
Default:	5	Control mode:	All	
Unit:	-	Setting range:	1 to 10	
Format:	DEC	Data size:	16-bit	

## Settings:

The resonance Q factor of the third Notch filter. This function is disabled if P2.046 is 0. P2.045, P2.046, and P2.097 are the third set of Notch filter parameters.

<b>P2.098</b>	<b>Notch filter 4 - frequency</b>		<b>Address: 02C4H 02C5H</b>	
Default:	1000	Control mode:	All	
Unit:	Hz	Setting range:	50 to 5000	
Format:	DEC	Data size:	16-bit	

## Settings:

The resonance frequency of the fourth Notch filter. This function is disabled if P2.099 is 0. P2.098, P2.099, and P2.100 are the fourth set of Notch filter parameters.

<b>P2.099</b>	<b>Notch filter 4 - attenuation level</b>		<b>Address: 02C6H 02C7H</b>	
Default:	0	Control mode:	All	
Unit:	-dB	Setting range:	0 to 40	
Format:	DEC	Data size:	16-bit	

## Settings:

The attenuation level of the fourth Notch filter. A value of 5 indicates -5 dB. Set this parameter to 0 to disable the fourth Notch filter.

<b>P2.100</b>	<b>Notch filter 4 - Q factor</b>		<b>Address: 02C8H 02C9H</b>	
Default:	5	Control mode:	All	
Unit:	-	Setting range:	1 to 10	
Format:	DEC	Data size:	16-bit	

## Settings:

The resonance Q factor of the fourth Notch filter. This function is disabled if P2.099 is 0. P2.098, P2.099, and P2.100 are the fourth set of Notch filter parameters.

## 8

<b>P2.101</b>	<b>Notch filter 5 - frequency</b>		<b>Address: 02CAH 02CBH</b>	
Default:	1000	Control mode:	All	
Unit:	Hz	Setting range:	50 to 5000	
Format:	DEC	Data size:	16-bit	

## Settings:

The resonance frequency of the fifth Notch filter. This function is disabled if P2.102 is 0. P2.101, P2.102, and P2.103 are the fifth set of Notch filter parameters.

<b>P2.102</b>	<b>Notch filter 5 - attenuation level</b>		<b>Address: 02CCH 02CDH</b>	
Default:	0	Control mode:	All	
Unit:	-dB	Setting range:	0 to 40	
Format:	DEC	Data size:	16-bit	

## Settings:

The attenuation level of the fifth Notch filter. A value of 5 indicates -5 dB. Set this parameter to 0 to disable the fifth Notch filter.

<b>P2.103</b>	<b>Notch filter 5 - Q factor</b>		<b>Address: 02CEH 02CFH</b>	
Default:	5	Control mode:	All	
Unit:	-	Setting range:	1 to 10	
Format:	DEC	Data size:	16-bit	

## Settings:

The resonance Q factor of the fifth Notch filter. This function is disabled if P2.102 is 0. P2.101, P2.102, and P2.103 are the fifth set of Notch filter parameters.

<b>P2.104</b>	<b>Torque command condition for P/PI switching</b>		<b>Address: 02D0H 02D1H</b>	
Default:	800	Control mode:	PT / PR	
Unit:	%	Setting range:	1 to 800	
Format:	DEC	Data size:	16-bit	

## Settings:

When the Torque command exceeds P2.104, the speed controller gain is switched from PI to P in order to reduce response overshoot.

<b>P2.105</b>	<b>Automatic gain adjustment level 1</b>		<b>Address: 02D2H 02D3H</b>
Default:	11	Control mode:	All
Unit:	-	Setting range:	1 to 21
Format:	DEC	Data size:	16-bit

Settings:

Use this parameter to adjust the bandwidth when auto-tuning. The higher the value, the higher the bandwidth after auto-tuning. However, the bandwidth margin may be insufficient, causing machine jitter. The smaller the value, the lower the bandwidth after auto-tuning. However, the response is slower.

Automatic gain adjustment level 1	Stiffness and response	Applicable mechanical parts
1 - 7	Low stiffness and low response	Belt, gear rack, reducer, cam
8 -14	Medium stiffness and medium response	Screw
15 - 21	High stiffness and high response	Direct-coupled mechanical parts

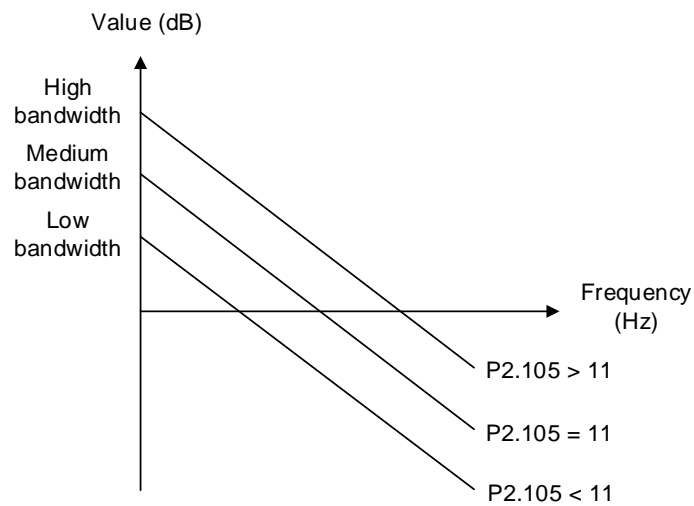

8

<b>P2.106</b>	<b>Automatic gain adjustment level 2</b>		<b>Address: 02D4H 02D5H</b>
Default:	2000	Control mode:	All
Unit:	pulse	Setting range:	1 to 50331648
Format:	DEC	Data size:	32-bit

Settings:

Use this parameter to adjust the maximum allowable overshoot when auto-tuning. The overshoot range is set according to either the user's requirement or the machine characteristics. The higher the value, the greater the maximum overshoot allowed by auto-tuning. However, the response is faster. The smaller the value, the smaller the maximum overshoot allowed by auto-tuning. However, the response is slower.

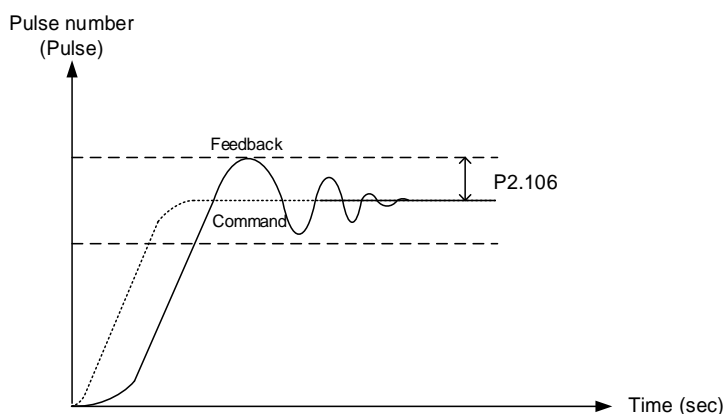

<b>P2.107</b>	<b>Rate of change for resonance suppression low-pass filter</b>		<b>Address: 02D6H 02D7H</b>
Default:	100	Control mode:	All
Unit:	%	Setting range:	0 to 100
Format:	DEC	Data size:	16-bit

Settings:

Adjusts the rate of change for **the resonance suppression low-pass filter** (P2.025) according to the gain switching condition.

(This parameter is inversely proportional to the value of P2.025. The smaller the setting value of P2.107, the stronger the filtering effect.)

<b>P2.108 - P2.111</b>	<b>Reserved</b>		
----------------------------	-----------------	--	--

<b>P2.112 ▲</b>	<b>Special bit register 4</b>		<b>Address: 02E0H 02E1H</b>	
Default:	0x2018	Control mode:	All	
Unit:	-	Setting range:	0x0000 to 0x753F	
Format:	HEX	Data size:	16-bit	

Settings:

Bit	7	6	5	4	3	2	1	0
-----	---	---	---	---	---	---	---	---

Bit	15	14	13	12	11	10	9	8
-----	----	----	----	----	----	----	---	---

Bit	Function	Description
Bit 0	Reserved	-
Bit 1	Enable AL089	0: disable AL089 1: enable AL089
Bit 2 - Bit 7	Reserved	-
Bit 8	Motor hard stop function selection	Not applicable to Torque mode. Motor hard stop 2 currently supports motors with Hall sensors (PM.003.Y = 1) or absolute motors. 0: Motor hard stop 1 (Refer to the settings of P1.057, P1.058, and P1.060.) 1: Motor hard stop 2 (Refer to the settings of P1.105, P1.106, and P1.058.)
Bit 9	Reserved	-
Bit 10	Enable AL040	This function is supported only in Speed mode. When the full-closed loop control is enabled (P1.074 = 1), the system will force enable the detection for AL040, so this function is invalid. 0: disable AL040 1: enable AL040
Bit 11, Bit 12	Reserved	-
Bit 13	Regenerative brake method	Use method 2 to release the capacitor voltage faster which reduces the load voltage of the capacitor. 0: method 1 1: method 2
Bit 14	Unit selection for internal Torque command / internal torque limit (P1.012 - P1.014)	0: 1% 1: 0.1%
Bit 15	Reserved	-



## 8

<b>P2.113</b>	<b>Bandwidth of disturbance attenuation</b>		<b>Address: 02E2H 02E3H</b>
Default:	50	Control mode:	T
Unit:	Hz	Setting range:	0 - 3000
Format:	DEC	Data size:	16-bit

## Settings:

The disturbance attenuation function is disabled when P2.114 is 0. It is recommended that you set P2.113 to the default of 50. The higher you set P2.113, the more likely the high-frequency resonance is to occur; the lower you set P2.113, the less the low-frequency vibration is suppressed.

<b>P2.114</b>	<b>Level of disturbance attenuation</b>		<b>Address: 02E4H 02E5H</b>
Default:	0	Control mode:	T
Unit:	-	Setting range:	0 - 500
Format:	DEC	Data size:	16-bit

## Settings:

The disturbance attenuation function is disabled when P2.114 is 0. Increasing this parameter can better attenuate the disturbance. However, if you set the value too high, it may cause slower response and system divergence.

<b>P2.115 - P2.120</b>	<b>Reserved</b>

<b>P2.121</b>	<b>Special bit register 6</b>		<b>Address: 02F2H 02F3H</b>
Default:	0x00000000	Control mode:	All
Unit:	-	Setting range:	0x00000000 to 0x000001FF
Format:	HEX	Data size:	32-bit

Settings:

Bit	15	14	13	12	11	10	9	8	7	6	5	4	3	2	1	0
Bit	31	30	29	28	27	26	25	24	23	22	21	20	19	18	17	16

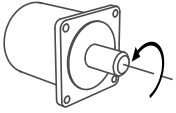
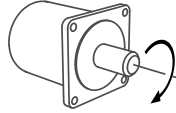
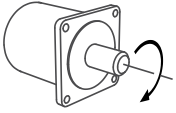
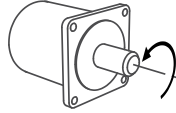
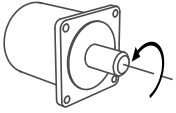
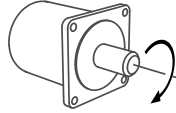
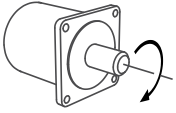
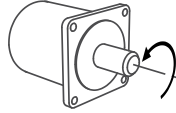
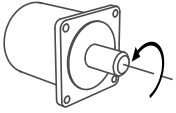
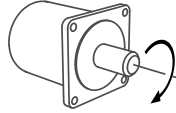
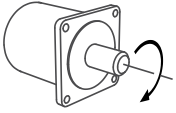
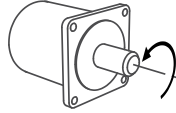
Bit	Function	Description									
Bit 0	Reserved	-									
Bit 1	Behavior after homing in communication mode	0: after homing, execute absolute positioning to the position with the offset distance set in OD 607Ch 1: decelerate to a stop after homing									
Bit 2	Definition of the settings for origin definition (P6.001) and Home offset (OD 607Ch) in communication mode	0: origin definition (P6.001) = - (setting of OD 607Ch) 1: origin definition (P6.001) = OD 607Ch									
Bit 3	Unit of Homing speeds (OD 6099h) in communication mode	0: 0.1 rpm 1: 1 rpm									
Bit 4	Reserved	-									
Bit 5	Unit selection for Homing speeds (OD 6099h), Homing acceleration (OD 609Ah), Profile acceleration (OD 6083h), and Profile deceleration (OD 6084h) in communication mode	0: the unit of OD 6099h is determined by the setting of P2.121 [Bit 3]. The unit of OD 609Ah, OD 6083h, and OD 6084h is ms (0 - 3000 rpm). <ul style="list-style-type: none"> <li>■ When P2.121 [Bit 3] = 0, the unit of OD 6099h is 0.1 rpm.</li> <li>■ When P2.121 [Bit 3] = 1, the unit of OD 6099h is 1 rpm.</li> </ul> 1: the unit of OD 6099h is PUU/sec. The unit of OD 609Ah, OD 6083h, and OD 6084h is PUU/sec <sup>2</sup> .									
Bit 6	Reserved	-									
Bit 7	Definition of positive / negative direction when P4.005 (Servo motor JOG control) controls the motor through USB / RS-485 communication	0: the same as the direction originally defined 1: in reverse to the direction originally defined Example: <table border="1" style="margin-left: 20px;"> <tr> <td>P4.005</td> <td>P1.001.Z = 0 P2.121 [Bit 7] = 0</td> <td>P1.001.Z = 0 P2.121 [Bit 7] = 1</td> </tr> <tr> <td>4999</td> <td></td> <td></td> </tr> <tr> <td>4998</td> <td></td> <td></td> </tr> </table>	P4.005	P1.001.Z = 0 P2.121 [Bit 7] = 0	P1.001.Z = 0 P2.121 [Bit 7] = 1	4999			4998		
P4.005	P1.001.Z = 0 P2.121 [Bit 7] = 0	P1.001.Z = 0 P2.121 [Bit 7] = 1									
4999											
4998											
Bit 8	Auto clearing of AL180 and AL185 after the state machine re-enters the Operational state in EtherCAT mode	0: no; manually clear the alarms 1: yes									
Bit 9 - Bit 31	Reserved	-									

<b>P2.122 - P2.124</b>	<b>Reserved</b>
------------------------	-----------------

8

P2.125	Special bit register 7		Address: 02FAH 02FBH	
Default:	0x0000	Control mode:	All	
Unit:	-	Setting range:	0x0000 to 0xFFFF	
Format:	HEX	Data size:	16-bit	

Settings:

Bit	7	6	5	4	3	2	1	0
-----	---	---	---	---	---	---	---	---

Bit	15	14	13	12	11	10	9	8
-----	----	----	----	----	----	----	---	---

Bit	Function	Description
Bit 0	Frequency setting of the filter processing the speed feedback in the monitoring variable of P0.002 = 7	0: 15 Hz 1: 1 Hz
Bit 1, Bit 2	Reserved	-
Bit 3	Bandwidth response level reversion	Before using this function, set the gain adjustment mode to mode 1, mode 2, or mode 3. When the system limit is reached and the resonance cannot be suppressed, the servo automatically reverts to the response level where the resonance does not occur. 0: on 1: off
Bit 4 - Bit 6	Reserved	-
Bit 7	Smoothing function for Velocity offset (OD 60B1h) and Torque offset (OD 60B2h) in EtherCAT communication mode	0: on 1: off
Bit 8 - Bit 10	Reserved	-
Bit 11	Detection switch for monitoring variable -213 (Delta linear scale signal strength)	The setting takes effect after power cycling of the servo drive. 0: on 1: off
Bit 12 - Bit 15	Reserved	-

P2.126	Bandwidth for speed loop response		Address: 02FCH 02FDH	
Default:	40	Control mode:	All	
Unit:	Hz	Setting range:	1 to 1000	
Format:	DEC	Data size:	16-bit	

Settings:

The setting of P2.126 is effective only when you set P2.032 to 5 or 6.

Bandwidth	Stiffness and response	Applicable mechanical parts
1 - 100 Hz	Low stiffness and low response	Belt, gear rack, reducer, cam
101 - 250 Hz	Medium stiffness and medium response	Screw
251 Hz or above	High stiffness and high response	Direct-coupled mechanical parts

Note: the servo drive automatically sets the response of the position loop according to the setting of P2.126. The function of P2.126 is the same as that of P2-31 for the A2 series models.

**P3.xxx Communication parameters**

<b>P3.000●</b>	<b>Address</b>		<b>Address: 0300H 0301H</b>
Default:	0x007F	Control mode:	All
Unit:	-	Setting range:	0x0001 - 0x007F (A3-M, A3-L, A3-F) 0x0001 - 0xFFFF (A3-E)
Format:	HEX	Data size:	16-bit

Settings:



U Z YX

YX	Communication address setting	UZ	Reserved
----	-------------------------------	----	----------

The address setting required for using RS-485, CANopen, and DMCNET communication. Make sure there are no duplicate addresses in the same communication circuit, or it may cause communication failure.

■ RS-485

When the master station sets the communication address to 0xFF, the address is always 0xFF in the response message.

■ EtherCAT

When P3.018.A = 1, the address refers to the setting of P3.000; when P3.018.A = 0, the address must be set by the controller.

<b>P3.001●</b>	<b>Transmission speed</b>		<b>Address: 0302H 0303H</b>
Default:	0x0203 (A3-M, A3-L, A3-E) 0x3203 (A3-F)	Control mode:	All
Unit:	-	Setting range:	0x0000 - 0x0405 (A3-M, A3-L, A3-E) 0x0000 - 0xF405 (A3-F)
Format:	HEX	Data size:	16-bit

Settings:



U Z Y X

X	RS-485 transmission speed	Z	CANopen / DMCNET transmission speed
Y	Reserved	U	DMCNET motion card

■ X: RS-485 transmission speed

0: 4800 bps	1: 9600 bps	2: 19200 bps
3: 38400 bps	4: 57600 bps	5: 115200 bps

■ Z: CANopen / DMCNET transmission speed\*3

0: 125 Kbps	1: 250 Kbps	2: 500 Kbps
3: 800 Kbps	4: 1.0 Mbps	-

■ U: DMCNET motion card

0: use Delta's controller, such as PLC or HMI

3: use Delta's motion card

Note:

1. If this parameter is set through CANopen, only Z can be set and the others remain unchanged.
2. The transmission speed of USB is set at 1.0 Mbit/s and cannot be changed.
3. After the Z value is set, cycle the power to take effect.

P3.002	Modbus communication protocol		Address: 0304H 0305H
Default:	0x0006	Control mode:	All
Unit:	-	Setting range:	0x0000 - 0x0008
Format:	HEX	Data size:	16-bit

Settings:

Definition of each value:

0: 7, N, 2 (Modbus, ASCII)	1: 7, E, 1 (Modbus, ASCII)	2: 7, O, 1 (Modbus, ASCII)
3: 8, N, 2 (Modbus, ASCII)	4: 8, E, 1 (Modbus, ASCII)	5: 8, O, 1 (Modbus, ASCII)
6: 8, N, 2 (Modbus, RTU)	7: 8, E, 1 (Modbus, RTU)	8: 8, O, 1 (Modbus, RTU)

P3.003	Modbus communication error handling		Address: 0306H 0307H
Default:	0x0000	Control mode:	All
Unit:	-	Setting range:	0x0000 - 0x0001
Format:	HEX	Data size:	16-bit

Settings:

0: display AL020 and let motor continue operating.

1: display AL020 and let motor decelerate to a stop. Deceleration time is set in P5.003.B.

P3.004	Modbus communication timeout		Address: 0308H 0309H
Default:	0	Control mode:	All
Unit:	sec	Setting range:	0 to 20
Format:	DEC	Data size:	16-bit

Settings:

If the value is not 0, communication timeout is enabled immediately. To disable this function, set the value to 0.

<b>P3.005</b>	<b>Modbus communication</b>		<b>Address: 030AH 030BH</b>
Default:	0x0000	Control mode:	All
Unit:	-	Setting range:	0x0000 - 0x0112
Format:	HEX	Data size:	16-bit

Settings:



X	Reserved	Z	During Modbus communication, when the function code is 03H or 10H (read or write multiple words), the system gives priority to read or write high-byte data.
Y	Sets the servo drive as the master or slave of Modbus	U	Reserved

- Y: sets the servo drive as the master or slave of Modbus.
  - 0: slave of Modbus
  - 1: master of Modbus
- Z: during Modbus communication, when the function code is 03H or 10H (read or write multiple words), the system gives priority to read or write high-byte data. Use this function for controllers with different priority for transmitting high byte and low byte of the packets.
  - 0: transmit low byte first
  - 1: transmit high byte first

<b>P3.006</b>	<b>Digital input (DI) control switch</b>		<b>Address: 030CH 030DH</b>
Default:	0x0000	Control mode:	All
Unit:	-	Setting range:	0x0000 - 0x1FFF
Format:	HEX	Data size:	16-bit

Settings:

Control switch for the source of DI. Each bit of this parameter determines the input source of one DI signal: Bit 0 - Bit 12 correspond to DI1 - DI13.

The setting for each bit is as follows:

- 0: DI status is controlled by the external terminal block.
- 1: DI status is controlled by P4.007.

For more information on DI functional planning, please see:

DI1 - DI8: P2.010 - P2.017

DI9 - DI13: P2.036 - P2.040



<b>P3.007</b>	<b>Modbus communication response delay time</b>		<b>Address: 030EH 030FH</b>
Default:	1	Control mode:	All
Unit:	0.5 ms	Setting range:	0 to 1000
Format:	DEC	Data size:	16-bit

Settings:

Delays the time of communication response from servo drive to controller.

<b>P3.008</b>	<b>Reserved</b>
---------------	-----------------

<b>P3.009</b>	<b>Communication synchronization</b>		<b>Address: 0312H 0313H</b>
Default:	0x5055	Control mode:	CANopen / EtherCAT
Unit:	-	Setting range:	Shown as follows
Format:	HEX	Data size:	16-bit

Settings:

The synchronous setting is divided into U, Z, Y, and X (hexadecimal):

Digit	U	Z	Y	X
Function	Range of synchronous error (CANopen)	Target value (EtherCAT)	Deadband (CANopen)	Reserved
Range	1 to 9	M, F, L: 0 to F E: 0 to A	0 to F	-

The slave synchronizes with the master via SYNC. The definition is as follows:

- Y: sets the size of deadband (unit:  $\mu\text{sec}$ ). If the deviation between the SYNC arrival time and the target value does not exceed the deadband, a correction is not needed.
- Z: when the servo is operating in the DC-Synchronous mode, you can adjust the timing of the servo accessing EtherCAT packets to ensure that this timing is not in conflict with the timing of the controller sending the packets. The delay time in the following figure is  $(T/10) \times Z$  ( $\mu\text{s}$ ).

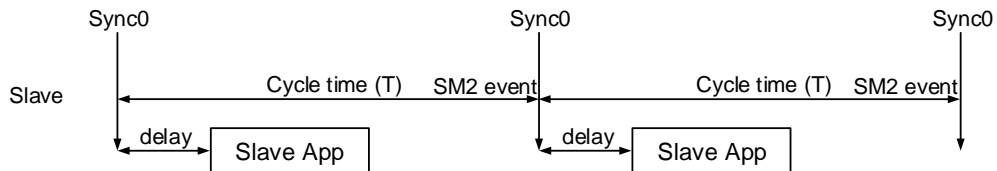

- U: if the deviation between the SYNC arrival time and the target value is smaller than the range, it means the synchronization is successful (unit:  $10 \mu\text{s}$ ).

<b>P3.010</b>	<b>CANopen / DMCNET protocol</b>		<b>Address: 0314H 0315H</b>
Default:	0x1011	Control mode:	CANopen / DMCNET
Unit:	-	Setting range:	0x0000 - 0xFFFF
Format:	HEX	Data size:	16-bit

Settings:

X	Reserved	Z	Source of torque limit
Y	Motor status when communication error occurs	U	Auto clearing of PDO alarm

- Y: motor status when the communication error occurs
  - 0: when the communication error occurs (AL170), the motor continues operating (only applicable to DMCNET mode and CANopen B mode).
  - 1: when the communication error occurs (AL180), the motor is switched to Servo Off state (only applicable to CANopen C mode).
- Z: source of torque limit (only functions in DMCNET mode)
  - 0: communication commands.
  - 1: DI commands.
- U: auto clearing of PDO alarm
  - 0: when the PDO is in error (AL112, AL113, AL121 - AL132), the alarm has to be cleared by DI.ARST, NMT reset, or OD 6040h [Bit 7] Fault reset.
  - 1: if the PDO error (AL112, AL113, AL121 - AL132) disappears, the servo alarm is automatically cleared.

<b>P3.011</b>	<b>CANopen / DMCNET options</b>		<b>Address: 0316H 0317H</b>
Default:	0x0000	Control mode:	CANopen / DMCNET
Unit:	-	Setting range:	Shown as follows
Format:	HEX	Data size:	16-bit

Settings:



X	Store parameters in EEPROM or not	Z	Reserved
Y	Reserved	U	Reserved

- X: store parameters in EEPROM or not
  - 0: not to store parameters in EEPROM.
  - 1: when writing through CANopen / DMCNET packets (PDOs), store parameters in EEPROM.

Note: if you set X to 1 and continuously write parameters through DMCNET PDOs, it shortens the lifetime of the EEPROM.



8

<b>P3.012</b>	<b>Communication support setting</b>		<b>Address: 0318H 0319H</b>
Default:	0x0000	Control mode:	CANopen / DMCNET / EtherCAT
Unit:	-	Setting range:	0x0000 - 0x1111
Format:	HEX	Data size:	16-bit

Settings:



X	Reserved	Z	Load in CANopen / DMCNET / EtherCAT parameter values
Y	Reserved	U	Error clearing when the limit alarm occurs

- Z:** load in CANopen / DMCNET / EtherCAT parameter values
  - 0: when the servo drive is power cycled or the communication is reset, parameters in the following table load the values of the CANopen / DMCNET / EtherCAT parameters.
  - 1: when the servo drive is power cycled or the communication is reset, parameters in the following table retain the same settings and do not load the values of the CANopen / DMCNET / EtherCAT parameters.

Relevant parameters for Z setting:

Parameter	P3.012 = 0x0100 (Z = 1)		P3.012 = 0x0000 (Z = 0)	
	Servo parameter	Default	OD address	Default
Motor stop mode	P1.032	0x0000	605Bh	0
S-curve acceleration constant	P1.034	200	6087h	200
Zero speed range	P1.038	100 (rotary*: 0.1 rpm; linear*: 0.1 mm/s)	606Fh	100 (0.1 rpm)
E-Gear ratio - numerator N1	P1.044	16777216	6093h sub1	1
E-Gear ratio - denominator M	P1.045	100000	6093h sub2	1
Speed reached (DO.SP_OK) range	P1.047	10 (rotary: 1 rpm; linear: 1 mm/s)	606Dh	100 (0.1 rpm)
Accumulated time to reach desired speed	P1.049	0	606Eh	0
Maximum speed limit	P1.055	Depending on the motor (rotary: 1 rpm; linear: 1 mm/s)	607Fh	Depending on the motor (0.1 rpm)
			6080h	Depending on the motor (rpm)
Excessive deviation warning condition of Position command	P2.035 (pulse)	50331648	6065h	50331648
Positive software limit (PP/CSP/CSV/CST mode)	P5.008	2147483647	607Dh sub2	2147483647
Negative software limit (PP/CSP/CSV/CST mode)	P5.009	-2147483648	607Dh sub1	-2147483648
Origin definition (HM mode)	P6.001	0	607Ch	0

Methods to write parameters to EEPROM (non-volatile):

SDO: parameters are stored in EEPROM when written.

PDO: refer to the setting of P3.011.X. (X = 1: when written through PDOs, parameters are stored in EEPROM; X = 0: when written through PDOs, parameters are not stored in EEPROM.)

Note:

1. When the function of OD 1010h (Store parameters) is enabled, the CANopen OD value is stored in non-volatile memory. When P3.012.Z = 0, the non-volatile value of CANopen OD is loaded as the initial content. Refer to the descriptions in CANopen Standard. When P3.012.Z = 1, the initial content refers to the preceding table.
  2. Rotary means a permanent-magnet synchronous rotary motor; linear means a permanent-magnet synchronous linear motor.
- U: error clearing when the limit alarm occurs
    - 0: when the limit alarm (AL014 or AL015) occurs, it needs to be cleared before the servo reverses to move away from the limit.
    - 1: when the limit alarm (AL014 or AL015) occurs, it does not need to be cleared before the servo reverses to move away from the limit.

Note: determine whether the servo has reached the limit with the bit status of OD 6041h Statusword and OD 60FDh Digital inputs.

Positive limit: OD 6041h [Bit 14] is On & OD 60FDh [Bit 1] is On

Negative limit: OD 6041h [Bit 15] is On & OD 60FDh [Bit 0] is On

The status of other bits of OD 6041h (Fault / Warning / Quick stop) remains unchanged when the servo reaches the limit.

P3.013	Controller's full-closed loop feedback source		Address: 031AH 031BH
Default:	0x0000	Control mode:	PR* (full-closed loop)
Unit:	-	Setting range:	0x0000 - 0x0022
Format:	HEX	Data size:	16-bit

Settings:



X	Encoder feedback source in full-closed loop control	Y	Z phase offset source in full-closed loop mode
Z	Reserved	U	Reserved

- X: encoder feedback source in full-closed loop control (the source displayed in the Feedback position [PUU])
  - 0: motor encoder feedback
  - 1: auxiliary encoder feedback
  - 2: in semi-closed loop control, it is the motor encoder feedback; in full-closed loop control, it is the auxiliary encoder feedback.

8

- Y: Z phase offset source in full-closed loop mode
  - 0: motor
  - 1: auxiliary encoder
  - 2: in semi-closed loop control, it is the motor's Z phase offset; in full-closed loop control, it is the auxiliary encoder's Z phase offset.

Note:

1. This parameter setting is different from P1.074.Y (switch between motor encoder and auxiliary encoder). This parameter only modifies the feedback signal source uploaded to the controller. It is suggested that you set P3.013 to 0x0022 to avoid misoperation when the motor is in the Servo On state.
2. PR full-closed loop function is not yet supported.

<b>P3.014 - P3.016</b>	<b>Reserved</b>
------------------------	-----------------

<b>P3.017</b>	<b>CANopen B mode disconnection delay time</b>	<b>Address: 0322H 0323H</b>	
Default:	1000	Control mode:	CANopen
Unit:	ms	Setting range:	1 to 1000
Format:	DEC	Data size:	16-bit

Settings:

If the communication disconnection time exceeds this set value when in the PV (Profile Velocity), PT (Profile Torque), or HM (Homing Mode) mode of CANopen B mode, the system issues AL303.

<b>P3.018</b>	<b>EtherCAT special function switch</b>	<b>Address: 0324H 0325H</b>	
Default:	0x00002000	Control mode:	EtherCAT
Unit:	-	Setting range:	0x00000000 - 0x01112211
Format:	HEX	Data size:	32-bit

Settings:

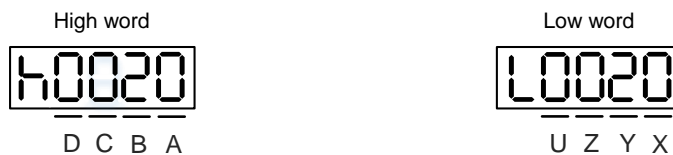

A	Source setting for the content loaded to the EtherCAT Station Alias Register 0x0012 after the servo drive is powered on	X	Unit selection for Target velocity (OD 60FFh) and Velocity actual value (OD 606Ch) when in the PV (Profile Velocity) mode or CSV (Cyclic Synchronous Velocity) mode
B	Reserved	Y	Reserved
C	Unit selection for the maximum speed of OD 607Fh and OD 6080h	Z	AL185 communication disconnection detection setting
D	Reserved	U	Reserved

- A: source setting for the content loaded to the EtherCAT Station Alias Register 0x0012 after the servo drive is powered on.
  - 0: determined by the EtherCAT EEPROM station number field (ADR 0x0004) setting, which needs to be set via the controller interface.
  - 1: determined by the station number set with servo parameter P3.000.
- X: unit selection for Target velocity (OD 60FFh) and Velocity actual value (OD 606Ch) when in the PV (Profile Velocity) mode or CSV (Cyclic Synchronous Velocity) mode.
  - 0: 0.1 rpm
  - 1: pulse/sec
- Z: AL185 communication disconnection detection setting
  - 0: disconnection detection starts after EtherCAT communication enters OP state.
  - 1: disconnection detection starts after EtherCAT communication enters Init state.
  - 2: disable disconnection detection.

Note: when using the ring topology connection, set P3.018.Z to 2 to disable the disconnection detection.
- C: unit selection for the maximum speed of OD 607Fh and OD 6080h
  - 0: 0.1 rpm for OD 607Fh and rpm for OD 6080h.
  - 1: pulse/sec for OD 607Fh and OD 6080h.

<b>P3.019</b>	<b>Statusword display content</b>		<b>Address: 0326H 0327H</b>	
Default:	0x00000021	Control mode:	CANopen / EtherCAT	
Unit:	-	Setting range:	0x00000000 - 0x0000FFFF	
Format:	HEX	Data size:	32-bit	

Settings:



A	Reserved	X	Reserved
B	Reserved	Y	Reserved
C	Reserved	Z	Display content of OD 6041h [Bit 14]
D	Reserved	U	Reserved

- Z: display content of OD 6041h [Bit 14]
  - 0: display the positive limit status.
  - 1: display the current synchronization status between the servo drive and controller. When the status displays On, it indicates that the synchronization is complete (SYNC\_OK).

<b>P3.020 - P3.021</b>	<b>Reserved</b>
----------------------------	-----------------

## 8

<b>P3.022</b>	<b>EtherCAT PDO timeout setting</b>		<b>Address: 032CH 032DH</b>
Default:	0xFF04	Control mode:	EtherCAT
Unit:	-	Setting range:	0x0002 - 0xFF14
Format:	HEX	Data size:	16-bit

Settings:

When using the PDO to transmit data periodically, use this parameter to set the timeout setting. The following two sets of digits specify the trigger conditions for AL180 and AL3E3 respectively to ensure that the servo drive receives the PDO. When one of the alarm occurs, it means the allowable duration for packet loss exceeds the set range.



Digit	UZ	YX
Function	AL180 trigger condition	AL3E3 trigger condition
Range	0x00 (disabled) - 0xFF (default)	0x02 to 0x14

- YX: AL3E3 trigger condition (allowable cycle for elapsed time); applicable to CSP / CSV / CST mode.

AL3E3 occurs when the servo drive does not receive the PDO within the set cycle.

When the communication cycle is 4 ms and you set this parameter to 0x02 (allow two cycles), it means if the servo drive does not receive any PDO within 8 ms, AL3E3 occurs.

- UZ: AL180 trigger condition (allowable duration for elapsed time); applicable to all operation modes.

AL180 occurs when the servo drive does not receive the PDO within the set duration (unit: ms).

For example, when you set P3.022.UZ to 0x01, the duration is 1 ms; when you set P3.022.UZ to 0x02, the duration is 2 ms; and when you set P3.022.UZ to 0xFF, the duration is 255 ms.

<b>P3.023 - P3.038</b>	<b>Reserved</b>
----------------------------	-----------------

## P4.xxx Diagnosis parameters

P4.000	Fault record (last)		Address: 0400H 0401H
Default:	0x00000000	Control mode:	All
Unit:	-	Setting range:	-
Format:	HEX	Data size:	32-bit

Settings:

The last abnormal status record.

Low word (LXXXX): the alarm number.

High word (hYYYY): the error code corresponding to CANopen / DMCNET / EtherCAT. For example, when the low word displays ALF21, the high word displays the error code of ALF21.

P4.001★	Fault record (second to the last)		Address: 0402H 0403H
Default:	0x00000000	Control mode:	All
Unit:	-	Setting range:	-
Format:	HEX	Data size:	32-bit

Settings:

The second to last abnormal status record.

Low word (LXXXX): the alarm number.

High word (hYYYY): the error code corresponding to CANopen / DMCNET / EtherCAT. For example, when the low word displays ALF21, the high word displays the error code of ALF21.

P4.002★	Fault record (third to the last)		Address: 0404H 0405H
Default:	0x00000000	Control mode:	All
Unit:	-	Setting range:	-
Format:	HEX	Data size:	32-bit

Settings:

The third to last abnormal status record.

Low word (LXXXX): the alarm number.

High word (hYYYY): the error code corresponding to CANopen / DMCNET / EtherCAT. For example, when the low word displays ALF21, the high word displays the error code of ALF21.

## 8

<b>P4.003★</b>	<b>Fault record (fourth to the last)</b>		<b>Address: 0406H 0407H</b>	
Default:	0x00000000	Control mode:	All	
Unit:	-	Setting range:	-	
Format:	HEX	Data size:	32-bit	

Settings:

The fourth to last abnormal status record.

Low word (LXXXX): the alarm number.

High word (hYYYY): the error code corresponding to CANopen / DMCNET / EtherCAT. For example, when the low word displays ALF21, the high word displays the error code of ALF21.

<b>P4.004★</b>	<b>Fault record (fifth to the last)</b>		<b>Address: 0408H 0409H</b>	
Default:	0x00000000	Control mode:	All	
Unit:	-	Setting range:	-	
Format:	HEX	Data size:	32-bit	

Settings:

The fifth to last abnormal status record.

Low word (LXXXX): the alarm number.

High word (hYYYY): the error code corresponding to CANopen / DMCNET / EtherCAT. For example, when the low word displays ALF21, the high word displays the error code of ALF21.

<b>P4.005</b>	<b>Servo motor JOG control</b>		<b>Address: 040AH 040BH</b>	
Default:	20	Control mode:	All	
Unit:	1 rpm (rotary)* 0.01 mm/s (linear)*	Setting range:	0 to 5000 (rotary)* 0 to 50000 (linear)*	
Format:	DEC	Data size:	16-bit	

Settings:

The control methods are as follows:

1. Panel control:

Set the JOG speed to P4.005 with the panel and it displays the JOG symbol. Pressing the UP key controls the JOG operation in the positive direction; pressing the DOWN key controls the JOG operation in the negative direction. Stop pressing to stop the JOG operation. If any alarm occurs during the operation, then the motor does not move.

2. DI control:

If you set the DI to 0x37 (JOGU) and 0x38 (JOGD) (refer to Table 8.1), then the JOG operation in the positive or negative direction is controlled with this DI.

3. USB / RS-485 communication control:

Set the JOG speed (1 - 4997, 5000) for operation to P4.005, and then set P4.005 to 4999 or 4998 for positive or negative direction. To stop the motor operation, set P4.005 to 0.

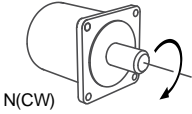
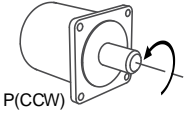
0: stop operation 4998*2: JOG operation in negative direction	1 - 4997, 5000: JOG speed 4999*2: JOG operation in positive direction
	

Note:

1. When using communication to write values frequently,, set P2.030 to 5.
2. When you control the JOG operation with the panel, the operation direction (positive / negative) varies depending on the value of P1.001.Z. When you control the JOG speed with USB / RS-485 communication, the operation direction (positive / negative) can be modified with P2.121 [Bit 7].
3. Rotary means a permanent-magnet synchronous rotary motor; linear means a permanent-magnet synchronous linear motor.
4. When P1.001.X = B, C or P1.001.Y = 1, JOG operation test is not supported.

P4.006■	Software digital output register (readable and writable)		Address: 040CH 040DH
Default:	0x0000	Control mode:	All
Unit:	-	Setting range:	0x0000 - 0xFFFF
Format:	HEX	Data size:	16-bit

Settings:

bit 00: corresponds to DO code = 0x30	bit 08: corresponds to DO code = 0x38
bit 01: corresponds to DO code = 0x31	bit 09: corresponds to DO code = 0x39
bit 02: corresponds to DO code = 0x32	bit 10: corresponds to DO code = 0x3A
bit 03: corresponds to DO code = 0x33	bit 11: corresponds to DO code = 0x3B
bit 04: corresponds to DO code = 0x34	bit 12: corresponds to DO code = 0x3C
bit 05: corresponds to DO code = 0x35	bit 13: corresponds to DO code = 0x3D
bit 06: corresponds to DO code = 0x36	bit 14: corresponds to DO code = 0x3E
bit 07: corresponds to DO code = 0x37	bit 15: corresponds to DO code = 0x3F

If you set P2.018 to 0x0130, then the output of DO1 is the bit 00 status of P4.006, and so forth. Set the DO codes (0x30 - 0x3F) through communication DO, and then write to P4.006.



<b>P4.007■</b>	<b>Multi-function for digital input</b>		<b>Address: 040EH 040FH</b>	
Default:	0x0000	Control mode:	All	
Unit:	-	Setting range:	0x0000 - 0x3FFF	
Format:	HEX	Data size:	16-bit	

Settings:

The source of the DI input signal can be the external hardware terminal or the internal software DI (P4.007), which is determined by P3.006. If the corresponding bit of P3.006 is 1, it means the source is the software DI (P4.007); if the corresponding bit is 0, then the source is the hardware DI. See the following figure:

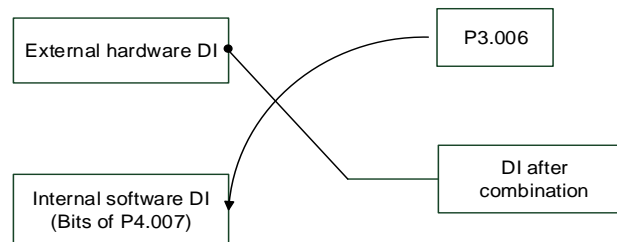

Read parameter: shows the DI status after combining external DI and software DI.

Write parameter: writes the software DI status. This function is the same whether you use the panel or communication to set the parameter.

For example: if the read value of P4.007 is 0x0011, it means DI1 and DI5 are on after combination; if the value written to P4.007 is 0x0011, it means the software DI1 and DI5 are on. Refer to P2.010 - P2.014 for more information on DI1 - DI5 functional planning.

<b>P4.008★</b>	<b>Input status of servo drive panel (read-only)</b>		<b>Address: 0410H 0411H</b>	
Default:	-	Control mode:	All	
Unit:	-	Setting range:	Read-only	
Format:	HEX	Data size:	16-bit	

Settings:

Read this parameter through communication and check if the five keys (MODE, UP, DOWN, SHIFT, and SET) can function normally.

<b>P4.009★</b>	<b>Digital output status (read-only)</b>		<b>Address: 0412H 0413H</b>	
Default:	-	Control mode:	All	
Unit:	-	Setting range:	0x0000 - 0x001F	
Format:	HEX	Data size:	16-bit	

Settings:

There is no difference either reading by panel or through communication.

<b>P4.010 ▲ ■</b>	<b>Hardware calibration options</b>		<b>Address: 0414H 0415H</b>	
Default:	0	Control mode:	All	
Unit:	-	Setting range:	0 to 14	
Format:	DEC	Data size:	16-bit	

Settings:

0: reserved	4: calibrate the offset of the current detector (W phase)
1: calibrate the offset of the analog speed input hardware	5: calibrate the offset of options 1 - 4
2: calibrate the offset of the analog torque input hardware	6 - 14: reserved
3: calibrate the offset of the current detector (V phase)	-

Note: the calibration function must be enabled by setting P2.008. When calibration, remove all external wirings for torque input and make sure the servo is in the Servo Off state.

<b>P4.011</b>	<b>Analog speed input 1 - hardware offset calibration</b>		<b>Address: 0416H 0417H</b>	
Default:	Factory setting	Control mode:	All	
Unit:	-	Setting range:	13926 to 18842	
Format:	DEC	Data size:	16-bit	

Settings:

Manually calibrate the hardware offset. The function must be enabled by setting P2.008. Do not change the auxiliary calibration as this parameter cannot be reset.

<b>P4.012</b>	<b>Analog speed input 2 - hardware offset calibration</b>		<b>Address: 0418H 0419H</b>	
Default:	Factory setting	Control mode:	All	
Unit:	-	Setting range:	13926 to 18842	
Format:	DEC	Data size:	16-bit	

Settings:

Manually calibrate the hardware offset. The function must be enabled by setting P2.008. Do not change the auxiliary calibration as this parameter cannot be reset.

<b>P4.013</b>	<b>Analog torque input 1 - hardware offset calibration</b>		<b>Address: 041AH 041BH</b>	
Default:	Factory setting	Control mode:	All	
Unit:	-	Setting range:	13926 to 18842	
Format:	DEC	Data size:	16-bit	

Settings:

Manually calibrate the hardware offset. The function must be enabled by setting P2.008. Do not change the auxiliary calibration as this parameter cannot be reset.

8

<b>P4.014</b>	<b>Analog torque input 2 - hardware offset calibration</b>		<b>Address: 041CH 041DH</b>
Default:	Factory setting	Control mode:	All
Unit:	-	Setting range:	13926 to 18842
Format:	DEC	Data size:	16-bit

Settings:

Manually calibrate the hardware offset. The function must be enabled by setting P2.008. Do not change the auxiliary calibration as this parameter cannot be reset.

<b>P4.015</b>	<b>Current detector (V1 phase) - hardware offset calibration</b>		<b>Address: 041EH 041FH</b>
Default:	Factory setting	Control mode:	All
Unit:	-	Setting range:	13926 to 18842
Format:	DEC	Data size:	16-bit

Settings:

Manually calibrate the hardware offset. The function must be enabled by setting P2.008. Do not change the auxiliary calibration as this parameter cannot be reset.

<b>P4.016</b>	<b>Current detector (V2 phase) - hardware offset calibration</b>		<b>Address: 0420H 0421H</b>
Default:	Factory setting	Control mode:	All
Unit:	-	Setting range:	13926 to 18842
Format:	DEC	Data size:	16-bit

Settings:

Manually calibrate the hardware offset. The function must be enabled by setting P2.008. Do not change the auxiliary calibration as this parameter cannot be reset.

<b>P4.017</b>	<b>Current detector (W1 phase) - hardware offset calibration</b>		<b>Address: 0422H 0423H</b>
Default:	Factory setting	Control mode:	All
Unit:	-	Setting range:	13926 to 18842
Format:	DEC	Data size:	16-bit

Settings:

Manually calibrate the hardware offset. The function must be enabled by setting P2.008. Do not change the auxiliary calibration as this parameter cannot be reset.

<b>P4.018</b>	<b>Current detector (W2 phase) - hardware offset calibration</b>		<b>Address: 0424H 0425H</b>
Default:	Factory setting	Control mode:	All
Unit:	-	Setting range:	13926 to 18842
Format:	DEC	Data size:	16-bit

Settings:

Manually calibrate the hardware offset. The function must be enabled by setting P2.008. Do not change the auxiliary calibration as this parameter cannot be reset.

<b>P4.019</b>	<b>IGBT NTC calibration level (cannot reset)</b>		<b>Address: 0426H 0427H</b>
Default:	Factory setting	Control mode:	All
Unit:	-	Setting range:	1 to 4
Format:	DEC	Data size:	16-bit

Settings:

Cool down the drive to 25°C (77°F) before calibration. The function must be enabled by setting P2.008.

<b>P4.020</b>	<b>Analog monitor output (Ch1) - offset compensation value</b>		<b>Address: 0428H 0429H</b>
Default:	0	Control mode:	All
Unit:	mV	Setting range:	-800 to +800
Format:	DEC	Data size:	16-bit

Settings:

Manually adjust the compensation value for the offset (cannot reset). The function must be enabled by setting P2.008.

<b>P4.021</b>	<b>Analog monitor output (Ch2) - offset compensation value</b>		<b>Address: 042AH 042BH</b>
Default:	0	Control mode:	All
Unit:	mV	Setting range:	-800 to +800
Format:	DEC	Data size:	16-bit

Settings:

Manually adjust the compensation value for the offset (cannot reset). The function must be enabled by setting P2.008.

8

<b>P4.022</b>	<b>Analog speed input - offset compensation value</b>		<b>Address: 042CH 042DH</b>	
Default:	0	Control mode:	S	
Unit:	mV	Setting range:	-5000 to +5000	
Format:	DEC	Data size:	16-bit	

Settings:

Manually adjust the compensation value for the offset.

<b>P4.023</b>	<b>Analog torque input - offset compensation value</b>		<b>Address: 042EH 042FH</b>	
Default:	0	Control mode:	T	
Unit:	mV	Setting range:	-5000 to +5000	
Format:	DEC	Data size:	16-bit	

Settings:

Manually adjust the compensation value for the offset.

<b>P4.024</b>	<b>Level of undervoltage error</b>		<b>Address: 0430H 0431H</b>	
Default:	160 (220V models) 282 (400V models)	Control mode:	All	
Unit:	V (rms)	Setting range:	140 to 380	
Format:	DEC	Data size:	16-bit	

Settings:

When the voltage of the DC Bus is lower than  $P4.024 \times \sqrt{2}$ , the undervoltage alarm (AL003) occurs.

<b>P4.025 - P4.026</b>	<b>Reserved</b>			
----------------------------	-----------------	--	--	--

<b>P4.027</b>	<b>AL503 diagnosis time (220V models)</b>		<b>Address: 0436H 0437H</b>	
Default:	200	Control mode:	All	
Unit:	ms	Setting range:	1 to 500	
Format:	DEC	Data size:	16-bit	

Settings:

This parameter is used to adjust the time duration before the STO internal circuit diagnosis is performed to avoid misdetection and triggering AL503.

<b>P4.028 - P4.043</b>	<b>Reserved</b>			
----------------------------	-----------------	--	--	--

<b>P4.044</b>	<b>Special bit register 5</b>		<b>Address: 0458H 0459H</b>
Default:	0x0000	Control mode:	All
Unit:	-	Setting range:	0x0000 - 0x0003
Format:	HEX	Data size:	16-bit

Settings:



X	Single-direction torque limit setting	Z	Reserved
Y	Reserved	U	Reserved

X: this parameter limits the torque of the motor. The area with the background color is the torque limit area.

P4.044 is applicable to external analog commands and internal torque limits (P1.012 - P1.014). The following diagrams are illustrated based on P1.012 and you can set P4.044 according to the requirements.

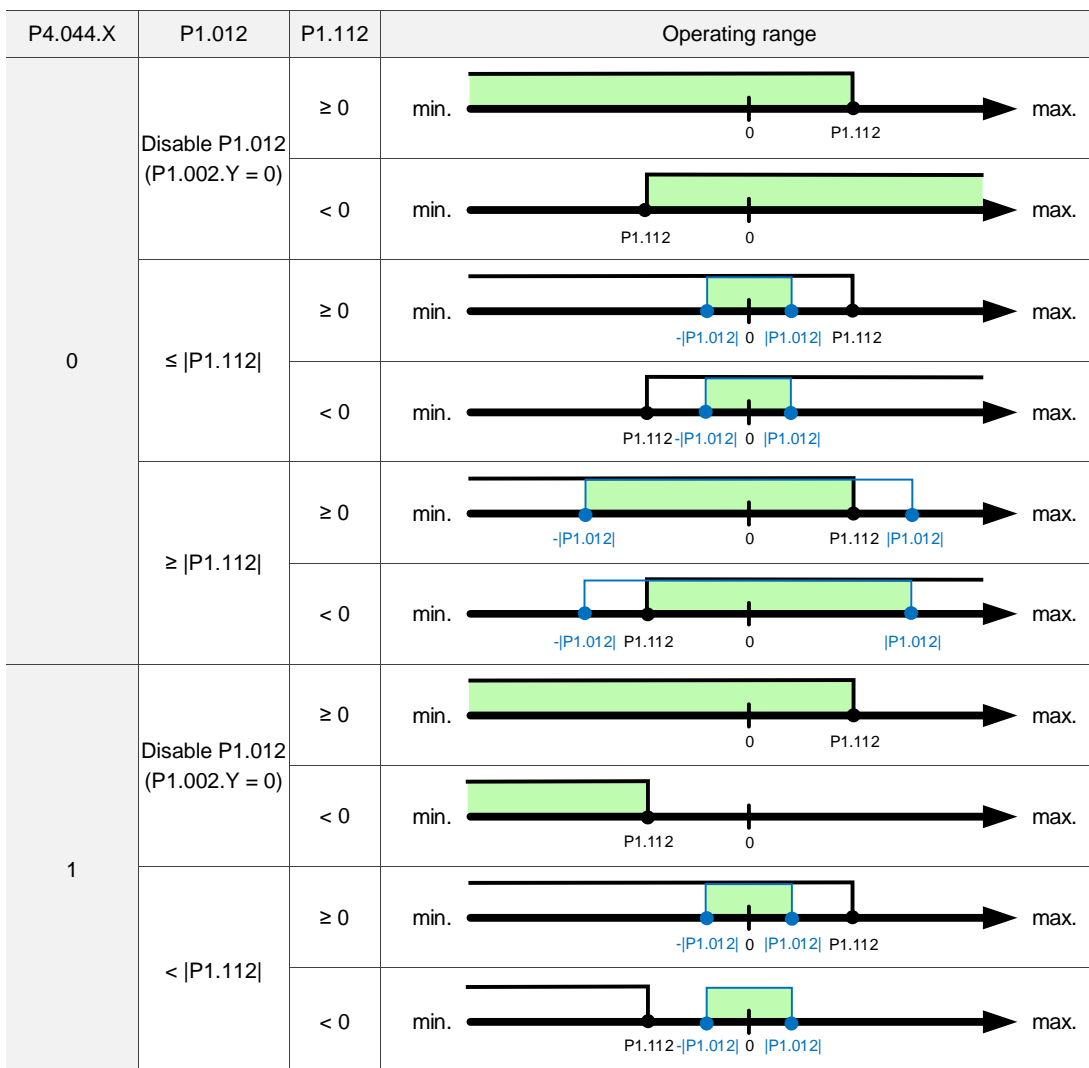

8

P4.044.X	P1.012	P1.112	Operating range
	$>  P1.112 $	$\geq 0$	
		$< 0$	
2	Disable P1.012 (P1.002.Y = 0)	$\geq 0$	
		$< 0$	
	$<  P1.112 $	$\geq 0$	
		$< 0$	
	$>  P1.112 $	$\geq 0$	
		$< 0$	
3	Disable P1.012 (P1.002.Y = 0)	$\geq 0$	
		$< 0$	
	$<  P1.112 $	$\geq 0$	
		$< 0$	
	$>  P1.112 $	$\geq 0$	
		$< 0$	

**P5.xxx Motion control parameters**

<b>P5.000★■</b>	<b>Firmware subversion</b>	<b>Address: 0500H 0501H</b>	
Default:	Factory setting	Control mode:	All
Unit:	-	Setting range:	-
Format:	DEC	Data size:	32-bit

Settings:

The low word is the subversion of the firmware.

<b>P5.001 - P5.002</b>	<b>Reserved</b>
----------------------------	-----------------

<b>P5.003</b>	<b>Deceleration time for auto-protection</b>	<b>Address: 0506H 0507H</b>	
Default:	0xEEEEFEFF	Control mode:	Except PT
Unit:	-	Setting range:	0x00000000 - 0xFFFFFFFF
Format:	HEX	Data size:	32-bit

Settings:

The parameter setting is divided into D, C, B, A, W, Z, Y, and X (hexadecimal), and the corresponding functions are as follows:

Digit	D	C	B	A	W	Z	Y	X
Function	STP	PFQS	CTO	OVF	SNL	SPL	NL	PL
Range	0 - F	0 - F	0 - F	0 - F	0 - F	0 - F	0 - F	0 - F

1. OVL (DO: 0x12, position command / feedback overflows), CTO (AL020 Serial communication timeout), SPL, SNL, PL, and NL are auto-protection functions.
2. STP is the stop function.
3. Use 0 - F to index the deceleration time of P5.020 - P5.035. For example: if you set the digit X to A, then the deceleration time of PL is determined by P5.030.





<b>P5.004</b>	<b>Homing methods</b>		<b>Address: 0508H 0509H</b>
Default:	0x0000	Control mode:	PR
Unit:	-	Setting range:	0x0000 - 0x012A
Format:	HEX	Data size:	16-bit

Settings:



X	Homing method	Z	Limit setting
Y	Z pulse setting	U	Reserved

Definition of each setting value:

U	Z	Y	X
Reserved	Limit setting	Z pulse setting	Homing method
	0 to 1	0 to 2	0 to A
	-	Y = 0: reverse to Z pulse Y = 1: go forward to Z pulse Y = 2: do not look for Z pulse	X = 0: homing in forward direction and define the positive limit as the homing origin X = 1: homing in reverse direction and define the negative limit as the homing origin X = 2: homing in forward direction, ORG: OFF→ON as the homing origin X = 3: homing in reverse direction, ORG: OFF→ON as the homing origin
-	When reaching the limit: Z = 0: show error Z = 1: reverse direction	-	X = 4: look for Z pulse in forward direction and define it as the homing origin X = 5: look for Z pulse in reverse direction and define it as the homing origin X = 6: homing in forward direction, ORG: ON→OFF as the homing origin X = 7: homing in reverse direction, ORG: ON→OFF as the homing origin
	-	-	X = 8: define the current position as the origin
	When reaching the limit: Z = 0: show error Z = 1: reverse direction	Y = 0: reverse to Z pulse Y = 1: go forward to Z pulse Y = 2: do not look for Z pulse	X = 9: torque homing in forward direction X = A: torque homing in reverse direction

P5.005	High speed homing (first speed setting)			Address: 050AH 050BH
Operation interface:	Panel / software	Communication	Control mode:	PR (set with P5.004)
Default:	100.0 (rotary)* 1000 (linear)*	1000	Data size:	32-bit
Unit:	1 rpm (rotary)* 1 μm/s (linear)*	0.1 rpm (rotary)* 1 μm/s (linear)*		
Setting range:	0.1 to 2000.0 (rotary)* 1 to 15999999 (linear)*	1 to 20000 (rotary)* 1 to 15999999 (linear)*		
Format:	DEC	DEC	-	-
Example:	1.5 = 1.5 rpm 15 = 15 μm/s	15 = 1.5 rpm 15 = 15 μm/s	-	-

Settings:

The first speed setting for high speed homing.

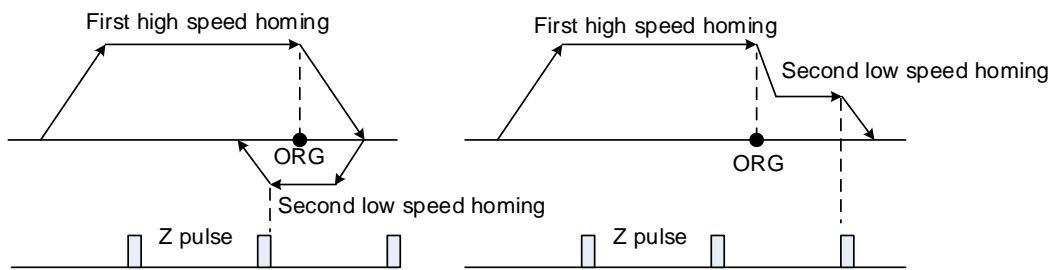

Note: rotary means a permanent-magnet synchronous rotary motor; linear means a permanent-magnet synchronous linear motor.

P5.006	Low speed homing (second speed setting)			Address: 050CH 050DH
Operation interface:	Panel / software	Communication	Control mode:	PR (set with P5.004)
Default:	20.0 (rotary)* 200 (linear)*	200	Data size:	32-bit
Unit:	1 rpm (rotary)* 1 μm/s (linear)*	0.1 rpm (rotary)* 1 μm/s (linear)*		
Setting range:	0.1 to 500.0 (rotary)* 1 to 15999999 (linear)*	1 to 5000 (rotary)* 1 to 15999999 (linear)*		
Format:	DEC	DEC	-	-
Example:	1.5 = 1.5 rpm 15 = 15 μm/s	15 = 1.5 rpm 15 = 15 μm/s	-	-

Settings:

The second speed setting for low speed homing.

Note: rotary means a permanent-magnet synchronous rotary motor; linear means a permanent-magnet synchronous linear motor.

8

<b>P5.007</b>	<b>Trigger Position command (PR mode only)</b>		<b>Address: 050EH 050FH</b>
Default:	0	Control mode:	PR
Unit:	-	Setting range:	0 to 1000
Format:	DEC	Data size:	16-bit

Settings:

1. Set P5.007 to 0 to start homing.
2. Set P5.007 to 1 - 99 to execute the specified PR procedure, which is the same as using DI.CTRG+POS<sub>n</sub>. You cannot set P5.007 to 100 - 999 as the value exceeds the valid range.

Example: to trigger PR#2

Method 1	Trigger by DI: Register Position command selection 1 - 99 Bit1 (DI: 0x12) + Command triggered (DI: 0x08)
Method 2	Trigger by P5.007: Set P5.007 to 2 to start executing PR#2

3. Set P5.007 to 1000 to execute the stop command which is the same as DI.STP.
4. When reading P5.007, if the command is incomplete and DO.TPOS is off (the motor does not reach the target position), the drive reads the current command (1 - 99). If the command is complete, the drive reads the current command +10000. If the command is complete and DO.TPOS is on (the motor reaches the target position), the drive reads the current command +20000. Commands triggered by DI are also applicable.

Example:

If the value read is 3, it means PR#3 is being executed and not yet complete. If the value read is 10003, it means PR#3 is complete, but the motor has not reached the target position yet.

If the value read is 20003, it means PR#3 is complete and the motor reached the target position.

<b>P5.008</b>	<b>Positive software limit</b>		<b>Address: 0510H 0511H</b>
Default:	2147483647	Control mode:	PR
Unit:	PUU	Setting range:	-2147483648 to +2147483647
Format:	DEC	Data size:	32-bit

Settings:

In PR mode, if the motor moves in the positive direction and its feedback position exceeds the value of P5.008, AL283 occurs.

<b>P5.009</b>	<b>Negative software limit</b>		<b>Address: 0512H 0513H</b>	
Default:	-2147483648	Control mode:	PR	
Unit:	PUU	Setting range:	-2147483648 to +2147483647	
Format:	DEC	Data size:	32-bit	

Settings:

In PR mode, if the motor moves in the negative direction and its feedback position exceeds the value of P5.009, AL285 occurs.

<b>P5.010★■</b>	<b>Data array: data size</b>		<b>Address: 0514H 0515H</b>	
Default:	-	Control mode:	All	
Unit:	-	Setting range:	Read-only	
Format:	DEC	Data size:	16-bit	

Settings:

The total data size is N x 32 bits, where N indicates the number of data sets returned to the data array.

<b>P5.011■</b>	<b>Data array: address for reading and writing</b>		<b>Address: 0516H 0517H</b>	
Default:	0	Control mode:	All	
Unit:	-	Setting range:	0 to (value set by P5.010 minus 1)	
Format:	DEC	Data size:	16-bit	

Settings:

Specify the address to read or write the data array. Refer to Chapter 7 for detailed instructions.

<b>P5.012■</b>	<b>Data array: window #1 for reading and writing</b>		<b>Address: 0518H 0519H</b>	
Default:	0	Control mode:	All	
Unit:	-	Setting range:	-2147483648 to +2147483647	
Format:	DEC	Data size:	32-bit	

Settings:

Window #1: when read with the panel, the value set by P5.011 does not add 1, but when read or written by other methods, it adds 1.

Refer to Section 7.2.1 Data array for detailed instructions.

8

<b>P5.013</b>	<b>Data array: window #2 for reading and writing</b>		<b>Address: 051AH 051BH</b>
Default:	0	Control mode:	All
Unit:	-	Setting range:	-2147483648 to +2147483647
Format:	DEC	Data size:	32-bit

Settings:

Window #2: when read with the panel or read and written through communication, the value set by P5.011 adds 1, but this parameter is not writable with the panel.

Refer to Section 7.2.1 Data array for detailed instructions.

<b>P5.014</b>	<b>Reserved</b>
---------------	-----------------

<b>P5.015</b>	<b>PATH 1 - PATH 2 volatile setting</b>		<b>Address: 051EH 051FH</b>
Default:	0x0000	Control mode:	PR
Unit:	-	Setting range:	0x0000 - 0x0011
Format:	HEX	Data size:	16-bit

Settings:

This parameter allows you to write data to the target continuously through communication.



X	PATH 1 volatile setting	Z	Reserved
Y	PATH 2 volatile setting	U	Reserved

- X: PATH 1 volatile setting
  - 0: non-volatile
  - 1: volatile
- Y: PATH 2 volatile setting
  - 0: non-volatile
  - 1: volatile

<b>P5.016</b>	<b>Axis position - main encoder</b>		<b>Address: 0520H 0521H</b>	
Default:	0	Control mode:	All	
Unit:	PUU	Setting range:	-2147483648 to +2147483647	
Format:	DEC	Data size:	32-bit	

Settings:

Read: feedback position of the main encoder, which is the monitoring variable 000 (00h) + offset value (value written in P5.016).

Write: writing any value to the parameter neither changes the monitoring variable 000 (00h) nor affects the position system. It is only for adjusting the offset value when observation.

<b>P5.017</b>	<b>Axis position - auxiliary encoder</b>		<b>Address: 0522H 0523H</b>	
Default:	0	Control mode:	All	
Unit:	pulse	Setting range:	-2147483648 to +2147483647	
Format:	DEC	Data size:	32-bit	

Settings:

Pulse counts of the auxiliary encoder.

<b>P5.018</b>	<b>Axis position - pulse command</b>		<b>Address: 0524H 0525H</b>	
Default:	0	Control mode:	All	
Unit:	pulse	Setting range:	-2147483648 to +2147483647	
Format:	DEC	Data size:	32-bit	

Settings:

Pulse count from the pulse command.

<b>P5.019</b>	<b>E-Cam: curve scaling</b>		<b>Address: 0526H 0527H</b>	
Default:	1.000000	Control mode:	PR	
Unit:	0.000001 times, which is 1 / (10 <sup>6</sup> )	Setting range:	-2147.000000 to +2147.000000	
Format:	DEC	Data size:	32-bit	
Example:	1100000 = 1.1 times			

Settings:

Use this parameter to magnify or reduce the E-Cam table without changing the values.

Example: when the data in the table is 0, 10, 20, 30, 40, 20, and the magnification is set to 2.000000, then the data equals the data: 0, 20, 40, 60, 80, 40, with the magnification as 1.000000. This enables the operation of E-Cam with the same pulse frequency of the master axis. Magnification enlarges both the route of E-Cam operation and the speed.

Note: this parameter can be set at any time, but the time when it becomes effective is determined by P5.088.X [Bit 2].

8

<b>P5.020</b>	<b>Acceleration / deceleration time #0</b>		<b>Address: 0528H 0529H</b>	
Default:	200	Control mode:	PR	
Unit:	ms (P2.068.U = 0) 10 ms (P2.068.U = 1)	Setting range:	1 to 65500	
Format:	DEC	Data size:	16-bit	

Settings:

The time setting for acceleration / deceleration in PR mode.

Rotary motor: the duration to accelerate from 0 to 3,000 rpm.

Linear motor: the duration to accelerate from 0 to 5 m/s.

<b>P5.021</b>	<b>Acceleration / deceleration time #1</b>		<b>Address: 052AH 052BH</b>	
Default:	300	Control mode:	PR	
Unit:	ms (P2.068.U = 0) 10 ms (P2.068.U = 1)	Setting range:	1 to 65500	
Format:	DEC	Data size:	16-bit	

Settings:

The time setting for acceleration and deceleration in PR mode. Refer to P5.020 for details.

<b>P5.022</b>	<b>Acceleration / deceleration time #2</b>		<b>Address: 052CH 052DH</b>	
Default:	500	Control mode:	PR	
Unit:	ms (P2.068.U = 0) 10 ms (P2.068.U = 1)	Setting range:	1 to 65500	
Format:	DEC	Data size:	16-bit	

Settings:

The time setting for acceleration and deceleration in PR mode. Refer to P5.020 for details.

<b>P5.023</b>	<b>Acceleration / deceleration time #3</b>		<b>Address: 052EH 052FH</b>	
Default:	600	Control mode:	PR	
Unit:	ms (P2.068.U = 0) 10 ms (P2.068.U = 1)	Setting range:	1 to 65500	
Format:	DEC	Data size:	16-bit	

Settings:

The time setting for acceleration and deceleration in PR mode. Refer to P5.020 for details.

<b>P5.024</b>	<b>Acceleration / deceleration time #4</b>		<b>Address: 0530H 0531H</b>
Default:	800	Control mode:	PR
Unit:	ms (P2.068.U = 0) 10 ms (P2.068.U = 1)	Setting range:	1 to 65500
Format:	DEC	Data size:	16-bit

Settings:

The time setting for acceleration and deceleration in PR mode. Refer to P5.020 for details.

<b>P5.025</b>	<b>Acceleration / deceleration time #5</b>		<b>Address: 0532H 0533H</b>
Default:	900	Control mode:	PR
Unit:	ms (P2.068.U = 0) 10 ms (P2.068.U = 1)	Setting range:	1 to 65500
Format:	DEC	Data size:	16-bit

Settings:

The time setting for acceleration and deceleration in PR mode. Refer to P5.020 for details.

<b>P5.026</b>	<b>Acceleration / deceleration time #6</b>		<b>Address: 0534H 0535H</b>
Default:	1000	Control mode:	PR
Unit:	ms (P2.068.U = 0) 10 ms (P2.068.U = 1)	Setting range:	1 to 65500
Format:	DEC	Data size:	16-bit

Settings:

The time setting for acceleration and deceleration in PR mode. Refer to P5.020 for details.

<b>P5.027</b>	<b>Acceleration / deceleration time #7</b>		<b>Address: 0536H 0537H</b>
Default:	1200	Control mode:	PR
Unit:	ms (P2.068.U = 0) 10 ms (P2.068.U = 1)	Setting range:	1 to 65500
Format:	DEC	Data size:	16-bit

Settings:

The time setting for acceleration and deceleration in PR mode. Refer to P5.020 for details.

<b>P5.028</b>	<b>Acceleration / deceleration time #8</b>		<b>Address: 0538H 0539H</b>
Default:	1500	Control mode:	PR
Unit:	ms (P2.068.U = 0) 10 ms (P2.068.U = 1)	Setting range:	1 to 65500
Format:	DEC	Data size:	16-bit

Settings:

The time setting for acceleration and deceleration in PR mode. Refer to P5.020 for details.



8

<b>P5.029</b>	<b>Acceleration / deceleration time #9</b>		<b>Address: 053AH 053BH</b>	
Default:	2000	Control mode:	PR	
Unit:	ms (P2.068.U = 0) 10 ms (P2.068.U = 1)	Setting range:	1 to 65500	
Format:	DEC	Data size:	16-bit	

Settings:

The time setting for acceleration and deceleration in PR mode. Refer to P5.020 for details.

<b>P5.030</b>	<b>Acceleration / deceleration time #10</b>		<b>Address: 053CH 053DH</b>	
Default:	2500	Control mode:	PR	
Unit:	ms (P2.068.U = 0) 10 ms (P2.068.U = 1)	Setting range:	1 to 65500	
Format:	DEC	Data size:	16-bit	

Settings:

The time setting for acceleration and deceleration in PR mode. Refer to P5.020 for details.

<b>P5.031</b>	<b>Acceleration / deceleration time #11</b>		<b>Address: 053EH 053FH</b>	
Default:	3000	Control mode:	PR	
Unit:	ms (P2.068.U = 0) 10 ms (P2.068.U = 1)	Setting range:	1 to 65500	
Format:	DEC	Data size:	16-bit	

Settings:

The time setting for acceleration and deceleration in PR mode. Refer to P5.020 for details.

<b>P5.032</b>	<b>Acceleration / deceleration time #12</b>		<b>Address: 0540H 0541H</b>	
Default:	5000	Control mode:	PR	
Unit:	ms (P2.068.U = 0) 10 ms (P2.068.U = 1)	Setting range:	1 to 65500	
Format:	DEC	Data size:	16-bit	

Settings:

The time setting for acceleration and deceleration in PR mode. Refer to P5.020 for details.

<b>P5.033</b>	<b>Acceleration / deceleration time #13</b>		<b>Address: 0542H 0543H</b>	
Default:	8000	Control mode:	PR	
Unit:	ms (P2.068.U = 0) 10 ms (P2.068.U = 1)	Setting range:	1 to 65500	
Format:	DEC	Data size:	16-bit	

Settings:

The time setting for acceleration and deceleration in PR mode. Refer to P5.020 for details.

<b>P5.034</b>	<b>Acceleration / deceleration time #14</b>		<b>Address: 0544H 0545H</b>
Default:	50	Control mode:	PR
Unit:	ms (P2.068.U = 0) 10 ms (P2.068.U = 1)	Setting range:	1 to 1500
Format:	DEC	Data size:	16-bit

Settings:

The deceleration time setting for auto-protection. The default value is small for faster deceleration.

<b>P5.035</b>	<b>Acceleration / deceleration time #15</b>		<b>Address: 0546H 0547H</b>
Default:	30	Control mode:	PR
Unit:	ms (P2.068.U = 0) 10 ms (P2.068.U = 1)	Setting range:	1 to 1200
Format:	DEC	Data size:	16-bit

Settings:

The deceleration time for auto-protection. The default value is small for faster deceleration.

<b>P5.036</b>	<b>Capture: start address of data array</b>		<b>Address: 0548H 0549H</b>
Default:	0	Control mode:	All
Unit:	-	Setting range:	0 to (value set by P5.010 minus 1)
Format:	DEC	Data size:	16-bit

Settings:

Specifies the address of the data array to save the first data to be captured. This parameter is only writable when Capture stops (refer to P5.039).

<b>P5.037■</b>	<b>Capture: axis position</b>		<b>Address: 054AH 054BH</b>
Default:	0	Control mode:	All
Unit:	Pulse unit of capture source	Setting range:	-2147483648 to +2147483647
Format:	DEC	Data size:	32-bit

Settings:

Displays the axis position of the Capture pulse source. Note that this parameter is only writable when Capture stops (refer to P5.039). If the pulse source of Capture is the main encoder, this parameter is write-protected and the axis position is the feedback position of the motor (monitoring variable 00h).

8

<b>P5.038</b>	<b>Capture: number of capturing times</b>		<b>Address: 054CH 054DH</b>
Default:	1	Control mode:	All
Unit:	-	Setting range:	1 to (value set by P5.010 minus value set by P5.036)
Format:	DEC	Data size:	16-bit

Settings:

When Capture is not in operation, this parameter indicates the number of data sets expected to be captured (readable and writable). When Capture is in operation, this parameter indicates the remaining number of data sets to be captured (read-only). Each time one data is captured, the value of P5.038 decrements by 1 until the value is 0, indicating that capturing is complete.

Note: the total number of data sets from Compare, Capture, and E-Cam cannot exceed 800.

<b>P5.039</b>	<b>Capture: activate CAP control</b>		<b>Address: 054EH 054FH</b>
Default:	0x2010	Control mode:	All
Unit:	-	Setting range:	0x0000 - 0xF13F
Format:	HEX	Data size:	16-bit

Settings:



X	Capture setting	Z	Trigger logic
Y	Axis source of Capture	U	Minimum interval between each trigger

■ X: Capture setting

Bit	Function	Description
0	Activate Capture	Start capturing; after capturing is complete, set this bit to 0 automatically (Capture disabled).
1	Reset position	After capturing the first data, reset the position of the first data. The position of the reset point is set by P5.076.
2	Activate Compare	After capturing the first data, activate Compare, but this setting is invalid if Compare is already activated.
3	Execute PR	Execute PR#50 automatically after capturing is complete.

■ Y: axis source of Capture

- 0: Capture is not working
- 1: CN5
- 2: CN1 (pulse command)
- 3: CN2

Note: when the source of Compare is the Capture axis, the source of Capture (P5.039.Y) cannot be changed.

■ Z: trigger logic

- 0: NO (normally open)
- 1: NC (normally closed)

- U: minimum interval between each trigger  
0 - F: 0 - 15 ms

Note: refer to Chapter 7 for detailed instructions for Capture.

<b>P5.040</b>	<b>Delay time #0 after position reached</b>		<b>Address: 0550H 0551H</b>
Default:	0	Control mode:	PR
Unit:	ms	Setting range:	0 to 32767
Format:	DEC	Data size:	16-bit

Settings:

There are 16 sets of delay time (#0 - 15) in PR mode. This parameter is the delay time #0 in PR mode.

<b>P5.041</b>	<b>Delay time #1 after position reached</b>		<b>Address: 0552H 0553H</b>
Default:	100	Control mode:	PR
Unit:	ms	Setting range:	0 to 32767
Format:	DEC	Data size:	16-bit

Settings:

Delay time #1 in PR mode.

<b>P5.042</b>	<b>Delay time #2 after position reached</b>		<b>Address: 0554H 0555H</b>
Default:	200	Control mode:	PR
Unit:	ms	Setting range:	0 to 32767
Format:	DEC	Data size:	16-bit

Settings:

Delay time #2 in PR mode.

<b>P5.043</b>	<b>Delay time #3 after position reached</b>		<b>Address: 0556H 0557H</b>
Default:	400	Control mode:	PR
Unit:	ms	Setting range:	0 to 32767
Format:	DEC	Data size:	16-bit

Settings:

Delay time #3 in PR mode.

8

<b>P5.044</b>	<b>Delay time #4 after position reached</b>		<b>Address: 0558H 0559H</b>
Default:	500	Control mode:	PR
Unit:	ms	Setting range:	0 to 32767
Format:	DEC	Data size:	16-bit

Settings:

Delay time #4 in PR mode.

<b>P5.045</b>	<b>Delay time #5 after position reached</b>		<b>Address: 055AH 055BH</b>
Default:	800	Control mode:	PR
Unit:	ms	Setting range:	0 to 32767
Format:	DEC	Data size:	16-bit

Settings:

Delay time #5 in PR mode.

<b>P5.046</b>	<b>Delay time #6 after position reached</b>		<b>Address: 055CH 055DH</b>
Default:	1000	Control mode:	PR
Unit:	ms	Setting range:	0 to 32767
Format:	DEC	Data size:	16-bit

Settings:

Delay time #6 in PR mode.

<b>P5.047</b>	<b>Delay time #7 after position reached</b>		<b>Address: 055EH 055FH</b>
Default:	1500	Control mode:	PR
Unit:	ms	Setting range:	0 to 32767
Format:	DEC	Data size:	16-bit

Settings:

Delay time #7 in PR mode.

<b>P5.048</b>	<b>Delay time #8 after position reached</b>		<b>Address: 0560H 0561H</b>
Default:	2000	Control mode:	PR
Unit:	ms	Setting range:	0 to 32767
Format:	DEC	Data size:	16-bit

Settings:

Delay time #8 in PR mode.

<b>P5.049</b>	<b>Delay time #9 after position reached</b>		<b>Address: 0562H 0563H</b>	
Default:	2500	Control mode:	PR	
Unit:	ms	Setting range:	0 to 32767	
Format:	DEC	Data size:	16-bit	

Settings:

Delay time #9 in PR mode.

<b>P5.050</b>	<b>Delay time #10 after position reached</b>		<b>Address: 0564H 0565H</b>	
Default:	3000	Control mode:	PR	
Unit:	ms	Setting range:	0 to 32767	
Format:	DEC	Data size:	16-bit	

Settings:

Delay time #10 in PR mode.

<b>P5.051</b>	<b>Delay time #11 after position reached</b>		<b>Address: 0566H 0567H</b>	
Default:	3500	Control mode:	PR	
Unit:	ms	Setting range:	0 to 32767	
Format:	DEC	Data size:	16-bit	

Settings:

Delay time #11 in PR mode.

<b>P5.052</b>	<b>Delay time #12 after position reached</b>		<b>Address: 0568H 0569H</b>	
Default:	4000	Control mode:	PR	
Unit:	ms	Setting range:	0 to 32767	
Format:	DEC	Data size:	16-bit	

Settings:

Delay time #12 in PR mode.

<b>P5.053</b>	<b>Delay time #13 after position reached</b>		<b>Address: 056AH 056BH</b>	
Default:	4500	Control mode:	PR	
Unit:	ms	Setting range:	0 to 32767	
Format:	DEC	Data size:	16-bit	

Settings:

Delay time #13 in PR mode.

8

<b>P5.054</b>	<b>Delay time #14 after position reached</b>		<b>Address: 056CH 056DH</b>	
Default:	5000	Control mode:	PR	
Unit:	ms	Setting range:	0 to 32767	
Format:	DEC	Data size:	16-bit	

Settings:

Delay time #14 in PR mode.

<b>P5.055</b>	<b>Delay time #15 after position reached</b>		<b>Address: 056EH 056FH</b>	
Default:	5500	Control mode:	PR	
Unit:	ms	Setting range:	0 to 32767	
Format:	DEC	Data size:	16-bit	

Settings:

Delay time #15 in PR mode.

<b>P5.056</b>	<b>Compare: start address of data array</b>		<b>Address: 0570H 0571H</b>	
Default:	50	Control mode:	All	
Unit:	-	Setting range:	0 to (value set by P5.010 minus 1)	
Format:	DEC	Data size:	16-bit	

Settings:

Specifies the address of the data array to save the first data to be compared. This parameter is only writable when Compare stops (refer to P5.059).

<b>P5.057</b>	<b>Compare: axis position</b>		<b>Address: 0572H 0573H</b>	
Default:	0	Control mode:	All	
Unit:	Pulse unit of compare source	Setting range:	-2147483648 to +2147483647	
Format:	DEC	Data size:	32-bit	

Settings:

Displays the axis position of the Compare pulse source. Note that this parameter is only writable when Compare stops (refer to P5.059).

Note:

1. This parameter is write-protected when the axis source of Compare is the Capture axis (P5.059.Y = 0).
2. This parameter is also write-protected when the axis source of Compare is CN2, and the pulse resolution is determined by P1.046. When you set the axis source of Compare to CN2 (P5.059.Y = 3), this parameter is reset to the feedback position of the motor (monitoring variable 00h). When the motor feedback position is redefined due to homing or Capture, the motor feedback position is different from the value of this parameter. In this case, set P5.059.Y to 0 and then to 3 to reset this parameter to the motor feedback position.

<b>P5.058</b>	<b>Compare: number of comparing times</b>		<b>Address: 0574H 0575H</b>
Default:	1	Control mode:	All
Unit:	-	Setting range:	1 to (value set by P5.010 minus value set by P5.056)
Format:	DEC	Data size:	16-bit

Settings:

When Compare is not in operation, this parameter indicates the number of data sets expected to be compared (readable and writable). When Compare is in operation, this parameter indicates the remaining number of data sets to be compared (read-only). Each time one data is compared, the value of P5.058 decrements by 1 until the value is 0, indicating that comparing is complete.

Note: the total number of data sets from Compare, Capture, and E-Cam cannot exceed 800.

<b>P5.059</b>	<b>Compare: activate CMP control</b>		<b>Address: 0576H 0577H</b>
Default:	0x00640010	Control mode:	All
Unit:	-	Setting range:	0x00010000 - 0x0FFF313F
Format:	HEX	Data size:	32-bit

Settings:



CBA	Duration of pulse output	X	Compare setting
D	N/A	Y	Axis source of Compare
-	-	Z	Trigger logic
-	-	U	Trigger PR

■ X: Compare setting

Bit	Function	Description
0	Activate Compare	Start comparing; after comparing is complete, set this bit to 0 automatically (Compare disabled).
1	Cycle mode	When the number of comparing times (P5.058) is 0, reset the number of comparing times to the default setting automatically.
2	Activate Capture	After comparing is complete, activate Capture, but this setting is invalid if Capture is already activated.
3	Position returns to 0	When the last data is compared, return the Compare axis position (P5.057) to 0.

■ Y: axis source of Compare

0: Capture axis

1: CN5

2: CN1 (pulse command)

3: CN2

Note: when the source of Compare is the Capture axis, the source of Capture (P5.039.Y) cannot be changed.



## 8

- Z: trigger logic
  - 0: NO (normally open)
  - 1: NC (normally closed)

- U: trigger PR

Bit	Function	Description
0	Execute PR	Execute PR#45 automatically after comparing is complete.
1 to 3	Reserved	-

- CBA: duration of pulse output (unit: 1 ms)

Note: refer to Chapter 7 for detailed instructions for Compare.

P5.060	Target speed setting #0			Address: 0578H 0579H
Operation interface:	Panel / software	Communication	Control mode:	PR
Default:	20.0 (rotary)* 20 (linear)*	200	Data size:	32-bit
Unit:	1 rpm (rotary)* 1 $\mu$ m/s (linear)*	0.1 rpm (rotary)* 1 $\mu$ m/s (linear)*		
Setting range:	0.0 to 7500.0 (rotary)* 0 to 15999999 (linear)*	0 to 75000 (rotary)* 0 to 15999999 (linear)*		
Format:	DEC	-	-	-
Example:	1.0 = 1 rpm (rotary)* 1 = 1 $\mu$ m/s (linear)*	10 = 1 rpm (rotary)* 1 = 1 $\mu$ m/s (linear)*	-	-

Settings:

Target speed #0 of PR mode.

Note: rotary means a permanent-magnet synchronous rotary motor; linear means a permanent-magnet synchronous linear motor.

P5.061	Target speed setting #1			Address: 057AH 057BH
Operation interface:	Panel / software	Communication	Control mode:	PR
Default:	50.0 (rotary)* 50 (linear)*	500	Data size:	32-bit
Unit:	1 rpm (rotary)* 1 $\mu$ m/s (linear)*	0.1 rpm (rotary)* 1 $\mu$ m/s (linear)*		
Setting range:	0.0 to 7500.0 (rotary)* 0 to 15999999 (linear)*	0 to 75000 (rotary)* 0 to 15999999 (linear)*		
Format:	DEC	-	-	-
Example:	1.0 = 1 rpm (rotary)* 1 = 1 $\mu$ m/s (linear)*	10 = 1 rpm (rotary)* 1 = 1 $\mu$ m/s (linear)*	-	-

Settings:

Target speed #1 of PR mode.

Note: rotary means a permanent-magnet synchronous rotary motor; linear means a permanent-magnet synchronous linear motor.

P5.062	Target speed setting #2			Address: 057CH 057DH
Operation interface:	Panel / software	Communication	Control mode:	PR
Default:	100.0 (rotary)* 100 (linear)*	1000	Data size:	32-bit
Unit:	1 rpm (rotary)* 1 $\mu$ m/s (linear)*	0.1 rpm (rotary)* 1 $\mu$ m/s (linear)*		
Setting range:	0.0 to 7500.0 (rotary)* 0 to 15999999 (linear)*	0 to 75000 (rotary)* 0 to 15999999 (linear)*		
Format:	DEC	-	-	-
Example:	1.0 = 1 rpm (rotary)* 1 = 1 $\mu$ m/s (linear)*	10 = 1 rpm (rotary)* 1 = 1 $\mu$ m/s (linear)*	-	-

Settings:

Target speed #2 of PR mode.

Note: rotary means a permanent-magnet synchronous rotary motor; linear means a permanent-magnet synchronous linear motor.

P5.063	Target speed setting #3			Address: 057EH 057FH
Operation interface:	Panel / software	Communication	Control mode:	PR
Default:	200.0 (rotary)* 200 (linear)*	2000	Data size:	32-bit
Unit:	1 rpm (rotary)* 1 $\mu$ m/s (linear)*	0.1 rpm (rotary)* 1 $\mu$ m/s (linear)*		
Setting range:	0.0 to 7500.0 (rotary)* 0 to 15999999 (linear)*	0 to 75000 (rotary)* 0 to 15999999 (linear)*		
Format:	DEC	-	-	-
Example:	1.0 = 1 rpm (rotary)* 1 = 1 $\mu$ m/s (linear)*	10 = 1 rpm (rotary)* 1 = 1 $\mu$ m/s (linear)*	-	-

Settings:

Target speed #3 of PR mode.

Note: rotary means a permanent-magnet synchronous rotary motor; linear means a permanent-magnet synchronous linear motor.

8

P5.064	Target speed setting #4			Address: 0580H 0581H
Operation interface:	Panel / software	Communication	Control mode:	PR
Default:	300.0 (rotary)* 300 (linear)*	3000	Data size:	32-bit
Unit:	1 rpm (rotary)* 1 $\mu$ m/s (linear)*	0.1 rpm (rotary)* 1 $\mu$ m/s (linear)*		
Setting range:	0.0 to 7500.0 (rotary)* 0 to 15999999 (linear)*	0 to 75000 (rotary)* 0 to 15999999 (linear)*		
Format:	DEC	-	-	-
Example:	1.0 = 1 rpm (rotary)* 1 = 1 $\mu$ m/s (linear)*	10 = 1 rpm (rotary)* 1 = 1 $\mu$ m/s (linear)*	-	-

Settings:

Target speed #4 of PR mode.

Note: rotary means a permanent-magnet synchronous rotary motor; linear means a permanent-magnet synchronous linear motor.

P5.065	Target speed setting #5			Address: 0582H 0583H
Operation interface:	Panel / software	Communication	Control mode:	PR
Default:	500.0 (rotary)* 500 (linear)*	5000	Data size:	32-bit
Unit:	1 rpm (rotary)* 1 $\mu$ m/s (linear)*	0.1 rpm (rotary)* 1 $\mu$ m/s (linear)*		
Setting range:	0.0 to 7500.0 (rotary)* 0 to 15999999 (linear)*	0 to 75000 (rotary)* 0 to 15999999 (linear)*		
Format:	DEC	-	-	-
Example:	1.0 = 1 rpm (rotary)* 1 = 1 $\mu$ m/s (linear)*	10 = 1 rpm (rotary)* 1 = 1 $\mu$ m/s (linear)*	-	-

Settings:

Target speed #5 of PR mode.

Note: rotary means a permanent-magnet synchronous rotary motor; linear means a permanent-magnet synchronous linear motor.

P5.066	Target speed setting #6			Address: 0584H 0585H
Operation interface:	Panel / software	Communication	Control mode:	PR
Default:	600.0 (rotary)* 600 (linear)*	6000	Data size:	32-bit
Unit:	1 rpm (rotary)* 1 $\mu$ m/s (linear)*	0.1 rpm (rotary)* 1 $\mu$ m/s (linear)*		
Setting range:	0.0 to 7500.0 (rotary)* 0 to 15999999 (linear)*	0 to 75000 (rotary)* 0 to 15999999 (linear)*		
Format:	DEC	-	-	-
Example:	1.0 = 1 rpm (rotary)* 1 = 1 $\mu$ m/s (linear)*	10 = 1 rpm (rotary)* 1 = 1 $\mu$ m/s (linear)*	-	-

Settings:

Target speed #6 of PR mode.

Note: rotary means a permanent-magnet synchronous rotary motor; linear means a permanent-magnet synchronous linear motor.

P5.067	Target speed setting #7			Address: 0586H 0587H
Operation interface:	Panel / software	Communication	Control mode:	PR
Default:	800.0 (rotary)* 800 (linear)*	8000	Data size:	32-bit
Unit:	1 rpm (rotary)* 1 $\mu$ m/s (linear)*	0.1 rpm (rotary)* 1 $\mu$ m/s (linear)*		
Setting range:	0.0 to 7500.0 (rotary)* 0 to 15999999 (linear)*	0 to 75000 (rotary)* 0 to 15999999 (linear)*		
Format:	DEC	-	-	-
Example:	1.0 = 1 rpm (rotary)* 1 = 1 $\mu$ m/s (linear)*	10 = 1 rpm (rotary)* 1 = 1 $\mu$ m/s (linear)*	-	-

Settings:

Target speed #7 of PR mode.

Note: rotary means a permanent-magnet synchronous rotary motor; linear means a permanent-magnet synchronous linear motor.

8

P5.068	Target speed setting #8			Address: 0588H 0589H
Operation interface:	Panel / software	Communication	Control mode:	PR
Default:	1000.0 (rotary)* 1000 (linear)*	10000	Data size:	32-bit
Unit:	1 rpm (rotary)* 1 $\mu$ m/s (linear)*	0.1 rpm (rotary)* 1 $\mu$ m/s (linear)*		
Setting range:	0.0 to 7500.0 (rotary)* 0 to 15999999 (linear)*	0 to 75000 (rotary)* 0 to 15999999 (linear)*		
Format:	DEC	-	-	
Example:	1.0 = 1 rpm (rotary)* 1 = 1 $\mu$ m/s (linear)*	10 = 1 rpm (rotary)* 1 = 1 $\mu$ m/s (linear)*	-	-

Settings:

Target speed #8 of PR mode.

Note: rotary means a permanent-magnet synchronous rotary motor; linear means a permanent-magnet synchronous linear motor.

P5.069	Target speed setting #9			Address: 058AH 058BH
Operation interface:	Panel / software	Communication	Control mode:	PR
Default:	1300.0 (rotary)* 1300 (linear)*	13000	Data size:	32-bit
Unit:	1 rpm (rotary)* 1 $\mu$ m/s (linear)*	0.1 rpm (rotary)* 1 $\mu$ m/s (linear)*		
Setting range:	0.0 to 7500.0 (rotary)* 0 to 15999999 (linear)*	0 to 75000 (rotary)* 0 to 15999999 (linear)*		
Format:	DEC	-	-	
Example:	1.0 = 1 rpm (rotary)* 1 = 1 $\mu$ m/s (linear)*	10 = 1 rpm (rotary)* 1 = 1 $\mu$ m/s (linear)*	-	-

Settings:

Target speed #9 of PR mode.

Note: rotary means a permanent-magnet synchronous rotary motor; linear means a permanent-magnet synchronous linear motor.

P5.070	Target speed setting #10			Address: 058CH 058DH
Operation interface:	Panel / software	Communication	Control mode:	PR
Default:	1500.0 (rotary)* 1500 (linear)*	15000	Data size:	32-bit
Unit:	1 rpm (rotary)* 1 $\mu$ m/s (linear)*	0.1 rpm (rotary)* 1 $\mu$ m/s (linear)*		
Setting range:	0.0 to 7500.0 (rotary)* 0 to 15999999 (linear)*	0 to 75000 (rotary)* 0 to 15999999 (linear)*		
Format:	DEC	-	-	
Example:	1.0 = 1 rpm (rotary)* 1 = 1 $\mu$ m/s (linear)*	10 = 1 rpm (rotary)* 1 = 1 $\mu$ m/s (linear)*	-	-

Settings:

Target speed #10 of PR mode.

Note: rotary means a permanent-magnet synchronous rotary motor; linear means a permanent-magnet synchronous linear motor.

P5.071	Target speed setting #11			Address: 058EH 058FH
Operation interface:	Panel / software	Communication	Control mode:	PR
Default:	1800.0 (rotary)* 1800 (linear)*	18000	Data size:	32-bit
Unit:	1 rpm (rotary)* 10 μm/s (linear)*	0.1 rpm (rotary)* 10 μm/s (linear)*		
Setting range:	0.0 to 7500.0 (rotary)* 0 to 15999999 (linear)*	0 to 75000 (rotary)* 0 to 15999999 (linear)*		
Format:	DEC	-	-	-
Example:	1.0 = 1 rpm (rotary)* 1 = 1 μm/s (linear)*	10 = 1 rpm (rotary)* 1 = 1 μm/s (linear)	-	-

Settings:

Target speed #11 of PR mode.

Note: rotary means a permanent-magnet synchronous rotary motor; linear means a permanent-magnet synchronous linear motor.

P5.072	Target speed setting #12			Address: 0590H 0591H
Operation interface:	Panel / software	Communication	Control mode:	PR
Default:	2000.0 (rotary)* 2000 (linear)*	20000	Data size:	32-bit
Unit:	1 rpm (rotary)* 1 μm/s (linear)*	0.1 rpm (rotary)* 1 μm/s (linear)*		
Setting range:	0.0 to 7500.0 (rotary)* 0 to 15999999 (linear)*	0 to 75000 (rotary)* 0 to 15999999 (linear)*		
Format:	DEC	-	-	-
Example:	1.0 = 1 rpm (rotary)* 1 = 1 μm/s (linear)*	10 = 1 rpm (rotary)* 1 = 1 μm/s (linear)*	-	-

Settings:

Target speed #12 of PR mode.

Note: rotary means a permanent-magnet synchronous rotary motor; linear means a permanent-magnet synchronous linear motor.

P5.073	Target speed setting #13			Address: 0592H 0593H
Operation interface:	Panel / software	Communication	Control mode:	PR
Default:	2300.0 (rotary)* 2300 (linear)*	23000	Data size:	32-bit
Unit:	1 rpm (rotary)* 1 μm/s (linear)*	0.1 rpm (rotary)* 1 μm/s (linear)*		
Setting range:	0.0 to 7500.0 (rotary)* 0 to 15999999 (linear)*	0 to 75000 (rotary)* 0 to 15999999 (linear)*		
Format:	DEC	-	-	-
Example:	1.0 = 1 rpm (rotary)* 1 = 1 μm/s (linear)*	10 = 1 rpm (rotary)* 1 = 1 μm/s (linear)*	-	-

Settings:

Target speed #13 of PR mode.

Note: rotary means a permanent-magnet synchronous rotary motor; linear means a permanent-magnet synchronous linear motor.

8

<b>P5.074</b>	<b>Target speed setting #14</b>			<b>Address: 0594H 0595H</b>
Operation interface:	Panel / software	Communication	Control mode:	PR
Default:	2500.0 (rotary)* 2500 (linear)*	25000	Data size:	32-bit
Unit:	1 rpm (rotary)* 1 $\mu$ m/s (linear)*	0.1 rpm (rotary)* 1 $\mu$ m/s (linear)*		
Setting range:	0.0 to 7500.0 (rotary)* 0 to 15999999 (linear)*	0 to 75000 (rotary)* 0 to 15999999 (linear)*		
Format:	DEC	-	-	
Example:	1.0 = 1 rpm (rotary)* 1 = 1 $\mu$ m/s (linear)*	10 = 1 rpm (rotary)* 1 = 1 $\mu$ m/s (linear)*	-	-

Settings:

Target speed #14 of PR mode.

Note: rotary means a permanent-magnet synchronous rotary motor; linear means a permanent-magnet synchronous linear motor.

<b>P5.075</b>	<b>Target speed setting #15</b>			<b>Address: 0596H 0597H</b>
Operation interface:	Panel / software	Communication	Control mode:	PR
Default:	3000.0 (rotary)* 3000 (linear)*	30000	Data size:	32-bit
Unit:	1 rpm (rotary)* 1 $\mu$ m/s (linear)*	0.1 rpm (rotary)* 1 $\mu$ m/s (linear)*		
Setting range:	0.0 to 7500.0 (rotary)* 0 to 15999999 (linear)*	0 to 75000 (rotary)* 0 to 15999999 (linear)*		
Format:	DEC	-	-	
Example:	1.0 = 1 rpm (rotary)* 1 = 1 $\mu$ m/s (linear)*	10 = 1 rpm (rotary)* 1 = 1 $\mu$ m/s (linear)*	-	-

Settings:

Target speed #15 of PR mode.

Note: rotary means a permanent-magnet synchronous rotary motor; linear means a permanent-magnet synchronous linear motor.

<b>P5.076</b>	<b>Capture: reset position after first data captured</b>		<b>Address: 0598H 0599H</b>
Default:	0	Control mode:	All
Unit:	Pulse unit of capture source	Setting range:	-1073741824 to +1073741823
Format:	DEC	Data size:	32-bit

Settings:

If the position reset function is enabled (P5.039.X [Bit 1] = 1), after the first position data is captured, the servo resets the position of the first point, and the position of the reset point is defined by this parameter.

<b>P5.077</b>	<b>E-Cam: position for synchronous Capture axis</b>		<b>Address: 059AH 059BH</b>
Default:	0	Control mode:	PR
Unit:	Pulse unit of master axis	Setting range:	-2147483648 to +2147483647
Format:	DEC	Data size:	32-bit

## Settings:

This parameter indicates the position for the synchronous Capture axis, which can be used as the command source for the E-Cam master axis (P5.088.Y = 5). When Capture operates every two times, the servo calculates the error between the moving distance of this axis and the set interval between each synchronous Capture action (P5.078).

Note: monitor the moving pulse amount between two capturing actions with the monitoring variable 081 (51h).

<b>P5.078</b>	<b>E-Cam: interval between each synchronous Capture action</b>		<b>Address: 059CH 059DH</b>
Default:	100	Control mode:	PR
Unit:	Pulse unit of master axis	Setting range:	10 to 100000000
Format:	DEC	Data size:	32-bit

## Settings:

Sets the moving pulse amount of the synchronous Capture axis between two capturing actions. The new value can only be written to the parameter when Capture is not in operation (P5.039.X [Bit 0] = 0).

<b>P5.079</b>	<b>E-Cam: pulse error for synchronous Capture axis</b>		<b>Address: 059EH 059FH</b>
Default:	0	Control mode:	PR
Unit:	Pulse unit of master axis	Setting range:	-2147483648 to +2147483647
Format:	DEC	Data size:	32-bit

## Settings:

When the synchronous Capture axis is operating, the pulse error should be 0. Each time when capturing data, the servo corrects the position error at the same time and this parameter updates once. It operates as follows:

$P5.079 = \text{incremental pulse amount between two capturing actions (monitoring variable 51h) minus interval pulse number between each synchronous Capture action (P5.078)}$ .

You can also write the offset of the synchronous axis to this parameter. When the synchronous Capture axis is the master axis for the rotary shear, modifying this parameter can shift the cutting position to the left or right. You can also use P1.016 (Error offset compensation for synchronous Capture axis) to achieve this effect.

Note: monitor the pulse error for synchronous Capture axis with the monitoring variable 084 (54h).



8

<b>P5.080</b>	<b>E-Cam: maximum correction rate for synchronous Capture axis</b>		<b>Address: 05A0H 05A1H</b>	
Default:	10	Control mode:	PR	
Unit:	%	Setting range:	0 to 90	
Format:	DEC	Data size:	16-bit	

Settings:

This parameter limits the correction rate (%) of the synchronous Capture axis.

Correction rate = Pulse number output by the synchronous axis / Pulse number input by the synchronous axis.

$$(100 - P5.080)\% < \text{Correction rate} < (100 + P5.080)\%$$

The bigger the correction rate, the faster the synchronous error falls to 0. However, the speed change is more drastic. The smaller the correction rate, the slower the synchronous error becomes 0. However, the speed change is smoother. In the rotary shear application, after the synchronous error of P5.079 is adjusted, the bigger the parameter value is, the faster the cutting position is corrected. However, the speed will not be synchronized.

<b>P5.081</b>	<b>E-Cam: start address for data array</b>		<b>Address: 05A2H 05A3H</b>	
Default:	100	Control mode:	PR	
Unit:	-	Setting range:	0 to (800 minus value set by P5.082)	
Format:	DEC	Data size:	16-bit	

Settings:

Specifies the address of the data array to save the first data in the E-Cam curve table. This parameter can be set at any time but will be effective only when the E-CAM system status changes from pre-engaged to engaged.

<b>P5.082</b>	<b>E-Cam: segment number (N)</b>		<b>Address: 05A4H 05A5H</b>	
Default:	5	Control mode:	PR	
Unit:	-	Setting range:	5 to 720	
Format:	DEC	Data size:	16-bit	

Settings:

Indicates that the E-Cam curve is divided into N segments, and the table includes N+1 data. This parameter is only writable when E-Cam stops (P5.088.X [Bit 0] = 0). Its range must be smaller than or equal to the value of P5.010 minus P5.081, and the value of P5.082 x P5.084 must be smaller than or equal to 2147483647.

P5.083	E-Cam: master gear ratio setting - cycle number (M)		Address: 05A6H 05A7H
Default:	1	Control mode:	PR
Unit:	-	Setting range:	1 to 32767
Format:	DEC	Data size:	16-bit

## Settings:

When the slave axis receives the pulse number of the master axis defined by P5.084, E-Cam rotates the number of cycles defined by P5.083 (one cycle of E-Cam = rotate from 0° to 360°). This parameter is only writable when E-Cam stops (P5.088.X [Bit 0] = 0).

P5.084	E-Cam: master gear ratio setting - pulse number (P)		Address: 05A8H 05A9H
Default:	3600	Control mode:	PR
Unit:	-	Setting range:	10 to 1073741823
Format:	DEC	Data size:	32-bit

## Settings:

When the slave axis receives the pulse number of the master axis defined by P5.084, E-Cam rotates the number of cycles defined by P5.083 (one cycle of E-Cam = rotate from 0° to 360°). This parameter can be modified at any time. Its range must be greater than or equal to the value of P5.082 x P5.083, and the value of P5.082 x P5.084 must be smaller than or equal to 2147483647.

P5.085	E-Cam: engaged segment number		Address: 05AAH 05ABH
Default:	0	Control mode:	PR
Unit:	-	Setting range:	0 to (value set by P5.082 minus 1)
Format:	DEC	Data size:	16-bit

## Settings:

Sets the segment number in the curve table when E-Cam engages.

P5.086■	E-Cam: master axis position		Address: 05ACH 05ADH
Default:	0	Control mode:	PR
Unit:	Pulse unit of master axis	Setting range:	-2147483648 to +2147483647
Format:	DEC	Data size:	32-bit

## Settings:

Position counter of the E-Cam master axis. When E-Cam is in operation, this value increases continuously. This parameter is only writable when E-Cam stops (P5.088.X [Bit 0] = 0).

8

<b>P5.087</b>	<b>E-Cam: initial lead pulse before engaged</b>		<b>Address: 05AEH 05AFH</b>
Default:	0	Control mode:	PR
Unit:	Pulse unit of master axis	Setting range:	-1073741824 to +1073741823
Format:	DEC	Data size:	32-bit

Settings:

When the E-Cam engagement condition (P5.088.Z) is met, the pulse number from the master axis has to exceed the value of this parameter for the E-Cam to fully engage. This parameter can be written with the virtual master axis pulse function (refer to description of P2.077).

<b>P5.088■</b>	<b>E-Cam: activate E-Cam control</b>		<b>Address: 05B0H 05B1H</b>
Default:	0x00000000	Control mode:	PR
Unit:	-	Setting range:	0x00000000 - 0x206FF267
Format:	HEX	Data size:	32-bit

Settings:



BA	Auto execute the specified PR path	X	Activation setting of E-Cam function
C	Reserved	Y	Command source
D	E-Cam engagement status	Z	Engagement condition
-	-	U	Disengagement condition

Definitions are as follows:

- X: activation setting of E-Cam function

Bit	Function	Description
0	E-Cam activation	0: E-Cam is disabled. 1: E-Cam is enabled (relevant parameters cannot be modified once E-Cam is enabled).
1	Clutch engagement when servo is off	0: when the servo is stopped by alarm or because servo is off, the clutch disengages. 1: when the servo is stopped by alarm or because servo is off, the clutch remains engaged. When the servo switches to on again, E-Cam can operate directly. If E-Cam phase offset occurs, use macro command #D to let the E-Cam return to the correct position.
2	P5.019 effective time	0: modification to P5.019 is effective after next engagement. 1: modification to P5.019 is effective immediately.
3	Reserved	-

- Y: command source
  - 0: Capture axis
  - 1: CN5
  - 2: CN1 (pulse command)
  - 3: PR command

- 4: time axis (1 ms)
- 5: synchronous Capture axis (P5.077)
- 6: analog voltage command (unit: 1M pulse/s per 10V)

- Z: engagement condition

- 0: immediately
- 1: trigger DI.CAM
- 2: any position data is captured

- U: disengagement condition (+ indicates multiple conditions, but 2, 4, and 6 cannot be selected at the same time)

U	Clutch disengagement condition	Status after disengaged
0	0: remains engaged.	-
1	1: disengages when DI.CAM (DI: 0x36) is off.	0: stop
2	2: disengages when master axis pulse number reaches the setting value of P5.089, and slave axis stops immediately.	0: stop
3	1 + 2: disengages when DI.CAM (DI: 0x36) is off or when master axis pulse number reaches the setting value of P5.089, and slave axis stops immediately.	0: stop
4	4: disengages when master axis pulse number reaches the setting value of P5.089 and enters the cyclic mode. When the pre-engaged pulse number for each cycle (P5.092) is reached, the clutch re-engages.	2: pre-engage
5	1 + 4: E-Cam enters the cyclic mode, but the clutch disengages when DI.CAM (DI: 0x36) is off.	0 or 2: pre-engage or stop
6	6: disengages when master axis pulse number reaches the setting value of P5.089, and slave axis decelerates to stop.	0: stop
7	1 + 6: disengages when DI.CAM (DI: 0x36) is off or when master axis pulse number reaches the setting value of P5.089, and slave axis decelerates to stop.	0: stop
8	8: set other disengagement conditions first, and the E-Cam function is disabled after the clutch disengages.	-
9	1 + 8: disengages when DI.CAM (DI: 0x36) is off and the E-Cam function is disabled.	0: stop and disable E-Cam.
A	2 + 8: disengages when master axis pulse number reaches the setting value of P5.089, slave axis stops immediately, and the E-Cam function is disabled.	0: stop and disable E-Cam
B	1 + 2 + 8: disengages when DI.CAM (DI: 0x36) is off or when master axis pulse number reaches the setting value of P5.089, slave axis stops immediately, and the E-Cam function is disabled.	0: stop and disable E-Cam
C	4 + 8 (special function): eases the speed vibration when the clutch returns to the pre-engaged condition. This is generally applied when the pre-engaged pulse number for each cycle (P5.092) is 0 and the pulse number of disengaging time equals master gear ratio (P5.089 = P5.084).	2: pre-engage
D	1 + 4 + 8: disengages when DI.CAM (DI: 0x36) is off, otherwise operates according to the condition of P5.088.U = C.	0 or 2: stop and disable E-Cam or pre-engage
E	6 + 8: disengages when master axis pulse number reaches the setting value of P5.089, slave axis decelerates to stop, and the E-Cam function is disabled.	0: stop and disable E-Cam.
F	1 + 6 + 8: disengages when DI.CAM (DI: 0x36) is off or when master axis pulse number reaches the setting value of P5.089, slave axis decelerates to stop, and the E-Cam function is disabled.	0: stop and disable E-Cam.

8

- BA: auto execute the specified PR path  
Set the PR path number for auto execution when the disengagement condition (P5.088.U = 2, 4, 6) is met. Use hexadecimal notation to specify PR#1 - 99 (01 - 63h) and 00 indicates not to continue with a PR command.
- D: E-Cam engagement status (read-only)  
0: stop  
1: engaged  
2: pre-engaged

<b>P5.089</b>	<b>E-Cam: pulse number upon disengagement</b>		<b>Address: 05B2H 05B3H</b>
Default:	0	Control mode:	PR
Unit:	Pulse unit of master axis	Setting range:	-1073741824 to +1073741823
Format:	DEC	Data size:	32-bit

Settings:

When the pulse number of the master axis reaches the value set by P5.089, the clutch disengages based on the disengagement condition setting (P5.088.U).

<b>P5.090</b>	<b>E-Cam: DO.CAM_AREA1 rising-edge phase</b>		<b>Address: 05B4H 05B5H</b>
Default:	270	Control mode:	PR
Unit:	Degree	Setting range:	0 to 360
Format:	DEC	Data size:	16-bit

Settings:

See the correlation between DO.CAM\_AREA1 (DO: 0x18) and the parameters in the following figure. When E-Cam is not in the engaged state, this signal is always off.

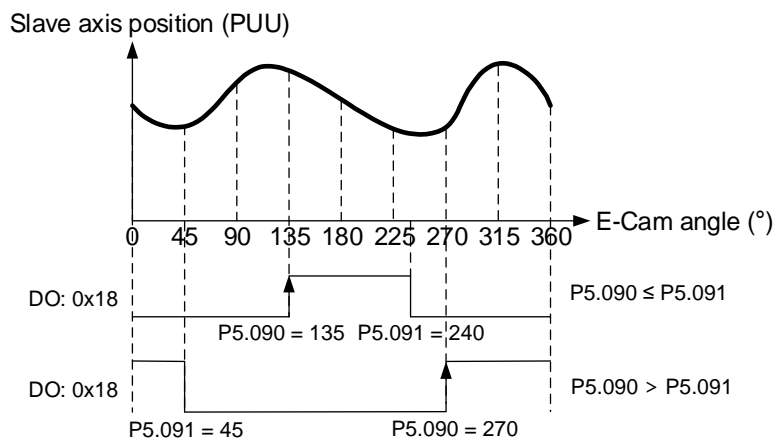

<b>P5.091</b>	<b>E-Cam: DO.CAM_AREA1 falling-edge phase</b>		<b>Address: 05B6H 05B7H</b>
Default:	360	Control mode:	PR
Unit:	Degree	Setting range:	0 to 360
Format:	DEC	Data size:	16-bit

Settings:

Refer to P5.090 for the correlation between DO.CAM\_AREA1 and the parameters.

<b>P5.092</b>	<b>E-Cam: pre-engaged pulse number for each cycle</b>		<b>Address: 05B8H 05B9H</b>
Default:	0	Control mode:	PR
Unit:	Pulse unit of master axis	Setting range:	-2147483648 to +2147483647
Format:	DEC	Data size:	32-bit

Settings:

This parameter goes with the selection of P5.088.U = 4 (E-Cam disengages and enters the cyclic mode). After the E-Cam system is not in the engaged status, the pre-engaged pulse number is determined by this parameter. The pulse number from the master axis has to exceed the value of this parameter for the E-Cam system to enter the engaged status.

<b>P5.093</b>	<b>Motion control macro command: command parameter #4</b>		<b>Address: 05BAH 05BBH</b>
Default:	0x00000000	Control mode:	All
Unit:	-	Setting range:	0x00000000 - 0xFFFFFFFF
Format:	HEX	Data size:	32-bit

Settings:

Before issuing the macro command, set the relevant parameters in advance. The function of the parameter is determined by the command code of the macro command. Not every macro command requires this parameter.

<b>P5.094</b>	<b>Motion control macro command: command parameter #3</b>		<b>Address: 05BCH 05BDH</b>
Default:	0	Control mode:	All
Unit:	-	Setting range:	-2147483648 to +2147483647
Format:	DEC	Data size:	32-bit

Settings:

Before issuing the macro command, set the relevant parameters in advance. The function of the parameter is determined by the command code of the macro command. Not every macro command requires this parameter.

8

<b>P5.095</b>	<b>Motion control macro command: command parameter #2</b>		<b>Address: 05BEH 05BFH</b>
Default:	0	Control mode:	All
Unit:	-	Setting range:	-2147483648 to +2147483647
Format:	DEC	Data size:	32-bit

## Settings:

Before issuing the macro command, set the relevant parameters in advance. The function of the parameter is determined by the command code of the macro command. Not every macro command requires this parameter.

<b>P5.096</b>	<b>Motion control macro command: command parameter #1</b>		<b>Address: 05C0H 05C1H</b>
Default:	0	Control mode:	All
Unit:	-	Setting range:	-2147483648 to +2147483647
Format:	DEC	Data size:	32-bit

## Settings:

Before issuing the macro command, set the relevant parameters in advance. The function of the parameter is determined by the command code of the macro command. Not every macro command requires this parameter.

<b>P5.097■</b>	<b>Motion control macro command: issue command / read execution result</b>		<b>Address: 05C2H 05C3H</b>
Default:	0x0000	Control mode:	All
Unit:	-	Setting range:	0x0000 - 0x099F
Format:	HEX	Data size:	16-bit

## Settings:

Write to this parameter to issue a macro command; read this parameter to examine the execution result of a macro command.

When you set the command code 0x0003 to this parameter, 0x1003 is returned if successful; and 0xF03X if unsuccessful (depending on the command description). If you issue a command that is not supported, the error code 0xF001 is returned.

The command codes are listed in the following tables:

Command code 0x0003	<p align="center"><b>Parameter and data array protection: password setting, protection activation</b></p> <p>This function can only be executed prior to activating the parameter protection function. When the protection function is activated, the failure code is returned if this function is executed repeatedly.</p>																
Macro parameter	<p>P5.093 = parameter write protection 0: disabled 1: enabled</p> <p>P5.094 = read protection range of parameter and data array (-1 to 8) -1: parameter groups 5, 6, 7 and data array are readable 0: parameter groups 5, 6, 7 and data array are unreadable 1: parameter groups 5, 6, 7 and data array #100 - 799 are unreadable 2: parameter groups 5, 6, 7 and data array #200 - 799 are unreadable 3: parameter groups 5, 6, 7 and data array #300 - 799 are unreadable 4: parameter groups 5, 6, 7 and data array #400 - 799 are unreadable 5: parameter groups 5, 6, 7 and data array #500 - 799 are unreadable 6: parameter groups 5, 6, 7 and data array #600 - 799 are unreadable 7: parameter groups 5, 6, 7 are unreadable, but data array is readable 8: parameter groups 1 - 7 are unreadable</p> <p>P5.095 = set new password (1 - 16777215) P5.096 = confirm new password (1 - 16777215)</p>																
Read the return value of P5.097 after executing the macro	<table border="1"> <tbody> <tr> <td align="center" colspan="2">Success code</td> </tr> <tr> <td align="center" colspan="2">0x1003</td> </tr> <tr> <td align="center" colspan="2">Failure code</td> </tr> <tr> <td>0xF031:</td> <td>protection function is activated and cannot be set repeatedly</td> </tr> <tr> <td>0xF032:</td> <td>wrong password setting; P5.095 does not equal P5.096</td> </tr> <tr> <td>0xF033:</td> <td>password value exceeds the allowable range (1 - 16777215)</td> </tr> <tr> <td>0xF034:</td> <td>protection range P5.094 exceeds the allowable range (-1 to 8)</td> </tr> <tr> <td>0xF035:</td> <td>protection level P5.093 exceeds the allowable range (0 - 1)</td> </tr> </tbody> </table>	Success code		0x1003		Failure code		0xF031:	protection function is activated and cannot be set repeatedly	0xF032:	wrong password setting; P5.095 does not equal P5.096	0xF033:	password value exceeds the allowable range (1 - 16777215)	0xF034:	protection range P5.094 exceeds the allowable range (-1 to 8)	0xF035:	protection level P5.093 exceeds the allowable range (0 - 1)
Success code																	
0x1003																	
Failure code																	
0xF031:	protection function is activated and cannot be set repeatedly																
0xF032:	wrong password setting; P5.095 does not equal P5.096																
0xF033:	password value exceeds the allowable range (1 - 16777215)																
0xF034:	protection range P5.094 exceeds the allowable range (-1 to 8)																
0xF035:	protection level P5.093 exceeds the allowable range (0 - 1)																
Command code 0x0004	<p align="center"><b>Parameter and data array protection: unlock protection</b></p> <p>This function can only be executed when the protection function is activated. When the protection function is unlocked, the failure code is returned if this function is executed repeatedly. If the wrong password is entered, failure code 0xE<sub>nnn</sub> is returned. nnn indicates the remaining attempts to enter the password. The number decrements by 1 after each failed attempt. When the number displays 0, it indicates the maximum number of failed password attempts has been reached and this functions is disabled. You can only reset all parameters (P2.008 = 10) to unlock.</p>																
Macro parameter	P5.096 = enter password (1 - 16777215)																
Read the return value of P5.097 after executing the macro	<table border="1"> <tbody> <tr> <td align="center" colspan="2">Success code</td> </tr> <tr> <td align="center" colspan="2">0x1004</td> </tr> <tr> <td align="center" colspan="2">Failure code</td> </tr> <tr> <td>0xF041:</td> <td>protection function is unlocked and cannot be unlocked repeatedly</td> </tr> <tr> <td>0xF043:</td> <td>password value exceeds the allowable range (1 - 16777215)</td> </tr> <tr> <td>0xF044:</td> <td>the maximum number of failed password attempts has been reached and the function is disabled. You can only unlock by resetting the parameters (P2.008 = 10), but this also resets all parameters to the default values.</td> </tr> <tr> <td>0xE<sub>nnn</sub>:</td> <td>incorrect password setting; failed to unlock nnn: remaining attempts to enter the password. The number decrements by 1 after each failed attempt. When the number displays 0, the function is disabled and does not allow further attempts.</td> </tr> </tbody> </table>	Success code		0x1004		Failure code		0xF041:	protection function is unlocked and cannot be unlocked repeatedly	0xF043:	password value exceeds the allowable range (1 - 16777215)	0xF044:	the maximum number of failed password attempts has been reached and the function is disabled. You can only unlock by resetting the parameters (P2.008 = 10), but this also resets all parameters to the default values.	0xE <sub>nnn</sub> :	incorrect password setting; failed to unlock nnn: remaining attempts to enter the password. The number decrements by 1 after each failed attempt. When the number displays 0, the function is disabled and does not allow further attempts.		
Success code																	
0x1004																	
Failure code																	
0xF041:	protection function is unlocked and cannot be unlocked repeatedly																
0xF043:	password value exceeds the allowable range (1 - 16777215)																
0xF044:	the maximum number of failed password attempts has been reached and the function is disabled. You can only unlock by resetting the parameters (P2.008 = 10), but this also resets all parameters to the default values.																
0xE <sub>nnn</sub> :	incorrect password setting; failed to unlock nnn: remaining attempts to enter the password. The number decrements by 1 after each failed attempt. When the number displays 0, the function is disabled and does not allow further attempts.																



8

<b>E-Cam disengages after engaged for one cycle</b>	
Command code 0x0005	Set the pulse number of master gear ratio (P5.084) and pulse number upon disengagement (P5.089) as the same value. With the disengagement condition (P5.088.U = 2, 4, 6) and the cycle number of master gear ratio as 1 (P5.083 = 1), E-Cam disengages after being engaged for one cycle.
Macro parameter	P5.095 = pulse number of master gear ratio
Read the return value of P5.097 after executing the macro	Success code
	0x1005
	Failure code
	0xF005: pulse number of master gear ratio (P5.084) exceeds the range. $(P5.082 \times P5.083 \leq P5.084 \leq \frac{2^{32}}{P5.082})$
<b>Create E-Cam table: rotary shear (fixed synchronous speed zone)</b>	
Command code 0x0006	This macro automatically calculates the data for the E-Cam table according to the macro parameters and stores them in the data array specified by P5.081. After this macro is executed, if the macro parameters have been modified, the E-Cam table must be recreated and you must execute this macro again. Data in the E-Cam table is changed after this macro is executed; thus, do not execute this macro when E-Cam is in the engaged status. After this macro is executed, the E-Cam table is not stored in EEPROM automatically.  In E-Cam applications, parameters (such as P5.083 and P5.084) that are irrelevant to this macro are not listed here. Set the parameters according to the actual application. Refer to Section 7.3.7 Rotary shear.
General parameter	P5.081 (Start address for data array) P5.082 (E-Cam segment number) = 7; this macro is fixed to 7 segments, 8 points P1.044, P1.045 (E-Gear ratio)
Macro parameter	P5.094 = A (number of teeth on the motor) x C (cutting count) P5.095 = B (number of teeth on the cutter) P5.096 = 1000000 x R x V R (cutting length ratio, range 0.07 to 2.5) = L (target cutting length) / ℓ (perimeter of cutter) V (speed compensation, range -20% to 20%) = cutting speed / feeding speed V = 1.0: during cutting, the speed of cutter is the same as the feeding speed V = 1.1: during cutting, the speed of cutter increases 10% V = 0.9: during cutting, the speed of cutter decreases 10%, and so on
Read the return value of P5.097 after executing the macro	Success code
	0x1006
	Failure code
	0xF061: the clutch is engaged, so the E-Cam table cannot be created
	0xF062: data of P5.094 exceeds the range (1 - 65535)
	0xF063: data of P5.095 exceeds the range (1 - 65535)
	0xF064: data of P5.096 exceeds the range (300000 - 2500000)
	0xF065: P5.081 start address for data array exceeds the array length
0xF066: P5.082 E-Cam segment number must be set to 7	
0xF067: E-Gear ratio set by P1.044 and P1.045 is too high. Decrease the value of P1.044 and P1.045 but maintain the same proportions. For example: adjust 167772160 : 1000000 to 16777216 : 100000	

<b>Create E-Cam table: rotary shear (adjustable synchronous speed zone)</b>														
Command code 0x0007	<p>This macro automatically calculates the data for the E-Cam table according to the macro parameters and stores them in the data array specified by P5.081. After this macro is executed, if the macro parameters have been modified, the E-Cam table must be recreated and you must execute this macro again. Data in the E-Cam table is changed after this macro is executed; thus, do not execute this macro when E-Cam is in the engaged status. After this macro is executed, the E-Cam table is not stored in EEPROM automatically.</p> <p>In E-Cam applications, parameters (such as P5.083 and P5.084) that are irrelevant to this macro are not listed here. Set the parameters according to the actual application. Refer to Section 7.3.7 Rotary shear.</p>													
General parameter	P5.081 (Start address for data array) P5.082 (E-Cam segment number) = N (range 30 - 72) P1.044, P1.045 (E-Gear ratio)													
Macro parameter	P5.093.H (high word)(Hex) = S (S-curve level, range 1 - 4) P5.093.L (low word)(Hex) = W (degree of waiting zone, range -1 to 170 degrees) Supplementary formula: $W' = 180 + 360/N - 360/R + Y/2$ When P5.093.L < W', E-Cam table is in error (failure code 0xF07A) When P5.093.L = W', initial speed is 0 in E-Cam table When P5.093.L > W', initial speed > 0 in E-Cam table, and W must be set to -1 P5.094 = Y (degree of synchronous speed zone, range 0 to 330 degrees) P5.095.H (high word) = A (number of teeth on the motor) x C (cutting count) P5.095.L (low word) = B (number of teeth on the cutter) P5.096 = 1000000 x R x V (range 1.88 > R x V) R (cutting length ratio) = L (target cutting length) / $\ell$ (perimeter of cutter) V (speed compensation, range -20% to 20%) = cutting speed / feeding speed V = 1.0: during cutting, the speed of cutter is the same as the feeding speed V = 1.1: during cutting, the speed of cutter increases 10% V = 0.9: during cutting, the speed of cutter decreases 10%, and so on													
Read the return value of P5.097 after executing the macro	<table border="1" style="width: 100%; border-collapse: collapse;"> <thead> <tr> <th style="text-align: center;">Success code</th> </tr> </thead> <tbody> <tr> <td style="text-align: center;">0x1007</td> </tr> <tr> <th style="text-align: center;">Failure code</th> </tr> <tr> <td>0xF071: the clutch is engaged, so the E-Cam table cannot be created</td> </tr> <tr> <td>0xF072: P5.094 degree of synchronous speed zone exceeds the range (0 - 330)</td> </tr> <tr> <td>0xF073: S-curve level of P5.093.H exceeds the range (1 - 4)</td> </tr> <tr> <td>0xF074: P5.093.L degree of waiting zone exceeds the range (-1 to 170)</td> </tr> <tr> <td>0xF075: data of P5.096 exceeds the range (50000 - 5000000)</td> </tr> <tr> <td>0xF076: P5.082 E-Cam segment number exceeds the range (30 - 72)</td> </tr> <tr> <td>0xF077: P5.081 start address for data array exceeds the array length</td> </tr> <tr> <td>0xF078: E-Gear ratio set by P1.044 and P1.045 is too high. Decrease the value of P1.044 and P1.045 but maintain the same proportions. For example: adjust 167772160 : 1000000 to 16777216 : 100000</td> </tr> <tr> <td>0xF079: degree of acceleration zone is too small. Decrease the value for the waiting zone, synchronous speed zone, or S-curve level.</td> </tr> <tr> <td>0xF07A: waiting zone &lt; minimum waiting zone. Increase the value for the waiting zone or decrease the value for the synchronous speed zone.</td> </tr> </tbody> </table>	Success code	0x1007	Failure code	0xF071: the clutch is engaged, so the E-Cam table cannot be created	0xF072: P5.094 degree of synchronous speed zone exceeds the range (0 - 330)	0xF073: S-curve level of P5.093.H exceeds the range (1 - 4)	0xF074: P5.093.L degree of waiting zone exceeds the range (-1 to 170)	0xF075: data of P5.096 exceeds the range (50000 - 5000000)	0xF076: P5.082 E-Cam segment number exceeds the range (30 - 72)	0xF077: P5.081 start address for data array exceeds the array length	0xF078: E-Gear ratio set by P1.044 and P1.045 is too high. Decrease the value of P1.044 and P1.045 but maintain the same proportions. For example: adjust 167772160 : 1000000 to 16777216 : 100000	0xF079: degree of acceleration zone is too small. Decrease the value for the waiting zone, synchronous speed zone, or S-curve level.	0xF07A: waiting zone < minimum waiting zone. Increase the value for the waiting zone or decrease the value for the synchronous speed zone.
Success code														
0x1007														
Failure code														
0xF071: the clutch is engaged, so the E-Cam table cannot be created														
0xF072: P5.094 degree of synchronous speed zone exceeds the range (0 - 330)														
0xF073: S-curve level of P5.093.H exceeds the range (1 - 4)														
0xF074: P5.093.L degree of waiting zone exceeds the range (-1 to 170)														
0xF075: data of P5.096 exceeds the range (50000 - 5000000)														
0xF076: P5.082 E-Cam segment number exceeds the range (30 - 72)														
0xF077: P5.081 start address for data array exceeds the array length														
0xF078: E-Gear ratio set by P1.044 and P1.045 is too high. Decrease the value of P1.044 and P1.045 but maintain the same proportions. For example: adjust 167772160 : 1000000 to 16777216 : 100000														
0xF079: degree of acceleration zone is too small. Decrease the value for the waiting zone, synchronous speed zone, or S-curve level.														
0xF07A: waiting zone < minimum waiting zone. Increase the value for the waiting zone or decrease the value for the synchronous speed zone.														

<b>E-Cam curve scaling (P5.019) is effective immediately</b>	
Command code 0x0008	<p>This macro can be executed when the clutch is engaged, and the E-Cam scaling (P5.019) becomes effective immediately.</p> <p>If it is necessary to change the E-Cam scaling immediately in the application, set P5.088.X [Bit 2] to 1 or execute this macro. Otherwise, the E-Cam scaling is loaded into the system by P5.019 at the point only when E-Cam engages (see the following transition 3). The scaling cannot be changed in the engaged condition.</p>
Macro parameter	N/A
Read the return value of P5.097 after executing the macro	Success code
	0x1008
	Failure code
	N/A

<b>Change engaged position: rotates in forward direction until disengagement condition is met</b>	
Command code 0x000C	<p>This macro command can change the E-Cam position immediately even when the clutch is engaged. It automatically calculates the remaining engaged length so that E-Cam disengages according to the disengagement condition (P5.088.U) after the E-Cam rotates one cycle (360°) in the forward direction.</p> <p>E-Cam disengages when an alarm occurs or power supply is cut off. If you want E-Cam to re-engage at the last disengaged position and continue its remaining cycle, it is recommended that you record the master axis position of the last disengagement and then execute this macro command. Note that when E-Cam is disengaged, the servo position might shift slightly, causing position error when E-Cam re-engages. It is recommended that you execute the macro command before operating the master axis. For setting details, refer to Section 7.3.9 Macro.</p> <p>When E-Cam rotates one cycle, pulse number of master axis: (P5.084 / P5.083)</p>
Macro parameter	<p>P5.093 (Hex) = specifies master axis engaged position; unit: pulse number of master axis</p> <p>Note: monitoring variable 062 (3Eh) displays the current position of the master axis.</p>
Read the return value of P5.097 after executing the macro	Success code
	0x100C
	Failure code
	0xF0C1: when this macro command is executed, E-Cam is not in the engaged status
	0xF0C2: engaged position specified by P5.093 exceeds the range (the value cannot be less than 0)
0xF0C3: engaged position specified by P5.093 exceeds the range (the value has to be less than the value of (P5.084 / P5.083))	

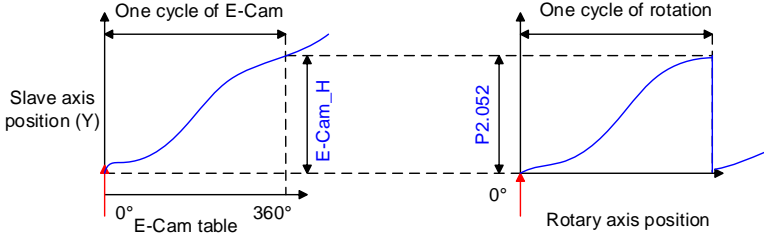
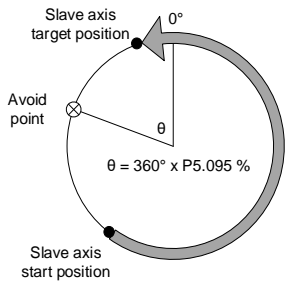
<p>Command code 0x000D</p>	<p align="center"><b>Calculate the error between the current position of the slave axis and rotary axis position for PR positioning</b></p> <p>When the clutch is engaged and the motor is stopped due to Servo Off or an alarm, position error occurs between the actual position and the E-Cam position. After the servo switches to on again, use this macro command to automatically calculate the displacement value and write the value to the specified PR for incremental positioning. When this PR command is executed, the slave axis returns to the corresponding position of the master axis position according to the positive / negative type and reverse limit. For setting details, refer to Section 7.3.9 Macro.</p> <p>When using this macro command:</p> <ol style="list-style-type: none"> <li>1. Set P5.088.X [Bit 1] to 1 to keep the clutch engaged when Servo Off.</li> <li>2. Have the height of rotary axis position and E-Cam position be the same: P2.052 = ECAM_H (moving distance when slave axis operates one cycle)</li> <li>3. Set the E-Cam curve scaling (P5.019) to 1.0 times.</li> <li>4. Have the 0 degree positions in the E-Cam table point to the origin of the rotary axis position when E-Cam is engaged for the first time. You can achieve this alignment by executing homing.</li> <li>5. You can only use this macro command for a periodic cycle which always starts from the same position.</li> </ol>  <p>Note:</p> <ol style="list-style-type: none"> <li>1. ECAM_H (moving distance when slave axis operates one cycle) = E-Cam table last point minus E-Cam table first point.</li> <li>2. Rotary axis position = remainder of (absolute position / P2.052). Monitoring variable 091 displays the current rotary axis position (PUU).</li> <li>3. Use PR command via incremental positioning control.</li> </ol>
<p>Macro parameter</p>	<p>P5.093 (Hex) = DCBA UZYX              YX: PR number (0x01 - 0x63); invalid when value is 0              UZ = 00              BA: positive / negative type (P5.095). 0 (avoid point); 1 (allowable forward rate)              DC: inhibit reverse rotation. 0 (invalid); 1 (inhibit reverse rotation)              P5.095 = avoid point cycle 0 - 100(%) or allowable forward rate 0 - 100(%)</p> 

8

	<p> </p> <p> <b>E-Cam current position</b>          Maximum forward rotation limit. Counterclockwise direction is forward direction in the figure     </p> <p> <b>Target position is within this range; onward trip is in forward direction</b>  <b>Target position is within this range; onward trip is in reverse direction</b> </p> <p>         Allowable forward rate = 0%; reverse direction only for onward trip     </p> <p>         Allowable forward rate = 75%; onward maximum path is +270°     </p> <p>         Allowable forward rate = 25%; onward maximum path is +90°     </p> <p>         Allowable forward rate = 100%; forward direction only for onward trip     </p> <p>         Allowable forward rate = 50%; onward maximum path is +180°     </p>
<p>Read the return value of P5.097 after executing the macro</p>	<p>Success code</p>
	<p>0x100D</p>
	<p>Failure code</p>
	<p>0xF0D1: when this macro command is executed, E-Cam is not in the engaged status</p>
	<p>0xF0D2: PR number specified by P5.093.YX exceeds the range (0x01 - 0x63)</p>
	<p>0xF0D3: P5.095 avoid point or allowable forward rate exceeds the range (0 - 100%)</p>
	<p>0xF0D5: position correction value does not exist. This macro command might be triggered twice.</p>
	<p>0xF0D6: E-Cam did not remain engaged when servo is off, so when servo switches to on again, E-Cam is not engaged</p>
	<p>0xF0D7: slave axis moving distance does not equal the total rotary axis moving distance (ECAM_H ≠ P2.052)</p>
	<p>0xF0D8: E-Cam curve scaling does not equal 1 (P5.019 ≠ 1)</p>
	<p>0xF0D9: P5.093.BA positive / negative type setting exceeds the range (00 - 01)</p>
<p>0xF0DA: P5.093.DC reverse inhibit setting exceeds the range (00 - 01)</p>	
<p>0xF0DB: the reverse inhibit function has failed. Do not use macro commands #D and #10 consecutively.</p>	

<b>E-Cam displacement value for PR positioning</b>													
<p>Command code 0x000E</p>	<p>When the clutch is engaged, set the E-Cam engaging position with this macro command and calculate the displacement value for the slave axis alignment, and then write the displacement value to the specified PR for incremental positioning. Trigger this PR when needed to move the slave axis to the corresponding target position.</p> <p>During E-Cam operation, if you want to quickly align the E-Cam position with the mechanical referral point, you can use the sensor to trigger the DI to execute this macro command. For setting details, refer to Section 7.3.9 Macro.</p> <p style="text-align: center;">When E-Cam rotates one cycle, pulse number of master axis: (P5.084 / P5.083)</p>												
<p>Macro parameter</p>	<p>P5.093 = DCBA UZYX (HEX)                      YX: PR number (0x01 - 0x63); invalid when value is 0                      UZ: maximum allowable alignment correction rate (0x00 - 0x64%)  <math display="block">\left  \text{Alignment target position} - \text{Current position} \right  / \text{Pulse number of master axis when E-Cam rotates one cycle}</math>                      A: PR triggering method. 0 (manual trigger); 1 (immediate automatic trigger)                      B: position of the mark. 0 (on non-compensated motion axis); 1 (on compensated motion axis)                      C: DI channel. 0 (general DI triggering event); 1 (high-speed DI7 with Capture)                      D = 0                      P5.094 = DI time delay compensation (-25000 to +25000 μs)                      P5.095 = Allowable forward rate (0 - 100%) (Refer to macro command #D for the setting)                      P5.096 = Alignment target position; unit: pulse number of master axis (0 to (P5.084 / P5.083) -1)                      Note: monitoring variable 062 (3Eh) displays the current position of the master axis.</p>												
<p>Read the return value of P5.097 after executing the macro</p>	<table border="1" style="width: 100%; border-collapse: collapse;"> <tr> <td style="text-align: center;">Success code</td> </tr> <tr> <td style="text-align: center;">0x100E</td> </tr> <tr> <td style="text-align: center;">Failure code</td> </tr> <tr> <td>0xF0E1: when this macro command is executed, E-Cam is not in the engaged status</td> </tr> <tr> <td>0xF0E2: PR number specified by P5.093.YX exceeds the range (0x01 - 0x63)</td> </tr> <tr> <td>0xF0E3: P5.093.UZ maximum correction rate exceeds the range (0 - 0x64%)</td> </tr> <tr> <td>0xF0E4: P5.094 DI delay time compensation exceeds the range (-25000 to +25000 μs)</td> </tr> <tr> <td>0xF0E5: P5.095 allowable forward rate exceeds the range (0 - 100%)</td> </tr> <tr> <td>0xF0E6: P5.096 alignment target position exceeds the range (0 to (P5.084 / P5.083) -1)</td> </tr> <tr> <td>0xF0E7: P5.093 setting value exceeds the range (0x0000 - 0x0111)</td> </tr> <tr> <td>0xF0E8: when using DI7 with Capture triggering (P5.093.C = 1), set the master axis pulse source to the Capture axis (P5.088.Y = 0)</td> </tr> <tr> <td>0xF0E9: when using DI7 with Capture triggering (P5.093.C = 1), execute PR#50 (P5.039.X [Bit 3] = 1) for compensation after the last data is captured</td> </tr> </table>	Success code	0x100E	Failure code	0xF0E1: when this macro command is executed, E-Cam is not in the engaged status	0xF0E2: PR number specified by P5.093.YX exceeds the range (0x01 - 0x63)	0xF0E3: P5.093.UZ maximum correction rate exceeds the range (0 - 0x64%)	0xF0E4: P5.094 DI delay time compensation exceeds the range (-25000 to +25000 μs)	0xF0E5: P5.095 allowable forward rate exceeds the range (0 - 100%)	0xF0E6: P5.096 alignment target position exceeds the range (0 to (P5.084 / P5.083) -1)	0xF0E7: P5.093 setting value exceeds the range (0x0000 - 0x0111)	0xF0E8: when using DI7 with Capture triggering (P5.093.C = 1), set the master axis pulse source to the Capture axis (P5.088.Y = 0)	0xF0E9: when using DI7 with Capture triggering (P5.093.C = 1), execute PR#50 (P5.039.X [Bit 3] = 1) for compensation after the last data is captured
Success code													
0x100E													
Failure code													
0xF0E1: when this macro command is executed, E-Cam is not in the engaged status													
0xF0E2: PR number specified by P5.093.YX exceeds the range (0x01 - 0x63)													
0xF0E3: P5.093.UZ maximum correction rate exceeds the range (0 - 0x64%)													
0xF0E4: P5.094 DI delay time compensation exceeds the range (-25000 to +25000 μs)													
0xF0E5: P5.095 allowable forward rate exceeds the range (0 - 100%)													
0xF0E6: P5.096 alignment target position exceeds the range (0 to (P5.084 / P5.083) -1)													
0xF0E7: P5.093 setting value exceeds the range (0x0000 - 0x0111)													
0xF0E8: when using DI7 with Capture triggering (P5.093.C = 1), set the master axis pulse source to the Capture axis (P5.088.Y = 0)													
0xF0E9: when using DI7 with Capture triggering (P5.093.C = 1), execute PR#50 (P5.039.X [Bit 3] = 1) for compensation after the last data is captured													

8

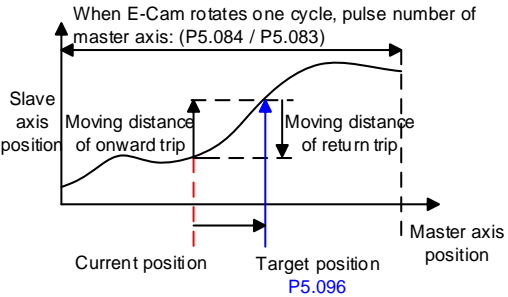
<p>Command code 0x000F</p>	<p align="center"><b>Calculate the moving distance between the current and target position of the slave axis for PR positioning</b></p> <p>When the clutch is engaged, this macro command calculates the moving distance between the current and target position of the slave axis and writes the value to the PR incremental position command.</p> <p>During E-Cam operation, if you want to move the slave axis to the specified position when the master axis stops but with the E-Cam in the engaged status, use this macro command to calculate the moving distance of the onward trip and save the value in the specified PR incremental position command. When the master axis resumes operation, use another PR incremental position command for the moving distance of the return trip, so E-Cam returns to the original position (moving distance of onward trip + moving distance of return trip = 0). For setting details, refer to Section 7.3.9 Macro.</p> 																
<p>Macro parameter</p>	<p>P5.093.L (low word)(Hex) = UZYX                  YX: PR number of onward trip (0x01 - 0x63); invalid when value is 0                  UZ: PR number of return trip (0x01 - 0x63); invalid when value is 0</p> <p>P5.093.H (high word)(Hex) = 0</p> <p>P5.095: allowable forward rate (0 - 100%) (Refer to macro command #D for the setting.)</p> <p>P5.096: target position; unit: pulse number of master axis (0 to (P5.084 / P5.083) -1)</p> <p>Note: monitoring variable 062 (3Eh) displays the current position of the master axis.</p>																
<p>Read the return value of P5.097 after executing the macro</p>	<table border="1"> <tr> <td align="center" colspan="2">Success code</td> </tr> <tr> <td align="center" colspan="2">0x100F</td> </tr> <tr> <td align="center" colspan="2">Failure code</td> </tr> <tr> <td>0xF0F1:</td> <td>when this macro command is executed, E-Cam is not in the engaged status</td> </tr> <tr> <td>0xF0F2:</td> <td>PR number of onward trip specified by P5.093.YX exceeds the range (0x01 - 0x63)</td> </tr> <tr> <td>0xF0F3:</td> <td>PR number of return trip specified by P5.093.UZ exceeds the range (0x01 - 0x63)</td> </tr> <tr> <td>0xF0F5:</td> <td>P5.095 allowable forward rate exceeds the range (0 - 100%)</td> </tr> <tr> <td>0xF0F6:</td> <td>P5.096 target position exceeds the range (0 to (P5.084 / P5.083) -1)</td> </tr> </table>	Success code		0x100F		Failure code		0xF0F1:	when this macro command is executed, E-Cam is not in the engaged status	0xF0F2:	PR number of onward trip specified by P5.093.YX exceeds the range (0x01 - 0x63)	0xF0F3:	PR number of return trip specified by P5.093.UZ exceeds the range (0x01 - 0x63)	0xF0F5:	P5.095 allowable forward rate exceeds the range (0 - 100%)	0xF0F6:	P5.096 target position exceeds the range (0 to (P5.084 / P5.083) -1)
Success code																	
0x100F																	
Failure code																	
0xF0F1:	when this macro command is executed, E-Cam is not in the engaged status																
0xF0F2:	PR number of onward trip specified by P5.093.YX exceeds the range (0x01 - 0x63)																
0xF0F3:	PR number of return trip specified by P5.093.UZ exceeds the range (0x01 - 0x63)																
0xF0F5:	P5.095 allowable forward rate exceeds the range (0 - 100%)																
0xF0F6:	P5.096 target position exceeds the range (0 to (P5.084 / P5.083) -1)																

Command code 0x0010	<b>Slave axis immediately pauses for one cycle</b>
	<p>After the clutch is engaged, this macro command can immediately pause the slave axis for one cycle regardless of the current E-Cam position. To use this macro command to pause the slave axis, the E-Cam curve must be in forward operation (including straight line). Use this macro command with P1.022.YX acceleration time limit and P1.022.U reverse inhibit to prevent mechanical vibration. For setting details, refer to Section 7.3.9 Macro.</p> <p>Note: this function is accumulative. If the command is triggered for N times consecutively, it pauses the E-Cam for N cycles. Note that the accumulated pause distance cannot exceed 2<sup>31</sup>, otherwise the macro command is invalid. When E-Cam resumes operation, the accumulated pause distance is cleared to 0.</p>
Macro parameter	P5.093 (Hex) = 0x00000000
Read the return value of P5.097 after executing the macro	Success code
	0x1010
	Failure code
	0xF101: when this macro command is executed, E-Cam is not in the engaged status
	0xF102: value of P5.093 exceeds the range; must be set to 0x00000000
	0xF103: slave axis must operate in the forward direction. Check the E-Cam curve and P5.019 E-Cam curve scaling
	0xF104: accumulated pause distance exceeds 2 <sup>31</sup> . Do not execute this macro command consecutively

<b>P5.098</b>	<b>PR number triggered by event rising-edge</b>	<b>Address: 05C4H 05C5H</b>
Default:	0x0000	Control mode: PR
Unit:	-	Setting range: 0x0000 - 0xDDDD
Format:	HEX	Data size: 16-bit

Settings:



X	The action when PR is EV1 rising-edge triggered	Z	The action when PR is EV3 rising-edge triggered
Y	The action when PR is EV2 rising-edge triggered	U	The action when PR is EV4 rising-edge triggered

- X: the action when EV1 is on
  - 0: no action
  - 1 - D: execute PR# 51 - 63
- Y: the action when EV2 is on
  - 0: no action
  - 1 - D: execute PR# 51 - 63



8

- Z: the action when EV3 is on
  - 0: no action
  - 1 - D: execute PR# 51 - 63
  
- U: the action when EV4 is on
  - 0: no action
  - 1 - D: execute PR# 51 - 63

<b>P5.099</b>	<b>PR number triggered by event falling-edge</b>		<b>Address: 05C6H 05C7H</b>
Default:	0x0000	Control mode:	PR
Unit:	-	Setting range:	0x0000 - 0xDDDD
Format:	HEX	Data size:	16-bit

Settings:



X	The action when PR is EV1 falling-edge triggered	Z	The action when PR is EV3 falling-edge triggered
Y	The action when PR is EV2 falling-edge triggered	U	The action when PR is EV4 falling-edge triggered

- X: the action when EV1 is off
  - 0: no action
  - 1 - D: execute PR# 51 - 63
  
- Y: the action when EV2 is off
  - 0: no action
  - 1 - D: execute PR# 51 - 63
  
- Z: the action when EV3 is off
  - 0: no action
  - 1 - D: execute PR# 51 - 63
  
- U: the action when EV4 is off
  - 0: no action
  - 1 - D: execute PR# 51 - 63

<b>P5.100■</b>	<b>Data array: window #3 for reading and writing</b>		<b>Address: 05C8H 05C9H</b>
Default:	0	Control mode:	All
Unit:	-	Setting range:	-2147483648 to +2147483647
Format:	DEC	Data size:	32-bit

Settings:

Window #3: when read or written by any method, the value set by P5.011 does not add 1.

Refer to Section 7.2.1 Data array for detailed instructions.

<b>P5.101■</b>	<b>Data array: window #4 for reading and writing</b>		<b>Address: 05CAH 05CBH</b>
Default:	0	Control mode:	All
Unit:	-	Setting range:	-2147483648 to +2147483647
Format:	DEC	Data size:	32-bit

Settings:

Window #4: when read or written by any method, the value set by P5.011 does not add 1.

Refer to Section 7.2.1 Data array for detailed instructions.

<b>P5.102■</b>	<b>Data array: window #5 for reading and writing</b>		<b>Address: 05CCH 05CDH</b>
Default:	0	Control mode:	All
Unit:	-	Setting range:	-2147483648 to +2147483647
Format:	DEC	Data size:	32-bit

Settings:

Window #5: when read or written by any method, the value set by P5.011 does not add 1.

Refer to Section 7.2.1 Data array for detailed instructions.

<b>P5.103■</b>	<b>Data array: window #6 for reading and writing</b>		<b>Address: 05CEH 05CFH</b>
Default:	0	Control mode:	All
Unit:	-	Setting range:	-2147483648 to +2147483647
Format:	DEC	Data size:	32-bit

Settings:

Window #6: when read or written by any method, the value set by P5.011 does not add 1.

Refer to Section 7.2.1 Data array for detailed instructions.

8

**P6.xxx PR parameters**

<b>P6.000</b>	<b>Homing definition</b>		<b>Address: 0600H 0601H</b>
Default:	0x00000000	Control mode:	PR
Unit:	-	Setting range:	0x00000000 - 0xFFFFFFFF6F
Format:	HEX	Data size:	32-bit

Settings:

Homing definition:



A	DEC2: deceleration time selection for second homing	YX	PATH: path type
B	DLY: select 0 - F for delay time	Z	ACC: select 0 - F for acceleration time
C	Reserved	U	DEC1: deceleration time selection for first homing
D	BOOT: whether to execute homing automatically when the drive is powered on	-	-

- YX: PATH: path type  
 0x00: Stop: the servo stops after homing is complete  
 0x01 - 0x63: Auto: the servo executes the specified path (Path 1 - Path 99) after homing is complete
- Z: ACC: select 0 - F for acceleration time  
 0 - F: correspond to P5.020 - P5.035
- U: DEC1: deceleration time selection for first homing  
 0 - F: correspond to P5.020 - P5.035
- A: DEC2: deceleration time selection for second homing  
 0 - F: correspond to P5.020 - P5.035
- B: DLY: select 0 - F for delay time  
 0 - F: correspond to P5.040 - P5.055
- D: BOOT: whether to execute homing automatically when the drive is powered on  
 0: do not execute homing  
 1: execute homing automatically (servo switches to on for the first time after power is applied)

Apart from the preceding definitions, the related settings for homing also include:

1. P5.004: homing methods.
2. P5.005 - P5.006: speed settings of searching for the origin.
3. P6.001: the origin definition (ORG\_DEF) is the position of the origin and may not be 0. This function is used as a traversal of the position system.

Note:

1. After finding the origin (sensor or Z), the servo has to decelerate to a stop. The stop position exceeds the origin by a short distance:

If returning to the origin is not needed, set PATH to 0x00.

If returning to the origin is needed, set PATH to a 0x01 - 0x63 and set the route as PABS = 0.

Example:

When P6.000 = 0x0001, the servo automatically executes Path 1 after homing is complete.

Set the route of Path 1 (setting P6.002 & P6.003) as moving to the absolute position of 0.

2. If the origin is found (sensor or Z) and you want the servo to move an offset S and define the position after moving as P, then set PATH = non-zero and set ORG\_DEF = P - S, and this absolute Position command = P.

P6.001	Origin definition		Address: 0602H 0603H
Default:	0	Control mode:	PR
Unit:	-	Setting range:	-2147483648 to +2147483647
Format:	DEC	Data size:	32-bit

Settings:

Origin definition.

P6.002	PATH 1 definition		Address: 0604H 0605H
Default:	0x00000000	Control mode:	PR
Unit:	-	Setting range:	0x00000000 - 0xFFFFFFFF
Format:	HEX	Data size:	32-bit

Settings:

Format of this parameter: (High word h) DCBA : (Low word L) UZYX



A	SPD, Target speed <sup>Note</sup>	X	TYPE, Path type
B	DLY, Delay time	Y	OPT, Option
C	AUTO <sup>Note</sup>	Z	ACC, Acceleration time <sup>Note</sup>
D	Reserved	U	DEC, Deceleration time <sup>Note</sup>

8

Definitions are as follows:

■ YX

Y: OPT, Option				X: TYPE, Path type
Bit 3	Bit 2	Bit 1	Bit 0	
-	UNIT	AUTO	INS	1: SPEED, constant speed control.
CMD		OVLP	INS	2: SINGLE, positioning control. It stops when finished. 3: AUTO, positioning control. It automatically loads the next path when finished.
-	-	-	INS	7: JUMP, jump to the specified path.
-	ROM	AUTO	INS	8: WRITE, write specified parameter to specified path.
DIR		OVLP	INS	A: INDEX, rotary axis position control.
-	-	-	-	B: STATEMENT, statement / arithmetic operation.

TYPE path type: when 1, 2, or 3 is executed, the motor operation can be interrupted and stopped by DI.STP and software limits.

INS: interrupts the previous path when the current path is executed.

OVLP: allow overlapping of the next path. Overlapping is not allowed in Speed mode. When you set an Overlap function in Position mode, DLY has no function.

AUTO: once current PR path is finished, automatically load the next path.

CMD, DIR, ROM, and UNIT: refer to Section 7.1.3 Motion Control commands.

■ UZ

U: DEC, Deceleration time	Z: ACC, Acceleration time	Corresponding parameter	Default value (ms)
0	0	P5.020	200
1	1	P5.021	300
2	2	P5.022	500
3	3	P5.023	600
4	4	P5.024	800
5	5	P5.025	900
6	6	P5.026	1000
7	7	P5.027	1200
8	8	P5.028	1500
9	9	P5.029	2000
10	10	P5.030	2500
11	11	P5.031	3000
12	12	P5.032	5000
13	13	P5.033	8000
14	14	P5.034	50
15	15	P5.035	30

■ A: SPD, target speed

A	Corresponding parameter	Default value (rpm)
0	P5.060	20
1	P5.061	50
2	P5.062	100
3	P5.063	200
4	P5.064	300
5	P5.065	500
6	P5.066	600
7	P5.067	800
8	P5.068	1000
9	P5.069	1300
10	P5.070	1500
11	P5.071	1800
12	P5.072	2000
13	P5.073	2300
14	P5.074	2500
15	P5.075	3000

■ B: DLY, delay time

B	Corresponding parameter	Default value (ms)
0	P5.040	0
1	P5.041	100
2	P5.042	200
3	P5.043	400
4	P5.044	500
5	P5.045	800
6	P5.046	1000
7	P5.047	1500
8	P5.048	2000
9	P5.049	2500
10	P5.050	3000
11	P5.051	3500
12	P5.052	4000
13	P5.053	4500
14	P5.054	5000
15	P5.055	5500

■ C: AUTO; once current PR path is finished, automatically load the next path

This function is enabled only when P6.002.X = A (rotary axis position control).

Description of each bit:

Bit	Function	Description
Bit 0, Bit 1	Reserved	-
Bit 2	AUTO	0: disable auto function 1: once the PR path is finished, automatically load the next path

Note: the parameter format definition [C, A, U, Z] is different from the preceding table when the path type is [8]: write the specified parameter to the specified path and [B]: statement / arithmetic operation. Refer to Chapter 7 for detailed instructions.

8

<b>P6.003</b>	<b>PATH 1 data</b>		<b>Address: 0606H 0607H</b>	
Default:	0	Control mode:	PR	
Unit:	-	Setting range:	-2147483648 to +2147483647	
Format:	DEC	Data size:	32-bit	

Settings:

P6.002 defines the property of the target point and P6.003 defines the target position of P6.002 or the target path for the Jump command.

<b>P6.004</b>	<b>PATH 2 definition</b>		<b>Address: 0608H 0609H</b>	
Default:	0x00000000	Control mode:	PR	
Unit:	-	Setting range:	0x00000000 - 0xFFFFFFFF	
Format:	HEX	Data size:	32-bit	

Settings:

Refer to the description of P6.002.

<b>P6.005</b>	<b>PATH 2 data</b>		<b>Address: 060AH 060BH</b>	
Default:	0	Control mode:	PR	
Unit:	-	Setting range:	-2147483648 to +2147483647	
Format:	DEC	Data size:	32-bit	

Settings:

Refer to the description of P6.003.

<b>P6.006</b>	<b>PATH 3 definition</b>		<b>Address: 060CH 060DH</b>	
Default:	0x00000000	Control mode:	PR	
Unit:	-	Setting range:	0x00000000 - 0xFFFFFFFF	
Format:	HEX	Data size:	32-bit	

Settings:

Refer to the description of P6.002.

<b>P6.007</b>	<b>PATH 3 data</b>		<b>Address: 060EH 060FH</b>	
Default:	0	Control mode:	PR	
Unit:	-	Setting range:	-2147483648 to +2147483647	
Format:	DEC	Data size:	32-bit	

Settings:

Refer to the description of P6.003.

<b>P6.008</b>	<b>PATH 4 definition</b>		<b>Address: 0610H 0611H</b>	
Default:	0x00000000	Control mode:	PR	
Unit:	-	Setting range:	0x00000000 - 0xFFFFFFFF	
Format:	HEX	Data size:	32-bit	

Settings:

Refer to the description of P6.002.

<b>P6.009</b>	<b>PATH 4 data</b>		<b>Address: 0612H 0613H</b>	
Default:	0	Control mode:	PR	
Unit:	-	Setting range:	-2147483648 to +2147483647	
Format:	DEC	Data size:	32-bit	

Settings:

Refer to the description of P6.003.

<b>P6.010</b>	<b>PATH 5 definition</b>		<b>Address: 0614H 0615H</b>	
Default:	0x00000000	Control mode:	PR	
Unit:	-	Setting range:	0x00000000 - 0xFFFFFFFF	
Format:	HEX	Data size:	32-bit	

Settings:

Refer to the description of P6.002.

<b>P6.011</b>	<b>PATH 5 data</b>		<b>Address: 0616H 0617H</b>	
Default:	0	Control mode:	PR	
Unit:	-	Setting range:	-2147483648 to +2147483647	
Format:	DEC	Data size:	32-bit	

Settings:

Refer to the description of P6.003.

<b>P6.012</b>	<b>PATH 6 definition</b>		<b>Address: 0618H 0619H</b>	
Default:	0x00000000	Control mode:	PR	
Unit:	-	Setting range:	0x00000000 - 0xFFFFFFFF	
Format:	HEX	Data size:	32-bit	

Settings:

Refer to the description of P6.002.



8

<b>P6.013</b>	<b>PATH 6 data</b>	<b>Address: 061AH 061BH</b>	
Default:	0	Control mode:	PR
Unit:	-	Setting range:	-2147483648 to +2147483647
Format:	DEC	Data size:	32-bit

Settings:

Refer to the description of P6.003.

<b>P6.014</b>	<b>PATH 7 definition</b>	<b>Address: 061CH 061DH</b>	
Default:	0x00000000	Control mode:	PR
Unit:	-	Setting range:	0x00000000 - 0xFFFFFFFF
Format:	HEX	Data size:	32-bit

Settings:

Refer to the description of P6.002.

<b>P6.015</b>	<b>PATH 7 data</b>	<b>Address: 061EH 061FH</b>	
Default:	0	Control mode:	PR
Unit:	-	Setting range:	-2147483648 to +2147483647
Format:	DEC	Data size:	32-bit

Settings:

Refer to the description of P6.003.

<b>P6.016</b>	<b>PATH 8 definition</b>	<b>Address: 0620H 0621H</b>	
Default:	0x00000000	Control mode:	PR
Unit:	-	Setting range:	0x00000000 - 0xFFFFFFFF
Format:	HEX	Data size:	32-bit

Settings:

Refer to the description of P6.002.

<b>P6.017</b>	<b>PATH 8 data</b>	<b>Address: 0622H 0623H</b>	
Default:	0	Control mode:	PR
Unit:	-	Setting range:	-2147483648 to +2147483647
Format:	DEC	Data size:	32-bit

Settings:

Refer to the description of P6.003.

<b>P6.018</b>	<b>PATH 9 definition</b>		<b>Address: 0624H 0625H</b>	
Default:	0x00000000	Control mode:	PR	
Unit:	-	Setting range:	0x00000000 - 0xFFFFFFFF	
Format:	HEX	Data size:	32-bit	

Settings:

Refer to the description of P6.002.

<b>P6.019</b>	<b>PATH 9 data</b>		<b>Address: 0626H 0627H</b>	
Default:	0	Control mode:	PR	
Unit:	-	Setting range:	-2147483648 to +2147483647	
Format:	DEC	Data size:	32-bit	

Settings:

Refer to the description of P6.003.

<b>P6.020</b>	<b>PATH 10 definition</b>		<b>Address: 0628H 0629H</b>	
Default:	0x00000000	Control mode:	PR	
Unit:	-	Setting range:	0x00000000 - 0xFFFFFFFF	
Format:	HEX	Data size:	32-bit	

Settings:

Refer to the description of P6.002.

<b>P6.021</b>	<b>PATH 10 data</b>		<b>Address: 062AH 062BH</b>	
Default:	0	Control mode:	PR	
Unit:	-	Setting range:	-2147483648 to +2147483647	
Format:	DEC	Data size:	32-bit	

Settings:

Refer to the description of P6.003.

<b>P6.022</b>	<b>PATH 11 definition</b>		<b>Address: 062CH 062DH</b>	
Default:	0x00000000	Control mode:	PR	
Unit:	-	Setting range:	0x00000000 - 0xFFFFFFFF	
Format:	HEX	Data size:	32-bit	

Settings:

Refer to the description of P6.002.

8

<b>P6.023</b>	<b>PATH 11 data</b>	<b>Address: 062EH 062FH</b>	
Default:	0	Control mode:	PR
Unit:	-	Setting range:	-2147483648 to +2147483647
Format:	DEC	Data size:	32-bit

Settings:

Refer to the description of P6.003.

<b>P6.024</b>	<b>PATH 12 definition</b>	<b>Address: 0630H 0631H</b>	
Default:	0x00000000	Control mode:	PR
Unit:	-	Setting range:	0x00000000 - 0xFFFFFFFF
Format:	HEX	Data size:	32-bit

Settings:

Refer to the description of P6.002.

<b>P6.025</b>	<b>PATH 12 data</b>	<b>Address: 0632H 0633H</b>	
Default:	0	Control mode:	PR
Unit:	-	Setting range:	-2147483648 to +2147483647
Format:	DEC	Data size:	32-bit

Settings:

Refer to the description of P6.003.

<b>P6.026</b>	<b>PATH 13 definition</b>	<b>Address: 0634H 0635H</b>	
Default:	0x00000000	Control mode:	PR
Unit:	-	Setting range:	0x00000000 - 0xFFFFFFFF
Format:	HEX	Data size:	32-bit

Settings:

Refer to the description of P6.002.

<b>P6.027</b>	<b>PATH 13 data</b>	<b>Address: 0636H 0637H</b>	
Default:	0	Control mode:	PR
Unit:	-	Setting range:	-2147483648 to +2147483647
Format:	DEC	Data size:	32-bit

Settings:

Refer to the description of P6.003.

<b>P6.028</b>	<b>PATH 14 definition</b>		<b>Address: 0638H 0639H</b>	
Default:	0x00000000	Control mode:	PR	
Unit:	-	Setting range:	0x00000000 - 0xFFFFFFFF	
Format:	HEX	Data size:	32-bit	

Settings:

Refer to the description of P6.002.

<b>P6.029</b>	<b>PATH 14 data</b>		<b>Address: 063AH 063BH</b>	
Default:	0	Control mode:	PR	
Unit:	-	Setting range:	-2147483648 to +2147483647	
Format:	DEC	Data size:	32-bit	

Settings:

Refer to the description of P6.003.

<b>P6.030</b>	<b>PATH 15 definition</b>		<b>Address: 063CH 063DH</b>	
Default:	0x00000000	Control mode:	PR	
Unit:	-	Setting range:	0x00000000 - 0xFFFFFFFF	
Format:	HEX	Data size:	32-bit	

Settings:

Refer to the description of P6.002.

<b>P6.031</b>	<b>PATH 15 data</b>		<b>Address: 063EH 063FH</b>	
Default:	0	Control mode:	PR	
Unit:	-	Setting range:	-2147483648 to +2147483647	
Format:	DEC	Data size:	32-bit	

Settings:

Refer to the description of P6.003.

<b>P6.032</b>	<b>PATH 16 definition</b>		<b>Address: 0640H 0641H</b>	
Default:	0x00000000	Control mode:	PR	
Unit:	-	Setting range:	0x00000000 - 0xFFFFFFFF	
Format:	HEX	Data size:	32-bit	

Settings:

Refer to the description of P6.002.

8

<b>P6.033</b>	<b>PATH 16 data</b>		<b>Address: 0642H 0643H</b>	
Default:	0	Control mode:	PR	
Unit:	-	Setting range:	-2147483648 to +2147483647	
Format:	DEC	Data size:	32-bit	

Settings:

Refer to the description of P6.003.

<b>P6.034</b>	<b>PATH 17 definition</b>		<b>Address: 0644H 0645H</b>	
Default:	0x00000000	Control mode:	PR	
Unit:	-	Setting range:	0x00000000 - 0xFFFFFFFF	
Format:	HEX	Data size:	32-bit	

Settings:

Refer to the description of P6.002.

<b>P6.035</b>	<b>PATH 17 data</b>		<b>Address: 0646H 0647H</b>	
Default:	0	Control mode:	PR	
Unit:	-	Setting range:	-2147483648 to +2147483647	
Format:	DEC	Data size:	32-bit	

Settings:

Refer to the description of P6.003.

<b>P6.036</b>	<b>PATH 18 definition</b>		<b>Address: 0648H 0649H</b>	
Default:	0x00000000	Control mode:	PR	
Unit:	-	Setting range:	0x00000000 - 0xFFFFFFFF	
Format:	HEX	Data size:	32-bit	

Settings:

Refer to the description of P6.002.

<b>P6.037</b>	<b>PATH 18 data</b>		<b>Address: 064AH 064BH</b>	
Default:	0	Control mode:	PR	
Unit:	-	Setting range:	-2147483648 to +2147483647	
Format:	DEC	Data size:	32-bit	

Settings:

Refer to the description of P6.003.

<b>P6.038</b>	<b>PATH 19 definition</b>	<b>Address: 064CH 064DH</b>	
Default:	0x00000000	Control mode:	PR
Unit:	-	Setting range:	0x00000000 - 0xFFFFFFFF
Format:	HEX	Data size:	32-bit

Settings:

Refer to the description of P6.002.

<b>P6.039</b>	<b>PATH 19 data</b>	<b>Address: 064EH 064FH</b>	
Default:	0	Control mode:	PR
Unit:	-	Setting range:	-2147483648 to +2147483647
Format:	DEC	Data size:	32-bit

Settings:

Refer to the description of P6.003.

<b>P6.040</b>	<b>PATH 20 definition</b>	<b>Address: 0650H 0651H</b>	
Default:	0x00000000	Control mode:	PR
Unit:	-	Setting range:	0x00000000 - 0xFFFFFFFF
Format:	HEX	Data size:	32-bit

Settings:

Refer to the description of P6.002.

<b>P6.041</b>	<b>PATH 20 data</b>	<b>Address: 0652H 0653H</b>	
Default:	0	Control mode:	PR
Unit:	-	Setting range:	-2147483648 to +2147483647
Format:	DEC	Data size:	32-bit

Settings:

Refer to the description of P6.003.

<b>P6.042</b>	<b>PATH 21 definition</b>	<b>Address: 0654H 0655H</b>	
Default:	0x00000000	Control mode:	PR
Unit:	-	Setting range:	0x00000000 - 0xFFFFFFFF
Format:	HEX	Data size:	32-bit

Settings:

Refer to the description of P6.002.

8

<b>P6.043</b>	<b>PATH 21 data</b>	<b>Address: 0656H 0657H</b>	
Default:	0	Control mode:	PR
Unit:	-	Setting range:	-2147483648 to +2147483647
Format:	DEC	Data size:	32-bit

Settings:

Refer to the description of P6.003.

<b>P6.044</b>	<b>PATH 22 definition</b>	<b>Address: 0658H 0659H</b>	
Default:	0x00000000	Control mode:	PR
Unit:	-	Setting range:	0x00000000 - 0xFFFFFFFF
Format:	HEX	Data size:	32-bit

Settings:

Refer to the description of P6.002.

<b>P6.045</b>	<b>PATH 22 data</b>	<b>Address: 065AH 065BH</b>	
Default:	0	Control mode:	PR
Unit:	-	Setting range:	-2147483648 to +2147483647
Format:	DEC	Data size:	32-bit

Settings:

Refer to the description of P6.003.

<b>P6.046</b>	<b>PATH 23 definition</b>	<b>Address: 065CH 065DH</b>	
Default:	0x00000000	Control mode:	PR
Unit:	-	Setting range:	0x00000000 - 0xFFFFFFFF
Format:	HEX	Data size:	32-bit

Settings:

Refer to the description of P6.002.

<b>P6.047</b>	<b>PATH 23 data</b>	<b>Address: 065EH 065FH</b>	
Default:	0	Control mode:	PR
Unit:	-	Setting range:	-2147483648 to +2147483647
Format:	DEC	Data size:	32-bit

Settings:

Refer to the description of P6.003.

<b>P6.048</b>	<b>PATH 24 definition</b>		<b>Address: 0660H 0661H</b>	
Default:	0x00000000	Control mode:	PR	
Unit:	-	Setting range:	0x00000000 - 0xFFFFFFFF	
Format:	HEX	Data size:	32-bit	

Settings:

Refer to the description of P6.002.

<b>P6.049</b>	<b>PATH 24 data</b>		<b>Address: 0662H 0663H</b>	
Default:	0	Control mode:	PR	
Unit:	-	Setting range:	-2147483648 to +2147483647	
Format:	DEC	Data size:	32-bit	

Settings:

Refer to the description of P6.003.

<b>P6.050</b>	<b>PATH 25 definition</b>		<b>Address: 0664H 0665H</b>	
Default:	0x00000000	Control mode:	PR	
Unit:	-	Setting range:	0x00000000 - 0xFFFFFFFF	
Format:	HEX	Data size:	32-bit	

Settings:

Refer to the description of P6.002.

<b>P6.051</b>	<b>PATH 25 data</b>		<b>Address: 0666H 0667H</b>	
Default:	0	Control mode:	PR	
Unit:	-	Setting range:	-2147483648 to +2147483647	
Format:	DEC	Data size:	32-bit	

Settings:

Refer to the description of P6.003.

<b>P6.052</b>	<b>PATH 26 definition</b>		<b>Address: 0668H 0669H</b>	
Default:	0x00000000	Control mode:	PR	
Unit:	-	Setting range:	0x00000000 - 0xFFFFFFFF	
Format:	HEX	Data size:	32-bit	

Settings:

Refer to the description of P6.002.



8

<b>P6.053</b>	<b>PATH 26 data</b>	<b>Address: 066AH 066BH</b>	
Default:	0	Control mode:	PR
Unit:	-	Setting range:	-2147483648 to +2147483647
Format:	DEC	Data size:	32-bit

Settings:

Refer to the description of P6.003.

<b>P6.054</b>	<b>PATH 27 definition</b>	<b>Address: 066CH 066DH</b>	
Default:	0x00000000	Control mode:	PR
Unit:	-	Setting range:	0x00000000 - 0xFFFFFFFF
Format:	HEX	Data size:	32-bit

Settings:

Refer to the description of P6.002.

<b>P6.055</b>	<b>PATH 27 data</b>	<b>Address: 066EH 066FH</b>	
Default:	0	Control mode:	PR
Unit:	-	Setting range:	-2147483648 to +2147483647
Format:	DEC	Data size:	32-bit

Settings:

Refer to the description of P6.003.

<b>P6.056</b>	<b>PATH 28 definition</b>	<b>Address: 0670H 0671H</b>	
Default:	0x00000000	Control mode:	PR
Unit:	-	Setting range:	0x00000000 - 0xFFFFFFFF
Format:	HEX	Data size:	32-bit

Settings:

Refer to the description of P6.002.

<b>P6.057</b>	<b>PATH 28 data</b>	<b>Address: 0672H 0673H</b>	
Default:	0	Control mode:	PR
Unit:	-	Setting range:	-2147483648 to +2147483647
Format:	DEC	Data size:	32-bit

Settings:

Refer to the description of P6.003.

<b>P6.058</b>	<b>PATH 29 definition</b>		<b>Address: 0674H 0675H</b>	
Default:	0x00000000	Control mode:	PR	
Unit:	-	Setting range:	0x00000000 - 0xFFFFFFFF	
Format:	HEX	Data size:	32-bit	

Settings:

Refer to the description of P6.002.

<b>P6.059</b>	<b>PATH 29 data</b>		<b>Address: 0676H 0677H</b>	
Default:	0	Control mode:	PR	
Unit:	-	Setting range:	-2147483648 to +2147483647	
Format:	DEC	Data size:	32-bit	

Settings:

Refer to the description of P6.003.

<b>P6.060</b>	<b>PATH 30 definition</b>		<b>Address: 0678H 0679H</b>	
Default:	0x00000000	Control mode:	PR	
Unit:	-	Setting range:	0x00000000 - 0xFFFFFFFF	
Format:	HEX	Data size:	32-bit	

Settings:

Refer to the description of P6.002.

<b>P6.061</b>	<b>PATH 30 data</b>		<b>Address: 067AH 067BH</b>	
Default:	0	Control mode:	PR	
Unit:	-	Setting range:	-2147483648 to +2147483647	
Format:	DEC	Data size:	32-bit	

Settings:

Refer to the description of P6.003.

<b>P6.062</b>	<b>PATH 31 definition</b>		<b>Address: 067CH 067DH</b>	
Default:	0x00000000	Control mode:	PR	
Unit:	-	Setting range:	0x00000000 - 0xFFFFFFFF	
Format:	HEX	Data size:	32-bit	

Settings:

Refer to the description of P6.002.

8

<b>P6.063</b>	<b>PATH 31 data</b>		<b>Address: 067EH 067FH</b>	
Default:	0	Control mode:	PR	
Unit:	-	Setting range:	-2147483648 to +2147483647	
Format:	DEC	Data size:	32-bit	

Settings:

Refer to the description of P6.003.

<b>P6.064</b>	<b>PATH 32 definition</b>		<b>Address: 0680H 0681H</b>	
Default:	0x00000000	Control mode:	PR	
Unit:	-	Setting range:	0x00000000 - 0xFFFFFFFF	
Format:	HEX	Data size:	32-bit	

Settings:

Refer to the description of P6.002.

<b>P6.065</b>	<b>PATH 32 data</b>		<b>Address: 0682H 0683H</b>	
Default:	0	Control mode:	PR	
Unit:	-	Setting range:	-2147483648 to +2147483647	
Format:	DEC	Data size:	32-bit	

Settings:

Refer to the description of P6.003.

<b>P6.066</b>	<b>PATH 33 definition</b>		<b>Address: 0684H 0685H</b>	
Default:	0x00000000	Control mode:	PR	
Unit:	-	Setting range:	0x00000000 - 0xFFFFFFFF	
Format:	HEX	Data size:	32-bit	

Settings:

Refer to the description of P6.002.

<b>P6.067</b>	<b>PATH 33 data</b>		<b>Address: 0686H 0687H</b>	
Default:	0	Control mode:	PR	
Unit:	-	Setting range:	-2147483648 to +2147483647	
Format:	DEC	Data size:	32-bit	

Settings:

Refer to the description of P6.003.

<b>P6.068</b>	<b>PATH 34 definition</b>		<b>Address: 0688H 0689H</b>	
Default:	0x00000000	Control mode:	PR	
Unit:	-	Setting range:	0x00000000 - 0xFFFFFFFF	
Format:	HEX	Data size:	32-bit	

Settings:

Refer to the description of P6.002.

<b>P6.069</b>	<b>PATH 34 data</b>		<b>Address: 068AH 068BH</b>	
Default:	0	Control mode:	PR	
Unit:	-	Setting range:	-2147483648 to +2147483647	
Format:	DEC	Data size:	32-bit	

Settings:

Refer to the description of P6.003.

<b>P6.070</b>	<b>PATH 35 definition</b>		<b>Address: 068CH 068DH</b>	
Default:	0x00000000	Control mode:	PR	
Unit:	-	Setting range:	0x00000000 - 0xFFFFFFFF	
Format:	HEX	Data size:	32-bit	

Settings:

Refer to the description of P6.002.

<b>P6.071</b>	<b>PATH 35 data</b>		<b>Address: 068EH 068FH</b>	
Default:	0	Control mode:	PR	
Unit:	-	Setting range:	-2147483648 to +2147483647	
Format:	DEC	Data size:	32-bit	

Settings:

Refer to the description of P6.003.

<b>P6.072</b>	<b>PATH 36 definition</b>		<b>Address: 0690H 0691H</b>	
Default:	0x00000000	Control mode:	PR	
Unit:	-	Setting range:	0x00000000 - 0xFFFFFFFF	
Format:	HEX	Data size:	32-bit	

Settings:

Refer to the description of P6.002.

8

<b>P6.073</b>	<b>PATH 36 data</b>		<b>Address: 0692H 0693H</b>	
Default:	0	Control mode:	PR	
Unit:	-	Setting range:	-2147483648 to +2147483647	
Format:	DEC	Data size:	32-bit	

Settings:

Refer to the description of P6.003.

<b>P6.074</b>	<b>PATH 37 definition</b>		<b>Address: 0694H 0695H</b>	
Default:	0x00000000	Control mode:	PR	
Unit:	-	Setting range:	0x00000000 - 0xFFFFFFFF	
Format:	HEX	Data size:	32-bit	

Settings:

Refer to the description of P6.002.

<b>P6.075</b>	<b>PATH 37 data</b>		<b>Address: 0696H 0697H</b>	
Default:	0	Control mode:	PR	
Unit:	-	Setting range:	-2147483648 to +2147483647	
Format:	DEC	Data size:	32-bit	

Settings:

Refer to the description of P6.003.

<b>P6.076</b>	<b>PATH 38 definition</b>		<b>Address: 0698H 0699H</b>	
Default:	0x00000000	Control mode:	PR	
Unit:	-	Setting range:	0x00000000 - 0xFFFFFFFF	
Format:	HEX	Data size:	32-bit	

Settings:

Refer to the description of P6.002.

<b>P6.077</b>	<b>PATH 38 data</b>		<b>Address: 069AH 069BH</b>	
Default:	0	Control mode:	PR	
Unit:	-	Setting range:	-2147483648 to +2147483647	
Format:	DEC	Data size:	32-bit	

Settings:

Refer to the description of P6.003.

<b>P6.078</b>	<b>PATH 39 definition</b>		<b>Address: 069CH 069DH</b>	
Default:	0x00000000	Control mode:	PR	
Unit:	-	Setting range:	0x00000000 - 0xFFFFFFFF	
Format:	HEX	Data size:	32-bit	

Settings:

Refer to the description of P6.002.

<b>P6.079</b>	<b>PATH 39 data</b>		<b>Address: 069EH 069FH</b>	
Default:	0	Control mode:	PR	
Unit:	-	Setting range:	-2147483648 to +2147483647	
Format:	DEC	Data size:	32-bit	

Settings:

Refer to the description of P6.003.

<b>P6.080</b>	<b>PATH 40 definition</b>		<b>Address: 06A0H 06A1H</b>	
Default:	0x00000000	Control mode:	PR	
Unit:	-	Setting range:	0x00000000 - 0xFFFFFFFF	
Format:	HEX	Data size:	32-bit	

Settings:

Refer to the description of P6.002.

<b>P6.081</b>	<b>PATH 40 data</b>		<b>Address: 06A2H 06A3H</b>	
Default:	0	Control mode:	PR	
Unit:	-	Setting range:	-2147483648 to +2147483647	
Format:	DEC	Data size:	32-bit	

Settings:

Refer to the description of P6.003.

<b>P6.082</b>	<b>PATH 41 definition</b>		<b>Address: 06A4H 06A5H</b>	
Default:	0x00000000	Control mode:	PR	
Unit:	-	Setting range:	0x00000000 - 0xFFFFFFFF	
Format:	HEX	Data size:	32-bit	

Settings:

Refer to the description of P6.002.

8

<b>P6.083</b>	<b>PATH 41 data</b>		<b>Address: 06A6H 06A7H</b>	
Default:	0	Control mode:	PR	
Unit:	-	Setting range:	-2147483648 to +2147483647	
Format:	DEC	Data size:	32-bit	

Settings:

Refer to the description of P6.003.

<b>P6.084</b>	<b>PATH 42 definition</b>		<b>Address: 06A8H 06A9H</b>	
Default:	0x00000000	Control mode:	PR	
Unit:	-	Setting range:	0x00000000 - 0xFFFFFFFF	
Format:	HEX	Data size:	32-bit	

Settings:

Refer to the description of P6.002.

<b>P6.085</b>	<b>PATH 42 data</b>		<b>Address: 06AAH 06ABH</b>	
Default:	0	Control mode:	PR	
Unit:	-	Setting range:	-2147483648 to +2147483647	
Format:	DEC	Data size:	32-bit	

Settings:

Refer to the description of P6.003.

<b>P6.086</b>	<b>PATH 43 definition</b>		<b>Address: 06ACH 06ADH</b>	
Default:	0x00000000	Control mode:	PR	
Unit:	-	Setting range:	0x00000000 - 0xFFFFFFFF	
Format:	HEX	Data size:	32-bit	

Settings:

Refer to the description of P6.002.

<b>P6.087</b>	<b>PATH 43 data</b>		<b>Address: 06AEH 06AFH</b>	
Default:	0	Control mode:	PR	
Unit:	-	Setting range:	-2147483648 to +2147483647	
Format:	DEC	Data size:	32-bit	

Settings:

Refer to the description of P6.003.

<b>P6.088</b>	<b>PATH 44 definition</b>		<b>Address: 06B0H 06B1H</b>	
Default:	0x00000000	Control mode:	PR	
Unit:	-	Setting range:	0x00000000 - 0xFFFFFFFF	
Format:	HEX	Data size:	32-bit	

Settings:

Refer to the description of P6.002.

<b>P6.089</b>	<b>PATH 44 data</b>		<b>Address: 06B2H 06B3H</b>	
Default:	0	Control mode:	PR	
Unit:	-	Setting range:	-2147483648 to +2147483647	
Format:	DEC	Data size:	32-bit	

Settings:

Refer to the description of P6.003.

<b>P6.090</b>	<b>PATH 45 definition</b>		<b>Address: 06B4H 06B5H</b>	
Default:	0x00000000	Control mode:	PR	
Unit:	-	Setting range:	0x00000000 - 0xFFFFFFFF	
Format:	HEX	Data size:	32-bit	

Settings:

Refer to the description of P6.002.

<b>P6.091</b>	<b>PATH 45 data</b>		<b>Address: 06B6H 06B7H</b>	
Default:	0	Control mode:	PR	
Unit:	-	Setting range:	-2147483648 to +2147483647	
Format:	DEC	Data size:	32-bit	

Settings:

Refer to the description of P6.003.

<b>P6.092</b>	<b>PATH 46 definition</b>		<b>Address: 06B8H 06B9H</b>	
Default:	0x00000000	Control mode:	PR	
Unit:	-	Setting range:	0x00000000 - 0xFFFFFFFF	
Format:	HEX	Data size:	32-bit	

Settings:

Refer to the description of P6.002.



8

<b>P6.093</b>	<b>PATH 46 data</b>	<b>Address: 06BAH 06BBH</b>	
Default:	0	Control mode:	PR
Unit:	-	Setting range:	-2147483648 to +2147483647
Format:	DEC	Data size:	32-bit

Settings:

Refer to the description of P6.003.

<b>P6.094</b>	<b>PATH 47 definition</b>	<b>Address: 06BCH 06BDH</b>	
Default:	0x00000000	Control mode:	PR
Unit:	-	Setting range:	0x00000000 - 0xFFFFFFFF
Format:	HEX	Data size:	32-bit

Settings:

Refer to the description of P6.002.

<b>P6.095</b>	<b>PATH 47 data</b>	<b>Address: 06BEH 06BFH</b>	
Default:	0	Control mode:	PR
Unit:	-	Setting range:	-2147483648 to +2147483647
Format:	DEC	Data size:	32-bit

Settings:

Refer to the description of P6.003.

<b>P6.096</b>	<b>PATH 48 definition</b>	<b>Address: 06C0H 06C1H</b>	
Default:	0x00000000	Control mode:	PR
Unit:	-	Setting range:	0x00000000 - 0xFFFFFFFF
Format:	HEX	Data size:	32-bit

Settings:

Refer to the description of P6.002.

<b>P6.097</b>	<b>PATH 48 data</b>	<b>Address: 06C2H 06C3H</b>	
Default:	0	Control mode:	PR
Unit:	-	Setting range:	-2147483648 to +2147483647
Format:	DEC	Data size:	32-bit

Settings:

Refer to the description of P6.003.

<b>P6.098</b>	<b>PATH 49 definition</b>		<b>Address: 06C4H 06C5H</b>
Default:	0x00000000	Control mode:	PR
Unit:	-	Setting range:	0x00000000 - 0xFFFFFFFF
Format:	HEX	Data size:	32-bit

Settings:

Refer to the description of P6.002.

<b>P6.099</b>	<b>PATH 49 data</b>		<b>Address: 06C6H 06C7H</b>
Default:	0	Control mode:	PR
Unit:	-	Setting range:	-2147483648 to +2147483647
Format:	DEC	Data size:	32-bit

Settings:

Refer to the description of P6.003.

8

**P7.xxx PR parameters**

<b>P7.000</b>	<b>PATH 50 definition</b>	<b>Address: 0700H 0701H</b>	
Default:	0x00000000	Control mode:	PR
Unit:	-	Setting range:	0x00000000 - 0xFFFFFFFF
Format:	HEX	Data size:	32-bit

Settings:

Refer to the description of P6.002.

<b>P7.001</b>	<b>PATH 50 data</b>	<b>Address: 0702H 0703H</b>	
Default:	0	Control mode:	PR
Unit:	-	Setting range:	-2147483648 to +2147483647
Format:	DEC	Data size:	32-bit

Settings:

Refer to the description of P6.003.

<b>P7.002</b>	<b>PATH 51 definition</b>	<b>Address: 0704H 0705H</b>	
Default:	0x00000000	Control mode:	PR
Unit:	-	Setting range:	0x00000000 - 0xFFFFFFFF
Format:	HEX	Data size:	32-bit

Settings:

Refer to the description of P6.002.

<b>P7.003</b>	<b>PATH 51 data</b>	<b>Address: 0706H 0707H</b>	
Default:	0	Control mode:	PR
Unit:	-	Setting range:	-2147483648 to +2147483647
Format:	DEC	Data size:	32-bit

Settings:

Refer to the description of P6.003.

<b>P7.004</b>	<b>PATH 52 definition</b>	<b>Address: 0708H 0709H</b>	
Default:	0x00000000	Control mode:	PR
Unit:	-	Setting range:	0x00000000 - 0xFFFFFFFF
Format:	HEX	Data size:	32-bit

Settings:

Refer to the description of P6.002.

<b>P7.005</b>	<b>PATH 52 data</b>	<b>Address: 070AH 070BH</b>	
Default:	0	Control mode:	PR
Unit:	-	Setting range:	-2147483648 to +2147483647
Format:	DEC	Data size:	32-bit

Settings:

Refer to the description of P6.003.

<b>P7.006</b>	<b>PATH 53 definition</b>	<b>Address: 070CH 070DH</b>	
Default:	0x00000000	Control mode:	PR
Unit:	-	Setting range:	0x00000000 - 0xFFFFFFFF
Format:	HEX	Data size:	32-bit

Settings:

Refer to the description of P6.002.

<b>P7.007</b>	<b>PATH 53 data</b>	<b>Address: 070EH 070FH</b>	
Default:	0	Control mode:	PR
Unit:	-	Setting range:	-2147483648 to +2147483647
Format:	DEC	Data size:	32-bit

Settings:

Refer to the description of P6.003.

<b>P7.008</b>	<b>PATH 54 definition</b>	<b>Address: 0710H 0711H</b>	
Default:	0x00000000	Control mode:	PR
Unit:	-	Setting range:	0x00000000 - 0xFFFFFFFF
Format:	HEX	Data size:	32-bit

Settings:

Refer to the description of P6.002.

<b>P7.009</b>	<b>PATH 54 data</b>	<b>Address: 0712H 0713H</b>	
Default:	0	Control mode:	PR
Unit:	-	Setting range:	-2147483648 to +2147483647
Format:	DEC	Data size:	32-bit

Settings:

Refer to the description of P6.003.

8

<b>P7.010</b>	<b>PATH 55 definition</b>		<b>Address: 0714H 0715H</b>	
Default:	0x00000000	Control mode:	PR	
Unit:	-	Setting range:	0x00000000 - 0xFFFFFFFF	
Format:	HEX	Data size:	32-bit	

Settings:

Refer to the description of P6.002.

<b>P7.011</b>	<b>PATH 55 data</b>		<b>Address: 0716H 0717H</b>	
Default:	0	Control mode:	PR	
Unit:	-	Setting range:	-2147483648 to +2147483647	
Format:	DEC	Data size:	32-bit	

Settings:

Refer to the description of P6.003.

<b>P7.012</b>	<b>PATH 56 definition</b>		<b>Address: 0718H 0719H</b>	
Default:	0x00000000	Control mode:	PR	
Unit:	-	Setting range:	0x00000000 - 0xFFFFFFFF	
Format:	HEX	Data size:	32-bit	

Settings:

Refer to the description of P6.002.

<b>P7.013</b>	<b>PATH 56 data</b>		<b>Address: 071AH 071BH</b>	
Default:	0	Control mode:	PR	
Unit:	-	Setting range:	-2147483648 to +2147483647	
Format:	DEC	Data size:	32-bit	

Settings:

Refer to the description of P6.003.

<b>P7.014</b>	<b>PATH 57 definition</b>		<b>Address: 071CH 071DH</b>	
Default:	0x00000000	Control mode:	PR	
Unit:	-	Setting range:	0x00000000 - 0xFFFFFFFF	
Format:	HEX	Data size:	32-bit	

Settings:

Refer to the description of P6.002.

<b>P7.015</b>	<b>PATH 57 data</b>		<b>Address: 071EH 071FH</b>	
Default:	0	Control mode:	PR	
Unit:	-	Setting range:	-2147483648 to +2147483647	
Format:	DEC	Data size:	32-bit	

Settings:

Refer to the description of P6.003.

<b>P7.016</b>	<b>PATH 58 definition</b>		<b>Address: 0720H 0721H</b>	
Default:	0x00000000	Control mode:	PR	
Unit:	-	Setting range:	0x00000000 - 0xFFFFFFFF	
Format:	HEX	Data size:	32-bit	

Settings:

Refer to the description of P6.002.

<b>P7.017</b>	<b>PATH 58 data</b>		<b>Address: 0722H 0723H</b>	
Default:	0	Control mode:	PR	
Unit:	-	Setting range:	-2147483648 to +2147483647	
Format:	DEC	Data size:	32-bit	

Settings:

Refer to the description of P6.003.

<b>P7.018</b>	<b>PATH 59 definition</b>		<b>Address: 0724H 0725H</b>	
Default:	0x00000000	Control mode:	PR	
Unit:	-	Setting range:	0x00000000 - 0xFFFFFFFF	
Format:	HEX	Data size:	32-bit	

Settings:

Refer to the description of P6.002.

<b>P7.019</b>	<b>PATH 59 data</b>		<b>Address: 0726H 0727H</b>	
Default:	0	Control mode:	PR	
Unit:	-	Setting range:	-2147483648 to +2147483647	
Format:	DEC	Data size:	32-bit	

Settings:

Refer to the description of P6.003.

8

<b>P7.020</b>	<b>PATH 60 definition</b>		<b>Address: 0728H 0729H</b>	
Default:	0x00000000	Control mode:	PR	
Unit:	-	Setting range:	0x00000000 - 0xFFFFFFFF	
Format:	HEX	Data size:	32-bit	

Settings:

Refer to the description of P6.002.

<b>P7.021</b>	<b>PATH 60 data</b>		<b>Address: 072AH 072BH</b>	
Default:	0	Control mode:	PR	
Unit:	-	Setting range:	-2147483648 to +2147483647	
Format:	DEC	Data size:	32-bit	

Settings:

Refer to the description of P6.003.

<b>P7.022</b>	<b>PATH 61 definition</b>		<b>Address: 072CH 072DH</b>	
Default:	0x00000000	Control mode:	PR	
Unit:	-	Setting range:	0x00000000 - 0xFFFFFFFF	
Format:	HEX	Data size:	32-bit	

Settings:

Refer to the description of P6.002.

<b>P7.023</b>	<b>PATH 61 data</b>		<b>Address: 072EH 072FH</b>	
Default:	0	Control mode:	PR	
Unit:	-	Setting range:	-2147483648 to +2147483647	
Format:	DEC	Data size:	32-bit	

Settings:

Refer to the description of P6.003.

<b>P7.024</b>	<b>PATH 62 definition</b>		<b>Address: 0730H 0731H</b>	
Default:	0x00000000	Control mode:	PR	
Unit:	-	Setting range:	0x00000000 - 0xFFFFFFFF	
Format:	HEX	Data size:	32-bit	

Settings:

Refer to the description of P6.002.

<b>P7.025</b>	<b>PATH 62 data</b>	<b>Address: 0732H 0733H</b>	
Default:	0	Control mode:	PR
Unit:	-	Setting range:	-2147483648 to +2147483647
Format:	DEC	Data size:	32-bit

Settings:

Refer to the description of P6.003.

<b>P7.026</b>	<b>PATH 63 definition</b>	<b>Address: 0734H 0735H</b>	
Default:	0x00000000	Control mode:	PR
Unit:	-	Setting range:	0x00000000 - 0xFFFFFFFF
Format:	HEX	Data size:	32-bit

Settings:

Refer to the description of P6.002.

<b>P7.027</b>	<b>PATH 63 data</b>	<b>Address: 0736H 0737H</b>	
Default:	0	Control mode:	PR
Unit:	-	Setting range:	-2147483648 to +2147483647
Format:	DEC	Data size:	32-bit

Settings:

Refer to the description of P6.003.

<b>P7.028</b>	<b>PATH 64 definition</b>	<b>Address: 0738H 0739H</b>	
Default:	0x00000000	Control mode:	PR
Unit:	-	Setting range:	0x00000000 - 0xFFFFFFFF
Format:	HEX	Data size:	32-bit

Settings:

Refer to the description of P6.002.

<b>P7.029</b>	<b>PATH 64 data</b>	<b>Address: 073AH 073BH</b>	
Default:	0	Control mode:	PR
Unit:	-	Setting range:	-2147483648 to +2147483647
Format:	DEC	Data size:	32-bit

Settings:

Refer to the description of P6.003.



8

<b>P7.030</b>	<b>PATH 65 definition</b>		<b>Address: 073CH 073DH</b>	
Default:	0x00000000	Control mode:	PR	
Unit:	-	Setting range:	0x00000000 - 0xFFFFFFFF	
Format:	HEX	Data size:	32-bit	

Settings:

Refer to the description of P6.002.

<b>P7.031</b>	<b>PATH 65 data</b>		<b>Address: 073EH 073FH</b>	
Default:	0	Control mode:	PR	
Unit:	-	Setting range:	-2147483648 to +2147483647	
Format:	DEC	Data size:	32-bit	

Settings:

Refer to the description of P6.003.

<b>P7.032</b>	<b>PATH 66 definition</b>		<b>Address: 0740H 0741H</b>	
Default:	0x00000000	Control mode:	PR	
Unit:	-	Setting range:	0x00000000 - 0xFFFFFFFF	
Format:	HEX	Data size:	32-bit	

Settings:

Refer to the description of P6.002.

<b>P7.033</b>	<b>PATH 66 data</b>		<b>Address: 0742H 0743H</b>	
Default:	0	Control mode:	PR	
Unit:	-	Setting range:	-2147483648 to +2147483647	
Format:	DEC	Data size:	32-bit	

Settings:

Refer to the description of P6.003.

<b>P7.034</b>	<b>PATH 67 definition</b>		<b>Address: 0744H 0745H</b>	
Default:	0x00000000	Control mode:	PR	
Unit:	-	Setting range:	0x00000000 - 0xFFFFFFFF	
Format:	HEX	Data size:	32-bit	

Settings:

Refer to the description of P6.002.

<b>P7.035</b>	<b>PATH 67 data</b>	<b>Address: 0746H 0747H</b>	
Default:	0	Control mode:	PR
Unit:	-	Setting range:	-2147483648 to +2147483647
Format:	DEC	Data size:	32-bit

Settings:

Refer to the description of P6.003.

<b>P7.036</b>	<b>PATH 68 definition</b>	<b>Address: 0748H 0749H</b>	
Default:	0x00000000	Control mode:	PR
Unit:	-	Setting range:	0x00000000 - 0xFFFFFFFF
Format:	HEX	Data size:	32-bit

Settings:

Refer to the description of P6.002.

<b>P7.037</b>	<b>PATH 68 data</b>	<b>Address: 074AH 074BH</b>	
Default:	0	Control mode:	PR
Unit:	-	Setting range:	-2147483648 to +2147483647
Format:	DEC	Data size:	32-bit

Settings:

Refer to the description of P6.003.

<b>P7.038</b>	<b>PATH 69 definition</b>	<b>Address: 074CH 074DH</b>	
Default:	0x00000000	Control mode:	PR
Unit:	-	Setting range:	0x00000000 - 0xFFFFFFFF
Format:	HEX	Data size:	32-bit

Settings:

Refer to the description of P6.002.

<b>P7.039</b>	<b>PATH 69 data</b>	<b>Address: 074EH 074FH</b>	
Default:	0	Control mode:	PR
Unit:	-	Setting range:	-2147483648 to +2147483647
Format:	DEC	Data size:	32-bit

Settings:

Refer to the description of P6.003.

8

<b>P7.040</b>	<b>PATH 70 definition</b>		<b>Address: 0750H 0751H</b>	
Default:	0x00000000	Control mode:	PR	
Unit:	-	Setting range:	0x00000000 - 0xFFFFFFFF	
Format:	HEX	Data size:	32-bit	

Settings:

Refer to the description of P6.002.

<b>P7.041</b>	<b>PATH 70 data</b>		<b>Address: 0752H 0753H</b>	
Default:	0	Control mode:	PR	
Unit:	-	Setting range:	-2147483648 to +2147483647	
Format:	DEC	Data size:	32-bit	

Settings:

Refer to the description of P6.003.

<b>P7.042</b>	<b>PATH 71 definition</b>		<b>Address: 0754H 0755H</b>	
Default:	0x00000000	Control mode:	PR	
Unit:	-	Setting range:	0x00000000 - 0xFFFFFFFF	
Format:	HEX	Data size:	32-bit	

Settings:

Refer to the description of P6.002.

<b>P7.043</b>	<b>PATH 71 data</b>		<b>Address: 0756H 0757H</b>	
Default:	0	Control mode:	PR	
Unit:	-	Setting range:	-2147483648 to +2147483647	
Format:	DEC	Data size:	32-bit	

Settings:

Refer to the description of P6.003.

<b>P7.044</b>	<b>PATH 72 definition</b>		<b>Address: 0758H 0759H</b>	
Default:	0x00000000	Control mode:	PR	
Unit:	-	Setting range:	0x00000000 - 0xFFFFFFFF	
Format:	HEX	Data size:	32-bit	

Settings:

Refer to the description of P6.002.

<b>P7.045</b>	<b>PATH 72 data</b>	<b>Address: 075AH 075BH</b>	
Default:	0	Control mode:	PR
Unit:	-	Setting range:	-2147483648 to +2147483647
Format:	DEC	Data size:	32-bit

Settings:

Refer to the description of P6.003.

<b>P7.046</b>	<b>PATH 73 definition</b>	<b>Address: 075CH 075DH</b>	
Default:	0x00000000	Control mode:	PR
Unit:	-	Setting range:	0x00000000 - 0xFFFFFFFF
Format:	HEX	Data size:	32-bit

Settings:

Refer to the description of P6.002.

<b>P7.047</b>	<b>PATH 73 data</b>	<b>Address: 075EH 075FH</b>	
Default:	0	Control mode:	PR
Unit:	-	Setting range:	-2147483648 to +2147483647
Format:	DEC	Data size:	32-bit

Settings:

Refer to the description of P6.003.

<b>P7.048</b>	<b>PATH 74 definition</b>	<b>Address: 0760H 0761H</b>	
Default:	0x00000000	Control mode:	PR
Unit:	-	Setting range:	0x00000000 - 0xFFFFFFFF
Format:	HEX	Data size:	32-bit

Settings:

Refer to the description of P6.002.

<b>P7.049</b>	<b>PATH 74 data</b>	<b>Address: 0762H 0763H</b>	
Default:	0	Control mode:	PR
Unit:	-	Setting range:	-2147483648 to +2147483647
Format:	DEC	Data size:	32-bit

Settings:

Refer to the description of P6.003.

8

<b>P7.050</b>	<b>PATH 75 definition</b>		<b>Address: 0764H 0765H</b>	
Default:	0x00000000	Control mode:	PR	
Unit:	-	Setting range:	0x00000000 - 0xFFFFFFFF	
Format:	HEX	Data size:	32-bit	

Settings:

Refer to the description of P6.002.

<b>P7.051</b>	<b>PATH 75 data</b>		<b>Address: 0766H 0767H</b>	
Default:	0	Control mode:	PR	
Unit:	-	Setting range:	-2147483648 to +2147483647	
Format:	DEC	Data size:	32-bit	

Settings:

Refer to the description of P6.003.

<b>P7.052</b>	<b>PATH 76 definition</b>		<b>Address: 0768H 0769H</b>	
Default:	0x00000000	Control mode:	PR	
Unit:	-	Setting range:	0x00000000 - 0xFFFFFFFF	
Format:	HEX	Data size:	32-bit	

Settings:

Refer to the description of P6.002.

<b>P7.053</b>	<b>PATH 76 data</b>		<b>Address: 076AH 076BH</b>	
Default:	0	Control mode:	PR	
Unit:	-	Setting range:	-2147483648 to +2147483647	
Format:	DEC	Data size:	32-bit	

Settings:

Refer to the description of P6.003.

<b>P7.054</b>	<b>PATH 77 definition</b>		<b>Address: 076CH 076DH</b>	
Default:	0x00000000	Control mode:	PR	
Unit:	-	Setting range:	0x00000000 - 0xFFFFFFFF	
Format:	HEX	Data size:	32-bit	

Settings:

Refer to the description of P6.002.

<b>P7.055</b>	<b>PATH 77 data</b>	<b>Address: 076EH 076FH</b>	
Default:	0	Control mode:	PR
Unit:	-	Setting range:	-2147483648 to +2147483647
Format:	DEC	Data size:	32-bit

Settings:

Refer to the description of P6.003.

<b>P7.056</b>	<b>PATH 78 definition</b>	<b>Address: 0770H 0771H</b>	
Default:	0x00000000	Control mode:	PR
Unit:	-	Setting range:	0x00000000 - 0xFFFFFFFF
Format:	HEX	Data size:	32-bit

Settings:

Refer to the description of P6.002.

<b>P7.057</b>	<b>PATH 78 data</b>	<b>Address: 0772H 0773H</b>	
Default:	0	Control mode:	PR
Unit:	-	Setting range:	-2147483648 to +2147483647
Format:	DEC	Data size:	32-bit

Settings:

Refer to the description of P6.003.

<b>P7.058</b>	<b>PATH 79 definition</b>	<b>Address: 0774H 0775H</b>	
Default:	0x00000000	Control mode:	PR
Unit:	-	Setting range:	0x00000000 - 0xFFFFFFFF
Format:	HEX	Data size:	32-bit

Settings:

Refer to the description of P6.002.

<b>P7.059</b>	<b>PATH 79 data</b>	<b>Address: 0776H 0777H</b>	
Default:	0	Control mode:	PR
Unit:	-	Setting range:	-2147483648 to +2147483647
Format:	DEC	Data size:	32-bit

Settings:

Refer to the description of P6.003.

8

<b>P7.060</b>	<b>PATH 80 definition</b>		<b>Address: 0778H 0779H</b>	
Default:	0x00000000	Control mode:	PR	
Unit:	-	Setting range:	0x00000000 - 0xFFFFFFFF	
Format:	HEX	Data size:	32-bit	

Settings:

Refer to the description of P6.002.

<b>P7.061</b>	<b>PATH 80 data</b>		<b>Address: 077AH 077BH</b>	
Default:	0	Control mode:	PR	
Unit:	-	Setting range:	-2147483648 to +2147483647	
Format:	DEC	Data size:	32-bit	

Settings:

Refer to the description of P6.003.

<b>P7.062</b>	<b>PATH 81 definition</b>		<b>Address: 077CH 077DH</b>	
Default:	0x00000000	Control mode:	PR	
Unit:	-	Setting range:	0x00000000 - 0xFFFFFFFF	
Format:	HEX	Data size:	32-bit	

Settings:

Refer to the description of P6.002.

<b>P7.063</b>	<b>PATH 81 data</b>		<b>Address: 077EH 077FH</b>	
Default:	0	Control mode:	PR	
Unit:	-	Setting range:	-2147483648 to +2147483647	
Format:	DEC	Data size:	32-bit	

Settings:

Refer to the description of P6.003.

<b>P7.064</b>	<b>PATH 82 definition</b>		<b>Address: 0780H 0781H</b>	
Default:	0x00000000	Control mode:	PR	
Unit:	-	Setting range:	0x00000000 - 0xFFFFFFFF	
Format:	HEX	Data size:	32-bit	

Settings:

Refer to the description of P6.002.

<b>P7.065</b>	<b>PATH 82 data</b>	<b>Address: 0782H 0783H</b>	
Default:	0	Control mode:	PR
Unit:	-	Setting range:	-2147483648 to +2147483647
Format:	DEC	Data size:	32-bit

Settings:

Refer to the description of P6.003.

<b>P7.066</b>	<b>PATH 83 definition</b>	<b>Address: 0784H 0785H</b>	
Default:	0x00000000	Control mode:	PR
Unit:	-	Setting range:	0x00000000 - 0xFFFFFFFF
Format:	HEX	Data size:	32-bit

Settings:

Refer to the description of P6.002.

<b>P7.067</b>	<b>PATH 83 data</b>	<b>Address: 0786H 0787H</b>	
Default:	0	Control mode:	PR
Unit:	-	Setting range:	-2147483648 to +2147483647
Format:	DEC	Data size:	32-bit

Settings:

Refer to the description of P6.003.

<b>P7.068</b>	<b>PATH 84 definition</b>	<b>Address: 0788H 0789H</b>	
Default:	0x00000000	Control mode:	PR
Unit:	-	Setting range:	0x00000000 - 0xFFFFFFFF
Format:	HEX	Data size:	32-bit

Settings:

Refer to the description of P6.002.

<b>P7.069</b>	<b>PATH 84 data</b>	<b>Address: 078AH 078BH</b>	
Default:	0	Control mode:	PR
Unit:	-	Setting range:	-2147483648 to +2147483647
Format:	DEC	Data size:	32-bit

Settings:

Refer to the description of P6.003.



8

<b>P7.070</b>	<b>PATH 85 definition</b>		<b>Address: 078CH 078DH</b>	
Default:	0x00000000	Control mode:	PR	
Unit:	-	Setting range:	0x00000000 - 0xFFFFFFFF	
Format:	HEX	Data size:	32-bit	

Settings:

Refer to the description of P6.002.

<b>P7.071</b>	<b>PATH 85 data</b>		<b>Address: 078EH 078FH</b>	
Default:	0	Control mode:	PR	
Unit:	-	Setting range:	-2147483648 to +2147483647	
Format:	DEC	Data size:	32-bit	

Settings:

Refer to the description of P6.003.

<b>P7.072</b>	<b>PATH 86 definition</b>		<b>Address: 0790H 0791H</b>	
Default:	0x00000000	Control mode:	PR	
Unit:	-	Setting range:	0x00000000 - 0xFFFFFFFF	
Format:	HEX	Data size:	32-bit	

Settings:

Refer to the description of P6.002.

<b>P7.073</b>	<b>PATH 86 data</b>		<b>Address: 0792H 0793H</b>	
Default:	0	Control mode:	PR	
Unit:	-	Setting range:	-2147483648 to +2147483647	
Format:	DEC	Data size:	32-bit	

Settings:

Refer to the description of P6.003.

<b>P7.074</b>	<b>PATH 87 definition</b>		<b>Address: 0794H 0795H</b>	
Default:	0x00000000	Control mode:	PR	
Unit:	-	Setting range:	0x00000000 - 0xFFFFFFFF	
Format:	HEX	Data size:	32-bit	

Settings:

Refer to the description of P6.002.

<b>P7.075</b>	<b>PATH 87 data</b>	<b>Address: 0796H 0797H</b>	
Default:	0	Control mode:	PR
Unit:	-	Setting range:	-2147483648 to +2147483647
Format:	DEC	Data size:	32-bit

Settings:

Refer to the description of P6.003.

<b>P7.076</b>	<b>PATH 88 definition</b>	<b>Address: 0798H 0799H</b>	
Default:	0x00000000	Control mode:	PR
Unit:	-	Setting range:	0x00000000 - 0xFFFFFFFF
Format:	HEX	Data size:	32-bit

Settings:

Refer to the description of P6.002.

<b>P7.077</b>	<b>PATH 88 data</b>	<b>Address: 079AH 079BH</b>	
Default:	0	Control mode:	PR
Unit:	-	Setting range:	-2147483648 to +2147483647
Format:	DEC	Data size:	32-bit

Settings:

Refer to the description of P6.003.

<b>P7.078</b>	<b>PATH 89 definition</b>	<b>Address: 079CH 079DH</b>	
Default:	0x00000000	Control mode:	PR
Unit:	-	Setting range:	0x00000000 - 0xFFFFFFFF
Format:	HEX	Data size:	32-bit

Settings:

Refer to the description of P6.002.

<b>P7.079</b>	<b>PATH 89 data</b>	<b>Address: 079EH 079FH</b>	
Default:	0	Control mode:	PR
Unit:	-	Setting range:	-2147483648 to +2147483647
Format:	DEC	Data size:	32-bit

Settings:

Refer to the description of P6.003.

8

<b>P7.080</b>	<b>PATH 90 definition</b>		<b>Address: 07A0H 07A1H</b>	
Default:	0x00000000	Control mode:	PR	
Unit:	-	Setting range:	0x00000000 - 0xFFFFFFFF	
Format:	HEX	Data size:	32-bit	

Settings:

Refer to the description of P6.002.

<b>P7.081</b>	<b>PATH 90 data</b>		<b>Address: 07A2H 07A3H</b>	
Default:	0	Control mode:	PR	
Unit:	-	Setting range:	-2147483648 to +2147483647	
Format:	DEC	Data size:	32-bit	

Settings:

Refer to the description of P6.003.

<b>P7.082</b>	<b>PATH 91 definition</b>		<b>Address: 07A4H 07A5H</b>	
Default:	0x00000000	Control mode:	PR	
Unit:	-	Setting range:	0x00000000 - 0xFFFFFFFF	
Format:	HEX	Data size:	32-bit	

Settings:

Refer to the description of P6.002.

<b>P7.083</b>	<b>PATH 91 data</b>		<b>Address: 07A6H 07A7H</b>	
Default:	0	Control mode:	PR	
Unit:	-	Setting range:	-2147483648 to +2147483647	
Format:	DEC	Data size:	32-bit	

Settings:

Refer to the description of P6.003.

<b>P7.084</b>	<b>PATH 92 definition</b>		<b>Address: 07A8H 07A9H</b>	
Default:	0x00000000	Control mode:	PR	
Unit:	-	Setting range:	0x00000000 - 0xFFFFFFFF	
Format:	HEX	Data size:	32-bit	

Settings:

Refer to the description of P6.002.

<b>P7.085</b>	<b>PATH 92 data</b>	<b>Address: 07AAH 07ABH</b>	
Default:	0	Control mode:	PR
Unit:	-	Setting range:	-2147483648 to +2147483647
Format:	DEC	Data size:	32-bit

Settings:

Refer to the description of P6.003.

<b>P7.086</b>	<b>PATH 93 definition</b>	<b>Address: 07ACH 07ADH</b>	
Default:	0x00000000	Control mode:	PR
Unit:	-	Setting range:	0x00000000 - 0xFFFFFFFF
Format:	HEX	Data size:	32-bit

Settings:

Refer to the description of P6.002.

<b>P7.087</b>	<b>PATH 93 data</b>	<b>Address: 07AEH 07AFH</b>	
Default:	0	Control mode:	PR
Unit:	-	Setting range:	-2147483648 to +2147483647
Format:	DEC	Data size:	32-bit

Settings:

Refer to the description of P6.003.

<b>P7.088</b>	<b>PATH 94 definition</b>	<b>Address: 07B0H 07B1H</b>	
Default:	0x00000000	Control mode:	PR
Unit:	-	Setting range:	0x00000000 - 0xFFFFFFFF
Format:	HEX	Data size:	32-bit

Settings:

Refer to the description of P6.002.

<b>P7.089</b>	<b>PATH 94 data</b>	<b>Address: 07B2H 07B3H</b>	
Default:	0	Control mode:	PR
Unit:	-	Setting range:	-2147483648 to +2147483647
Format:	DEC	Data size:	32-bit

Settings:

Refer to the description of P6.003.

8

<b>P7.090</b>	<b>PATH 95 definition</b>		<b>Address: 07B4H 07B5H</b>	
Default:	0x00000000	Control mode:	PR	
Unit:	-	Setting range:	0x00000000 - 0xFFFFFFFF	
Format:	HEX	Data size:	32-bit	

Settings:

Refer to the description of P6.002.

<b>P7.091</b>	<b>PATH 95 data</b>		<b>Address: 07B6H 07B7H</b>	
Default:	0	Control mode:	PR	
Unit:	-	Setting range:	-2147483648 to +2147483647	
Format:	DEC	Data size:	32-bit	

Settings:

Refer to the description of P6.003.

<b>P7.092</b>	<b>PATH 96 definition</b>		<b>Address: 07B8H 07B9H</b>	
Default:	0x00000000	Control mode:	PR	
Unit:	-	Setting range:	0x00000000 - 0xFFFFFFFF	
Format:	HEX	Data size:	32-bit	

Settings:

Refer to the description of P6.002.

<b>P7.093</b>	<b>PATH 96 data</b>		<b>Address: 07BAH 07BBH</b>	
Default:	0	Control mode:	PR	
Unit:	-	Setting range:	-2147483648 to +2147483647	
Format:	DEC	Data size:	32-bit	

Settings:

Refer to the description of P6.003.

<b>P7.094</b>	<b>PATH 97 definition</b>		<b>Address: 07BCH 07BDH</b>	
Default:	0x00000000	Control mode:	PR	
Unit:	-	Setting range:	0x00000000 - 0xFFFFFFFF	
Format:	HEX	Data size:	32-bit	

Settings:

Refer to the description of P6.002.

<b>P7.095</b>	<b>PATH 97 data</b>	<b>Address: 07BEH 07BFH</b>	
Default:	0	Control mode:	PR
Unit:	-	Setting range:	-2147483648 to +2147483647
Format:	DEC	Data size:	32-bit

Settings:

Refer to the description of P6.003.

<b>P7.096</b>	<b>PATH 98 definition</b>	<b>Address: 07C0H 07C1H</b>	
Default:	0x00000000	Control mode:	PR
Unit:	-	Setting range:	0x00000000 - 0xFFFFFFFF
Format:	HEX	Data size:	32-bit

Settings:

Refer to the description of P6.002.

<b>P7.097</b>	<b>PATH 98 data</b>	<b>Address: 07C2H 07C3H</b>	
Default:	0	Control mode:	PR
Unit:	-	Setting range:	-2147483648 to +2147483647
Format:	DEC	Data size:	32-bit

Settings:

Refer to the description of P6.003.

<b>P7.098</b>	<b>PATH 99 definition</b>	<b>Address: 07C4H 07C5H</b>	
Default:	0x00000000	Control mode:	PR
Unit:	-	Setting range:	0x00000000 - 0xFFFFFFFF
Format:	HEX	Data size:	32-bit

Settings:

Refer to the description of P6.002.

<b>P7.099</b>	<b>PATH 99 data</b>	<b>Address: 07C6H 07C7H</b>	
Default:	0	Control mode:	PR
Unit:	-	Setting range:	-2147483648 to +2147483647
Format:	DEC	Data size:	32-bit

Settings:

Refer to the description of P6.003.

## 8

**PM.xxx Motor parameters**

<b>PM.000 ▲ ●</b>	<b>Motor type</b>		<b>Address: FD00H FD01H</b>	
Default:	0	Control mode:	All	
Unit:	-	Setting range:	0 to 3	
Format:	DEC	Data size:	16-bit	

Settings:

Value	Motor type
0	Permanent-magnet synchronous rotary motor (SPM)
1	Reserved
2	Permanent-magnet synchronous linear motor (LM)
3	Reserved

<b>PM.001 ▲ ■</b>	<b>Motor parameter automatic identification function</b>		<b>Address: FD02H FD03H</b>	
Default:	0	Applicable motor:	All	
Unit:	-	Setting range:	0 to 1	
Format:	DEC	Data size:	16-bit	

Settings:

0: disable

1: enable

Note: this parameter is invalid if you are using a Delta communication type rotary motor.

<b>PM.002 ▲ ●</b>	<b>Motor parameter identification status</b>		<b>Address: FD04H FD05H</b>	
Default:	0	Applicable motor:	All	
Unit:	-	Setting range:	0 to 1	
Format:	DEC	Data size:	16-bit	

Settings:

0: motor parameter identification is not yet complete.

1: motor parameter identification is complete.

After executing motor parameter identification, the servo drive automatically detects whether the identification is complete. Use this parameter to obtain the motor parameter identification status.

When the motor parameter identification process has not been completed, if you switch the servo to the Servo On state, AL053 occurs to warn that the motor parameter identification is not yet complete. This parameter is automatically set to 1 when the motor parameter automatic identification is complete.

If you do not execute the motor parameter identification process, complete the related parameter settings for third-party motors, and then set this parameter to 1.

The servo drive automatically detects the identification status and inputs this parameter after executing the motor parameter identification process.

Note: this parameter value is always 1 and unchangeable if you are using a Delta rotary motor.

<b>PM.003 ▲ ●</b>	<b>Encoder type</b>		<b>Address: FD06H FD07H</b>
Default:	0x0010	Applicable motor:	All
Unit:	-	Setting range:	0x0000 - 0x1312
Format:	HEX	Data size:	16-bit

Settings:



X	CN2 signal type	Z	Converter box ABZ pulse filter
Y	Hall sensor	U	Main encoder signal source

- X: CN2 signal type<sup>\*2</sup>
  - 0: pulse digital signal
  - 1: sine wave analog signal
  - 2: pulse digital signal - dedicated for Delta motor with magnetic encoder (ECMA-C8)
  
- Y: Hall sensor
  - 0: no Hall sensor
  - 1: with Hall sensor

Important: if you set PM.003.Y to 0, the motor moves slightly to detect the magnetic pole when the servo is on for the first time. It is suggested that you execute the Z-axis magnetic field detection after installing the Hall sensor.
  
- Z: converter box ABZ pulse filter<sup>\*2</sup>
  - 0: bypass
  - 1: 16 MHz
  - 2: 8 MHz
  - 3: 3 MHz

Example: pulse width 16 MHz (62.5 ns)

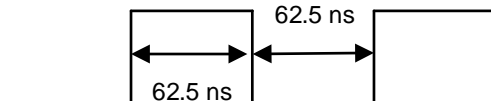

- U: main encoder signal source
  - 0: CN2
  - 1: CN5

Note:

1. This parameter is invalid if you are using a Delta communication type rotary motor.



2. To receive pulses or sine wave signals with CN2, use the Delta position signal converter box (ASD-IF-EN0A20).
3. When the Delta motor with magnetic encoder (ECMA-C8) is connected to the CN5 connector, there is not need to execute motor parameter identification. Simply set this parameter to 0x1002 and cycle the power.

## 8

PM.004 ▲ ●	Main encoder resolution	Address: FD08H FD09H	
Default:	-	Applicable motor:	All
Unit:	Rotary motor: Pulse signal: pulse/rev Sine wave signal: period/rev Communication type*: bit/rev Linear motor: Pulse signal: $10^{-3}$ $\mu\text{m}/\text{pulse}$ Sine wave signal: $10^{-3}$ $\mu\text{m}/\text{period}$ Communication type: $10^{-3}$ $\mu\text{m}/\text{pulse}$	Setting range:	Rotary motor: Pulse signal: 128 to $2^{28}$ Sine wave signal: 64 to $2^{30-\text{PM.005}}$ Communication type*: 7 to 30 Linear motor: Pulse signal: 1 to 30000 Sine wave signal: $2^{\text{PM.005}-1}$ to 200000 Communication type*: 1 to 30000
Format:	DEC	Data size:	32-bit

## Settings:

Set the resolution according to the encoder specifications.

When PM.003.U = 0, input the resolution of the encoder connected to CN2; when PM.003.U = 1, input the resolution of the encoder connected to CN5.

■ Rotary motor:

1. Pulse encoder: input the number of single-phase pulses per revolution; the resolution of the motor is  $(\text{PM.004} \times 4)$  pulse/rev.
2. Sine wave encoder: input the number of single-phase sine waves per revolution; the resolution of the motor is  $(\text{PM.004} \times 2^{\text{PM.005}})$  pulse/rev.
3. Communication type encoder: input the resolution according to the Motor Parameter Identification Wizard process.

■ Linear motor:

1. Pulse encoder: input the corresponding distance of the motor pulse after quadruple frequency; the resolution of the motor is  $(\text{PM.004} \times 0.001)$   $\mu\text{m}/\text{pulse}$ .
2. Sine wave encoder: input the corresponding distance of the motor single-phase sine wave; the resolution of the motor is  $(\text{PM.004} \times 0.001 / 2^{\text{PM.005}})$   $\mu\text{m}/\text{pulse}$ .
3. Communication type encoder: input the resolution according to the Motor Parameter Identification Wizard process.

Note: communication type indicates communication formats of encoders of other brands that are supported by ASDA-A3, such as BiSS C, Mitutoyo, Endat2.2, Fagor, Tamagawa, and Nikon.

<b>PM.005</b>	<b>Position signal converter box interpolation magnification</b>		<b>Address: FD0AH FD0BH</b>
Default:	11	Applicable motor:	Linear motor, third-party rotary motor
Unit:	-	Setting range:	2 - 11
Format:	DEC	Data size:	16-bit

Settings:

This parameter improves the motor resolution with interpolation magnification. It is applicable to sine wave encoders and not applicable to pulse encoders.

The resolution of the sine wave encoder after interpolation is  $PM.004 \times 2^N$ ;  $N = PM.005$ .

<b>PM.006 ▲ ●</b>	<b>Motor UVW and Hall sensor phase sequences</b>		<b>Address: FD0CH FD0DH</b>
Default:	0x0000	Applicable motor:	Linear motor, third-party rotary motor
Unit:	-	Setting range:	0x0000 - 0x0011
Format:	HEX	Data size:	16-bit

Settings:

During the motor parameter identification process, the servo drive automatically detects the phase sequences of the motor UVW and Hall sensor. You can use this parameter to obtain this information.

- X: motor UVW phase sequence and encoder incremental direction
  - 0: when A phase is ahead of B phase, the motor phase sequence is U, V, and W.
  - 1: when A phase is ahead of B phase, the motor phase sequence is U, W, and V.

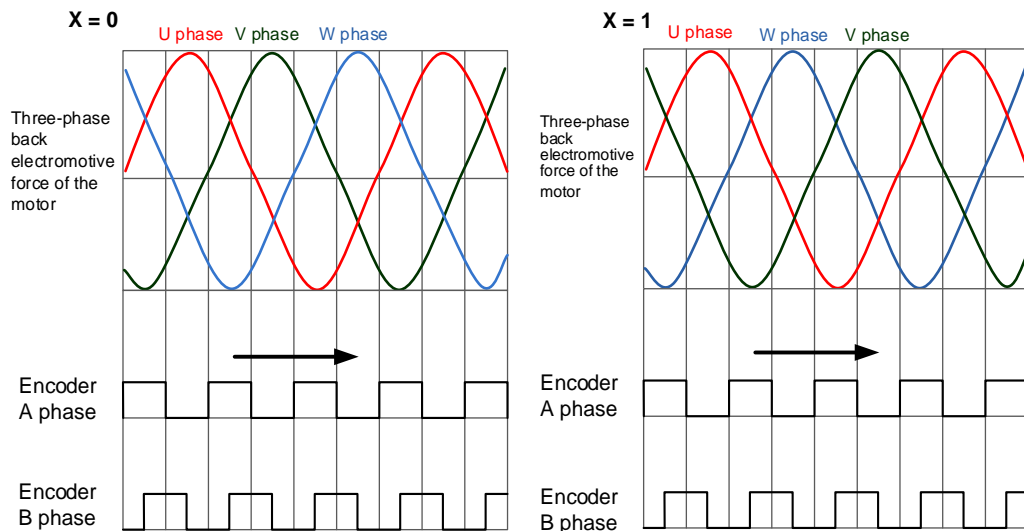

8

- Y: motor UVW phase sequence and Hall sensor UVW direction
- 0: when the Hall sensor phase sequence is U, V, and W, the motor phase sequence is U, V, and W.
- 1: when the Hall sensor phase sequence is U, V, and W, the motor phase sequence is U, W, and V.

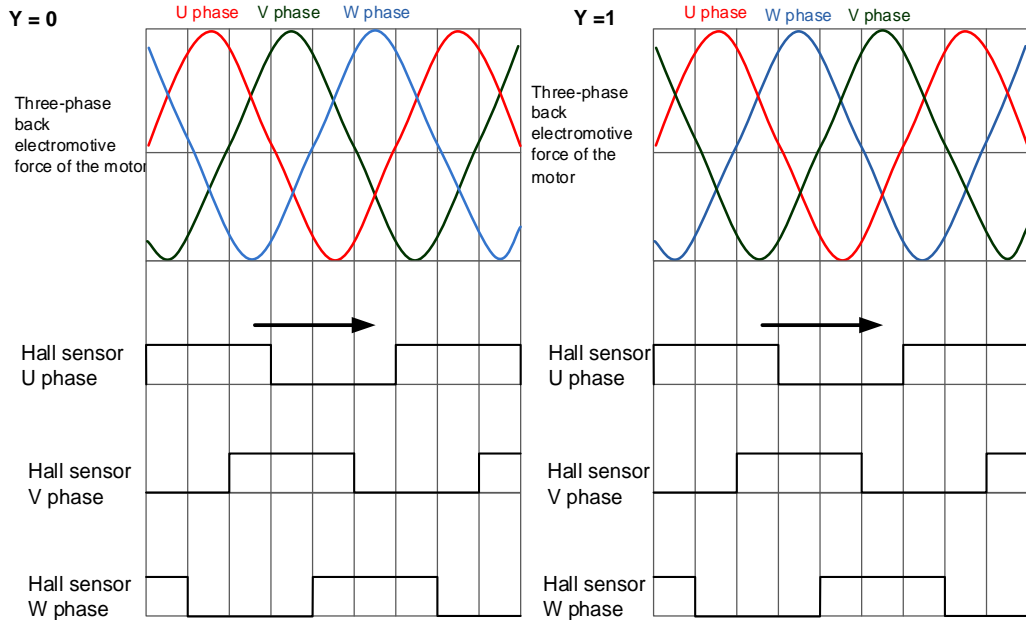

PM.007 ▲ ●	Hall sensor offset angle		Address: FD0EH FD0FH
Default:	0.0	Applicable motor:	All
Unit:	Degree	Setting range:	0 to 360.0
Format:	DEC	Data size:	16-bit

Settings:

During the motor parameter identification process, the servo drive automatically detects the offset angle of the Hall sensor. You can use this parameter to obtain this information.

When the Hall sensor causes hysteresis due to different motion directions of the motor, the U-phase zero point of the Hall sensor is based on the central angle of the hysteresis. For the description of hysteresis, refer to the diagram of PM.008.

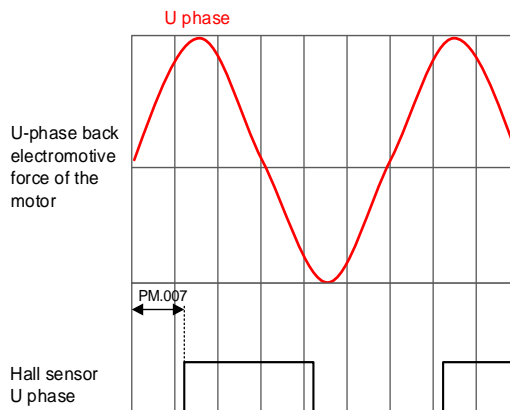

<b>PM.008 ▲ ●</b>	<b>Hall sensor hysteresis width</b>		<b>Address: FD10H FD11H</b>
Default:	0.0	Applicable motor:	All
Unit:	Degree	Setting range:	0 to 360.0
Format:	DEC	Data size:	16-bit

Settings:

During the motor parameter identification process, the servo drive automatically detects the hysteresis width of the Hall sensor. You can use this parameter to obtain this information.

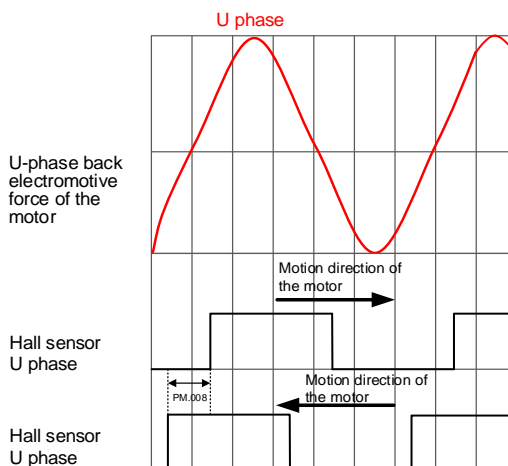

<b>PM.009 ▲</b>	<b>Electrical angle settings</b>		<b>Address: FD12H FD13H</b>
Default:	0x0000	Applicable motor:	Linear motor, third-party rotary motor
Unit:	-	Setting range:	0x0000 - 0xFFFF
Format:	HEX	Data size:	16-bit

Settings:

Bit	7	6	5	4	3	2	1	0
Bit	15	14	13	12	11	10	9	8

Bit	Function	Description
Bit 0	Reserved	-
Bit 1	Magnetic field detection after powering on	Magnetic field detection after the absolute encoder is powered on (cycle the power for this setting to take effect) 0: after the absolute encoder is powered on, the initial magnetic field angle is determined by PM.010. 1: after the absolute encoder is powered on, the initial magnetic field angle is determined by the initial magnetic field detection function (PM.012).
Bit 2	Detect the number of magnetic poles	Set whether to use the automatic detection of the number of magnetic poles when executing the motor parameter identification process for the third-party rotary motor. 0: automatic detection of the number of magnetic poles 1: no detection of the number of magnetic poles. Manually input the number of magnetic poles to PM.028 Permanent-magnet rotary motor pole number.
Bit 3	Reserved	-

## 8

Bit	Function	Description
Bit 4	Use the Hall sensor to determine whether the motor magnetic field is deviated	Use the Hall sensor to determine whether the motor magnetic field is deviated 0: disable 1: enable If the deviation between the magnetic field detected by the Hall sensor and the actual magnetic field of the motor is too large, AL055 Motor magnetic field error occurs.
Bit 5	Select the signal source for the Hall sensor when the signal source of the main encoder is CN2	Hall sensor signal source selection when PM.003.U = 0 (Main encoder signal source is CN2). 0: CN2 1: CN5
Bit 6 - Bit 15	Reserved	-

PM.010 ▲ ●	Offset between absolute encoder zero point and motor magnetic field zero point		Address: FD14H FD15H
Default:	180.0	Applicable motor:	Absolute motor
Unit:	Degree	Setting range:	0 to 360.0
Format:	DEC	Data size:	16-bit

Settings:

The accumulated angle starting from the motor magnetic field zero point to the absolute encoder zero point with the motor rotating in the positive (CCW) direction (positive phase sequence).

This parameter value will be automatically detected and input during the motor parameter identification process.

PM.011 ▲	Current setting for initial magnetic field detection		Address: FD16H FD17H
Default:	100	Applicable motor:	Linear motor, third-party rotary motor
Unit:	%	Setting range:	0 to 250
Format:	DEC	Data size:	16-bit

Settings:

If the motor is not installed with a Hall sensor, the servo drive will automatically detect the motor magnetic field when the servo is switched to On for the first time. Use this parameter to set the current value during the motor magnetic field detection. If you are using a Hall sensor (PM.003 = 1), you do not need to set this parameter.

The current affects the motion range of the motor during magnetic field detection, and the servo obtains the magnetic field data through the motion.

Note the following when setting this parameter:

1. When the friction between the motor and the mechanical parts is too large, magnetic field detection error may occur which triggers AL052. Increase the set value of this parameter can reduce the occurrence of AL052.
2. When the motor moves too much, lower the set value of this parameter to reduce the motion range during magnetic field detection.

Note:

1. It is suggested that you do not use the initial magnetic field detection for Z axis. Install a Hall sensor to Z axis for magnetic field detection.
2. The gantry application requires a Hall sensor for magnetic field detection. Thus, using this function is not suggested.

<b>PM.012 ▲</b>	<b>Initial magnetic field detection</b>		<b>Address: FD18H FD19H</b>
Default:	0x0044	Applicable motor:	Linear motor, third-party rotary motor
Unit:	-	Setting range:	0x0011- 0xFFFF
Format:	HEX	Data size:	16-bit

Settings:



X	Initial magnetic field detection condition 1	Z	Initial magnetic field detection delay time
Y	Initial magnetic field detection condition 2	U	Special function

X: initial magnetic field detection condition 1

Value	1	2	3	4	5	6	7	8
Electrical angle	0.25	0.5	0.75	1	1.25	1.5	1.75	2
Value	9	A	B	C	D	E	F	-
Electrical angle	2.25	2.5	2.75	3	3.25	3.5	3.75	-

Y: initial magnetic field detection condition 2

Value	1	2	3	4	5	6	7	8
Electrical angle	10	20	30	40	50	60	70	80
Value	9	A	B	C	D	E	F	-
Electrical angle	90	100	110	120	130	140	150	-

Z: initial magnetic field detection delay time

When the servo is switched to Servo On for the first time, the initial magnetic field detection starts after this set delay time.

Value	0	1	2	3	4	5	6	7
Time (ms)	0	50	100	150	200	250	300	350
Value	8	9	A	B	C	D	E	F
Time (ms)	400	450	550	650	750	850	950	1050

U: special function

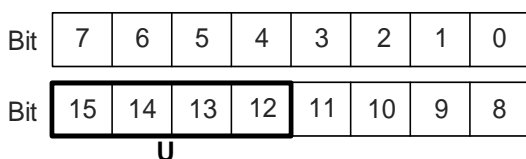

Bit	Function	Description
Bit 12, Bit 13	Initial magnetic field detection for Z axis	<ul style="list-style-type: none"> <li>Before using this function, first set the initial magnetic field detection when power is on (Bit 14 and Bit 15) to <b>quick mode</b>.</li> <li>When executing parameter identification for the Z axis, place the translation stage under the mechanical part at a balanced position. Check for the mechanical limits, set this parameter, and then execute initial magnetic field detection, which leads to successful detection.</li> </ul> <p>Bit 13 = 0, Bit 12 = 0: disable this function.                      Bit 13 = 0, Bit 12 = 1: when the value of the motor feedback position [PUU] increases towards a positive value, the motor reaches the mechanical limit.                      Bit 13 = 1, Bit 12 = 0: when the value of the motor feedback position [PUU] decreases towards a negative value, the motor reaches the mechanical limit.</p>
Bit 14, Bit 15	Initial magnetic field detection when power is on	<ul style="list-style-type: none"> <li>The initial magnetic field detection is not available for motors with brakes.</li> <li>The smooth mode does not support the initial magnetic field detection for Z axis.</li> </ul> <p>Bit 15 = 0, Bit 14 = 0: quick mode; the motor moves significantly.                      Bit 15 = 0, Bit 14 = 1: smooth mode; the motor moves slightly.</p>

The usage of PM.012.U [Bit 14] is described as follows.

	PM.012.U [Bit 14] = 0	PM.012.U [Bit 14] = 1
Mode	Quick mode	Smooth mode
Motion of motor magnetic field	Great	Small
Detection time	Short	Long
Condition for judgment	When the initial magnetic field detection conditions 1 and 2 (PM.012.X and PM.012.Y) cannot be met at the same time, the servo starts the detection again. If the detection fails for 4 consecutive times, the servo displays AL052.	The mode only refers to the result of the initial magnetic field detection condition 1 (PM.012.X). If the detection fails for 10 consecutive times, the servo displays AL052.
Condition for successful detection	The motion of the motor magnetic field is greater than PM.012.X and the command controlling the magnetic field is greater than PM.012.Y.	The motion of the motor magnetic field is smaller than PM.012.X.
Condition setting	The default setting is recommended.	The default setting is recommended.
Important	If you are using a motor with a brake for the Z-axis mechanical part, using the initial magnetic field detection is prohibited. Use a Hall sensor or an absolute motor instead.	



PM.013 ▲ ●	Motor flag			Address: FD1AH FD1BH
Default:	0	Applicable motor:	All	
Unit:	-	Setting range:	0 to 1	
Format:	DEC	Data size:	16-bit	

## Settings:

When a linear motor or third-party motor is used, the servo drive automatically detects and writes the parameter identification status to this parameter after executing the motor parameter identification process. If you have not executed the motor parameter identification process, set this parameter to 1.

1. This parameter is automatically set to 0 when the Delta communication type motor is connected to CN2 and the communication is successful.
2. When you are not using a Delta communication type motor, set this parameter to 1. This parameter is automatically set to 1 when you execute the Motor Parameter Identification Wizard.

PM.014	Reserved
--------	----------

PM.015	Current loop proportional gain (kp)			Address: FD1EH FD1FH
Operation interface:	Panel / software	Communication	Applicable motor:	All
Default:	0.000	0	Data size:	32-bit
Unit:	1 rad/s	0.001 rad/s	-	-
Setting range:	Rotary motor: 0.000 to 1023.000 Linear motor: 0.000 to 16383.000	Rotary motor: 0 to 1023000 Linear motor: 0 to 16383000		
Format:	Three decimals	DEC		
Example:	1.5 = 1.5 rad/s	1500 = 1.5 rad/s		

## Settings:

You do not need to set this parameter when using a Delta communication type motor.

Increasing the current control gain can enhance the current response and reduce the current control errors. If you set the value too high, it may cause vibration and noise. It is suggested that general users do not adjust this parameter.

Note: rotary means a permanent-magnet synchronous rotary motor; linear means a permanent-magnet synchronous linear motor.



8

<b>PM.016</b>	<b>Current loop integral gain (ki)</b>		<b>Address: FD20H FD21H</b>
Default:	0	Applicable motor:	All
Unit:	%	Setting range:	0 to 32767
Format:	DEC	Data size:	16-bit

Settings:

You do not need to set this parameter when using a Delta communication type motor.

Increasing the current control integral can enhance the current response and reduce the current control errors. If you set the value too high, it may cause vibration and noise. It is suggested that general users do not adjust this parameter.

<b>PM.017 - PM.018</b>	<b>Reserved</b>
----------------------------	-----------------

<b>PM.019▲</b>	<b>Load increase gain</b>		<b>Address: FD26H FD27H</b>
Default:	100	Applicable motor:	All
Unit:	%	Setting range:	0 to 600
Format:	DEC	Data size:	16-bit

Settings:

Use this parameter to adjust the motor overload protection time. For the setting details, refer to the following table and figures.

Load ratio	Operating time	Load ratio	Operating time
0	12 sec x PM.020	260%	3.9 sec x PM.019
20%	12.3 sec x PM.020	280%	3.3 sec x PM.019
40%	13.6 sec x PM.020	300%	2.8 sec x PM.019
60%	16.3 sec x PM.020	320%	2.5 sec x PM.019
80%	22.6 sec x PM.020	340%	2.2 sec x PM.019
100%	N/A	360%	2.0 sec x PM.019
120%	263.8 sec x PM.019	380%	1.8 sec x PM.019
140%	35.2 sec x PM.019	400%	1.6 sec x PM.019
160%	17.6 sec x PM.019	420%	1.4 sec x PM.019
180%	11.2 sec x PM.019	440%	1.3 sec x PM.019
200%	8 sec x PM.019	460%	1.2 sec x PM.019
220%	6.1 sec x PM.019	480%	1.1 sec x PM.019
240%	4.8 sec x PM.019	500%	1 sec x PM.019

The operating time means the time required for the motor protection level to reach the overload level from the normal level. When the protection level reaches the overload level, AL006 is triggered. The measurement basis of the load ratio is 100%. When the ratio is above 100%, it refers to the load increase gain (PM.019); when the ratio is less than 100%, it refers to the load decrease gain (PM.020).

Example 1:

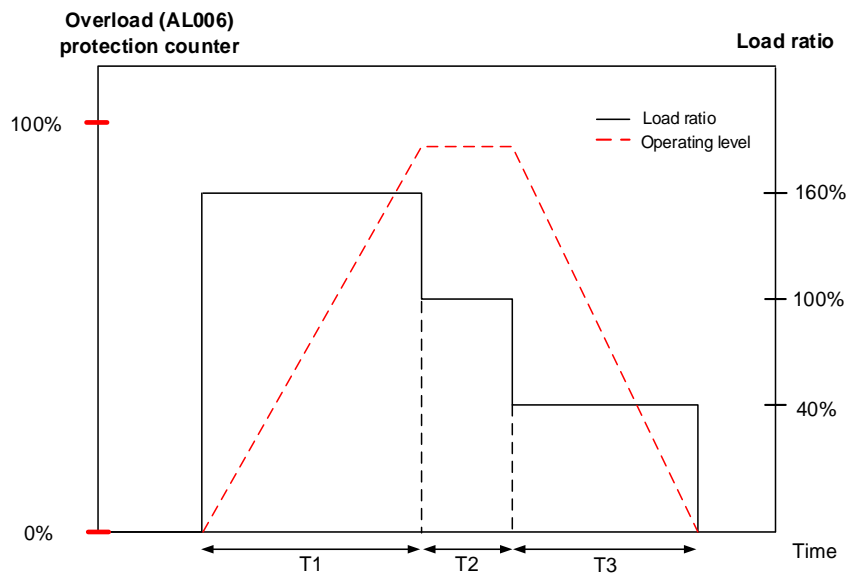

1. When the load ratio is 160%, the overload (AL006) protection counter continues to increase.
2. When the load ratio is 100%, the operating level is leveled off.
3. When the load ratio is 40%, the overload (AL006) protection counter continues to decrease.

Example 2:

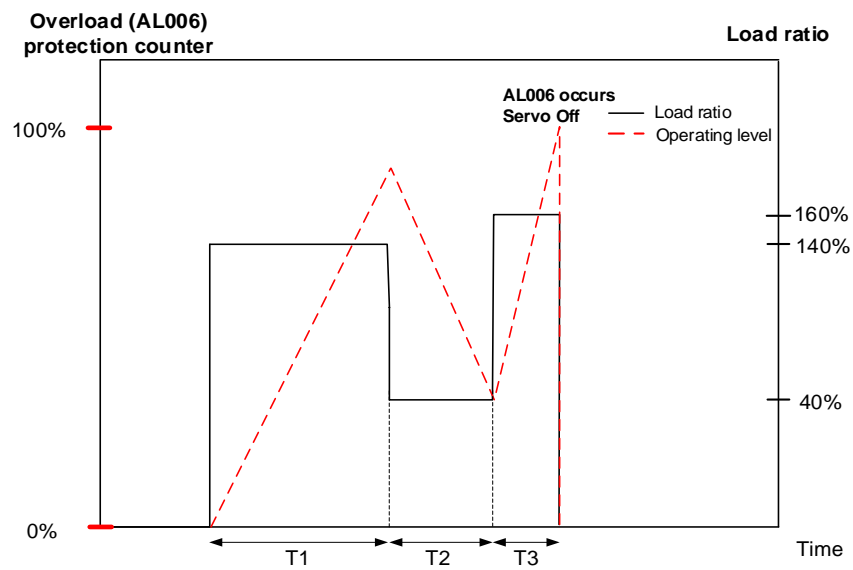

As shown in the preceding figure, the load ratio affects whether the load is accumulated. When the load accumulates over 100%, the operating time must be taken into consideration, or else AL006 occurs.

8

<b>PM.020 ▲</b>	<b>Load decrease gain</b>		<b>Address: FD28H FD29H</b>
Default:	100	Applicable motor:	All
Unit:	%	Setting range:	15 to 600
Format:	DEC	Data size:	16-bit

Settings:

This parameter setting affects the operating time of the load decrease and the overall motion planning.

Refer to the description of PM.019.

<b>PM.021</b>	<b>Reserved</b>
---------------	-----------------

<b>PM.022 ▲ ●</b>	<b>Motor temperature sensor</b>		<b>Address: FD2CH FD2DH</b>
Default:	0	Applicable motor:	Linear motor, third-party rotary motor
Unit:	-	Setting range:	0 to 3
Format:	DEC	Data size:	16-bit

Settings:

Sets the type of motor temperature sensor connected to the servo drive CN5 Pin 13 and Pin 14 (see Section 3.8).

0: a motor temperature sensor is not connected

1: Delta linear motor NTC thermistor

2: NTC level thermistor

3: PTC level thermistor

Note: when PM.022 = 1, you can check the temperature by setting the monitoring variable P0.002 to -145.

<b>PM.023</b>	<b>Reserved</b>
---------------	-----------------

<b>PM.024 ▲</b>	<b>Motor temperature sensor resistance</b>		<b>Address: FD30H FD31H</b>
Default:	50000	Applicable motor:	Linear motor, third-party rotary motor
Unit:	ohm	Setting range:	0 to 50000
Format:	DEC	Data size:	32-bit

Settings:

This parameter is only valid when PM.022 is set to 2 or 3. Set the resistance value corresponding to the protective temperature to this parameter. Refer to the NTC or PTC temperature and resistance value corresponding table for the resistance value.

<b>PM.025 - PM.027</b>	<b>Reserved</b>
----------------------------	-----------------

PM.028 ▲ ●	Permanent-magnet rotary motor pole number		Address: FD38H FD39H
Default:	10	Applicable motor:	Permanent-magnet rotary motor
Unit:	pole	Setting range:	2 to 100
Format:	DEC	Data size:	16-bit

Settings:

Input the correct value according to the specifications of the third-party permanent-magnet rotary motor.

Note: pole number = pole pair x 2

PM.029 ▲ ●	Permanent-magnet rotary motor rated current		Address: FD3AH FD3BH
Operation interface:	Panel / software	Communication	Applicable motor: Permanent-magnet rotary motor
Default:	-	-	Data size: 16-bit
Unit:	Arms	0.01 Arms	
Setting range:	0.00 to servo drive rated current	0 to servo drive rated current x 100	
Format:	Two decimals	DEC	
Example:	1.5 = 1.5 Arms	150 = 1.5 Arms	

Settings:

Input the correct value according to the specifications of the third-party permanent-magnet rotary motor.

Unit conversion between Ampere peak and Ampere RMS:

$$\text{Ampere peak (Apk)} = \text{Ampere RMS (Arms)} \times \sqrt{2}$$

PM.030 ▲ ●	Permanent-magnet rotary motor maximum current		Address: FD3CH FD3DH
Operation interface:	Panel / software	Communication	Applicable motor: Permanent-magnet rotary motor
Default:	-	-	Data size: 16-bit
Unit:	Arms	0.01 Arms	
Setting range:	0.00 to servo drive maximum current	0 to servo drive maximum current x 100	
Format:	Two decimals	DEC	
Example:	1.5 = 1.5 Arms	150 = 1.5 Arms	

Settings:

Input the correct value according to the specifications of the third-party permanent-magnet rotary motor.

Unit conversion between Ampere peak and Ampere RMS:

$$\text{Ampere peak (Apk)} = \text{Ampere RMS (Arms)} \times \sqrt{2}$$

8

PM.031 ▲	Permanent-magnet rotary motor rated speed			Address: FD3EH FD3FH
Default:	-	Applicable motor:	Permanent-magnet rotary motor	
Unit:	rpm	Setting range:	0 to 4000	
Format:	DEC	Data size:	16-bit	

Settings:

Input the correct value according to the specifications of the third-party permanent-magnet rotary motor.

PM.032 ▲	Permanent-magnet rotary motor maximum speed			Address: FD40H FD41H
Default:	-	Applicable motor:	Permanent-magnet rotary motor	
Unit:	rpm	Setting range:	0 to 7500	
Format:	DEC	Data size:	16-bit	

Settings:

Input the correct value according to the specifications of the third-party permanent-magnet rotary motor.

PM.033 ▲	Permanent-magnet rotary motor torque constant			Address: FD42H FD43H
Operation interface:	Panel / software	Communication	Applicable motor:	Permanent-magnet rotary motor
Default:	-	-	Data size:	32-bit
Unit:	Nm/Arms	0.001 Nm/Arms		
Setting range:	0.000 to 65.535	0 to 65535		
Format:	Three decimals	DEC		
Example:	1.5 = 1.5 Nm/Arms	1500 = 1.5 Nm/Arms		

Settings:

Input the correct value according to the specifications of the third-party permanent-magnet rotary motor.

PM.034 ▲	Permanent-magnet rotary motor rotor inertia			Address: FD44H FD45H
Operation interface:	Panel / software	Communication	Applicable motor:	Permanent-magnet rotary motor
Default:	-	-	Data size:	32-bit
Unit:	$10^{-4}$ kg·m <sup>2</sup>	$0.001 \times 10^{-4}$ kg·m <sup>2</sup>		
Setting range:	0.000 to 2147483.647	0 to 2147483647		
Format:	Three decimals	DEC		
Example:	1.5 = $1.5 \times 10^{-4}$ kg·m <sup>2</sup>	1500 = $1.5 \times 10^{-4}$ kg·m <sup>2</sup>		

Settings:

Input the correct value according to the specifications of the third-party permanent-magnet rotary motor.

<b>PM.035 ▲</b>	<b>Permanent-magnet rotary motor phase resistance</b>			<b>Address: FD46H FD47H</b>
Operation interface:	Panel / software	Communication	Applicable motor:	Permanent-magnet rotary motor
Default:	-	-	Data size:	32-bit
Unit:	ohm	0.001 ohm		
Setting range:	0.000 to 2000.000	0 to 2000000		
Format:	Three decimals	DEC		
Example:	1.5 = 1.5 ohm	1500 = 1.5 ohm		

Settings:

Input the correct value according to the specifications of the third-party permanent-magnet rotary motor.

<b>PM.036 ▲</b>	<b>Permanent-magnet rotary motor phase inductance</b>			<b>Address: FD48H FD49H</b>
Operation interface:	Panel / software	Communication	Applicable motor:	Permanent-magnet rotary motor
Default:	-	-	Data size:	32-bit
Unit:	mH	0.01 mH		
Setting range:	0.00 to 1000.00	0 to 100000		
Format:	Two decimals	DEC		
Example:	1.5 = 1.5 mH	150 = 1.5 mH		

Settings:

Input the correct value according to the specifications of the third-party permanent-magnet rotary motor.

<b>PM.037</b>	<b>Reserved</b>
---------------	-----------------

<b>PM.038 ▲</b>	<b>Permanent-magnet rotary motor back electromotive force constant</b>			<b>Address: FD4CH FD4DH</b>
Operation interface:	Panel / software	Communication	Applicable motor:	Permanent-magnet rotary motor
Default:	-	-	Data size:	32-bit
Unit:	Vrms/rpm	0.0001 Vrms/rpm		
Setting range:	0.0000 to 2.2876	0 to 22876		
Format:	Four decimals	DEC		
Example:	1.5 = 1.5 Vrms/rpm	15000 = 1.5 Vrms/rpm		

Settings:

Input the correct value according to the specifications of the third-party permanent-magnet rotary motor.

<b>PM.039 - PM.044</b>	<b>Reserved</b>
----------------------------	-----------------

8

PM.045 ▲ ●	Linear motor pole pitch (N-N)			Address: FD5AH FD5BH
Operation interface:	Panel / software	Communication	Applicable motor:	Linear motor
Default:	-	-	Data size:	32-bit
Unit:	mm/360° (mm/N-N)	0.001 mm/360° (0.001 mm/N-N)		
Setting range:	1.000 to 500.000	1000 to 500000		
Format:	Three decimals	DEC		
Example:	1.5 = 1.5 mm/360°	1500 = 1.5 mm/360°		

Settings:

Input the correct value according to the specifications of the linear motor.

PM.046 ▲ ●	Linear motor rated current			Address: FD5CH FD5DH
Operation interface:	Panel / software	Communication	Applicable motor:	Linear motor
Default:	-	-	Data size:	16-bit
Unit:	Arms	0.01 Arms		
Setting range:	0.00 to servo drive rated current	0 to servo drive rated current x 100		
Format:	Two decimals	DEC		
Example:	1.5 = 1.5 Arms	150 = 1.5 Arms		

Settings:

Input the correct value according to the specifications of the linear motor.

Unit conversion between Ampere peak and Ampere RMS:

$$\text{Ampere peak (Apk)} = \text{Ampere RMS (Arms)} \times \sqrt{2}$$

PM.047 ▲ ●	Linear motor maximum current			Address: FD5EH FD5FH
Operation interface:	Panel / software	Communication	Applicable motor:	Linear motor
Default:	-	-	Data size:	16-bit
Unit:	Arms	0.01 Arms		
Setting range:	0.00 to servo drive maximum current	0 to servo drive maximum current x 100		
Format:	Two decimals	DEC		
Example:	1.5 = 1.5 Arms	150 = 1.5 Arms		

Settings:

Input the correct value according to the specifications of the linear motor.

Unit conversion between Ampere peak and Ampere RMS:

$$\text{Ampere peak (Apk)} = \text{Ampere RMS (Arms)} \times \sqrt{2}$$

<b>PM.048 ▲</b>	<b>Linear motor maximum speed</b>			<b>Address: FD60H FD61H</b>
Default:	-	Applicable motor:	Linear motor	
Unit:	mm/s	Setting range:	0 to 15999	
Format:	DEC	Data size:	16-bit	

Settings:

Input the correct value according to the specifications of the linear motor.

<b>PM.049 ▲</b>	<b>Linear motor force constant</b>			<b>Address: FD62H FD63H</b>
Operation interface:	Panel / software	Communication	Applicable motor:	Linear motor
Default:	-	-	Data size:	32-bit
Unit:	N/Arms	0.01 N/Arms		
Setting range:	0.00 to 1773.62	0 to 177362		
Format:	Two decimals	DEC		
Example:	1.5 = 1.5 N/Arms	150 = 1.5 N/Arms		

Settings:

Input the correct value according to the specifications of the linear motor.

<b>PM.050 ▲</b>	<b>Linear motor phase resistance</b>			<b>Address: FD64H FD65H</b>
Operation interface:	Panel / software	Communication	Applicable motor:	Linear motor
Default:	-	-	Data size:	32-bit
Unit:	ohm	0.001 ohm		
Setting range:	0.000 to 2000.000	0 to 2000000		
Format:	Three decimals	DEC		
Example:	1.5 = 1.5 ohm	1500 = 1.5 ohm		

Settings:

Input the correct value according to the specifications of the linear motor.



8

<b>PM.051 ▲</b>	<b>Linear motor phase inductance</b>			<b>Address: FD66H FD67H</b>
Operation interface:	Panel / software	Communication	Applicable motor:	Linear motor
Default:	-	-	Data size:	32-bit
Unit:	mH	0.01 mH		
Setting range:	0.00 to 1000.00	0 to 100000		
Format:	Two decimals	DEC		
Example:	1.5 = 1.5 mH	150 = 1.5 mH		

Settings:

Input the correct value according to the specifications of the linear motor.

<b>PM.052</b>	<b>Reserved</b>
---------------	-----------------

<b>PM.053 ▲</b>	<b>Linear motor back electromotive force constant</b>			<b>Address: FD6AH FD6BH</b>
Operation interface:	Panel / software	Communication	Applicable motor:	Linear motor
Default:	-	-	Data size:	16-bit
Unit:	Vrms/(m/s)	0.1 Vrms/(m/s)		
Setting range:	0.0 to 591.2	0 to 5912		
Format:	One decimal	DEC		
Example:	1.5 = 1.5 Vrms/(m/s)	15 = 1.5 Vrms/(m/s)		

Settings:

Input the correct value according to the specifications of the linear motor.

<b>PM.054 - PM.063</b>	<b>Reserved</b>
----------------------------	-----------------

**Table 8.1 Digital input (DI) descriptions**

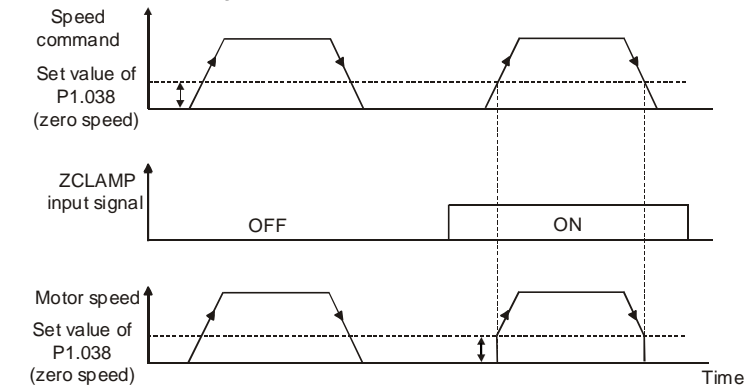
Value: 0x01			
DI name	Description	Triggering method	Control mode
SON	When this DI is on, servo is activated (Servo On).	Level triggered	All
Value: 0x02			
DI name	Description	Triggering method	Control mode
ARST	After you troubleshoot the alarm, this DI is on and the error signal displayed by the servo drive is cleared.	Rising-edge triggered	All
Value: 0x03			
DI name	Description	Triggering method	Control mode
GAINUP	In Speed and Position modes, when this DI is on (P2.027 set to 0x0001), the gain value switches to the value which is the original gain multiplied by the rate of change.	Level triggered	PT, PR, S
Value: 0x04			
DI name	Description	Triggering method	Control mode
CCLR	Clear the pulse counter. Refer to P2.050 for the methods to clear the pulses. When this DI is on, the accumulative position pulse deviation of the drive (P0.002 = 33) is cleared to 0.	Rising-edge triggered, level triggered	PT, PR
Value: 0x05			
DI name	Description	Triggering method	Control mode
ZCLAMP	When the speed is slower than the setting of zero speed (P1.038), the motor stops operating when this DI is on. 	Level triggered	S
Value: 0x06			
DI name	Description	Triggering method	Control mode
CMDINV	In Speed and Torque modes, the input command is reversed when this DI is on.	Level triggered	S, Sz, T, Tz

8

Value: 0x08			
DI name	Description	Triggering method	Control mode
CTRG	In PR mode, after the PR command (POS0 - 6) is selected, the motor operates according to the command issued by the register when this DI is on.	Rising-edge triggered	PR

Value: 0x09			
DI name	Description	Triggering method	Control mode
TRQLM	In Speed and Position modes, motor torque is limited when this DI is on, and source of the Torque limit command is the internal register or analog voltage.	Level triggered	PT, PR, S

Value: 0x0A			
DI name	Description	Triggering method	Control mode
GTRY	When the gantry synchronization function is enabled (P1.074 = 2), switch this DI on to temporarily disable the monitoring function of the gantry synchronization. After receiving this DI, the servo stops calculating and monitoring the error between the two axes.	Rising-edge triggered	PT

Value: 0x0B			
DI name	Description	Triggering method	Control mode
FHS	Switch between full- and semi-closed loop modes.	Level triggered	PT, PR*

Note: PR full-closed loop function is not yet supported.

Value: 0x0C			
DI name	Description	Triggering method	Control mode
VPL	<p>Latch function of analog Position command. If this DI is on, the position of the motor is held at the current position when the DI is triggered. During this DI is on, the motor does not operate even when there is a change in the analog command. When this DI is off, the motor completes the command that was changed during the time DI was on.</p>	Level triggered	PT

Value: 0x0D			
DI name	Description	Triggering method	Control mode
VPRS	<p>Clear function of analog Position command. If this DI is on, the position of the motor is held at the current position when DI is triggered. Despite the change in the analog command during DI is on, the motor remains at the current position even when the DI is off. However, the position that the motor remains at corresponds to the new analog command. Thus, the analog input command redefines the position system of the motor.</p>	Level triggered	PT

Value: 0x0E			
DI name	Description	Triggering method	Control mode
FEC	When the servo drive is in full-closed loop mode and this DI is on, the error between the main encoder and the auxiliary encoder is cleared.	Rising-edge triggered	PT/PR full-closed loop

Value: 0x0F			
DI name	Description	Triggering method	Control mode
SPDKVC	Switch between P1.040 (Maximum motor speed for analog Speed command 1) and P1.081 (Maximum motor speed for analog Speed command 2).	Level triggered	S

Value: 0x10			
DI name	Description	Triggering method	Control mode
SPDLM	In Torque mode, motor speed is limited when this DI is on, and source of the Speed limit command is the internal register or analog voltage.	Level triggered	T

8

Value: 0x11, 0x12, 0x13, 0x1A, 0x1B, 0x1C, 0x1E												
DI name	Description										Triggering method	Control mode
POS0 POS1 POS2 POS3 POS4 POS5 POS6	PR command selection (1 - 99)										Level triggered	PR
	Position command	POS 6	POS 5	POS 4	POS 3	POS 2	POS 1	POS 0	CTRG	Corresponding parameter		
	Homing	0	0	0	0	0	0	0	↑	P6.000 P6.001		
	PR#1	0	0	0	0	0	0	1	↑	P6.002 P6.003		
	...									...		
	PR#50	0	1	1	0	0	1	0	↑	P6.098 P6.099		
	PR#51	0	1	1	0	0	1	1	↑	P7.000 P7.001		
	...									...		
	PR#99	1	1	0	0	0	1	1	↑	P7.098 P7.099		

Value: 0x1D				
DI name	Description		Triggering method	Control mode
ABSE	<p>When DI.ABSE is on, the servo is in absolute mode and can enable the functions of DI.ABSQ, DI.ABSC, DO.ABSR, and DO.ABSD at the same time.</p> <p>When DI.ABSE is on, the functions of DI4, DO2, and DO3 are no longer the ones assigned by the parameters. The DI4 function will be DI.ABSQ, DO2 will be DO.ABSR, and DO3 will be DO.ABSD. In addition, the DI point of DI.ABSC can be assigned by the parameter.</p>		Level triggered	All

Value: 0x1F				
DI name	Description		Triggering method	Control mode
ABSC	<p>When DI.ABSC is on, the current absolute position of the encoder is set as the origin definition (P6.001), but this DI is only valid when DI.ABSE is on.</p> <p>Note: in communication mode, the origin definition is the setting value of OD 607Ch multiplied by a negative sign.</p>		Rising-edge triggered	All

Value: when DI.ABSE is on, the DI.ABSQ from DI4 replaces the DI4 function from P2.013				
DI name	Description		Triggering method	Control mode
ABSQ always input by DI4	<p>During I/O transmission, the controller sends the handshaking signal. When DI.ABSQ is off, the controller issues the request; when DI.ABSQ is on, the controller has processed the ABSQ signal. This DI is only valid when DI.ABSE is on. Refer to Figure 10.3.4.1.1 for a detailed description.</p>		Rising- and falling-edge triggered	All

Value: 0x14, 0x15									
DI name	Description						Triggering method	Control mode	
SPD0 SPD1	Register Speed command selection (1 - 4)							Level triggered	S, Sz
	Speed command number	DI signal of CN1		Command source		Content	Range		
		SPD1	SPD0	S	External analog signal	Voltage difference between V_REF and GND	-10V to +10V		
	S1	0	0	Sz	N/A	Speed command is 0	0		
	S2	0	1	Internal register parameter		P1.009	+/- 75000 (rotary*) +/- 15999999 (linear*)		
	S3	1	0			P1.010	+/- 75000 (rotary) +/- 15999999 (linear)		
	S4	1	1			P1.011	+/- 75000 (rotary) +/- 15999999 (linear)		
Note: rotary means a permanent-magnet synchronous rotary motor; linear means a permanent-magnet synchronous linear motor.									

Value: 0x16, 0x17									
DI name	Description						Triggering method	Control mode	
TCM0 TCM1	Register Torque command selection (1 - 4)							Level triggered	T, Tz
	Torque command number	DI signal of CN1		Command source		Content	Range		
		TCM1	TCM0	T	External analog signal	Voltage difference between T_REF and GND	-10V to +10V		
	T1	0	0	Tz	N/A	Torque command is 0	0		
	T2	0	1	Internal register parameter		P1.012	+/- 5000%		
	T3	1	0			P1.013	+/- 5000%		
	T4	1	1			P1.014	+/- 5000%		

Value: 0x18					
DI name	Description			Triggering method	Control mode
S-P	In S-P dual / multi-mode, if this DI is off, it is in Speed mode; if this DI is on, it is in Position mode. Select PT or PR with DI.PT-PR (0x2B).			Level triggered	Dual / multi-mode

Value: 0x19					
DI name	Description			Triggering method	Control mode
S-T	In S-T dual / multi-mode, if this DI is off, it is in Speed mode; if this DI is on, it is in Torque mode.			Level triggered	Dual / multi-mode

Value: 0x20					
DI name	Description			Triggering method	Control mode
T-P	In T-P dual / multi-mode, if this DI is off, it is in Torque mode; if this DI is on, it is in Position mode. Select PT or PR with DI.PT-PR (0x2B).			Level triggered	Dual / multi-mode

Value: 0x21			
DI name	Description	Triggering method	Control mode
EMGS	When this DI is on, the motor stops immediately.	Level triggered	All

Value: 0x22			
DI name	Description	Triggering method	Control mode
NL (CWL)	Negative inhibit limit (normally closed contact).	Level triggered	All

Value: 0x23			
DI name	Description	Triggering method	Control mode
PL (CCWL)	Positive inhibit limit (normally closed contact).	Level triggered	All

Value: 0x24			
DI name	Description	Triggering method	Control mode
ORGP	During homing, when this DI is on, the servo regards this position as the homing origin. Refer to the setting of P5.004.	Rising- and falling-edge triggered	PR

Value: 0x27			
DI name	Description	Triggering method	Control mode
SHOM	During homing, when this DI is on, it activates the function to search for the origin. Refer to the setting of P5.004.	Rising-edge triggered	PR

Value: 0x2B			
DI name	Description	Triggering method	Control mode
PT-PR	Use this DI to select the command source in PT-PR dual mode or PT-PR-S multi-mode. If this DI is off, it is in PT mode; if this DI is on, it is in PR mode.	Level triggered	Dual / multi-mode

Value: 0x35			
DI name	Description	Triggering method	Control mode
ALGN	When the E-Cam phase alignment function is enabled (P2.076 [Bit 0] = 1 and P2.076 [Bit 1] = 1), the servo executes phase alignment when this DI is on.	Rising-edge triggered	PR

Value: 0x36			
DI name	Description	Triggering method	Control mode
CAM	E-Cam engaging control. Refer to the setting values of of P5.088.U and P5.088.Z.	Rising- and falling-edge triggered	PR

Value: 0x37			
DI name	Description	Triggering method	Control mode
JOGU	When this DI is on, the motor jogs in the positive direction.	Level triggered	All

Value: 0x38			
DI name	Description	Triggering method	Control mode
JOGD	When this DI is on, the motor jogs in the negative direction.	Level triggered	All

Value: 0x39			
DI name	Description	Triggering method	Control mode
EV1	Event trigger command 1. Refer to the setting of P5.098 and P5.099.	Rising- and falling-edge triggered	PR

Value: 0x3A			
DI name	Description	Triggering method	Control mode
EV2	Event trigger command 2. Refer to the setting of P5.098 and P5.099.	Rising- and falling-edge triggered	PR

Value: 0x3B			
DI name	Description	Triggering method	Control mode
EV3	Event trigger command 3. Refer to the setting of P5.098 and P5.099.	Rising- and falling-edge triggered	PR

Value: 0x3C			
DI name	Description	Triggering method	Control mode
EV4	Event trigger command 4. Refer to the setting of P5.098 and P5.099.	Rising- and falling-edge triggered	PR



8

Value: 0x43, 0x44			
DI name	Description	Triggering method	Control mode
GNUM0 GNUM1	<p>E-Gear ratio (numerator) selection 0 E-Gear ratio (numerator) selection 1 GNUM0, GNUM1</p>	Level triggered	PT

Value: 0x45			
DI name	Description	Triggering method	Control mode
INHP	In Position mode, the external pulse input command has no function when this DI is on. Note: this function has to be set to DI8 to ensure immediate pulse inhibition.	Level triggered	PT

Value: 0x46			
DI name	Description	Triggering method	Control mode
STP	Motor stops.	Rising-edge triggered	PR

Value: 0x47			
DI name	Description	Triggering method	Control mode
PFQS	Use this DI to set the emergency stop for deceleration time. The setting value for deceleration time is the same as that of P5.003. If this DI is on, AL35F occurs and the motor starts decelerating. When the speed reaches 0, AL3CF occurs and the servo is switched to Servo Off.	Rising-edge triggered	PT, PR, T, S

Note: the input function is disabled when P2.010 - P2.017 and P2.036 - P2.040 are set to 0.

**Table 8.2 Digital output (DO) descriptions**

Value: 0x01			
DO name	Description	Triggering method	Control mode
SRDY	When the control and main circuit power is applied to the drive, this DO is on if no alarm occurs.	Level triggered	All
Value: 0x02			
DO name	Description	Triggering method	Control mode
SON	<p>When the servo is activated (Servo On), this DO is on if no alarm occurs.</p> <p>The time difference between DO.SRDY and DO.SON when the servo is on as soon as power is applied</p> <p>Approx. 300 ns</p>	Level triggered	All
Value: 0x03			
DO name	Description	Triggering method	Control mode
ZSPD	When the motor speed is slower than the value of the zero speed (P1.038), this DO is on.	Level triggered	All
Value: 0x04			
DO name	Description	Triggering method	Control mode
TSPD	When the motor speed is faster than the target speed setting (P1.039), this DO is on.	Level triggered	All
Value: 0x05			
DO name	Description	Triggering method	Control mode
TPOS	When the deviation pulse number is smaller than the position range setting (setting value of P1.054), this DO is on.	Level triggered	PT, PR
Value: 0x06			
DO name	Description	Triggering method	Control mode
TQL	When the torque limit is activated, this DO is on.	Level triggered	All (except for T and Tz)

8

Value: 0x07			
DO name	Description	Triggering method	Control mode
ALRM	When a servo alarm occurs, this DO is on. (Except for positive / negative limit, communication error, and undervoltage.)	Level triggered	All

Value: 0x08			
DO name	Description	Triggering method	Control mode
BRKR	<p>Output signal of the magnetic brake control. Setting P1.042 and P1.043 to adjust the delay time before and after the magnetic brake control function is activated and deactivated.</p> <p>Refer to the note in P1.042.</p>	Level triggered	All

Value: 0x09			
DO name	Description	Triggering method	Control mode
HOME	When homing is complete, it means the position system and position counter are defined and this DO is on. When power is applied for the first time, this DO is off; when homing is complete, this DO is on. During operation, this DO is on until the position counter overflows (including commands or feedback). Then, this DO turns off. When the homing command is triggered, this DO is off; after homing is complete, this DO is on.	Level triggered	PR

Value: 0x0D			
DO name	Description	Triggering method	Control mode
ABSW	When an absolute encoder alarm occurs, this DO is on.	-	All

Value: 0x0E			
DO name	Description	Triggering method	Control mode
IDXD	When this DO is on, it means the rotary axis position is defined. When homing is complete, the rotary axis position is defined as well.	-	PR

Value: 0x10			
DO name	Description	Triggering method	Control mode
OLW	<p>This DO is on when the overload level setting is reached.</p> <p><math>t_{OL}</math> = Overload allowable time of the servo x Value for the overload warning level (P1.056).</p> <p>When the overload accumulative time exceeds <math>t_{OL}</math>, the servo sends the overload pre-warning (DO.OLW). However, if the overload accumulative time exceeds the overload allowable time of the servo, the servo sends the overload alarms (AL023 and AL006).</p> <p>For example: the value for the overload warning level is 60% (P1.056 = 60). When the output average load of the servo drive is 200% and the output time exceeds 8 seconds, the overload alarms (AL023 and AL006) occur.</p> <p><math>t_{OL}</math> = Duration when the output average load of the servo is 200% x Value for the overload warning level = 8 sec x 60% = 4.8 sec</p> <p>Result: when the output average load of the servo drive is 200% for over <math>t_{OL}</math> = 4.8 seconds, this overload warning DO (DO code: 0x10) is on. If the duration exceeds 8 seconds, the servo drive sends the early overload warning (AL023) and the overload error (AL006).</p>	Level triggered	All

Value: 0x11			
DO name	Description	Triggering method	Control mode
WARN	Warning outputs (positive / negative limit, communication error, and undervoltage).	Level triggered	All

Value: 0x12			
DO name	Description	Triggering method	Control mode
OVF	Position command / feedback overflows.	Level triggered	PT, PR

Value: 0x13			
DO name	Description	Triggering method	Control mode
SNL (SCWL)	Software limit (negative limit).	Level triggered	PR

Value: 0x14			
DO name	Description	Triggering method	Control mode
SPL (SCCWL)	Software limit (positive limit).	Level triggered	PR

Value: 0x15			
DO name	Description	Triggering method	Control mode
Cmd_OK	When the Position command is complete and the drive enters Position mode, this DO is on. When the Position command is executing, this DO is off; after the command completes, this DO is on. This DO only indicates that the command is complete, but the motor positioning may not be complete yet. Refer to DO.TPOS.	Level triggered	PR

Value: 0x16			
DO name	Description	Triggering method	Control mode
CAP_OK	Capture procedure is complete.	Level triggered	All

Value: 0x17			
DO name	Description	Triggering method	Control mode
MC_OK	When DO.Cmd_OK and DO.TPOS are both on, then this DO is on; otherwise it is off. Refer to P1.048.	Level triggered	PR

Value: 0x18			
DO name	Description	Triggering method	Control mode
CAM_AREA1	E-Cam area 1: the master axis phase is between the values of P5.090 and P5.091.	Level triggered	PR

Value: 0x19			
DO name	Description	Triggering method	Control mode
SP_OK	Motor speed reaches the target speed: in Speed mode, when the error between the speed feedback and the command is smaller than the value of P1.047, this DO is on.	Level triggered	S, Sz

Value: 0x1A			
DO name	Description	Triggering method	Control mode
CAM_AREA2	E-Cam area 2: the master axis phase is between the values of P2.078 and P2.079.	Level triggered	PR

Value: 0x2C			
DO name	Description	Triggering method	Control mode
Zon1	First set of general range comparison: when the value of the item monitored by P0.009 ranges between the values of P0.054 and P0.055, then this DO is on.	-	All

Value: 0x2D			
DO name	Description	Triggering method	Control mode
Zon2	Second set of general range comparison: when the value of the item monitored by P0.010 ranges between the values of P0.056 and P0.057, then this DO is on.	-	All

Value: 0x2E			
DO name	Description	Triggering method	Control mode
Zon3	Third set of general range comparison: when the value of the item monitored by P0.011 ranges between the values of P0.058 and P0.059, then this DO is on.	-	All

Value: 0x2F			
DO name	Description	Triggering method	Control mode
Zon4	Fourth set of general range comparison: when the value of the item monitored by P0.012 ranges between the values of P0.060 and P0.061, then this DO is on.	-	All

Value: 0x30			
DO name	Description	Triggering method	Control mode
SPO_0	Output bit 00 of P4.006.	Level triggered	All

Value: 0x31			
DO name	Description	Triggering method	Control mode
SPO_1	Output bit 01 of P4.006.	Level triggered	All

Value: 0x32			
DO name	Description	Triggering method	Control mode
SPO_2	Output bit 02 of P4.006.	Level triggered	All

Value: 0x33			
DO name	Description	Triggering method	Control mode
SPO_3	Output bit 03 of P4.006.	Level triggered	All

Value: 0x34			
DO name	Description	Triggering method	Control mode
SPO_4	Output bit 04 of P4.006.	Level triggered	All

Value: 0x35			
DO name	Description	Triggering method	Control mode
SPO_5	Output bit 05 of P4.006.	Level triggered	All

Value: 0x36			
DO name	Description	Triggering method	Control mode
SPO_6	Output bit 06 of P4.006.	Level triggered	All

Value: 0x37			
DO name	Description	Triggering method	Control mode
SPO_7	Output bit 07 of P4.006.	Level triggered	All

8

Value: 0x38			
DO name	Description	Triggering method	Control mode
SPO_8	Output bit 08 of P4.006.	Level triggered	All

Value: 0x39			
DO name	Description	Triggering method	Control mode
SPO_9	Output bit 09 of P4.006.	Level triggered	All

Value: 0x3A			
DO name	Description	Triggering method	Control mode
SPO_A	Output bit 10 of P4.006.	Level triggered	All

Value: 0x3B			
DO name	Description	Triggering method	Control mode
SPO_B	Output bit 11 of P4.006.	Level triggered	All

Value: 0x3C			
DO name	Description	Triggering method	Control mode
SPO_C	Output bit 12 of P4.006.	Level triggered	All

Value: 0x3D			
DO name	Description	Triggering method	Control mode
SPO_D	Output bit 13 of P4.006.	Level triggered	All

Value: 0x3E			
DO name	Description	Triggering method	Control mode
SPO_E	Output bit 14 of P4.006.	Level triggered	All

Value: 0x3F			
DO name	Description	Triggering method	Control mode
SPO_F	Output bit 15 of P4.006.	Level triggered	All

Note: the output function is disabled when P2.018 - P2.022 are set to 0.

<b>Value: 0x41</b>			
DO name	Description	Triggering method	Control mode
MAG_OK	Initial magnetic field detection is complete.	Level triggered	All

<b>Value: when DI.ABSE is on, DO.ABSR triggered by DO2 will replace the DO2 assigned by P2.019</b>			
DO name	Description	Triggering method	Control mode
ABSR always output by DO2	When DO.ABSR is off, it indicates servo drive can receive request issued by DI.ABSQ; when DO.ABSR is on, it indicates after the request is received, the data has been prepared and the ABSD data is valid so that the controller can access the ABSD data. This output is only valid when DI.ABSE is on. Refer to Figure 10.3.5.1.1 for a detailed description.	Level triggered	All

<b>Value: when DI.ABSE is on, DO.ABSD triggered by DO3 will replace the DO3 assigned by P2.020</b>			
DO name	Description	Triggering method	Control mode
ABSD always output by DO3	The DO for ABS data. This DO is only valid when DI.ABSE and DO.ABSR are both on. Refer to Figure 10.3.5.1.1 for a detailed description.	Level triggered	All



**Table 8.3 Monitoring variables descriptions**

Description of monitoring variables:

Item	Description
Monitoring code	Each monitoring variable has a code, and you can set the code to P0.002 and monitor the variable.
Format	Each monitoring variable is stored in the 32-bit format (long integer) in the servo drive.
Category	Basic variables / extension variables: 1. Basic variables: variables (P0.002 = 0 to 31) within the loop of pressing the UP / DOWN keys; in monitoring mode, use the UP / DOWN keys on the panel to display the variables. 2. Extension variables: variables other than basic variables.
Monitoring method	Panel display / mapping: 1. Panel display: monitor with the panel 2. Mapping: monitor variables or parameters by mapping parameters
Panel display	1. Use the MODE key to switch to the monitoring mode and press the UP / DOWN keys to select the variable to monitor. 2. Input the code of the variable to be monitored into P0.002 and start monitoring. Press the SHIFT key on the panel to switch between high and low digit display; press the SET key on the panel to switch between decimal and hexadecimal display.
Mapping	1. Parameters that support monitoring variable mapping: P0.009 - P0.013. Refer to Section 8.3 Parameter descriptions. 2. Read the monitoring variables through communication using mapping parameters. 3. The values of the mapping parameters (P0.009 - P0.013) are the content of the basic variables (17h, 18h, 19h, and 1Ah). To monitor P0.009, set P0.017 to the value to read (refer to P0.002). Read the data specified by P0.017 through communication or with the panel (set P0.002 to 23). When the panel displays "VAR-1", it then displays the content value of P0.009.

The property code of each monitoring variable is described in the following table:

Property	Description
<b>B</b>	BASE: basic variables. Select the variables with the UP / DOWN keys on the panel.
<b>D1 D2</b>	Decimal place displayed on the panel: <b>D1</b> indicates 1 decimal place and <b>D2</b> indicates 2 decimal places.
<b>Dec</b>	Only decimal display is available on the panel, and you cannot switch to hexadecimal display by pressing the SET key.
<b>Hex</b>	Only hexadecimal display is available on the panel, and you cannot switch to decimal display by pressing the SET key.

Monitoring variables are described in the following table by the code sequence:

Code	Variable name / property	Description
000 (00h)	Feedback position (PUU) <b>B</b>	Current feedback position of the motor encoder. Unit: Pulse of User Unit (PUU).
001 (01h)	Position command (PUU) <b>B</b>	Current position of the Position command. Unit: Pulse of User Unit (PUU). PT mode: number of pulse commands received by the servo drive. PR mode: absolute position of the Position command.
002 (02h)	Following error (PUU) <b>B</b>	Difference between the Position command before filtered and the feedback position. Unit: Pulse of User Unit (PUU).
003 (03h)	Feedback position (pulse) <b>B</b>	Current feedback position of the motor encoder. Unit: encoder unit (pulse).
004 (04h)	Position command (pulse) <b>B</b>	Current position of the Position command. Unit: encoder unit (pulse).
005 (05h)	Following error (pulse) <b>B</b>	Difference between the Position command before filtered and the feedback position. Unit: encoder unit (pulse).
006 (06h)	Pulse command frequency <b>B</b>	Frequency of the pulse command received by the drive. Unit: Kpps. Applicable to PT / PR modes.
007 (07h)	Speed feedback <b>B D1 Dec</b>	Current motor speed. Unit: 0.1 rpm. This is the speed after applying the low-pass filter, which makes it more stable.
008 (08h)	Speed command (analog) <b>B D2 Dec</b>	Speed command from the analog channel. Unit: 0.01 Volt.
009 (09h)	Speed command (integrated) <b>B</b>	Integrated Speed command. Unit: 0.1 rpm. Source includes analog, register, or position loop.
010 (0Ah)	Torque command (analog) <b>B D2 Dec</b>	Torque command from the analog channel. Unit: 0.01 Volt.
011 (0Bh)	Torque command (integrated) <b>B</b>	Integrated Torque command. Unit: percentage (%). Source includes analog, register, or speed loop.
012 (0Ch)	Average load rate <b>B</b>	Average load rate (moving average every 20 ms) from the servo drive. Unit: percentage (%).
013 (0Dh)	Peak load rate <b>B</b>	Maximum load rate from the drive. Unit: percentage (%).
014 (0Eh)	DC Bus voltage <b>B</b>	Rectified capacitor voltage. Unit: Volt.
015 (0Fh)	Load inertia ratio <b>B D1 Dec</b>	Ratio of the load inertia to the motor inertia. Unit: 0.1 times.
016 (10h)	IGBT temperature <b>B</b>	Temperature of IGBT. Unit: °C.
017 (11h)	Resonance frequency <b>B Dec</b>	Resonance frequency of the system, consisting of two sets of frequencies: F1 and F2 When monitoring from the panel, press the S key to switch between F1 and F2: F2 displays zero decimal places; F1 displays 1 decimal place. When reading by communication (mapping parameter): Low word returns frequency F2. High word returns frequency F1.

8

Code	Variable name / property	Description
018 (12h)	Z phase offset B Dec	Offset value between motor position and Z phase; range: -4999 to +5000. Where it overlaps with Z phase, the value is 0; the greater the value, the greater the offset.
019 (13h)	Mapping parameter content #1 B	Returns the value of P0.025 which is mapped by P0.035.
020 (14h)	Mapping parameter content #2 B	Returns the value of P0.026 which is mapped by P0.036.
021 (15h)	Mapping parameter content #3 B	Returns the value of P0.027 which is mapped by P0.037.
022 (16h)	Mapping parameter content #4 B	Returns the value of P0.028 which is mapped by P0.038.
023 (17h)	Mapping monitoring variable #1 B	Returns the value of P0.009 which is mapped by P0.017.
024 (18h)	Mapping monitoring variable #2 B	Returns the value of P0.010 which is mapped by P0.018.
025 (19h)	Mapping monitoring variable #3 B	Returns the value of P0.011 which is mapped by P0.019.
026 (1Ah)	Mapping monitoring variable #4 B	Returns the value of P0.012 which is mapped by P0.020.
027 (1Bh)	Z phase offset B	Offset value between motor position and Z phase. (Only available for Delta CNC controllers.)
028 (1Ch)	Alarm code Dec B	The alarm code (in decimal). The value being converted to the hexadecimal notation is identical to the alarm code displayed in P0.001 and the error code of communication models.
029 (1Dh)	Auxiliary encoder feedback (PUU) B	Position feedback from the auxiliary encoder.
030 (1Eh)	Auxiliary encoder position error (PUU) B	Position difference between the position feedback and the command from the auxiliary encoder.
031 (1Fh)	Position error between main and auxiliary encoders (PUU) B	Feedback position difference between the main encoder and auxiliary encoders.
032 (20h)	Position error (PUU)	Difference between the Position command after filtered and the feedback position. Unit: Pulse of User Unit (PUU).
033 (21h)	Position error (pulse)	Difference between the Position command after filtered and the feedback position. Unit: Pulse of User Unit (PUU).
035 (23h)	Rotary axis position command	Rotary axis position command at present. Unit: Pulse of User Unit (PUU).
037 (25h)	Compare data of Compare	The actual Compare data is the Compare data plus a specified value: $CMP\_DATA = DATA\_ARRAY[*] + P1.023 + P1.024$ .

Code	Variable name / property	Description
038 (26h)	Voltage level of the battery	Voltage level of the battery in an absolute encoder. To display the voltage level, enable the absolute encoder setting (P2.069).
039 (27h)	DI status (integrated) Hex	Integrated DI status of the drive. Each bit corresponds to one DI channel. Source includes hardware channel / P4.007, which is determined by P3.006.
040 (28h)	DO status (hardware) Hex	Actual status from the DO hardware. Each bit corresponds to one DO channel.
041 (29h)	Status of the drive	The value is returned to P0.046. Refer to the description of this parameter.
042 (2Ah)	PR number in execution	Displays the number of the PR command being executed.
043 (2Bh)	Captured data of CAP	The latest data captured by CAP. Note: CAP can continuously capture multiple points.
048 (30h)	Auxiliary encoder CNT	Pulse counts from the auxiliary encoder.
049 (31h)	Pulse command CNT	Pulse counts from the pulse command (CN1).
051 (33h)	Speed feedback (immediate) D1 Dec	Current actual motor speed. Unit: 0.1 rpm.
053 (35h)	Torque command (integrated) D1 Dec	Integrated Torque command. Unit: 0.1%. Source includes analog, register, or speed loop.
054 (36h)	Torque feedback D1 Dec	Current actual motor torque. Unit: 0.1%.
055 (37h)	Current feedback D2 Dec	Current actual motor current. Unit: 0.01 ampere (Amp).
056 (38h)	DC Bus voltage D1 Dec	Rectified capacitor voltage. Unit: 0.1 Volt.
059 (3Bh)	Accumulative pulse count of E-Cam master axis	Accumulative pulse count of the E-Cam master axis. Same as P5.086.
060 (3Ch)	Incremental pulse count of E-Cam master axis	Incremental pulse count of the E-Cam master axis. The increment per ms.
061 (3Dh)	Lead pulse number of E-Cam master axis	The lead pulse of the E-Cam master axis which determines the clutch engagement condition. When disengaged: lead pulse = P5.087 or P5.092; when the value is 0, the clutch engages. When engaged: lead pulse = P5.089; when the value is 0, the clutch disengages.
062 (3Eh)	Position of E-Cam master axis	Position of the E-Cam which corresponds to the master axis pulse and can be used to find the phase of the E-Cam. Unit: same as the master axis pulse; when the incremental pulse number of the master axis is P, E-Cam operates M cycles (P5.083 = M, P5.084 = P).
063 (3Fh)	Position of E-Cam slave axis	Position of the E-Cam slave axis and can be found from the E-Cam table. Unit: unit used in the E-Cam table.
064 (40h)	Register of PR command endpoint	In PR mode, the endpoint of the Position command (Cmd_E).
065 (41h)	Register of PR command output	In PR mode, the accumulative output of the Position command after filtered.
067 (43h)	PR target speed	Target speed specified in the PR path. Unit: PPS (pulse per second).

Code	Variable name / property	Description
072 (48h)	Speed command (analog) B D1 Dec	Speed command from the analog channel. Unit: 0.1 rpm.
081 (51h)	Synchronous Capture axis Incremental pulse input	When the synchronous Capture axis is enabled, the actual distance between two marks can be measured by the received pulse number between two captures.
082 (52h)	PR number in execution	Provides the number of the PR command currently executed by the servo drive to the HMC. (Available for F models)
084 (54h)	Synchronous Capture axis Pulse number of synchronous deviation	The accumulative deviation between the actual output pulse and the target pulse when the synchronous Capture axis is enabled. This value is close to 0 if synchronization is reached.
085 (55h)	E-Cam alignment deviation percentage	The alignment error rate after filtering. Unit: 0.1%. 10 indicates 1% and the angle conversion is $360^\circ \times 1\% = 3.6^\circ$ .
091 (5Bh)	Rotary axis position feedback	Immediate feedback of the rotary axis position. Unit: Pulse of User Unit (PUU).
096 (60h)	Drive firmware version Dec	Includes 2 versions: DSP and CPLD. When monitoring from the panel, press the S key to switch between DSP and CPLD: DSP displays zero decimal places; CPLD displays 1 decimal place. When reading by communication (mapping parameter): Low word returns the DSP version number; high word returns the CPLD version number.
111 (6Fh)	Error code of the servo drive	Error code from the servo drive: control loop of the servo only, not including the motion controller.
112 (70h)	CANopen SYNC TS (unfiltered)	The time the servo drive receives the SYNC signal (TimeStamp). Unit: $\mu\text{sec}$
113 (71h)	CANopen SYNC TS (filtered)	The time the servo drive receives the SYNC signal that has been processed by the low-pass filter. Unit: $\mu\text{sec}$
115 (73h)	Position error between main and auxiliary encoders (pulse)	Difference between the main encoder's current position and the auxiliary encoder's current position.
116 (74h)	Difference between current position and Z phase of auxiliary encoder (pulse)	Difference between the current position and the Z phase position of the auxiliary encoder.
119 (77h)	EtherCAT state machine	1: Init 2: Pre-Operational (Pre-OP) 4: Safe-Operational (Safe-OP) 8: Operational (OP)
120 (78h)	Communication error rate	When this value continues to increase, it indicates that there is communication interference. In an interference-free environment, this value should not increase. (Available on all models except A3-L)
123 (7Bh)	Value returned when monitoring by panel	Monitoring value displayed when returned to the panel.
-80	Encoder communication error rate	When this value continues to increase, it indicates that there is communication interference. In an interference-free environment, this value should not increase.
-91	Overload (AL006) protection counter	Displays the motor load during operation. When the value of the overload counter reaches 100%, AL006 occurs.

Code	Variable name / property	Description																						
-111	Regeneration error (AL005) protection counter	When the value of the regeneration counter reaches 100%, AL005 occurs.																						
-124	Encoder temperature	Monitor the encoder temperature.																						
-145	Delta linear motor NTC thermistor temperature	When PM.022 = 1, you can check the NTC thermistor temperature of Delta linear motor. (When PM.022 = 2 or 3, this function is not available.)																						
-169	Regenerative resistor overload (AL086) protection counter	The average power consumption (unit: %) of the regenerative resistor when the energy of the servo drive capacitor is released to the regenerative resistor. When the value of the regeneration counter reaches 100%, AL086 occurs.																						
-177	Main encoder's Hall sensor phase sequence and Z pulse data	Use the bit to determine the UVW phase sequence of the main encoder's Hall sensor and Z pulse. Bit 0: Z pulse, Bit 1: U phase, Bit 2: V phase, Bit 3: W phase. Note: use the ASDA-Soft scope function to monitor at the sampling rate of 16k / 20k. This monitoring variable is only available on third-party incremental encoders.																						
-178	Auxiliary encoder Z pulse data	Use the bit to check the Z pulse of the auxiliary encoder. Bit 0: Z pulse. Note: use the ASDA-Soft scope function to monitor at the sampling rate of 16k / 20k. This monitoring variable is only available on third-party incremental encoders.																						
-201	Number of pulse leakage	The accumulated number of pulse leakage monitored when the pulse leakage detection function is enabled (P2.081 = 1).																						
-202	Motor electrical angle	The current electrical angle multiplied by 4.																						
-206	Function status	When Bit 0 = 0, the function of auto tuning for linear motors is not supported. When Bit 0 = 1, the function of auto tuning for linear motors is supported, but the function must be used with ASDA-Soft V6.3.0.0 or later versions.																						
-207	Regenerative resistor power consumption	The power consumption (unit: %) of the regenerative resistor at the time when the energy of the servo drive capacitor is released to the regenerative resistor.																						
-213	Delta linear scale signal strength	<p>Detects the signal strength of Delta linear scale. (Unit: %)</p> <table border="1"> <thead> <tr> <th>LED on the read-head</th> <th>P0.002 = -213 (Signal strength (%))</th> <th>Definition</th> <th>LED on the read-head</th> <th>P0.002 = -213 (Signal strength (%))</th> <th>Definition</th> </tr> </thead> <tbody> <tr> <td>Green</td> <td>60 - 140</td> <td>Excellent</td> <td>Off</td> <td>-</td> <td>Readhead is above the Z position of the scale.</td> </tr> <tr> <td rowspan="2">Yellow</td> <td>40 - 60</td> <td>Below average</td> <td rowspan="2">Red</td> <td>&lt; 40</td> <td>Too weak</td> </tr> <tr> <td>140 - 160</td> <td>Above average</td> <td>&gt; 160</td> <td>Too strong</td> </tr> </tbody> </table> <p>Note: set P2.125 [Bit 11] to 1, then cycle power on the servo drive, and this monitoring variable is available. After the installation of the readhead is complete, if a load cell is used, you need to set P2.125 [Bit 11] to 0.</p>	LED on the read-head	P0.002 = -213 (Signal strength (%))	Definition	LED on the read-head	P0.002 = -213 (Signal strength (%))	Definition	Green	60 - 140	Excellent	Off	-	Readhead is above the Z position of the scale.	Yellow	40 - 60	Below average	Red	< 40	Too weak	140 - 160	Above average	> 160	Too strong
LED on the read-head	P0.002 = -213 (Signal strength (%))	Definition	LED on the read-head	P0.002 = -213 (Signal strength (%))	Definition																			
Green	60 - 140	Excellent	Off	-	Readhead is above the Z position of the scale.																			
Yellow	40 - 60	Below average	Red	< 40	Too weak																			
	140 - 160	Above average		> 160	Too strong																			

(This page is intentionally left blank.)

8

# Modbus Communication

# 9

This chapter describes the Modbus communication which you use for setting and accessing general parameters. For the motion control network, refer to the related DMCNET, CANopen, and EtherCAT documentation. The details of ASCII and RTU modes are also provided in this chapter.

---

9.1	RS-485 communication interface (hardware) .....	9-2
9.2	RS-485 communication parameter settings .....	9-3
9.3	Modbus communication protocol.....	9-4
9.4	Setting and accessing communication parameters.....	9-15
9.5	RS-485 communication specification .....	9-16



9

### 9.1 RS-485 communication interface (hardware)

The ASDA-A3 series servo drive supports RS-485 serial communication that you can use to access and change the parameters of the servo system. See the following description of the wiring:

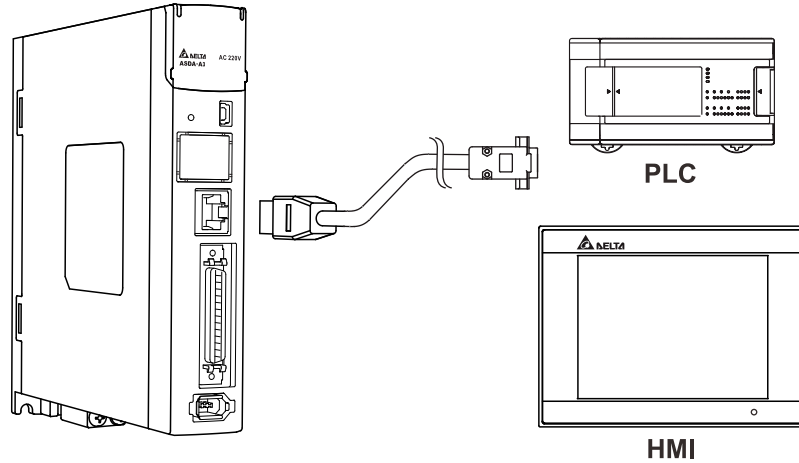

CN3 RJ45

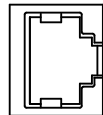

D-Sub 9-pin

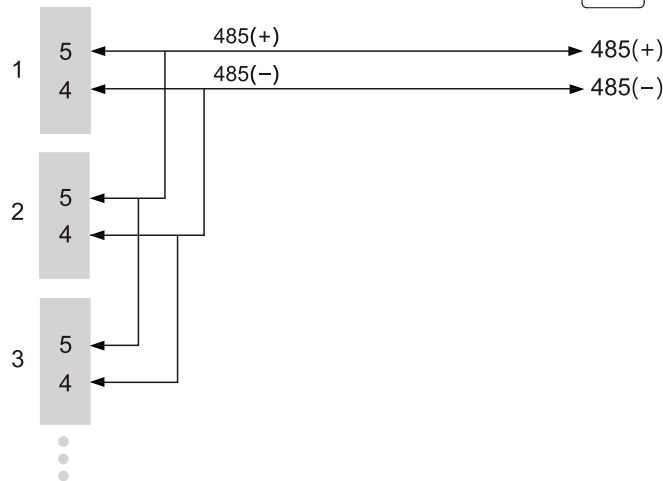
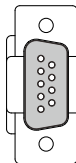

Note:

1. The cable length can be up to 100 meters when the servo drive is installed in a quiet environment. If the transmission speed is over 38,400 bps, a 15-meter cable is recommended to ensure data transmission accuracy.
2. The numbers (4 and 5) on the preceding figure represent the pin number of each connector.
3. Use 12 V<sub>DC</sub> for the power supply.
4. When using RS-485 communication, you may connect up to 32 servo drives. Install a repeater to connect more servo drives (the maximum is 127 stations).
5. Refer to Wiring for the CN3 connector in Chapter 3.

## 9.2 RS-485 communication parameter settings

The required parameters for a single servo drive connection are: P3.000 (Address), P3.001 (Transmission speed), and P3.002 (Modbus communication protocol). P3.003 (Modbus communication error handling), P3.004 (Modbus communication timeout), P3.006 (Digital input (DI) control switch), and P3.007 (Modbus communication response delay time) are optional settings.

Refer to Chapter 8 for detailed descriptions of the relevant parameters.

Parameter	Function
P3.000	Address
P3.001	Transmission speed
P3.002	Modbus communication protocol

## 9

### 9.3 Modbus communication protocol

There are two modes of Modbus network communication: ASCII (American Standard Code for Information Interchange) and RTU (Remote Terminal Unit). You can set the communication protocol (ASCII or RTU) with P3.002 according to your requirements. The ASDA-A3 servo drive also supports these functions: accessing multiple words (03H), writing single word (06H), and writing multiple words (10H). Refer to the following descriptions.

#### Code description

##### ASCII mode:

In ASCII mode, data is transmitted in ASCII (American Standard Code for Information Interchange) format. For instance, to transmit “64H” between the master and slave, the ASCII codes “36H” and “34H” are sent to represent “6” and “4” respectively.

Note: the servo drive does not support the broadcast mode.

The corresponding ASCII codes for the numbers 0 to 9 and the characters A to F are as follows:

Symbol	'0'	'1'	'2'	'3'	'4'	'5'	'6'	'7'
ASCII code	30H	31H	32H	33H	34H	35H	36H	37H
Symbol	'8'	'9'	'A'	'B'	'C'	'D'	'E'	'F'
ASCII code	38H	39H	41H	42H	43H	44H	45H	46H

##### RTU mode:

Each data frame consists of an 8-bit character (hexadecimal), which is more efficient than ASCII mode for data transmission because it can be done without code interchange. For instance, when transmitting “64H” between the master and slave, simply send “64H”.

Characters are encoded into the following frames and transmitted in series. The methods for checking each type of frame are as follows.

ASCII mode:

10-bit character frame (for 7-bit character)

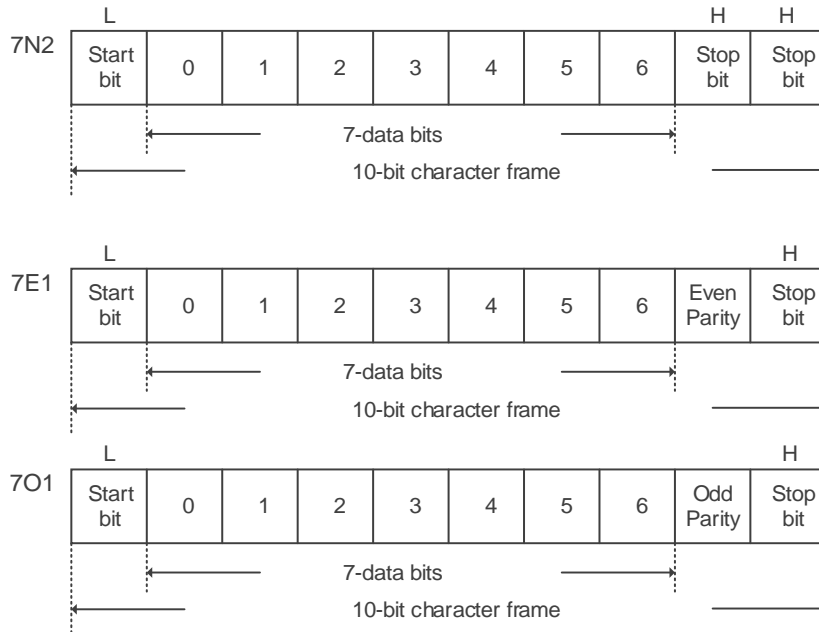

RTU mode:

11-bit character frame (for 8-bit character)

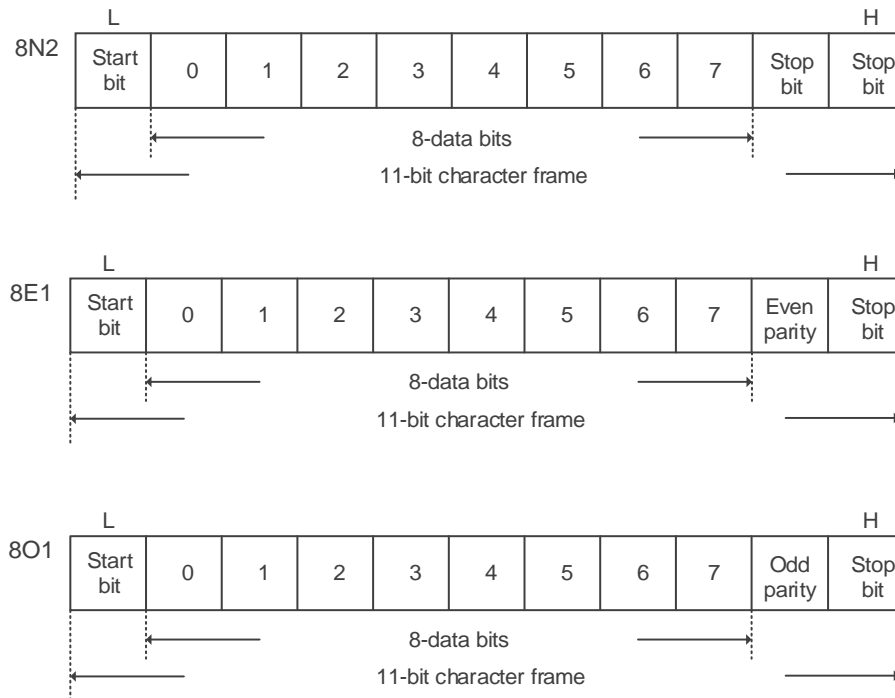

9

**Communication data structure**

Definitions for the data frames in the two modes are as follows:

ASCII mode:

Start	Start character ":" (3AH)
Slave Address	Communication address: 1 byte consists of 2 ASCII codes (ADR)
Function	Function code: 1 byte consists of 2 ASCII codes (CMD)
Data (n-1)	Data content: n-word = 2n-byte consists of 4n ASCII codes, n ≤ 10
.....	
Data (0)	
LRC	Error checking: 1 byte consists of 2 ASCII codes
End 1	End code 1: (0DH) (CR)
End 0	End code 0: (0AH) (LF)

In ASCII communication mode, the message starts with a colon ":" (ASCII code: 3AH). The ADR consists of 2 ASCII codes. The message ends with CR (Carriage Return) and LF (Line Feed). The codes for data such as communication address, function code, data content, and LRC (Longitudinal Redundancy Check) are between the start character and the end code.

RTU mode:

Start	A silent interval of more than 10 ms
Slave Address	Communication address: 1 byte
Function	Function code: 1 byte
Data (n-1)	Data content: n-word = 2n-byte, n ≤ 10
.....	
Data (0)	
CRC	Error checking: 2 bytes
End 1	A silent interval of more than 10 ms

In RTU communication mode, the message starts and ends with silent intervals. The codes for data such as communication address, function code, data content, and CRC (Cyclical Redundancy Check) are between the start and end intervals.

Example 1: function code 03H, accessing multiple words.

In the following example, the master issues a read command to the first slave.

The slave accesses two continuous words starting from the start data address 0200H. In the response message from the slave, the content of the start data address 0200H is 00B1H, and the content of the second data address 0201H is 1F40H. The maximum allowable data in one single access is 10 words.

ASCII mode:

Command Message (Master):

Start	‘:’
Slave Address	‘0’
	‘1’
Function	‘0’
	‘3’
Start Data Address	‘0’
	‘2’
	‘0’
	‘0’
Data Quantity (in words)	‘0’
	‘0’
	‘0’
	‘2’
LRC	‘F’
	‘8’
End 1	(0DH) (CR)
End 0	(0AH) (LF)

Response Message (Slave):

Start	‘:’
Slave Address	‘0’
	‘1’
Function	‘0’
	‘3’
Data Quantity (in bytes)	‘0’
	‘4’
Content of Start Data Address 0200H	‘0’
	‘0’
	‘B’
Content of the 2 <sup>nd</sup> Data Address 0201H	‘1’
	‘F’
	‘4’
	‘0’
LRC	‘E’
	‘8’
End 1	(0DH) (CR)
End 0	(0AH) (LF)

RTU mode:

Command Message (Master):

Slave Address	01H
Function	03H
Start Data Address	02H (High)
	00H (Low)
Data Quantity (in words)	00H
	02H
CRC (Check Low)	C5H (Low)
CRC (Check High)	B3H (High)

Response Message (Slave):

Slave Address	01H
Function	03H
Data Quantity (in bytes)	04H
Content of Start Data Address 0200H	00H (High)
	B1H (Low)
Content of the 2 <sup>nd</sup> Data Address 0201H	1FH (High)
	40H (Low)
CRC (Check Low)	A3H (Low)
CRC (Check High)	D4H (High)

Note: a silent interval of 10 ms is required before and after each transmission in RTU mode.

9

Example 2: function code 06H, writing single word.

In the following example, the master issues a write command to the first slave.

The slave writes data 0064H to address 0200H. The slave sends a response message to the master after the writing is complete.

ASCII mode:

Command Message (Master):

Start	‘:’
Slave Address	‘0’
	‘1’
Function	‘0’
	‘6’
Start Data Address	‘0’
	‘2’
	‘0’
	‘0’
Data Content	‘0’
	‘0’
	‘6’
	‘4’
LRC	‘9’
	‘3’
End 1	(0DH) (CR)
End 0	(0AH) (LF)

Response Message (Slave):

Start	‘:’
Slave Address	‘0’
	‘1’
Function	‘0’
	‘6’
Start Data Address	‘0’
	‘2’
	‘0’
	‘0’
Data Content	‘0’
	‘0’
	‘6’
	‘4’
LRC	‘9’
	‘3’
End 1	(0DH) (CR)
End 0	(0AH) (LF)

RTU mode:

Command Message (Master):

Slave Address	01H
Function	06H
Start Data Address	02H (High)
	00H (Low)
Data Content	00H (High)
	64H (Low)
CRC (Check Low)	89H (Low)
CRC (Check High)	99H (High)

Response Message (Slave):

Slave Address	01H
Function	06H
Start Data Address	02H (High)
	00H (Low)
Data Content	00H (High)
	64H (Low)
CRC (Check Low)	89H (Low)
CRC (Check High)	99H (High)

Note: a silent interval of 10 ms is required before and after each transmission in RTU mode.

Example 3: function code 10H, writing multiple words.

In the following example, the master issues a write command to the first slave.

The slave writes data 0BB8H and 0000H starting from the start data address 0112H. In other words, 0BB8H is written into 0112H and 0000H is written into 0113H. The maximum allowable data in one single access is 8 words. The slave sends a response message to the master after the writing is complete.

ASCII mode:

Command Message (Master):

Start	':'
Slave Address	'0'
	'1'
Function	'1'
	'0'
Start Data Address	'0'
	'1'
	'1'
	'2'
Data Quantity (in words)	'0'
	'0'
	'0'
	'2'
Data Quantity (in bytes)	'0'
	'4'
Content of the 1 <sup>st</sup> Data Frame	'0'
	'B'
	'B'
	'8'
Content of the 2 <sup>nd</sup> Data Frame	'0'
	'0'
	'0'
	'0'
LRC	'1'
	'3'
End 1	(0DH) (CR)
End 0	(0AH) (LF)

Response Message (Slave):

Start	':'
Slave Address	'0'
	'1'
Function	'1'
	'0'
Start Data Address	'0'
	'1'
	'1'
	'2'
Data Quantity (in words)	'0'
	'0'
	'0'
	'2'
LRC	'D'
	'A'
End 1	(0DH) (CR)
End 0	(0AH) (LF)



9

RTU mode:

Command Message (Master):

Slave Address	01H
Function	10H
Start Data Address	01H (High)
	12H (Low)
Data Quantity (in words)	00H (High)
	02H (Low)
Data Quantity (in bytes)	04H
Content of the 1 <sup>st</sup> Data Frame	0BH (High)
	B8H (Low)
Content of the 2 <sup>nd</sup> Data Frame	00H (High)
	00H (Low)
CRC (Check Low)	FCH (Low)
CRC (Check High)	EBH (High)

Response Message (Slave):

Slave Address	01H
Function	10H
Start Data Address	01H (High)
	12H (Low)
Data Quantity (in words)	00H (High)
	02H (Low)
CRC (Check Low)	E0H (Low)
CRC (Check High)	31H (High)

Note: a silent interval of 10 ms is required before and after each transmission in RTU mode.

### LRC and CRC transmission error checking

In ASCII mode, the error checking method is LRC (Longitudinal Redundancy Check). In RTU mode, the error checking method is CRC (Cyclical Redundancy Check). See the following details.

LRC (ASCII mode):

Start	':'
Slave Address	'7'
	'F'
Function	'0'
	'3'
Start Data Address	'0'
	'5'
	'C'
	'4'
Data Quantity (in words)	'0'
	'0'
	'0'
	'1'
LRC	'B'
	'4'
End 1	(0DH) (CR)
End 0	(0AH) (LF)

To calculate the LRC value: add all the bytes, round down the carry, and take the two's complement. For example:  $7FH + 03H + 05H + C4H + 00H + 01H = 14CH$ , round down the carry 1 and take 4CH. The two's complement of 4CH is B4H.

9

CRC (RTU mode):

To calculate the CRC value:

Step 1: load a 16-bit register with the content of FFFFH, which is called the "CRC" register.

Step 2: (The low byte of the CRC register) XOR (The first byte of the command), and save the result in the CRC register.

Step 3: check the least significant bit (LSB) of the CRC register. If the bit is 0, shift the register one bit to the right. If the bit is 1, shift the register one bit to the right and perform (CRC register) XOR (A001H). Repeat this step 8 times.

Step 4: repeat steps 2 and 3 until all bytes have been processed. The content of the CRC register is the CRC value.

After calculating the CRC value, fill in the low byte of the CRC value in the command message, and then the high byte. For example, if the result of CRC calculation is 3794H, put 94H in the message and then 37H as shown in the following table.

ADR	01H
CMD	03H
Start Data Address	01H (High)
	01H (Low)
Data Quantity (in words)	00H (High)
	02H (Low)
CRC (Check Low)	94H (Low)
CRC (Check High)	37H (High)

**CRC program example:**

This function calculates the CRC value in the C language. It needs two parameters:

```

unsigned char* data;
unsigned char length
//The function returns the CRC value as a type of unsigned integer.
unsigned int crc_chk(unsigned char* data, unsigned char length) {
    int j;
    unsigned int reg_crc=0xFFFF;

    while( length-- ) {
        reg_crc^= *data++;
        for (j=0; j<8; j++ ) {
            if( reg_crc & 0x01 ) { /*LSB(bit 0 ) = 1 */
                reg_crc = (reg_crc >> 1)^0xA001;
            } else {
                reg_crc = (reg_crc>>1);
            }
        }
    }
    return reg_crc;
}

```

Example of a PC communication program:

```

#include<stdio.h>
#include<dos.h>
#include<conio.h>
#include<process.h>
#define PORT 0x03F8 /* the address of COM 1 */
#define THR 0x0000
#define RDR 0x0000
#define BRDL 0x0000
#define IER 0x0001
#define BRDH 0x0001
#define LCR 0x0003
#define MCR 0x0004
#define LSR 0x0005
#define MSR 0x0006
unsigned char rdat[60];
/* read 2 data from address 0200H of ASD with address 1 */
unsigned char
tdat[60]={':', '0', '1', '0', '3', '0', '2', '0', '0', '0', '0', '0', '2', 'F', '8', '\r', '\n'};
void main() {
    int I;
    outportb(PORT+MCR,0x08); /* interrupt enable */
    outportb(PORT+IER,0x01); /* interrupt as data in */
    outportb(PORT+LCR,( inportb(PORT+LCR) | 0x80 ) );
    /* the BRDL/BRDH can be access as LCR.b7 == 1 */
    outportb(PORT+BRDL,12);
}

```

## 9

```
outportb(PORT+BRDH,0x00);
outportb(PORT+LCR,0x06);      /* set protocol
                               <7,E,1> = 1AH,      <7,0,1> = 0AH
                               <8,N,2> = 07H      <8,E,1> = 1BH
                               <8,0,1> = 0BH      */

for( I = 0; I<=16; I++ ) {
    while( !(inportb(PORT+LSR) & 0x20) ); /* wait until THR empty */
    outportb(PORT+THR,tdat[I]);          /* send data to THR */
}
I = 0;
while( !kbhit() ) {
    if( inportb(PORT+LSR)&0x01 ) { /* b0==1, read data ready */
        rdat[I++] = inportb(PORT+RDR); /* read data from RDR */
    }
}
}
```

## 9.4 Setting and accessing communication parameters

Refer to Chapter 8 for the descriptions of the parameters that you can set or access through communication.

The ASDA-A3 servo drive parameters are divided into nine groups: Group 0 (Monitoring parameters), Group 1 (Basic parameters), Group 2 (Extension parameters), Group 3 (Communication parameters), Group 4 (Diagnosis parameters), Group 5 (Motion control parameters), Group 6 and Group 7 (PR parameters), and Group M (Motor parameters).

### Setting parameters through communication:

You can set these parameters through communication:

Group 0, except P0.000 - P0.001, P0.008 - P0.013, and P0.046.

Group 1

Group 2

Group 3

Group 4, except P4.000 - P4.004 and P4.008 - P4.009.

Group 5, except P5.010, P5.016, and P5.076.

Group 6

Group 7

Group M

### Note the following additional details:

P3.001: when a new communication speed is set, the next data is written in the new transmission speed.

P3.002: when a new communication protocol is set, the next data is written with the new communication protocol.

P4.005: JOG control parameter. Refer to Chapter 8 for detailed descriptions.

P4.006: force digital output (DO) contact control. Use this parameter to test the DO contact. Set P4.006 to 1, 2, 4, 8, 16, and 32 to test DO1, DO2, DO3, DO4, DO5, and DO6, respectively. Then, set P4.006 to 0 to complete the test.

P4.010: calibration functions. First set P2.008 to 20 (14H in hexadecimal format) to enable this function.

P4.011 - P4.021: these parameters are for adjusting the hardware offset. The parameters were adjusted before delivery, so changing these parameters is not recommended. If you need to modify these parameters, first set P2.008 to 22 (16H in hexadecimal format).

### Accessing parameters through communication:

You can read the values from these parameters through communication: Group 0 - Group 7 and Group M.

## 9

## 9.5 RS-485 communication specification

Compared with RS-232, the RS-485 communication can carry out one-to-many transmission and has better anti-interference ability. RS-485 mainly uses a balanced transmission line for signal reception and transmission. The transmitter converts the TTL signal into a differential signal and then sends it to the receiver. The receiver receives the differential signal and then converts it back to the TTL signal. Since the transmission process uses the differential signal, it has better anti-interference ability. However, there are still restrictions on its use, so note the following when wiring.

- **Number of stations**

CN3 can only support up to 32 servo drive stations. If your application requires more than 32 stations, install a repeater to connect more servo drives. The current maximum is 127 stations.
- **Transmission distance**

The longer the transmission distance, the slower the transmission rate. The cable length can be up to 100 meters when the servo drive is installed in a quiet environment. If the required transmission speed is over 38,400 bps, a 15-meter cable is recommended to ensure data transmission accuracy.
- **Transmission line**

The quality of the transmission line affects the signal transmission process. If there is interference during the transmission process, it may result in data loss. It is suggested that you use a shielded twisted-pair cable as the outer layer has a shield layer of metal and grounding wire, which has better anti-interference ability.
- **Topology**

For topology, the closer to the master station, the more stable the transmitted signal. RS-485 supports bus topology. The transmission line must connect from the first station to the second station, and then from the second station to the third station, and so on until the last station. RS-485 does not support star and ring topologies.
- **Terminal resistor**

In the communication transmission process, if the impedance is not continuous, it causes signal reflection and signal distortion. This usually happens to the device that is configured at the end of the transmission line. If the impedance of the transmission line is small or 0  $\Omega$ , the signal will be reflected. To solve this problem, add a resistor of the same characteristic impedance at the end of the transmission line, which is called a terminal resistor. In general, the transmission line used in the RS-485 signal transmission circuit is a twisted-pair cable, and its characteristic impedance is about 120  $\Omega$ , so the impedance of the terminal resistor is also 120  $\Omega$ .

■ Anti-interference methods

In the signal transmission process, if there is interference, it may result in signal distortion. Therefore, it is important to eliminate interference. The elimination methods are as follows:

1. Add a terminal resistor.
2. Check if the servo drive is installed in a high magnetic field environment. If so, keep it as far away as possible.
3. Use a shielded twisted-pair cable for the transmission line.
4. When wiring, isolate the high voltage power cable from the signal line.
5. Use a magnetic ring at the power input. For its usage, refer to Section 2.6.
6. Add X capacitor and Y capacitor, which are IEC 60384-14 certified, at the power input.



(This page is intentionally left blank.)

9

# Absolute System

# 10

This chapter introduces the absolute servo system, including the wiring and installation of the absolute encoder, the steps to set up the system, and the procedures for initializing and operating the system for the first time.

---

10.1	Battery box and absolute encoder cable .....	10-3
10.1.1	Battery specifications .....	10-3
10.1.2	Battery box dimensions .....	10-5
10.1.3	Connection cable for the absolute encoder .....	10-6
10.1.4	Battery box cable .....	10-7
10.2	Installation .....	10-8
10.2.1	Installing the battery box in the servo system .....	10-8
10.2.2	Installing and replacing batteries .....	10-11
10.3	System initialization and operating procedures .....	10-14
10.3.1	System initialization .....	10-14
10.3.2	Pulse number .....	10-15
10.3.3	PUU number .....	10-16
10.3.4	Establishing the absolute origin position .....	10-17
10.3.4.1	Establishing the absolute origin position with DI/DO .....	10-17
10.3.4.2	Establishing the absolute origin position with parameters .....	10-18
10.3.4.3	Establishing the absolute origin position with the PR homing function .....	10-18
10.3.5	Reading the absolute position .....	10-18
10.3.5.1	Reading the absolute position with DI/DO .....	10-18
10.3.5.2	Reading the absolute position with communication .....	10-21
10.4	Parameters, DI/DO, and alarms related to absolute function .....	10-23

# 10

**Important**

A complete absolute servo system includes an ASDA-A3 servo drive, an absolute motor, and a backup battery box. The backup battery supplies power to the system so that the encoder continues operating when the main power to the servo drive is off. In addition, the absolute encoder can continuously record the motor's actual position at any time, even when the motor shaft is rotated after the power is off. The absolute servo system must be used only with an absolute motor. If the servo drive is set up with an incremental motor and the absolute function is enabled (P2.069.X =1), AL069 occurs.

**When using an absolute motor, make sure the motor speed is lower than 250 rpm at the moment when power is on. When the encoder is operating with the battery, make sure the maximum speed of the motor does not exceed 200 rpm.**

To determine whether you use an absolute motor, check the model number as shown in the following:

**ECM-A3 series servo motor**

ECM - A3 □ - □ Y □ □ □ □ □ □ □ □  
 └ Y: absolute motor

**ECM-B3 series servo motor**

ECM - B3 □ - □ □ □ □ □ □ □ □ □ □  
 └ A / P: absolute motor

**ECMC series servo motor**

ECMC - □ W □ □ □ □ □ □ □ □  
 └ W: absolute motor

Install the battery correctly on the encoder. One servo drive uses one single battery box; two servo drives can share one dual battery box. Use Delta's encoder cable to connect to the battery box. See the following sections for the specifications of the battery box and its accessories.

## 10.1 Battery box and absolute encoder cable

### 10.1.1 Battery specifications

#### Precautions

Carefully read the following safety precautions. Use batteries only in accordance with the specifications to avoid damage or dangerous conditions.



- Make sure the installation location is free of vapor and corrosive and inflammable gas.
- Correctly place the battery into the battery box to avoid short-circuiting.
- Do not short-circuit the positive and negative electrodes of the battery, and do not install the batteries in reverse direction.
- Do not mix new and used batteries to avoid losing power or shortening the life of the new batteries. Replacing all batteries with new ones is recommended.
- Follow the instructions when installing and wiring the battery box to avoid dangerous conditions.



- Do not place the battery in a high-temperature environment over 100°C (212°F), as this may cause a fire or an explosion.
- The batteries are non-rechargeable. Do not charge the batteries as this may result in an explosion.
- Do not directly weld on the surface of the battery.

#### Battery specifications

Item	Li/SOCI2 Cylindrical Battery
Model number	ER14505
Delta model number	ASD-CLBT0100
International standard size	AA
Normal voltage	3.6V
Normal capacity	2700 mAh
Maximum continuous discharge current	100 mA
Maximum pulse current	200 mA
Dimensions (D x H)	14.5 x 50.5 mm
Weight	Approx. 19 g
Operating temperature	-40°C to +85°C (-40°F to +185°F)
Supplier	EVE Energy Co., Ltd
Part number for the battery with wires	0991023281

# 10

## Battery life

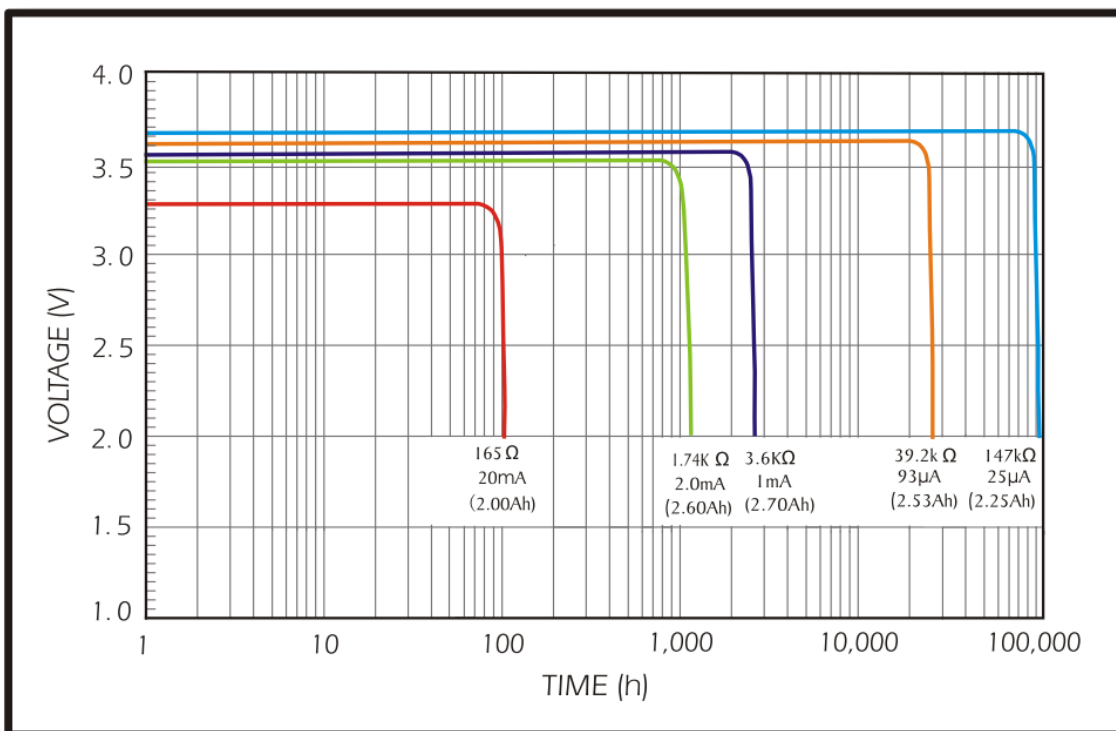

Source: EVE Energy Co. ER14505 Discharge Characteristics

(1) The preceding figure illustrates the discharge current curves measured in the constant current test. According to the five curves shown in the preceding figure, if the voltage of the battery keeps at 3V or higher, the expected battery life is as shown in the following table. Therefore, the lowest battery voltage level for an absolute encoder is set to 3.1V.

Motor	Current consumption <sup>2</sup> (μA) when the encoder operates with the battery	Battery life expectancy (month)
ECM-A3□-□A□□□□□□□□ ECM-B3□-□A□□□□□□□□ ECM-B3□-□P□□□□□□□□	30	87.5
ECMC-□W□□□□□□□□ ECM-A3□-□Y□□□□□□□□	45	58.33
ECMC-□V□□□□□□□□	35	75

(2) The battery voltage can keep at 3.6V or above up to 5 years when the battery is stored in a cool dry place.

Note:

1. The battery life expectancy is measured with a test using a servo drive, a motor, and a single battery.
2. The current consumption is nearly 0 when the absolute origin position is not established. Once the absolute origin position is established, the battery power consumption starts. To avoid battery power consumption when the machine is in transport, it is recommended that you disconnect the battery from the servo drive or do not establish the absolute origin position.

### 10.1.2 Battery box dimensions

Single battery box part number: ASD-MDBT0100

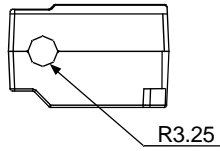
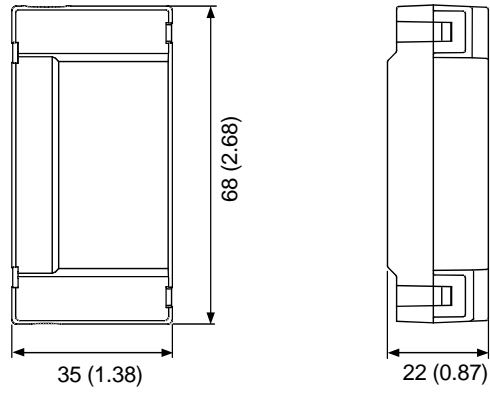

Unit : mm (inch)  
Weight: 44 g

Dual battery box part number: ASD-MDBT0200

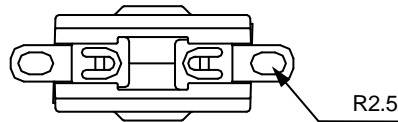
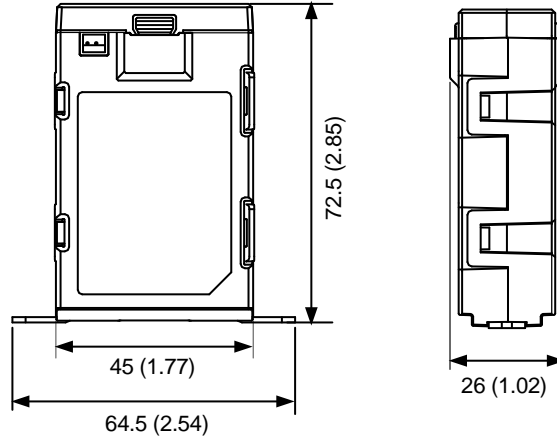

Unit : mm (inch)  
Weight: 79.23 g

### 10.1.3 Connection cable for the absolute encoder

Connector type	Applicable model		Wiring description
Standard	ECM-A3 / ECM-B3	F40 - F80 models	Refer to Section 3.1.5.1 in Chapter 3.
CHOGORI	ECM-A3 / ECM-B3 220V series	F40 - F80 models	
Bulkhead	ECM-B3 220V series	F40 - F80 models	
ECMC military	ECMC series	F100 - F180 models	Refer to Section 3.1.5.2 in Chapter 3.
B3 military	ECM-B3 series	F100 - F220 models	Refer to Section 3.1.5.3 in Chapter 3.

10

### 10.1.4 Battery box cable

#### Battery box cable for customized wiring

Delta part number: 3864850600

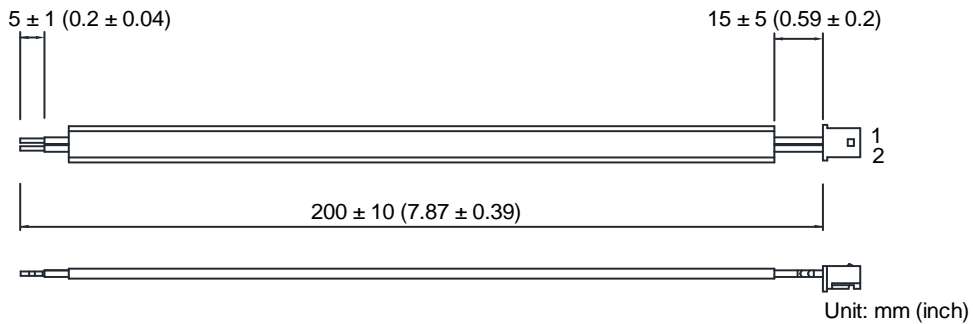

#### Battery box cable that connects to the encoder cable (both ends are male)

Delta part number: 3864811901

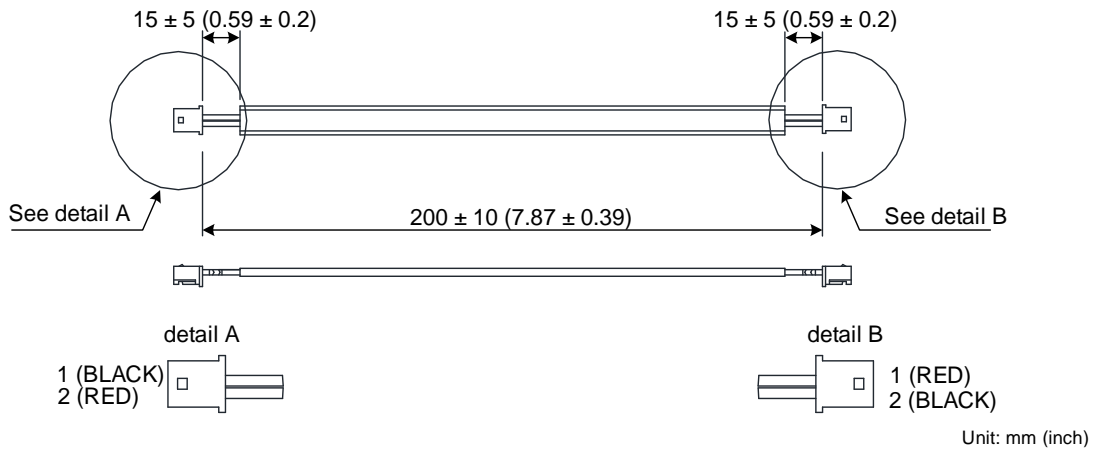

#### Battery box cable that connects to the encoder cable (one male end and one female end)

Delta part number: 3864573700

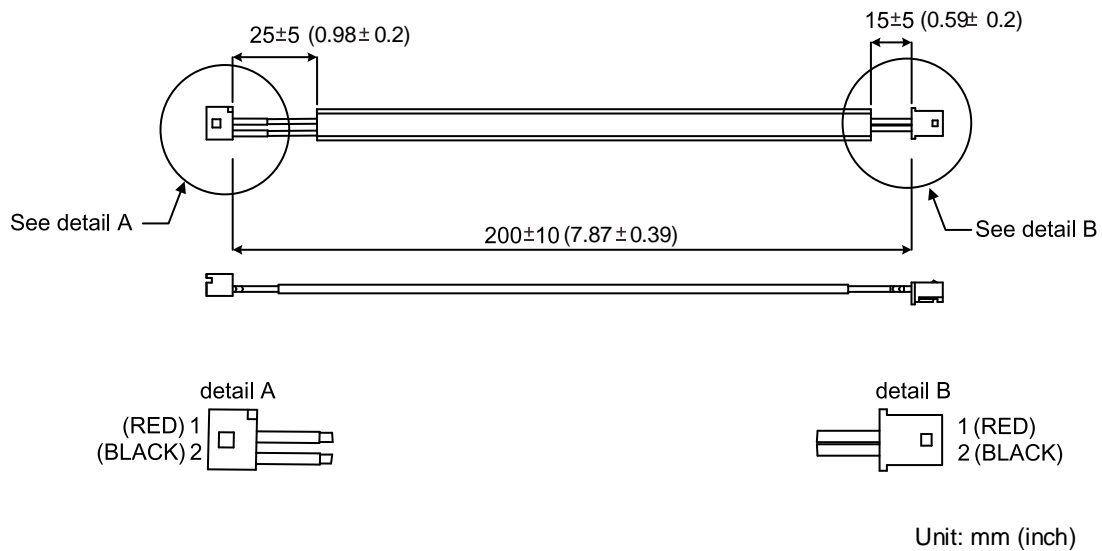



# 10

## 10.2 Installation

### 10.2.1 Installing the battery box in the servo system



- DO NOT connect to Pin 3 and Pin 4 of the servo drive CN2 connector. These pins are for third-party motors and internal use only\*. Wiring them will cause damage to the internal circuit.
- When an absolute encoder is used, the battery supplies power directly to the encoder, so wiring the battery wires to the CN2 connector of the servo drive is not required.

Note: if you are using a third-party motor supported by ASDA-A3, refer to Chapter 11 Linear Motor and Third-Party Motor for wiring.

#### Single battery box (standard wiring)

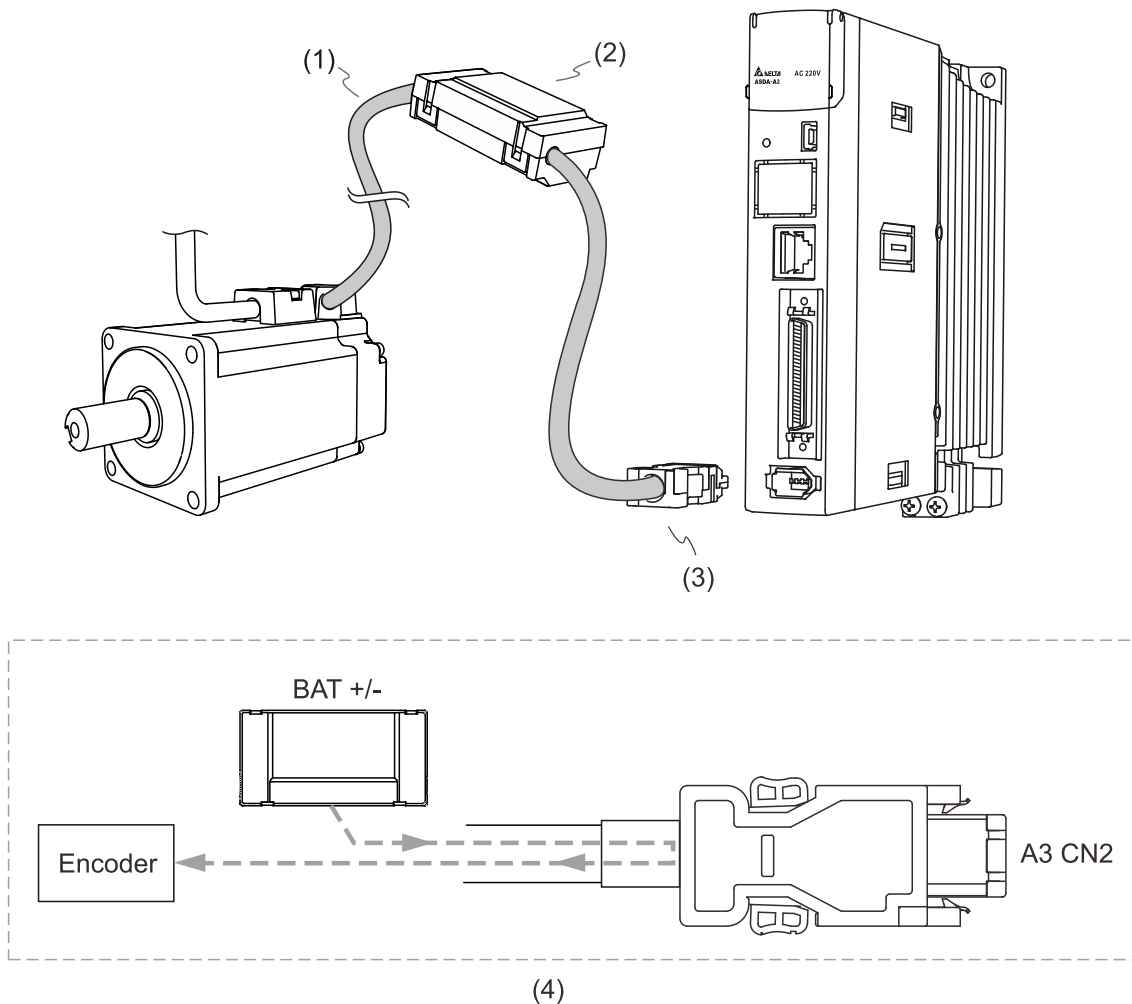

(1) Encoder cable from the motor side; (2) Single battery box;  
 (3) CN2 connector; (4) Battery box wiring

Pin assignment of the connectors:

Encoder cable connector (female)							CN2 of servo drive		Description
Motor with cables				Motor with bulkhead connectors		Pin No.	Signal		
ECMC military	B3 military	CHOGORI	Standard	Color	Bulkhead			Color	
S	4	4	7	Brown	3	Red	1	+5V	+5V power supply
R	9	3	8	Blue	4	Orange	2	GND	Power ground
-	-	-	-	-	-	-	3	CLOCK+	<b>DO NOT connect these pins. They are for third party motors and internal use only.</b>
-	-	-	-	-	-	-	4	CLOCK-	
A	1	1	1	White	1	Blue	5	T+	Serial communication signal (+)
B	2	2	4	White/Red	2	Purple	6	T-	Serial communication signal (-)
L	10	8	9	-	7	-	Case	Shielding	Shielding
C	6	6	2	Red	5	Brown	-	-	+3.6V battery
D	5	5	5	Black	6	Black	-	-	Battery ground

Note:

1. When an absolute encoder is used, the battery supplies power directly to the encoder. Thus, wiring the battery wires to the CN2 connector of the servo drive is not required. For the wiring details of the absolute encoder connectors, refer to Section 3.1.5 Encoder cable and connector specifications.
2. Pin 3 and Pin 4 of the servo drive CN2 connector are for third-party motors and internal use only. Refer to Section 11.2.3.3 Pin assignment of communication type motors.

10

Dual battery box (connects to CN2)

10

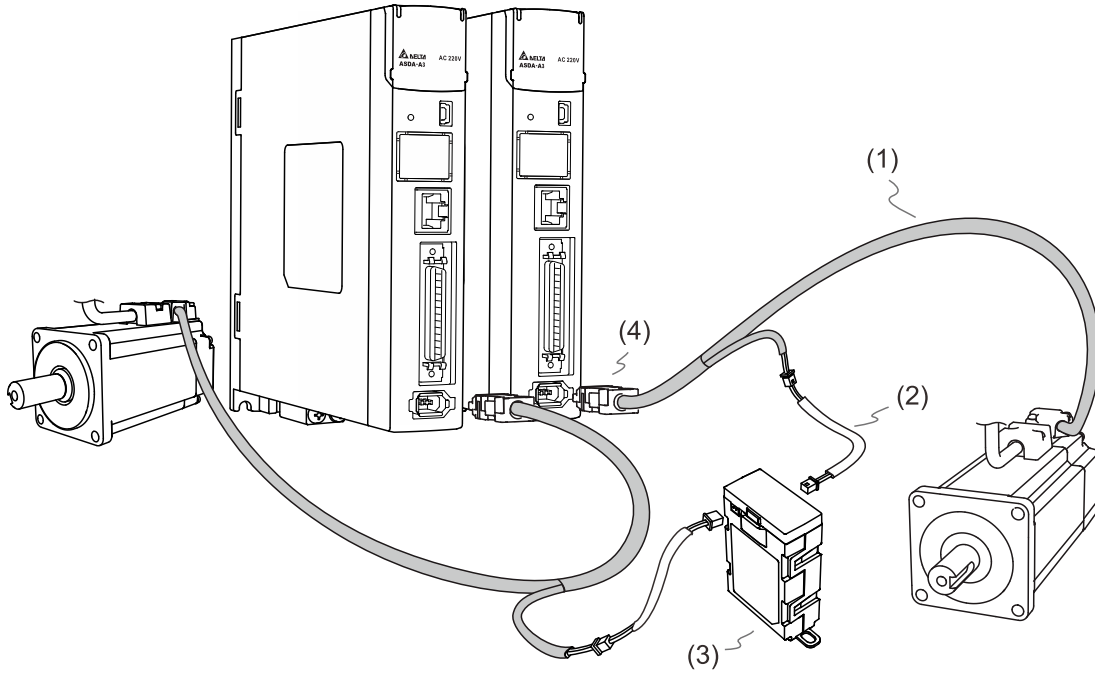

(1) Absolute encoder cable; (2) Battery box cable (one male end and one female end);

(3) Dual battery box; (4) CN2 connector

## 10.2.2 Installing and replacing batteries

### Single battery box

10

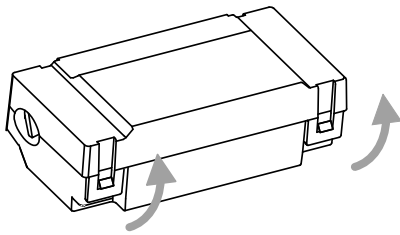

#### Step 1:

Release the snap-fit tabs on both sides and remove the battery box cover.

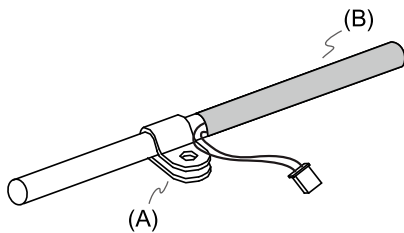

#### Step 2:

Position the cable clamp to the encoder cable. Note that the cable clamp should be placed close to the heat shrink.

(A) Cable clamp; (B) Heat shrink

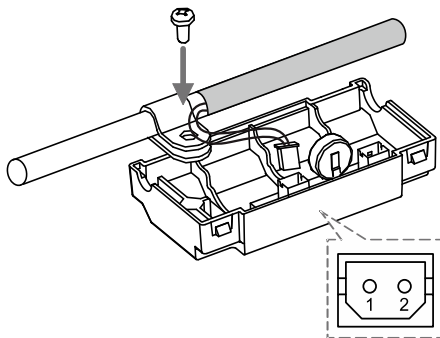

#### Step 3:

Plug in the battery box cable and tighten the cable clamp screw.

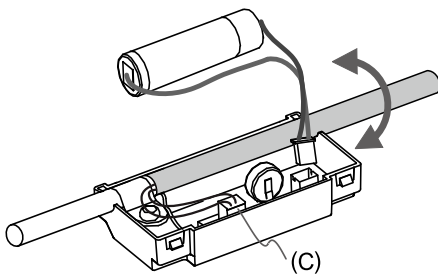

#### Step 4:

Install a new battery and plug in the battery connection wire.

(C) Replace the battery only when the main power to the servo drive is on. Do not remove the battery box cable which connects to the servo drive, or else the system may lose data.

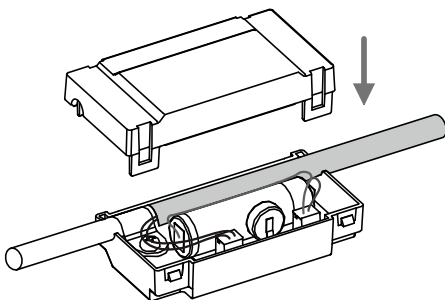

#### Step 5:

Place the battery connection wire into the box and fit the cover.

10

Dual battery box

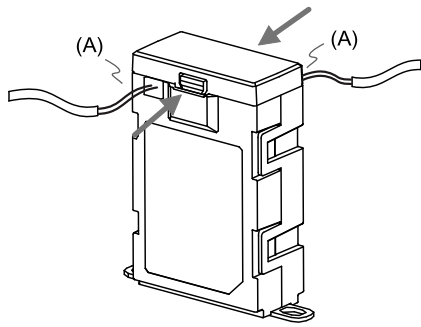

Step 1:

Release the snap-fit tabs on both sides and remove the battery box lid.

(A) Replace the batteries only when the main power to the servo drive is on. Do not remove the battery box cables which connect to the servo drive, or else the system may lose data.

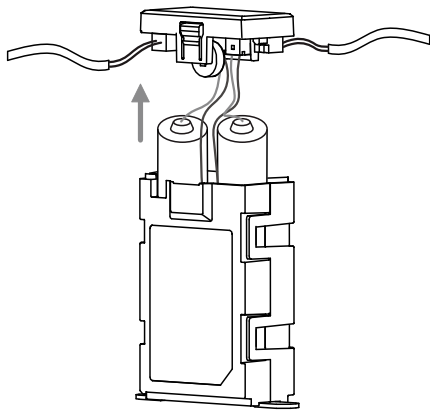

Step 2:

Lift the lid and pull out the batteries.

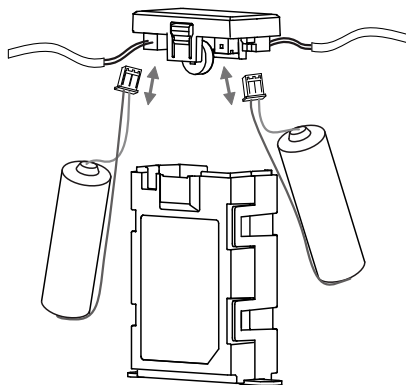

Step 3:

Disconnect the connectors to remove the used batteries. Plug in the connection wire of the new batteries. Replace the new batteries within ten minutes to avoid data loss.

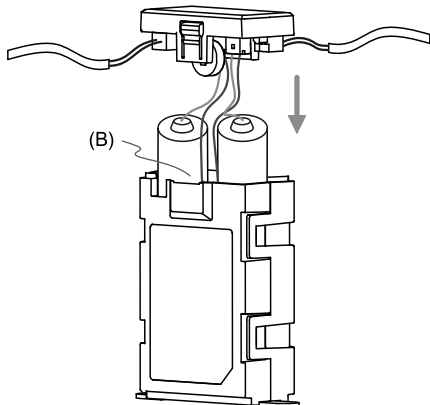

Step 4:

Fit the lid.

(B) Place the battery connection wires toward the inside of the box so that the batteries both fit inside the box.

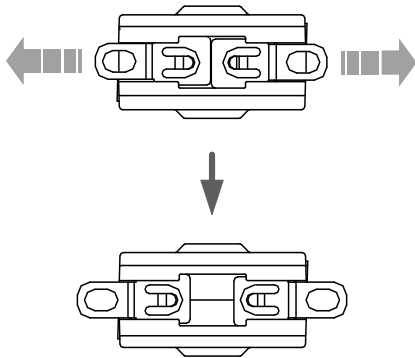
**Step 5:**

Pull the clips at the bottom of the battery box outwards.

10

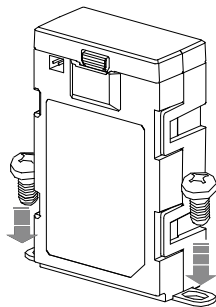
**Step 6:**

Tighten the screws to secure the battery box.

**Note:**

To avoid data loss, replace the battery when any of the following circumstances occurs:

1. The servo drive shows AL061 which means the voltage is too low. Refer to Chapter 14 for more information.
2. Use P0.002 (monitoring variable 26h) to check the battery power. When it displays 31, it means the voltage is under 3.1V.

**Caution:** when the voltage is under 2.7V, the motor's position record may be lost so you need to re-establish the absolute origin position after installing new batteries. It is suggested that you replace the batteries when the main power to the servo drive is on to avoid loss of absolute position data.

## 10

## 10.3 System initialization and operating procedures

### 10.3.1 System initialization

AL06A occurs when you initialize the absolute system for the first time because the position system has not been established. Clear the alarm by setting up the position system. When insufficient battery power or interruption of battery power causes loss of the position system, AL060 occurs. In the absolute system, the position data is within a specific range. When the number of motor revolutions exceeds the range of -32,768 to +32,767, AL062 occurs. When the PUU position value exceeds the range of -2,147,483,648 to +2,147,483,647, AL289 occurs.

In addition to the preceding alarms (enabled by default), you can use P2.070 [Bit 2] to set whether to show AL062 and AL289 if the absolute position system overflows (the number of revolutions exceeds the range of -32,768 to +32,767 or the PUU number exceeds the range of -2,147,483,648 to +2,147,483,647). This function is for systems which use incremental commands to operate in a single direction.

P2.070 setting:

1. Establish the absolute origin position. When the position setting is complete, AL06A (or AL060) is automatically cleared. There are two representations for the controller to establish the absolute origin position: pulse number and PUU number. You can establish the absolute origin position with DI/DO, parameters, or the PR homing function.
2. When the system is powered on again, the controller can access the motor's absolute position either with DI/DO or communication. Based on the setting of P2.070, the controller can read the position value in PUU (refer to Section 10.3.3) or the number of revolutions plus the pulse number within a single revolution (refer to Section 10.3.2).

### 10.3.2 Pulse number

When the motor is running in the clockwise direction, the number of revolutions is defined as a negative value. When the motor runs in the counterclockwise direction, the number of revolutions is defined as a positive value. The range of the countable number of revolutions is between -32,768 and +32,767. AL062 occurs once the overflow of number of revolutions occurs (which means the number exceeds the range). To clear the alarm, you must re-establish the absolute origin position. If P2.070 has been set not to show the AL062 alarm, then the system ignores the overflow of number of revolutions.

If the motor is operating in the counterclockwise direction and the number of revolutions reaches 32,767, the value jumps to -32,768 once the motor reaches the target position in the next turn, and the value keeps increasing from -32,768 to +32,767. If the motor is operating in the clockwise direction and the number of revolutions reaches -32,768, the value jumps to +32,767 once the motor reaches the target position in the next turn, and the value keeps decreasing from +32,767 to -32,768.

In addition, there are 16,777,216 pulses (0 to 16,777,215) in one revolution. Pay attention to the motor's running direction. You can read the number of revolutions and the pulse number within a single turn with either communication or DI/DO.

Total pulse number = m (number of revolutions) x 1,677,7216 + pulse number within a single turn (0 to 16,777,215).

The conversions between pulse number and PUU are as follows:

When P1.001.Z = 0: the PUU number when power on = pulse number x  $\frac{P1.045}{P1.044}$  + P6.001.

When P1.001.Z = 1: the PUU number when power on = (-1) x pulse number x  $\frac{P1.045}{P1.044}$  + P6.001.

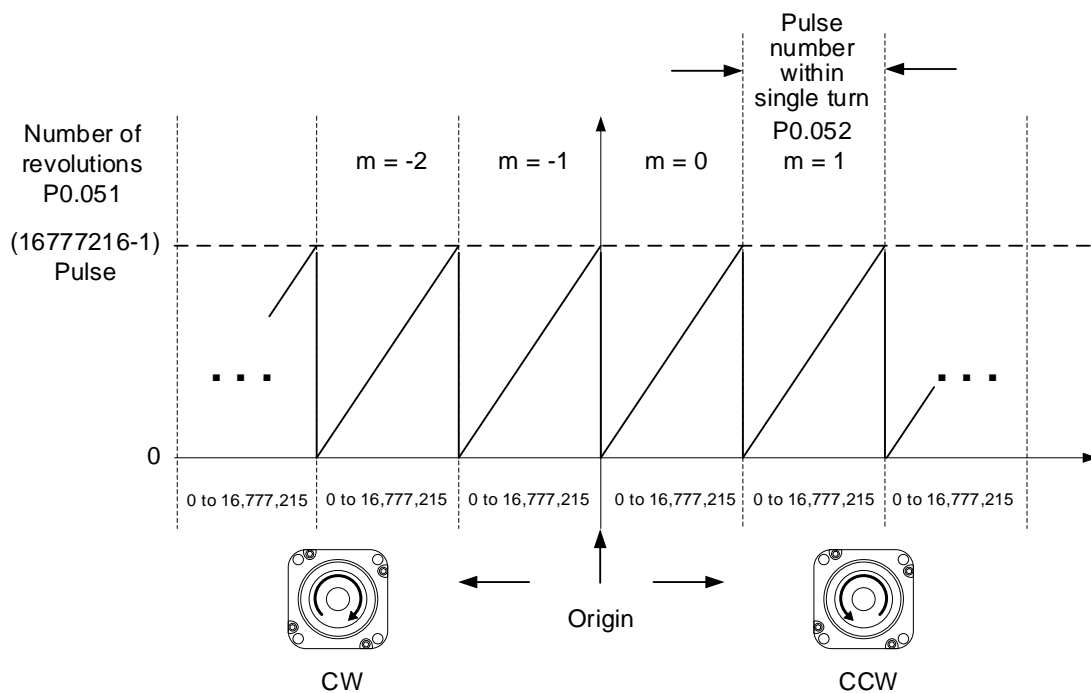

Figure 10.3.2.1 Absolute position for pulse number



# 10

### 10.3.3 PUU number

The PUU number is a 32-bit absolute position data with a positive or negative sign. When the motor is operating in the positive direction, the PUU number increases; when the motor is operating in the negative direction, the PUU number decreases. The motor operation direction (positive / negative) is defined by P1.001.Z; operation in the clockwise direction does not necessarily mean the motor is operating in the positive direction.

If the motor keeps operating in the same direction and the number of revolutions exceeds the range of -32,768 to +32,767, the servo drive generates AL062. If the motor's PUU number exceeds the range of -2,147,483,648 to +2,147,483,647, the servo drive generates AL289 (Position counter overflows). When an overflow issue of the absolute encoder (AL062 or AL289) occurs, re-establish the absolute origin position to clear the alarm. You can also set P2.070 to determine whether the servo drive generates the alarms AL062 and AL289 when an overflow occurs. If the motor is operating in the positive direction and the absolute position data reaches +2,147,483,647 PUU, the value jumps to -2,147,483,648 in the next turn, and the value keeps increasing from -2,147,483,648 to +2,147,483,647. If the motor is operating in the negative direction and the absolute position data reaches -2,147,483,648 PUU, the value jumps to +2,147,483,647 in the next turn, and the value keeps decreasing from +2,147,483,647 to -2,147,483,648. See the following examples:

**Example 1:**

When P1.044 = 16777216 and P1.045 = 100000, the motor needs 100,000 PUU to run one revolution.  $2147483647 \div 100000 \approx 21474.8$ , so once the motor runs over 21,474.8 (< 32767) revolutions in the positive direction, AL289 occurs.

**Example 2:**

When P1.044 = 16777216 and P1.045 = 10000, the motor needs 10,000 PUU to run one revolution.  $2147483647 \div 10000 \approx 214748.3$ , so once the motor runs over 32,767 (< 214748.3) revolutions in the positive direction, AL062 occurs.

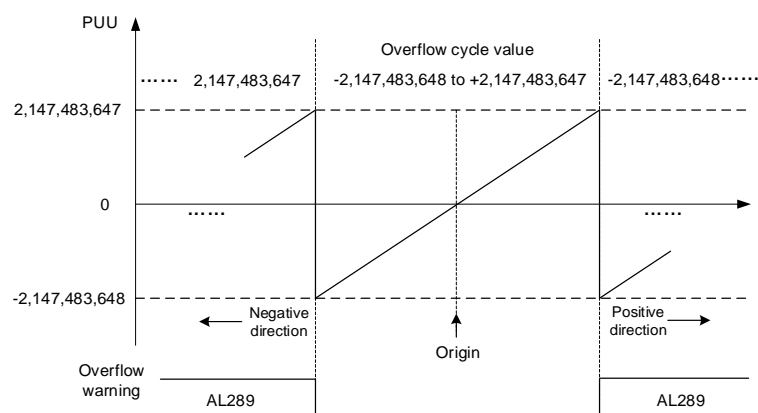

Figure 10.3.3.1 Absolute position for PUU number

Note: after the absolute origin position is established, any change to P1.001.Z or E-Gear ratio (P1.044 and P1.045) changes the original setting of the absolute origin position. If these parameters are changed, re-establish the absolute origin position.

### 10.3.4 Establishing the absolute origin position

When the absolute position is lost, the servo drive provides three methods to establish the absolute origin position: DI/DO, parameter setting, or the PR homing function. The following provides more details for each method.

#### 10.3.4.1 Establishing the absolute origin position with DI/DO

When the servo system is controlled by the controller, establish the absolute origin position with DI/DO. Once the absolute position is established, the pulse number is reset to 0 and the PUU number is reset to the value of P6.001. Refer to the following diagram for detailed descriptions.

Description:

1. When the controller triggers DI.ABSE, it has to wait for  $T_s$  before proceeding to the next step.
2. After reaching  $T_s$ , the controller starts to establish the absolute origin position.  
When DI.ABSC is triggered and remains on for  $T_Q$ , the pulse number is reset to 0 and the PUU number is reset to the value of P6.001.

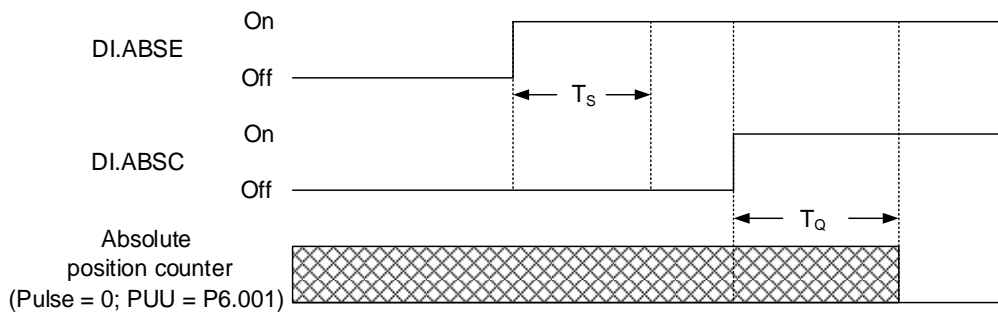

Figure 10.3.4.1.1 Timing diagram for establishing the absolute origin position with DI/DO

The following table describes the  $T_s$  and  $T_Q$  delay time after DI.ABSE and DI.ABSC are switched to On.

	$T_s$ (ms)	$T_Q$ (ms)
Min	P2.009 + 2	
Max	P2.009 + 10	

# 10

### 10.3.4.2 Establishing the absolute origin position with parameters

Set P2.071 to 1 to establish the absolute origin position through the panel or with communication. Since P2.071 is write-protected by P2.008, you must set P2.008 to 271 first. In other words, the sequence is: set P2.008 to 271, and then set P2.071 to 1. As soon as P2.071 is set to 1, the absolute position system resets.

### 10.3.4.3 Establishing the absolute origin position with the PR homing function

You can use the 11 homing modes in the PR mode to establish the absolute origin position. For more details, refer to Section 7.1.3.1 Homing methods.

## 10.3.5 Reading the absolute position

### 10.3.5.1 Reading the absolute position with DI/DO

Set P2.070 [Bit 0] to 0 so that you can read the value in PUU with DI/DO. See the following descriptions.

Bit 79 - Bit 64	Bit 63 - Bit 32	Bit 31 - Bit 16	Bit 15 - Bit 0
Check Sum	Encoder PUU -2,147,483,648 to +2,147,483,647	0	Encoder status (P0.050)

Set P2.070 [Bit 0] to 1 so that you can read the value in pulse with DI/DO. See the following descriptions.

Bit 79 - Bit 64	Bit 63 - Bit 32	Bit 31 - Bit 16	Bit 15 - Bit 0
Check Sum	Encoder pulse number within one revolution 0 to 16,777,215 (= 16,777,216 - 1)	Number of encoder revolution -32,768 to +32,767	Encoder status (P0.050)

Description:

$$\text{Check Sum} = ((((((\text{WORD}_0 + 0xA700) \text{ XOR } \text{WORD}_1) + 0x605A) \text{ XOR } \text{WORD}_2) + 0x30A5) \text{ XOR } \text{WORD}_3) + 0x5A06)$$

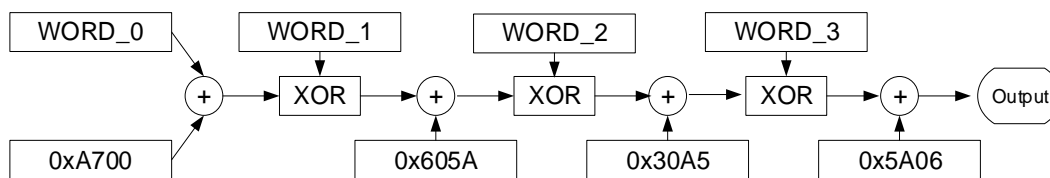

Note:

1. This algorithm has no positive or negative sign.
2. 0xA700, 0x605A, 0x30A5, and 0x5A06 are constants in hexadecimal format.
3. WORD\_0: encoder status (Bit 15 - 0)  
 WORD\_1: number of encoder revolution (Bit 31 - 16)  
 WORD\_2: encoder pulse number (Bit 47 - 32)  
 WORD\_3: encoder pulse number (Bit 63 - 48)

You can set P2.070 to read the position value in the unit of pulse or PUU with DI/DO.

See the following timing diagram.

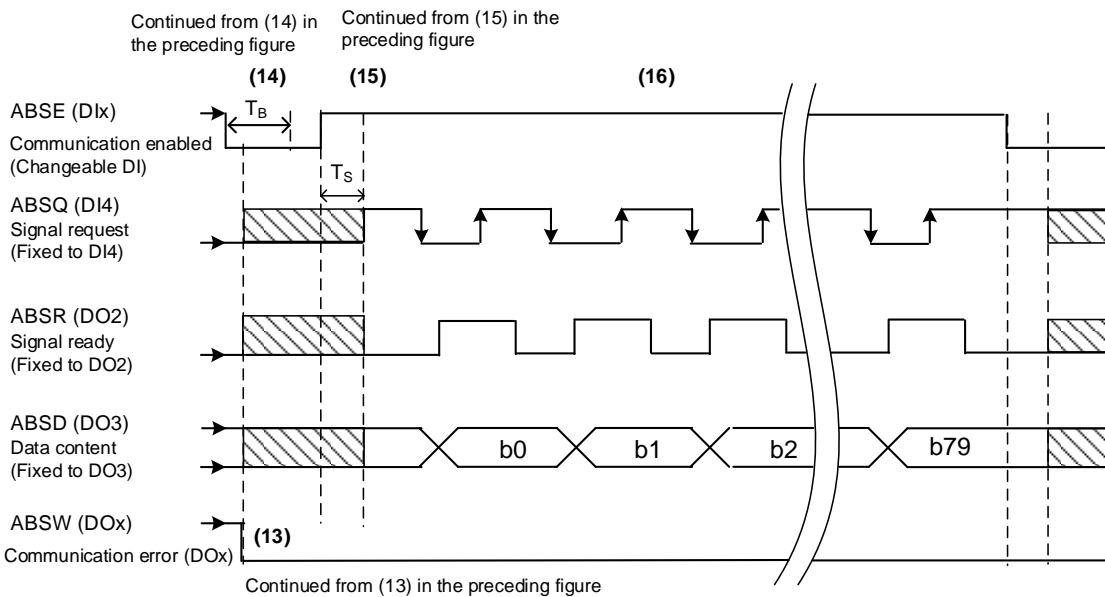
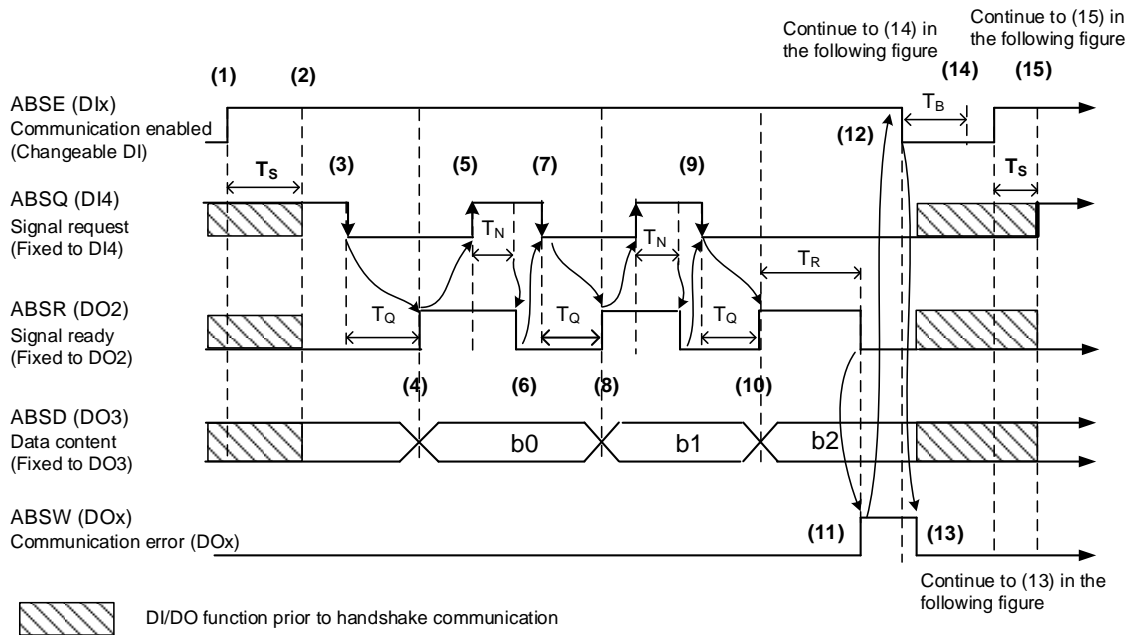

Figure 10.3.5.1.1 Timing diagram for reading the absolute position with DI/DO

The following table describes the delay time when the absolute position is read with DI/DO.

	$T_R$ (ms)	$T_S$ (ms)	$T_Q$ (ms)	$T_N$ (ms)	$T_B$ (ms)
Min.	-		P2.009 + 2		
Max.	200		P2.009 + 10		

## 10

## Descriptions:

- (1) When the handshake communication starts, the ABSE signal is triggered.
- (2) After the  $T_s$  delay time (make sure the ABSE signal is On), the functions for DI4, DO2, and DO3 are switched to ABSQ, ABSR, and ABSD, respectively. If DI4 was in the high-level state before, it remains in the high-level state when switched to ABSQ (logic high-level signal). DI4, DO2, and DO3 are dual-function DI/DOs, which means the set functions for DI4, DO2, and DO3 share the same DI/DOs with ABSQ, ABSR, and ABSD. Pay special attention when switching their functions before, during, or after the signal handshake. To set these three DI/DOs as single function, set them to 0 before switching the functions.
- (3) If DI4 was in the high-level state and switched to ABSQ after the  $T_s$  delay time, when the controller resets this signal to low level, the new signal is interpreted as the data access command.
- (4) After the  $T_Q$  time, the handshake data is ready and the absolute position is sent to ABSD. Now the servo drive triggers the ABSR signal and the controller can access the data. If the controller cannot detect the ABSR status while it is changing to high level after the maximum  $T_Q$  time (refer to Figure 10.3.5.1.1), there may be a communication error such as communication cable disconnection.
- (5) Once the ABSR signal is set to high level, the controller accesses the data, and the ABSQ signal is set to high level to notify the servo drive that data was read.
- (6) When ABSQ is at high level, ABSR is set to low level after the  $T_N$  time in order to send the data for the next bit communication.
- (7) When ABSR is at low level, ABSQ is also set to low level and the servo drive needs to send the data for the next bit communication.
- (8) Repeat steps 3 and 4. Send the absolute position to ABSD for the next bit communication.
- (9) Repeat steps 5 to 7. The controller has read and received the data.
- (10) The third bit data is ready.
- (11) After the  $T_R$  waiting time, if the controller has not read the data and triggered the ABSQ signal, the servo drive sends the ABSW signal (communication error) and stops the handshake communication.
- (12) When the controller receives the communication error signal, it sets ABSE to low level and prepares to restart the handshake communication.
- (13) ABSW resumes to low level after the servo drive receives the ABSE signal.
- (14) The controller resumes communication after the  $T_B$  time.
- (15) Repeat step 1.
- (16) If no error occurs, the controller completes 80 bits (0 - 79) of the handshake communication with the servo drive. DI4, DO2, and DO3 then resume their original functions.

Note: if ABSE is set to low level first and then changed to high level, but ABSW does not resume to high level and the alarm remains on, it means some other errors exist. Check for the following possible warnings: absolute position lost, low battery voltage level, or absolute position overflows. Restart a new communication cycle after those errors have been cleared.

### 10.3.5.2 Reading the absolute position with communication

You can access the data of the absolute encoder through two communication methods: instant access or register access.

#### Instant access

Instant access refers to reading the motor's feedback position as soon as power is supplied to the servo. When you set the status monitoring register 1 to the motor's feedback pulse number (P0.017 = 0), you can access the motor's current position by reading P0.009.

#### Register access

Register access means the motor's position is temporarily stored in the register and the read value does not change with the motor's movement. Once you set P0.049 with communication, the encoder status and motor absolute position (number of revolutions), and pulse number (or PUU) are stored in P0.050, P0.051, and P0.052 respectively. You can set to read the value in the unit of pulse or PUU with P2.070 [Bit 1].

- When P0.049 is set to 1, the drive does not clear the position error when reading the position value.
- When P0.049 is set to 2, the drive clears the position error at the same time when reading the position value. After the motor is enabled, it moves slightly forward and backward to correct its position even it is stopped. To avoid the difference between the actual and read motor positions, set P0.049 to 2 to have the motor's actual position updated to the servo drive, which clears the position error.

For example, the motor's current position is 20000, but it varies between 19999 and 20001. If you send the command to read the motor's position when it stops at 20001, the read value is 20001. Meanwhile, 20001 is updated to the servo drive, meaning the position error is cleared. If the servo drive does not update the read position, a command error occurs.

# 10

- After all position data is updated in P0.050 - P0.052, P0.049 is automatically reset to 0. At that point, the controller can access the values of P0.050 - P0.052.
- P0.050 shows the status of the absolute encoder. When the status shows “absolute position lost” or “overflow of number of revolutions”, it means the read absolute position is invalid. In this case, you must re-establish the absolute origin position.

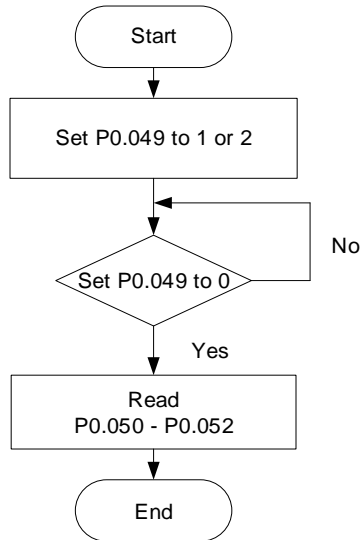

## 10.4 Parameters, DI/DO, and alarms related to absolute function

Relevant parameters (refer to Chapter 8 for detailed information):

Parameter	Function
P0.002	Drive status
P0.049	Update encoder absolute position
P0.050	Absolute position system status
P0.051	Encoder absolute position - number of revolutions
P0.052	Encoder absolute position - pulse number or PUU within single turn
P2.069	Absolute encoder
P2.070	Read data selection
P2.071	Absolute position reset

10

Relevant DI/DO (refer to Chapter 8 for detailed information):

Setting value	DI name	Setting value	DO name
0x1D	ABSE	When DI.ABSE is on, DO.ABSR triggered by DO2 will replace the DO2 assigned by P2.019.	ABSR always output by DO2
When DI.ABSE is on, the DI.ABSQ from DI4 replaces the DI4 function from P2.013.	ABSQ always input by DI4	When DI.ABSE is on, DO.ABSD triggered by DO3 will replace the DO3 assigned by P2.020.	ABSD always output by DO3
0x1F	ABSC	0x0D	ABSW

Relevant alarms (refer to Chapter 14 for detailed information):

Display	Alarm name
AL060	Absolute position is lost
AL061	Encoder undervoltage
AL062	Number of revolutions of the absolute encoder overflows (issued by encoder)
AL069	Wrong motor type
AL072	Encoder overspeed
AL073	Encoder memory error
AL074	Encoder single-turn absolute position is in error
AL075	Encoder absolute number of revolutions is in error
AL077	Encoder internal error
AL079	Encoder parameter setting incomplete
AL07B	Encoder memory is busy
AL07C	Command to clear the absolute position is issued when the motor speed is over 200 rpm
AL07D	Motor stops operating when servo drive power is cycled before AL07C is cleared
AL07E	Error occurs when the encoder clears the procedure
AL289	Position counter overflows



(This page is intentionally left blank.)

10

# Linear Motor and Third-Party Motor

# 11

This chapter provides the usage and setting details for the linear motors and third-party motors.

11.1	Linear motor overview	11-3
11.2	Installation and configuration	11-4
11.2.1	Precautions for installing linear motors	11-4
11.2.2	Configurations for linear motors and rotary motors	11-7
11.2.2.1	Peripheral configuration for pulse type motors	11-8
11.2.2.2	Peripheral configuration for pulse type and sine wave type motors	11-9
11.2.2.3	Peripheral configuration for Delta motors and third-party communication type motors	11-10
11.2.3	Communication type motors	11-11
11.2.3.1	Third-party communication type motors	11-11
11.2.3.2	Supported communication format for the motors	11-12
11.2.3.3	Pin assignment of communication type motors	11-12
11.3	Complete the settings for linear motors and third-party motors with ASDA-Soft	11-13
11.3.1	Motor parameter identification	11-14
11.3.1.1	Motor parameter identification for linear motors	11-15
11.3.1.2	Motor parameter identification for rotary motors	11-22
11.3.2	Linear motor direction setting	11-29
11.4	Linear encoder	11-30
11.5	Hall sensor	11-31
11.5.1	Installing the Hall sensor	11-32
11.5.2	Checking the Hall sensor phase sequence	11-33
11.6	Position signal converter box	11-34
11.6.1	Specifications of position signal converter box	11-34
11.6.2	Interface of position signal converter box	11-35
11.6.3	Pin assignment of position signal converter box	11-36
11.7	Linear motor parameter setting	11-37
11.7.1	Total weight (mover + load)	11-37
11.7.2	E-Gear ratio	11-37

11.7.3 Limit setting ..... 11-37  
11.7.4 Current setting for initial magnetic field detection..... 11-38  
11.7.5 Overload gain..... 11-39

# 11

### 11.1 Linear motor overview

Linear motor can directly convert electrical energy into linear kinetic energy, and its mover and stator structures are different from those of a permanent-magnet rotary motor. The use of a linear motor reduces the number of parts used in the machine. The direct drive method not only eliminates backlash, but also reduces the complexity of the machine and improves reliability.

The linear motor drive speed is faster than the rotary motor connected to the ball screw. In applications with longer stroke, be aware that the ball screw being too long causes the screw to droop and creates more friction, which results in wearing of the screw. The linear motor adopts a modular design which can connect to unlimited number of modules, so there are relatively few restrictions on the stroke.

The linear motor uses the linear scale or magnetic scale to get the feedback position instead of the rotary encoder in the rotary motor. When a linear motor is used, it is recommended that you install a Hall sensor and temperature sensor. The temperature sensor can directly monitor the actual temperature of the linear motor, providing further protection for the motor. For more information about the Hall sensor, refer to Section 11.5.

Note: for the Hall sensor setting, refer to PM.003 in Chapter 8; for the temperature sensor setting, refer to PM.022 in Chapter 8.

Linear motor

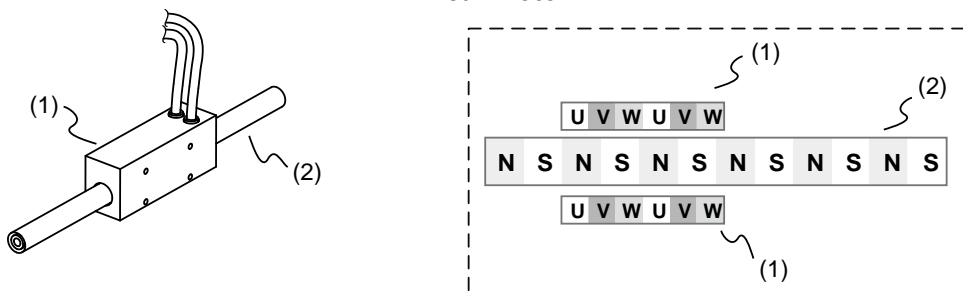

Flat type (iron core) linear motor

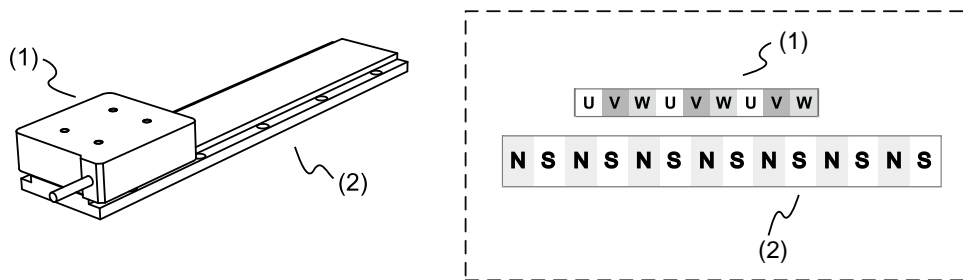

U-shaped linear motor

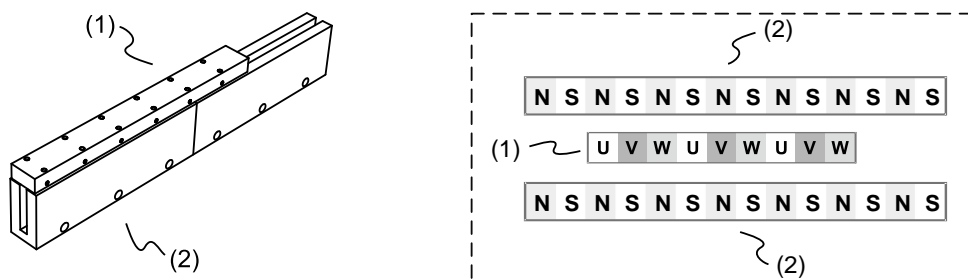

## 11.2 Installation and configuration

### 11.2.1 Precautions for installing linear motors

The Delta linear motor is designed for industrial applications. It is necessary that you fully read the motor specifications and operation manual. For your safety and correct use of the linear motor, read the precautions carefully before connecting the motor to any equipment.

The safety precautions are as follows:

#### Handling, mounting, and storage

- When removing or placing the coil assembly of the linear motor, do not drag the cable.
- Do not hit the coil assembly. Impact force will damage the coil assembly and the wiring ends.
- Do not remove or place the magnet shaft of the linear motor near any magnetic objects; otherwise, the magnet shaft may be demagnetized. Make sure the assembly procedure for the magnet shaft is complete before you proceed to the next assembly step.
- Do not hit the magnet shaft. Impact force will damage the magnets.
- The mover of the flat type linear motor is iron core. During installation, keep a distance of at least 30 cm (11.8 inches) between the iron core mover and the magnet shaft to avoid attractions, which may cause personnel injury.
- Do not touch the linear motor during operation because its temperature is high. If you need to disassemble the linear motor, power off the motor and wait for the motor to cool down before disassembling.
- The magnet shaft has ferromagnetism, so avoid using tools or screws that are magnetic; otherwise, it may cause personnel injury when the magnet shaft attracts the tools or screws.
- Use a torque wrench when fastening the screws and set the tightening torque based on the screw size.
- The coil assembly and magnet shaft of the linear motor are neither waterproof nor oilproof. Do not store, install, or use the linear motor in an environment that contains water, oil liquids, corrosive and inflammable gases, or is with high humidity.
- The material of the coil assembly is not rustproof. Although rustproof oil has been applied to the coil assembly during the manufacturing process, you must check the coil assembly condition and apply rustproof oil every three months if storing the motor for more than six months.
- Ensure that the environmental conditions for storing the linear motor conform to the specifications in the instruction sheet.

- When the magnet shaft is fixed on two sides, the magnet shaft might be bent due to gravitational force or the magnetic attraction caused by the base, especially during long distance operation. Refer to the following figure.

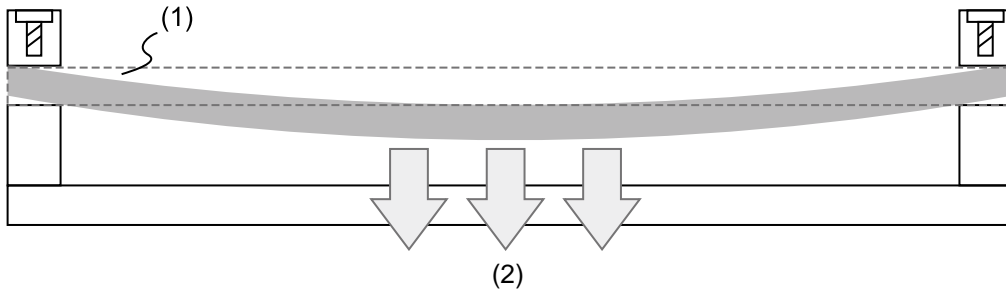

(1) Magnet shaft; (2) Magnet shaft might be bent due to gravitational force or the force of magnetic attraction

- When the magnet shaft bends out of tolerance, it may touch the coil assembly and cause intermittent friction. Insert two pieces of sheet metal to the fixed points of the shaft or adjust the fixing angle of the shaft on two sides to offset the bending deformation, as shown in the following figure.

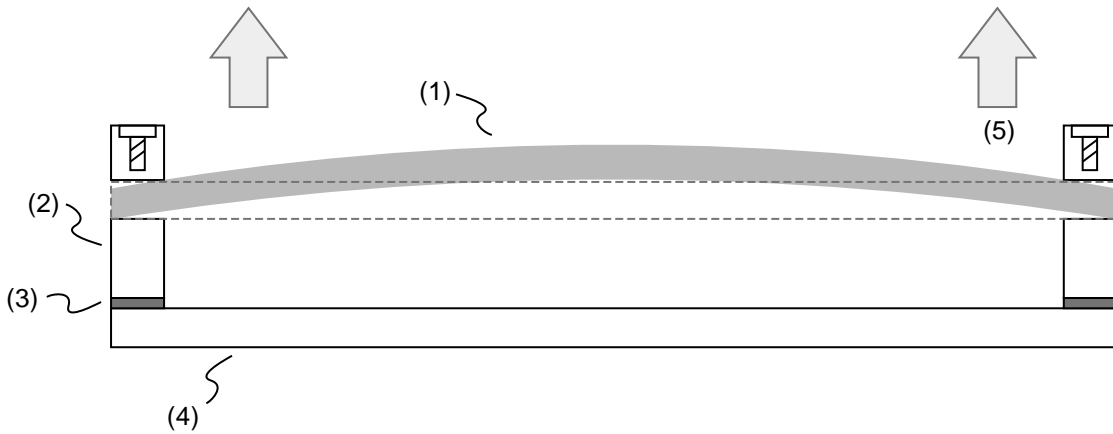

(1) Magnet shaft; (2) Shaft support; (3) Sheet metal; (4) Base; (5) Two fixing sides of the shaft are slightly bent upward

**Wiring**

- If the current exceeds the maximum current in the specifications, the coil assembly of the linear motor may overheat, and thus be damaged. Contact the distributor or local Delta sales representative if this problem occurs.
- Make sure the wiring of the linear motor is correct. Incorrect wiring will lead to abnormal operation, malfunction, or damage of the linear motor.
- The linear motor must be correctly grounded.
- When the linear motor is undergoing high-voltage component tests, cut off the power supply to the controller. To maintain the product lifespan, do not perform this kind of test unless necessary.

**Operation**

- Use the servo drives which are designed for driving the linear motors. Do not directly connect a commercial type power supply (100/200V, 50/60 Hz) to the linear motor circuit; otherwise the motor cannot operate normally and may be permanently damaged.
- Make sure there is no obstacle between the coil assembly and the magnet shaft.
- Follow the linear motor specifications when using the product. The motor's operation temperature must not exceed the specified range.
- If there is any odor, noise, smoke, heat, or abnormal vibration during motor operation, stop the motor and turn off the power immediately.
- When the linear motor is operating, reserve an air gap between the coil assembly and the magnet shaft according to the specifications. When the air gap is too large, it might lower the motor performance; when the air gap is too small, the assembly coil might be in contact with the magnet shaft.

**Other precautions**

- Delta linear motors have no user-replaceable parts.
- Do not disassemble the linear motor or replace its parts, or it will void the warranty.
- Disassembling the linear motor may lead to permanent malfunction or damage of the motor.
- Do not splash any water or oil on the product.

**Air gap specification**

- To ensure the thrust is normal, pay attention to the assembly height of air gap between the coil assembly and magnet shaft, and refer to the geometric tolerance between the assembly parts to make sure the coil assembly and the magnet shaft make no contact.

### 11.2.2 Configurations for linear motors and rotary motors

The configurations for linear motors and rotary motors are as follows.

Rotary motor					
Feedback signal source	CN2				CN5
Supported signal	Delta communication type	Pulse	Sine wave	Third-party communication type	Pulse
Whether to use the position signal converter box	No	Yes	Yes	No	No
Whether to execute motor parameter identification	No	Yes	Yes	Yes	All motors except C8 require motor parameter identification.

Note: when using a Delta ECMA-C8 motor, set PM.003 to 0x1002 and cycle the power before use.

Linear motor					
Feedback signal source	CN2				CN5
Supported signal	Delta communication type*	Pulse	Sine wave	Third-party communication type	Pulse
Whether to use the position signal converter box	No	Yes	Yes	No	No
Whether to execute motor parameter identification	No	Yes	Yes	Yes	Yes

Note: Delta communication type linear motor is coming soon.

#### Pulse signal

1. The pulse signals can be input through the CN5 connector of the servo drive. Refer to Section 11.2.2.1 for details.
2. The pulse signals can also be converted to Delta’s communication format with the position signal converter box and input through CN2. Refer to Section 11.2.2.2 for details.

#### Sine wave signal

The sine wave signals can be input through CN2 only after being converted to Delta’s communication format with the position signal converter box. Refer to Section 11.2.2.2 for details.

#### Communication format

The CN2 connector of the servo drive supports specific communication formats (BiSS C, Mitutoyo, Endat2.2, Fagor, Tamagawa, and Nikon) and Delta’s communication format. Refer to Section 11.2.2.3 for details.



11.2.2.1 Peripheral configuration for pulse type motors

11

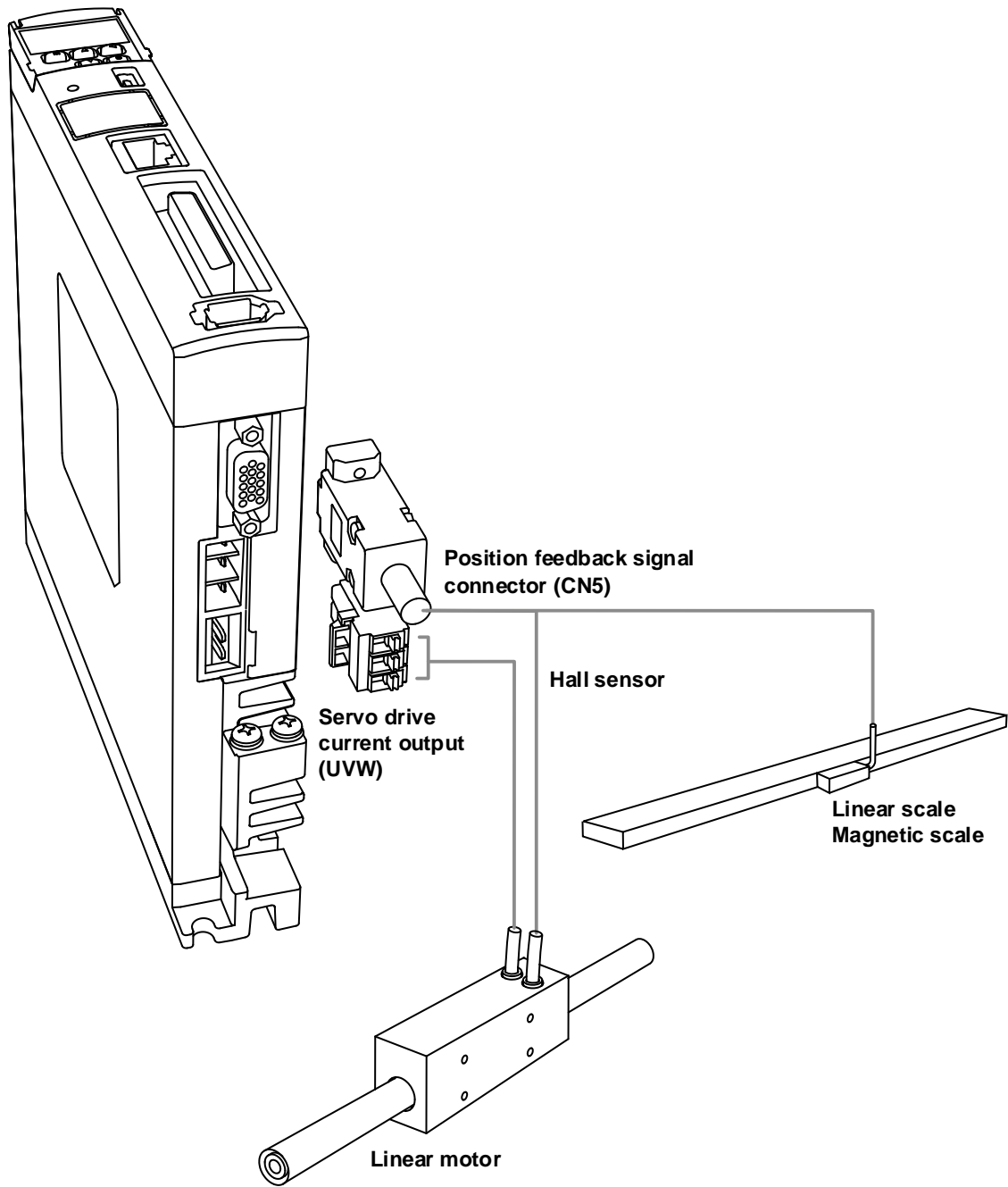

11.2.2.2 Peripheral configuration for pulse type and sine wave type motors

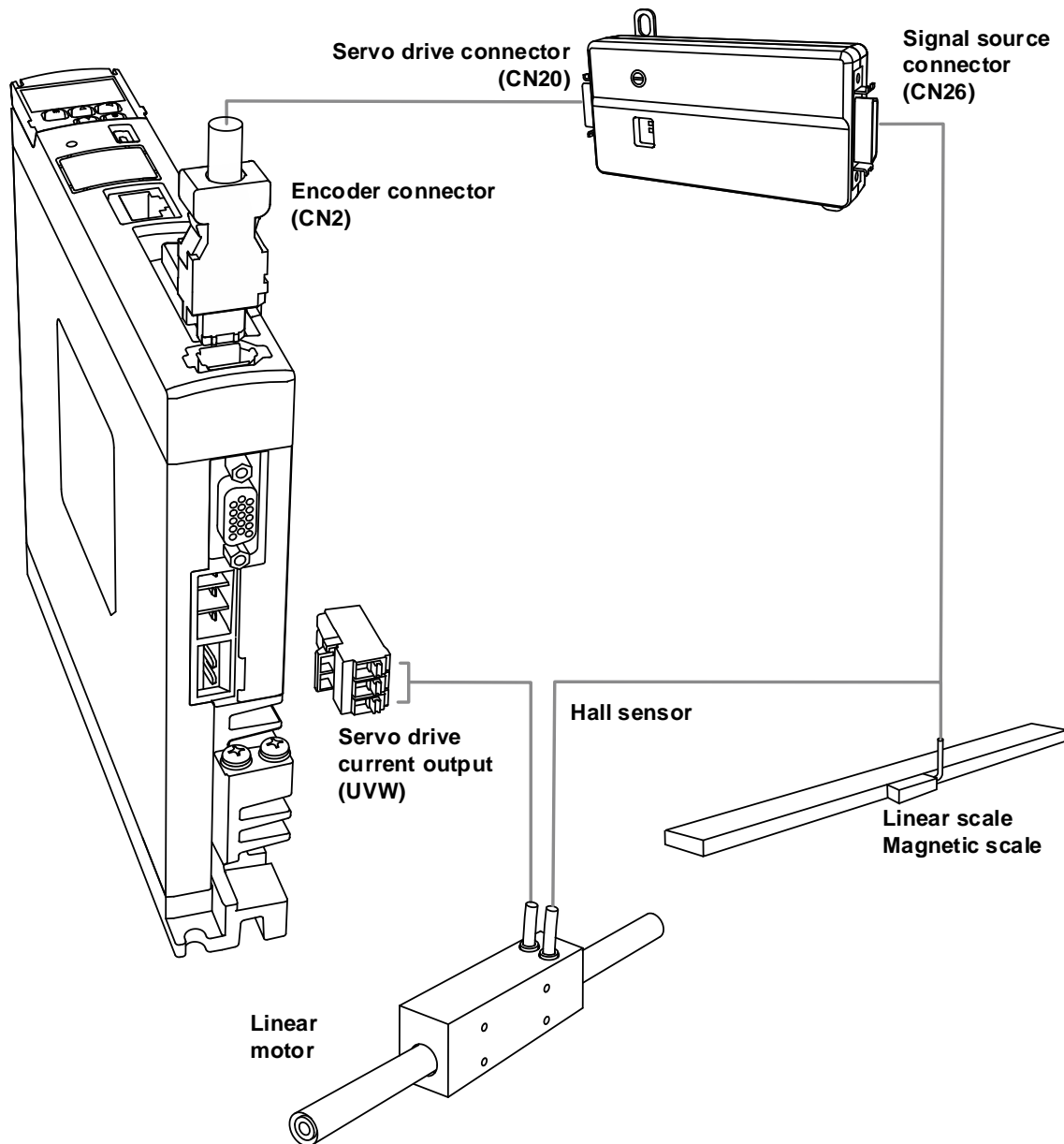

Note: refer to Section 11.6 for the wiring of the position signal converter box.

### 11.2.2.3 Peripheral configuration for Delta motors and third-party communication type motors

11

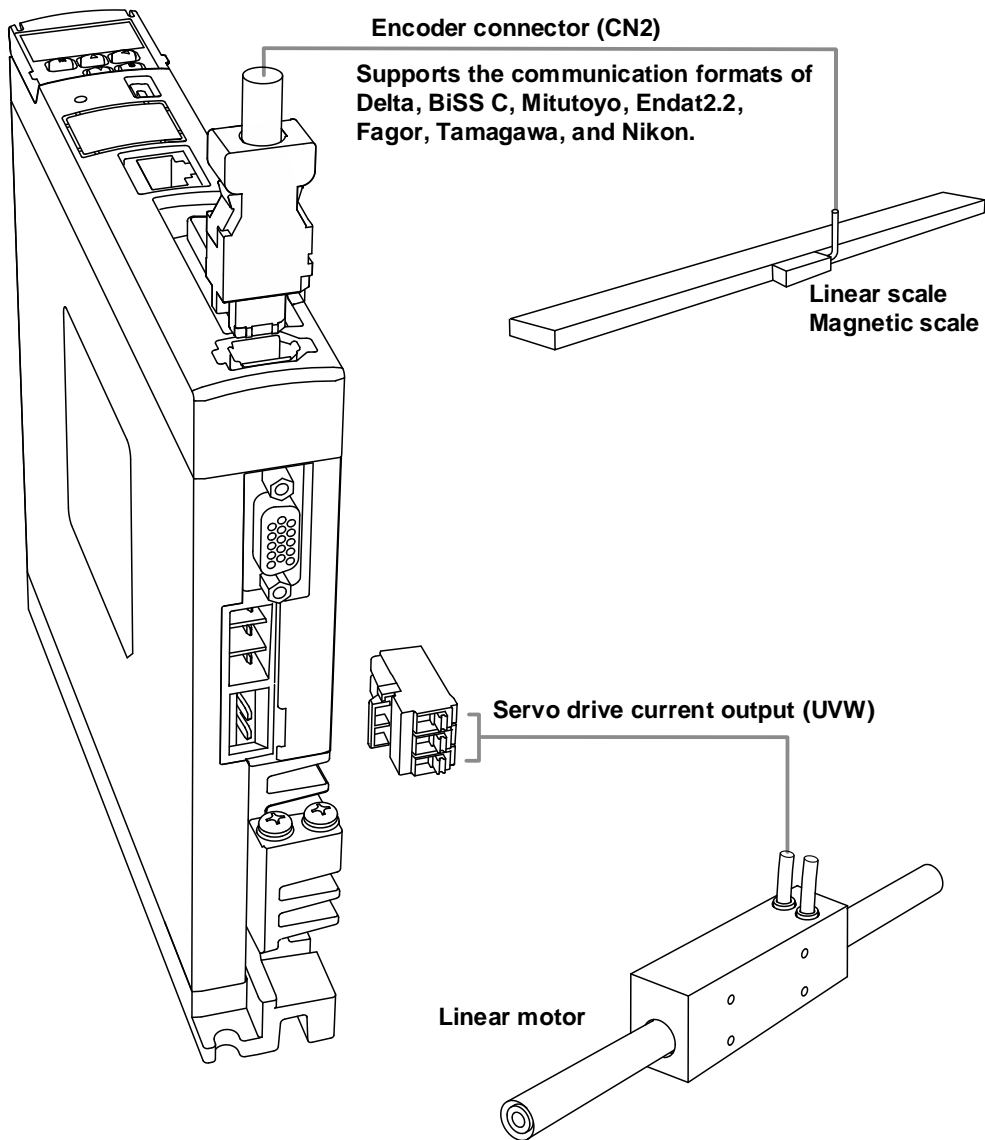

Note: refer to Section 11.2.3.3 for the pin assignments of the third-party communication type motors.

## 11.2.3 Communication type motors

### 11.2.3.1 Third-party communication type motors

ASDA-A3 supports communication formats<sup>\*1</sup> for the third-party encoders, including BiSS C, Mitutoyo, Endat2.2, Fagor, Tamagawa, and Nikon.

The maximum resolution of the encoders supported by the servo drive is as follows. Encoders with the resolution higher than the following specification are not supported.

Linear scale: 1 nm/pulse

Rotary encoder: 30-bit

When the CN2 connector of the servo drive is configured in the following three ways and AL011 is not displayed, execute the Motor Parameter Identification Wizard<sup>\*2</sup> and continue the operation after cycling power to the servo drive.

1. A position signal converter box + a pulse type motor
2. A position signal converter box + a sine wave type motor
3. Connecting with the third-party communication type motor

In addition, follow these instructions.

1. **Replacing the linear scale:** re-import the parameter file and cycle power to the servo drive. Next, execute the Motor Parameter Identification Wizard and cycle power to the servo drive after the identification is complete.
2. **Changing the machine:** even if there are multiple machines with the same mechanical design, you need to import the parameter file for each machine **individually** and then cycle power to the servo drive. Next, execute the Motor Parameter Identification Wizard for each machine and cycle power to the servo drive after the identification is complete.
3. **Changing the motor:** if you need to change to a different motor (a Delta linear motor or a third-party motor of different communication formats), re-configure the Motor Parameter Identification Wizard.
4. When using the absolute function, establish the absolute position of the origin; otherwise sudden unintended acceleration of motor may occur.

Note:

1. The firmware versions of v1.06x1 sub65 and v1.0635 sub55 and above support third-party motors.
2. Refer to Section 11.3.1 for details.

**11.2.3.2 Supported communication format for the motors**

- The A3 firmware versions of v1.06x1 sub65 and v1.0635 sub55 and above support both third-party rotary and linear motors.
- The A3 firmware version of v1.11x5 sub92 and above support Nikon’s communication format.
- Due to the control IC shortage, the following functions marked with an asterisk (\*) are temporarily affected for all A3 servo drives manufactured in week 23 of year 2022 or later. Contact Delta FAEs or sales representatives if needed.

Communication format	A3-L	A3-F	A3-M	A3-E	Note
Delta	V	V	V	V	-
Mitutoyo	V	V	V	V*	Brand: Mitutoyo
BiSS C	X	V*	V*	V*	Brand: Renishaw, Beckhoff
Endat2.2	X	V*	V*	V*	Brand: HEIDENHAIN
Fagor	V	V	V	V*	Brand: Fagor
Tamagawa	V	V	V	V*	Brand: Tamagawa
Nikon	V	V	V	V*	Brand: Nikon

**11.2.3.3 Pin assignment of communication type motors**

The CN2 connector pin assignment for communication type motors is as follows.

Pin No.	Delta	BiSS C	Endat2.2	Mitutoyo	Fagor	Tamagawa	Nikon
1	+5V	+5V	+5V	+5V	+5V	+5V	Vcc
2	GND	GND	GND	GND	GND	GND	GND
3	-	MA+	Clock+	-	-	-	-
4	-	MA-	Clock-	-	-	-	-
5	T+	SL+	Data+	REQ / SQ	REQ / SQ	SD	SD
6	T-	SL-	Data-	*REQ / *SQ	*REQ / *SQ	SD-	SD-

Note: make sure the signal wires are twisted in pair and shielded.

### 11.3 Complete the settings for linear motors and third-party motors with ASDA-Soft

Connect the motor to the servo drive first and then start ASDA-Soft. When the New Device window appears, select the correct Motor Type: “Linear” is for linear motors and “Rotary” is for rotary motors. If you do not select the correct motor type, a unit error occurs during parameter setting.

Note: the unit setting for the rotary motor and linear motor can be different for the same parameter.

Refer to Chapter 8 for more information.

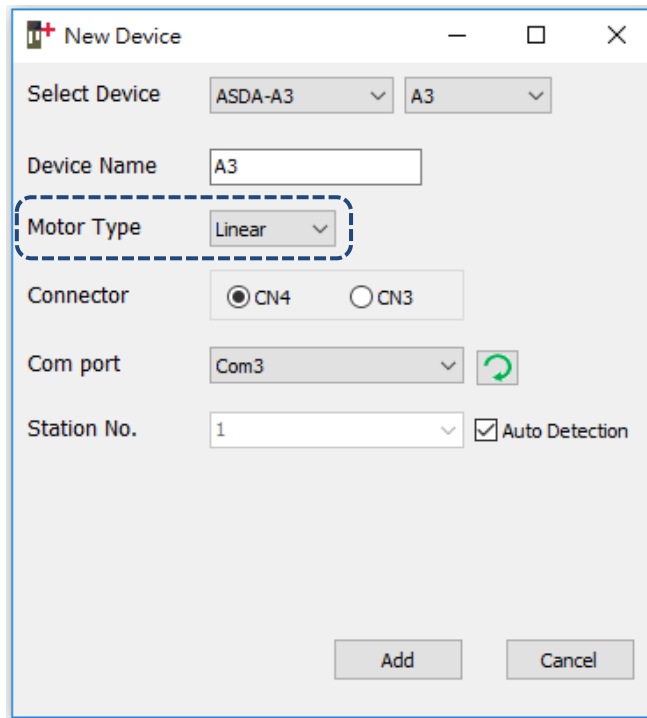

#### Comparison of rotary motor and linear motor:

	Rotary motor	Linear motor
Speed unit	rpm	mm/s, μm/s
Acceleration unit	0→3000 rpm/ms	0→5 ( $\frac{m}{s}$ )/ms
Load ratio (P1.037)	Load inertia ratio	Total weight (kg)
Feedback type	Encoder	Linear scale, magnetic scale
Z pulse	One per revolution	Unlimited

# 11

### 11.3.1 Motor parameter identification

If you are using the ASDA-A3 servo drive for motor parameter identification of Z-axis motors, the identification may fail due to gravity. It is suggested that you place the motor on a flat surface before starting the identification.

After starting ASDA-Soft, check the current control mode of the servo drive. If the servo drive is in communication mode, first set it to a general mode (i.e. Position, Speed, or Torque mode) and then cycle the power before executing the Motor Parameter Identification Wizard (see the path in the following figure). If you do not execute the motor parameter identification, an alarm may be triggered due to the parameter setting error, or the motor may be burnt due to the motor current setting error. When you replace the motor with a different motor model, execute the motor parameter identification again.

During the identification, the motor moves by 1 pole pair distance or 1 pole pitch. It is suggested that you execute the motor parameter identification before installing the mechanical parts; otherwise there is a risk of collision when the mechanical parts are moving.

Note: Delta C3 pulse type motors require the motor parameter identification.

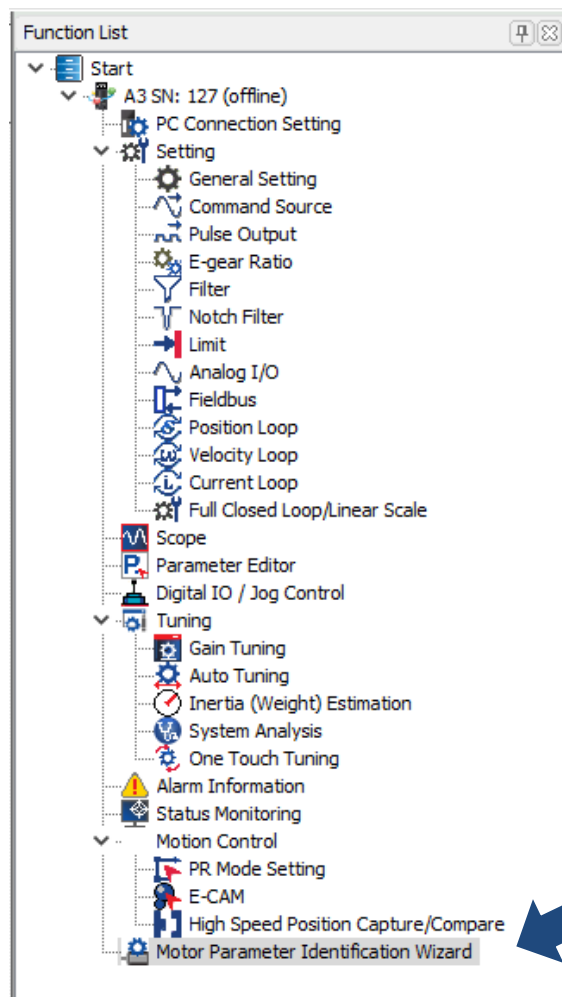

### 11.3.1.1 Motor parameter identification for linear motors

As shown in the following figure, there are four steps in the motor parameter identification procedure for the linear motors, "Select Motor Type", "Set Motor Parameters", "Set Feedback Signal", and "Start Motor Identification". You can complete the setting by following the four steps. The details are as follows.

Step 1: Select Motor Type

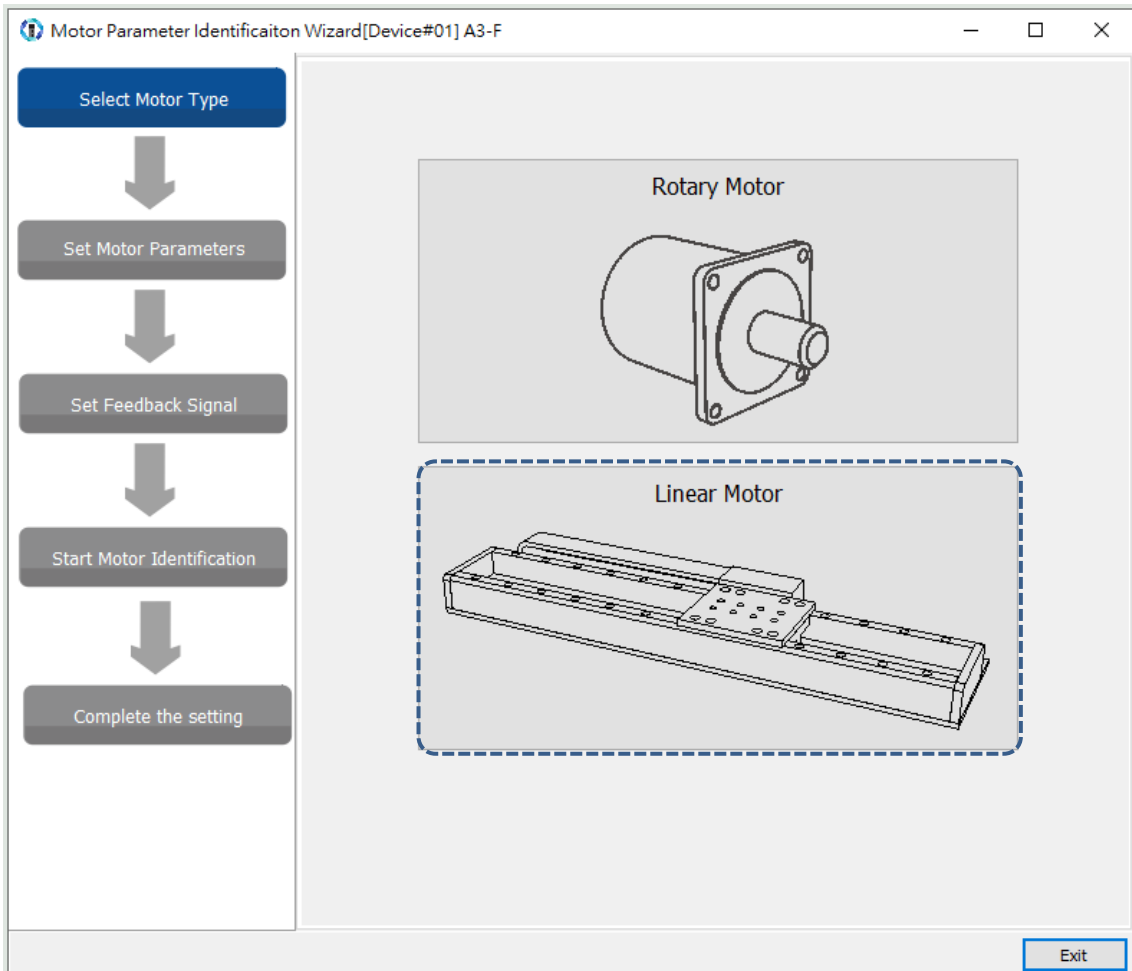

Start the Motor Parameter Identification Wizard and select "Linear Motor".



Step 2: Set Motor Parameters

11

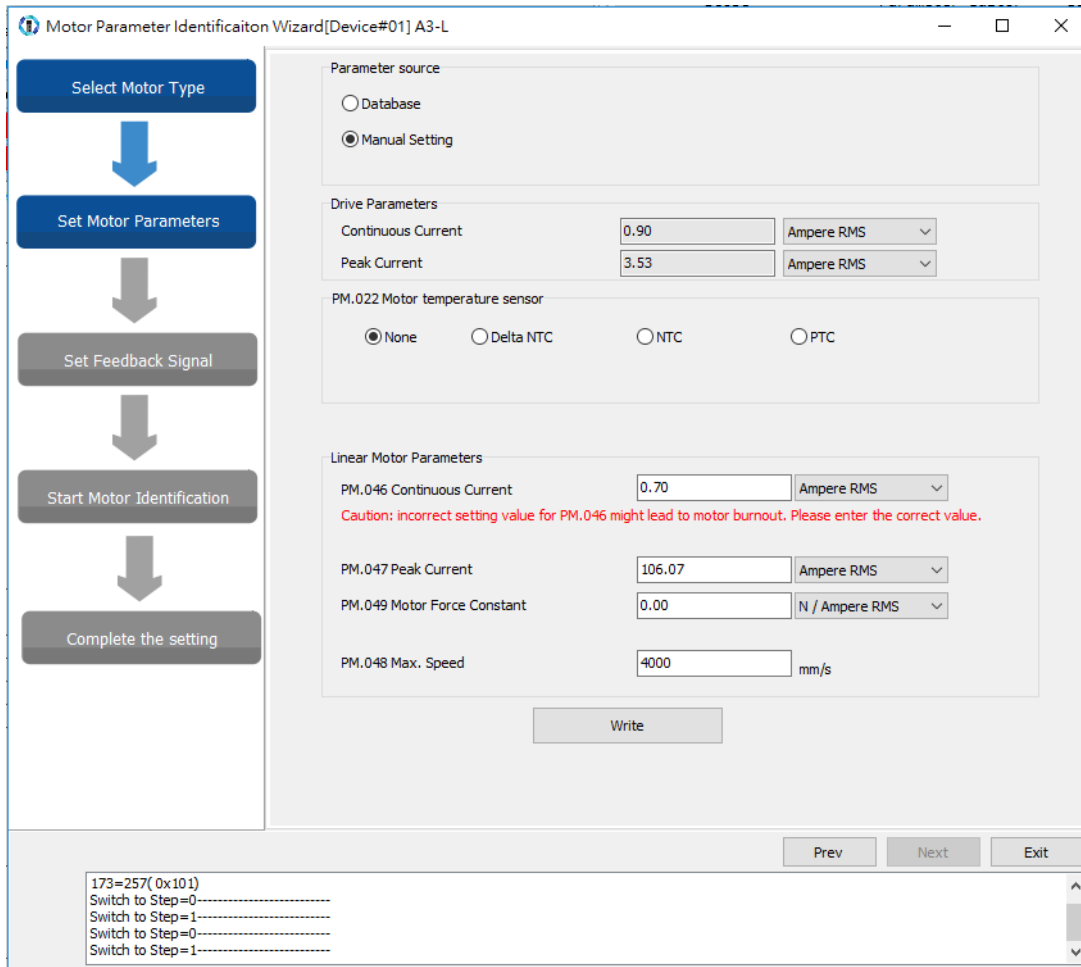

**Parameter source:** there are two options. For “Database”, you only need to confirm the Delta linear motor model and the software automatically fills in the motor specifications according to the content in the database. For “Manual Setting”, input all linear motor specifications manually.

**PM.022 Motor temperature sensor:** if the third-party motor is equipped with a temperature sensor, select the type of the temperature sensor and then set PM.024 (Motor temperature sensor resistance).

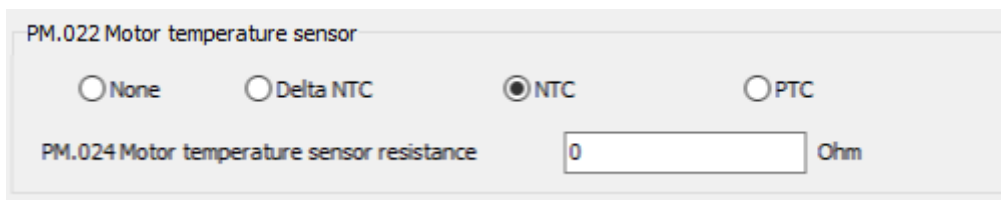

**Linear Motor Parameters:** correctly set the motor current parameters (PM.046 and PM.047), or the motor may be burnt. Be sure to double check the parameter settings and whether the unit is Ampere RMS or Ampere Peak.

When the settings are complete, click **Write** and then click **Next**.

Note: the grayed-out fields are read-only and cannot be edited.

Step 3: Set Feedback Signal

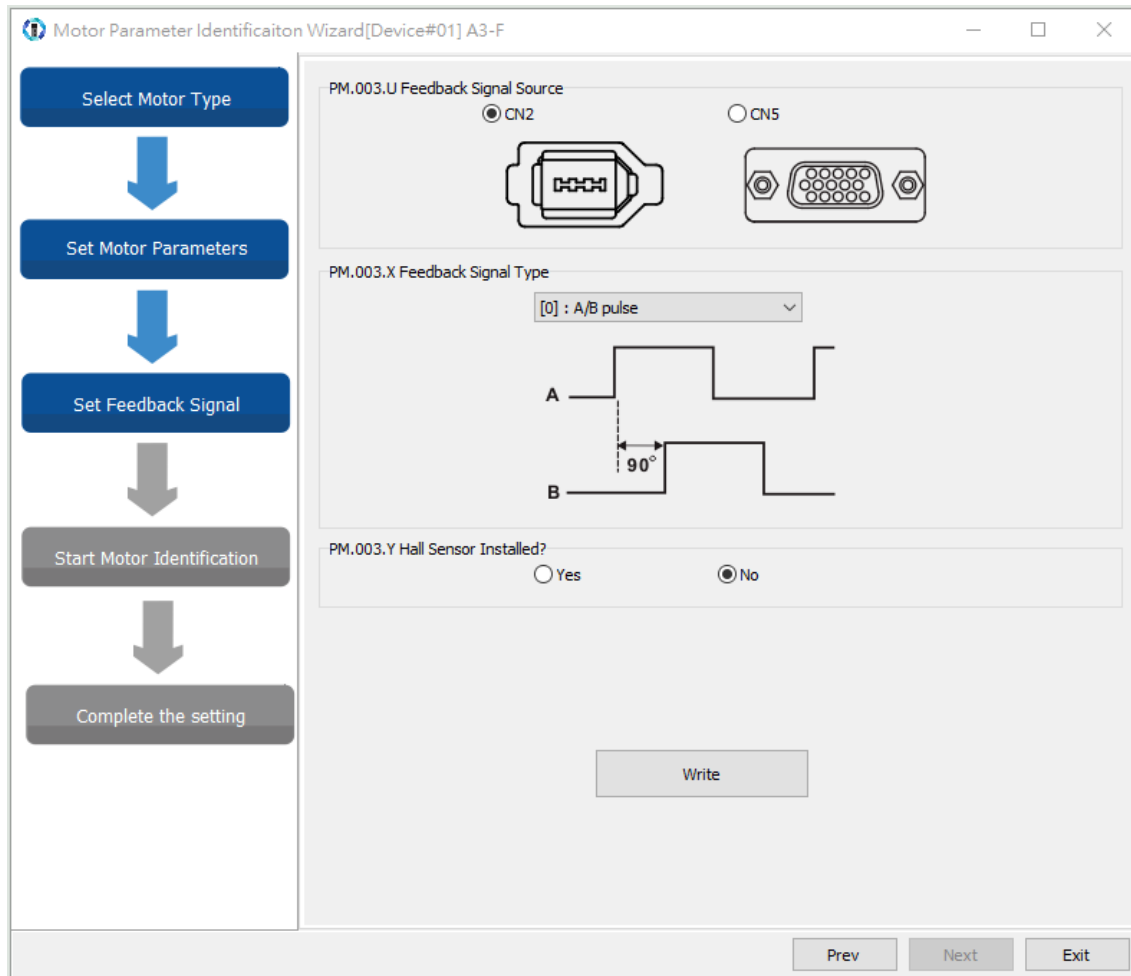

11

**PM.003.U Feedback Signal Source:** ASDA-A3 supports pulse type (square wave), sine wave type, and some of the third-party communication type linear encoders. The CN5 position feedback signal connector can directly receive the pulse signals from the linear encoder. If you select CN2 encoder signal connector for receiving pulses or sine waves, it has to work with the position signal converter box. Select “CN2” for the communication type linear encoders. If the hardware connection does not match the parameter settings, AL011 is triggered.

**PM.003.X Feedback Signal Type:** when the signal source is CN2, after the servo drive detects the position signal converter box, select A/B pulse or sin/cos type feedback signal from the drop-down menu. When the signals are transmitted through communication, setting this field is not required. When the signal source is CN5, this connector only receives pulse signals and the field option is unavailable.

**PM.003.Y Hall Sensor Installed:** check if the Hall sensor is installed.

When the settings are complete, click **Write** and then click **Next**.

The encoder / linear scale settings include pulse type, sine wave type, and communication type. Refer to the following for more details.

# 11

## Encoder / Linear Scale Setting (pulse type)

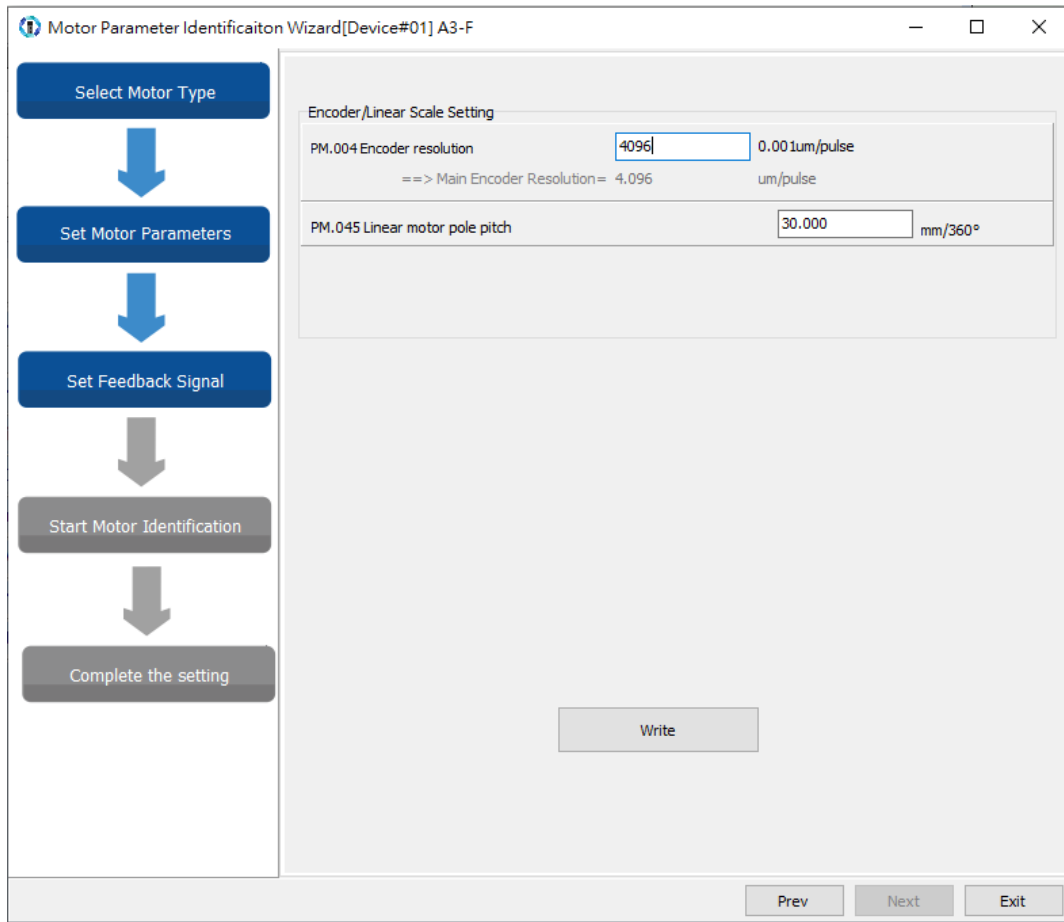

**PM.004 Main encoder resolution:** input the linear scale resolution after frequency quadrupling (unit: 0.001  $\mu\text{m}/\text{pulse}$ ). For example, if the linear scale resolution is 1  $\mu\text{m}/\text{pulse}$ , then PM.004 = 1000.

**PM.045 Linear motor pole pitch:** you can find this value in the linear motor catalog, or you can select a linear motor model from the database and the value is automatically filled in; if you are using a third-party linear motor or the linear motor is not yet created in Delta's database, you must input the value manually. If the set value is incorrect, AL051 is triggered.

When the settings are complete, click **Write** and then click **Next**.

Note: the grayed-out field is read-only and cannot be edited.

■ Encoder / Linear Scale Setting (sine wave type)

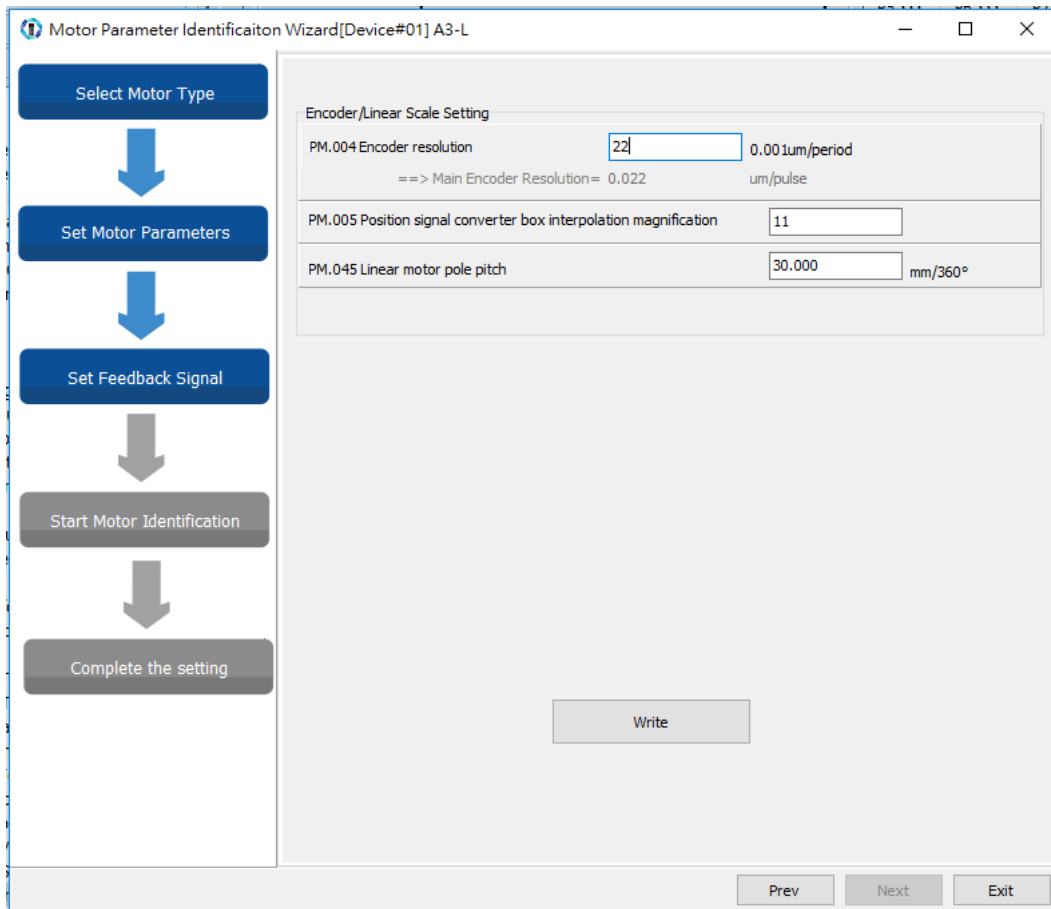

11

**PM.004 Main encoder resolution:** input the corresponding distance for the motor single-phase sine wave (unit: 0.001  $\mu\text{m}/\text{period}$ ).

**PM.005 Position signal converter box interpolation magnification:** it is suggested that you set it to the default value of 11. After the interpolation, the resolution is  $\text{PM.004} \times 0.001 / 2^N$ , and  $N = \text{PM.005}$ .

**PM.045 Linear motor pole pitch:** you can find this value in the linear motor catalog. If the set value is incorrect, AL051 is triggered.

When the settings are complete, click **Write** and then click **Next**.

Note: the grayed-out field is read-only and cannot be edited.

11

■ Encoder / Linear Scale Setting (communication type)

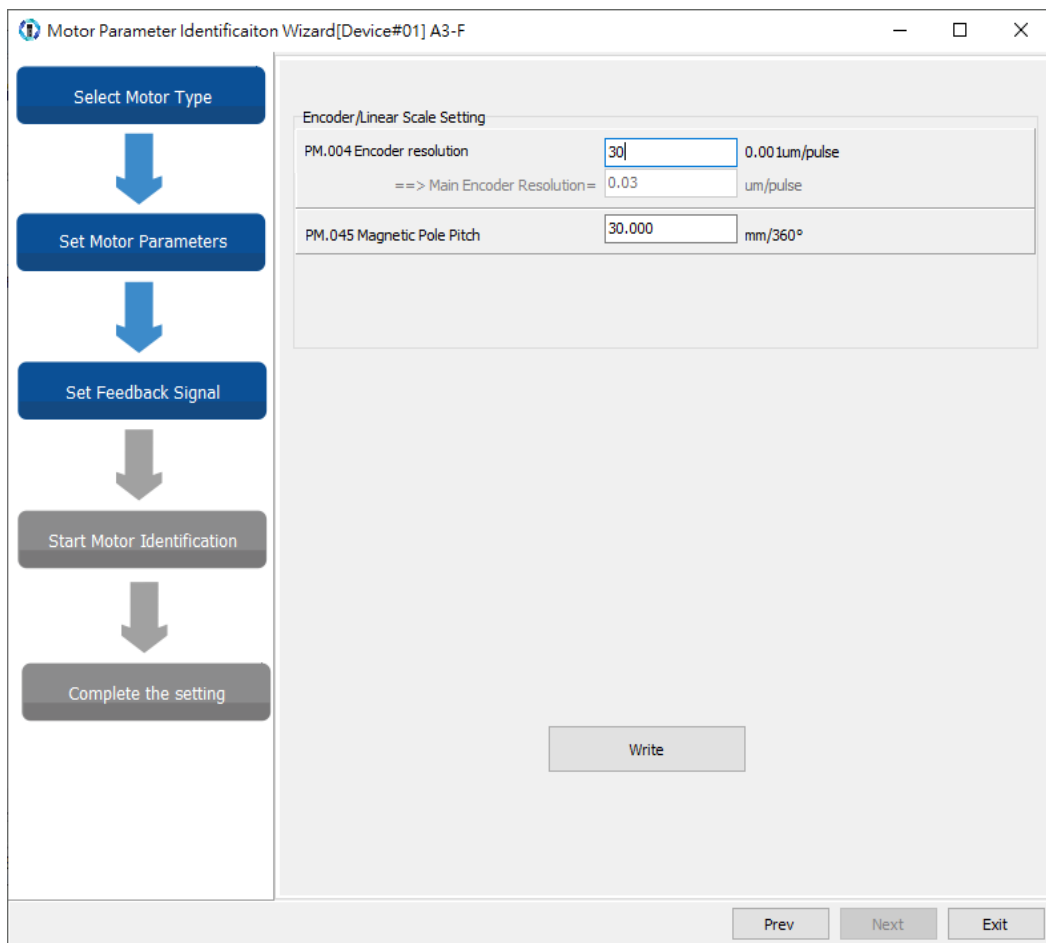

Input the values of PM.004 (Main encoder resolution) and PM.045 (Linear motor pole pitch).  
When the settings are complete, click **Write** and then click **Next**.

Note: the grayed-out field is read-only and cannot be edited.

Step 4: Start Motor Identification

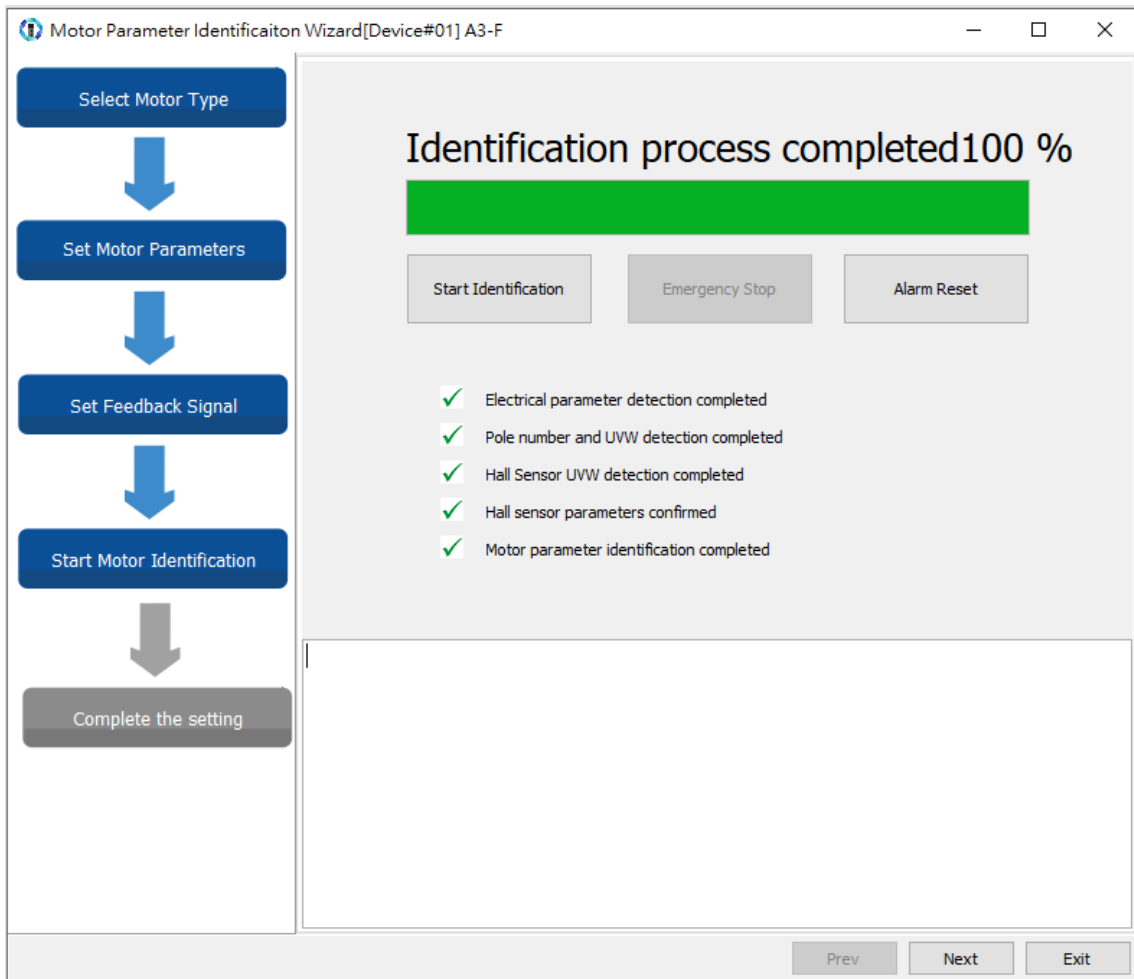

11

Manually move the linear motor to the center of the platform or move it back and forth for one pole pitch. To avoid damage to the machine and personnel injury, before executing the motor identification, make sure there is no person nearby because the platform moves slightly when the motor identification process is executed.

If an alarm occurs during the identification process, refer to Chapter 14 Troubleshooting to clear the alarm. The software continues with the identification process only when the alarm is cleared. Cycle power to the servo drive after the identification process is complete. Without cycling the power, you cannot switch the servo to the Servo On state.

# 11

### 11.3.1.2 Motor parameter identification for rotary motors

As shown in the following figure, there are four steps in the motor parameter identification procedure for the rotary motors, “Select Motor Type”, “Set Motor Parameters”, “Set Feedback Signal”, and “Start Motor Identification”. You can complete the setting by following the four steps. The details are as follows.

#### Step 1: Select Motor Type

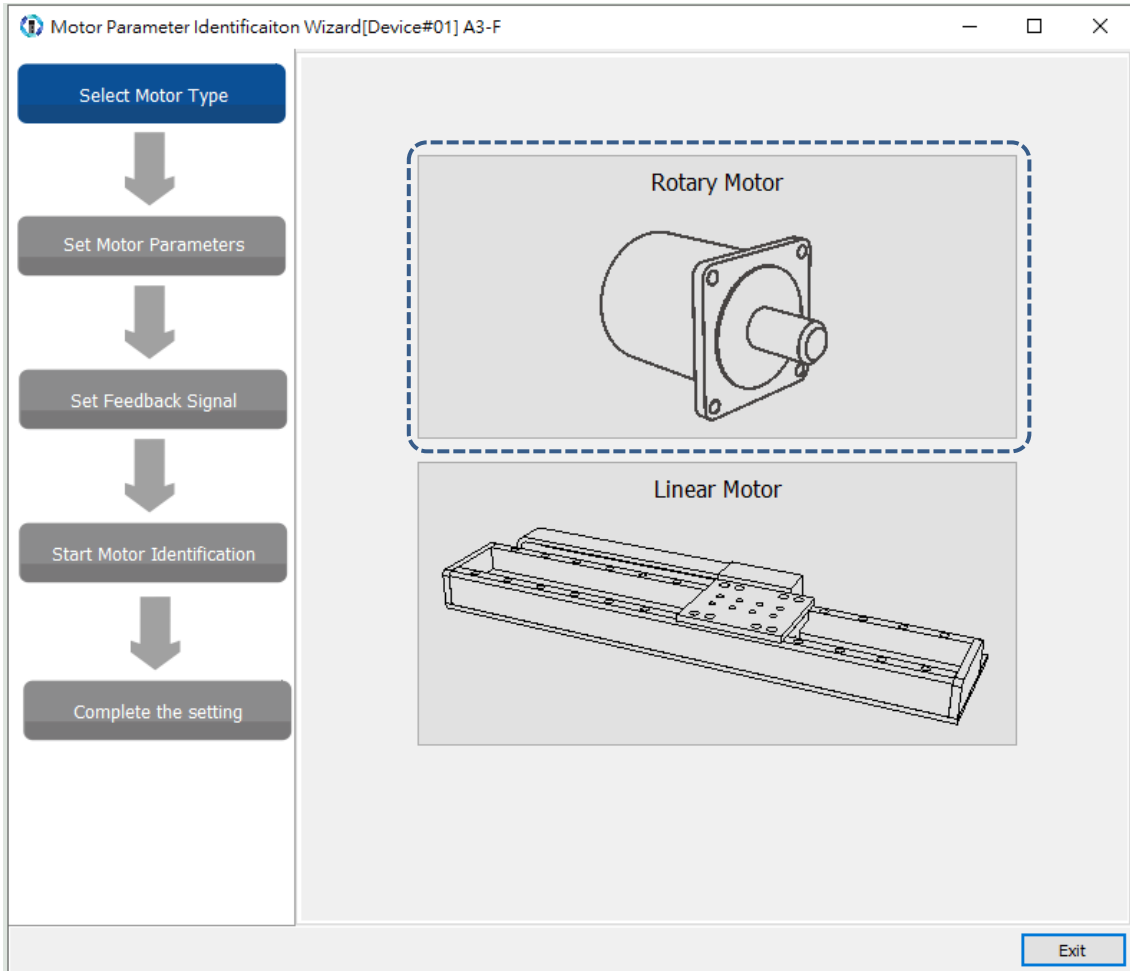

Start the Motor Parameter Identification Wizard and select “Rotary Motor”.

Step 2: Set Motor Parameters

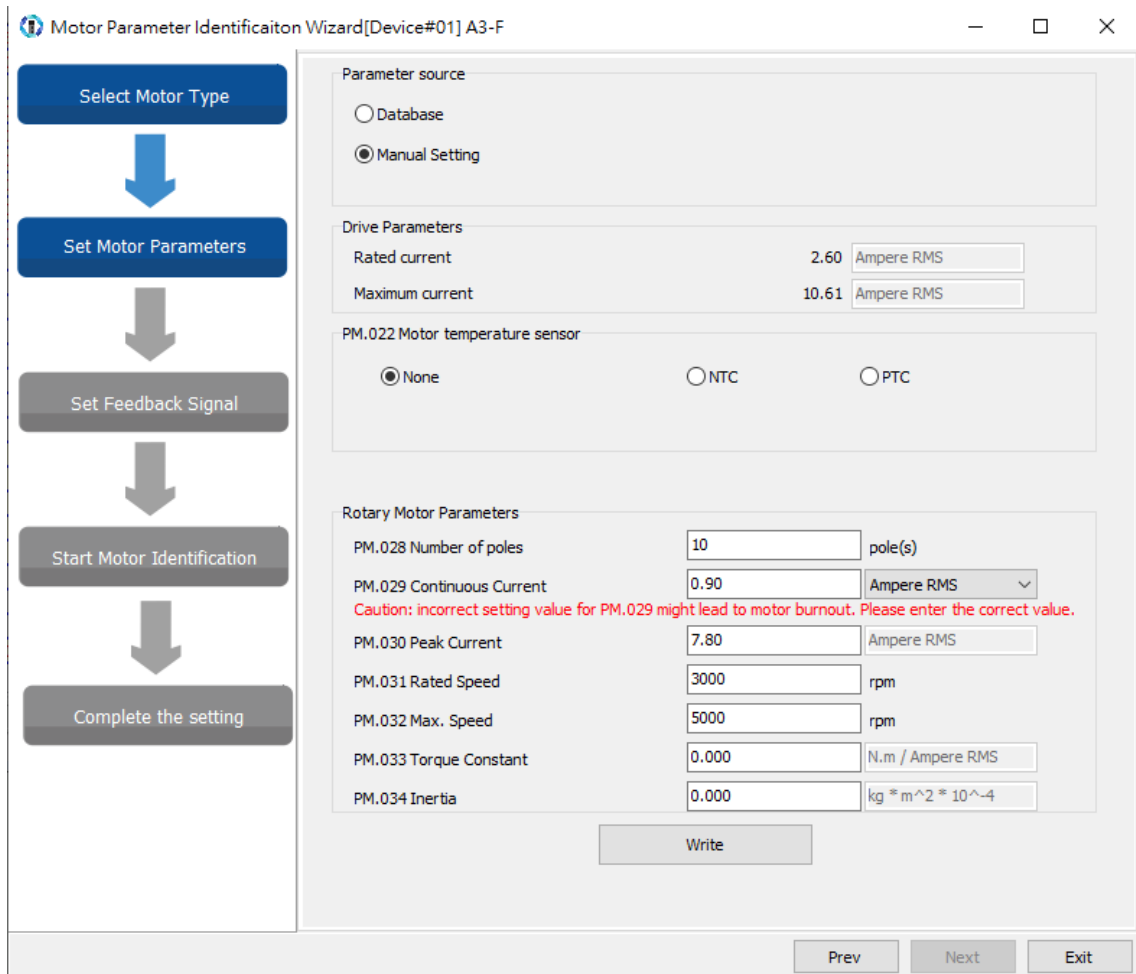

11

**Parameter source:** Delta C3 pulse type rotary motors and third-party communication type motors only support “Manual Setting”. Delta communication type motors do not require the identification.

**PM.022 Motor temperature sensor:** if the third-party motor is equipped with a temperature sensor, select the type of the temperature sensor and then set PM.024 (Motor temperature sensor resistance).

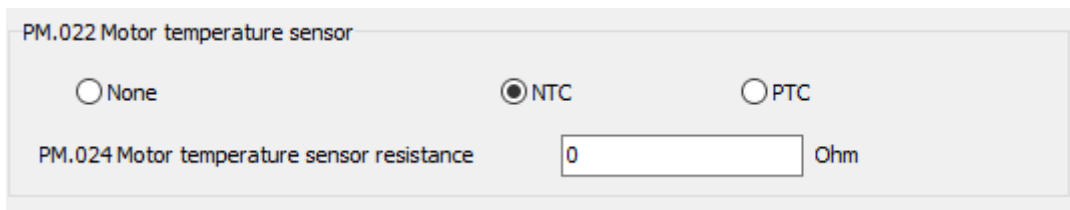

**Rotary Motor Parameters:** input all motor specifications manually. Correctly set the motor current parameters (PM.029 and PM.030), or the motor may be burnt. Be sure to double check the parameter settings and whether the unit is Ampere RMS or Ampere Peak.

When the settings are complete, click **Write** and then click **Next**.

Note: the grayed-out fields are read-only and cannot be edited.



Step 3: Set Feedback Signal

11

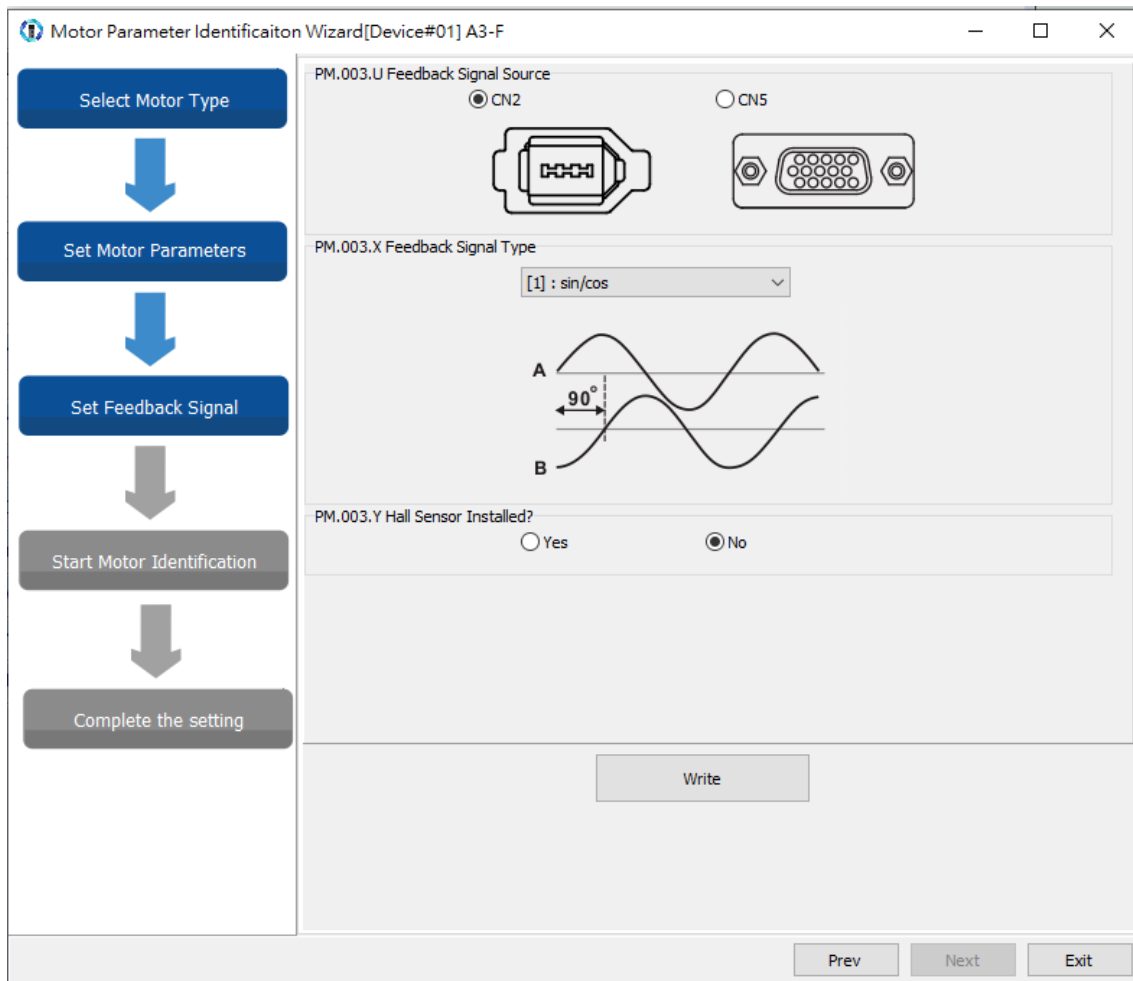

**PM.003.U Feedback Signal Source:** ASDA-A3 supports pulse type (square wave), sine wave type, and some of the third-party communication type encoders. The CN5 position feedback signal connector can directly receive the pulse signals from the encoder. If you select CN2 encoder signal connector for receiving pulses or sine waves, it has to work with the position signal converter box. Select “CN2” for the communication type encoders. If the hardware connection does not match the parameter settings, AL011 is triggered.

**PM.003.X Feedback Signal Type:** when the signal source is CN2, after the servo drive detects the position signal converter box, select A/B pulse or sin/cos type feedback signal from the drop-down menu. When the signals are transmitted through communication, setting this field is not required. When the signal source is CN5, this connector only receives pulse signals and the field option is unavailable.

**PM.003.Y Hall Sensor Installed:** check if the Hall sensor is installed.

When the settings are complete, click **Write** and then click **Next**.

Note: the grayed-out field is read-only and cannot be edited.

The encoder / linear scale settings include pulse type, sine wave type, and communication type. Refer to the following for more details.

■ Encoder / Linear Scale Setting (pulse type)

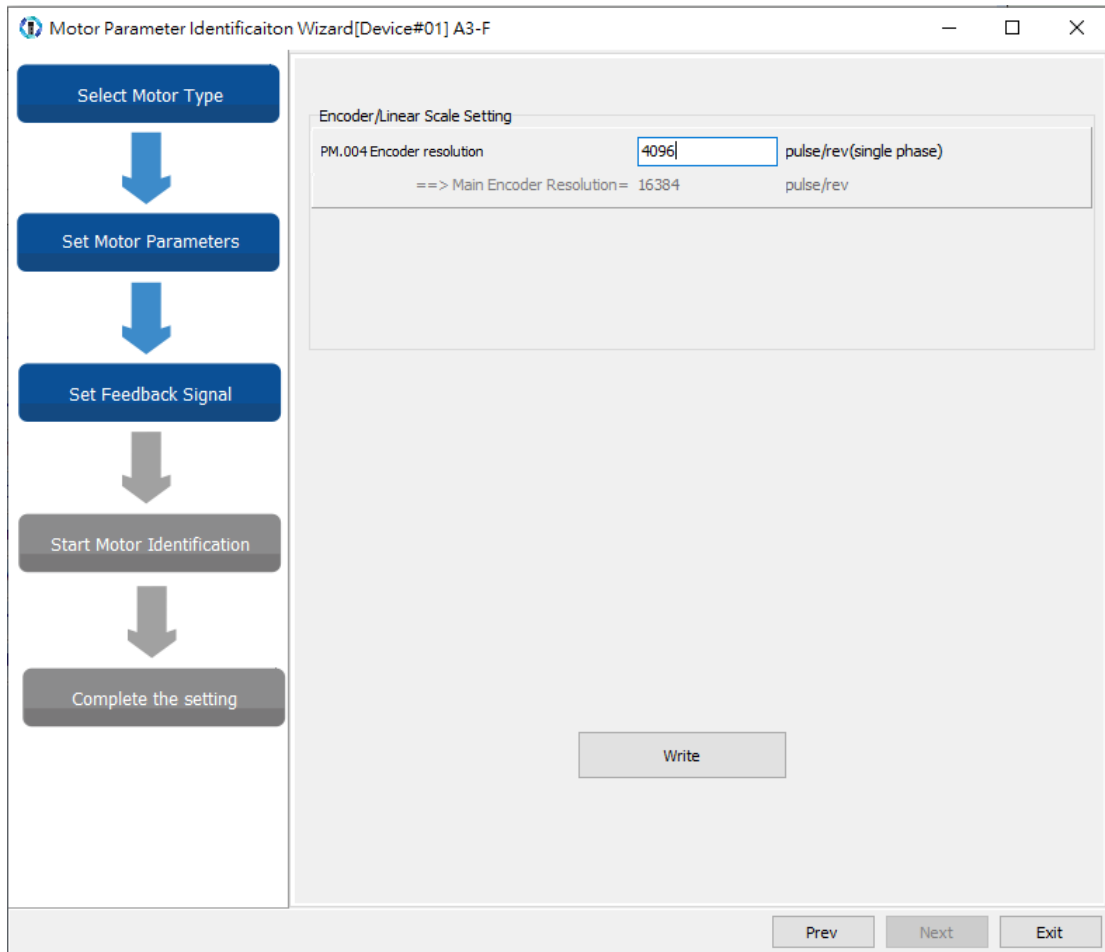

11

**PM.004 Main encoder resolution:** input the single-phase pulse number of one revolution (unit: pulse/rev).

When the settings are complete, click **Write** and then click **Next**.

Encoder / Linear Scale Setting (sine wave type)

11

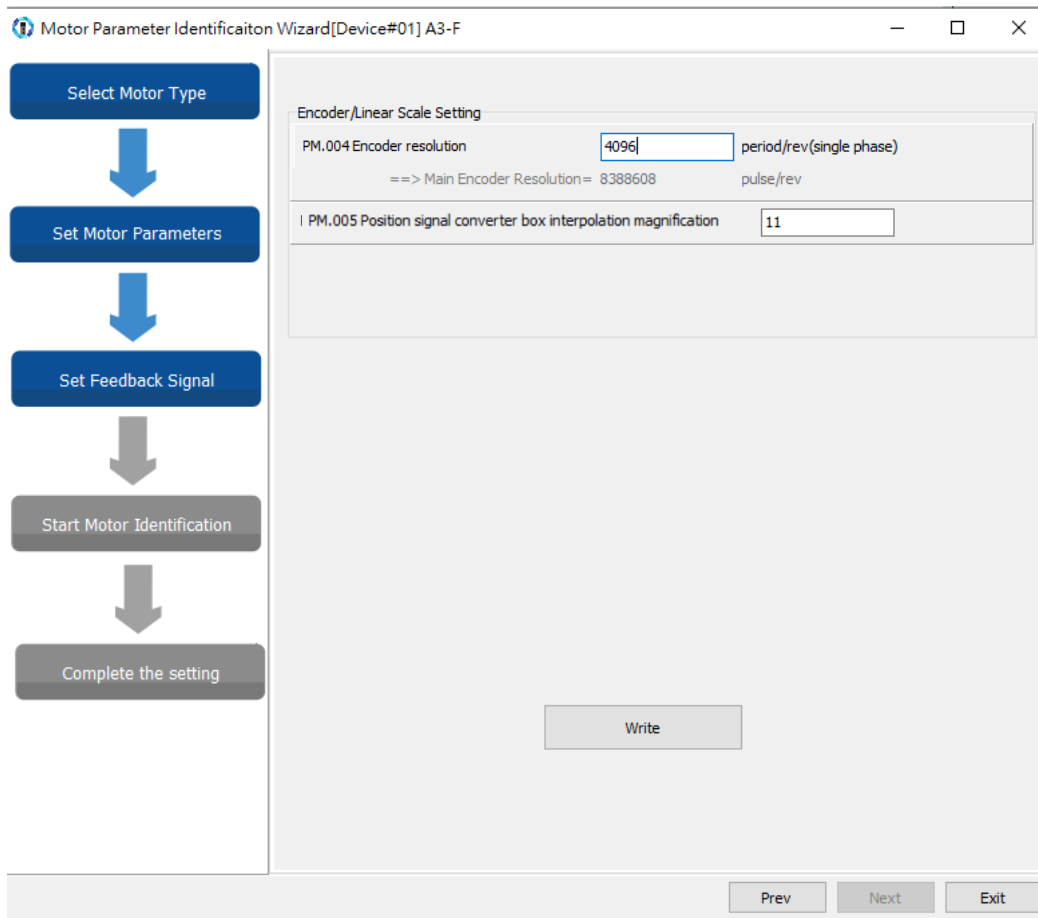

**PM.004 Main encoder resolution:** input the single-phase sine wave pulse number of one revolution (unit: period/rev).

**PM.005 Position signal converter box interpolation magnification:** it is suggested that you set it to the default value of 11. After the interpolation, the resolution is  $PM.004 \times 2^N$  pulse/rev, and  $N = PM.005$ .

When the settings are complete, click **Write** and then click **Next**.

## Encoder / Linear Scale Setting (communication type)

Motor Parameter Identification Wizard[Device#01] A3-F

Select Motor Type

Set Motor Parameters

Set Feedback Signal

Start Motor Identification

Complete the setting

Encoder/Linear Scale Setting

PM.004 Encoder resolution  bits

==> Main Encoder Resolution= 16777216 pulse/rev

Write

Prev Next Exit

Write P2.008=40  
Write PM.000=0  
Write OK PM.009=4  
Switch to Step=2-----  
Switch to Step=3-----

11

Input the value of PM.004 Main encoder resolution (unit: bits).

When the settings are complete, click **Write** and then click **Next**.

Step 4: Start Motor Identification

11

Motor Parameter Identificaiton Wizard[Device#01] A3-F

Select Motor Type

Set Motor Parameters

Set Feedback Signal

Start Motor Identification

Complete the setting

Identification process completed 100 %

Start Identification Emergency Stop Alarm Reset

- ✓ Electrical parameter detection completed
- ✓ Pole number and UVW detection completed
- ✓ Motor parameter identification completed

Prev Next Exit

If an alarm occurs during the identification process, refer to Chapter 14 Troubleshooting to clear the alarm. The software continues with the identification process only when the alarm is cleared. Cycle power to the servo drive after the identification process is complete. Without cycling the power, you cannot switch the servo to the Servo On state.

### 11.3.2 Linear motor direction setting

After completing the setting for the Motor Parameter Identification Wizard, set the movement direction for the linear motor. Incorrect direction setting results in incorrect direction of movement, causing the limit switch invalid and increasing the risk of collision. Use the JOG mode to set the linear motor direction with the jog speed in units of 0.01 mm/s. When executing jog control, check if the jog speed is set too slow or too fast. If it is too slow, you may think that the motor is not actuated; if it is too fast, it may cause the motor to crash.

Flowchart of linear motor direction setting:

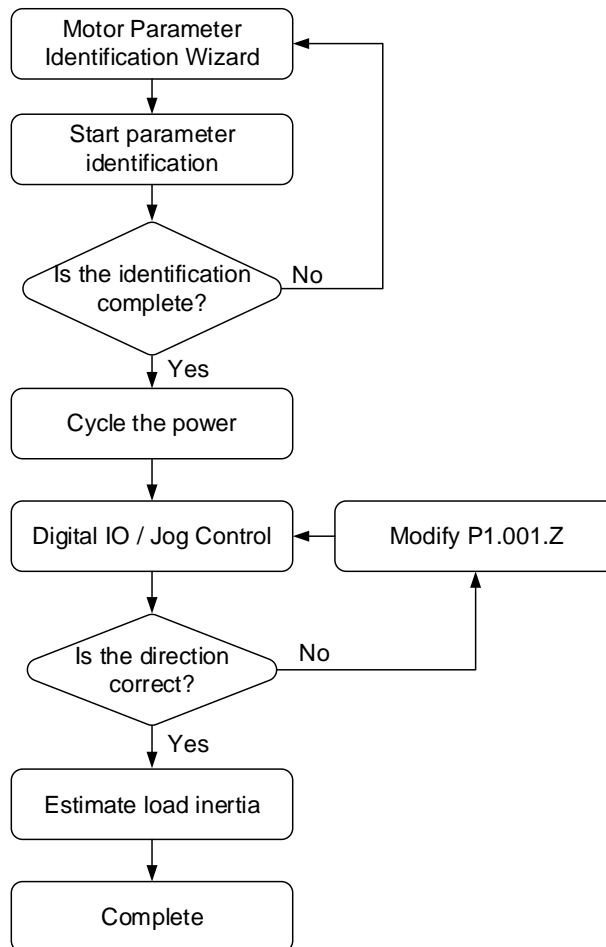

## 11

## 11.4 Linear encoder

The linear encoder generally refers to a linear scale or a magnetic scale, which is mainly used to monitor the linear motor position and return the position data to the servo drive for the purpose of servo control. Set PM.003 for the linear scale. If AL011 is triggered when the linear motor is in operation, check if PM.003.U is set correctly.

The linear encoder includes sine wave type and pulse type. Currently, the CN5\*2 of ASDA-A3 only supports pulse type encoders, and sine wave type encoders must be used with a position signal converter box connected to CN2.

Note:

1. For detailed parameter description, refer to Chapter 8 Parameters.
2. The CN5 single-phase maximum input frequency is 4 Mpps.

### 11.5 Hall sensor

The magnetic pole sensor, also known as the Hall sensor, can be used to detect the motor pole. The servo drive must know the position of the motor magnetic field to efficiently actuate the motor and move the motor in the right direction. As shown in the following figure, the Hall sensor generally sends three-phase signals. The Hall sensor divides the motor magnetic field from 0° to 360° by the three-phase signals into six blocks (1, 0, 1), (1, 0, 0), (1, 1, 0), (0, 1, 0), (0,1,1), and (0,0,1), so that the servo drive can know the current position of the motor magnetic field. Before using the linear motor, check if it is equipped with a Hall sensor (or determine whether to use the Hall sensor according to the Motor Parameter Identification Wizard). If a Hall sensor is installed, set PM.003.Y to 1. If you are not using the installed Hall sensor or the linear motor is not equipped with a Hall sensor, set PM.003.Y to 0. When you are not using a Hall sensor, install a spring or balancing unit for the Z-axis mechanical part. If the magnetic pole is detected in the condition without a sensor, the motor slightly vibrates during the detection after the servo is switched to the Servo On state for the first time after power on. Currently, ASDA-A3 only supports Hall sensor of non-differential signals. Refer to Chapter 3 for the wiring of CN5 connector or Section 11.6 Position signal converter box.

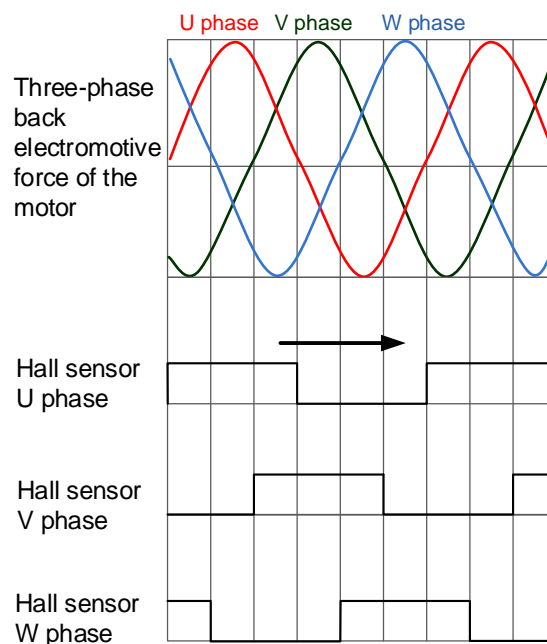



### 11.5.1 Installing the Hall sensor

Follow these instructions when installing the Hall sensor.

11

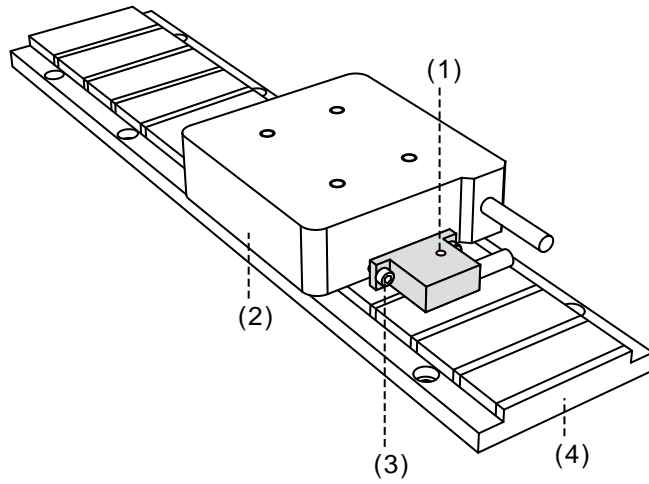

(1) The screw hole side up; (2) Mover; (3) M3 screw; (4) Stator

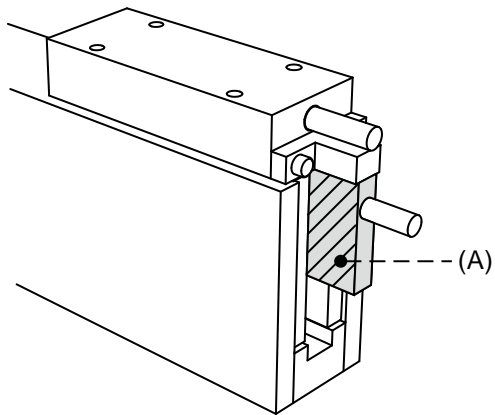
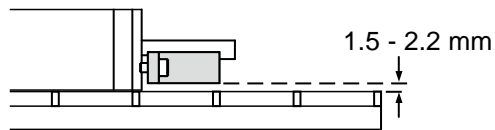

(A) Hall sensor

### 11.5.2 Checking the Hall sensor phase sequence

To check the phase sequence of the Hall sensor, set P0.017 to the monitoring variable -177 and observe the change of phase sequence with P0.009. The bits of this monitoring variable are (bit 3, bit 2, bit 1) = (W, V, U). The following figure shows the waveform monitored by the scope when you manually move the linear motor. You can see the phase sequence in the cycle of (1, 0, 1), (1, 0, 0), (1, 1, 0), (0, 1, 0), (0, 1, 1), and (0, 0, 1). When the motor reverses, the phase sequence is also reversed. Incorrect phase sequence may cause the motor to go in the wrong direction or even be out of control.

Note: for the monitoring variable -177, Bit 1 represents U phase, Bit 2 represents V phase, and Bit 3 represents W phase.

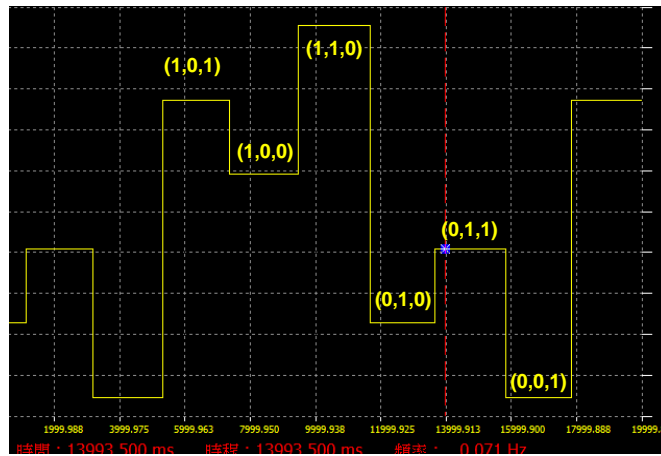

## 11

## 11.6 Position signal converter box

The position signal converter box is developed by Delta to convert the feedback signals of the third-party encoders. With this product, the feedback signals of pulses or sine waves can be converted into Delta's communication format and returned to the servo drive through CN2 without an external power supply. In addition, the position signal converter box can use the interpolation sine wave signals to increase the resolution and avoid the frequency limit.

### 11.6.1 Specifications of position signal converter box

Model name	ASD-IF-EN0A20
Power supply requirement	+5.0V $\pm$ 5%
Current consumption	250 mA Typ. 500 mA Max.
Input signal frequency	Analog signal: 500 kHz Max. Pulse signal: 2 MHz Max.
Analog input signal (Sin, Cos, Ref)	Differential input amplitude: 0.4 to 1.2Vp-p Input signal active level: 1.5 to 2.7V
Pulse input signal	+5V
Hall sensor input signal	+3.3V
Output signal	Position data / Hall sensor data / warning
Output type	Serial data transmission
Weight	Approx. 70 g
Operating temperature	0°C to 55°C (32°F to 131°F)
Storage temperature	-20°C to +65°C (-4°F to +149°F)

### 11.6.2 Interface of position signal converter box

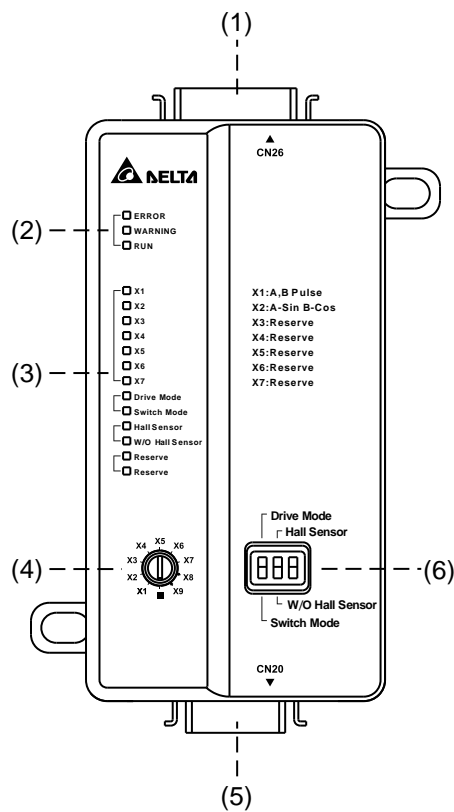

11

No.	Item	Description	
(1)	Connector for signal source CN26	26-pin connector.	
(2)	Status indicator	ERROR*	Alarm indicator.
		WARNING*	Warning indicator.
		RUN	Normal operation indicator.
(3)	Function indicator LED	Displays according to the status of the signal switch knob (4) and function switch (6).	
(4)	Signal switch knob	X1	Square wave digital signal as the source.
		X2	Sine wave analog signal as the source.
		X3 - X9	Function not supported.
(5)	Connector for connecting to the servo drive CN20	20-pin connector.	
(6)	Function switch	Drive Mode	The converter box status is controlled by the commands from the servo drive; meanwhile, the signal switch knob (4) and the function switch (6) are invalid.
		Switch Mode	The converter box status is controlled by the signal switch knob (4) and the function switch (6) on the converter box; meanwhile, the commands from the servo drive are invalid.
		Hall Sensor	With a Hall sensor installed.
		W/O Hall Sensor	Without a Hall sensor installed.

Note: the indicators of ERROR and WARNING are irrelevant to the servo alarms; they are for the signal converter box only.

### 11.6.3 Pin assignment of position signal converter box

#### CN26 pin assignment

Pin	Assignment	Description	Pin	Assignment	Description
1	QEA_IN+	A phase pulse (+) input	14	AGND	Analog signal ground (motor temperature)
2	QEA_IN-	A phase pulse (-) input	15	NC	For internal use only. DO NOT connect this pin.
3	QEB_IN+	B phase pulse (+) input	16	HALL_W	W phase Hall sensor signal input
4	QEB_IN-	B phase pulse (-) input	17	HALL_V	V phase Hall sensor signal input
5	QEZ_IN+	Z phase pulse (+) input	18	HALL_U	U phase Hall sensor signal input
6	QEZ_IN-	Z phase pulse (-) input	19	NC	For internal use only. DO NOT connect this pin.
7	QES_IN	Single Z phase pulse input	20	NC	For internal use only. DO NOT connect this pin.
8	A+_IN	A phase sine wave (+) input	21	NC	For internal use only. DO NOT connect this pin.
9	A-_IN	A phase sine wave (-) input	22	NC	For internal use only. DO NOT connect this pin.
10	B+_IN	B phase sine wave (+) input	23	GND	Digital signal ground (Hall sensor power ground)
11	B-_IN	B phase sine wave (-) input	24	GND	Digital signal ground (Linear scale power ground)
12	R+_IN	Z phase sine wave (+) input	25	5VD	+5V power supply
13	R-_IN	Z phase sine wave (-) input	26	5VD	+5V power supply

#### CN20 pin assignment

Pin	Assignment	Description	Pin	Assignment	Description
1	NC	For internal use only. DO NOT connect this pin.	11	NC	For internal use only. DO NOT connect this pin.
2	NC	For internal use only. DO NOT connect this pin.	12	NC	For internal use only. DO NOT connect this pin.
3	NC	For internal use only. DO NOT connect this pin.	13	GND	Power ground
4	Drive_T-	Serial communication signal transmission (-)	14	5VD	+5V power supply
5	Drive_T+	Serial communication signal transmission (+)	15	GND	Power ground
6	NC	For internal use only. DO NOT connect this pin.	16	5VD	+5V power supply
7	NC	For internal use only. DO NOT connect this pin.	17	NC	For internal use only. DO NOT connect this pin.
8	NC	For internal use only. DO NOT connect this pin.	18	NC	For internal use only. DO NOT connect this pin.
9	NC	For internal use only. DO NOT connect this pin.	19	NC	For internal use only. DO NOT connect this pin.
10	NC	For internal use only. DO NOT connect this pin.	20	NC	For internal use only. DO NOT connect this pin.

Note: NC represents “No connection”, which is for internal use only. Do not connect to NC, or it may damage the servo drive.

## 11.7 Linear motor parameter setting

Some parameter settings are different for linear motors and rotary motors. The following sections describe the definitions and precautions for linear motor parameter settings. Before setting the parameters, refer to Chapter 8 Parameters for more information. Some parameter setting values and units for the linear motor are different from those for the rotary motor, which are further explained in the following sections.

### 11.7.1 Total weight (mover + load)

The total weight estimation methods for the linear motor and the rotary motor are similar, but the setting value for the total weight of the linear motor (P1.037) is in units of kg. During the estimation, it is advisable to set the speed (P4.005) to 20000 (unit: 0.01 mm/s) or above and set the time (P5.020) to 1.5 seconds or less for the linear motor to accelerate from 0 to 5 m/s or to decelerate from 5 m/s to 0.

### 11.7.2 E-Gear ratio

It is recommended that you set the E-Gear ratio for the linear motor to  $\frac{P1.044}{P1.045} = \frac{1}{1}$ .

If the E-Gear ratio is 1, when the command issues 1 PUU, the linear scale feedback is 1 pulse; if the E-Gear ratio is 2, when the command issues 1 PUU, the linear scale feedback is 2 pulses. Incorrect E-Gear ratio setting may result in an error between the command and the actual movement distance.

### 11.7.3 Limit setting

The limit setting function is to protect the motor from exceeding the allowable range. Connect the physical signal switch to the DI for protecting the machine and avoiding collision.

As shown in the following figure, the X and Y of the DI are user-defined. The DIX in this figure is defined as the positive limit (PL) and the DIY is defined as the negative limit (NL), which are defined as Positive inhibit limit (0x23) and Negative inhibit limit (0x22) by the digital inputs of Delta servo drives. When the forward or reverse direction changes, change the positive and negative limit settings as well; otherwise the protection is lost.

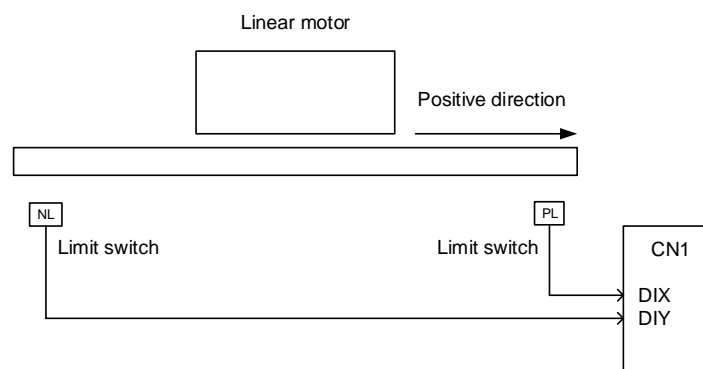

#### 11.7.4 Current setting for initial magnetic field detection

PM.011 (Current setting for initial magnetic field detection) is a parameter used for the linear motor without a Hall sensor (PM.003.Y = 0). When the linear motor without a Hall sensor is powered on and the servo is switched On for the first time, the servo drive outputs the current set in PM.011 to drive the motor and can obtain the motor's present magnetic field information by automatically detecting the initial magnetic field when the motor slightly moves. There are two modes for initial magnetic field detection: quick mode (PM.012 [Bit 14] = 0) and smooth mode (PM.012 [Bit 14] = 1).

During the detection, the current setting affects how subtle the movement of the linear motor is. With the appropriate current setting, the friction between the motor and the mechanical part can be overcome and the servo drive can complete the initial magnetic field detection. Excessive current causes excessive movement of the linear motor, which may result in mechanical part collision. On the other hand, when the current is too low, the friction may not be overcome and the servo drive is unable to detect the initial magnetic field, thus triggering AL052. For the settings of PM.011, refer to Chapter 8 Parameters.

When executing the motor parameter identification for the motor of the Z axis, ensure to place the translation stage under the mechanical part at a balanced position, and set PM.012 [Bit 12] and [Bit 13] according to the feedback position of the motor and the condition of the mechanical limits. Then, you can execute the initial magnetic field detection.

Note that if you are using a motor with a brake for the Z axis, it is prohibited to use the initial magnetic field detection function. Install a Hall sensor or use an absolute motor instead.

### 11.7.5 Overload gain

The overload gain setting is for protecting the motor from overheating. Under normal circumstances, set PM.019 and PM.020 to 100% (default) or adjust the values according to the following table. These parameters do not affect the motor performance. You can monitor the motor load (overload counter) with the monitoring variable -91, which value range is from 0 to 100. When the value reaches 100, it means the motor is overloaded and the servo alarm AL006 occurs.

The operating time in this section means the time required for the motor protection level to reach the overload level from the normal level. When the protection level reaches the overload level, AL006 is triggered. The measurement basis of the load ratio is 100%. When the ratio is above 100%, it refers to the Load increase gain (PM.019); when the ratio is less than 100%, it refers to the Load decrease gain (PM.020). The load ratio determines whether the overload count is accumulated. When the load ratio accumulates over 100%, the operating time must be taken into consideration, or else AL006 occurs. If the load ratio is below 100%, you do not need to consider the operating time.

Load ratio	Operating time	Load ratio	Operating time
0	12 sec × PM.020	260%	3.9 sec × PM.019
20%	12.3 sec × PM.020	280%	3.3 sec × PM.019
40%	13.6 sec × PM.020	300%	2.8 sec × PM.019
60%	16.3 sec × PM.020	320%	2.5 sec × PM.019
80%	22.6 sec × PM.020	340%	2.2 sec × PM.019
100%	N/A	360%	2.0 sec × PM.019
120%	263.8 sec × PM.019	380%	1.8 sec × PM.019
140%	35.2 sec × PM.019	400%	1.6 sec × PM.019
160%	17.6 sec × PM.019	420%	1.4 sec × PM.019
180%	11.2 sec × PM.019	440%	1.3 sec × PM.019
200%	8 sec × PM.019	460%	1.2 sec × PM.019
220%	6.1 sec × PM.019	480%	1.1 sec × PM.019
240%	4.8 sec × PM.019	500%	1 sec × PM.019

Note: for detailed parameter description, refer to Chapter 8 Parameters.



(This page is intentionally left blank.)

11

# CANopen Mode

# 12

This chapter provides details for the required parameter settings when the servo communicates with the controller through the CANopen communication function.

12.1	Basic configuration	12-2
12.1.1	Supported functions	12-2
12.1.2	Hardware configuration	12-3
12.1.3	Parameter settings in CANopen mode	12-4
12.2	Communication specification	12-5
12.2.1	Servo communication architecture	12-5
12.2.2	Communication objects	12-6
12.2.2.1	Process data object (PDO)	12-7
12.2.2.2	Service data object (SDO)	12-8
12.2.2.3	SDO abort codes	12-11
12.2.2.4	Synchronization object (SYNC)	12-12
12.2.2.5	Emergency object (EMCY)	12-13
12.2.2.6	NMT services	12-14
12.3	CANopen operation modes	12-17
12.3.1	Profile Position mode	12-17
12.3.2	Interpolated Position mode	12-22
12.3.3	Homing mode	12-25
12.3.4	Profile Velocity mode	12-27
12.3.5	Profile Torque mode	12-29
12.4	Object dictionary	12-31
12.4.1	Specifications for objects	12-31
12.4.2	List of objects	12-32
12.4.3	Details of objects	12-34
12.4.3.1	OD 1XXXh communication object group	12-34
12.4.3.2	OD 2XXXh servo parameter group	12-53
12.4.3.3	OD 6XXXh communication object group	12-54
12.5	Diagnostics and troubleshooting	12-96

## 12

## 12.1 Basic configuration

### 12.1.1 Supported functions

#### CANopen functions supported by Delta servo drives:

- CANopen communication objects: NMT, SYNC, SDO, PDO, and EMCY.
- SDO transmission: acyclic data exchange for reading / writing parameters and communication related settings.
- PDO transmission / reception: time-triggered, event-triggered, synchronous transmission (cyclic), and asynchronous transmission (acyclic).
- Node guarding.
- Heartbeat.

#### CANopen function not supported by Delta servo drives:

- Time stamp.

## 12.1.2 Hardware configuration

Pin assignment (RJ-45) for CAN bus wiring

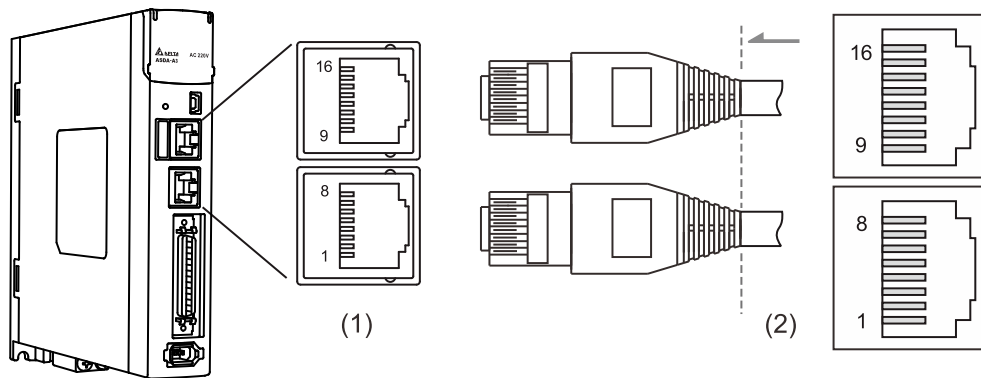

(1) CN3 connector (female); (2) CN3 connector (male)

Pin assignment:

Pin No.	Signal	Description
1	CAN_H	CAN_H bus line (dominant high)
2	CAN_L	CAN_L bus line (dominant low)
3, 7	GND_ISO	Signal GND
4	RS-485-	For the servo drive to transmit data to the differential terminal (-).
5	RS-485+	For the servo drive to transmit data to the differential terminal (+).
6, 8	-	Reserved
9	CAN_H	CAN_H bus line (dominant high)
10	CAN_L	CAN_L bus line (dominant low)
11, 15	GND_ISO	Signal GND
12	RS-485-	For the servo drive to transmit data to the differential terminal (-).
13	RS-485+	For the servo drive to transmit data to the differential terminal (+).
14, 16	-	Reserved

### ■ Baud rate setting

Baud rate and bus length

Baud rate	Maximum bus length
1 Mbps	25 m (82 ft)
800 Kbps	50 m (164 ft)
500 Kbps (default)	100 m (328 ft)
250 Kbps	250 m (820 ft)
125 Kbps	500 m (1640 ft)

### 12.1.3 Parameter settings in CANopen mode

Follow these instructions to connect the CANopen controller and the ASDA-A3 servo drive:

1. Set to CANopen mode: set P1.001.YX to 0C.
2. Set the node ID: set P3.000 to 0x0001 - 0x007F.
3. Set the transmission rate (baud rate): set P3.001.Z to 4 (Z = 0: 125 Kbps; 1: 250 Kbps; 2: 500 Kbps; 3: 800 Kbps; 4: 1 Mbps).
4. It is suggested that you change the setting value of P3.012.Z from 0 (default) to 1 to enable the non-volatile setting for the parameter. Note that the default E-Gear ratio varies with the set value of P3.012.Z.

Function	P3.012 = 0x0100 (Z = 1)		P3.012 = 0x0000 (Z = 0)	
	Servo parameter	Default	OD address	Default
Motor stop mode	P1.032	0x0000	605Bh	0
S-curve acceleration constant	P1.034	200	6087h	200
Zero speed range	P1.038	100 (rotary*: 0.1 rpm; linear*: 0.1 mm/s)	606Fh	100 (0.1 rpm)
E-Gear ratio - numerator N1	P1.044	16777216	6093h sub1	1
E-Gear ratio - denominator M	P1.045	100000	6093h sub2	1
Speed reached (DO.SP_OK) range	P1.047	10 (rotary*: rpm; linear*: mm/s)	606Dh	100 (0.1 rpm)
Accumulated time to reach desired speed	P1.049	0	606Eh	0
Maximum speed limit	P1.055	Depending on the motor (rotary*: 1 rpm; linear*: 1 mm/s)	607Fh	Depending on the motor (0.1 rpm)
			6080h	Depending on the motor (rpm)
Excessive deviation warning condition of Position command	P2.035	50331648	6065h	50331648
Positive software limit (PP / CSP / CSV / CST mode)	P5.008	2147483647	607Dh sub2	2147483647
Negative software limit (PP / CSP / CSV / CST mode)	P5.009	-2147483648	607Dh sub1	-2147483648
Origin definition (HM mode)	P6.001	0	607Ch	0

Note: rotary means a permanent-magnet synchronous rotary motor;  
linear means a permanent-magnet synchronous linear motor.

5. It is suggested that you enable the dynamic brake function (P1.032 = 0x0000).

## 12.2 Communication specification

### 12.2.1 Servo communication architecture

12

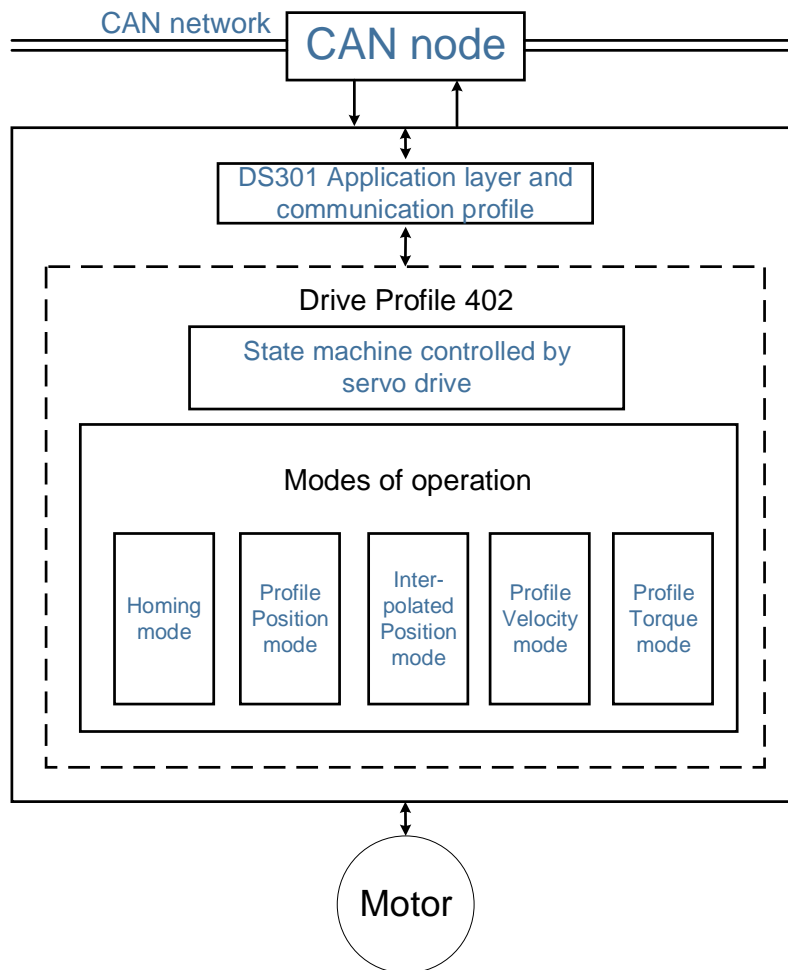

The CANopen architecture of the servo drive is as follows:

- DS301 is the communication profile. This protocol includes the communication objects (PDO, SDO, SYNC, and Emergency object), NMT service, and related communication object dictionary.
- DS402 is the device profile for drives and motion control. It defines the behavior of each operation mode and the required object parameter settings for execution.

## 12

## 12.2.2 Communication objects

The default values of the Delta servo drive object dictionary comply with the DS301 protocol. All CANopen data contains an 11-bit identifier, generally referred to as "COB-ID". The COB-ID data format is as follows:



Bit	Function	Description
Bit 0 - Bit 6	Node-ID	The data size is 7-bit and the setting range is 1 - 127.
Bit 7 - Bit 10	Function code	The data size is 4-bit and the setting range is 0 - 15.

The following table lists the supported objects and the corresponding COB-IDs:

Communication object	Function code Bit [10 9 8 7]	Node ID Bit [6 5 4 3 2 1 0]	COB-ID DEC (HEX)	Object index
NMT service	0 0 0 0	0 0 0 0 0 0 0	0 (0h)	-
SYNC object	0 0 0 1	0 0 0 0 0 0 0	128 (80h)	1005h, 1006h
EMCY object	0 0 0 1	X X X X X X X	128 (80h) + Node-ID	1014h
TxPDO1	0 0 1 1	X X X X X X X	384 (180h) + Node-ID	1800h
RxPDO1	0 1 0 0	X X X X X X X	512 (200h) + Node-ID	1400h
TxPDO2	0 1 0 1	X X X X X X X	640 (280h) + Node-ID	1801h
RxPDO2	0 1 1 0	X X X X X X X	768 (300h) + Node-ID	1401h
TxPDO3	0 1 1 1	X X X X X X X	896 (380h) + Node-ID	1802h
RxPDO3	1 0 0 0	X X X X X X X	1024 (400h) + Node-ID	1402h
TxPDO4	1 0 0 1	X X X X X X X	1152 (480h) + Node-ID	1803h
RxPDO4	1 0 1 0	X X X X X X X	1280 (500h) + Node-ID	1403h
TxSDO	1 0 1 1	X X X X X X X	1408 (580h) + Node-ID	1200h
RxSDO	1 1 0 0	X X X X X X X	1536 (600h) + Node-ID	1200h
NMT error control	1 1 1 0	X X X X X X X	1792 (700h) + Node-ID	1016h, 1017h

Note: 0 indicates the bit is off, 1 indicates the bit is on, and X indicates the bit is set according to the requirement.

Communication object dictionary:

Communication object index	Object area
1000h - 1FFFh	Communication Profile Area
2000h - 2FFFh	Manufacturer Specific Profile Area
6000h - 9FFFh	Standardized Device Profile Area

### 12.2.2.1 Process data object (PDO)

Real-time data transmission can be achieved with Process data objects (PDOs). There are two types of PDOs: transmit PDOs (TxPDOs) and receive PDOs (RxPDOs). This definition is from the perspective of the servo drive, for example, the TxPDO refers to the object that the servo drive sends to the controller. Set the communication parameters and mapping parameters as shown in the following table to use the PDOs.

RxPDOs			TxPDOs		
Communication object	Communication object index	Mapping object index	Communication object	Communication object index	Mapping object index
RxPDO1	1400h	1600h	TxPDO1	1800h	1A00h
RxPDO2	1401h	1601h	TxPDO2	1801h	1A01h
RxPDO3	1402h	1602h	TxPDO3	1802h	1A02h
RxPDO4	1403h	1603h	TxPDO4	1803h	1A03h

The format of PDO mapping parameter is:

Bit	31	30	29	28	27	26	25	24	23	22	21	20	19	18	17	16
Bit	15	14	13	12	11	10	9	8	7	6	5	4	3	2	1	0

Bit	Function
Bit 0 - Bit 7	Object data length
Bit 8 - Bit 15	Object sub-index
Bit 16 - Bit 31	Object index

Example:

To set the three PDOs, OD 6040h, OD 607Ah, and OD 6060h, in the first group of PDOs, the setting is as follows:

Mapping parameter setting for RxPDO	Data			Description
OD 1600h sub0	3			Set 3 PDO mappings.
OD 1600h sub1	6040h	00h	10h	-
OD 1600h sub2	607Ah	00h	20h	-
OD 1600h sub3	6060h	00h	08h	-
Note	The total length is 38h (56-bit) which meets the specification of less than 64-bit.			



# 12

## 12.2.2.2 Service data object (SDO)

With Service data objects (SDOs), you can write or read objects. The SDO message format is mainly composed of COB-ID and SDO packets. SDO packets can transmit up to 4 bytes.

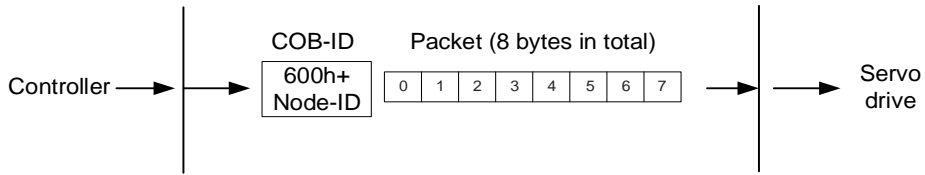

Byte	Function
Byte 0	Command code
Byte 1 - Byte 2	Object index
Byte 3	Object sub-index
Byte 4 - Byte 7	Data

### Write data with SDO

To use an SDO to write data with the controller, you need to write the command code, indexes, and data according to the SDO format. The servo drive then returns the corresponding message based on the written data.

The following figure shows the packet format when the controller sends the SDO for writing data:

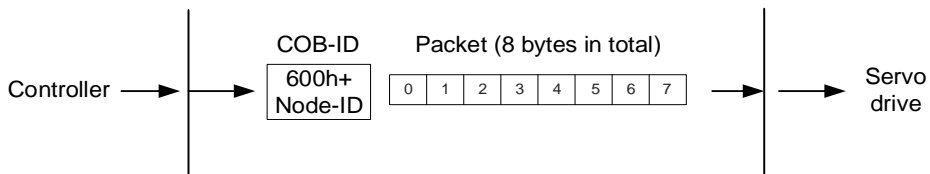

Command code	Object index		Object sub-index	Data				Description
	Byte 1	Byte 2		Byte 4	Byte 5	Byte 6	Byte 7	
23h	-	-	-	Data				Write 4 bytes of data.
2Bh	-	-	-	Data				Write 2 bytes of data.
2Fh	-	-	-	Data				Write 1 byte of data.

The following figure shows the packet format returned by the servo drive when the controller sends the SDO for writing data:

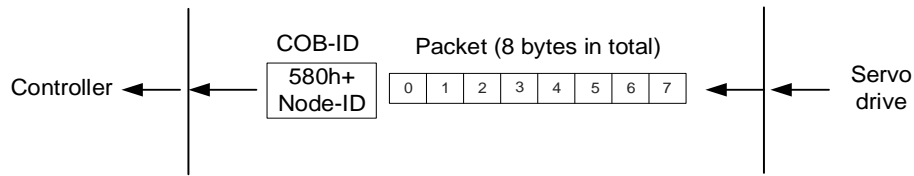

12

Command code	Object index		Object sub-index	Data				Description
	Byte 1	Byte 2		Byte 3	Byte 4	Byte 5	Byte 6	
60h	-	-	-	/	/	/	/	Write-in is successful.
80h	-	-	-	SDO abort codes				Error code.

Note: for SDO abort codes, refer to Section 12.2.2.3.

Example:

Write the value of 300,000 (493E0h) to the servo parameter P7.001 (OD 2701h).

The write-in format is as follows:

Command code	Object index		Object sub-index	Data				Description
	Byte 1	Byte 2		Byte 3	Byte 4	Byte 5	Byte 6	
23h	01	27	0	E0	93	04	00	Write 4 bytes of data.

The returned packet is as follows:

Command code	Object index		Object sub-index	Data				Description
	Byte 1	Byte 2		Byte 3	Byte 4	Byte 5	Byte 6	
60h	01	27	0	/	/	/	/	Write-in is successful.

# 12

■ Read data with SDO

To use an SDO to read data with the controller, you need to write the command code and indexes according to the SDO format. The servo drive then returns the object's data based on the object to be read.

The following figure shows the packet format when the controller sends the SDO for reading data:

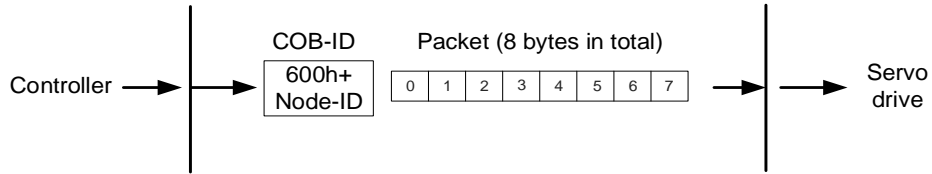

Command code	Object index		Object sub-index	Data				Description
	Byte 0	Byte 1	Byte 2	Byte 3	Byte 4	Byte 5	Byte 6	
40h	-	-	-					Read data.

The following figure shows the packet format returned by the servo drive when the controller sends the SDO for reading data:

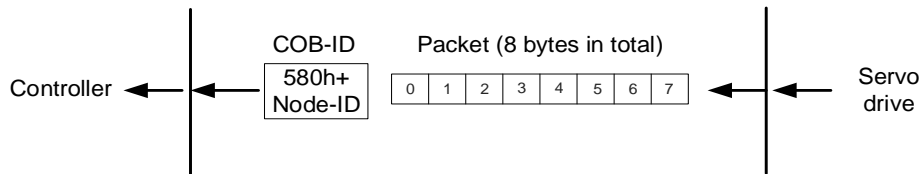

Command code	Object index		Object sub-index	Data				Description
	Byte 0	Byte 1	Byte 2	Byte 3	Byte 4	Byte 5	Byte 6	
43h	-	-	-	Data				Read 4 bytes of data.
4Bh	-	-	-	Data				Read 2 bytes of data.
4Fh	-	-	-	Data				Read 1 byte of data.
80h	-	-	-	SDO abort codes				Error code.

Note: for SDO abort codes, refer to Section 12.2.2.3.

### 12.2.2.3 SDO abort codes

The abort codes are as follows:

SDO abort code	Description
05040001h	Client / Server command is invalid or unknown.
06010002h	Attempt to write a read-only object.
06020000h	Object does not exist in the object dictionary.
06040041h	Unable to map the object to the PDO.
06040042h	The number and length of the objects to be mapped would exceed the PDO length.
06060000h	Access failed due to hardware error (storage or restore error).
06070010h	Data type does not match; parameter data length does not match.
06090011h	Sub-index does not exist.
06090030h	Invalid parameter value (write access only).
08000000h	General error.
080000a1h	An error occurred when an object is read from EEPROM.
080000a2h	An error occurred when an object is written to EEPROM.
080000a3h	Invalid range when accessing EEPROM.
080000a4h	Data content error occurred when EEPROM is accessed.
080000a5h	The entered password is incorrect when data is written to the encryption area.
08000020h	Unable to transfer data or save data to the application.
08000021h	Unable to transfer data or save data to the application due to local control (storage or restore in the wrong state).
08000022h	Object is in use.

# 12

## 12.2.2.4 Synchronization object (SYNC)

The Synchronization objects (SYNCs) are periodically broadcast by the SYNC producer. There is no data in the SYNC packet (L = 0).

The SYNC protocol is as follows:

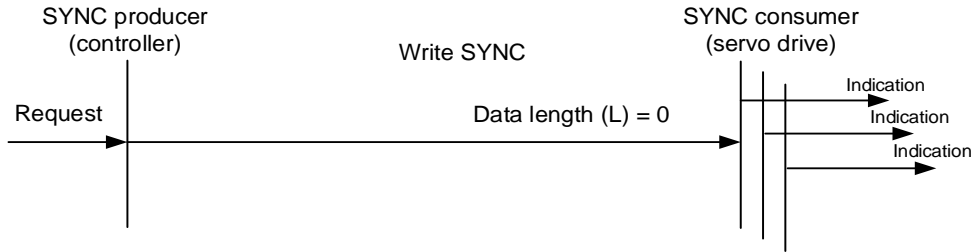

The SYNC object is used to achieve the synchronization of PDO transmission and reception between the controller and servo drive. The SYNC object transmission cycle is set by the object OD 1006h (see Section 12.4 Object dictionary for detailed settings).

The following figure shows the timing sequence between the servo drive RxPDO reception and the controller SYNC transmission. The controller transmits RxPDO to the servo drive between two SYNCs (communication cycle), and the servo drive will not execute the RxPDO received in the previous communication cycle until it receives the SYNC.

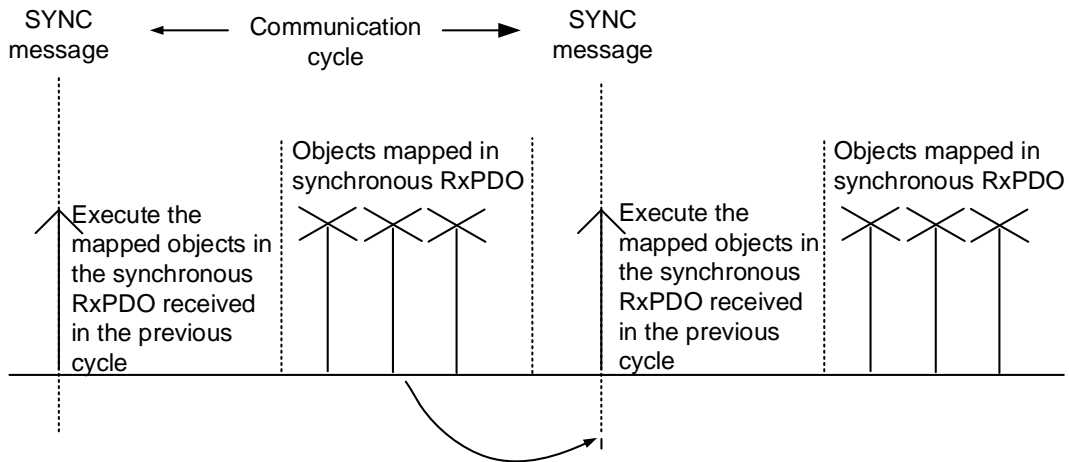

The following figure shows the timing sequence between the servo drive TxPDO transmission and the controller SYNC transmission. The servo drive transmits the TxPDO data to the controller as soon as it receives the SYNC.

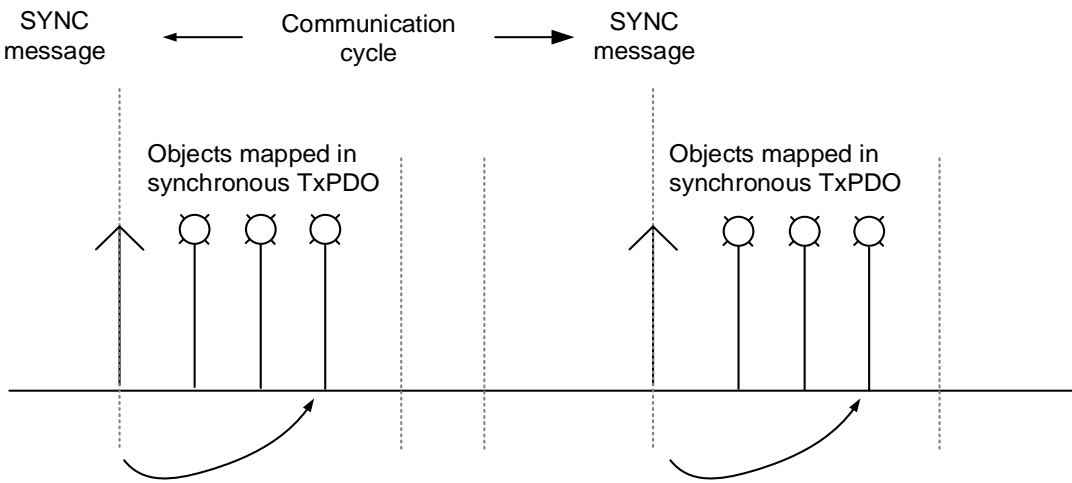

**12.2.2.5 Emergency object (EMCY)**

When the servo detects an abnormality, it sends an alarm and notifies the controller with the Emergency object. The Emergency object can transmit only one alarm at a time. When a higher priority alarm occurs before the previous lower priority alarm is cleared, the higher priority alarm overwrites the previous alarm and is transmitted to the controller as an Emergency object.

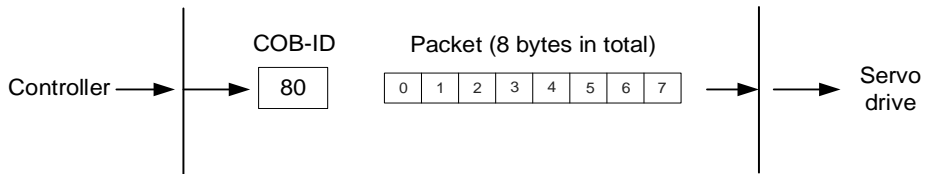

Error code		Error register	Servo alarm	N/A
Byte 0	Byte 1	Byte 2	Byte 3	Bytes 4 - 7
Refer to Section 13.5.2 for details of the error code.		OD 1001h	Refer to Chapter 14 for details.	

12.2.2.6 NMT services

■ State machine

12

The NMT state machine is shown as follows. After the servo drive completes the initialization, it enters the Pre-Operational state. The NMT state machine determines the behavior of the communication objects, such as PDO functions only in the Operational state.

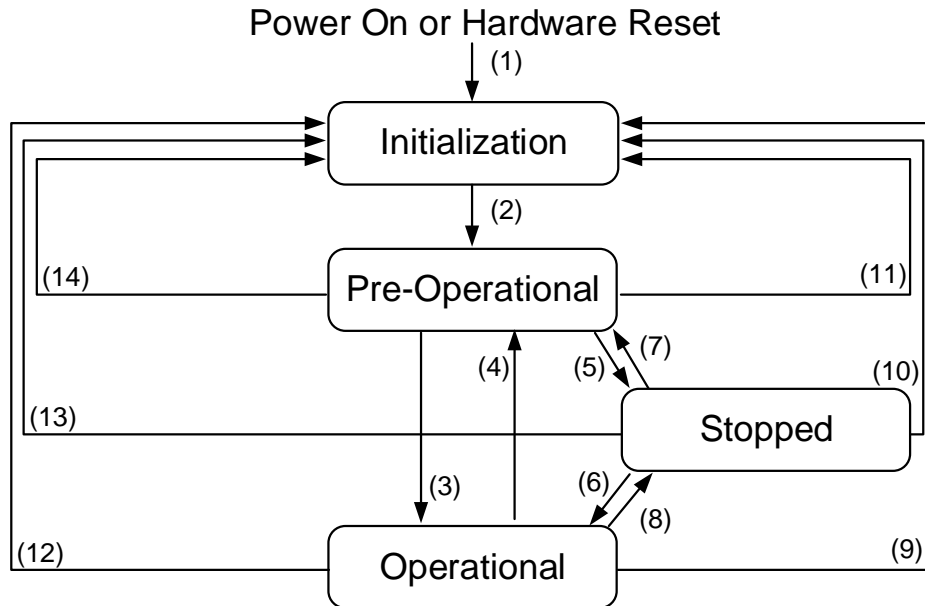

Status	Description
Initialization	The servo drive successfully completes initialization after being powered on without errors occurring. The packets cannot yet be transmitted in this state.
Pre-Operational	Data can be exchanged with SDOs. If an alarm occurs in the servo drive, an emergency message is sent to notify the controller.
Stopped	The servo drive can use SDO and TxPDO data packets to exchange data with the controller.
Operational	All data exchanges including SDOs and PDOs (TxPDOs and RxPDOs) are allowed.

The following table shows the available communication objects in each communication state:

Communication object	Initialization	Pre-Operational	Operational	Stopped
PDO			V	TxPDO
SDO		V	V	V
Synchronization object		V	V	
Emergency object		V	V	
Boot-up object	V			
NMT object		V	V	V

■ Heartbeat

The Heartbeat mechanism is mainly to enable the producer to send packets to the consumer periodically. The producer can be a controller or servo drive; on the other hand, a controller or servo drive can also be the consumer.

If you use the controller to send the heartbeat and the servo drive as the consumer, you need to set the consumer heartbeat time (OD 1016h) for the servo drive. When the servo drive does not receive the heartbeat signal within the receiving time, it triggers the heartbeat event, meaning AL180 is triggered. Consumer heartbeat time (OD 1016h) is defined as the time the servo drive expects to receive a heartbeat. To start the Heartbeat mechanism, set the consumer heartbeat time (OD 1016h) and then have the controller send the heartbeat signal. The consumer heartbeat time (OD 1016h) must be greater than the producer heartbeat time which is set by the controller. Since there are delays and other uncontrollable external factors in transmitting the heartbeat message, you must retain a tolerance time for the transmission.

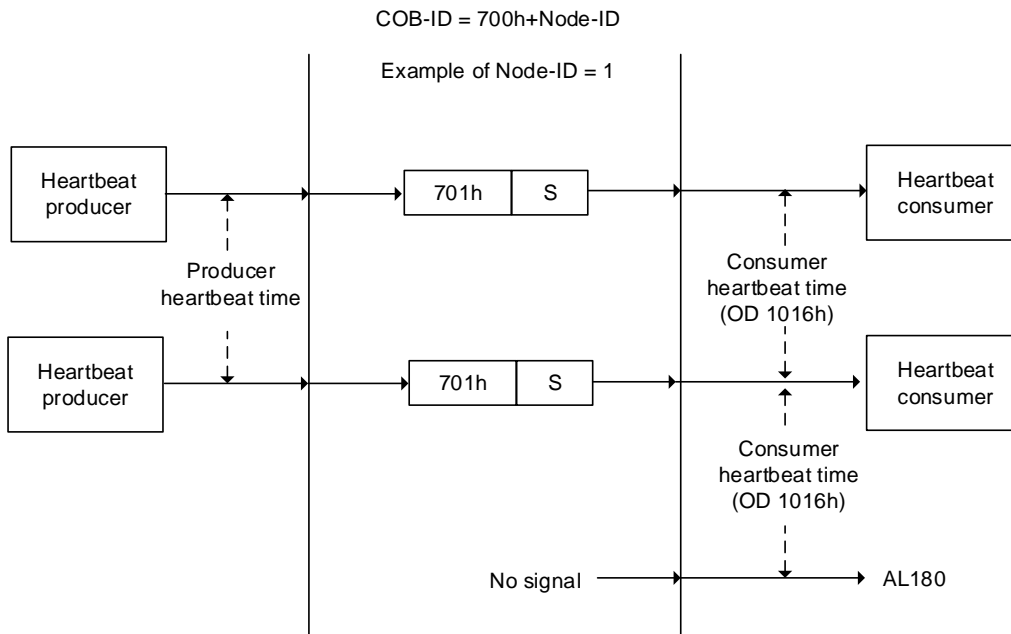

The S code is described as follows:

S	State
0	Bootup
4	Stopped
5	Operational
127	Pre-Operational

If you want to use the servo drive as the producer, then the heartbeat is sent by the drive. When the controller does not receive the heartbeat signal within the receiving time, it triggers the heartbeat event which corresponds to the alarm defined by the controller.

The servo drive can be the consumer and the producer simultaneously. In that case, you need to set OD 1016h and OD 1017h at the same time, and the controller must be set as the producer and the consumer as well.



# 12

■ Node/Life guarding

The Node/Life guarding mechanism is similar to the Heartbeat mechanism. The main difference between the two is that Heartbeat only uses the consumer but not the producer to judge whether there are packets or not. The mechanism of Node/Life guarding is mainly based on the two-way relationship between the master and slave. The master periodically sends packets to the slave, and the slave must return the packets to the master within the set guard time (OD 100Ch), otherwise an error occurs. You must set the life time for the slave and the master must send the packets within the guard time. If the slave does not receive the packets, AL180 is triggered. Life time is set by multiplying the guard time by a life time factor (OD 100Dh).

The Node/Life Guarding architecture is as follows:

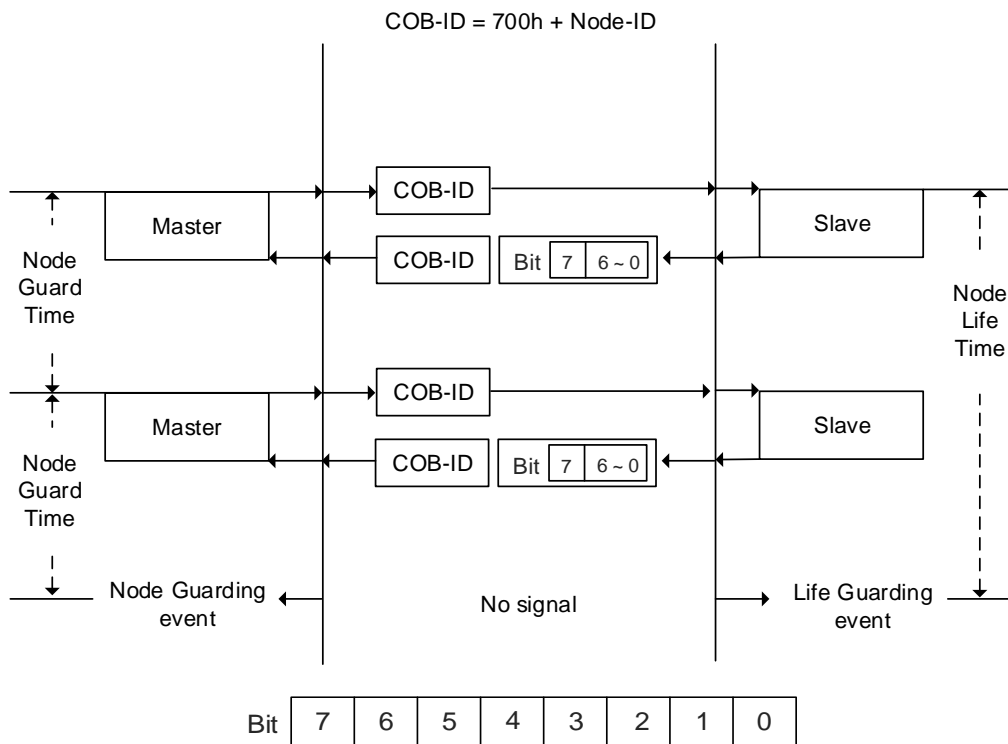

Bit	Function	Description
Bit 0 - Bit 6	State of the NMT slave	4 = Stopped 5 = Operational 127 = Pre-Operational
Bit 7	Reserved	-

## 12.3 CANopen operation modes

This section describes the modes of operation specified by CiA DS402 when the servo is in the CANopen mode. The content includes basic operation settings and related object descriptions.

12

### 12.3.1 Profile Position mode

After receiving the position command transmitted from the controller, the servo drive controls the servo motor to reach the target position.

In Profile Position (PP) mode, the controller only informs the servo drive of the target position, speed command, and acceleration / deceleration settings at the beginning. The motion planning from command triggering to the arrival of the target position is performed by the trajectory generator in the servo drive.

The following figure shows the Profile Position mode architecture of the servo drive:

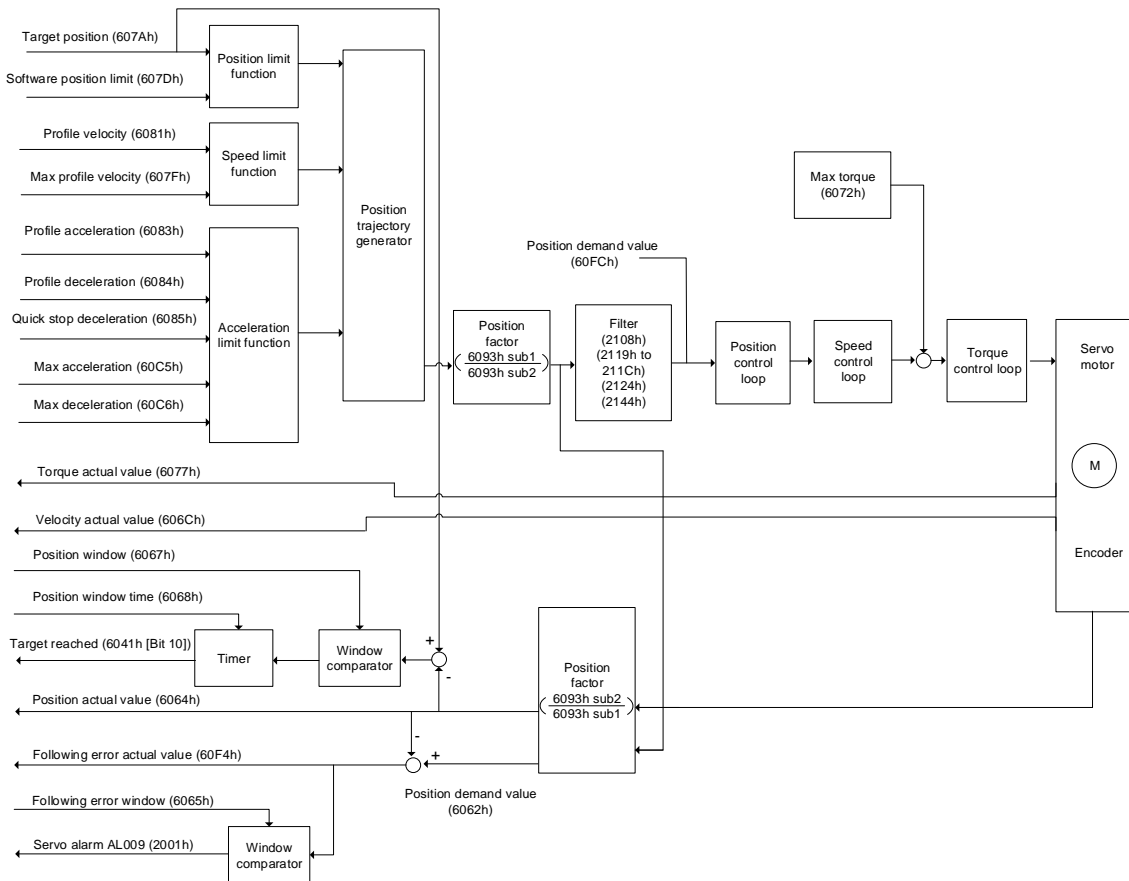

## 12

Operation steps:

1. Set OD 6060h to 01h to set the mode as Profile Position mode.
2. Set OD 607Ah for the target position (unit: PUU).
3. Set OD 6081h for the profile velocity (unit: PUU/sec).
4. Set OD 6083h for the profile acceleration (unit: ms).
5. Set OD 6084h for the profile deceleration (unit: ms).
6. Set the Controlword (OD 6040h). Follow these steps for operation. Steps 6.1 and 6.2 are to bring the servo drive's state machine into the ready state. For the description of the state machine, refer to the OD 6040h description in Section 12.4.3.3.

Step	Bit 4	Bit 3	Bit 2	Bit 1	Bit 0	Description
6.1	0	0	1	1	0	Shutdown.
6.2	0	0	1	1	1	Switch on (ready for Servo On).
6.3	0	1	1	1	1	Enable operation (Servo On).
6.4	1	1	1	1	1	Command triggering (rising-edge triggered)

7. After the servo completes the first motion command, the servo sets the target position, speed, and other conditions to execute the next motion command.
8. Set the Controlword (OD 6040h). Since the command is rising-edge triggered, switch Bit 4 to Off first and then to On.

Step	Bit 4	Bit 3	Bit 2	Bit 1	Bit 0	Description
8.1	0	1	1	1	1	Enable operation (Servo On).
8.2	1	1	1	1	1	Command triggering (rising-edge triggered)

Read the servo drive information:

1. Read OD 6064h to obtain the actual value of the motor position at present.
2. Read OD 6041h to obtain the servo drive status, including the following error and notifications for set-point acknowledge and target reached.

### Function for the command to take immediate effect

In Profile Position mode, set the command to take effect immediately or not with OD 6040h [Bit 5].

- Set OD 6040h [Bit 5] to 0 to disable the command from taking immediate effect

If the command is not enabled to take immediate effect, when the current motion command is in execution (not yet complete), the servo continues to execute the current motion command even if a new command is triggered. The new command is acknowledged and executed only after the current command is complete.

12

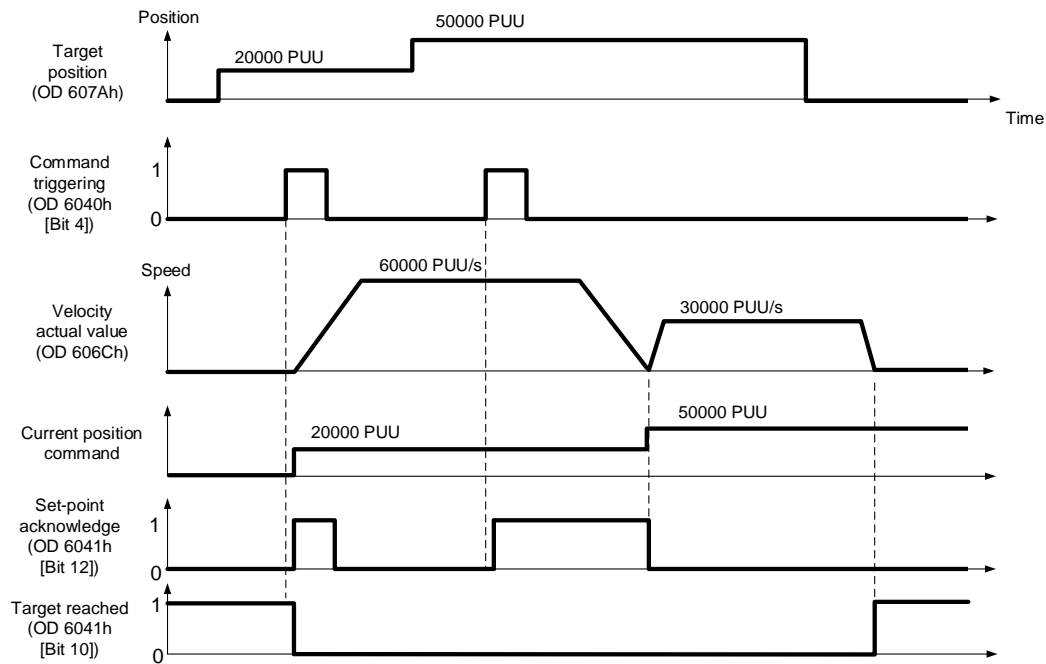

## 12

- Set OD 6040h [Bit 5] to 1 to enable the command to take immediate effect (only valid in Profile Position mode)

If the command is enabled to take immediate effect, when the current motion command is in execution (not yet complete), the servo immediately interrupts the current command and executes the new command once receiving the new triggered command.

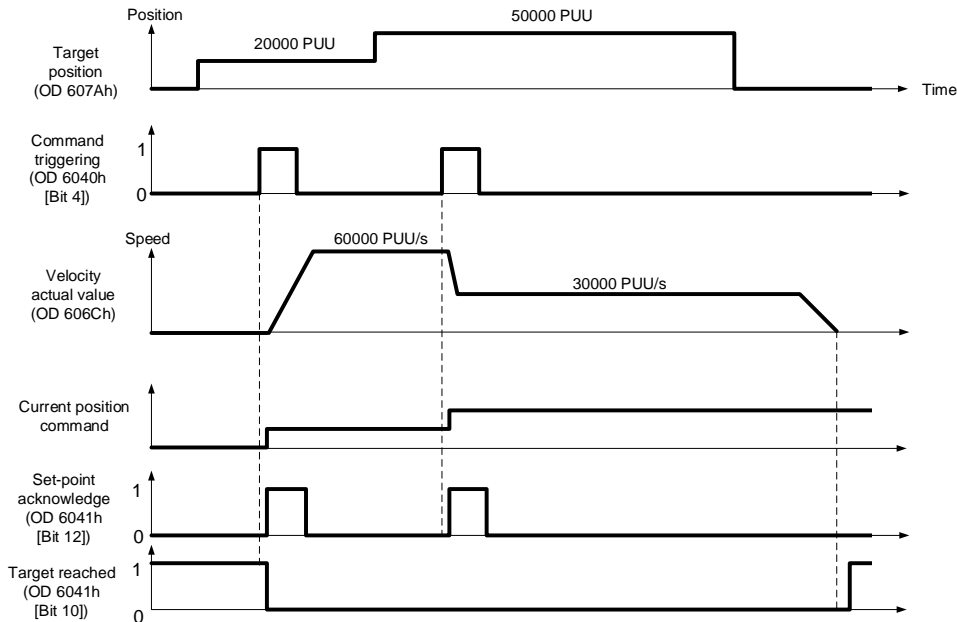

## Relevant object list

Index	Name	Data type	Access
6040h	Controlword	UNSIGNED16	RW
6041h	Statusword	UNSIGNED16	RO
6060h	Modes of operation	INTEGER8	RW
6061h	Modes of operation display	INTEGER8	RO
6062h	Position demand value [PUU]	INTEGER32	RO
6063h	Position actual internal value [Pulse]	INTEGER32	RO
6064h	Position actual value [PUU]	INTEGER32	RO
6065h	Following error window	UNSIGNED32	RW
6067h	Position window	UNSIGNED32	RW
6068h	Position window time	UNSIGNED16	RW
606Ch	Velocity actual value	INTEGER32	RO
6072h	Max torque	UNSIGNED16	RW
6077h	Torque actual value	INTEGER16	RO
607Ah	Target position	INTEGER32	RW
607Dh	Software position limit	INTEGER32	RW
607Fh	Max profile velocity	UNSIGNED32	RW
6081h	Profile velocity	UNSIGNED32	RW
6083h	Profile acceleration	UNSIGNED32	RW
6084h	Profile deceleration	UNSIGNED32	RW
6085h	Quick stop deceleration	UNSIGNED32	RW
6093h	Position factor	UNSIGNED32	RW
60C5h	Max acceleration	UNSIGNED32	RW

Index	Name	Data type	Access
60C6h	Max deceleration	UNSIGNED32	RW
60F4h	Following error actual value	INTEGER32	RO
60FCh	Position demand value	INTEGER32	RO

Note: for more details, refer to Section 12.4.3 Details of objects.

# 12

## 12.3.2 Interpolated Position mode

Interpolated Position (IP) mode requires a series of position data to complete the interpolation for positioning. Different from PP (Profile Position) mode, all the motion command paths in IP mode are issued by the controller. The servo drive only follows each position that the controller issues and finally completes a motion command. Delta servo drives only support synchronous operation in which the controller periodically sends the SYNC object (COB-ID = 0x80). The interpolation time period can be set with OD 60C2h. And the controller issues the position command to the interpolation position of OD 60C1h.

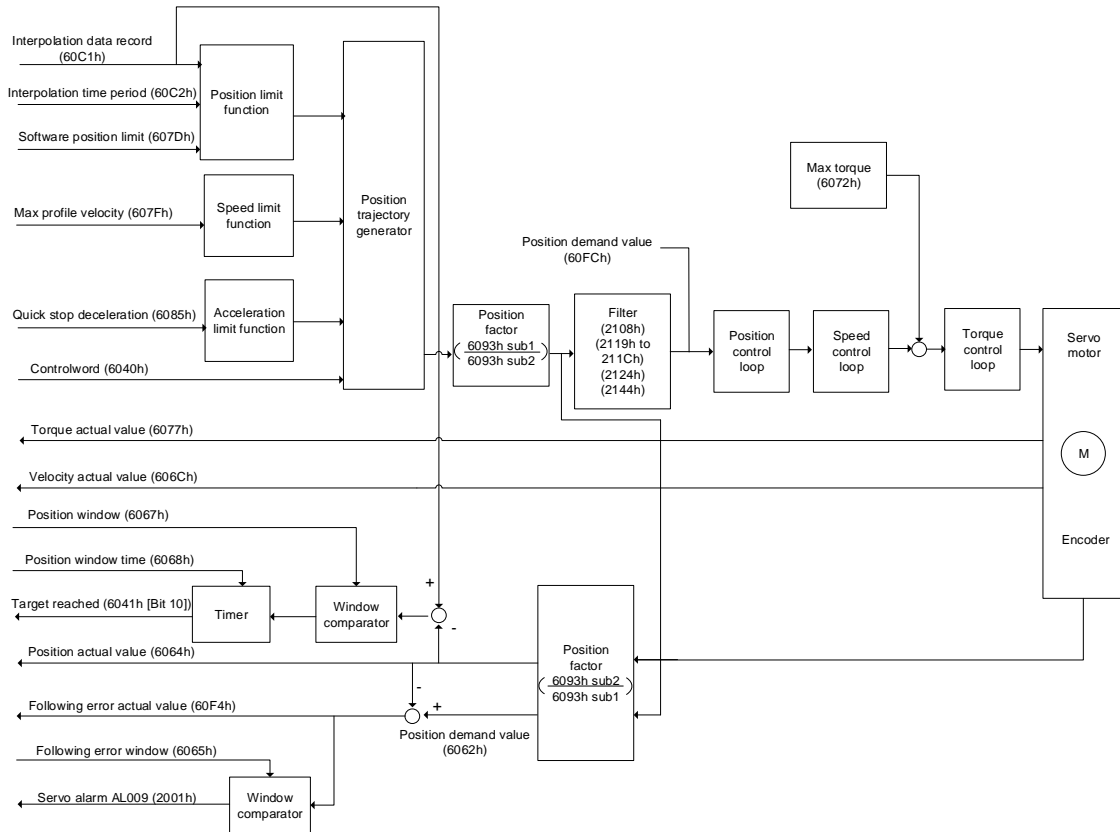

Operation steps:

1. Set OD 6060h to 07h to set the mode as Interpolated Position mode.
2. Set OD 60C2h for the interpolation time period. The setting must be the same as the communication cycle period (OD 1006h).
3. In the PDO mapping setting of the controller, configure one set of RxPDO to be OD 60C1h sub1 and OD 60C1h sub2.
4. In the PDO mapping setting of the controller, configure the objects to be monitored in TxPDO according to the requirements, such as the position actual value (OD 6064h).
5. Set the Controlword (OD 6040h). Follow these steps for operation. Steps 5.1 and 5.2 are to bring the servo drive's state machine into the ready state. For more details of the state machine, refer to the OD 6040h description in Section 12.4.3.3.

Step	Bit 4	Bit 3	Bit 2	Bit 1	Bit 0	Description
5.1	0	0	1	1	0	Shutdown.
5.2	0	0	1	1	1	Switch on (ready for Servo On).
5.3	0	1	1	1	1	Enable operation (Servo On).

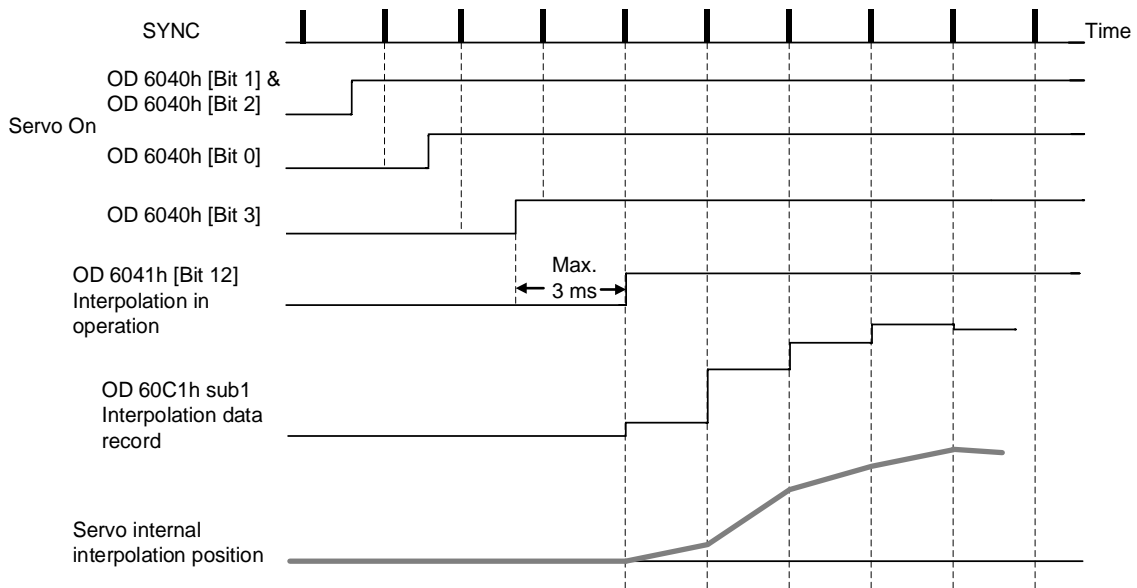



## 12

Adjustment method:

It is suggested that you set the SYNC communication cycle period (OD 1006h) between 1 ms and 10 ms. If the cycle period is too long, the interval between cycles also increases. If the position change is big, it causes speed fluctuations. In this case, use P1.036 (S-curve acceleration / deceleration constant) or P1.068 (Position command - moving filter) to smooth the position difference. Since the jitter of each controller is different, the time the servo receives the SYNC differs from the SYNC communication cycle time. When this happens, adjust the value of P3.009.U to increase the error range and have the servo drive automatically correct the internal timer so it is consistent with the communication cycle of the controller.

Relevant object list

Index	Name	Data type	Access
6040h	Controlword	UNSIGNED16	RW
6041h	Statusword	UNSIGNED16	RO
6060h	Modes of operation	INTEGER8	RW
6061h	Modes of operation display	INTEGER8	RO
6093h	Position factor	UNSIGNED32	RW
60C0h	Interpolation sub mode select	INTEGER16	RW
60C1h	Interpolation data record	INTEGER32	RW

Note: for more details, refer to Section 12.4.3 Details of objects.

### 12.3.3 Homing mode

After homing is complete, the position system of the servo drive is established and the drive can start executing the position command issued by the controller. The Delta A3 servo drive offers 39 homing methods, including homing on the home switch, positive or negative limit, motor Z pulse, and hard stop.

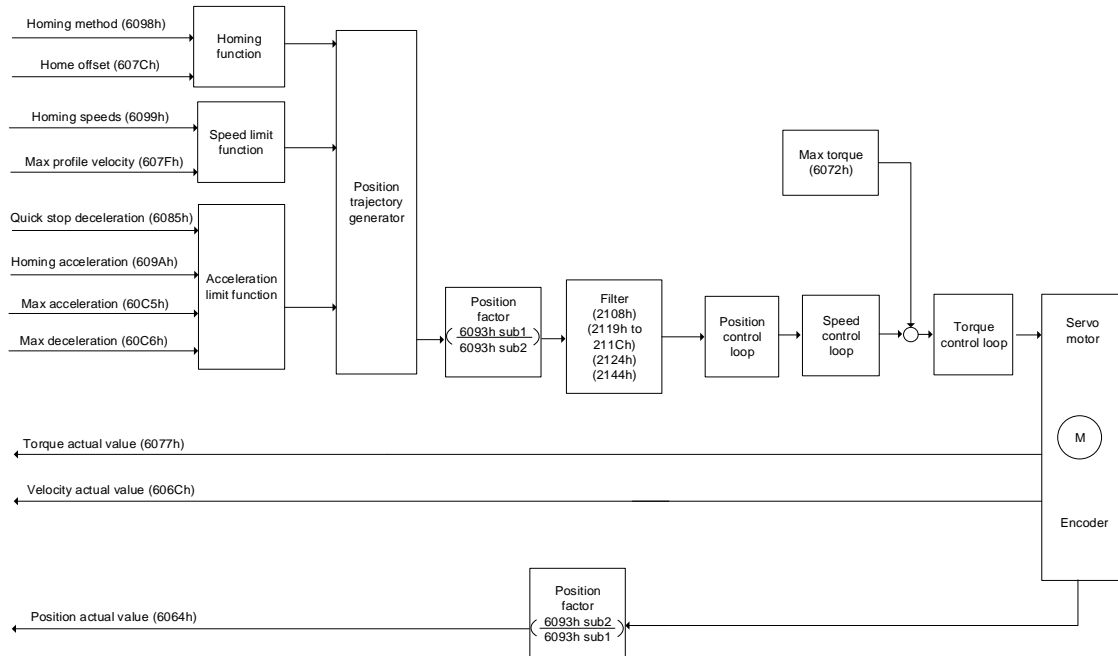

Operation steps:

1. Set OD 6060h to 06h to set the mode as Homing mode.
2. Set OD 607Ch for the home offset.
3. Set OD 6098h for the homing method.
4. Set OD 6099h sub1 for the speed when searching for the home switch.
5. Set OD 6099h sub2 for the speed when searching for the Z pulse.
6. Set OD 609Ah for the homing acceleration.
7. Set the Controlword (OD 6040h). Follow these steps for operation. Steps 7.1 and 7.2 are to bring the servo drive's state machine into the ready state. For more details of the state machine, refer to the OD 6040h description in Section 12.4.3.3.

Step	Bit 4	Bit 3	Bit 2	Bit 1	Bit 0	Description
7.1	0	0	1	1	0	Shutdown.
7.2	0	0	1	1	1	Switch on (ready for Servo On).
7.3	0	1	1	1	1	Enable operation (Servo On).
7.4	1	1	1	1	1	Homing (rising-edge triggered).

Read the servo drive information:

1. Read OD 6041h to obtain the servo drive status.
2. Read OD 6064h to obtain the actual value of the motor position at present.

# 12

Relevant object list

Index	Name	Data type	Access
6040h	Controlword	UNSIGNED16	RW
6041h	Statusword	UNSIGNED16	RO
6060h	Modes of operation	INTEGER8	RW
6061h	Modes of operation display	INTEGER8	RO
6064h	Position actual value [PUU]	INTEGER32	RO
606Ch	Velocity actual value	INTEGER32	RO
6072h	Max torque	UNSIGNED16	RW
607Ch	Home offset	INTEGER32	RW
607Fh	Max profile velocity	UNSIGNED32	RW
6085h	Quick stop deceleration	UNSIGNED32	RW
6093h	Position factor	UNSIGNED32	RW
6098h	Homing method	INTEGER8	RW
6099h	Homing speeds	UNSIGNED32	RW
609Ah	Homing acceleration	UNSIGNED32	RW
60C5h	Max acceleration	UNSIGNED32	RW
60C6h	Max deceleration	UNSIGNED32	RW

Note: for more details, refer to Section 12.4.3 Details of objects.

### 12.3.4 Profile Velocity mode

In Profile Velocity (PV) mode, the controller specifies the speed command and acceleration / deceleration settings, and then the trajectory generator of the servo drive plans the motion path according to these conditions.

12

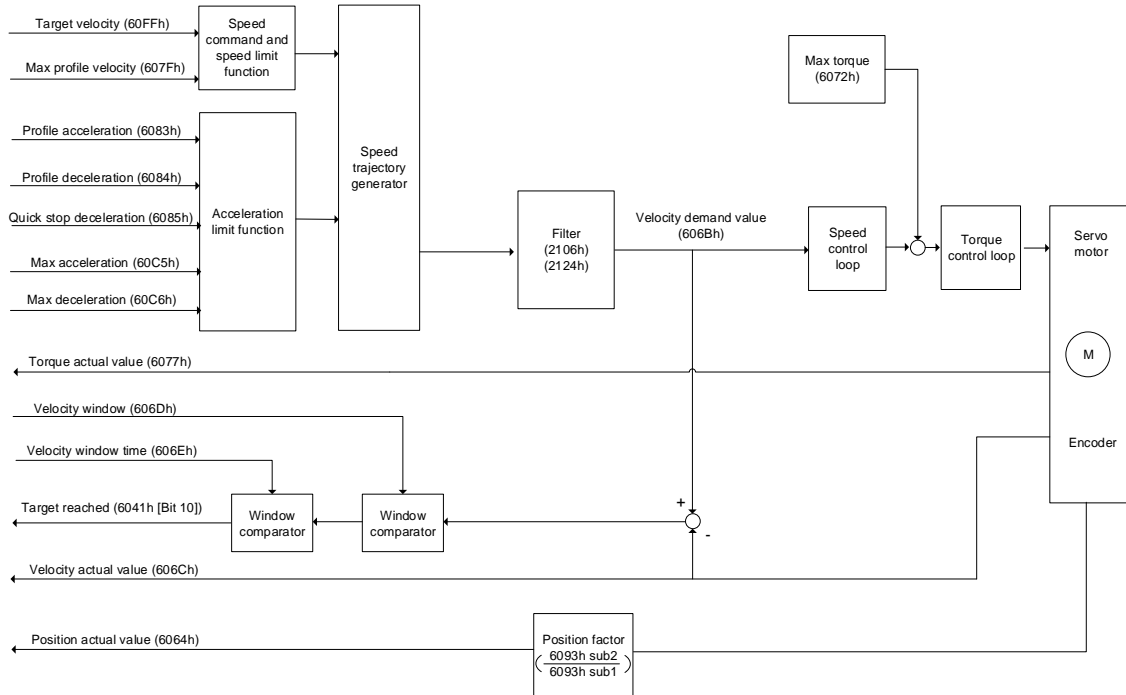

Operation steps:

1. Set OD 6060h to 03h to set the mode as Profile Velocity mode.
2. Set OD 6083h for the profile acceleration.
3. Set OD 6084h for the profile deceleration.
4. Set the target velocity (OD 60FFh) to 0. In Profile Velocity mode, the servo motor starts operating once the servo drive is switched to Servo On (Step 5). Therefore, setting the target velocity (OD 60FFh) to 0 is to ensure that the motor maintains at 0 rpm at the moment of Servo On.
5. Set the Controlword (OD 6040h). Follow these steps for operation. Steps 5.1 and 5.2 are to bring the servo drive's state machine into the ready state. For more details of the state machine, refer to the OD 6040h description in Section 12.4.3.3.

Step	Bit 4	Bit 3	Bit 2	Bit 1	Bit 0	Description
5.1	0	0	1	1	0	Shutdown.
5.2	0	0	1	1	1	Switch on (ready for Servo On).
5.3	0	1	1	1	1	Enable operation (Servo On).

6. Set OD 60FFh for the target velocity.

Read the servo drive information:

1. Read OD 6041h to obtain the servo drive status.
2. Read OD 606Ch to obtain the current speed feedback.

# 12

Relevant object list

Index	Name	Data type	Access
6040h	Controlword	UNSIGNED16	RW
6041h	Statusword	UNSIGNED16	RO
6060h	Modes of operation	INTEGER8	RW
6061h	Modes of operation display	INTEGER8	RO
6064h	Position actual value [PUU]	INTEGER32	RO
606Bh	Velocity demand value	INTEGER32	RO
606Ch	Velocity actual value	INTEGER32	RO
606Dh	Velocity window	UNSIGNED16	RW
606Eh	Velocity window time	UNSIGNED16	RW
606Fh	Velocity threshold	UNSIGNED16	RW
6072h	Max torque	UNSIGNED16	RW
6077h	Torque actual value	INTEGER16	RO
607Fh	Max profile velocity	UNSIGNED32	RW
6083h	Profile acceleration	UNSIGNED32	RW
6084h	Profile deceleration	UNSIGNED32	RW
6085h	Quick stop deceleration	UNSIGNED32	RW
6093h	Position factor	UNSIGNED32	RW
60C5h	Max acceleration	UNSIGNED32	RW
60C6h	Max deceleration	UNSIGNED32	RW
60FFh	Target velocity	INTEGER32	RW

Note: for more details, refer to Section 12.4.3 Details of objects.

## 12.3.5 Profile Torque mode

In Profile Torque (PT) mode, the controller specifies the torque command and filtering conditions, and then the trajectory generator of the servo drive plans the torque slope according to these conditions.

12

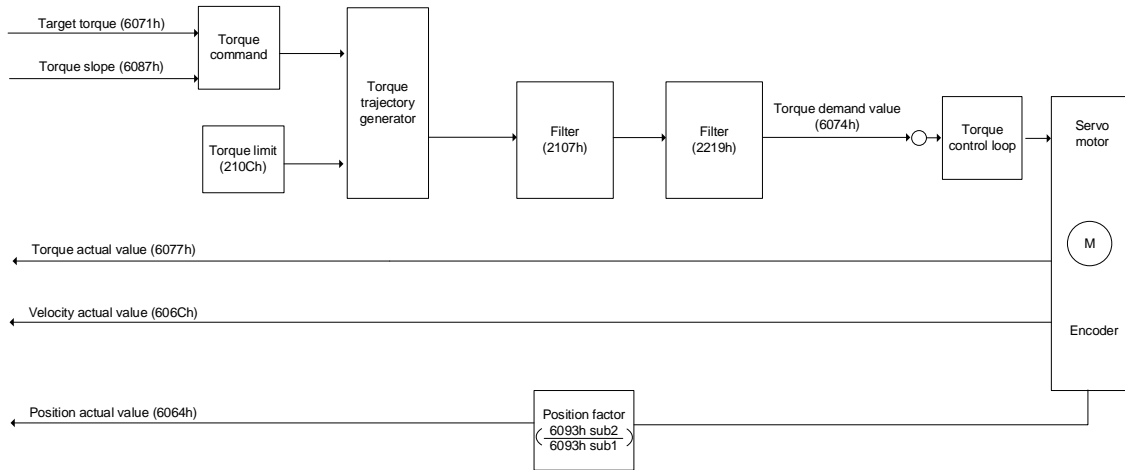

Operation steps:

1. Set OD 6060h to 04h to set the mode as Profile Torque mode.
2. Set OD 6087h for the torque slope.
3. Set the target torque (OD 6071h) to 0. In Profile Torque mode, the servo target torque takes effect once the servo drive is switched to Servo On (Step 4). Therefore, set the target torque (OD 6071h) to 0 for safety reasons.
4. Set the Controlword (OD 6040h). Follow these steps for operation. Steps 4.1 and 4.2 are to bring the servo drive's state machine into the ready state. For more details of the state machine, refer to the OD 6040h description in Section 12.4.3.3.

Step	Bit 4	Bit 3	Bit 2	Bit 1	Bit 0	Description
4.1	0	0	1	1	0	Shutdown.
4.2	0	0	1	1	1	Switch on (ready for Servo On).
4.3	0	1	1	1	1	Enable operation (Servo On).

5. Set OD 6071h for the target torque.

Read the servo drive information:

1. Read OD 6041h to obtain the servo drive status.
2. Read OD 6077h to obtain the current torque feedback.

# 12

Relevant object list

Index	Name	Data type	Access
6040h	Controlword	UNSIGNED16	RW
6041h	Statusword	UNSIGNED16	RO
6060h	Modes of operation	INTEGER8	RW
6061h	Modes of operation display	INTEGER8	RO
6064h	Position actual value [PUU]	INTEGER32	RO
606Ch	Velocity actual value	INTEGER32	RO
6071h	Target torque	INTEGER16	RW
6074h	Torque demand value	INTEGER16	RO
6075h	Motor rated current	UNSIGNED32	RO
6077h	Torque actual value	INTEGER16	RO
6078h	Current actual value	INTEGER16	RO
6087h	Torque slope	UNSIGNED32	RW
6093h	Position factor	UNSIGNED32	RW

Note: for more details, refer to Section 12.4.3 Details of objects.

## 12.4 Object dictionary

This section details the CANopen objects supported by the servo. The contents include object index, name, data type, data length, and read / write permissions (access).

### 12.4.1 Specifications for objects

#### Object code

Object code	Description
VAR	A single value, such as an UNSIGNED8, Boolean, float, and INTEGER16.
ARRAY	An object of multiple data fields consisting of multiple variables of the same data type, such as an UNSIGNED16 array. The sub-index 0 data type is UNSIGNED8, so it is not an ARRAY data.
RECORD	An object of multiple data fields consisting of multiple variables of different data types. The sub-index 0 data type is UNSIGNED8, so it is not a RECORD data.

#### Data type

Refer to CANopen DS301.



## 12.4.2 List of objects

### OD 1XXXh communication object group

Index	Object code	Name	Data type	Access
1000h	VAR	Device type	UNSIGNED32	RO
1001h	VAR	Error register	UNSIGNED8	RO
1003h	ARRAY	Pre-defined error field	UNSIGNED32	RW
1005h	VAR	COB-ID SYNC message	UNSIGNED32	RO
1006h	VAR	Communication cycle period	UNSIGNED32	RW
100Ch	VAR	Guard time	UNSIGNED16	RW
100Dh	VAR	Life time factor	UNSIGNED8	RW
1010h	ARRAY	Store parameters	UNSIGNED32	RW
1011h	ARRAY	Restore parameters	UNSIGNED32	RW
1014h	VAR	COB-ID emergency message	UNSIGNED32	RO
1016h	ARRAY	Consumer heartbeat time	UNSIGNED32	RW
1017h	VAR	Producer heartbeat time	UNSIGNED16	RW
1018h	RECORD	Identity object	UNSIGNED32	RO
1029h	ARRAY	Error behavior	UNSIGNED8	RW
1200h	RECORD	Server SDO parameter	SDO parameter	RO
1400h - 1403h	RECORD	Receive PDO communication parameter	UNSIGNED16/32	RW
1600h - 1603h	RECORD	Receive PDO mapping parameter	UNSIGNED32	RW
1800h - 1803h	RECORD	Transmit PDO communication parameter	UNSIGNED16/32	RW
1A00h - 1A03h	RECORD	Transmit PDO mapping parameter	UNSIGNED32	RW

Note: only 1001h can be mapped to PDO.

### OD 2XXXh servo parameter group

Index	Object code	Name	Data type	Access	Mappable
2XXXh	VAR	Parameter Mapping	INTEGER16/32	RW	Y

### OD 6XXXh communication object group

Index	Object code	Name	Data type	Access	Mappable
603Fh	VAR	Error code	UNSIGNED16	RO	Y
6040h	VAR	Controlword	UNSIGNED16	RW	Y
6041h	VAR	Statusword	UNSIGNED16	RO	Y
605Bh	VAR	Shutdown option code	INTEGER16	RW	Y
6060h	VAR	Modes of operation	INTEGER8	RW	Y
6061h	VAR	Modes of operation display	INTEGER8	RO	Y
6062h	VAR	Position demand value [PUU]	INTEGER32	RO	Y
6063h	VAR	Position actual internal value [Pulse]	INTEGER32	RO	Y
6064h	VAR	Position actual value [PUU]	INTEGER32	RO	Y
6065h	VAR	Following error window	UNSIGNED32	RW	Y
6067h	VAR	Position window	UNSIGNED32	RW	Y
6068h	VAR	Position window time	UNSIGNED16	RW	Y
606Bh	VAR	Velocity demand value	INTEGER32	RO	Y
606Ch	VAR	Velocity actual value	INTEGER32	RO	Y
606Dh	VAR	Velocity window	UNSIGNED16	RW	Y
606Eh	VAR	Velocity window time	UNSIGNED16	RW	Y

Index	Object code	Name	Data type	Access	Mappable
606Fh	VAR	Velocity threshold	UNSIGNED16	RW	Y
6071h	VAR	Target torque	INTEGER16	RW	Y
6072h	VAR	Max torque	UNSIGNED16	RW	Y
6074h	VAR	Torque demand value	INTEGER16	RO	Y
6075h	VAR	Motor rated current	UNSIGNED32	RO	Y
6076h	VAR	Motor rated torque	UNSIGNED32	RO	Y
6077h	VAR	Torque actual value	INTEGER16	RO	Y
6078h	VAR	Current actual value	INTEGER16	RO	Y
607Ah	VAR	Target position	INTEGER32	RW	Y
607Ch	VAR	Home offset	INTEGER32	RW	Y
607Dh	ARRAY	Software position limit	INTEGER32	RW	Y
607Fh	VAR	Max profile velocity	UNSIGNED32	RW	Y
6080h	VAR	Max motor speed	UNSIGNED32	RW	Y
6081h	VAR	Profile velocity	UNSIGNED32	RW	Y
6083h	VAR	Profile acceleration	UNSIGNED32	RW	Y
6084h	VAR	Profile deceleration	UNSIGNED32	RW	Y
6085h	VAR	Quick stop deceleration	UNSIGNED32	RW	Y
6087h	VAR	Torque slope	UNSIGNED32	RW	Y
6093h	ARRAY	Position factor	UNSIGNED32	RW	Y
6098h	VAR	Homing method	INTEGER8	RW	Y
6099h	ARRAY	Homing speeds	UNSIGNED32	RW	Y
609Ah	VAR	Homing acceleration	UNSIGNED32	RW	Y
60C0h	VAR	Interpolation sub mode select	INTEGER16	RW	Y
60C1h	ARRAY	Interpolation data record	INTEGER32	RW	Y
60C2h	RECORD	Interpolation time period	UNSIGNED8	RW	Y
60C5h	VAR	Max acceleration	UNSIGNED32	RW	Y
60C6h	VAR	Max deceleration	UNSIGNED32	RW	Y
60F4h	VAR	Following error actual value	INTEGER32	RO	Y
60FCh	VAR	Position demand value	INTEGER32	RO	Y
60FDh	VAR	Digital inputs	UNSIGNED32	RO	Y
60FEh	ARRAY	Digital outputs	UNSIGNED32	RW	Y
60FFh	VAR	Target velocity	INTEGER32	RW	Y
6502h	VAR	Supported drive modes	UNSIGNED32	RO	Y

## 12.4.3 Details of objects

### 12.4.3.1 OD 1XXXh communication object group

# 12

Object 1000h: Device type

Index	1000h
Name	Device type
Object code	VAR
Data type	UNSIGNED32
Access	RO
PDO mapping	No
Setting range	UNSIGNED32

Format of this object: (High word h) DCBA; (Low word L) UZYX

A	Bit 16 - Bit 31 Model type	X	Bit 0 - Bit 15 Device profile number
B		Y	
C		Z	
D		U	

Definitions are as follows:

- UZYX: device profile number (servo drive: 0192)
- DCBA: model type

DCBA	Model type
0402	A2
0602	M
0702	A3
0B02	B3

Object 1001h: Error register

Index	1001h
Name	Error register
Object code	VAR
Data type	UNSIGNED8
Access	RO
PDO mapping	Yes
Setting range	UNSIGNED8
Default	0

Object function:

The bits and corresponding functions are as follows:

Bit	7	6	5	4	3	2	1	0
-----	---	---	---	---	---	---	---	---

Bit	Function
Bit 0	Generic error
Bit 1	Current
Bit 2	Voltage
Bit 3	Temperature
Bit 4	Communication error
Bit 5 - Bit 7	Reserved

12

Object 1003h: Pre-defined error field

Index	1003h
Name	Pre-defined error field
Object code	ARRAY
Data type	UNSIGNED32
Access	RW
PDO mapping	No

Sub-index	0
Description	Number of errors
Data type	UNSIGNED8
Access	RW
PDO mapping	No
Setting range	0 - 5
Default	0

Sub-index	1 - 5
Description	Standard error field
Data type	UNSIGNED32
Access	RO
PDO mapping	No
Setting range	UNSIGNED32
Default	0

# 12

Format of this object: (High word h) DCBA; (Low word L) UZYX

A	Bit 16 - Bit 31 Delta servo alarm	X	Bit 0 - Bit 15 Error code
B		Y	
C		Z	
D		U	

Definitions are as follows:

- UZYX: error code. Refer to the error code definition in DS402.
- DCBA: Delta servo alarm. Refer to Chapter 14 Troubleshooting.

Example:

When you operate the servo, if the encoder cable is not correctly connected, the servo drive panel displays AL011 and the error code is stored in the 1003h array. The display is as follows:

Byte:	High word	Low word
	Delta servo alarm (UINT16)	Error code (UINT16)
	0x0011	0x7305

AL011 is defined as “CN2 communication failed” according to the Delta servo alarm.

Error code: 0x7305 is defined as “Incremental sensor 1 fault” according to DS402.

Object 1005h: COB-ID SYNC message

Index	1005h
Name	COB-ID SYNC message
Object code	VAR
Data type	UNSIGNED32
Access	RO
PDO mapping	No
Setting range	UNSIGNED32
Default	80h

Object function:

This object is read-only and cannot be set.

Bit	31	30	29	28	27	26	25	24	23	22	21	20	19	18	17	16
-----	----	----	----	----	----	----	----	----	----	----	----	----	----	----	----	----

Bit	15	14	13	12	11	10	9	8	7	6	5	4	3	2	1	0
-----	----	----	----	----	----	----	---	---	---	---	---	---	---	---	---	---

Bit	Function	Description
Bit 0 - Bit 10	SYNC-COB-ID = 0x80	-
Bit 11 - Bit 31	Reserved	-

## Object 1006h: Communication cycle period

Index	1006h
Name	Communication cycle period
Object code	VAR
Data type	UNSIGNED32
Access	RW
PDO mapping	No
Setting range	UNSIGNED32
Default	0
Unit	μs

## Object function:

This object is to set the communication cycle (unit: μs). The communication cycle is the interval between two SYNCs. If you are not using SYNC, set this object to 0.

## Object 100Ch: Guard time

Index	100Ch
Name	Guard time
Object code	VAR
Data type	UNSIGNED16
Access	RW
PDO mapping	No
Setting range	UNSIGNED16
Default	0
Unit	ms

## Object function:

OD 100Ch and OD 100Dh work for the Life Guarding Protocol. OD 100Ch is the guard time in milliseconds and OD 100Dh is the multiplying factor. Therefore, OD 100Ch multiplied by OD 100Dh gives the life time for the Life Guarding Protocol. If the guard time (OD 100Ch) is set to 0, then the Life Guarding Protocol is invalid.

Example: if OD 100Ch = 5 ms and OD 100Dh = 10, then the life time is 50 ms.

## 12

## Object 100Dh: Life time factor

Index	100Dh
Name	Life time factor
Object code	VAR
Data type	UNSIGNED8
Access	RW
PDO mapping	No
Setting range	UNSIGNED8
Default	0

## Object function:

OD 100Ch and OD 100Dh work for the Life Guarding Protocol. OD 100Ch is the guard time in milliseconds and OD 100Dh is the multiplying factor. Therefore, OD 100Ch multiplied by OD 100Dh gives the life time for the Life Guarding Protocol. If the guard time (OD 100Ch) is set to 0, then the Life Guarding Protocol is invalid.

Example: if OD 100Ch = 5 ms and OD 100Dh = 10, then the life time is 50 ms.

## Object 1010h: Store parameters

Index	1010h
Name	Store parameters
Object code	ARRAY
Data type	UNSIGNED32
Access	RW
PDO mapping	No

Sub-index	0
Description	Number of sub-index
Data type	UNSIGNED8
Access	RO
PDO mapping	No
Setting range	UNSIGNED8
Default	1

Sub-index	1
Description	Store communication parameters
Data type	UNSIGNED32
Access	RW
PDO mapping	No
Setting range	No
Default	1

Object function:

You can only write 0x65766173 (save) to sub-index 1, writing all current OD values to the EEPROM.

Object 1011h: Restore parameters

Index	1011h
Name	Restore parameters
Object code	ARRAY
Data type	UNSIGNED32
Access	RW
PDO mapping	No

Sub-index	0
Description	Number of sub-index
Data type	UNSIGNED8
Access	RO
PDO mapping	No
Setting range	UNSIGNED8
Default	1

Sub-index	1
Description	Restore communication parameters
Data type	UNSIGNED32
Access	RW
PDO mapping	No
Setting range	No
Default	1

Object function:

You can only write 0x64616F6C (load) to sub-index 1, resetting all OD parameters to their default values.



## 12

Object 1014h: COB-ID emergency message

Index	1014h
Name	COB-ID emergency message
Object code	VAR
Data type	UNSIGNED32
Access	RO
PDO mapping	No
Setting range	UNSIGNED32
Default	80h + Node-ID

Object function:

Bit	31	30	29	28	27	26	25	24	23	22	21	20	19	18	17	16
Bit	15	14	13	12	11	10	9	8	7	6	5	4	3	2	1	0

Bit	Function	Description
Bit 0 - Bit 10	COB-ID	80h + Node-ID. The data size is 11-bit.
Bit 11 - Bit 30	Reserved	-
Bit 31	Emergency (EMCY) function	0: the emergency (EMCY) function is enabled (servo drive sends the EMCY command). 1: the emergency (EMCY) function is disabled (servo drive does not send the EMCY command).

The COB-ID setting format is as follows:

Communication object	Function code Bit <span style="border: 1px solid black; padding: 0 2px;">10</span> <span style="border: 1px solid black; padding: 0 2px;">9</span> <span style="border: 1px solid black; padding: 0 2px;">8</span> <span style="border: 1px solid black; padding: 0 2px;">7</span>	Node ID Bit <span style="border: 1px solid black; padding: 0 2px;">6</span> <span style="border: 1px solid black; padding: 0 2px;">5</span> <span style="border: 1px solid black; padding: 0 2px;">4</span> <span style="border: 1px solid black; padding: 0 2px;">3</span> <span style="border: 1px solid black; padding: 0 2px;">2</span> <span style="border: 1px solid black; padding: 0 2px;">1</span> <span style="border: 1px solid black; padding: 0 2px;">0</span>	COB-ID DEC (HEX)
EMCY object	0001	1	129 (81h)
		2	130 (82h)
		...	...
		127	255 (FFh)

## Object 1016h: Consumer heartbeat time

Index	1016h
Name	Consumer heartbeat time
Object code	ARRAY
Data type	UNSIGNED32
Access	RW
PDO mapping	No

Sub-index	0
Description	Number of sub-index
Data type	UNSIGNED8
Access	RO
PDO mapping	No
Setting range	1
Default	1

Sub-index	1
Description	Consumer heartbeat time
Data type	UNSIGNED32
Access	RW
PDO mapping	No
Setting range	UNSIGNED32
Default	0

## Object function:

Bit	31	30	29	28	27	26	25	24	23	22	21	20	19	18	17	16
-----	----	----	----	----	----	----	----	----	----	----	----	----	----	----	----	----

Bit	15	14	13	12	11	10	9	8	7	6	5	4	3	2	1	0
-----	----	----	----	----	----	----	---	---	---	---	---	---	---	---	---	---

Bit	Function	Description
Bit 0 - Bit 15	Heartbeat time	UNSIGNED8; unit: ms
Bit 16 - Bit 23	Node-ID	UNSIGNED8
Bit 24 - Bit 31	Reserved	-

Consumer heartbeat time is defined as the time the servo drive expects to receive a heartbeat. When the heartbeat consumer does not receive the heartbeat signal within the receiving time, it triggers the heartbeat event, meaning AL180 is triggered. The consumer heartbeat time must be greater than the producer heartbeat time. Since there are delays and other uncontrollable external factors in transmitting the heartbeat message, you must retain a tolerance time for the transmission.

## Object 1017h: Producer heartbeat time

Index	1017h
Name	Producer heartbeat time
Object code	VAR
Data type	UNSIGNED16
Access	RW
PDO mapping	No
Setting range	UNSIGNED16
Default	0

## Object function:

Producer heartbeat time is defined as the cycle time of the heartbeat. When this value is set to 0, this function is invalid.

## Object 1018h: Identity object

Index	1018h
Name	Identity object
Object code	RECORD
Data type	Identity
Access	RO
PDO mapping	No

Sub-index	0
Description	Number of sub-index
Data type	UNSIGNED8
Access	RO
PDO mapping	No
Setting range	3
Default	3

Sub-index	1
Description	Vendor ID
Data type	UNSIGNED32
Access	RO
PDO mapping	No
Setting range	UNSIGNED32
Default	1DDh

Sub-index	2
Description	Product code
Data type	UNSIGNED32
Access	RO
PDO mapping	No
Setting range	UNSIGNED32
Default	6000h: A2 series 6010h: A3 series 6030h: M series 6080h: B3 series

Sub-index	3
Description	Version
Data type	UNSIGNED32
Access	RO
PDO mapping	No
Setting range	UNSIGNED32
Default	N/A

Object function:

This object includes the servo drive information.

Object 1029h: Error behavior

Index	1029h
Name	Error behavior
Object code	ARRAY
Data type	UNSIGNED8
Access	RW
PDO mapping	No

Sub-index	0
Description	Number of error types
Data type	UNSIGNED8
Access	RO
PDO mapping	No
Setting range	1
Default	1

## 12

Sub-index	1
Description	Communication error
Data type	UNSIGNED8
Access	RW
PDO mapping	No
Setting range	UNSIGNED8
Default	0

Object function:

Generally, when the servo drive detects a serious fault in the Operational state, the state is automatically switched to the Pre-Operational state. Use this object setting to switch the state to the Pre-Operational state, keep the original state, or switch to the Stopped state.

OD 1029h sub1 setting	Switch the state to
0	Pre-Operational (only if it is currently in the Operational state)
1	Keep the original state
2	Stopped

Object 1200h: Server SDO parameter

Index	1200h
Name	Server SDO parameter
Object code	RECORD
Data type	SDO parameter
Access	RO
PDO mapping	No

Sub-index	0
Description	Number of sub-index
Data type	UNSIGNED8
Access	RO
PDO mapping	No
Setting range	2
Default	2

Sub-index	1
Description	Controller sends to servo drive COB-ID Client->Server (rx)
Data type	UNSIGNED32
Access	RO
PDO mapping	No
Setting range	UNSIGNED32
Default	Index 1200h: 600h + Node-ID

Sub-index	2
Description	Servo drive returns to controller COB-ID Server->Client (tx)
Data type	UNSIGNED32
Access	RO
PDO mapping	No
Setting range	UNSIGNED32
Default	Index 1200h: 580h + Node-ID

Object function:

This object is read-only and cannot be set. Read the station number for transmitting and receiving the SDO with this object.

Example:

If the servo drive station number for receiving is 10:

600h + Node-ID: Ah = 600h + Ah = 60Ah → OD 1200h sub1 reads 60Ah.

If the servo drive station number for transmitting is 10:

580h + Node-ID: Ah = 580h + Ah = 58Ah → OD 1200h sub2 reads 58Ah.

## 12

Objects 1400h - 1403h: Receive PDO communication parameter

Index	1400h, 1401h, 1402h, 1403h
Name	Receive PDO communication parameter
Object code	RECORD
Data type	PDO CommPar
Access	RW

Sub-index	0
Description	Number of sub-index
Data type	UNSIGNED8
Access	RO
PDO mapping	No
Setting range	5
Default	5

Sub-index	1
Description	COB-ID used by PDO
Data type	UNSIGNED32
Access	RW
PDO mapping	No
Setting range	UNSIGNED32
Default	Node-ID: 0

Object function:

Bit	31	30	29	28	27	26	25	24	23	22	21	20	19	18	17	16
Bit	15	14	13	12	11	10	9	8	7	6	5	4	3	2	1	0

Bit	Function	Description
Bit 0 - Bit 10	COB-ID	The data size is 11-bit.
Bit 11 - Bit 30	Reserved	-
Bit 31	PDO function switch	0: enable PDO function. 1: disable PDO function. Enable / disable the PDO function to determine if the PDO is used in the Operational state.

The COB-ID setting format is as follows:

Communication object	Object index	COB-ID DEC (HEX)
RxPDO1	1400h	512 (200h) + Node-ID
RxPDO2	1401h	768 (300h) + Node-ID
RxPDO3	1402h	1024 (400h) + Node-ID
RxPDO4	1403h	1280 (500h) + Node-ID

Sub-index	2
Description	Transmission type
Data type	UNSIGNED8
Access	RW
PDO mapping	No
Setting range	UNSIGNED8
Default	0

Object function:

The transmission type setting is as follows.

Setting value	Transmission type				
	Cyclic	Acyclic	Synchronous	Asynchronous	RTR only
00h (0)		V	V		
01h - F0h (1 - 240)	V		V		
F1h - FBh (241 - 251)	Reserved				
FCh (252)			V		V
FDh (253)				V	V
FEh (254)				V	
FFh (255)				V	

Sub-index	3
Description	Inhibit time (not used for RxPDO)
Data type	UNSIGNED16
Access	RW
PDO mapping	No
Setting range	UNSIGNED16
Default	0

Sub-index	4
Description	Compatibility entry
Data type	UNSIGNED8
Access	RW
PDO mapping	No
Setting range	UNSIGNED8
Default	0



## 12

Sub-index	5
Description	Event timer (not used for RxPDO)
Data type	UNSIGNED16
Access	RW
PDO mapping	No
Setting range	UNSIGNED16
Default	0

## Objects 1600h - 1603h: Receive PDO mapping parameter

Index	1600h, 1601h, 1602h, 1603h
Name	Receive PDO mapping parameter
Object code	RECORD
Data type	PDO mapping
Access	RW
Note	The total length of objects in a group of PDO cannot exceed 64 bits.

Sub-index	0
Description	Number of PDO mappings
Data type	UNSIGNED8
Access	RW
PDO mapping	No
Setting range	0: disable 1 - 8: set the number of PDO mapping and enable the function
Default	0

Sub-index	1 - 8
Description	Specify the 1 <sup>st</sup> (to 8 <sup>th</sup> ) object and its content to be mapped
Data type	UNSIGNED32
Access	RW
PDO mapping	No
Setting range	UNSIGNED32
Default	0

The format of this object is as follows:

Bit	31	30	29	28	27	26	25	24	23	22	21	20	19	18	17	16
Bit	15	14	13	12	11	10	9	8	7	6	5	4	3	2	1	0

Bit	Function
Bit 0 - Bit 7	Object data length
Bit 8 - Bit 15	Object sub-index
Bit 16 - Bit 31	Object index

12

Example:

To set the three PDOs, OD 6040h, OD 607Ah, and OD 6060h, in the first group of PDO, the setting is as follows:

Mapping parameter setting for RxPDO	Data			Description
OD 1600h sub0	3			Set 3 PDO mappings.
OD 1600h sub1	6040h	00h	10h	Mapping Controlword (6040h); data length is 16-bit.
OD 1600h sub2	607Ah	00h	20h	Mapping target position (607Ah); data length is 32-bit.
OD 1600h sub3	6060h	00h	08h	Mapping mode (6060h); data length is 8-bit.
Note	The total length is 38h (56-bit) which meets the specification of less than 64-bit.			

Objects 1800h - 1803h: Transmit PDO communication parameter

Index	1800h, 1801h, 1802h, 1803h
Name	Transmit PDO communication parameter
Object code	RECORD
Data type	PDO CommPar
Access	RW

Sub-index	0
Description	Largest sub-index supported
Data type	UNSIGNED8
Access	RO
PDO mapping	No
Setting range	5
Default	5

## 12

Sub-index	1
Description	COB-ID used by PDO
Data type	UNSIGNED32
Access	RW
PDO mapping	No
Setting range	UNSIGNED32
Default	Default Node-ID: 0 Index 1800h: 180h + Node-ID Index 1801h: 280h + Node-ID Index 1802h: 380h + Node-ID Index 1803h: 480h + Node-ID

Object function:

Bit	31	30	29	28	27	26	25	24	23	22	21	20	19	18	17	16
Bit	15	14	13	12	11	10	9	8	7	6	5	4	3	2	1	0

Bit	Function	Description
Bit 0 - Bit 10	COB-ID	The data size is 11-bit.
Bit 11 - Bit 30	Reserved	-
Bit 31	PDO function switch	0: enable PDO function. 1: disable PDO function. Enable / disable the PDO function to determine if the PDO is used in the Operational state.

Sub-index	2
Description	Transmission type
Data type	UNSIGNED8
Access	RW
PDO mapping	No
Setting range	UNSIGNED8
Default	0

Object function:

The transmission type setting is as follows:

Setting value	Transmission type				
	Cyclic	Acyclic	Synchronous	Asynchronous	RTR only
00h (0)		V	V		
01h - F0h (1 - 240)	V		V		
F1h - FBh (241 - 251)	Reserved				
FCh (252)			V		V
FDh (253)				V	V
FEh (254)				V	
FFh (255)				V	

12

Sub-index	3
Description	Inhibit time
Data type	UNSIGNED16
Access	RW
PDO mapping	No
Setting range	UNSIGNED16
Default	0

Sub-index	4
Description	Reserved
Data type	UNSIGNED8
Access	RW
PDO mapping	No
Setting range	UNSIGNED8
Default	0

Sub-index	5
Description	Event timer
Data type	UNSIGNED16
Access	RW
PDO mapping	No
Setting range	0: not in use UNSIGNED16
Default	0

## 12

Objects 1A00h - 1A03h: Transmit PDO mapping parameter

Index	1A00h, 1A01h, 1A02h, 1A03h
Name	Transmit PDO mapping parameter
Object code	RECORD
Data type	PDO mapping
Access	RW
Note	The total length of objects in a group of PDO cannot exceed 64 bits.

Sub-index	0
Description	Number of PDO mappings
Data type	UNSIGNED8
Access	RW
PDO mapping	No
Setting range	0: disable 1 - 8: set the number of PDO mapping and enable the function
Default	0

Sub-index	1 - 8
Description	Specify the 1 <sup>st</sup> (to 8 <sup>th</sup> ) object and its content to be mapped
Data type	UNSIGNED32
Access	RW
PDO mapping	No
Setting range	UNSIGNED32
Default	0

Format of this object: (High word h) DCBA; (Low word L) UZYX

DCBA	Bit 16 - Bit 31 Object index	YX	Bit 0 - Bit 7 Object data length
		UZ	Bit 8 - Bit 15 Object sub-index

### 12.4.3.2 OD 2XXXh servo parameter group

Object 2XXXh: Parameter Mapping

Index	2XXXh
Name	Parameter Mapping
Object code	VAR
Data type	INTEGER16 / INTEGER32
Access	RW
PDO mapping	Yes
Setting range	INTEGER16 / INTEGER32
Default	N/A

# 12

Object function:

Access the servo parameters with the OD 2XXXh group. The parameter number and index are converted as follows:

<b>Pa.bcd &lt;= = &gt; 2aBCh</b> <b>'BC' is hexadecimal format of 'bcd'</b>
--

Read the index first to get the information of the parameter length, and then use the SDO or PDO to change the data.

Example 1:

Object 2300h: Node-ID [P3.000]

Index	2300h
Name	Node-ID
Object code	VAR
Data type	INTEGER16
Access	RW
PDO mapping	Yes
Setting range	INTEGER16
Default	7F

## 12

Example 2:

Object 212Ch: Electronic Gear [P1.044]

Index	212Ch
Name	Electronic Gear
Object code	VAR
Data type	INTEGER32
Access	RW
PDO mapping	Yes
Setting range	INTEGER32
Default	1

### 12.4.3.3 OD 6XXXh communication object group

Object 603Fh: Error code (CANopen-defined)

Index	603Fh
Name	Error code
Object code	VAR
Data type	UNSIGNED16
Access	RO
PDO mapping	Yes
Setting range	UNSIGNED16
Default	0

Object 6040h: Controlword

Index	6040h
Name	Controlword
Object code	VAR
Data type	UNSIGNED16
Access	RW
PDO mapping	Yes
Setting range	UNSIGNED16
Default	0x0004

Object function:

The Controlword contains many functions, such as Servo On, command triggering, fault reset, and quick stop.

The state machine architecture is as follows:

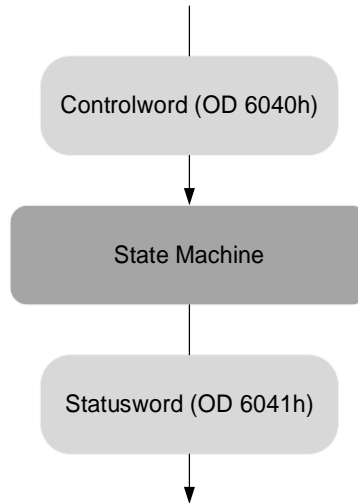

Bit	15	14	13	12	11	10	9	8	7	6	5	4	3	2	1	0
-----	----	----	----	----	----	----	---	---	---	---	---	---	---	---	---	---

Bit	Function	Description
Bit 0	Switch on	Ready for Servo On.
Bit 1	Enable voltage	-
Bit 2	Quick stop (B contact (NC))	-
Bit 3	Enable operation	Servo On.
Bit 4 - Bit 6	Defined in each operation mode	These bits are individually defined according to the operation mode, as shown in the following table.
Bit 7	Fault reset	-
Bit 8	Halt	-
Bit 9 - Bit 15	Reserved	-

Bits 4 - 6 are individually defined according to the operation mode, as shown in the following table:

Bit	Definition in each operation mode		
	Profile Position mode	Homing mode	Profile Velocity mode Profile Torque mode Interpolated Position mode
Bit 4	Command triggering (rising-edge triggered)	Homing (rising-edge triggered)	-
Bit 5	Function for the command to take immediate effect	-	-
Bit 6	0: absolute position command 1: relative position command	-	-

Note: - indicates the bit is invalid.



## 12

Finite state machine (as shown in the following diagram) defines the behavior of a servo drive system. Each state represents an internal or external behavior. For example, the servo drive can execute point-to-point motion only in the Operation enabled state.

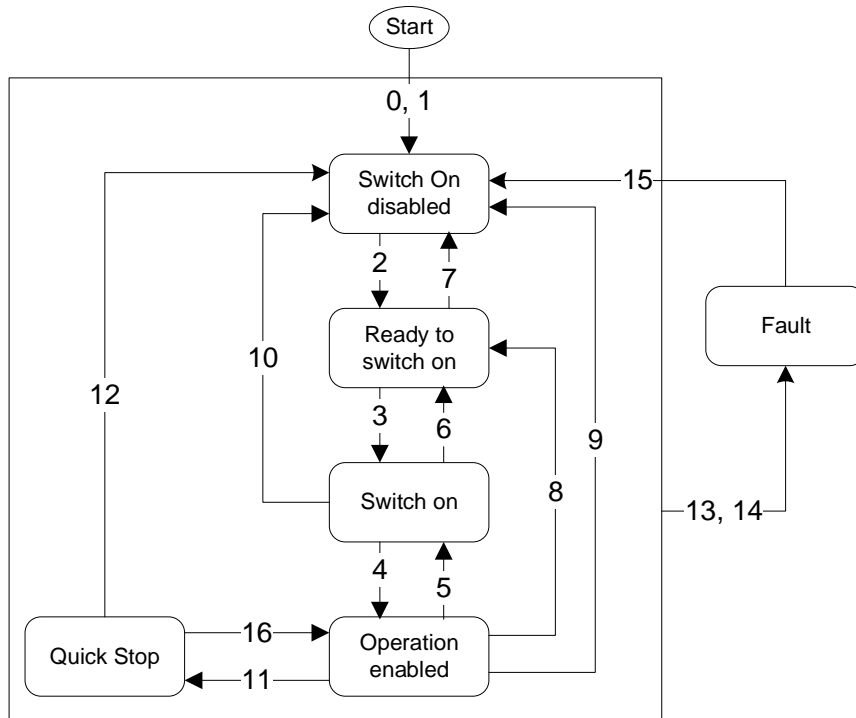

The state transition is defined as follows:

Transition	Event	Action
0, 1	Automatic transition after power-on	Device boot and initialization
2	Shutdown command	N/A
3	Switch on command	Servo is ready for Servo On
4	Enable operation command	Servo switches to Servo On and enters the mode in which the controller is allowed to issue a motion command.
5	Disable operation command	Servo switches to Servo Off
6	Shutdown command	N/A
7	Disable voltage or quick stop command	N/A
8	Shutdown command	Servo switches to Servo Off
9	Disable voltage command	Servo switches to Servo Off
10	Disable voltage or quick stop command	N/A
11	Quick stop command The following two errors belong to this quick stop type: 1. Positive / negative limit switch triggered 2. Quick stop triggered by the Controlword (OD 6040h [Bit 2] = 0)	Quick stop function is enabled. The time setting for deceleration to a stop is different for the two errors. 1. OD 2503h (P5.003) 2. OD 6085h
12	Disable voltage command (OD 6040h = 0000 0110 or OD 6040h [Bit 1] = 0)	Servo switches to Servo Off
13, 14	Alarm occurs	Servo switches to Servo Off
15	Fault reset	N/A
16	Enable operation command; no alarm	Motion operation restart. The restart action is mode-dependent.

State transition can be achieved with the Controlword (OD 6040h). The commands are as follows:

Command	Bit of OD 6040h					Transition
	Bit 7	Bit 3	Bit 2	Bit 1	Bit 0	
Shutdown	0	X	1	1	0	2, 6, 8
Switch on	0	0	1	1	1	3
Switch on + Enable operation	0	1	1	1	1	3 + 4
Disable voltage	0	X	X	0	X	7, 9, 10, 12
Quick stop	0	X	0	1	X	7, 10, 11
Disable operation	0	0	1	1	1	5
Enable operation	0	1	1	1	1	4, 16
Fault reset		X	X	X	X	15

Object 6041h: Statusword

Index	6041h
Name	Statusword
Object code	VAR
Data type	UNSIGNED16
Access	RO
PDO mapping	Yes
Setting range	UNSIGNED16
Default	0

Object function:

The Statusword contains many statuses, such as Servo On, command statuses, fault signal, and quick stop. The state machine architecture is as follows:

Bit	15	14	13	12	11	10	9	8	7	6	5	4	3	2	1	0
-----	----	----	----	----	----	----	---	---	---	---	---	---	---	---	---	---

Bit	Status		Description
Bit 0	Ready to switch on	Ready to be activated	Bit 0 - Bit 6: current status of the servo drive (see the following table for details).
Bit 1	Switched on	Servo ready	
Bit 2	Operation enabled	Servo On	
Bit 3	Fault	Fault signal	
Bit 4	Voltage enabled	Servo is powered on	
Bit 5	Quick stop	Quick stop	
Bit 6	Switch on disabled	Servo disabled	
Bit 7	Warning	Warning signal	When outputting the warning signal, the servo keeps outputting the Servo On signal.
Bit 8	Reserved	-	-
Bit 9	Remote	Remote control	-
Bit 10	Target reached	Target reached	-
Bit 11	Reserved	-	-

## 12

Bit	Status		Description
Bit 12 - Bit 13	-	-	These bits are individually defined according to the operation mode, as shown in the following table.
Bit 14	Positive limit	Positive limit	-
Bit 15	Negative limit	Negative limit	-

Bit 0 - Bit 6: current status of the servo drive.

Bit 6	Bit 5	Bit 4	Bit 3	Bit 2	Bit 1	Bit 0	Description
0	-	-	0	0	0	0	Not ready to switch on.
1	-	-	0	0	0	0	Switch on disabled.
0	1	-	0	0	0	1	Ready to switch on.
0	1	-	0	0	1	1	Switched on.
0	1	-	0	1	1	1	Operation enabled (Servo On).
0	0	-	0	1	1	1	Quick stop active.
0	-	-	1	1	1	1	Fault reaction active.
0	-	-	1	0	0	0	Servo fault (servo switches to Servo Off).

Note: 0 indicates the bit is off, 1 indicates the bit is on, and - indicates the bit is invalid.

Bit 12 - Bit 13: current status of the servo drive.

Bit	Definition in each operation mode				
	Profile Position mode	Homing mode	Interpolated Position mode	Profile Velocity mode	Profile Torque mode
Bit 12	Set-point acknowledge (servo received the command signal)	Homing is complete	Interpolation in operation	Zero speed	-
Bit 13	Following error	Homing error	-	-	-

Note: - indicates the bit is invalid.

Object 605Bh: Shutdown option code

Index	605Bh
Name	Shutdown option code
Object code	VAR
Data type	INTEGER16
Access	RW
PDO mapping	Yes
Setting range	INTEGER16
Default	0

Object function:

Set to 0: when Servo Off, the dynamic brake has no effect, so the motor runs freely and the machine stops only by friction.

Set to -1: when Servo Off, the servo stops with the operation of the dynamic brake.

Note: when P3.012.Z is set to 1, the non-volatile setting for this object is enabled.

## Object 6060h: Modes of operation

Index	6060h
Name	Modes of operation
Object code	VAR
Data type	INTEGER8
Access	RW
PDO mapping	Yes
Setting range	INTEGER8
Default	0

## Object function:

This object sets the mode for operation.

Setting value	Mode
0	Reserved
1	Profile Position mode
2	Reserved
3	Profile Velocity mode
4	Profile Torque mode
5	Reserved
6	Homing mode
7	Interpolated Position mode

## Object 6061h: Modes of operation display

Index	6061h
Name	Modes of operation display
Object code	VAR
Data type	INTEGER8
Access	RO
PDO mapping	Yes
Setting range	INTEGER8
Default	0

## Object function:

This object displays the current operation mode. Refer to the table in OD 6060h.

## 12

## Object 6062h: Position demand value (PUU)

Index	6062h
Name	Position demand value
Object code	VAR
Data type	INTEGER32
Access	RO
PDO mapping	Yes
Setting range	INTEGER32
Default	0
Unit	PUU

## Object function:

This position demand value is the interpolation command calculated by the servo internal interpolator. This command passes through the servo internal filter. For its detailed location, refer to the servo architecture diagram of each mode.

## Object 6063h: Position actual internal value (Pulse)

Index	6063h
Name	Position actual internal value
Object code	VAR
Data type	INTEGER32
Access	RO
PDO mapping	Yes
Setting range	INTEGER32
Default	0
Unit	<p>Pulse (unit for encoder pulse resolution)</p> <p>The ASDA-A2 servo drive generates 1,280,000 pulses per motor revolution.</p> <p>The ASDA-A3 / ASDA-B3 servo drive generates 16,777,216 pulses per motor revolution.</p>

## Object 6064h: Position actual value (PUU)

Index	6064h
Name	Position actual value
Object code	VAR
Data type	INTEGER32
Access	RO
PDO mapping	Yes
Setting range	INTEGER32
Default	0
Unit	PUU

## Object 6065h: Following error window

Index	6065h
Name	Following error window
Object code	VAR
Data type	UNSIGNED32
Access	RW
PDO mapping	Yes
Setting range	UNSIGNED32
Default	50331648
Unit	PUU

## Object function:

When the following error actual value (OD 60F4h) exceeds this setting range, AL009 (Excessive deviation of Position command) is triggered.

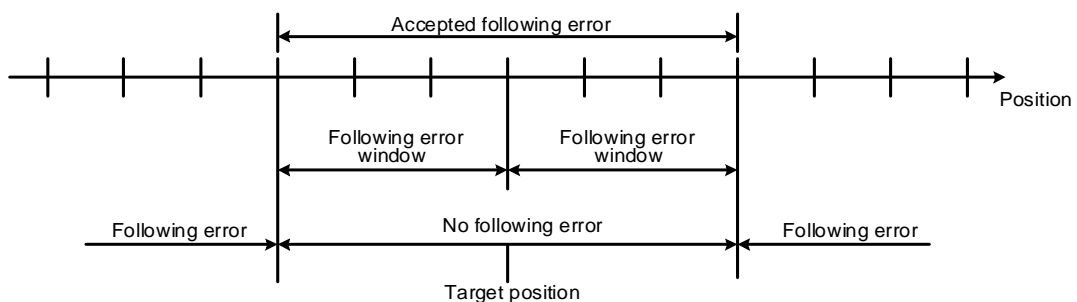

Note: when P3.012.Z is set to 1, the non-volatile setting for this object is enabled.

# 12

Object 6067h: Position window

Index	6067h
Name	Position window
Object code	VAR
Data type	UNSIGNED32
Access	RW
PDO mapping	Yes
Setting range	UNSIGNED32
Default	100
Unit	PUU

Object function:

When the difference (absolute value) between the position command (PP mode: OD 607Ah; IP mode: OD 60C1h) and the position actual value (OD 6064h) is within the range set in OD 6067h (Position window), and the duration of this condition is longer than the time set in OD 6068h (Position window time), OD 6041h [Bit 10] (Target reached) is output.

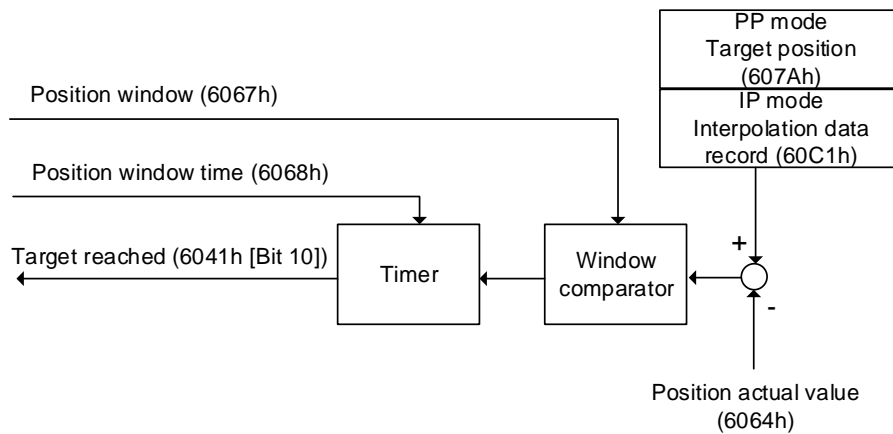
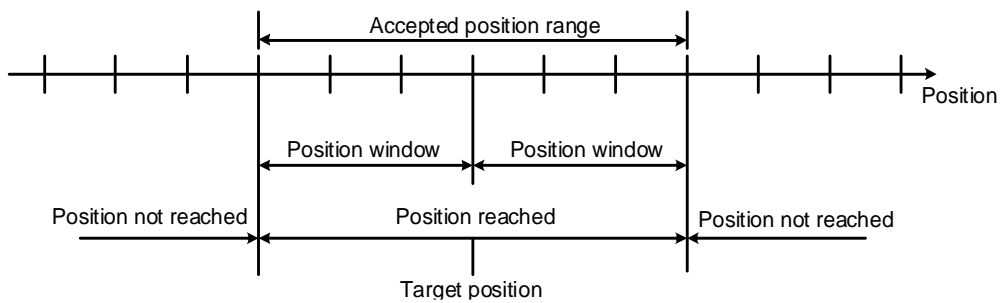

## Object 6068h: Position window time

Index	6068h
Name	Position window time
Object code	VAR
Data type	UNSIGNED16
Access	RW
PDO mapping	Yes
Setting range	UNSIGNED16
Default	0
Unit	ms

## Object function:

When the difference (absolute value) between the position command (PP mode: OD 607Ah; IP mode: OD 60C1h) and the position actual value (OD 6064h) is within the range set in OD 6067h (Position window), and the duration of this condition is longer than the time set in OD 6068h (Position window time), OD 6041h [Bit 10] (Target reached) is output.

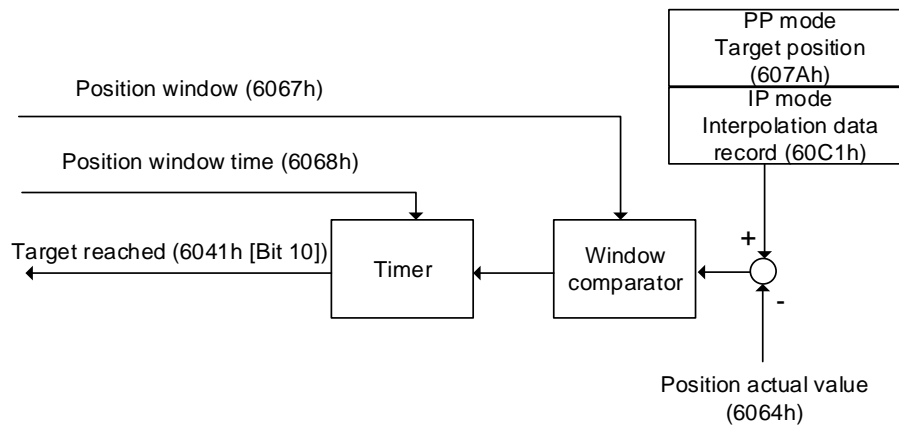

## Object 606Bh: Velocity demand value

Index	606Bh
Name	Velocity demand value
Object code	VAR
Data type	INTEGER32
Access	RO
PDO mapping	Yes
Setting range	INTEGER32
Default	0.1 rpm

## Object function:

The velocity demand value is the command generated by the speed trajectory generator and filtered by the command filter of the drive. This object only works in Profile Velocity mode.



## 12

## Object 606Ch: Velocity actual value

Index	606Ch
Name	Velocity actual value
Object code	VAR
Data type	INTEGER32
Access	RO
PDO mapping	Yes
Setting range	INTEGER32
Default	0.1 rpm

## Object function:

Returns the motor speed at present for monitoring.

## Object 606Dh: Velocity window

Index	606Dh
Name	Velocity window
Object code	VAR
Data type	UNSIGNED16
Access	RW
PDO mapping	Yes
Setting range	0 - 3000
Default	100
Unit	0.1 rpm

## Object function:

The window comparator compares the speed difference with the velocity window (OD 606Dh). When the difference (absolute value) is within the range of the velocity window and the duration of this condition is longer than the time set in the velocity window time (OD 606Eh), OD 6041h [Bit 10] (Target reached) is output. This object only works in Profile Velocity mode.

Note: when P3.012.Z is set to 1, the non-volatile setting for this object is enabled.

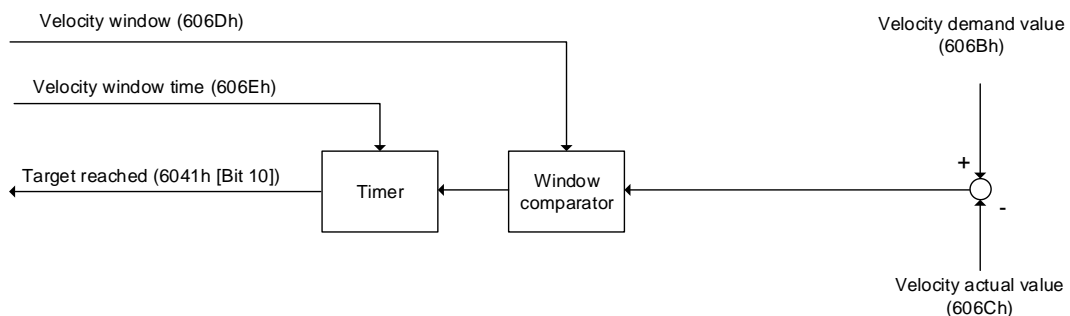

## Object 606Eh: Velocity window time

Index	606Eh
Name	Velocity window time
Object code	VAR
Data type	UNSIGNED16
Access	RW
PDO mapping	Yes
Setting range	UNSIGNED16
Default	0
Unit	ms

## Object function:

Refer to OD 606Dh for the description of the object.

Note: when P3.012.Z is set to 1, the non-volatile setting for this object is enabled.

## Object 606Fh: Velocity threshold

Index	606Fh
Name	Velocity threshold
Object code	VAR
Data type	UNSIGNED16
Access	RW
PDO mapping	Yes
Setting range	0 - 2000
Default	100
Unit	0.1 rpm

## Object function:

This object sets the range for the zero-speed signal output. When the forward or reverse speed (absolute value) of the motor is lower than this set value, the zero-speed signal (OD 6041h [Bit 12]) outputs 1.

Note: when P3.012.Z is set to 1, the non-volatile setting for this object is enabled.

## 12

## Object 6071h: Target torque

Index	6071h
Name	Target torque
Object code	VAR
Data type	INTEGER16
Access	RW
PDO mapping	Yes
Setting range	-3500 to +3500
Default	0
Unit	0.1%

## Object function:

This object sets the target torque (unit: 0.1%) in Profile Torque mode. If OD 6071h = 1000 (100.0%), it corresponds to the motor rated torque.

## Object 6072h: Max torque

Index	6072h
Name	Max torque
Object code	VAR
Data type	UNSIGNED16
Access	RW
PDO mapping	Yes
Setting range	0 - 3500
Default	3500
Unit	0.1%

## Object function:

This object sets the maximum torque (unit: 0.1%) in Profile Torque mode.

## Object 6074h: Torque demand value

Index	6074h
Name	Torque demand value
Object code	VAR
Data type	INTEGER16
Access	RO
PDO mapping	Yes
Setting range	INTEGER16
Default	0
Unit	0.1%

## Object function:

The torque demand value is the command generated by the speed trajectory generator and filtered by the command filter of the drive. This object only works in Profile Torque mode.

## Object 6075h: Motor rated current

Index	6075h
Name	Motor rated current
Object code	VAR
Data type	UNSIGNED32
Access	RO
PDO mapping	Yes
Setting range	UNSIGNED32
Default	0
Unit	mA

## Object function:

This object displays the rated current specified on the motor nameplate.

## 12

## Object 6076h: Motor rated torque

Index	6076h
Name	Motor rated torque
Object code	VAR
Data type	UNSIGNED32
Access	RO
PDO mapping	Yes
Setting range	UNSIGNED32
Default	0
Unit	0.001 N-m

## Object function:

This object displays the rated torque specified on the motor nameplate.

## Object 6077h: Torque actual value

Index	6077h
Name	Torque actual value
Object code	VAR
Data type	INTEGER16
Access	RO
PDO mapping	Yes
Setting range	INTEGER16
Default	0
Unit	0.1%

## Object function:

This object is the motor torque feedback in percentage at present.

## Object 6078h: Current actual value

Index	6078h
Name	Current actual value
Object code	VAR
Data type	INTEGER16
Access	RO
PDO mapping	Yes
Setting range	INTEGER16
Default	0
Unit	0.1%

## Object function:

This object is the motor current feedback in percentage at present.

## Object 607Ah: Target position

Index	607Ah
Name	Target position
Object code	VAR
Data type	INTEGER32
Access	RW
PDO mapping	Yes
Setting range	INTEGER32
Default	0
Unit	PUU

## Object function:

This object only works in Profile Position mode. For more details, refer to Section 12.3.1.

## Object 607Ch: Home offset

Index	607Ch
Name	Home offset
Object code	VAR
Data type	INTEGER32
Access	RW
PDO mapping	Yes
Setting range	INTEGER32
Default	0
Unit	PUU

## Object function:

The origin reference point which the system looks for during the homing procedure is Home position, such as the origin sensor and Z pulse. When the origin reference point is found, the position offset from this point is the user-defined origin (Zero position), and the offset value is Home offset.

Note: when P3.012.Z is set to 1, the non-volatile setting for this object is enabled.

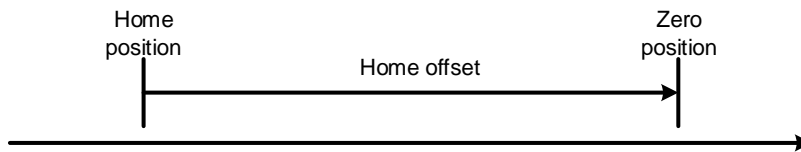

## Object 607Dh: Software position limit

Index	607Dh
Name	Software position limit
Object code	ARRAY
Data type	INTEGER32
Access	RW

Sub-index	0
Description	Number of entries
Data type	UNSIGNED8
Access	RO
PDO mapping	Yes
Setting range	2
Default	2

Sub-index	1
Description	Min position limit
Data type	INTEGER32
Access	RW
PDO mapping	Yes
Setting range	-2147483648 to +2147483647
Default	-2147483648
Unit	PUU

Sub-index	2
Description	Max position limit
Data type	INTEGER32
Access	RW
PDO mapping	Yes
Setting range	-2147483648 to +2147483647
Default	+2147483647
Unit	PUU

Note: when P3.012.Z is set to 1, the non-volatile setting for this object is enabled.

Object 607Fh: Max profile velocity

Index	607Fh
Name	Max profile velocity
Object code	VAR
Data type	UNSIGNED32
Access	RW
PDO mapping	Yes
Setting range	UNSIGNED32
Default	Varies depending on the motor model
Corresponding servo parameter	P1.055 (rpm) * 10
Unit	0.1 rpm

Object function:

The unit of this object is 0.1 rpm, so dividing this object by 10 is equivalent to P1.055 (Maximum speed limit in units of 1 rpm).

Note: when P3.012.Z is set to 1, the non-volatile setting for this object is enabled.



## 12

## Object 6080h: Max motor speed

Index	6080h
Name	Max motor speed
Object code	VAR
Data type	UNSIGNED32
Access	RW
PDO mapping	Yes
Setting range	UNSIGNED32
Default	Varies depending on the motor model
Corresponding servo parameter	P1.055
Unit	rpm

## Object function:

This object is equivalent to P1.055, which is the maximum speed limit of the motor.

Note: when P3.012.Z is set to 1, the non-volatile setting for this object is enabled.

## Object 6081h: Profile velocity

Index	6081h
Name	Profile velocity
Object code	VAR
Data type	UNSIGNED32
Access	RW
PDO mapping	Yes
Setting range	UNSIGNED32
Default	10000
Unit	PUU/s

## Object function:

This object only works in Profile Position mode. For more details, refer to Section 12.3.1.

## Object 6083h: Profile acceleration

Index	6083h
Name	Profile acceleration
Object code	VAR
Data type	UNSIGNED32
Access	RW
PDO mapping	Yes
Setting range	1 - 65500
Default	200
Unit	ms

## Object function:

The time slope set by this object is the time required for the motor to accelerate from 0 rpm to 3,000 rpm. This object only works in Profile Position mode and Profile Velocity mode.

## Object 6084h: Profile deceleration

Index	6084h
Name	Profile deceleration
Object code	VAR
Data type	UNSIGNED32
Access	RW
PDO mapping	Yes
Setting range	1 - 65500
Default	200
Unit	ms

## Object function:

The time slope set by this object is the time required for the motor to decelerate from 3,000 rpm to 0 rpm. This object only works in Profile Position mode and Profile Velocity mode.

## 12

## Object 6085h: Quick stop deceleration

Index	6085h
Name	Quick stop deceleration
Object code	VAR
Data type	UNSIGNED32
Access	RW
PDO mapping	Yes
Setting range	1 - 65500
Default	200
Unit	ms

## Object function:

The time slope set by this object is the time required for the motor to decelerate from 3,000 rpm to 0 rpm.

## Object 6087h: Torque slope

Index	6087h
Name	Torque slope
Object code	VAR
Data type	UNSIGNED32
Access	RW
PDO mapping	Yes
Setting range	0 - 65500
Default	200
Unit	ms

## Object function:

The time slope set by this object is the time required for the motor to change from 0% to 100% of the rated torque.

Note: when P3.012.Z is set to 1, the non-volatile setting for this object is enabled.

## Object 6093h: Position factor

Index	6093h
Name	Position factor
Object code	ARRAY
Data type	UNSIGNED32
Access	RW
PDO mapping	Yes
Corresponding servo parameter	P1.044 and P1.045
Note	Position factor = Numerator / Feed_constant

Sub-index	0
Description	Number of sub-index
Data type	UNSIGNED8
Access	RO
PDO mapping	No
Setting range	2
Default	2

Sub-index	1
Description	E-Gear ratio numerator
Data type	UNSIGNED32
Access	RW
PDO mapping	Yes
Default	1
Corresponding servo parameter	P1.044
Note	For the E-Gear ratio setting, refer to Section 6.2.5.

Sub-index	2
Description	E-Gear ratio denominator
Data type	UNSIGNED32
Access	RW
PDO mapping	Yes
Default	1
Corresponding servo parameter	P1.045
Note	For the E-Gear ratio setting, refer to Section 6.2.5.

Note: when P3.012.Z is set to 1, the non-volatile setting for this object is enabled.

# 12

## Object 6098h: Homing method

Index	6098h
Name	Homing method
Object code	VAR
Data type	INTEGER8
Access	RW
PDO mapping	Yes
Setting range	-4 to 35
Default	0

### Object function:

The homing methods include looking for the Z pulse (Methods 1 - 14, 33, 34, 36, 37), not looking for the Z pulse (Methods 17 - 30), defining the current position as the origin (Method 35), and looking for the hard stop (Methods 36 - 39). Methods 15, 16, 31, and 32 are reserved. To use Methods 1 to 35, set OD 6098h to 1 to 35. To use Methods 36 to 39, set OD 6098h to -1 to -4.

### Method 1: homing on the negative limit switch and Z pulse

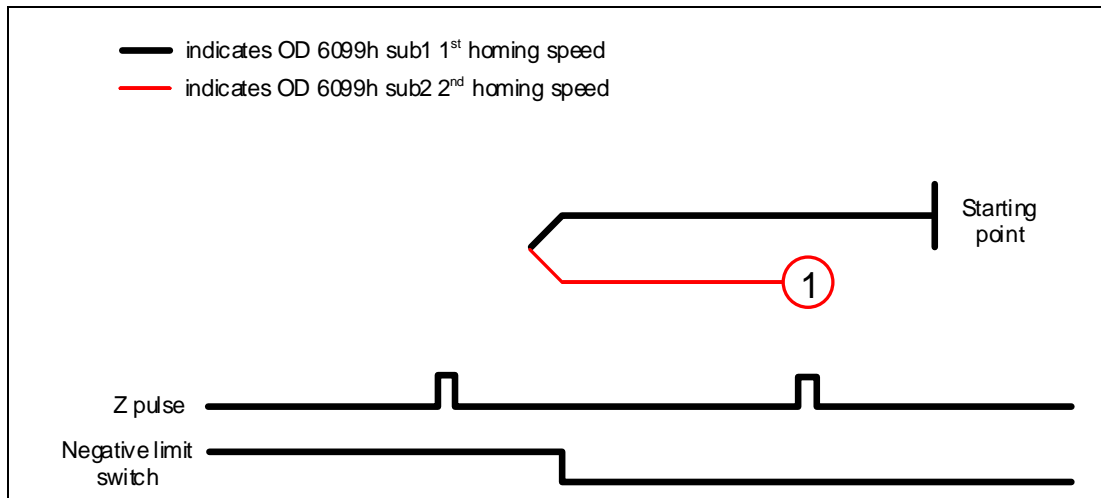

### Method 2: homing on the positive limit switch and Z pulse

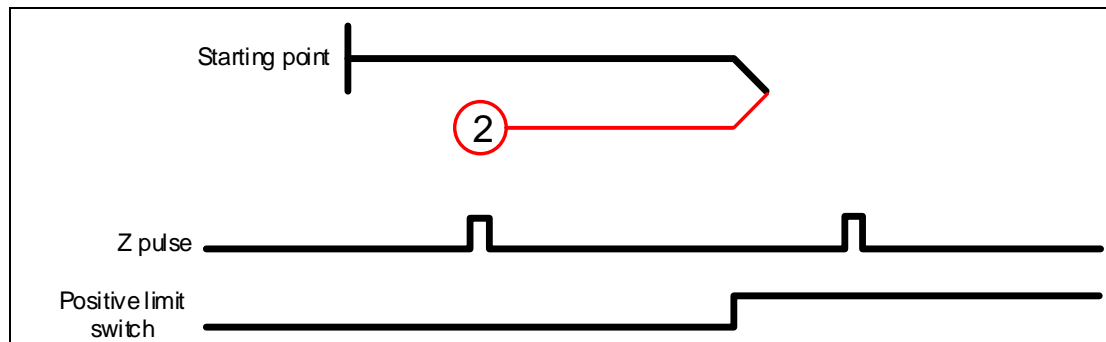

Methods 3 and 4: homing on the home switch and Z pulse

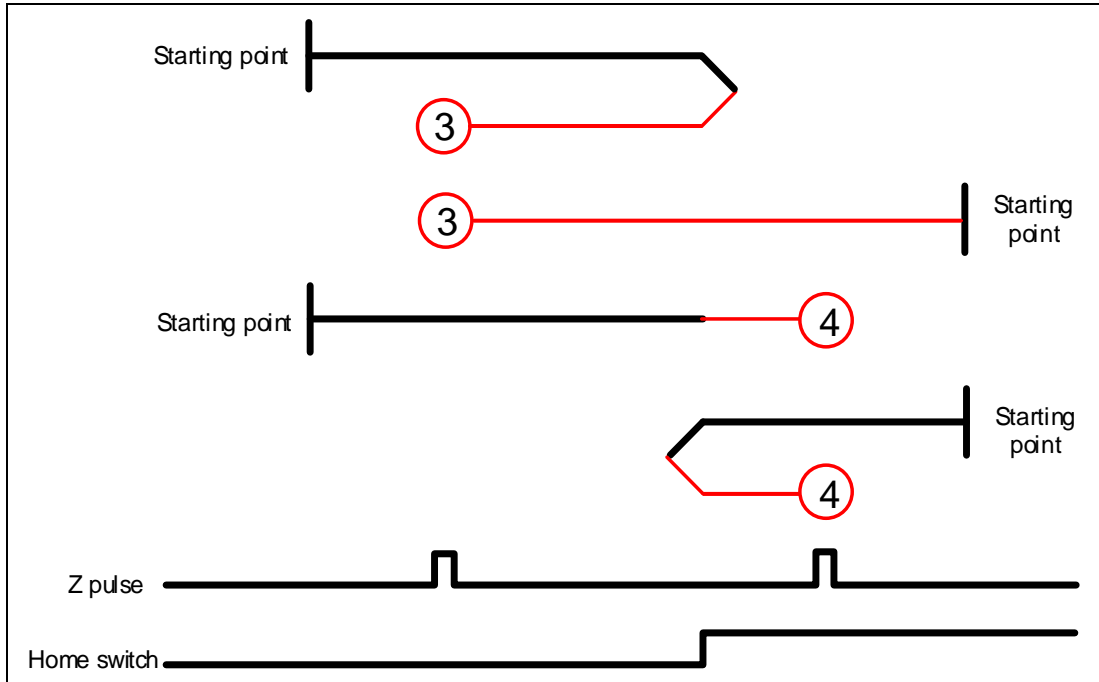

Methods 5 and 6: homing on the home switch and Z pulse

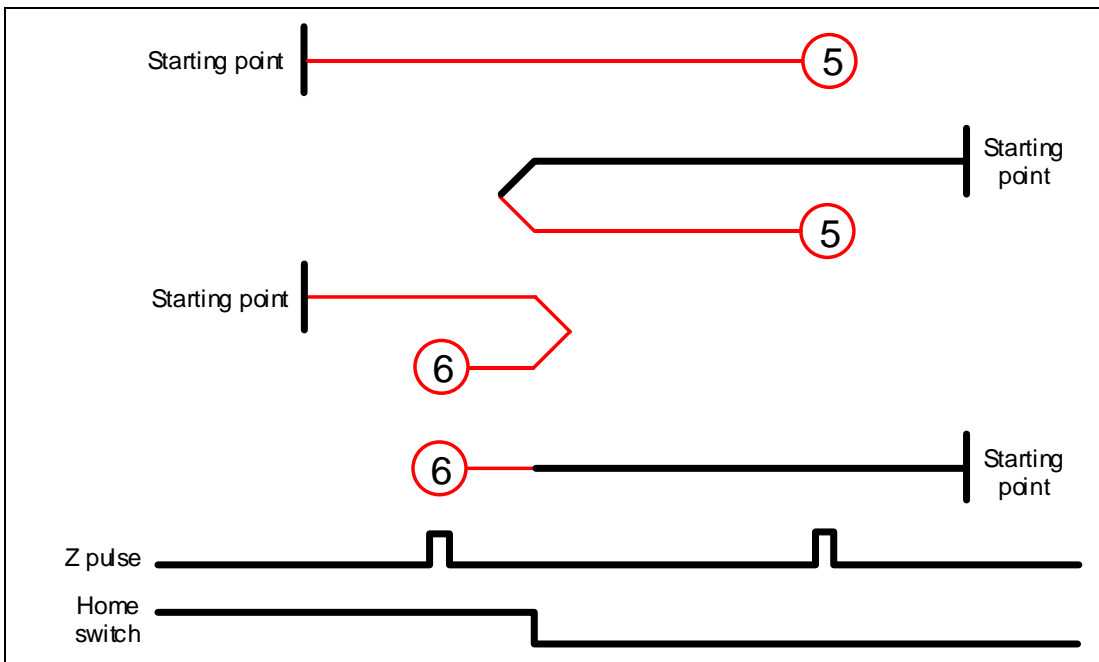

# 12

Method 7: homing on the positive limit switch, home switch, and Z pulse

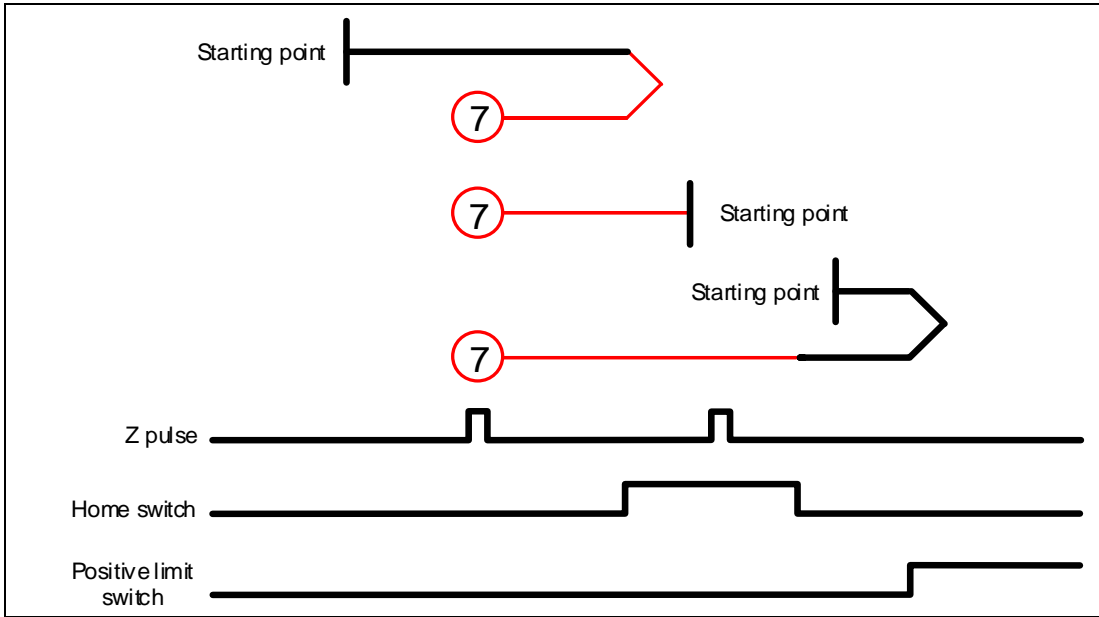

Method 8: homing on the positive limit switch, home switch, and Z pulse

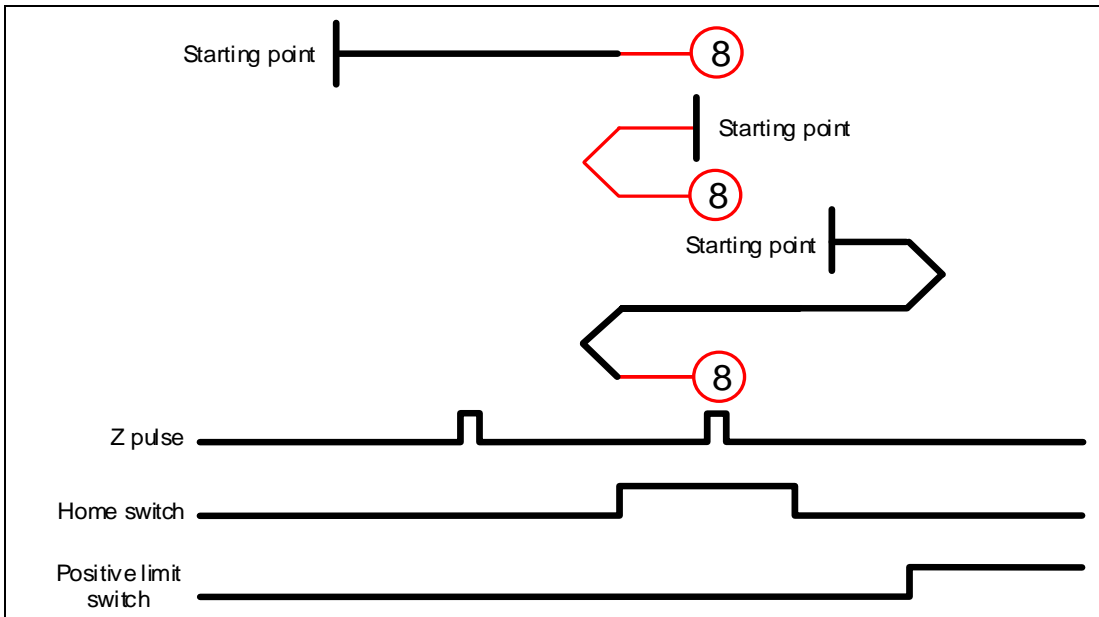

Method 9: homing on the positive limit switch, home switch, and Z pulse

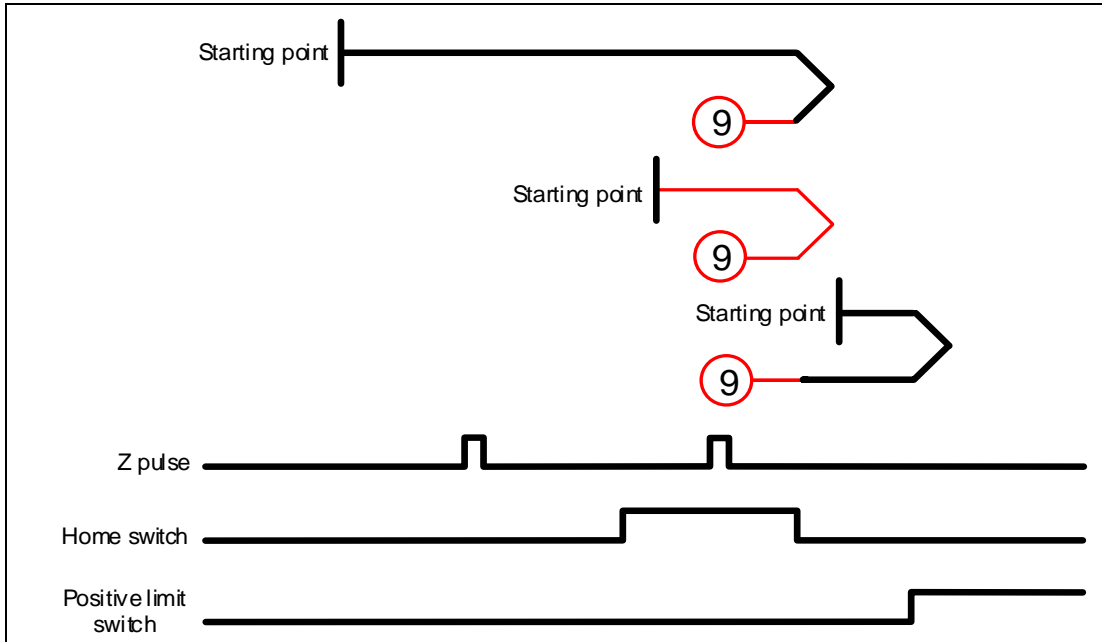

12

Method 10: homing on the positive limit switch, home switch, and Z pulse

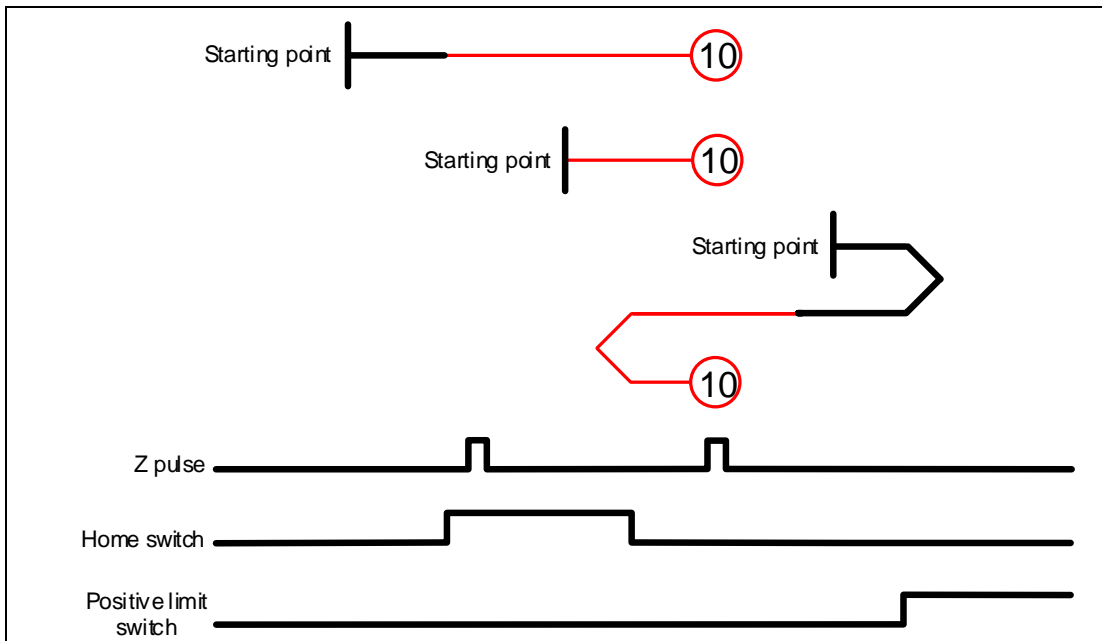



# 12

Method 11: homing on the negative limit switch, home switch, and Z pulse

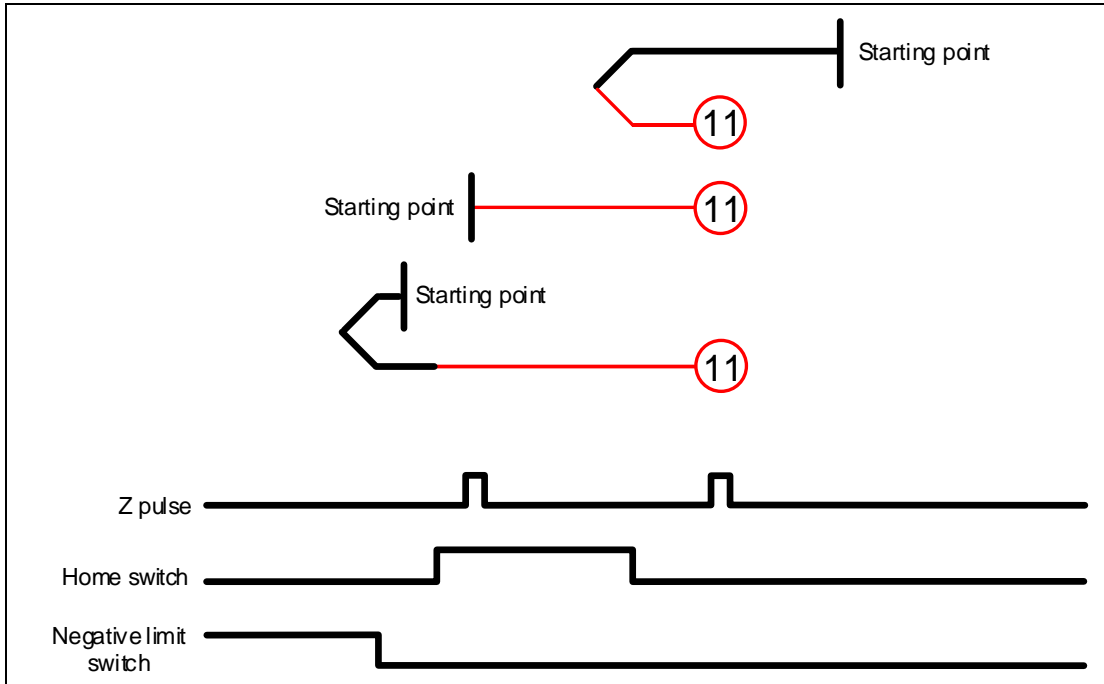

Method 12: homing on the negative limit switch, home switch, and Z pulse

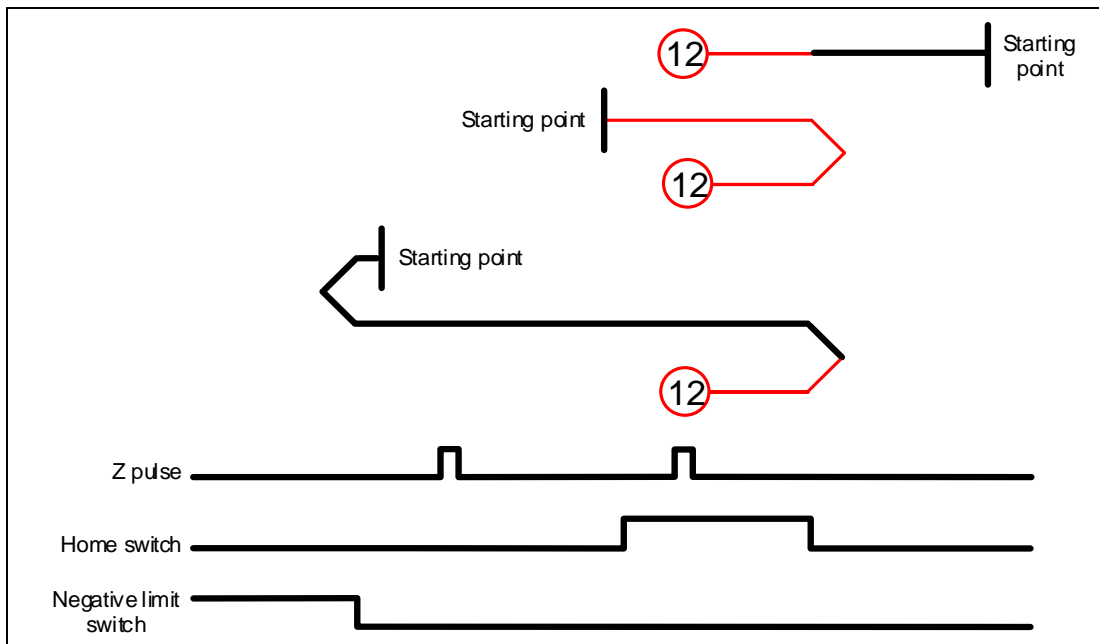

Method 13: homing on the negative limit switch, home switch, and Z pulse

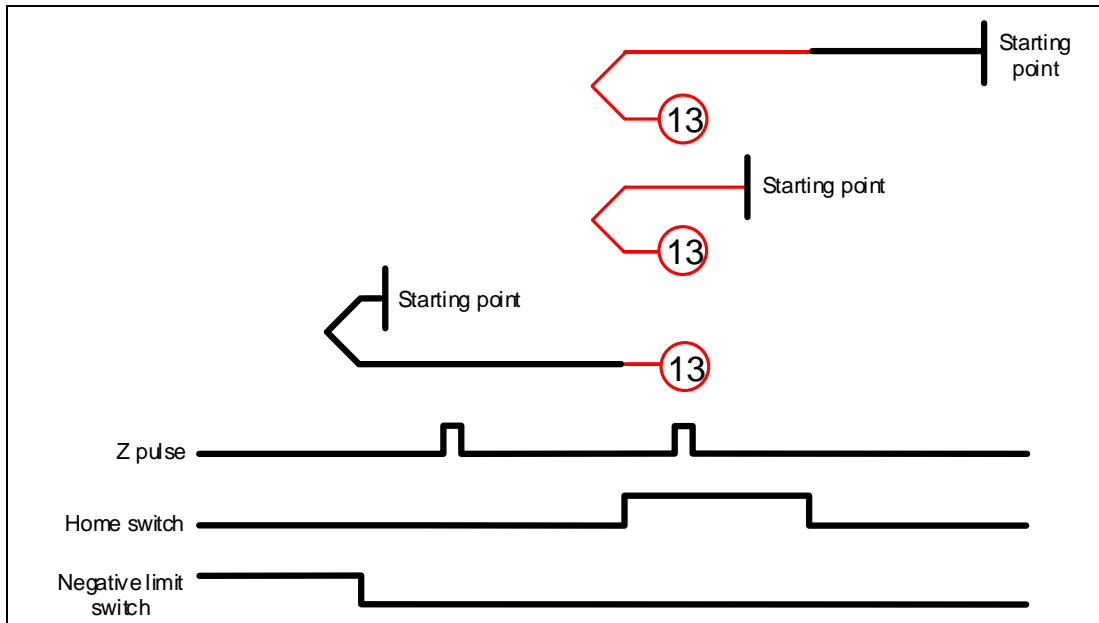

Method 14: homing on the negative limit switch, home switch, and Z pulse

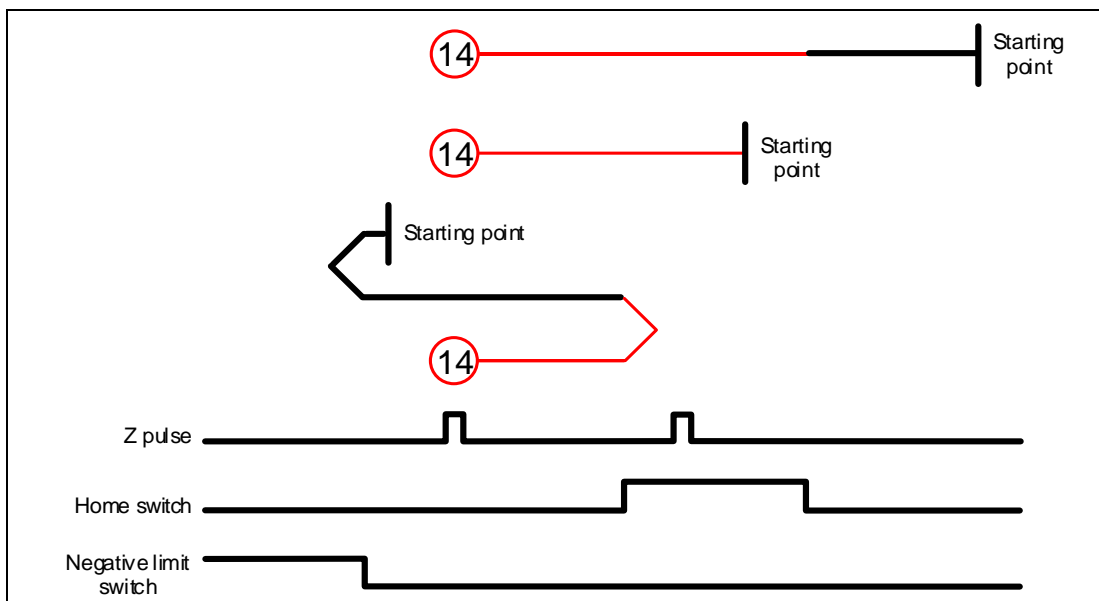

Methods 15 and 16: reserved

Method 17: homing on the negative limit switch

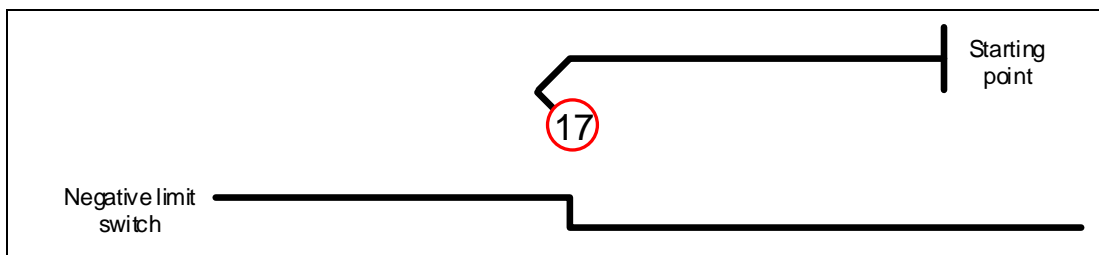

12

Method 18: homing on the positive limit switch

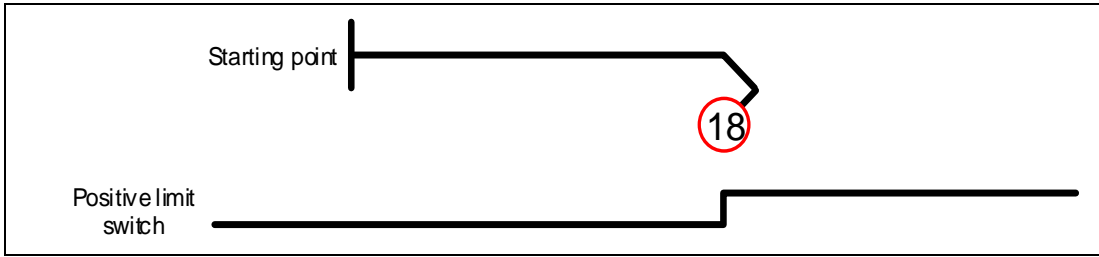

Methods 19 and 20: homing on the home switch

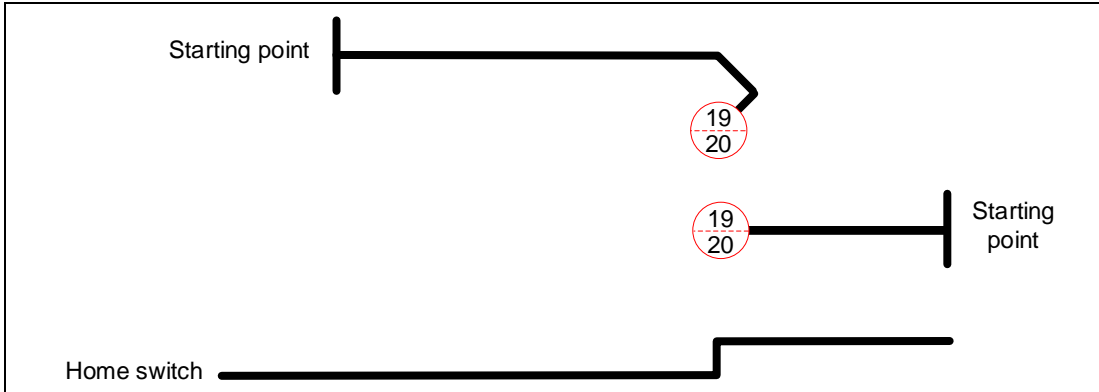

Methods 21 and 22: homing on the home switch

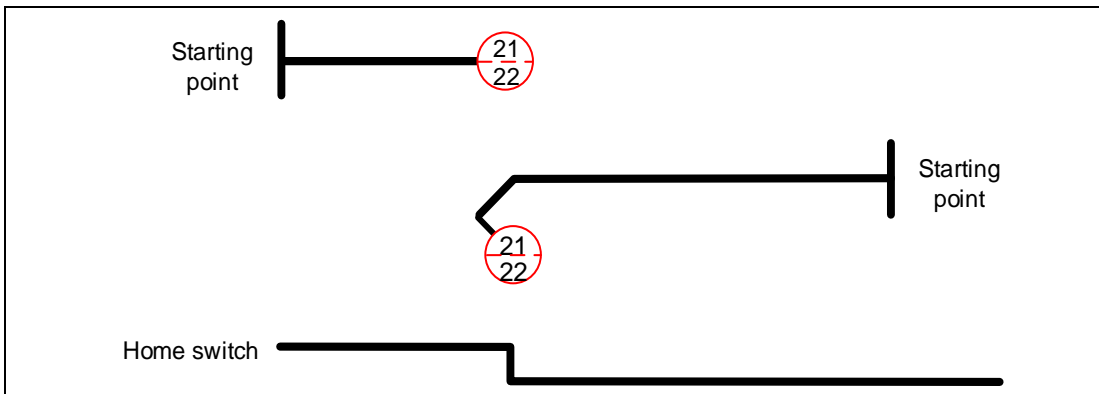

Methods 23 and 24: homing on the positive limit switch and home switch

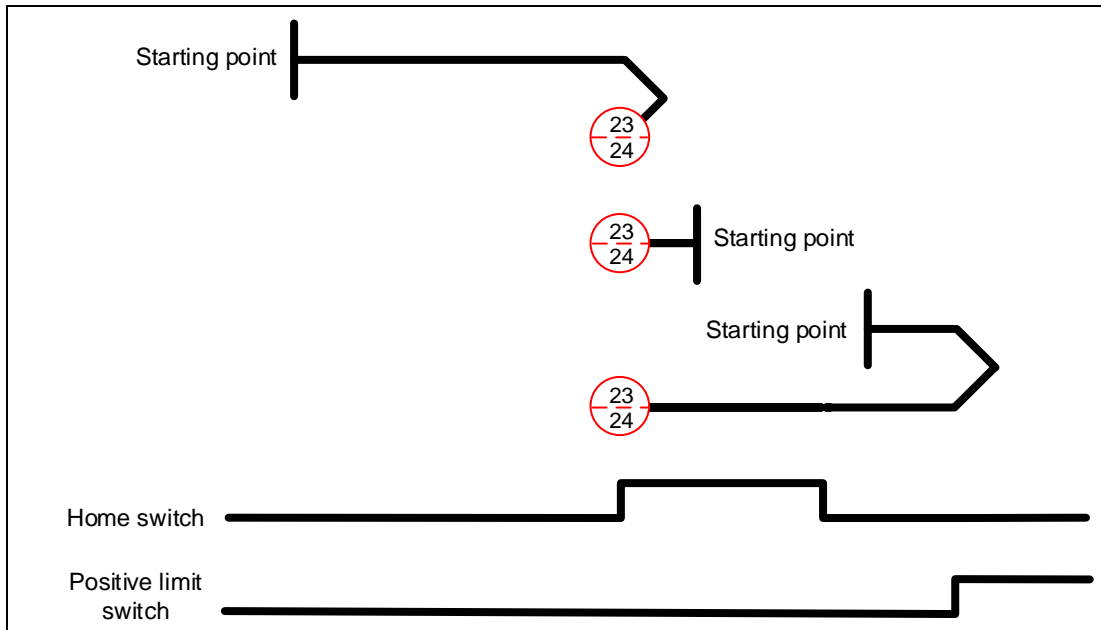

Methods 25 and 26: homing on the positive limit switch and home switch

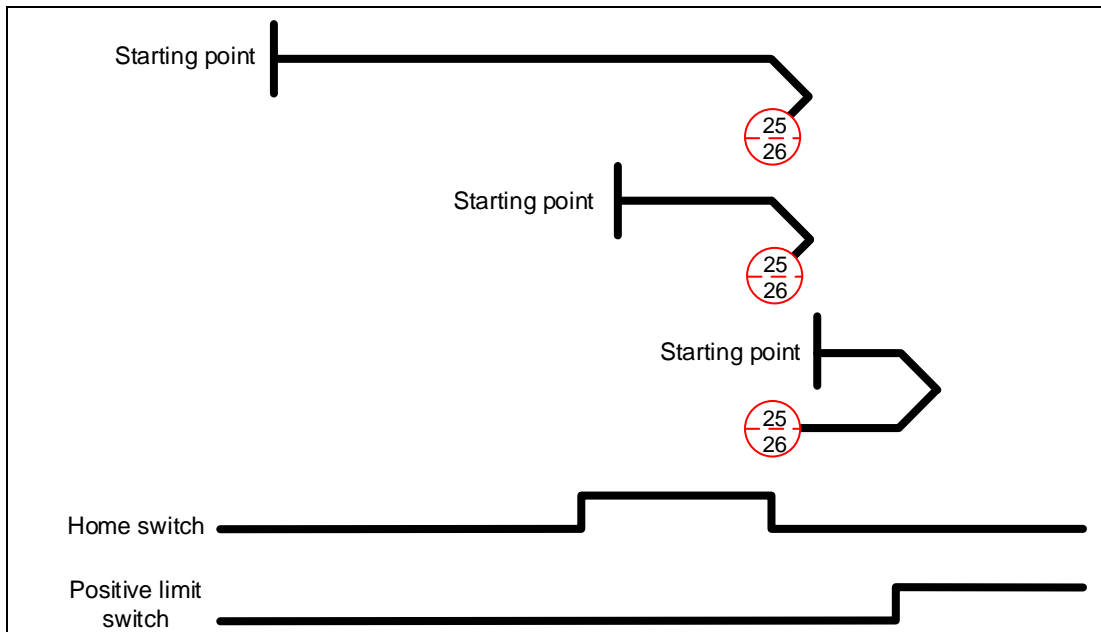

# 12

Methods 27 and 28: homing on the negative limit switch and home switch

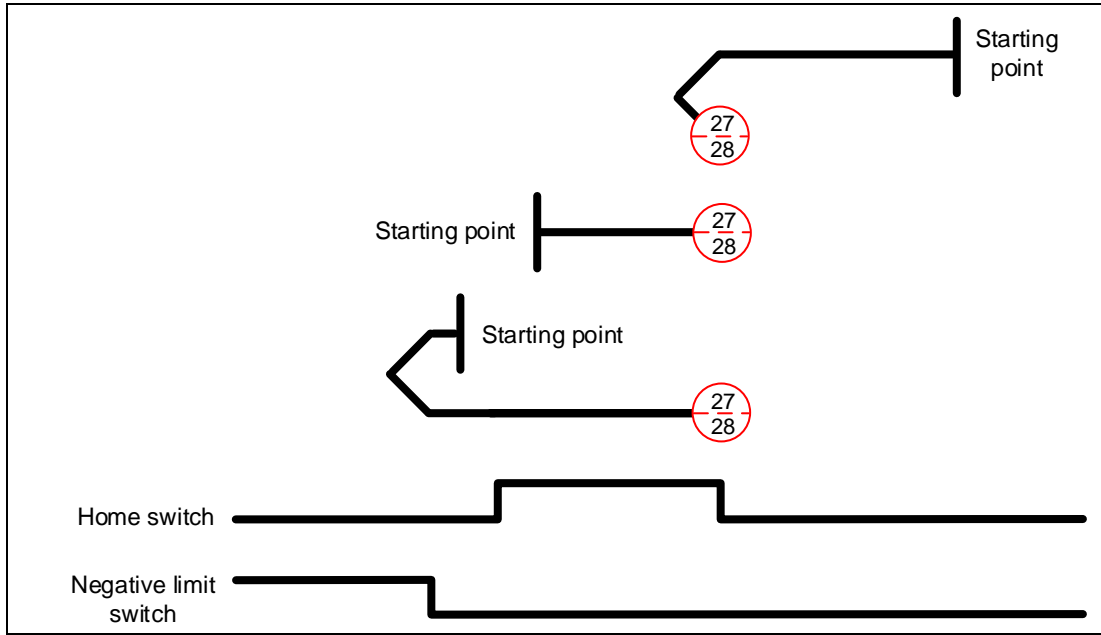

Methods 29 and 30: homing on the negative limit switch and home switch

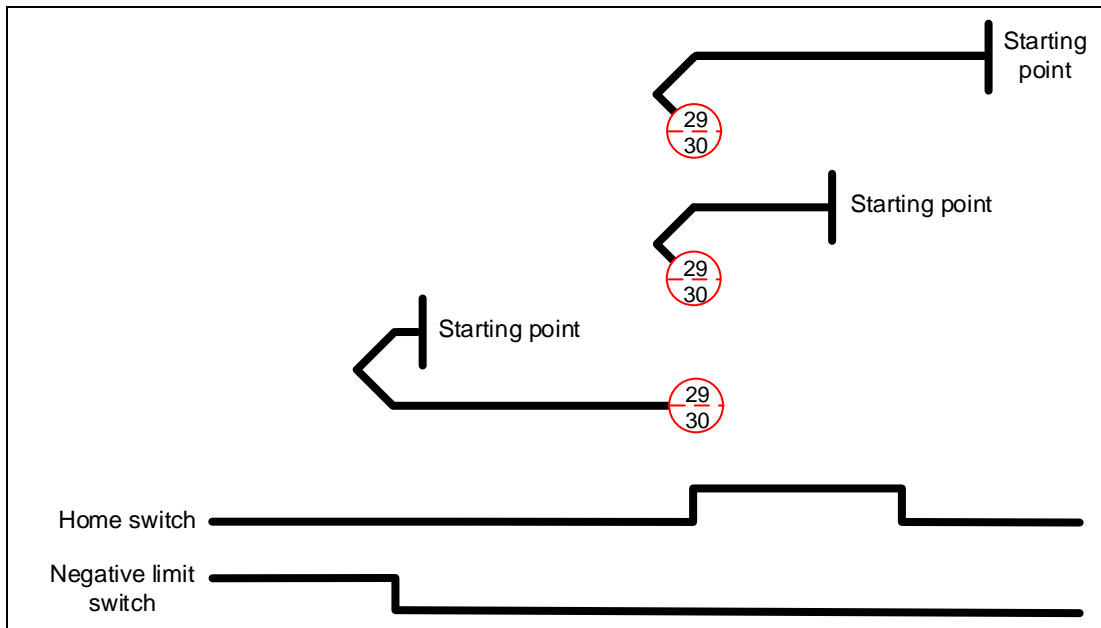

Methods 31 and 32: reserved

Methods 33 and 34: homing on the Z pulse

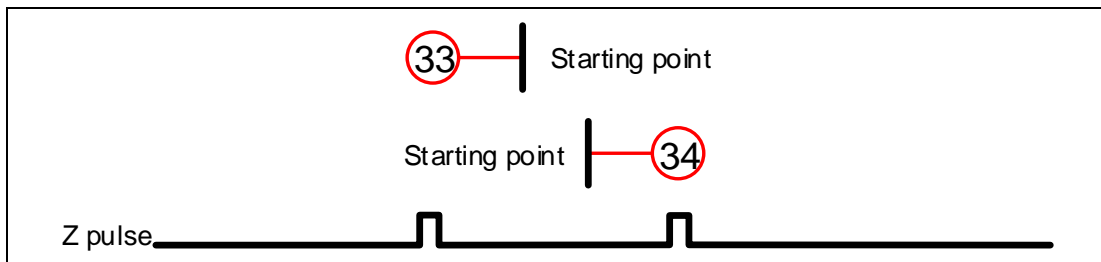

Method 35: defines the current feedback position as the origin

Methods 36 and 37:

When OD 6098h is set to -1 or -2: homing on the hard stop and Z pulse

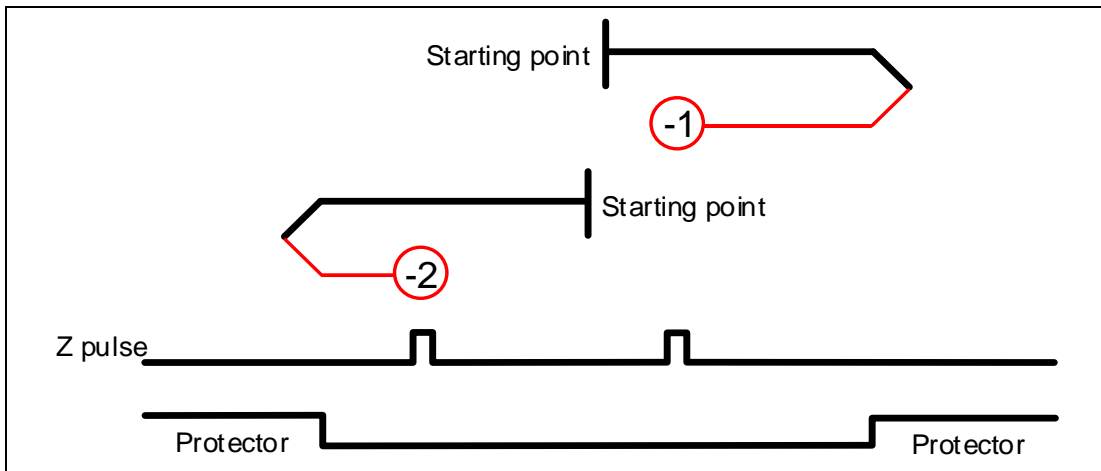

12

Methods 38 and 39:

When OD 6098h is set to -3 or -4: homing on the hard stop

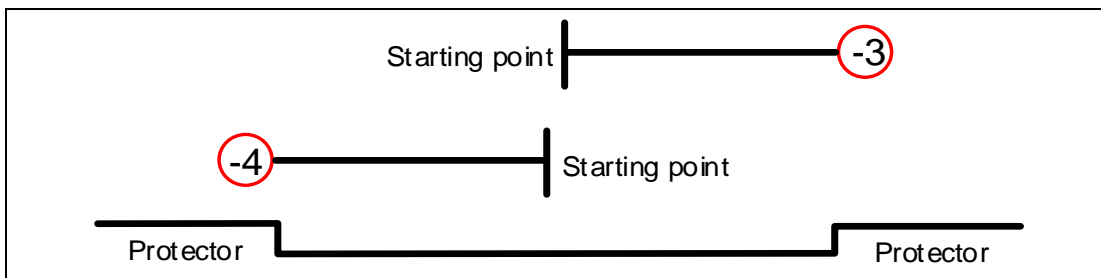

## 12

## Object 6099h: Homing speeds

Index	6099h
Name	Homing speeds
Object code	ARRAY
Data type	UNSIGNED32
Access	RW
PDO mapping	Yes

Sub-index	0
Description	Number of sub-index
Data type	UNSIGNED8
Access	RO
PDO mapping	Yes
Setting range	2
Default	2

Sub-index	1
Description	Speed during search for switch
Data type	UNSIGNED32
Access	RW
PDO mapping	Yes
Setting range	1 - 20000
Default	100
Unit	0.1 rpm (rotary motor) 1 $\mu$ m/s (linear motor)

Sub-index	2
Description	Speed during search for zero
Data type	UNSIGNED32
Access	RW
PDO mapping	Yes
Setting range	1 - 5000
Default	20
Unit	0.1 rpm (rotary motor) 1 $\mu$ m/s (linear motor)

## Object 609Ah: Homing acceleration

Index	609Ah
Name	Homing acceleration
Object code	VAR
Data type	UNSIGNED32
Access	RW
PDO mapping	Yes
Setting range	UNSIGNED32
Default	100
Unit	ms

## Object function:

The time slope set by this object is the time required for the motor to accelerate from 0 rpm to 3,000 rpm and decelerate from 3,000 rpm to 0 rpm. This object only works in Homing mode.

## Object 60C0h: Interpolation sub mode select

Index	60C0h
Name	Interpolation sub mode select
Object code	VAR
Data type	INTEGER16
Access	RW
PDO mapping	Yes
Setting range	INTEGER16
Default	0

## Object function:

No need to set this object.



## 12

## Object 60C1h: Interpolation data record

Index	60C1h
Name	Interpolation data record
Object code	ARRAY
Data type	INTEGER32
Access	RW
PDO mapping	Yes

Sub-index	0
Description	Number of sub-index
Data type	UNSIGNED8
Access	RO
PDO mapping	No
Setting range	2
Default	2

Sub-index	1
Description	Command position Pos_Cmd
Data type	INTEGER32
Access	RW
PDO mapping	Yes
Setting range	INTEGER32
Default	0
Unit	PUU

## Object function:

This object only works in Interpolated Position mode. For more details, refer to Section 12.3.2.

## Object 60C2h: Interpolation time period

Index	60C2h
Name	Interpolation time period
Object code	RECORD
Data type	UNSIGNED8
Access	RW
PDO mapping	Yes

Sub-index	0
Description	Number of sub-index
Data type	UNSIGNED8
Access	RO
PDO mapping	No
Setting range	2
Default	2

Sub-index	1
Description	Interpolation time units
Data type	UNSIGNED8
Access	RW
PDO mapping	Yes
Setting range	UNSIGNED8
Default	1

Sub-index	2
Description	Interpolation time index
Data type	INTEGER8
Access	RW
PDO mapping	Yes
Setting range	-128 to +63
Default	-3

## Object function:

This object only works in Interpolated Position mode. The interpolation time period is calculated by OD 60C2h sub1 and OD 60C2h sub2. The calculation is as follows:

$$\text{Interpolation time period} = 60C2h \text{ sub1} \times 10^{60C2h \text{ sub2}}$$

## Example:

If you want to set the interpolation time period to 2 ms, set OD 60C2h sub1 to 2 and OD 60C2h sub2 to -3.

$$\text{Interpolation time period} = 2 \times 10^{-3} = 0.002 \text{ s} = 2 \text{ ms}$$

## 12

## Object 60C5h: Max acceleration

Index	60C5h
Name	Max acceleration
Object code	VAR
Data type	UNSIGNED32
Access	RW
PDO mapping	Yes
Setting range	1 - 65500
Default	1
Unit	ms

## Object function:

The time slope set by this object is the time required for the motor to accelerate from 0 rpm to 3,000 rpm.

## Object 60C6h: Max deceleration

Index	60C6h
Name	Max deceleration
Object code	VAR
Data type	UNSIGNED32
Access	RW
PDO mapping	Yes
Setting range	1 - 65500
Default	1
Unit	ms

## Object function:

The time slope set by this object is the time required for the motor to decelerate from 3,000 rpm to 0 rpm.

Object 60F4h: Following error actual value

Index	60F4h
Name	Following error actual value
Object code	VAR
Data type	INTEGER32
Access	RO
PDO mapping	Yes
Setting range	INTEGER32
Default	0
Unit	PUU

Object function:

The following error actual value is the difference between the position demand value (OD 6062h) and position actual value (OD 6064h). For more details, refer to the architecture diagrams in Section 12.3.

Object 60FCh: Position demand value

Index	60FCh
Name	Position demand value
Object code	VAR
Data type	INTEGER32
Access	RO
PDO mapping	Yes
Setting range	INTEGER32
Default	0
Unit	pulse

Object function:

This command is generated after being processed by the servo drive filter. For more details, refer to the architecture diagrams in Section 12.3.

## 12

## Object 60FDh: Digital inputs

Index	60FDh
Name	Digital inputs
Object code	VAR
Data type	UNSIGNED32
Access	RO
PDO mapping	Yes
Setting range	UNSIGNED32
Default	0
Unit	-

## Object function:

Bit	15	14	13	12	11	10	9	8	7	6	5	4	3	2	1	0
-----	----	----	----	----	----	----	---	---	---	---	---	---	---	---	---	---

Bit	Function
Bit 0	Negative limit signal
Bit 1	Positive limit signal
Bit 2	Homing signal
Bit 3 - Bit 15	Reserved

## Object 60FEh: Digital outputs

Index	60FEh
Name	Digital outputs
Object code	ARRAY
Data type	UNSIGNED32
Access	RW

Sub-Index	0
Description	Number of sub-index
Data type	UNSIGNED8
Access	RO
PDO mapping	Yes
Setting range	2
Default	2

Sub-Index	1
Description	Physical outputs
Data type	UNSIGNED32
Access	RW
PDO mapping	Yes
Setting range	0x00000000 to 0xFFFFFFFF
Default	0

Sub-Index	2
Description	Bit mask
Data type	UNSIGNED32
Access	RW
PDO mapping	Yes
Setting range	0x00000000 to 0xFFFFFFFF
Default	0

Object function:

#### OD 60FEh sub1 Physical outputs

Bit	DO	Description
0 - 15	-	Reserved
16	DO1	0: off; 1: on
17	DO2	0: off; 1: on
18	DO3	0: off; 1: on
19	DO4	0: off; 1: on
20 - 31	-	Reserved

#### OD 60FEh sub2 Bit mask

Bit	DO	Description
0 - 15	-	Reserved
16	DO1	0: disable physical outputs; 1: enable
17	DO2	0: disable physical outputs; 1: enable
18	DO3	0: disable physical outputs; 1: enable
19	DO4	0: disable physical outputs; 1: enable
20 - 31	-	Reserved

## 12

- To use the software to control the DO output, you must first set the corresponding DO function code.  
When P2.018 = 0x0130, the output of DO1 is controlled by the software.  
When P2.019 = 0x0131, the output of DO2 is controlled by the software.  
When P2.020 = 0x0132, the output of DO3 is controlled by the software.  
When P2.021 = 0x0133, the output of DO4 is controlled by the software.
- DO output settings  
When the corresponding OD 60FEh sub2 bit of the DO is set to 1, the output status of this DO is determined by the corresponding bit of OD 60FEh sub1.  
When the corresponding OD 60FEh sub2 bit of the DO is set to 0, the output status of this DO is determined by P4.006.
- Example:
  1. Set P2.018 to 0x0130, which means the output of DO1 is controlled by the software.
  2. When OD 60FEh sub2 [Bit 16] is 1, the output status of DO1 is determined by OD 60FEh sub1 [Bit 16]. When OD 60FEh sub2 [Bit 16] is 0, the output status of DO1 is determined by P4.006 [Bit 0].

Object 60FFh: Target velocity

Index	60FFh
Name	Target velocity
Object code	VAR
Data type	INTEGER32
Access	RW
PDO mapping	Yes
Setting range	INTEGER32
Default	0
Unit	0.1 rpm

Object function:

This object sets the target velocity. This object only works in Profile Velocity mode.

## Object 6502h: Supported drive modes

Index	6502h
Name	Supported drive modes
Object code	VAR
Data type	UNSIGNED32
Access	RO
PDO mapping	Yes
Setting range	UNSIGNED32
Default	6Dh

## Object function:

This object is read-only and provides the operation modes supported by Delta servo drives in CANopen mode.

Bit	31	30	29	28	27	26	25	24	23	22	21	20	19	18	17	16
Bit	15	14	13	12	11	10	9	8	7	6	5	4	3	2	1	0

Bit	Function
Bit 0	Profile Position mode
Bit 1	Reserved
Bit 2	Profile Velocity mode
Bit 3	Profile Torque mode
Bit 4	Reserved
Bit 5	Homing mode
Bit 6	Interpolated Position mode
Bit 7 - Bit 31	Reserved



## 12

## 12.5 Diagnostics and troubleshooting

This section provides diagnostics and troubleshooting information related to communication or interference with the controller. For information about the servo drive alarms, refer to Chapter 14 Troubleshooting.

1. The SYNC communication cycle of the controller and servo drive is different

Since the jitter of each controller is different, the time the servo drive receives the SYNC differs from the SYNC communication cycle time. When this happens, adjust the value of P3.009.U to increase the error range and let the servo drive automatically correct the internal timer so it is consistent with the communication cycle of the controller.

2. Eliminate interference

Packets are particularly sensitive to interference in high-speed network communication applications. To achieve fast and high-precision control, the selection of the wire is extremely important. Use shielded cables for the communication wiring, and make sure that the cable shield is firmly connected to the servo drive communication port. Also, ensure the ground wire is properly connected and grounded.

# EtherCAT Mode

# 13

This chapter provides details for the required parameter settings when the servo communicates with the controller through the EtherCAT communication function.

13.1	Basic configuration	13-3
13.1.1	Hardware configuration	13-3
13.1.2	ESI file import	13-7
13.1.3	Parameter settings of EtherCAT mode	13-8
13.2	Communication function	13-12
13.2.1	Specifications	13-12
13.2.2	Synchronization mode	13-14
13.2.2.1	Synchronization modes of the servo drive	13-14
13.2.2.2	Select Synchronization mode	13-15
13.2.2.3	Distributed clocks setting	13-15
13.2.3	EtherCAT state machine	13-16
13.2.4	PDO mapping configuration	13-18
13.2.4.1	Default PDO mapping configuration	13-18
13.2.4.2	Set PDO mapping	13-20
13.2.4.3	PDO mapping object	13-21
13.2.4.4	SDO abort codes	13-22
13.3	EtherCAT operation modes	13-23
13.3.1	Profile Position mode	13-23
13.3.2	Profile Velocity mode	13-28
13.3.3	Profile Torque mode	13-30
13.3.4	Homing mode	13-32
13.3.5	Cyclic Synchronous Position mode	13-34
13.3.6	Cyclic Synchronous Velocity mode	13-36
13.3.7	Cyclic Synchronous Torque mode	13-38
13.3.8	Touch Probe function and Touch Probe status	13-40
13.4	Object dictionary	13-45
13.4.1	Specifications for objects	13-45
13.4.2	List of objects	13-46
13.4.3	Details of objects	13-48
13.4.3.1	OD 1XXXh communication object group	13-48
13.4.3.2	OD 2XXXh servo parameter group	13-54

# 13

- 13.4.3.3 OD 6XXXh communication object group ..... 13-55
- 13.5 Diagnostics and troubleshooting..... 13-96
  - 13.5.1 EtherCAT Diagnosis ..... 13-96
  - 13.5.2 Alarm list..... 13-97

## 13.1 Basic configuration

### 13.1.1 Hardware configuration

The pin assignments of the two EtherCAT connectors (CN6) are the same. Note that the IN connector can connect to the controller (master) or the previous servo drive for receiving signals, and the OUT connector can only connect to the next servo drive for outputting signals. Incorrect connection will cause communication failure.

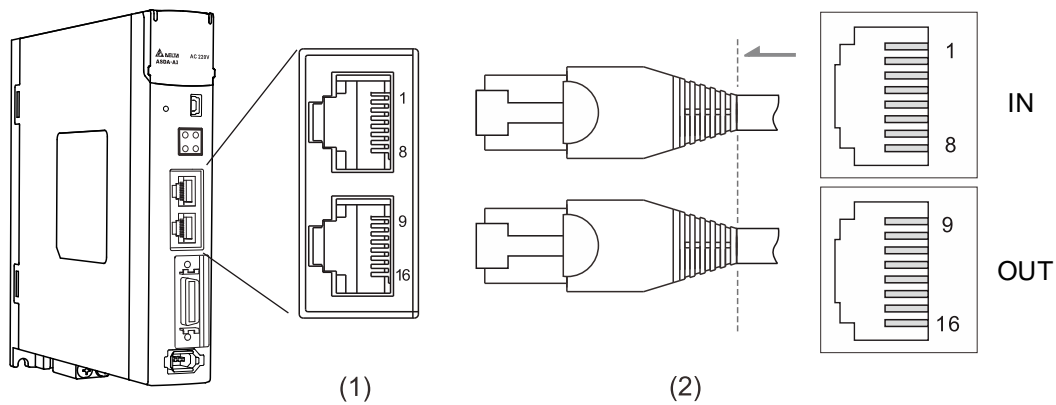

(1) CN6 connector (female); (2) CN6 connector (male)

Pin assignment:



Pin No.	Terminal	Signal	Description
1, 9	TX+	TX+	Transmit+
2, 10	TX-	TX-	Transmit -
3, 11	RX+	RX+	Receive+
4, 12	-	-	Reserved
5, 13	-	-	Reserved
6, 14	RX-	RX-	Receive-
7, 15	-	-	Reserved
8, 16	-	-	Reserved

# 13

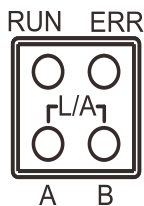
Description of each indicator for the CN6 connector:

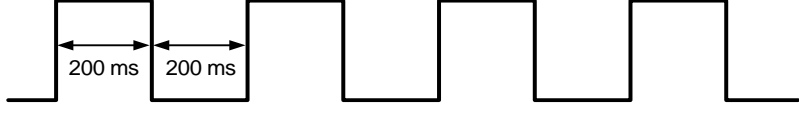
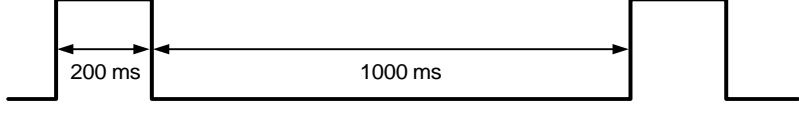

■ LED indicator status description

Indicator	Description
Steady on	ON  OFF
Continuous flashing	ON  OFF
Single flashing	ON  OFF
Steady off	ON OFF 

■ Network status indicator (L/A)

Indicator	Status	Description
Steady on	Connection is established.	Connection is established but no data transmission.
Continuous flashing	Connection is established and data is in transmission.	Data is in transmission.
Steady off	No connection.	Connection is not established.

■ EtherCAT connection status indicator (RUN)

Indicator	Status	Description
Steady off	Init	After power cycling and the initialization of the servo drive is complete, the communication has not yet started, but the controller can access the servo drive's register.
Steady on	Operational	SDO, TxPDO, and RxPDO data packets can be transmitted.
Continuous flashing	Pre-Operational	The controller can exchange data through the mailbox.
Single flashing	Safe-Operational	The servo drive can use the SDO and TxPDO data packets to exchange data with the controller.

■ EtherCAT error indicator (ERR)

Indicator	Status	Description
Steady off	No error	No error has occurred.
Steady on	PDI Watchdog timeout	Servo drive malfunction. Contact Delta's distributor for assistance.
Continuous flashing	State change error	Parameter setting error causes the system unable to switch states. Refer to Figure 13.1.1.1.
Single flashing	Synchronization error / SyncManager error	The synchronization between the controller and the servo drive failed or the data was lost during data reception.

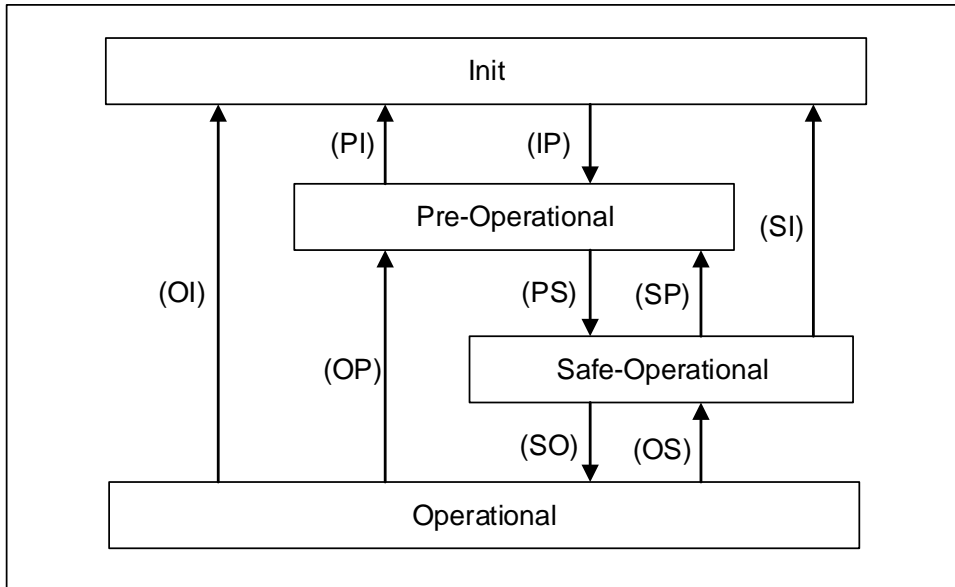
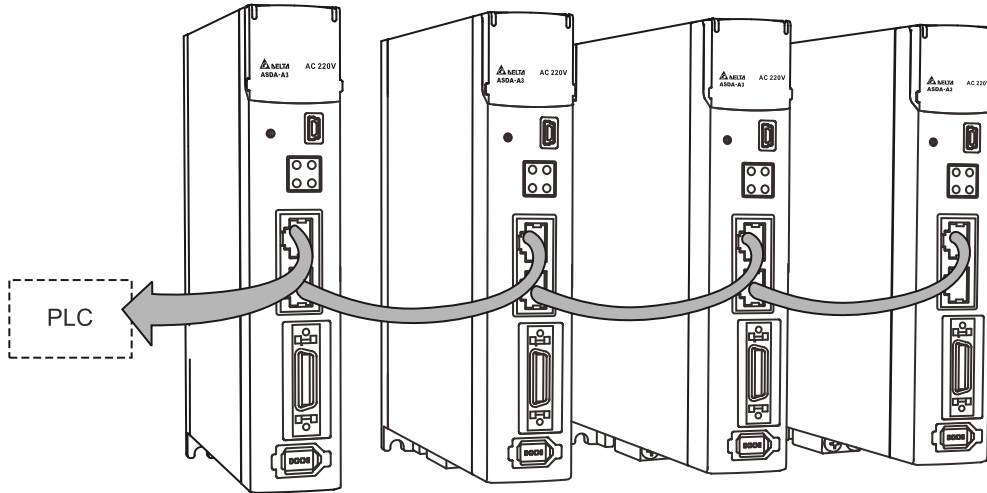

Figure 13.1.1.1 State transition diagram

# 13

Connecting multiple servo drives:



Note:

1. When multiple servo drives are connected, the maximum distance between each drive is 50 m (164.04 inches).
2. Use CAT5e shielded twisted-pair (STP) cables with metal connectors.
3. It is suggested that you use a Beckhoff cable (model number: ZB9020).
4. Check if the wiring is correct. Note that the IN connector can connect to the controller (master) or the previous servo drive for receiving signals, and the OUT connector can only connect to the next servo drive for outputting signals.

### 13.1.2 ESI file import

EtherCAT is an open motion control bus that requires using the ESI (EtherCAT Slave Information) file to configure the functions and related object properties for each slave device. Generally, the ESI file is an XML file.

#### Delta controller

No need to import ESI files.

#### Non-Delta controller

Import the ESI file of the slave device to the controller software, so the controller can recognize and control each slave device according to the configuration in the ESI file. An ESI file may contain data of multiple devices. Delta's A3-E and B3-E servo drives share the same ESI file. To import ESI files to non-Delta controllers, refer to the manufacturer's instruction manual.

Download the dedicated ESI file for the A3-E and B3-E servo drives from the [Download Center](#) of Delta's website.

The storage paths of ESI files for the non-Delta controllers are as follows:

#### Beckhoff TwinCAT

TwinCAT 2: C:\TwinCAT\IO\EtherCAT

TwinCAT 3: C:\TwinCAT\3.1\Config\Io\EtherCAT

#### Omron Sysmac Studio

C:\Program Files (x86)\OMRON\Sysmac Studio\IODeviceProfiles\EsiFiles\UserEsiFiles

Note: refer to the manufacturer's instruction manual of each controller for the actual storage path.



### 13.1.3 Parameter settings of EtherCAT mode

Follow these instructions to connect the EtherCAT controller and the ASDA-A3 servo drive:

# 13

1. Set to EtherCAT mode: set P1.001.YX to 0C.
2. Set the slave station number: set P3.000 to 0x0001 - 0x007F.
3. It is suggested that you change the setting value of P3.012.Z from 0 (default) to 1 to enable the non-volatile setting for the parameter. Note that the default E-Gear ratio varies with the set value of P3.012.Z.

Settings	P3.012 = 0x0100 (Z = 1)		P3.012 = 0x0000 (Z = 0)	
	Servo parameter	Default	OD address	Default
Motor stop mode	P1.032	0x0000	605Bh	0
S-curve acceleration constant	P1.034	200	6087h	200
Zero speed range	P1.038	100 (rotary*: 0.1 rpm; linear*: 0.1 mm/s)	606Fh	100 (0.1 rpm)
E-Gear ratio - numerator N1	P1.044	16777216	6093h sub1	1
E-Gear ratio - denominator M	P1.045	100000	6093h sub2	1
Speed reached (DO.SP_OK) range	P1.047	10 (rotary*: rpm; linear*: mm/s)	606Dh	100 (0.1 rpm)
Accumulated time to reach desired speed	P1.049	0	606Eh	0
Maximum speed limit	P1.055	Depending on the motor (rotary*: 1 rpm; linear*: 1 mm/s)	607Fh	Depending on the motor (0.1 rpm)
			6080h	Depending on the motor (rpm)
Excessive deviation warning condition of Position command	P2.035	50331648	6065h	50331648
Positive software limit (PP / CSP / CSV / CST mode)	P5.008	2147483647	607Dh sub2	2147483647
Negative software limit (PP / CSP / CSV / CST mode)	P5.009	-2147483648	607Dh sub1	-2147483648
Origin definition (HM mode)	P6.001	0	607Ch	0

Note: rotary means a permanent-magnet synchronous rotary motor;  
linear means a permanent-magnet synchronous linear motor.

<b>P3.009</b>	<b>Communication synchronization</b>		<b>Address: 0312H 0313H</b>
Default:	0x5055	Control mode:	CANopen / EtherCAT
Unit:	-	Setting range:	Shown as follows
Format:	HEX	Data size:	16-bit

Settings:



U Z Y X

Digit	Z
Function	Target value (EtherCAT)
Range	M, F, L: 0 to F E: 0 to A

Z: when the servo is operating in the DC-Synchronous mode, you can adjust the timing of the servo accessing EtherCAT packets to ensure that this timing is not conflict with the timing of the controller sending the packets. The delay time in the following figure is  $(T/10) \times Z$  ( $\mu$ s).

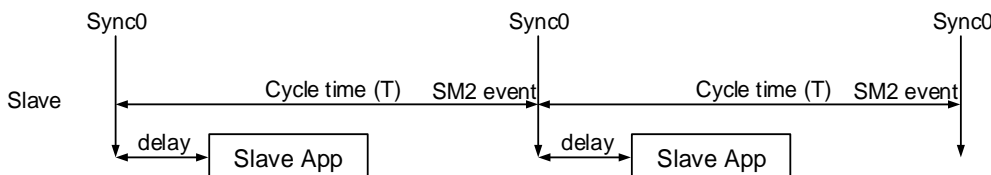

<b>P3.018</b>	<b>EtherCAT special function switch</b>		<b>Address: 0324H 0325H</b>
Default:	0x00002000	Control mode:	EtherCAT
Unit:	-	Setting range:	0x00000000 - 0x00112211
Format:	HEX	Data size:	32-bit

Settings:



A	Source setting for the content loaded to the EtherCAT Station Alias Register 0x0012 after the servo drive is powered on	X	Unit selection for Target velocity (OD 60FFh) and Velocity actual value (OD 606Ch) when in the PV (Profile Velocity) mode or CSV (Cyclic Synchronous Velocity) mode
B	Reserved	Y	Reserved
C	Unit selection for the maximum speed of OD 607Fh and OD 6080h	Z	AL185 communication disconnection detection setting
D	Reserved	U	Reserved

- A: source setting for the content loaded to the EtherCAT Station Alias Register 0x0012 after the servo drive is powered on.

0: determined by the EtherCAT EEPROM station number field (ADR 0x0004) setting, which needs to be set via the controller interface.

1: determined by the station number set with servo parameter P3.000.

# 13

- X: unit selection for Target velocity (OD 60FFh) and Velocity actual value (OD 606Ch) when in the PV (Profile Velocity) mode or CSV (Cyclic Synchronous Velocity) mode

0: 0.1 rpm

1: pulse/sec
- Z: AL185 communication disconnection detection setting

0: disconnection detection starts after EtherCAT communication enters OP state.

1: disconnection detection starts after EtherCAT communication enters Init state.

2: disable disconnection detection.

Note: when using the ring topology connection, set P3.018.Z to 2 to disable the disconnection detection.
- C: unit selection for the maximum speed of OD 607Fh and OD 6080h

0: 0.1 rpm for OD 607Fh and rpm for OD 6080h.

1: pulse/sec for OD 607Fh and OD 6080h.

P3.022	EtherCAT PDO timeout setting		Address: 032CH 032DH
Default:	0xFF04	Control mode:	EtherCAT
Unit:	-	Setting range:	0x0002 - 0xFF14
Format:	HEX	Data size:	16-bit

Settings:

When using the PDO to transmit data periodically, use this parameter to set the timeout setting.

The following two sets of digits specify the trigger conditions for AL180 and AL3E3 respectively to ensure that the servo drive receives the PDO. When one of the alarm occurs, it means the allowable duration for packet loss exceeds the set range.



U Z Y X

Digit	UZ	YX
Function	AL180 trigger condition	AL3E3 trigger condition
Range	0x00 (disabled) - 0xFF (default)	0x02 - 0x14

- YX: AL3E3 trigger condition (allowable cycle for elapsed time); applicable to CSP / CSV / CST mode.

AL3E3 occurs when the servo drive does not receive the PDO within the set cycle.

When the communication cycle is 4 ms and you set this parameter to 0x02 (allow two cycles), it means if the servo drive does not receive any PDO within 8 ms, AL3E3 occurs.
- UZ: AL180 trigger condition (allowable duration for elapsed time); applicable to all operation modes.

AL180 occurs when the servo drive does not receive the PDO within the set duration (unit: ms). For example, when you set P3.022.UZ to 0x01, the duration is 1 ms; when you set P3.022.UZ to 0x02, the duration is 2 ms; and when you set P3.022.UZ to 0xFF, the duration is 255 ms.

P0.002	Drive status		Address: 0004H 0005H
Default:	1	Control mode:	All
Unit:	-	Setting range:	-300 to +127
Format:	DEC	Data size:	16-bit

13

## Settings:

Input the monitoring code to P0.002 to view changes to the variable on the panel. For the list of monitoring variables, refer to Table 8.3 Monitoring variables descriptions.

Monitoring variables related to EtherCAT communication are as follows.

Code	Variable name	Description
119 (77h)	EtherCAT state machine	1: Init 2: Pre-Operational (Pre-OP) 4: Safe-Operational (Safe-OP) 8: Operational (OP)
120 (78h)	Communication error rate	When this value continues to increase, it indicates that there is communication interference. In an interference-free environment, this value should not increase. (Available on all models except A3-L.)

## 13.2 Communication function

### 13.2.1 Specifications

13

EtherCAT communication functions	Physical layer	100BASE-TX
	Communication connector	RJ45 × 2
	Network topology	Line connection
	Baud rate	2 x 100 Mbps (full duplex)
	Data frame length	Maximum 1,484 bytes
	SyncManager	SM0: mailbox output SM1: mailbox input SM2: process data output SM3: process data input
	Fieldbus Memory Management Units (FMMU)	FMMU0: process data output area FMMU1: process data input area FMMU2: mailbox status area
	Application layer protocol	CoE: CANopen over EtherCAT
	Synchronization mode	DC-Synchronous mode (SYNC0) Asynchronous mode (Free Run)
	Communication object	SDO: Service data object PDO: Process data object EMCY: Emergency object
	LED indicator (On RJ45 connector)	EtherCAT ERR × 1 EtherCAT Link / Activity (L/A) × 2 EtherCAT RUN × 1
	Application layer specifications	IEC61800-7 CiA DS402 Drive Profile
Supported CiA DS402 operation modes	<ul style="list-style-type: none"> <li>■ Profile Position (PP) mode</li> <li>■ Profile Velocity (PV) mode</li> <li>■ Profile Torque (PT) mode</li> <li>■ Homing (HM) mode</li> <li>■ Cyclic Synchronous Position (CSP) mode</li> <li>■ Cyclic Synchronous Velocity (CSV) mode</li> <li>■ Cyclic Synchronous Torque (CST) mode</li> </ul>	

The EtherCAT architecture of the servo drive is as follows:

- Communication profile: this protocol includes the communication objects (PDO, SDO, SYNC, and Emergency object) and related communication object dictionary.
- DS402 is the device profile for drives and motion control. It defines the behavior of each operation mode and the required object parameter settings for execution.

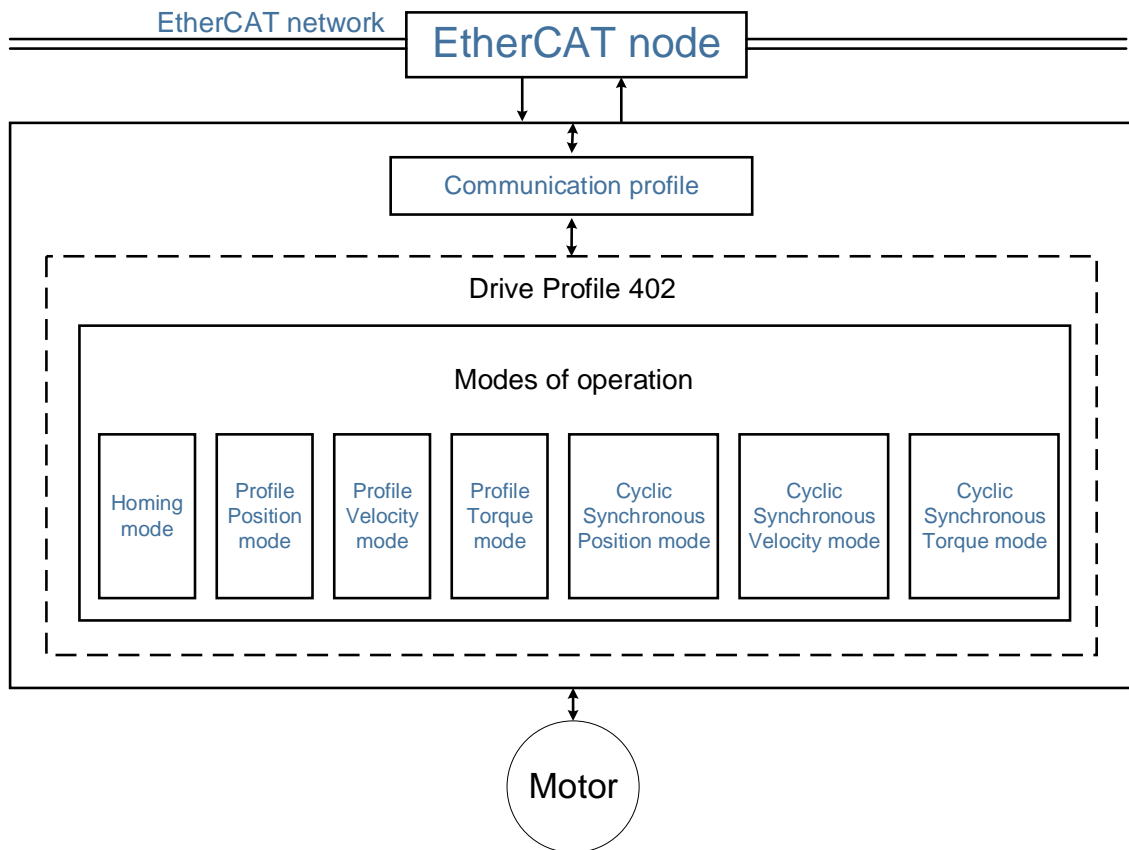

### 13.2.2 Synchronization mode

#### 13.2.2.1 Synchronization modes of the servo drive

13

The servo drive supports two synchronization modes: Free Run mode and DC-Synchronous mode. Note that the Free Run mode is defined as a synchronous mode in the EtherCAT specification established by the EtherCAT Technology Group (ETG).

##### Free Run mode (Asynchronous)

Actually, the master and slave stations run asynchronously in the Free Run mode. The clock of the slave runs independently of the clock of the master. In other words, the clocks are not synchronized. The command and feedback transmissions between the master and slave are based on a sequential order instead of a precise time synchronization. For example, the master sends a PDO at the time T1, and the slave receives the PDO at the time T2 after the SM2 event.

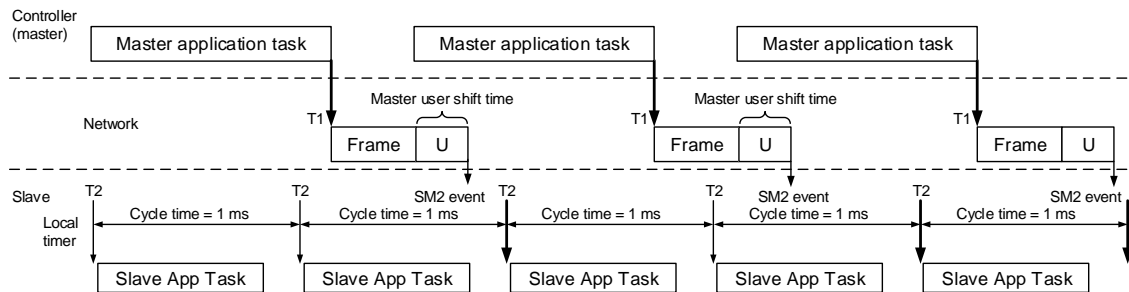

##### DC-Synchronous mode (SYNC0 synchronization)

There is precise time synchronization between the master and slave stations in the DC-Synchronous mode. The master periodically executes the control program and sends PDO packets at a fixed time according to the distributed clocks (DC), and then transmits the command to the slave and receives the feedback from the slave. The slave receives and updates the PDO data at a fixed time according to the distributed clocks.

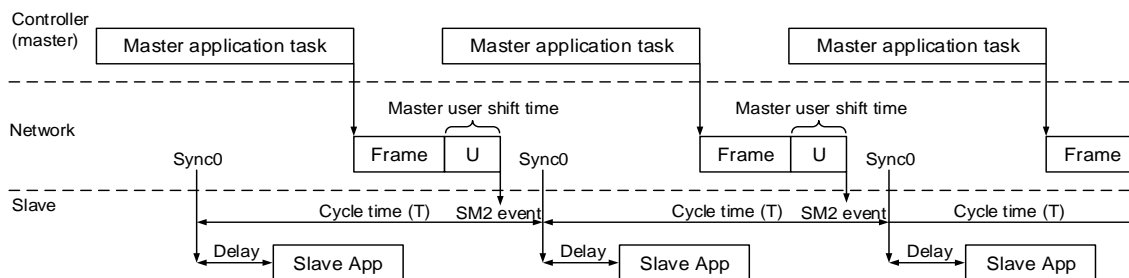

Note: Delay = P3.009.Z \* (T/10) (μs)

### 13.2.2.2 Select Synchronization mode

Follow these steps to select DC-Synchronous or Free Run mode.

1. Select **Drive 3 (ASDA-A3-E CoE Drive)** in the left column of the TwinCAT System Manager window.
2. Under the **DC** tab in the right column, select **DC-Synchronous** or **Free Run** as the Operation Mode.

### 13.2.2.3 Distributed clocks setting

Follow these steps to set the data exchange cycle.

1. Select **NC-Task 1 SAF** in the left column.
2. Set the data exchange cycle in the **Cycle ticks** field under the **Task** tab in the right column.

The SYNC0 cycle is used to define the PDO cycle time. The minimum unit of the SYNC0 cycle for A3-E and B3-E is 125  $\mu$ s. The SYNC0 cycles within 1 ms are 125  $\mu$ s, 250  $\mu$ s, and 500  $\mu$ s in sequence. The SYNC0 cycles above 1 ms are accumulated at intervals of 1 ms, such as 1 ms, 2 ms, 3 ms...10 ms. If the configuration includes an A2-E servo drive, the unit is the minimum unit of A2-E (1 ms).



### 13.2.3 EtherCAT state machine

13

In EtherCAT communication, the servo drive's state machine can be in the following states. The controller (master) controls the servo (slave) based on the actual state. The controller needs to configure the servo drive according to the designated flow in the following figure. After the controller completes the initialization of the communication, the servo (slave) is in the Operational state and waits for the user's command to perform motion control. Use the monitoring variable P0.002 = 119 to monitor the current state of the EtherCAT state machine.

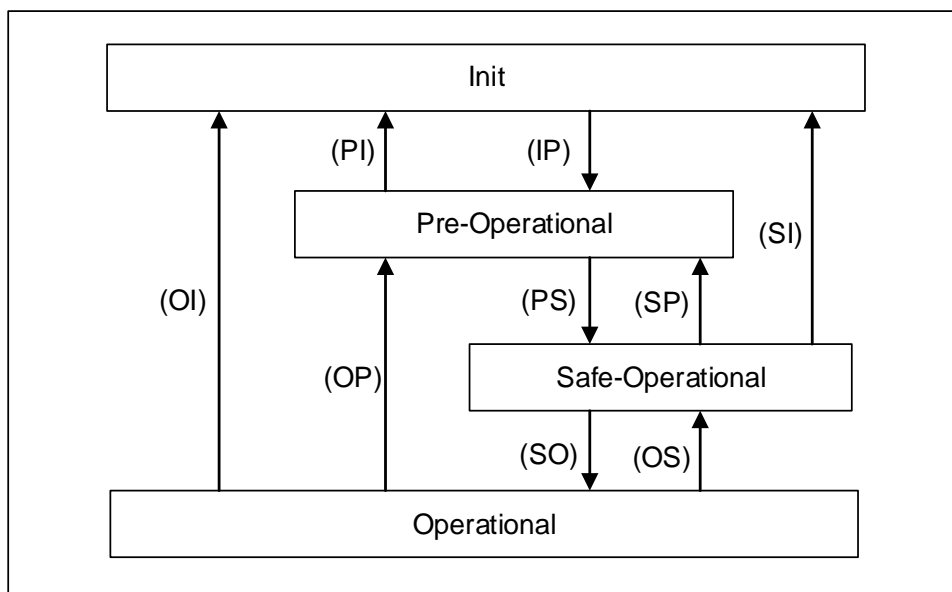

Value displayed on the panel when P0.002 = 119	State	Description
1	Init	The servo drive successfully completes initialization after being powered on without errors occurring. The packets cannot yet be transmitted in this state.
2	Pre-Operational (Pre-OP)	Data can be exchanged with SDOs. If an alarm occurs in the servo drive, an emergency message is sent to notify the controller.
4	Safe-Operational (Safe-OP)	The servo drive can use SDO and TxPDO data packets to exchange data with the controller.
8	Operational (OP)	All data exchanges including SDOs and PDOs (TxPDO and RxPDO) are allowed.

The controller (master) issues corresponding commands to the servo (slave) according to the state transition.

State transition	Description
IP	<ul style="list-style-type: none"> <li>■ The master confirms the VendorID, ProductCode and RevisionNumber of the slave.</li> <li>■ The master calibrates the distributed clocks of the slave (DC-Synchronous mode).</li> <li>■ The master defines the slave address as well as the SyncManager 0 and 1 (SM0 and SM1) register and establishes the mailbox communication.</li> <li>■ The master issues the command and confirms that the slave switches to the Pre-Operational state.</li> </ul>
PS	<ul style="list-style-type: none"> <li>■ The master uses the SDOs to set the PDO mapping and DC related parameters.</li> <li>■ The master defines the FMMU as well as the SyncManager 2 and 3 (SM2 and SM3) registers, and the slave continues to transmit PDO (TxPDO) packets to the master.</li> <li>■ The master issues the command and confirms that the slave switches to the Safe-Operational state.</li> </ul>
SO	<ul style="list-style-type: none"> <li>■ The master starts transmitting PDOs (RxPDOs).</li> <li>■ The DC synchronization process between the master and slave is started.</li> </ul>
PI, SI, OI	<ul style="list-style-type: none"> <li>■ The slave disables all communication functions, including the SDOs and PDOs.</li> <li>■ The slave switches to the Init state.</li> </ul>
SP, OP	<ul style="list-style-type: none"> <li>■ The slave disables the PDO function.</li> <li>■ The slave switches to the Pre-Operational state.</li> </ul>
OS	<ul style="list-style-type: none"> <li>■ The master stops transmitting PDOs (RxPDOs).</li> <li>■ The slave switches to the Safe-Operational state.</li> </ul>

# 13

## 13.2.4 PDO mapping configuration

The PDO mapping objects are allocated from OD 1600h to OD 1603h for RxPDOs and OD 1A00h to OD 1A03h for TxPDOs in the object dictionary. Each group of RxPDO and TxPDO supports updating the PDO data for up to 8 sets of 32-bit objects.

### 13.2.4.1 Default PDO mapping configuration

The following tables show the default PDO mapping configuration of the EtherCAT servo drive for data exchange. This is also defined in the XML file of the EtherCAT slave. You can modify the PDO mapping configuration according to the requirements. The fourth group of RxPDO and TxPDO is the suggested configuration for Omron controllers.

In Delta ASDA-x3-E rev0.04.xml, the first to fourth groups of PDO configuration are shown as follows:

First group of RxPDO mapping

RxPDO (OD 1600h)	Controlword (OD 6040h)	Target position (OD 607Ah)	Target velocity (OD 60FFh)	Touch probe function (OD 60B8h)
---------------------	---------------------------	-------------------------------	-------------------------------	---------------------------------------

First group of TxPDO mapping

TxPDO (OD 1A00h)	Statusword (OD 6041h)	Position actual value (OD 6064h)	Velocity actual value (OD 606Ch)	Touch probe status (OD 60B9h)
	Touch probe pos1 pos value (OD 60BAh)	Digital inputs (OD 60FDh)		

Second group of RxPDO mapping (default)

RxPDO (OD 1601h)	Controlword (OD 6040h)	Target position (OD 607Ah)	Target velocity (OD 60FFh)	Target torque (OD 6071h)
	Touch probe function (OD 60B8h)			

Second group of TxPDO mapping (default)

TxPDO (OD 1A01h)	Statusword (OD 6041h)	Position actual value (OD 6064h)	Velocity actual value (OD 606Ch)	Torque actual value (OD 6077h)
	Touch probe status (OD 60B9h)	Touch probe pos1 pos value (OD 60BAh)	Digital inputs (OD 60FDh)	

## Third group of RxPDO mapping

RxPDO (OD 1602h)	Controlword (OD 6040h)	Target position (OD 607Ah)	Target velocity (OD 60FFh)	Target torque (OD 6071h)
	Modes of operation (OD 6060h)	Touch probe function (OD 60B8h)		

## Third group of TxPDO mapping

TxPDO (OD 1A02h)	Statusword (OD 6041h)	Position actual value (OD 6064h)	Velocity actual value (OD 606Ch)	Torque actual value (OD 6077h)
	Modes of operation display (OD 6061h)	Touch probe status (OD 60B9h)	Touch probe pos1 pos value (OD 60BAh)	Digital inputs (OD 60FDh)

## Fourth group of RxPDO mapping (for Omron controllers)

RxPDO (OD 1603h)	Controlword (OD 6040h)	Target position (OD 607Ah)	Target velocity (OD 60FFh)	Target torque (OD 6071h)
	Modes of operation (OD 6060h)	Positive torque limit (OD 60E0h)	Negative torque limit (OD 60E1h)	Touch probe function (OD 60B8h)

## Fourth group of TxPDO mapping (for Omron controllers)

TxPDO (OD 1A03h)	Statusword (OD 6041h)	Position actual value (OD 6064h)	Torque actual value (OD 6077h)	Modes of operation display (OD 6061h)
	Touch probe status (OD 60B9h)	Touch probe pos1 pos value (OD 60BAh)	Error code (OD 603Fh)	Digital inputs (OD 60FDh)

# 13

### 13.2.4.2 Set PDO mapping

Take the second group of PDO configuration OD 1601h and OD 1A01h as an example, and the settings are as follows:

1. Disable the PDO configuration: set OD 1C12h sub0 to 0 (RxPDO) and OD 1C13h sub0 to 0 (TxPDO).
2. Disable the PDO mapping setting: set OD 1600h sub0 to 0 (RxPDO) and OD 1A01h sub0 to 0 (TxPDO).
3. Set OD 1601h sub1 - sub5 for the RxPDO mapping content, and set OD 1601h sub0 to 5 for the RxPDO mapping number.

Mapping parameter setting for RxPDO	Data			Description
OD 1601h sub1	6040h	00h	10h	Controlword (6040h); data length is 16-bit.
OD 1601h sub2	607Ah	00h	20h	Target position (607Ah); data length is 32-bit.
OD 1601h sub3	60FFh	00h	20h	Target velocity (60FFh); data length is 32-bit.
OD 1601h sub4	6071h	00h	10h	Target torque (6071h); data length is 16-bit.
OD 1601h sub5	60B8h	00h	10h	Touch probe function (60B8h); data length is 16-bit.
OD 1601h sub0	5			Set 5 for the RxPDO mapping number.

4. Set OD 1A01h sub1 - sub7 for the TxPDO mapping content, and set OD 1A01h sub0 to 7 for the TxPDO mapping number.

Mapping parameter setting for TxPDO	Data			Description
OD 1A01h sub1	6041h	00h	10h	Statusword (6041h); data length is 16-bit.
OD 1A01h sub2	6064h	00h	20h	Position actual value (6064h); data length is 32-bit.
OD 1A01h sub3	606Ch	00h	20h	Velocity actual value (606Ch); data length is 32-bit.
OD 1A01h sub4	6077h	00h	10h	Torque actual value (6077h); data length is 16-bit.
OD 1A01h sub5	60B9h	00h	10h	Touch probe status (60B9h); data length is 16-bit.
OD 1A01h sub6	60BAh	00h	20h	Touch probe pos1 pos value (60BAh); data length is 32-bit.
OD 1A01h sub7	60FDh	00h	20h	Digital inputs (60FDh); data length is 32-bit.
OD 1A01h sub0	7			Set 7 for the TxPDO mapping number.

5. Set the PDO mapping configuration: set OD 1C12h sub1 to 0x1601 (RxPDO) and OD 1C13h sub1 to 0x1A01 (TxPDO).
6. Enable the PDO configuration: set OD 1C12h sub0 to 1 (RxPDO) and OD 1C13h sub0 to 1 (TxPDO).

### 13.2.4.3 PDO mapping object

Real-time data transmission can be achieved with Process data objects (PDOs). There are two types of PDOs: transmit PDOs (TxPDOs) and receive PDOs (RxPDOs). This definition is from the perspective of the servo drive, for example, the TxPDO refers to the object that the servo drive sends to the controller. Set the mapping parameters as shown in the following table to use the PDOs.

Communication object	Mapping object index	Communication object	Mapping object index
RxPDO1	1600h	TxPDO1	1A00h
RxPDO2	1601h	TxPDO2	1A01h
RxPDO3	1602h	TxPDO3	1A02h
RxPDO4	1603h	TxPDO4	1A03h

The format of PDO mapping parameter is:

Bit	31	30	29	28	27	26	25	24	23	22	21	20	19	18	17	16
Bit	15	14	13	12	11	10	9	8	7	6	5	4	3	2	1	0

Bit	Function
Bit 0 - Bit 7	Object data length
Bit 8 - Bit 15	Object sub-index
Bit 16 - Bit 31	Object index

### 13.2.4.4 SDO abort codes

The abort codes are as follows:

Abort code	Description
05040001h	Client / server command is invalid or does not exist.
06010002h	Attempt to write a read-only object.
06020000h	Object does not exist in the object dictionary.
06040041h	Unable to map the object to the PDO.
06040042h	The number and length of mapped objects exceed the PDO length.
06060000h	Access failed due to hardware error (storage or restore error).
06070010h	Data type does not match; parameter length does not match.
06090011h	Sub-index does not exist.
06090030h	The written parameter value is out of range.
08000000h	General error.
080000a1h	An error occurred when reading an object from EEPROM.
080000a2h	An error occurred when writing an object to EEPROM.
080000a3h	Invalid range when accessing EEPROM.
080000a4h	EEPROM data content error occurred when accessing EEPROM.
080000a5h	The entered password is incorrect when data is written to the encryption area.
08000020h	Unable to transfer data or save data to the application.
08000021h	Unable to transfer data or save data to the application due to restrictions (storage or restore in the wrong state).
08000022h	Object is in use.

13

### 13.3 EtherCAT operation modes

This section describes the modes of operation specified by CiA DS402 when the servo is in the EtherCAT mode. The content includes basic operation settings and related object descriptions.

13

#### 13.3.1 Profile Position mode

After receiving the position command transmitted from the controller, the servo drive controls the servo motor to reach the target position.

In Profile Position (PP) mode, the controller only informs the servo drive of the target position, speed command, and acceleration / deceleration settings at the beginning. The motion planning from command triggering to the arrival of the target position is performed by the trajectory generator in the servo drive.

The following figure shows the Profile Position mode architecture of the servo drive:

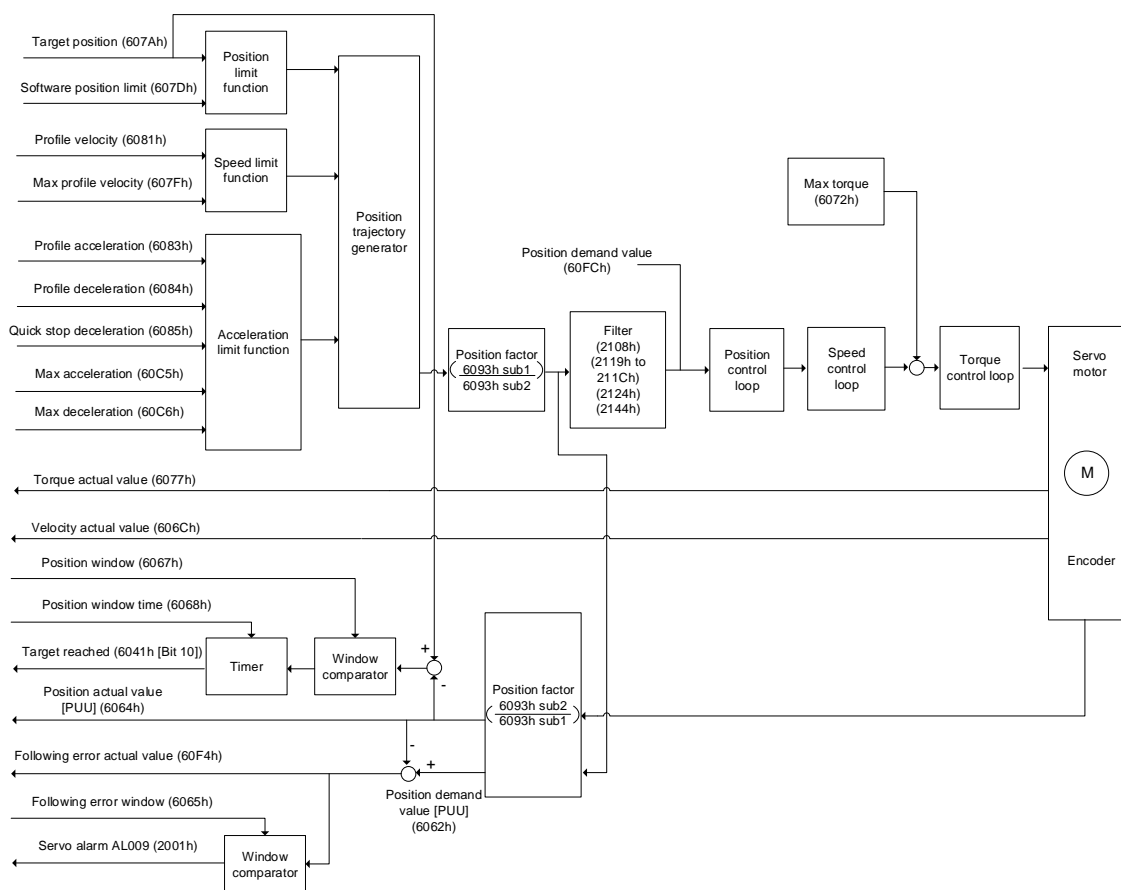



# 13

Operation steps:

1. Set OD 6060h to 01h to set the mode as Profile Position mode.
2. Set OD 607Ah for the target position (unit: PUU).
3. Set OD 6081h for the profile velocity (unit: PUU/sec).
4. Set OD 6083h for the profile acceleration (unit: ms).
5. Set OD 6084h for the profile deceleration (unit: ms).
6. Set the Controlword (OD 6040h). Follow these steps for operation. Steps 6.1 and 6.2 are to bring the servo drive's state machine into the ready state. For the description of the state machine, refer to the OD 6040h description in Section 13.4.

Step	Bit 4	Bit 3	Bit 2	Bit 1	Bit 0	Description
6.1	0	0	1	1	0	Shutdown.
6.2	0	0	1	1	1	Switch on (ready for Servo On).
6.3	0	1	1	1	1	Enable operation (Servo On).
6.4	1	1	1	1	1	Command triggering (rising-edge triggered)

7. After the servo completes the first motion command, the servo sets the target position, speed, and other conditions to execute the next motion command.
8. Set the Controlword (OD 6040h). Since the command is rising-edge triggered, switch Bit 4 to Off first and then to On.

Step	Bit 4	Bit 3	Bit 2	Bit 1	Bit 0	Description
8.1	0	1	1	1	1	Enable operation (Servo On).
8.2	1	1	1	1	1	Command triggering (rising-edge triggered)

Read the servo drive information:

1. Read OD 6064h to obtain the actual value of the motor position at present.
2. Read OD 6041h to obtain the servo drive status, including the following error and notifications for set-point acknowledge and target reached.

**Function for the command to take immediate effect**

In Profile Position mode, set the command to take effect immediately or not with OD 6040h [Bit 5].

- Set OD 6040h [Bit 5] to 0 to disable the command from taking immediate effect

If the command is not enabled to take immediate effect, when the current motion command is in execution (not yet complete), the servo continues to execute the current motion command even if a new command is triggered. The new command is acknowledged and executed only after the current command is complete.

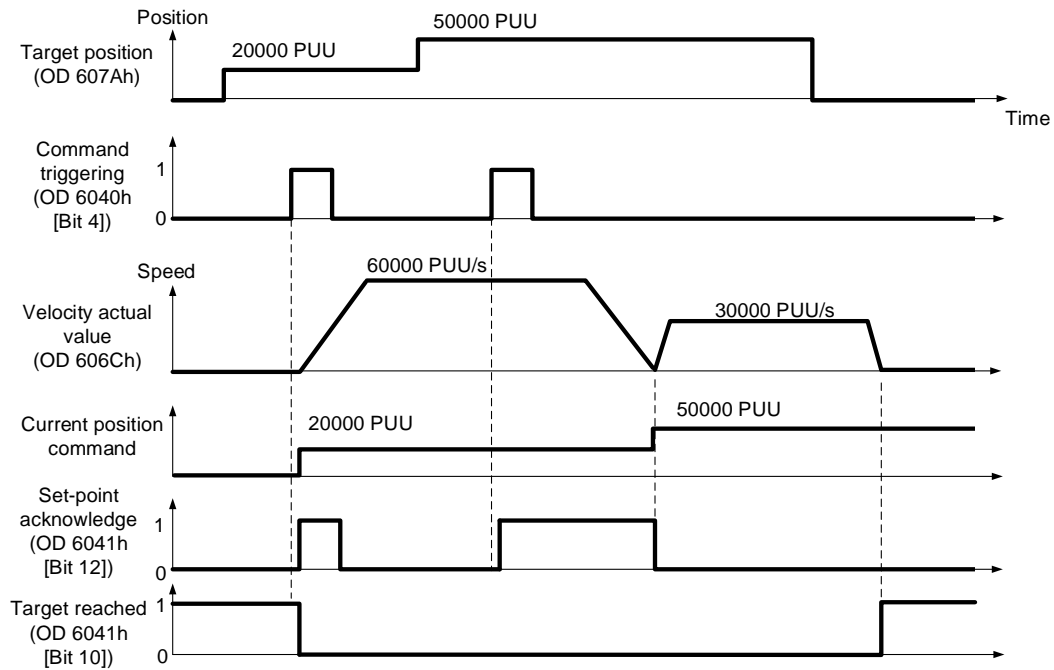

- Set OD 6040h [Bit 5] to 1 to enable the command to take immediate effect is enabled (only valid in Profile Position mode).

# 13

If the command is enabled to take immediate effect, when the current motion command is in execution (not yet complete), the servo immediately interrupts the current command and executes the new command once receiving the new triggered command.

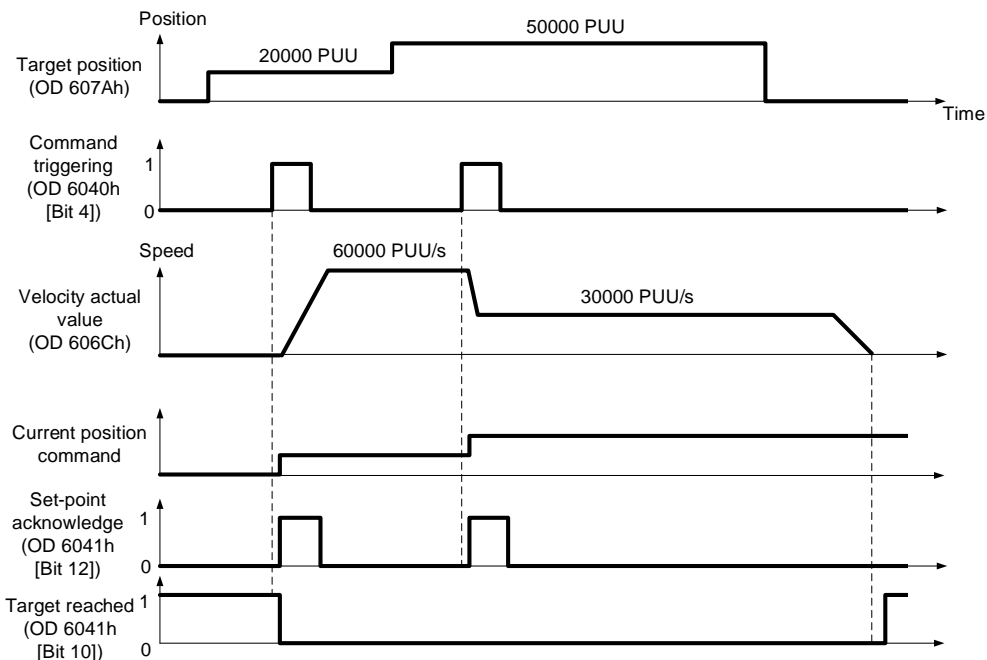

### Relevant object list

Index	Name	Data type	Access
6040h	Controlword	UNSIGNED16	RW
6041h	Statusword	UNSIGNED16	RO
6060h	Modes of operation	INTEGER8	RW
6061h	Modes of operation display	INTEGER8	RO
6062h	Position demand value [PUU]	INTEGER32	RO
6063h	Position actual internal value [Pulse]	INTEGER32	RO
6064h	Position actual value [PUU]	INTEGER32	RO
6065h	Following error window	UNSIGNED32	RW
6067h	Position window	UNSIGNED32	RW
6068h	Position window time	UNSIGNED16	RW
606Ch	Velocity actual value	INTEGER32	RO
6072h	Max torque	UNSIGNED16	RW
6077h	Torque actual value	INTEGER16	RO
607Ah	Target position	INTEGER32	RW
607Dh	Software position limit	INTEGER32	RW
607Fh	Max profile velocity	UNSIGNED32	RW
6081h	Profile velocity	UNSIGNED32	RW
6083h	Profile acceleration	UNSIGNED32	RW
6084h	Profile deceleration	UNSIGNED32	RW
6085h	Quick stop deceleration	UNSIGNED32	RW
6093h	Position factor	UNSIGNED32	RW

Index	Name	Data type	Access
60C5h	Max acceleration	UNSIGNED32	RW
60C6h	Max deceleration	UNSIGNED32	RW
60F4h	Following error actual value	INTEGER32	RO
60FCh	Position demand value	INTEGER32	RO

Note: for more details, refer to Section 13.4.3 Details of objects.

13

# 13

## 13.3.2 Profile Velocity mode

In Profile Velocity (PV) mode, the controller specifies the speed command and acceleration / deceleration conditions, and then the trajectory generator of the servo drive plans the motion path according to these conditions.

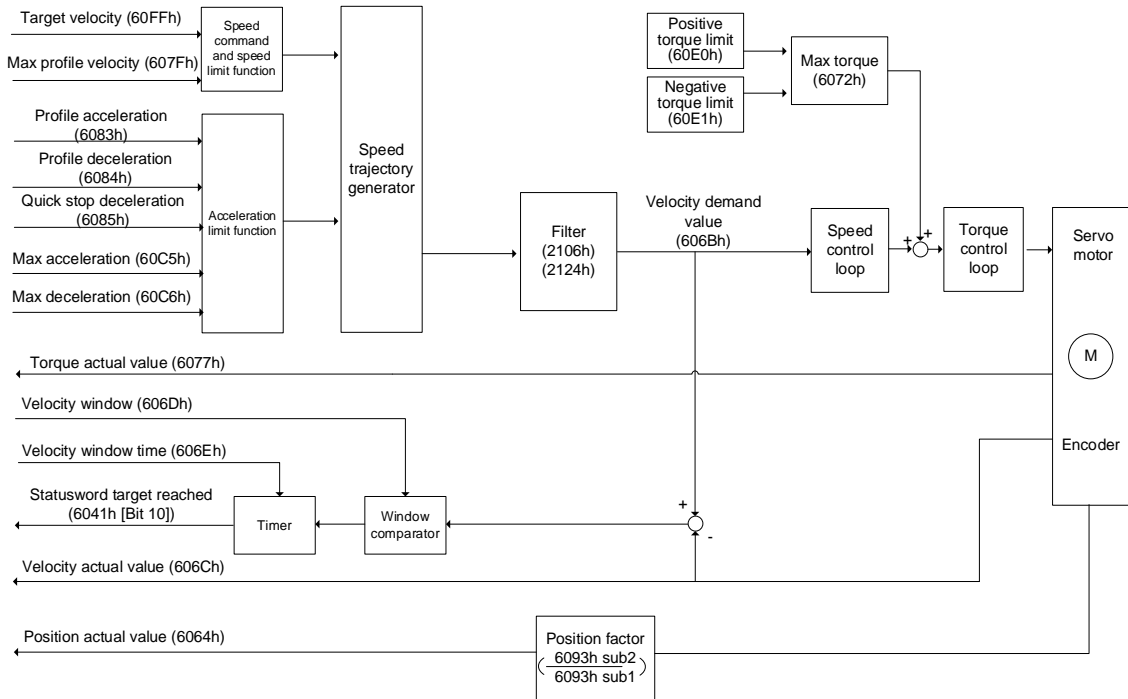

Operation steps:

1. Set OD 6060h to 03h to set the mode as Profile Velocity mode.
2. Set OD 6083h for the profile acceleration.
3. Set OD 6084h for the profile deceleration.
4. Set the target velocity (OD 60FFh) to 0. In Profile Velocity mode, the servo motor starts operating once the servo drive is switched to Servo On (Step 5). Therefore, setting the target velocity (OD 60FFh) to 0 is to ensure that the motor maintains at 0 rpm at the moment of Servo On.
5. Set the Controlword (OD 6040h). Follow these steps for operation. Steps 5.1 and 5.2 are to bring the servo drive's state machine into the ready state. For more details of the state machine, refer to the OD 6040h description in Section 13.4.

Step	Bit 4	Bit 3	Bit 2	Bit 1	Bit 0	Description
5.1	0	0	1	1	0	Shutdown.
5.2	0	0	1	1	1	Switch on (ready for Servo On).
5.3	0	1	1	1	1	Enable operation (Servo On).

6. Set OD 60FFh for the target velocity.

Read the servo drive information:

1. Read OD 6041h to obtain the servo drive status.
2. Read OD 606Ch to obtain the current velocity actual value.

13

Relevant object list

Index	Name	Data type	Access
6040h	Controlword	UNSIGNED16	RW
6041h	Statusword	UNSIGNED16	RO
6060h	Modes of operation	INTEGER8	RW
6061h	Modes of operation display	INTEGER8	RO
6064h	Position actual value [PUU]	INTEGER32	RO
606Bh	Velocity demand value	INTEGER32	RO
606Ch	Velocity actual value	INTEGER32	RO
606Dh	Velocity window	UNSIGNED16	RW
606Eh	Velocity window time	UNSIGNED16	RW
606Fh	Velocity threshold	UNSIGNED16	RW
6072h	Max torque	UNSIGNED16	RW
6077h	Torque actual value	INTEGER16	RO
607Fh	Max profile velocity	UNSIGNED32	RW
6083h	Profile acceleration	UNSIGNED32	RW
6084h	Profile deceleration	UNSIGNED32	RW
6085h	Quick stop deceleration	UNSIGNED32	RW
6093h	Position factor	UNSIGNED32	RW
60C5h	Max acceleration	UNSIGNED32	RW
60C6h	Max deceleration	UNSIGNED32	RW
60E0h	Positive torque limit	UNSIGNED16	RW
60E1h	Negative torque limit	UNSIGNED16	RW
60FFh	Target velocity	INTEGER32	RW

Note: for more details, refer to Section 13.4.3 Details of objects.

# 13

## 13.3.3 Profile Torque mode

In Profile Torque (PT) mode, the controller specifies the torque command and filtering conditions, and then the trajectory generator of the servo drive plans the torque slope according to these conditions.

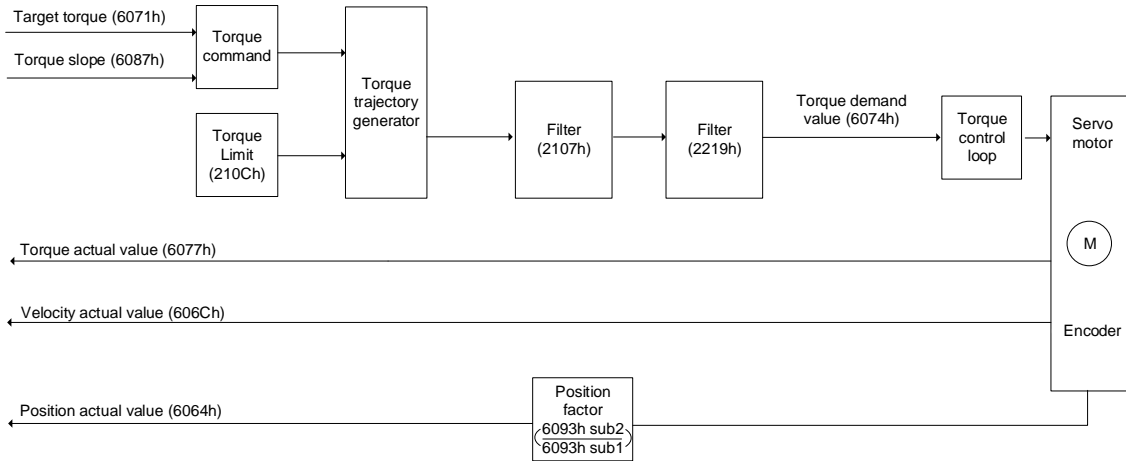

Operation steps:

1. Set OD 6060h to 04h to set the mode as Profile Torque mode.
2. Set OD 6087h for the torque slope.
3. Set the target torque (OD 6071h) to 0. In Profile Torque mode, the servo target torque takes effect once the servo drive is switched to Servo On (Step 4). Therefore, set the target torque (OD 6071h) to 0 for safety reasons.
4. Set the Controlword (OD 6040h). Follow these steps for operation. Steps 4.1 and 4.2 are to bring the servo drive's state machine into the ready state. For more details of the state machine, refer to the OD 6040h description in Section 13.4.

Step	Bit 4	Bit 3	Bit 2	Bit 1	Bit 0	Description
4.1	0	0	1	1	0	Shutdown.
4.2	0	0	1	1	1	Switch on (ready for Servo On).
4.3	0	1	1	1	1	Enable operation (Servo On).

5. Set OD 6071h for the target torque.

Read the servo drive information:

1. Read OD 6041h to obtain the servo drive status.
2. Read OD 6077h to obtain the current torque actual value.

13

Relevant object list

Index	Name	Data type	Access
6040h	Controlword	UNSIGNED16	RW
6041h	Statusword	UNSIGNED16	RO
6060h	Modes of operation	INTEGER8	RW
6061h	Modes of operation display	INTEGER8	RO
6064h	Position actual value [PUU]	INTEGER32	RO
606Ch	Velocity actual value	INTEGER32	RO
6071h	Target torque	INTEGER16	RW
6074h	Torque demand value	INTEGER16	RO
6075h	Motor rated current	UNSIGNED32	RO
6077h	Torque actual value	INTEGER16	RO
6078h	Current actual value	INTEGER16	RO
6087h	Torque slope	UNSIGNED32	RW
6093h	Position factor	UNSIGNED32	RW

Note: for more details, refer to Section 13.4.3 Details of objects.



# 13

## 13.3.4 Homing mode

After homing is complete, the position system of the servo drive is established and the drive can start executing the position command issued by the controller. The Delta A3 servo drive offers 39 homing methods, including homing on the home switch, positive or negative limit, motor Z pulse, and hard stop.

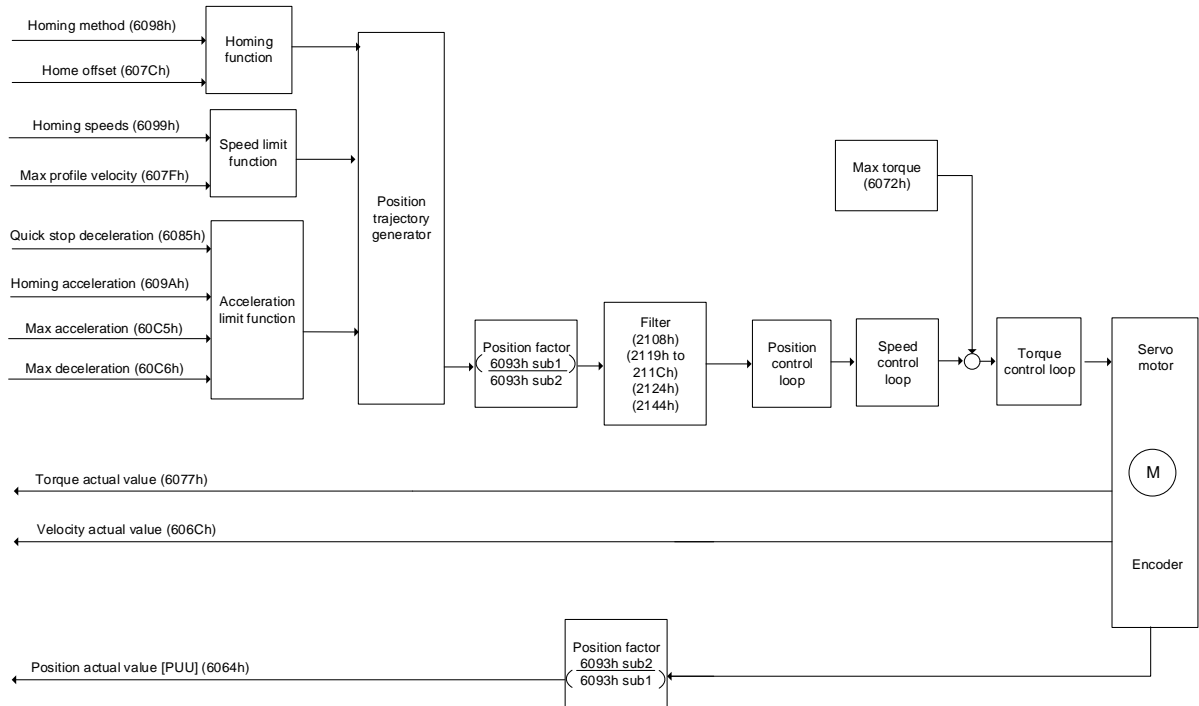

Operation steps:

1. Set OD 6060h to 06h to set the mode as Homing mode.
2. Set OD 607Ch for the home offset.
3. Set OD 6098h for the homing method.
4. Set OD 6099h sub1 for the speed when searching for the home switch.
5. Set OD 6099h sub2 for the speed when searching for the Z pulse.
6. Set OD 609Ah for the homing acceleration.
7. Set the Controlword (OD 6040h). Follow these steps for operation. Steps 7.1 and 7.2 are to bring the servo drive's state machine into the ready state. For more details of the state machine, refer to the OD 6040h description in Section 13.4.

Step	Bit 4	Bit 3	Bit 2	Bit 1	Bit 0	Description
7.1	0	0	1	1	0	Shutdown.
7.2	0	0	1	1	1	Switch on (ready for Servo On).
7.3	0	1	1	1	1	Enable operation (Servo On).
7.4	1	1	1	1	1	Homing (rising-edge triggered).

Read the servo drive information:

1. Read OD 6041h to obtain the servo drive status.
2. Read OD 6064h to obtain the actual value of the motor position at present.

13

Relevant object list

Index	Name	Data type	Access
6040h	Controlword	UNSIGNED16	RW
6041h	Statusword	UNSIGNED16	RO
6060h	Modes of operation	INTEGER8	RW
6061h	Modes of operation display	INTEGER8	RO
6064h	Position actual value [PUU]	INTEGER32	RO
606Ch	Velocity actual value	INTEGER32	RO
6072h	Max torque	UNSIGNED16	RW
607Ch	Home offset	INTEGER32	RW
607Fh	Max profile velocity	UNSIGNED32	RW
6085h	Quick stop deceleration	UNSIGNED32	RW
6093h	Position factor	UNSIGNED32	RW
6098h	Homing method	INTEGER8	RW
6099h	Homing speeds	UNSIGNED32	RW
609Ah	Homing acceleration	UNSIGNED32	RW
60C5h	Max acceleration	UNSIGNED32	RW
60C6h	Max deceleration	UNSIGNED32	RW

Note: for more details, refer to Section 13.4.3 Details of objects.

# 13

## 13.3.5 Cyclic Synchronous Position mode

The controller plans the path in Cyclic Synchronous Position (CSP) mode and transmits PDOs to the servo drive periodically. In this mode, when the controller transmits each PDO, it simultaneously transmits the target position and controlword data to the servo drive. The velocity offset and torque offset can be used as the velocity and torque feed forward control setting.

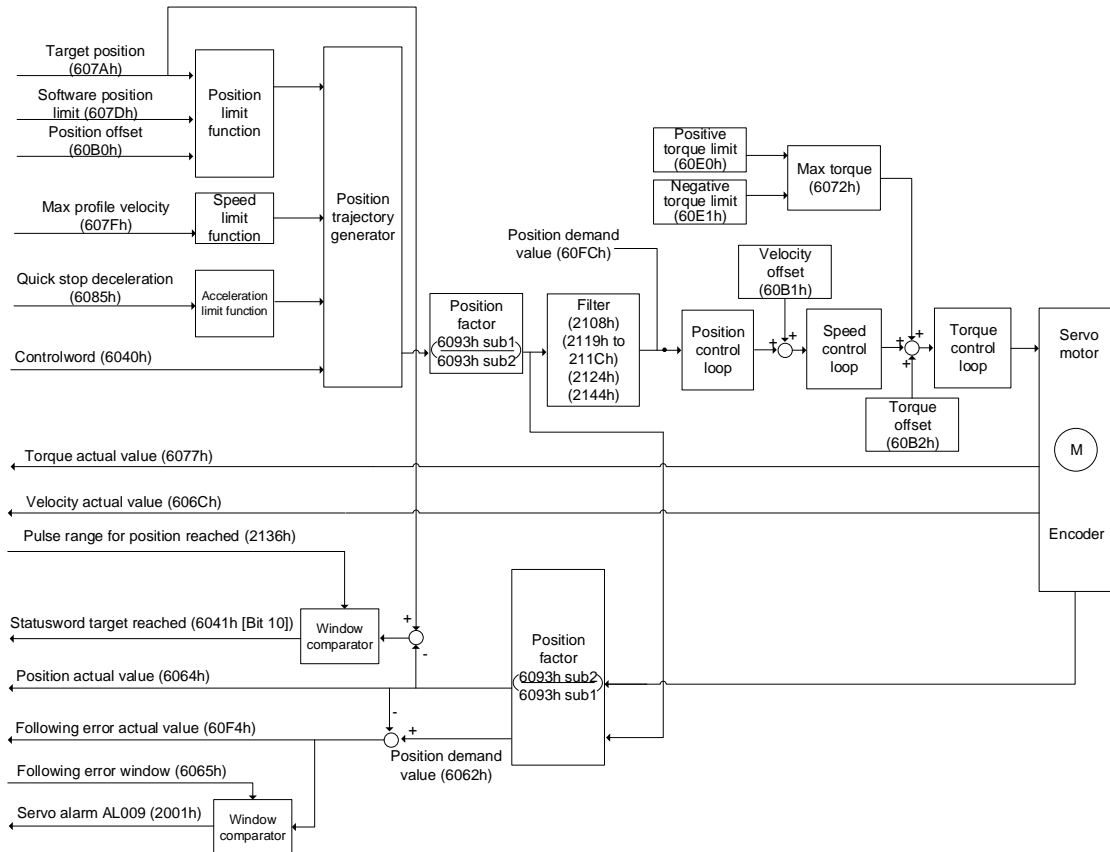

Operation steps:

1. Set OD 6060h to 08h to set the mode as Cyclic Synchronous Position mode.
2. Set OD 607Ah for the target position (unit: PUU).
3. Set the Controlword (OD 6040h). Follow these steps for operation. Steps 3.1 and 3.2 are to bring the servo drive's state machine into the ready state. For the description of the state machine, refer to the OD 6040h description in Section 13.4.

Step	Bit 4	Bit 3	Bit 2	Bit 1	Bit 0	Description
3.1	0	0	1	1	0	Shutdown.
3.2	0	0	1	1	1	Switch on (ready for Servo On).
3.3	0	1	1	1	1	Enable operation (Servo On).

## Relevant object list

Index	Name	Data type	Access
6040h	Controlword	UNSIGNED16	RW
6041h	Statusword	UNSIGNED16	RO
6060h	Modes of operation	INTEGER8	RW
6061h	Modes of operation display	INTEGER8	RO
6062h	Position demand value [PUU]	INTEGER32	RO
6064h	Position actual value [PUU]	INTEGER32	RO
6065h	Following error window	UNSIGNED32	RW
606Ch	Velocity actual value	INTEGER32	RO
6072h	Max torque	UNSIGNED16	RW
6077h	Torque actual value	INTEGER16	RO
607Ah	Target position	INTEGER32	RW
607Dh	Software position limit	INTEGER32	RW
607Fh	Max profile velocity	UNSIGNED32	RW
6085h	Quick stop deceleration	UNSIGNED32	RW
6093h	Position factor	UNSIGNED32	RW
60B0h	Position offset	INTEGER32	RW
60B1h	Velocity offset	INTEGER32	RW
60B2h	Torque offset	INTEGER16	RW
60E0h	Positive torque limit	UNSIGNED16	RW
60E1h	Negative torque limit	UNSIGNED16	RW
60F4h	Following error actual value	INTEGER32	RO
60FCh	Position demand value	INTEGER32	RO

Note: for more details, refer to Section 13.4.3 Details of objects.

# 13

## 13.3.6 Cyclic Synchronous Velocity mode

The controller plans the speed in Cyclic Synchronous Velocity (CSV) mode and transmits PDOs to the servo drive periodically. In this mode, when the controller transmits each PDO, it simultaneously transmits the target velocity and controlword data to the servo drive. The velocity offset and torque offset can be used as the velocity and torque feed forward control setting.

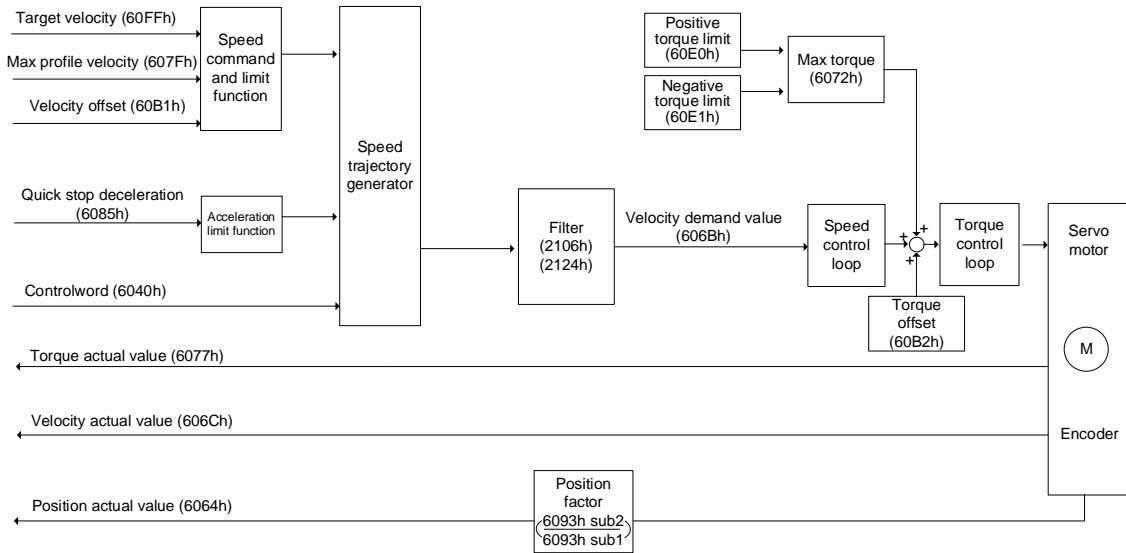

Operation steps:

1. Set OD 6060h to 09h to set the mode as Cyclic Synchronous Velocity mode.
2. Set the target velocity (OD 60FFh) to 0. In Cyclic Synchronous Velocity mode, the servo motor starts operating once the servo drive is switched to Servo On (Step 3). Therefore, setting the target velocity (OD 60FFh) to 0 is to ensure that the motor maintains at 0 rpm at the moment of Servo On.
3. Set the Controlword (OD 6040h). Follow these steps for operation. Steps 3.1 and 3.2 are to bring the servo drive's state machine into the ready state. For the description of the state machine, refer to the OD 6040h description in Section 13.4.

Step	Bit 4	Bit 3	Bit 2	Bit 1	Bit 0	Description
3.1	0	0	1	1	0	Shutdown.
3.2	0	0	1	1	1	Switch on (ready for Servo On).
3.3	0	1	1	1	1	Enable operation (Servo On).

4. Set OD 60FFh for the target velocity.

## Relevant object list

Index	Name	Data type	Access
6040h	Controlword	UNSIGNED16	RW
6041h	Statusword	UNSIGNED16	RO
6060h	Modes of operation	INTEGER8	RW
6061h	Modes of operation display	INTEGER8	RO
6064h	Position actual value [PUU]	INTEGER32	RO
606Bh	Velocity demand value	INTEGER32	RO
606Ch	Velocity actual value	INTEGER32	RO
6072h	Max torque	UNSIGNED16	RW
6077h	Torque actual value	INTEGER16	RO
607Fh	Max profile velocity	UNSIGNED32	RW
6085h	Quick stop deceleration	UNSIGNED32	RW
6093h	Position factor	UNSIGNED32	RW
60B1h	Velocity offset	INTEGER32	RW
60B2h	Torque offset	INTEGER16	RW
60E0h	Positive torque limit	UNSIGNED16	RW
60E1h	Negative torque limit	UNSIGNED16	RW
60FFh	Target velocity	INTEGER32	RW

Note: for more details, refer to Section 13.4.3 Details of objects.

# 13

## 13.3.7 Cyclic Synchronous Torque mode

The controller plans the torque in Cyclic Synchronous Torque (CST) mode and transmits PDOs to the servo drive periodically. In this mode, when the controller transmits each PDO, it simultaneously transmits the target torque and controlword data to the servo drive. The torque offset can be used as the torque feed forward control setting.

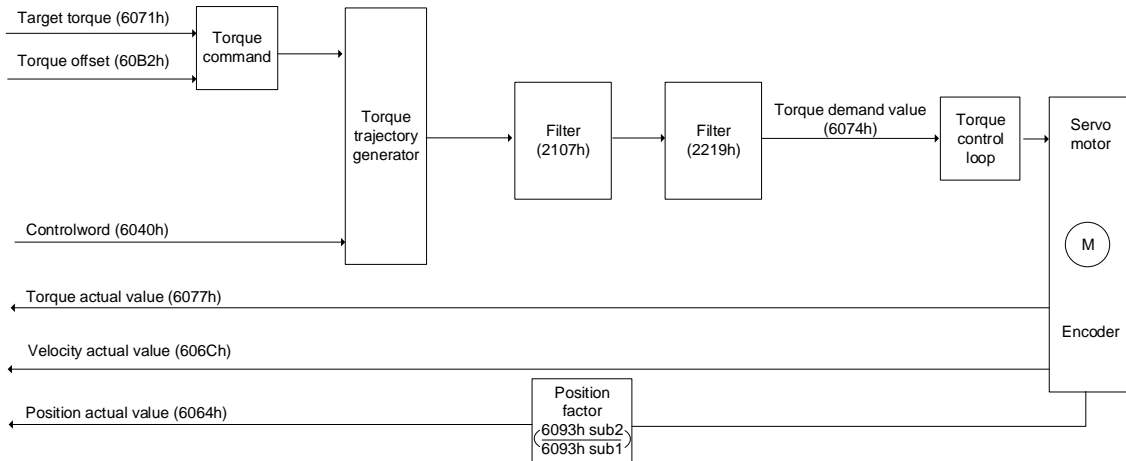

Operation steps:

1. Set OD 6060h to 0Ah to set the mode as Cyclic Synchronous Torque mode.
2. Set the target torque (OD 6071h) to 0. In Cyclic Synchronous Torque mode, the servo target torque takes effect once the servo drive is switched to Servo On (Step 3). Therefore, set the target torque (OD 6071h) to 0 for safety reasons.
3. Set the Controlword (OD 6040h). Follow these steps for operation. Steps 3.1 and 3.2 are to bring the servo drive's state machine into the ready state. For more details of the state machine, refer to the OD 6040h description in Section 13.4.

Step	Bit 4	Bit 3	Bit 2	Bit 1	Bit 0	Description
3.1	0	0	1	1	0	Shutdown.
3.2	0	0	1	1	1	Switch on (ready for Servo On).
3.3	0	1	1	1	1	Enable operation (Servo On).

4. Set OD 6071h for the target torque.

## Relevant object list

Index	Name	Data type	Access
6040h	Controlword	UNSIGNED16	RW
6041h	Statusword	UNSIGNED16	RO
6060h	Modes of operation	INTEGER8	RW
6061h	Modes of operation display	INTEGER8	RO
6064h	Position actual value [PUU]	INTEGER32	RO
606Ch	Velocity actual value	INTEGER32	RO
6071h	Target torque	INTEGER16	RW
6074h	Torque demand value	INTEGER16	RO
6077h	Torque actual value	INTEGER16	RO
6093h	Position factor	UNSIGNED32	RW
60B2h	Torque offset	INTEGER16	RW

Note: for more details, refer to Section 13.4.3 Details of objects.



# 13

### 13.3.8 Touch Probe function and Touch Probe status

The Touch Probe function can be triggered by high-speed digital inputs (only DI1 and DI2, with the hardware response time up to 5  $\mu$ s) or by the motor Z pulse. This function is used for high-speed measurement or packaging applications.

If the capture source is the motor Z pulse or DI of CN1, note the following:

1. When the capture source is set to the motor Z pulse, you can only use Touch Probe 1. Regardless of the settings of OD 60B8h [Bit 4] and [Bit 5], the command is rising-edge triggered and the data is stored in OD 60BAh.
2. When the capture source is set to the DI of CN1, the previously set function code for the DI is changed to 0x0100 so one DI does not have two functions.

Set the Touch Probe function with OD 60B8h. The definition of each bit is as follows.

Bit	15	14	13	12	11	10	9	8	7	6	5	4	3	2	1	0
-----	----	----	----	----	----	----	---	---	---	---	---	---	---	---	---	---

Bit	Function	Description
Bit 0	Touch Probe 1 switch	0: disable Touch Probe 1. 1: enable Touch Probe 1.
Bit 1	Touch Probe 1 number of capturing times	0: capture one time. If the Touch Probe 1 signal is set to be both rising-edge and falling-edge triggered, the data is captured once for each triggering. 1: capture multiple times.
Bit 2	Touch Probe 1 capture source	0: DI1 of CN1 1: motor Z pulse
Bit 3	Reserved	-
Bit 4	Rising-edge trigger action of Touch Probe 1	0: N/A 1: start capturing when the Touch Probe 1 signal is rising-edge triggered and store the data in OD 60BAh.
Bit 5	Falling-edge trigger action of Touch Probe 1	0: N/A 1: start capturing when the Touch Probe 1 signal is falling-edge triggered and store the data in OD 60BBh.
Bit 6 - Bit 7	Reserved	-
Bit 8	Touch Probe 2 switch	0: disable Touch Probe 2. 1: enable Touch Probe 2.
Bit 9	Touch Probe 2 number of capturing times	0: capture one time. If the Touch Probe 2 signal is set to be both rising-edge and falling-edge triggered, the data is captured once for each triggering. 1: capture multiple times.
Bit 10	Touch Probe 2 capture source	0: DI2 of CN1
Bit 11	Reserved	-
Bit 12	Rising-edge trigger action of Touch Probe 2	0: N/A 1: start capturing when the Touch Probe 2 signal is rising-edge triggered and store the data in OD 60BCh.

Bit	Function	Description
Bit 13	Falling-edge trigger action of Touch Probe 2	0: N/A 1: start capturing when the Touch Probe 2 signal is falling-edge triggered and store the data in OD 60BDh.
Bit 14 - Bit 15	Reserved	-

13

You can access the Touch Probe status with OD 60B9h. The definition of each bit is as follows.

Bit	15	14	13	12	11	10	9	8	7	6	5	4	3	2	1	0
-----	----	----	----	----	----	----	---	---	---	---	---	---	---	---	---	---

Bit	Function	Description
Bit 0	Touch Probe 1 function status	0: Touch Probe 1 disabled. 1: Touch Probe 1 enabled.
Bit 1	Touch Probe 1 rising-edge capture	0: capturing is not triggered. 1: the Touch Probe 1 signal is rising-edge triggered and the data is successfully captured.
Bit 2	Touch Probe 1 falling-edge capture	0: capturing is not triggered. 1: the Touch Probe 1 signal is falling-edge triggered and the data is successfully captured.
Bit 3 - Bit 5	Reserved	-
Bit 6	Touch Probe 1 capture source	0: DI1 of CN1 1: motor Z pulse
Bit 7	Touch Probe 1 signal for capturing multiple times (Available when the function of OD 60B8h [Bit 1] Number of capturing times is enabled)	The status is reversed once the capturing succeeds. Refer to the timing diagram in Example 3.
Bit 8	Touch Probe 2 function status	0: Touch Probe 2 disabled. 1: Touch Probe 2 enabled.
Bit 9	Touch Probe 2 rising-edge capture	0: capturing is not triggered 1: the Touch Probe 2 signal is rising-edge triggered and the data is successfully captured.
Bit 10	Touch Probe 2 falling-edge capture	0: capturing is not triggered 1: the Touch Probe 2 signal is falling-edge triggered and the data is successfully captured.
Bit 11 - Bit 13	Reserved	-
Bit 14	Touch Probe 2 capture source	0: DI2 of CN1
Bit 15	Touch Probe 2 signal for capturing multiple times (Available when the function of OD 60B8h [Bit 9] Number of capturing times is enabled)	The status is reversed once the capturing succeeds.

# 13

Example 1: the following is the timing diagram for the Touch Probe 1 function. In this example, the Touch Probe 1 function is triggered by the external DI. When OD 60B8h [Bit 1] is set to 0 and OD 60B8h [Bit 4] & [Bit 5] are set to 1, the Touch Probe 1 signal is both rising-edge and falling-edge triggered, and the data is captured once for each triggering.

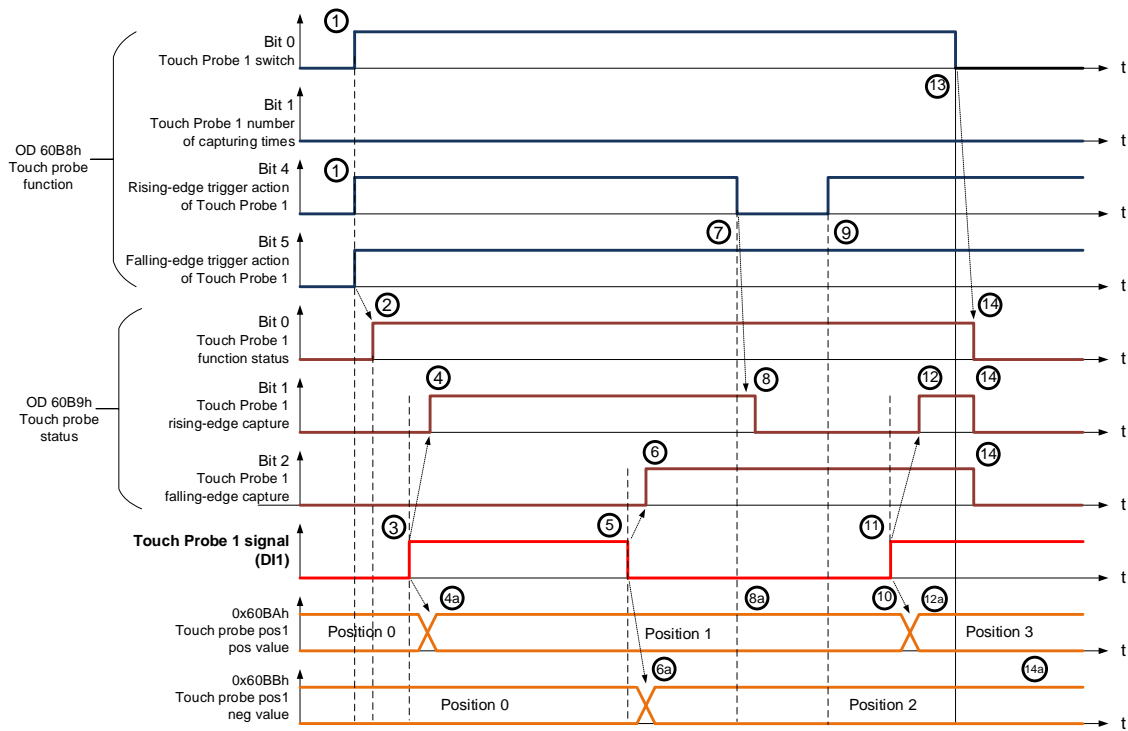

Status	Function	Description
(1)	OD 60B8h [Bit 0] = 1	Enable Touch Probe 1.
	OD 60B8h [Bit 1] = 0	Capture one time.
	OD 60B8h [Bit 4] = 1	Start capturing when the Touch Probe 1 signal is rising-edge triggered.
	OD 60B8h [Bit 5] = 1	Start capturing when the Touch Probe 1 signal is falling-edge triggered.
(2)	OD 60B9h [Bit 0] = 1	Touch Probe status: Touch Probe 1 function enabled.
(3)	-	Touch Probe 1 is rising-edge triggered by external signal.
(4)	OD 60B9h [Bit 1] = 1	Touch Probe status: Touch Probe 1 is rising-edge triggered and the data is successfully captured.
(4a)	OD 60BAh	Store the captured data in OD 60BAh when the Touch Probe 1 signal is rising-edge triggered.
(5)	-	Touch Probe 1 is falling-edge triggered by external signal.
(6)	OD 60B9h [Bit 2] = 1	Touch Probe status: Touch Probe 1 signal is falling-edge triggered and the data is successfully captured.
(6a)	OD 60BBh	Store the captured data in OD 60BBh when the Touch Probe 1 signal is falling-edge triggered.
(7)	OD 60B8h [Bit 4] = 0	Disable the rising-edge trigger action of Touch Probe 1.
(8)	OD 60B9h [Bit 1] = 0	Touch Probe status: reset the rising-edge capture status to non-triggered.
(8a)	OD 60BAh	Data at the rising-edge remains the same.
(9)	OD 60B8h [Bit 4] = 1	Start capturing when the Touch Probe 1 signal is rising-edge triggered.

Status	Function	Description
(10)	OD 60BAh	Data at the rising-edge remains the same.
(11)	-	Touch Probe 1 is rising-edge triggered by external signal.
(12)	OD 60B9h [Bit 1] = 1	Touch Probe status: Touch Probe 1 signal is rising-edge triggered and the data is successfully captured.
(12a)	OD 60BAh	Store the captured data in OD 60BAh when the Touch Probe 1 signal is rising-edge triggered.
(13)	OD 60B8h [Bit 0] = 0	Disable Touch Probe 1.
(14)	OD 60B9h [Bit 0] = 0 OD 60B9h [Bit 1] = 0 OD 60B9h [Bit 2] = 0	Reset Touch Probe 1 status.
(14a)	OD 60BAh	The previously captured data remains the same.

Example 2: the following is the timing diagram for the Touch Probe 1 function. In this example, the Touch Probe 1 function is triggered by the motor Z pulse. The data is captured only once when the Touch Probe 1 signal is rising-edge triggered.

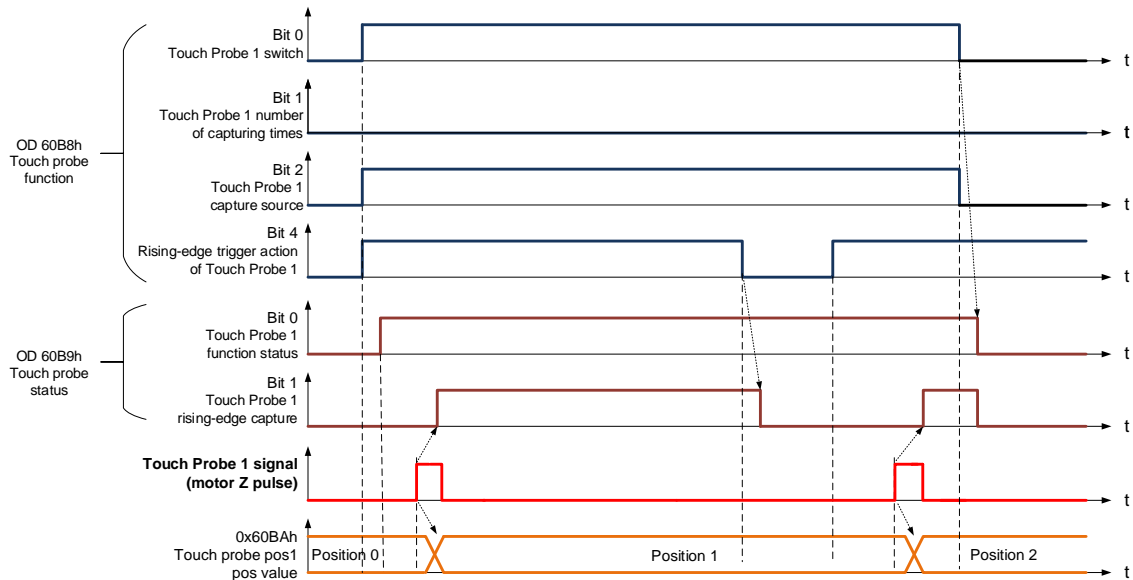

# 13

Example 3: the following is the timing diagram for the Touch Probe 1 function. In this example, the Touch Probe 1 function is triggered by the motor Z pulse. The data is captured **multiple times** when the Touch Probe 1 signal is rising-edge triggered.

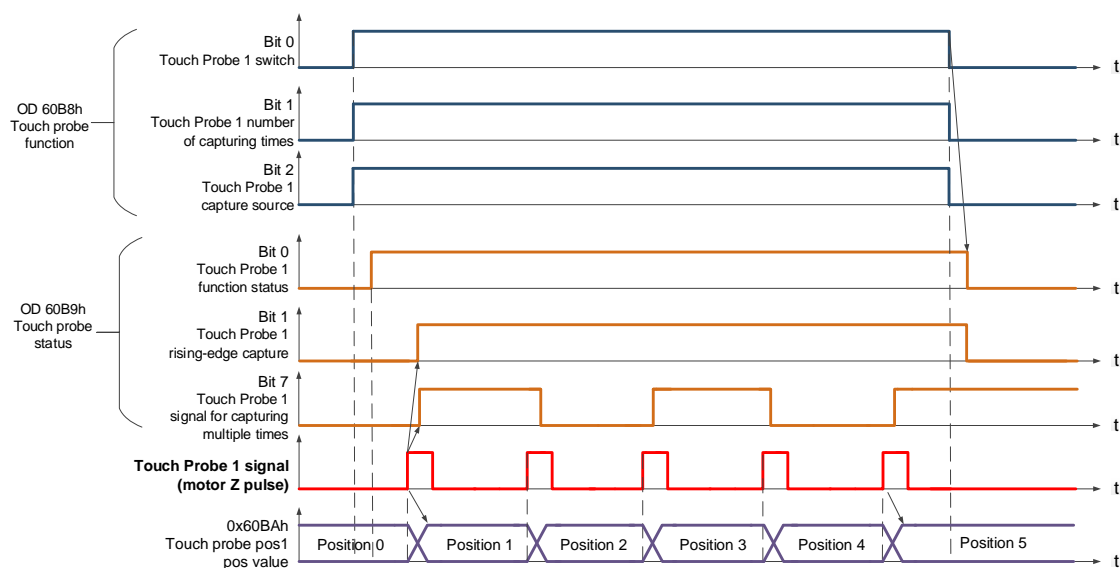

Relevant object list

Index	Name	Data type	Access
60B8h	Touch probe function	UNSIGNED16	RW
60B9h	Touch probe status	UNSIGNED16	RO
60BAh	Touch probe pos1 pos value	INTEGER32	RO
60BBh	Touch probe pos1 neg value	INTEGER32	RO
60BCh	Touch probe pos2 pos value	INTEGER32	RO
60BDh	Touch probe pos2 neg value	INTEGER32	RO

Note: for more details, refer to Section 13.4.3 Details of objects.

## 13.4 Object dictionary

This section details the EtherCAT objects supported by the servo. The contents include object index, name, data type, data length, and read / write permissions (access).

### 13.4.1 Specifications for objects

#### Object code

Object code	Description
VAR	A single value, such as an UNSIGNED8, Boolean, float, and INTEGER16.
ARRAY	An object of multiple data fields consisting of multiple variables of the same data type, such as an UNSIGNED16 array. The sub-index 0 data type is UNSIGNED8, so it is not an ARRAY data.
RECORD	An object of multiple data fields consisting of multiple variables of different data types. The sub-index 0 data type is UNSIGNED8, so it is not a RECORD data.

#### Data type

Refer to CANopen DS301.

## 13.4.2 List of objects

### OD 1XXXh communication object group

Index	Object code	Name	Data type	Access
1000h	VAR	Device type	UNSIGNED32	RO
1001h	VAR	Error register	UNSIGNED8	RO
1003h	ARRAY	Pre-defined error field	UNSIGNED32	RW
1006h	VAR	Communication cycle period	UNSIGNED32	RW
1600h - 1603h	RECORD	Receive PDO mapping parameter	UNSIGNED32	RW
1A00h - 1A03h	RECORD	Transmit PDO mapping parameter	UNSIGNED32	RW
1C12h	ARRAY	RxPDO assign	UNSIGNED16	RW
1C13h	ARRAY	TxPDO assign	UNSIGNED16	RW

Note: only 1001h can be mapped to PDO.

### OD 2XXXh servo parameter group

Index	Object code	Name	Data type	Access	Mappable
2XXXh	VAR	Parameter Mapping	INTEGER16/32	RW	Y

### OD 6XXXh communication object group

Index	Object code	Name	Data type	Access	Mappable
603Fh	VAR	Error code	UNSIGNED16	RO	Y
6040h	VAR	Controlword	UNSIGNED16	RW	Y
6041h	VAR	Statusword	UNSIGNED16	RO	Y
605Bh	VAR	Shutdown option code	INTEGER16	RW	Y
6060h	VAR	Modes of operation	INTEGER8	RW	Y
6061h	VAR	Modes of operation display	INTEGER8	RO	Y
6062h	VAR	Position demand value [PUU]	INTEGER32	RO	Y
6063h	VAR	Position actual internal value [Pulse]	INTEGER32	RO	Y
6064h	VAR	Position actual value [PUU]	INTEGER32	RO	Y
6065h	VAR	Following error window	UNSIGNED32	RW	Y
6067h	VAR	Position window	UNSIGNED32	RW	Y
6068h	VAR	Position window time	UNSIGNED16	RW	Y
606Bh	VAR	Velocity demand value	INTEGER32	RO	Y
606Ch	VAR	Velocity actual value	INTEGER32	RO	Y
606Dh	VAR	Velocity window	UNSIGNED16	RW	Y
606Eh	VAR	Velocity window time	UNSIGNED16	RW	Y
606Fh	VAR	Velocity threshold	UNSIGNED16	RW	Y
6071h	VAR	Target torque	INTEGER16	RW	Y
6072h	VAR	Max torque	UNSIGNED16	RW	Y
6074h	VAR	Torque demand value	INTEGER16	RO	Y
6075h	VAR	Motor rated current	UNSIGNED32	RO	Y
6076h	VAR	Motor rated torque	UNSIGNED32	RO	Y
6077h	VAR	Torque actual value	INTEGER16	RO	Y
6078h	VAR	Current actual value	INTEGER16	RO	Y
607Ah	VAR	Target position	INTEGER32	RW	Y
607Ch	VAR	Home offset	INTEGER32	RW	Y

Index	Object code	Name	Data type	Access	Mappable
607Dh	ARRAY	Software position limit	INTEGER32	RW	Y
607Fh	VAR	Max profile velocity	UNSIGNED32	RW	Y
6080h	VAR	Max motor speed	UNSIGNED32	RW	Y
6081h	VAR	Profile velocity	UNSIGNED32	RW	Y
6083h	VAR	Profile acceleration	UNSIGNED32	RW	Y
6084h	VAR	Profile deceleration	UNSIGNED32	RW	Y
6085h	VAR	Quick stop deceleration	UNSIGNED32	RW	Y
6086h	VAR	Motion profile type	INTEGER16	RO	Y
6087h	VAR	Torque slope	UNSIGNED32	RW	Y
6093h	ARRAY	Position factor	UNSIGNED32	RW	Y
6098h	VAR	Homing method	INTEGER8	RW	Y
6099h	ARRAY	Homing speeds	UNSIGNED32	RW	Y
609Ah	VAR	Homing acceleration	UNSIGNED32	RW	Y
60B0h	VAR	Position offset	INTEGER32	RW	Y
60B1h	VAR	Velocity offset	INTEGER32	RW	Y
60B2h	VAR	Torque offset	INTEGER16	RW	Y
60B8h	VAR	Touch probe function	UNSIGNED16	RW	Y
60B9h	VAR	Touch probe status	UNSIGNED16	RO	Y
60BAh	VAR	Touch probe pos1 pos value	INTEGER32	RO	Y
60BBh	VAR	Touch probe pos1 neg value	INTEGER32	RO	Y
60BCh	VAR	Touch probe pos2 pos value	INTEGER32	RO	Y
60BDh	VAR	Touch probe pos2 neg value	INTEGER32	RO	Y
60C5h	VAR	Max acceleration	UNSIGNED32	RW	Y
60C6h	VAR	Max deceleration	UNSIGNED32	RW	Y
60E0h	VAR	Positive torque limit	UNSIGNED16	RW	Y
60E1h	VAR	Negative torque limit	UNSIGNED16	RW	Y
60F4h	VAR	Following error actual value	INTEGER32	RO	Y
60FCh	VAR	Position demand value	INTEGER32	RO	Y
60FDh	VAR	Digital inputs	UNSIGNED32	RO	Y
60FEh	ARRAY	Digital outputs	UNSIGNED32	RW	Y
60FFh	VAR	Target velocity	INTEGER32	RW	Y
6502h	VAR	Supported drive modes	UNSIGNED32	RO	Y



### 13.4.3 Details of objects

#### 13.4.3.1 OD 1XXXh communication object group

13

Object 1000h: Device type

Index	1000h
Name	Device type
Object code	VAR
Data type	UNSIGNED32
Access	RO
PDO mapping	No
Setting range	UNSIGNED32

Format of this object: (High word h) DCBA; (Low word L) UZYX

A	Bit 16 - Bit 31 Model type	X	Bit 0 - Bit 15 Device profile number
B		Y	
C		Z	
D		U	

Definitions are as follows:

- UZYX: device profile number (servo drive: 0192)
- DCBA: model type

DCBA	Model type
0402	A2
0602	M
0702	A3
0B02	B3
1002	E3

Object 1001h: Error register

Index	1001h
Name	Error register
Object code	VAR
Data type	UNSIGNED8
Access	RO
PDO mapping	Yes
Setting range	UNSIGNED8
Default	0

Object function:

The bits and corresponding functions are as follows:

Bit	7	6	5	4	3	2	1	0
-----	---	---	---	---	---	---	---	---

Bit	Function
Bit 0	Generic error
Bit 1	Current
Bit 2	Voltage
Bit 3	Temperature
Bit 4	Communication error
Bit 5 - Bit 7	Reserved

Object 1003h: Pre-defined error field

Index	1003h
Name	Pre-defined error field
Object code	ARRAY
Data type	UNSIGNED32
Access	RW
PDO mapping	No

Sub-index	0
Description	Number of errors
Data type	UNSIGNED8
Access	RW
PDO mapping	No
Setting range	0 - 5
Default	0

Sub-index	1 - 5
Description	Standard error field
Data type	UNSIGNED32
Access	RO
PDO mapping	No
Setting range	UNSIGNED32
Default	0

# 13

Format of this object: (High word h) DCBA; (Low word L) UZYX

A	Bit 16 - Bit 31 Delta servo alarm	X	Bit 0 - Bit 15 Error code
B		Y	
C		Z	
D		U	

Definitions are as follows:

- UZYX: error code. Refer to the error code definition in DS402.
- DCBA: Delta servo alarm. Refer to Chapter 14 Troubleshooting.

Example:

When you operate the servo, if the encoder cable is not correctly connected, the servo drive panel displays AL011 and its error code is stored in the 1003h array. The display is as follows:

Byte:	High word	Low word
	Delta servo alarm (UINT16)	Error code (UINT16)
	0x0011	0x7305

AL011 is defined as “CN2 communication failed” based on the Delta servo alarm.

Error code: 0x7305 is defined as “Incremental sensor 1 fault” according to DS402.

Object 1006h: Communication cycle period

Index	1006h
Name	Communication cycle period
Object code	VAR
Data type	UNSIGNED32
Access	RW
PDO mapping	No
Setting range	UNSIGNED32
Default	0
Unit	μs

Object function:

This object is to set the communication cycle (unit: μs). The communication cycle is the interval between two SYNCs. If you are not using SYNC, set this object to 0.

Objects 1600h - 1603h: Receive PDO mapping parameter

Index	1600h, 1601h, 1602h, 1603h
Name	Receive PDO mapping parameter
Object code	RECORD
Data type	PDO mapping
Access	RW
Note	The total length of objects in a group of PDO cannot exceed 64 bits.

Sub-index	0
Description	Number of PDO mappings
Data type	UNSIGNED8
Access	RW
PDO mapping	No
Setting range	0: disable 1 - 8: set the number of PDO mapping and enable the function
Default	0

Sub-index	1 - 8
Description	Specify the 1 <sup>st</sup> (to 8 <sup>th</sup> ) object and its content to be mapped
Data type	UNSIGNED32
Access	RW
PDO mapping	No
Setting range	UNSIGNED32
Default	0

The format of this object is as follows:

Bit	31	30	29	28	27	26	25	24	23	22	21	20	19	18	17	16
Bit	15	14	13	12	11	10	9	8	7	6	5	4	3	2	1	0

Bit	Function
Bit 0 - Bit 7	Object data length
Bit 8 - Bit 15	Object sub-index
Bit 16 - Bit 31	Object index

# 13

Example:

To set the three PDOs, OD 6040h, OD 607Ah, and OD 6060h, in the first group of PDO, the setting is as follows.

Mapping parameter setting for RxPDO	Data			Description
OD 1600h sub0	3			Set 3 PDO mappings.
OD 1600h sub1	6040h	00h	10h	Mapping Controlword (6040h); data length is 16-bit
OD 1600h sub2	607Ah	00h	20h	Mapping target position (607Ah); data length is 32-bit
OD 1600h sub3	6060h	00h	08h	Mapping mode (6060h); data length is 8-bit
Note	The total length is 38h (56-bit) which meets the specification of less than 64-bit.			

### Objects 1A00h - 1A03h: Transmit PDO mapping parameter

Index	1A00h, 1A01h, 1A02h, 1A03h
Name	Transmit PDO mapping parameter
Object code	RECORD
Data type	PDO mapping
Access	RW
Note	The total length of objects in a group of PDO cannot exceed 64 bits.

Sub-index	0
Description	Number of PDO mappings
Data type	UNSIGNED8
Access	RW
PDO mapping	No
Setting range	0: disable 1 - 8: set the number of PDO mapping and enable the function
Default	0

Sub-index	1 - 8
Description	Specify the 1 <sup>st</sup> (to 8 <sup>th</sup> ) object and its content to be mapped
Data type	UNSIGNED32
Access	RW
PDO mapping	No
Setting range	UNSIGNED32
Default	0

Format of this object: (High word h) DCBA; (Low word L) UZYX

DCBA	Bit 16 - Bit 31 Object index	YX	Bit 0 - Bit 7 Object data length
		UZ	Bit 8 - Bit 15 Object sub-index

## Object 1C12h: RxPDO assign

Index	1C12h
Name	RxPDO assign
Object code	ARRAY
Data type	UNSIGNED16
Access	RW
PDO mapping	No

Sub-index	0
Description	Number of sub-index
Data type	UNSIGNED8
Access	RW
PDO mapping	No
Setting range	0 - 1
Default	1

Sub-index	0
Description	Specify the RxPDO index to be used
Data type	UNSIGNED16
Access	RW
PDO mapping	No
Setting range	0x1600, 0x1601, 0x1602, 0x1603
Default	0x1601

## Object 1C13h: TxPDO assign

Index	1C13h
Name	TxPDO assign
Object code	ARRAY
Data type	UNSIGNED16
Access	RW
PDO mapping	No

Sub-index	0
Description	Number of sub-index
Data type	UNSIGNED8
Access	RW
PDO mapping	No
Setting range	0 - 1
Default	1

Sub-index	0
Description	Specify the TxPDO index to be used
Data type	UNSIGNED16
Access	RW
PDO mapping	No
Setting range	0x1A00, 0x1A01, 0x1A02, 0x1A03
Default	0x1A01

### 13.4.3.2 OD 2XXXh servo parameter group

Object 2XXXh: Parameter Mapping

Index	2XXXh
Name	Parameter Mapping
Object code	VAR
Data type	INTEGER16 / INTEGER32
Access	RW
PDO mapping	Yes
Setting range	INTEGER16 / INTEGER32
Default	N/A

Object function:

Access the servo parameters with the OD 2XXXh group. The parameter number and index are converted as follows:

<b>Pa.bcd &lt;= = &gt; 2aBCh</b>
<b>'BC' is hexadecimal format of 'bcd'</b>

Read the index first to get the information of the parameter length, and then use SDO or PDO to change the data.

Example 1:

Object 2300h: Node-ID [P3.000]

Index	2300h
Name	Node-ID
Object code	VAR
Data type	INTEGER16
Access	RW
PDO mapping	Yes
Setting range	INTEGER16
Default	7F

Example 2:

Object 212Ch: Electronic Gear [P1.044]

Index	212Ch
Name	Electronic Gear
Object code	VAR
Data type	INTEGER32
Access	RW
PDO mapping	Yes
Setting range	INTEGER32
Default	1

### 13.4.3.3 OD 6XXXh communication object group

Object 603Fh: Error code (CANopen defined)

Index	603Fh
Name	Error code
Object code	VAR
Data type	UNSIGNED16
Access	RO
PDO mapping	Yes
Setting range	UNSIGNED16
Default	0

Object 6040h: Controlword

Index	6040h
Name	Controlword
Object code	VAR
Data type	UNSIGNED16
Access	RW
PDO mapping	Yes
Setting range	UNSIGNED16
Default	0x0004

Object function:

The Controlword contains many functions, such as Servo On, command triggering, fault reset, and quick stop. The state machine architecture is as follows:

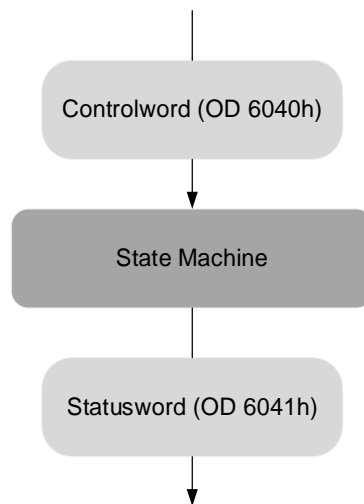

Bit	15	14	13	12	11	10	9	8	7	6	5	4	3	2	1	0
-----	----	----	----	----	----	----	---	---	---	---	---	---	---	---	---	---

Bit	Function	Description
Bit 0	Switch on	Ready for Servo On.
Bit 1	Enable voltage	-
Bit 2	Quick stop (B contact (NC))	-
Bit 3	Enable operation	Servo On.



# 13

Bit	Function	Description
Bit 4 - Bit 6	Defined in each operation mode	These bits are individually defined according to the operation mode, as shown in the following table.
Bit 7	Fault reset	-
Bit 8	Halt	-
Bit 9 - Bit 15	Reserved	-

Bits 4 - 6 are individually defined according to the operation mode, as shown in the following table:

Bit	Definition in each operation mode		
	Profile Position mode	Homing mode	Profile Velocity mode Profile Torque mode Interpolated Position mode Cyclic Synchronous Position mode Cyclic Synchronous Velocity mode Cyclic Synchronous Torque mode
Bit 4	Command triggering (rising-edge triggered)	Homing (rising-edge triggered)	-
Bit 5	Function for the command to take immediate effect	-	-
Bit 6	0: absolute position command 1: relative position command	-	-

Note: - indicates the bit is invalid.

Finite state machine (as shown in the following diagram) defines the behavior of a servo drive system. Each state represents an internal or external behavior. For example, the servo drive can execute point-to-point motion only in the Operation enabled state.

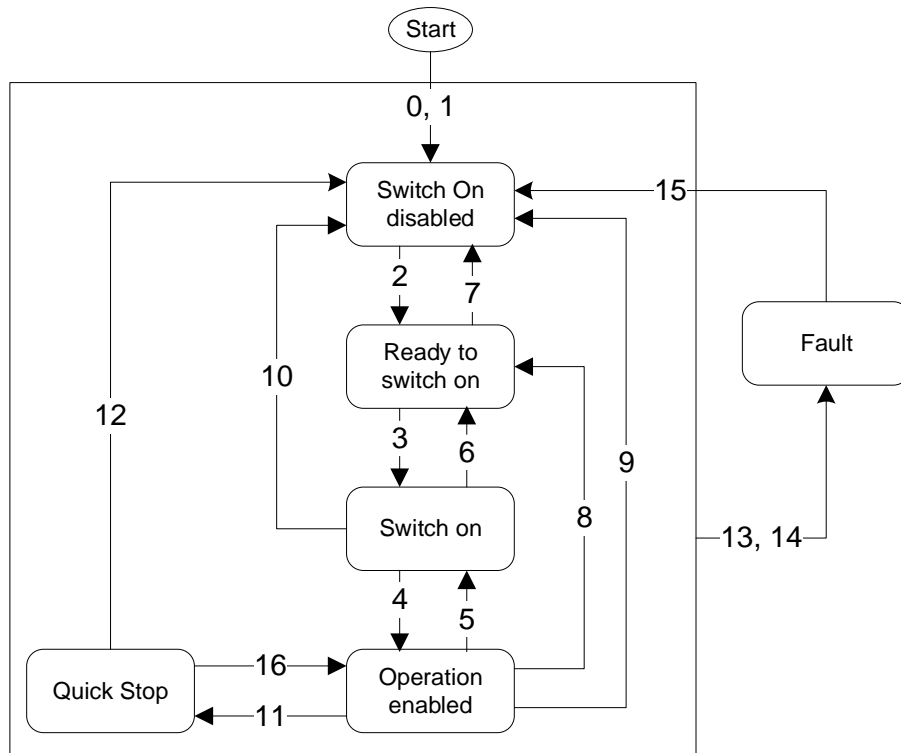

The state transition is defined as follows:

Transition	Event	Action
0, 1	Automatic transition after power-on	Device boot and initialization
2	Shutdown command	N/A
3	Switch on command	Servo is ready for Servo On
4	Enable operation command	Servo switches to Servo On and enters the mode in which the controller is allowed to issue a motion command
5	Disable operation command	Servo switches to Servo Off
6	Shutdown command	N/A
7	Disable voltage or quick stop command	N/A
8	Shutdown command	Servo switches to Servo Off
9	Disable voltage command	Servo switches to Servo Off
10	Disable voltage or quick stop command	N/A
11	Quick stop command The following two errors belong to this quick stop type: 1. Positive / negative limit switch triggered 2. Quick stop triggered by the Controlword (OD 6040h [Bit 2] = 0)	Quick stop function is enabled. The time setting for deceleration to a stop is different for the two errors. 1. OD 2503h (P5.003) 2. OD 6085h
12	Disable voltage command (OD 6040h = 0000 0110 or OD 6040h [Bit 1] = 0)	Servo switches to Servo Off
13, 14	Alarm occurs	Servo switches to Servo Off
15	Fault reset	N/A
16	Enable operation command; no alarm	Motion operation restart. The restart action is mode-dependent.

State transition can be achieved with the Controlword (OD 6040h).

The commands are as follows:

Command	Bit of OD 6040h					Transition
	Bit 7	Bit 3	Bit 2	Bit 1	Bit 0	
Shutdown	0	X	1	1	0	2, 6, 8
Switch on	0	0	1	1	1	3
Switch on + Enable operation	0	1	1	1	1	3 + 4
Disable voltage	0	X	X	0	X	7, 9, 10, 12
Quick stop	0	X	0	1	X	7, 10, 11
Disable operation	0	0	1	1	1	5
Enable operation	0	1	1	1	1	4, 16
Fault reset		X	X	X	X	15

Object 6041h: Statusword

Index	6041h
Name	Statusword
Object code	VAR
Data type	UNSIGNED16
Access	RO
PDO mapping	Yes
Setting range	UNSIGNED16
Default	0

Object function:

The Statusword contains many statuses, such as Servo On, command statuses, fault signal, and quick stop. The state machine architecture is as follows:

Bit	15	14	13	12	11	10	9	8	7	6	5	4	3	2	1	0
-----	----	----	----	----	----	----	---	---	---	---	---	---	---	---	---	---

Bit	Status		Description
Bit 0	Ready to switch on	Ready to be activated	Bit 0 - Bit 6: current status of the servo drive (see the following table for details).
Bit 1	Switched on	Servo ready	
Bit 2	Operation enabled	Servo On	
Bit 3	Fault	Fault signal	
Bit 4	Voltage enabled	Servo is powered on	
Bit 5	Quick stop	Quick stop	
Bit 6	Switch on disabled	Servo disabled	
Bit 7	Warning	Warning signal	When outputting the warning signal, the servo keeps outputting the Servo On signal.
Bit 8	Reserved	-	-
Bit 9	Remote	Remote control	-
Bit 10	Target reached	Target reached	-
Bit 11	Reserved	-	-
Bit 12 - Bit 13	-	-	These bits are individually defined according to the operation mode, as shown in the following table.
Bit 14	Positive limit	Positive limit	-
Bit 15	Negative limit	Negative limit	-

Bit 0 - Bit 6: current status of the servo drive.

Bit 6	Bit 5	Bit 4	Bit 3	Bit 2	Bit 1	Bit 0	Description
0	-	-	0	0	0	0	Not ready to switch on.
1	-	-	0	0	0	0	Switch on disabled.
0	1	-	0	0	0	1	Ready to switch on.
0	1	-	0	0	1	1	Switched on.
0	1	-	0	1	1	1	Operation enabled (Servo On).
0	0	-	0	1	1	1	Quick stop active.
0	-	-	1	1	1	1	Fault reaction active.
0	-	-	1	0	0	0	Servo fault (servo switches to Servo Off).

Note: 0 indicates the bit is off, 1 indicates the bit is on, and - indicates the bit is invalid.

Bit 12 - Bit 13: current status of the servo drive.

Bit	Definition in each operation mode						
	PP	PV	PT	Homing	CSP	CSV	CST
Bit 12	Set-point acknowledge (servo received the command signal)	Zero speed	-	Homing is complete	Mode is in effect	Mode is in effect	Mode is in effect
Bit 13	Following error	-	-	Homing error	Following error	-	-

Note: - indicates the bit is invalid.

Object 605Bh: Shutdown option code

Index	605Bh
Name	Shutdown option code
Object code	VAR
Data type	INTEGER16
Access	RW
PDO mapping	Yes
Setting range	INTEGER16
Default	0

Object function:

Set to 0: when Servo Off, the dynamic brake has no effect, so the motor runs freely and the machine stops only by friction.

Set to -1: when Servo Off, the servo stops with the operation of the dynamic brake.

Note: when P3.012.Z is set to 1, the non-volatile setting for this object is enabled.

Object 6060h: Modes of operation

Index	6060h
Name	Modes of operation
Object code	VAR
Data type	INTEGER8
Access	RW
PDO mapping	Yes
Setting range	INTEGER8
Default	0

13

# 13

Object function:

This object sets the mode for operation.

Setting value	Mode
0	Reserved
1	Profile Position mode
2	Reserved
3	Profile Velocity mode
4	Profile Torque mode
5	Reserved
6	Homing mode
7	Reserved
8	Cyclic Synchronous Position mode
9	Cyclic Synchronous Velocity mode
10	Cyclic Synchronous Torque mode

Object 6061h: Modes of operation display

Index	6061h
Name	Modes of operation display
Object code	VAR
Data type	INTEGER8
Access	RO
PDO mapping	Yes
Setting range	INTEGER8
Default	0

Object function:

This object displays the current operation mode. Refer to the table in OD 6060h.

Object 6062h: Position demand value (PUU)

Index	6062h
Name	Position demand value
Object code	VAR
Data type	INTEGER32
Access	RO
PDO mapping	Yes
Setting range	INTEGER32
Default	0
Unit	PUU

Object function:

This position demand value is the interpolation command calculated by the servo internal interpolator. This command passes through the servo internal filter. For its detailed location, refer to the servo architecture diagram of each mode.

Object 6063h: Position actual internal value (Pulse)

Index	6063h
Name	Position actual internal value
Object code	VAR
Data type	INTEGER32
Access	RO
PDO mapping	Yes
Setting range	INTEGER32
Default	0
Unit	Pulse (unit for encoder pulse resolution) The ASDA-A2 servo drive generates 1,280,000 pulses per motor revolution. The ASDA-A3 / ASDA-B3 servo drive generates 16,777,216 pulses per motor revolution.

Object 6064h: Position actual value (PUU)

Index	6064h
Name	Position actual value
Object code	VAR
Data type	INTEGER32
Access	RO
PDO mapping	Yes
Setting range	INTEGER32
Default	0
Unit	PUU

Object 6065h: Following error window

Index	6065h
Name	Following error window
Object code	VAR
Data type	UNSIGNED32
Access	RW
PDO mapping	Yes
Setting range	UNSIGNED32
Default	50331648
Unit	PUU

Object function:

When the following error actual value (OD 60F4h) exceeds this setting range, AL009 (Excessive deviation of Position command) is triggered.

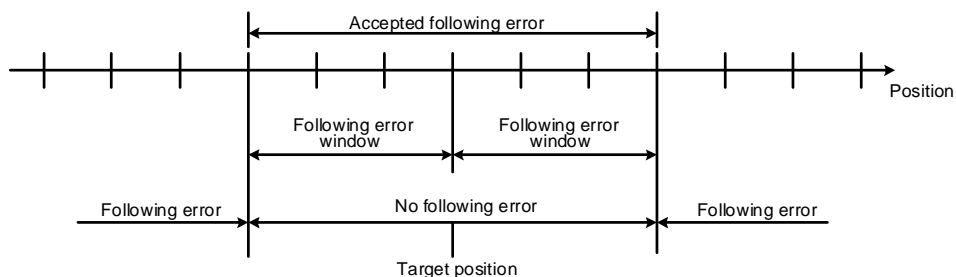

Note: when P3.012.Z is set to 1, the non-volatile setting for this object is enabled.

# 13

## Object 6067h: Position window

Index	6067h
Name	Position window
Object code	VAR
Data type	UNSIGNED32
Access	RW
PDO mapping	Yes
Setting range	UNSIGNED32
Default	100
Unit	PUU

### Object function:

When the difference (absolute value) between the target position (PP mode: OD 607Ah) and the position actual value (OD 6064h) is within the range set in OD 6067h (Position window), and the duration of this condition is longer than the time set in OD 6068h (Position window time), OD 6041h [Bit 10] (Target reached) is output.

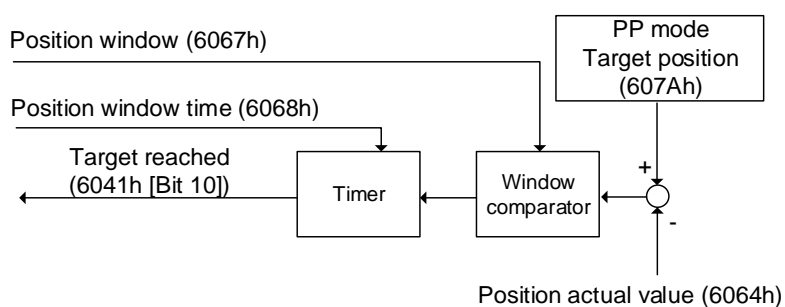
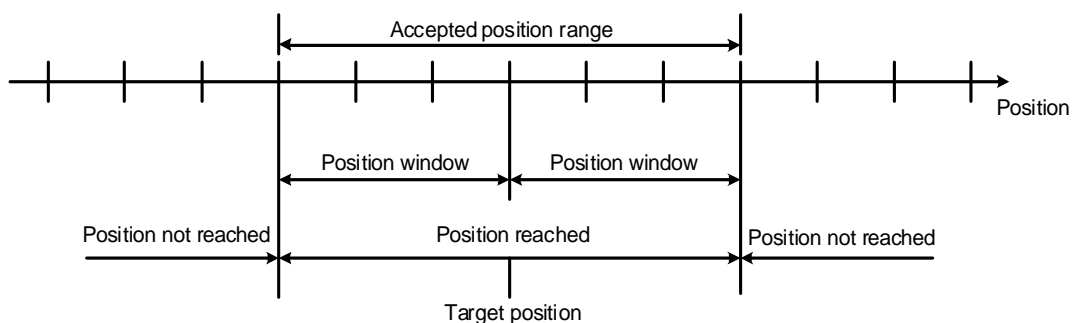

Object 6068h: Position window time

Index	6068h
Name	Position window time
Object code	VAR
Data type	UNSIGNED16
Access	RW
PDO mapping	Yes
Setting range	UNSIGNED16
Default	0
Unit	ms

Object function:

When the difference (absolute value) between the target position (PP mode: OD 607Ah) and the position actual value (OD 6064h) is within the range set in OD 6067h (Position window), and the duration of this condition is longer than the time set in OD 6068h (Position window time), OD 6041h [Bit 10] (Target reached) is output.

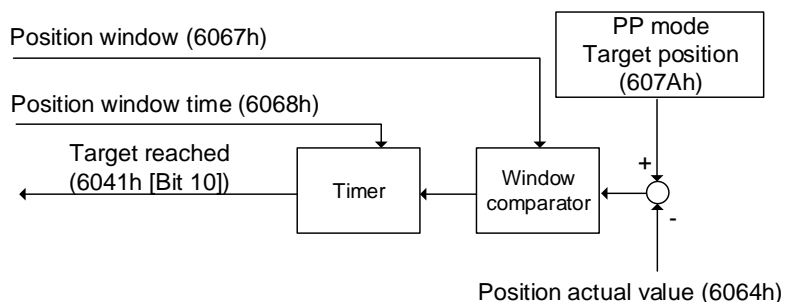

Object 606Bh: Velocity demand value

Index	606Bh
Name	Velocity demand value
Object code	VAR
Data type	INTEGER32
Access	RO
PDO mapping	Yes
Setting range	INTEGER32
Unit	0.1 rpm

Object function:

The velocity demand value is a command generated by the speed trajectory generator and filtered by the command filter of the drive. This object only works in Profile Velocity mode and Cyclic Synchronous Velocity mode.



# 13

## Object 606Ch: Velocity actual value

Index	606Ch
Name	Velocity actual value
Object code	VAR
Data type	INTEGER32
Access	RO
PDO mapping	Yes
Setting range	INTEGER32
Unit	0.1 rpm

Object function:

Returns the motor speed at present for monitoring.

## Object 606Dh: Velocity window

Index	606Dh
Name	Velocity window
Object code	VAR
Data type	UNSIGNED16
Access	RW
PDO mapping	Yes
Setting range	0 - 3000
Default	100
Unit	0.1 rpm

Object function:

The window comparator compares the speed difference with the velocity window (OD 606Dh). When the difference (absolute value) is within the range of the velocity window and the duration of this condition is longer than the time set in the velocity window time (OD 606Eh), OD 6041h [Bit 10] (Target reached) is output. This object only works in Profile Velocity mode.

Note: when P3.012.Z is set to 1, the non-volatile setting for this object is enabled.

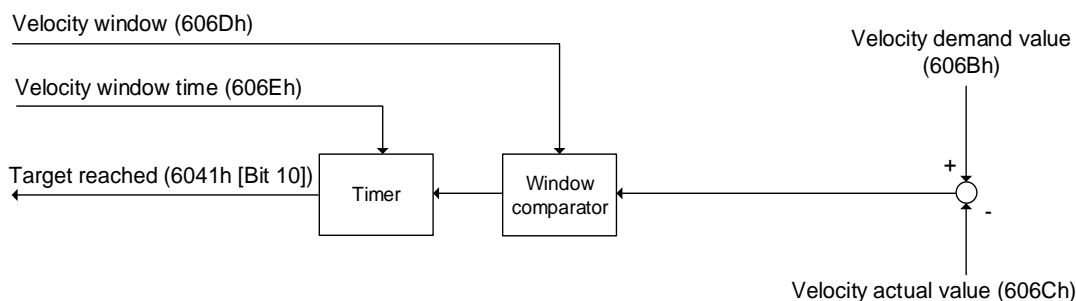

## Object 606Eh: Velocity window time

Index	606Eh
Name	Velocity window time
Object code	VAR
Data type	UNSIGNED16
Access	RW
PDO mapping	Yes
Setting range	UNSIGNED16
Default	0
Unit	ms

## Object function:

Refer to OD 606Dh for the description of the object.

Note: when P3.012.Z is set to 1, the non-volatile setting for this object is enabled.

## Object 606Fh: Velocity threshold

Index	606Fh
Name	Velocity threshold
Object code	VAR
Data type	UNSIGNED16
Access	RW
PDO mapping	Yes
Setting range	0 - 2000
Default	100
Unit	0.1 rpm

## Object function:

This object sets the range for the zero-speed signal output. When the forward or reverse speed (absolute value) of the motor is lower than this set value, the zero-speed signal (OD 6041h [Bit 12]) outputs 1.

Note: when P3.012.Z is set to 1, the non-volatile setting for this object is enabled.

## 13

## Object 6071h: Target torque

Index	6071h
Name	Target torque
Object code	VAR
Data type	INTEGER16
Access	RW
PDO mapping	Yes
Setting range	-3500 to +3500
Default	0
Unit	0.1%

## Object function:

This object sets the target torque (unit: 0.1%) in Profile Torque mode and Cyclic Synchronous Torque mode. If OD 6071h = 1000 (100.0%), it corresponds to the motor rated torque.

## Object 6072h: Max torque

Index	6072h
Name	Max torque
Object code	VAR
Data type	UNSIGNED16
Access	RW
PDO mapping	Yes
Setting range	0 - 3500
Default	3500
Unit	0.1%

## Object function:

This object sets the maximum torque (unit: 0.1%) in Profile Torque mode and Cyclic Synchronous Torque mode.

## Object 6074h: Torque demand value

Index	6074h
Name	Torque demand value
Object code	VAR
Data type	INTEGER16
Access	RO
PDO mapping	Yes
Setting range	INTEGER16
Default	0
Unit	0.1%

## Object function:

The torque demand value is the command generated by the speed trajectory generator and filtered by the command filter of the drive. This object only works in Profile Torque mode and Cyclic Synchronous Torque mode.

## Object 6075h: Motor rated current

Index	6075h
Name	Motor rated current
Object code	VAR
Data type	UNSIGNED32
Access	RO
PDO mapping	Yes
Setting range	UNSIGNED32
Default	0
Unit	mA

## Object function:

This object displays the rated current specified on the motor nameplate.

## Object 6076h: Motor rated torque

Index	6076h
Name	Motor rated torque
Object code	VAR
Data type	UNSIGNED32
Access	RO
PDO mapping	Yes
Setting range	UNSIGNED32
Default	0
Unit	0.001 N-m

## Object function:

This object displays the rated torque specified on the motor nameplate.

## Object 6077h: Torque actual value

Index	6077h
Name	Torque actual value
Object code	VAR
Data type	INTEGER16
Access	RO
PDO mapping	Yes
Setting range	INTEGER16
Default	0
Unit	0.1%

## Object function:

This object is the motor torque feedback in percentage at present.

## 13

## Object 6078h: Current actual value

Index	6078h
Name	Current actual value
Object code	VAR
Data type	INTEGER16
Access	RO
PDO mapping	Yes
Setting range	INTEGER16
Default	0
Unit	0.1%

## Object function:

This object is the motor current feedback in percentage at present.

## Object 607Ah: Target position

Index	607Ah
Name	Target position
Object code	VAR
Data type	INTEGER32
Access	RW
PDO mapping	Yes
Setting range	INTEGER32
Default	0
Unit	PUU

## Object function:

This object only works in Profile Position mode and Cyclic Synchronous Position mode.

For more details, refer to Sections 13.3.1 and 13.3.5.

## Object 607Ch: Home offset

Index	607Ch
Name	Home offset
Object code	VAR
Data type	INTEGER32
Access	RW
PDO mapping	Yes
Setting range	INTEGER32
Default	0
Unit	PUU

## Object function:

The origin reference point which the system looks for during the homing procedure is Home position, such as the origin sensor and Z pulse. When the origin reference point is found, the position offset from this point is the user-defined origin (Zero position), and the offset value is Home offset.

Note: when P3.012.Z is set to 1, the non-volatile setting for this object is enabled.

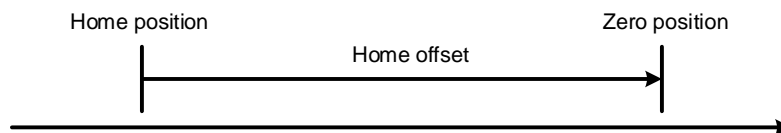

## Object 607Dh: Software position limit

Index	607Dh
Name	Software position limit
Object code	ARRAY
Data type	INTEGER32
Access	RW

Sub-index	0
Description	Number of entries
Data type	UNSIGNED8
Access	RO
PDO mapping	Yes
Setting range	2
Default	2

Sub-index	1
Description	Min position limit
Data type	INTEGER32
Access	RW
PDO mapping	Yes
Setting range	-2147483648 to +2147483647
Default	-2147483648
Unit	PUU

## 13

Sub-index	2
Description	Max position limit
Data type	INTEGER32
Access	RW
PDO mapping	Yes
Setting range	-2147483648 to +2147483647
Default	+2147483647
Unit	PUU

Note: when P3.012.Z is set to 1, the non-volatile setting for this object is enabled.

## Object 607Fh: Max profile velocity

Index	607Fh
Name	Max profile velocity
Object code	VAR
Data type	UNSIGNED32
Access	RW
PDO mapping	Yes
Setting range	UNSIGNED32
Default	Varies depending on the motor model
Corresponding servo parameter	P1.055 (rpm) * 10
Unit	0.1 rpm

Object function:

The unit of this object is 0.1 rpm, so dividing this object by 10 is equivalent to P1.055 (Maximum speed limit in units of 1 rpm).

Note: when P3.012.Z is set to 1, the non-volatile setting for this object is enabled.

## Object 6080h: Max motor speed

Index	6080h
Name	Max motor speed
Object code	VAR
Data type	UNSIGNED32
Access	RW
PDO mapping	Yes
Setting range	UNSIGNED32
Default	Varies depending on the motor model
Corresponding servo parameter	P1.055
Unit	rpm

Object function:

This object is equivalent to P1.055, which is the maximum speed limit of the motor.

Note: when P3.012.Z is set to 1, the non-volatile setting for this object is enabled.

## Object 6081h: Profile velocity

Index	6081h
Name	Profile velocity
Object code	VAR
Data type	UNSIGNED32
Access	RW
PDO mapping	Yes
Setting range	UNSIGNED32
Default	10000
Unit	PUU/s

## Object function:

This object only works in Profile Position mode. For more details, refer to Section 13.3.1.

## Object 6083h: Profile acceleration

Index	6083h
Name	Profile acceleration
Object code	VAR
Data type	UNSIGNED32
Access	RW
PDO mapping	Yes
Setting range	1 - 65500
Default	200
Unit	ms

## Object function:

The time slope set by this object is the time required for the motor to accelerate from 0 rpm to 3,000 rpm. This object only works in Profile Position mode and Profile Velocity mode.

## Object 6084h: Profile deceleration

Index	6084h
Name	Profile deceleration
Object code	VAR
Data type	UNSIGNED32
Access	RW
PDO mapping	Yes
Setting range	1 - 65500
Default	200
Unit	ms

## Object function:

The time slope set by this object is the time required for the motor to decelerate from 3,000 rpm to 0 rpm. This object only works in Profile Position mode and Profile Velocity mode.



# 13

Object 6085h: Quick stop deceleration

Index	6085h
Name	Quick stop deceleration
Object code	VAR
Data type	UNSIGNED32
Access	RW
PDO mapping	Yes
Setting range	1 - 65500
Default	200
Unit	ms

Object function:

The time slope set by this object is the time required for the motor to decelerate from 3,000 rpm to 0 rpm.

Object 6086h: Motion profile type

Index	6086h
Name	Motion profile type
Object code	VAR
Data type	INTEGER16
Access	RO
PDO mapping	Yes
Setting range	0
Default	0

Object function:

This object sets the type of motion profile for operation. Currently, only linear ramp (trapezoidal profile) is available.

Setting value	Mode
0	Linear ramp (trapezoidal profile)

## Object 6087h: Torque slope

Index	6087h
Name	Torque slope
Object code	VAR
Data type	UNSIGNED32
Access	RW
PDO mapping	Yes
Setting range	0 - 65500
Default	200
Unit	ms

## Object function:

The time slope set by this object is the time required for the motor to change from 0% to 100% of the rated torque.

Note: when P3.012.Z is set to 1, the non-volatile setting for this object is enabled.

## Object 6093h: Position factor

Index	6093h
Name	Position factor
Object code	ARRAY
Data type	UNSIGNED32
Access	RW
PDO mapping	Yes
Corresponding servo parameter	P1.044 and P1.045
Note	Position factor = Numerator / Feed_constant

Sub-index	0
Description	Number of sub-index
Data type	UNSIGNED8
Access	RO
PDO mapping	No
Setting range	2
Default	2

Sub-index	1
Description	E-Gear ratio numerator
Data type	UNSIGNED32
Access	RW
PDO mapping	Yes
Default	1
Corresponding servo parameter	P1.044
Note	For the E-Gear ratio setting, refer to Section 6.2.5.

# 13

Sub-index	2
Description	E-Gear ratio denominator
Data type	UNSIGNED32
Access	RW
PDO mapping	Yes
Default	1
Corresponding servo parameter	P1.045
Note	For the E-Gear ratio setting, refer to Section 6.2.5.

Note: when P3.012.Z is set to 1, the non-volatile setting for this object is enabled.

### Object 6098h: Homing method

Index	6098h
Name	Homing method
Object code	VAR
Data type	INTEGER8
Access	RW
PDO mapping	Yes
Setting range	-4 to 35
Default	0

#### Object function:

The homing methods include looking for the Z pulse (Methods 1 - 14, 33, 34, 36, 37), not looking for the Z pulse (Methods 17 - 30), defining the current position as the origin (Method 35), and looking for the hard stop (Methods 36 - 39). Methods 15, 16, 31, and 32 are reserved. To use Methods 1 to 35, set OD 6098h to 1 to 35. To use Methods 36 to 39, set OD 6098h to -1 to -4.

#### Method 1: homing on the negative limit switch and Z pulse

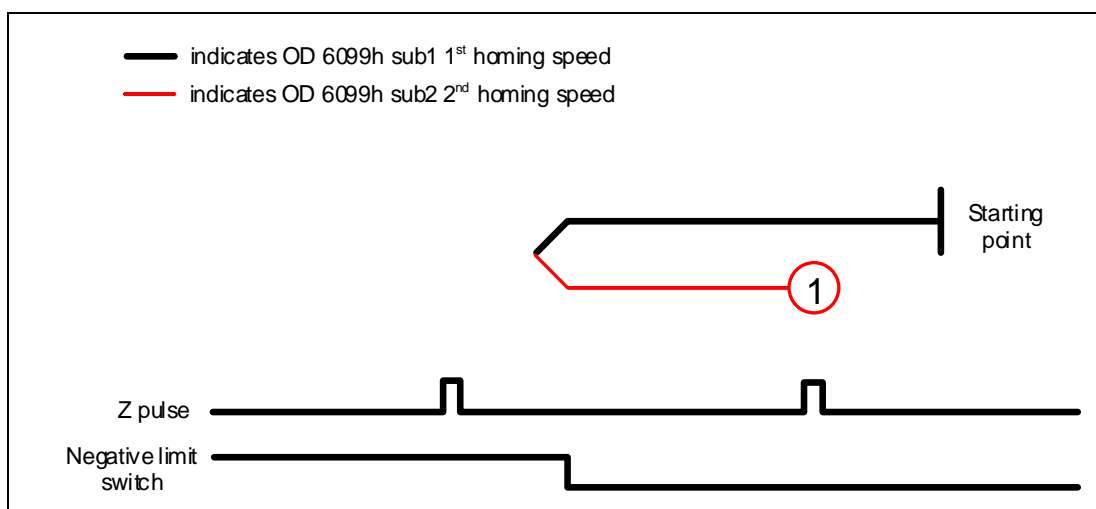

Method 2: homing on the positive limit switch and Z pulse

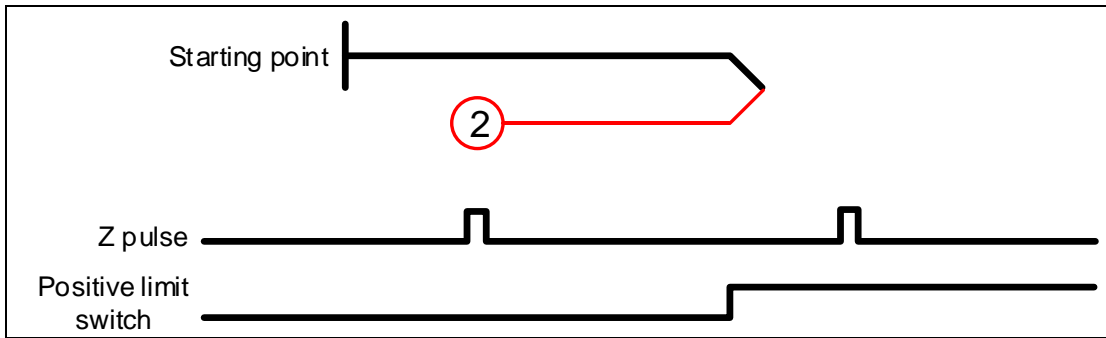

13

Methods 3 and 4: homing on the home switch and Z pulse

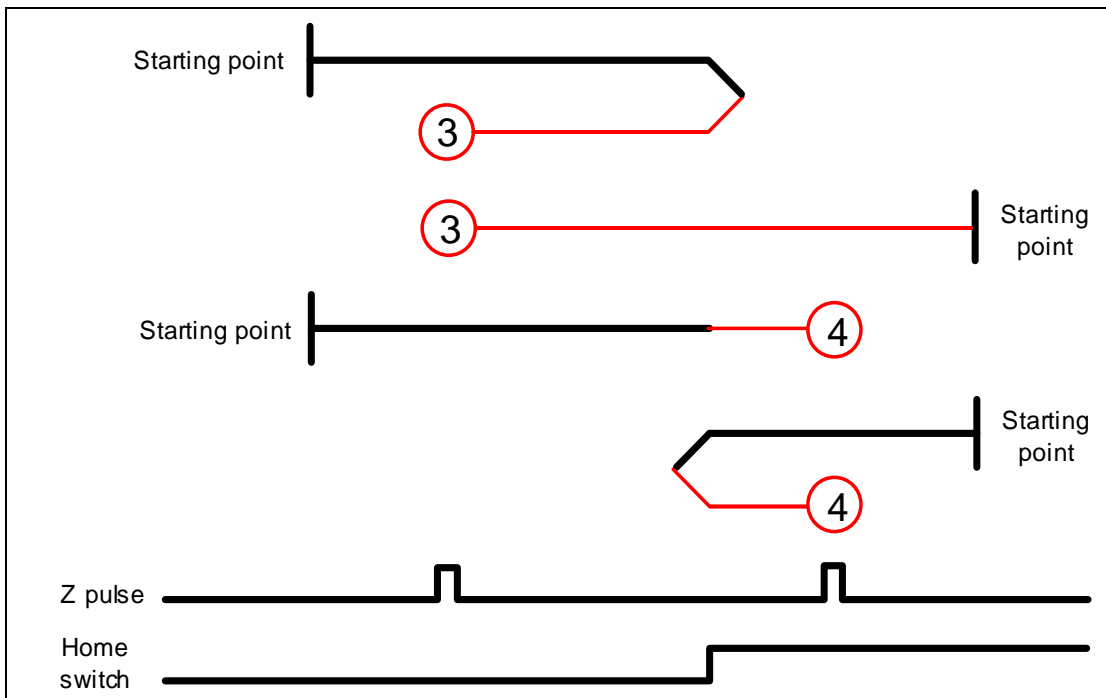

# 13

Methods 5 and 6: homing on the home switch and Z pulse

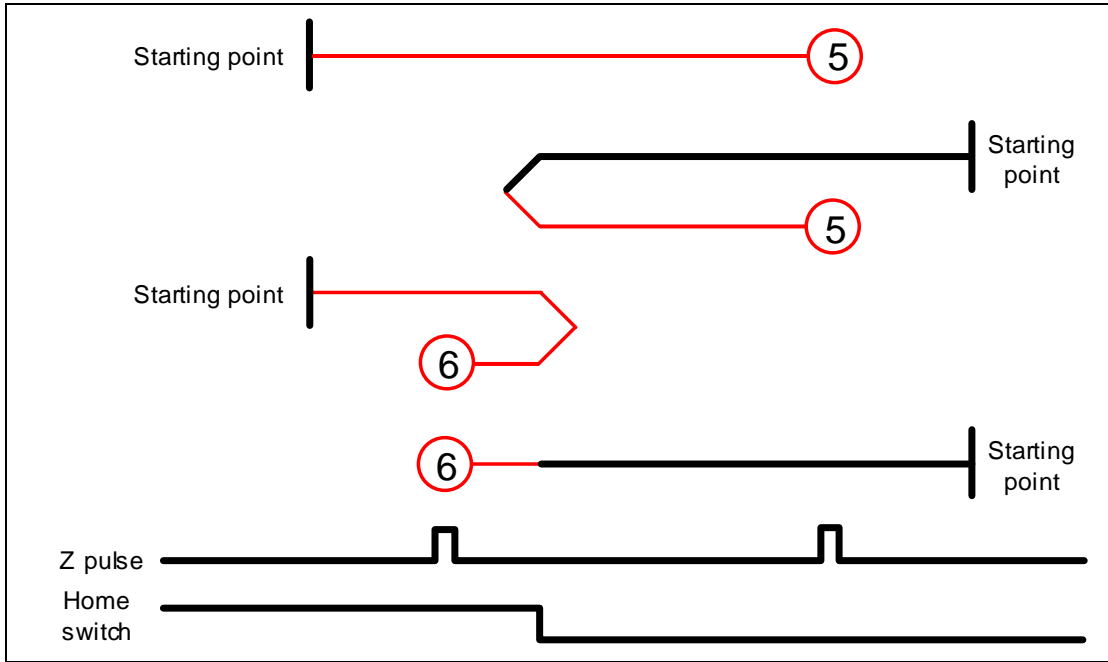

Method 7: homing on the positive limit switch, home switch, and Z pulse

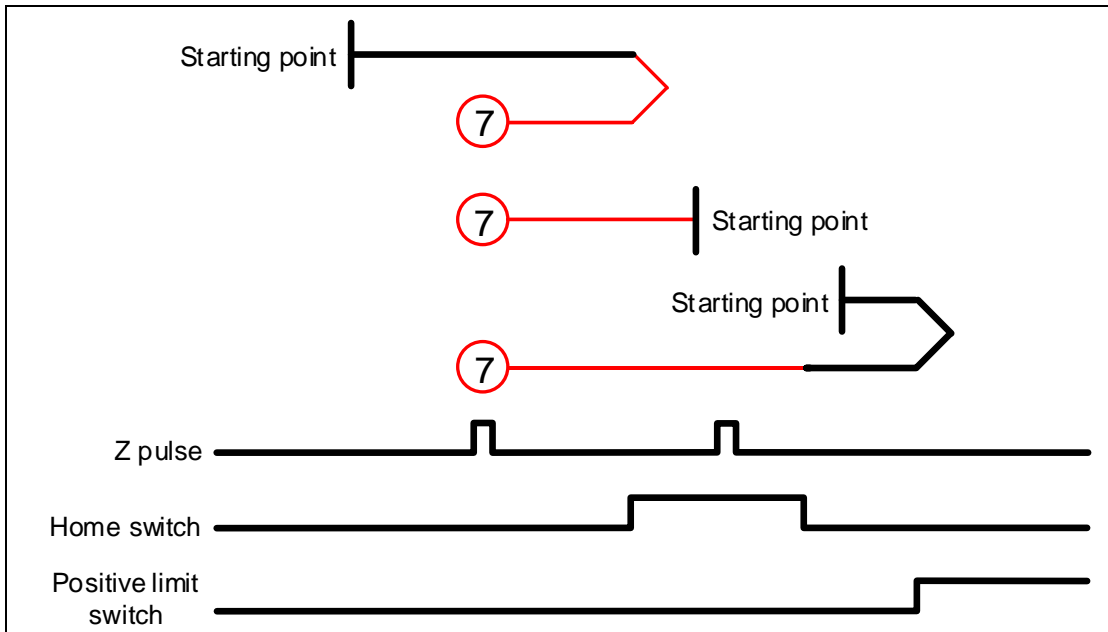

Method 8: homing on the positive limit switch, home switch, and Z pulse

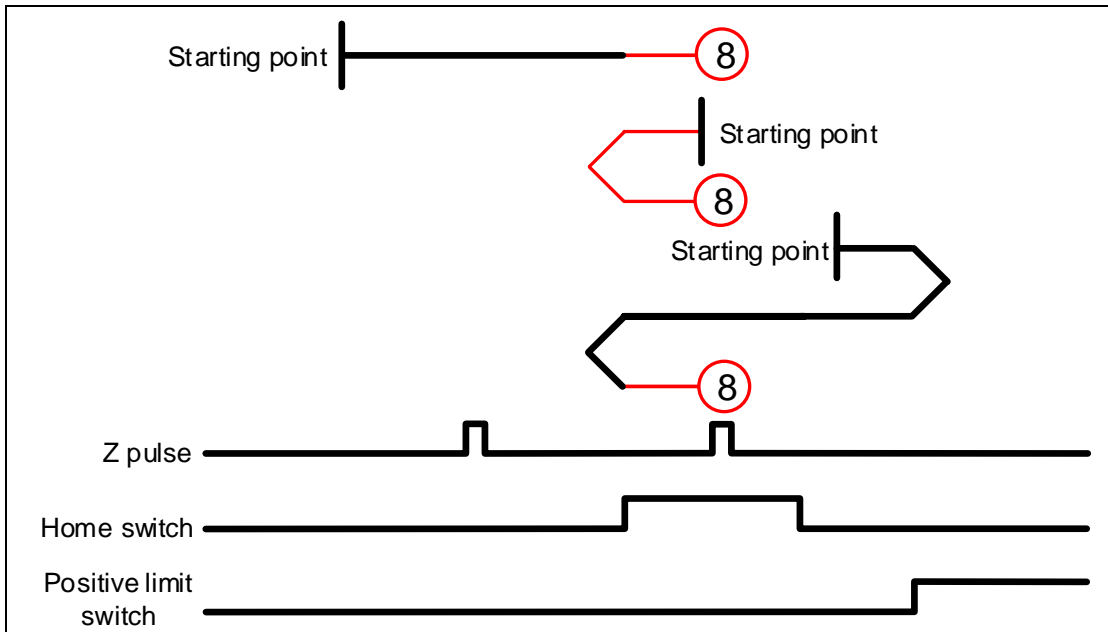

Method 9: homing on the positive limit switch, home switch, and Z pulse

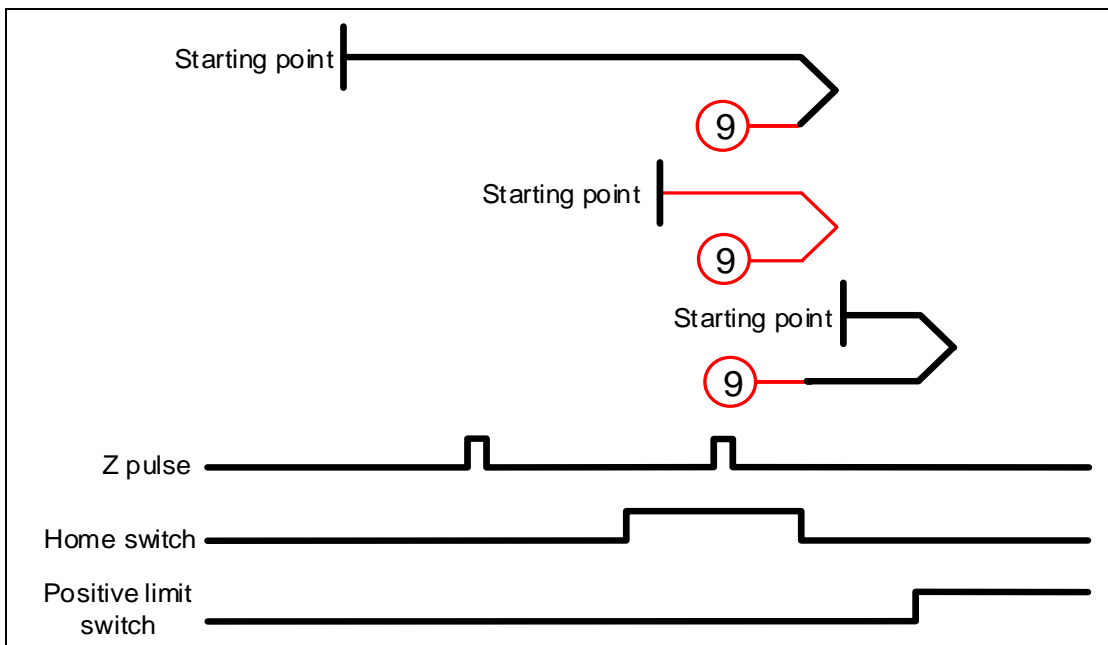

# 13

Method 10: homing on the positive limit switch, home switch, and Z pulse

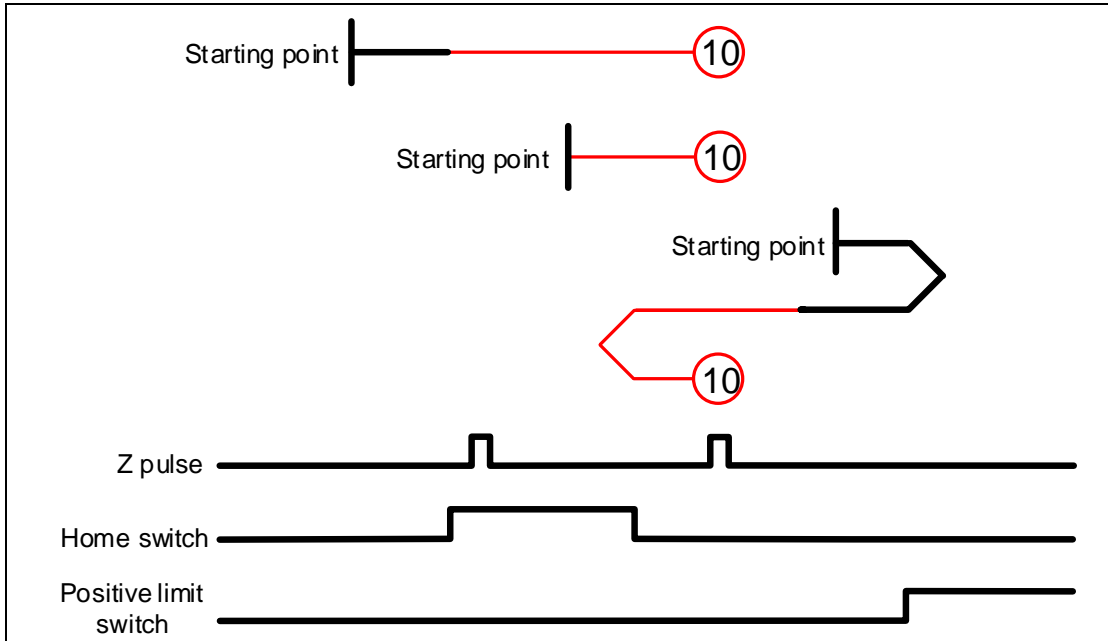

Method 11: homing on the negative limit switch, home switch, and Z pulse

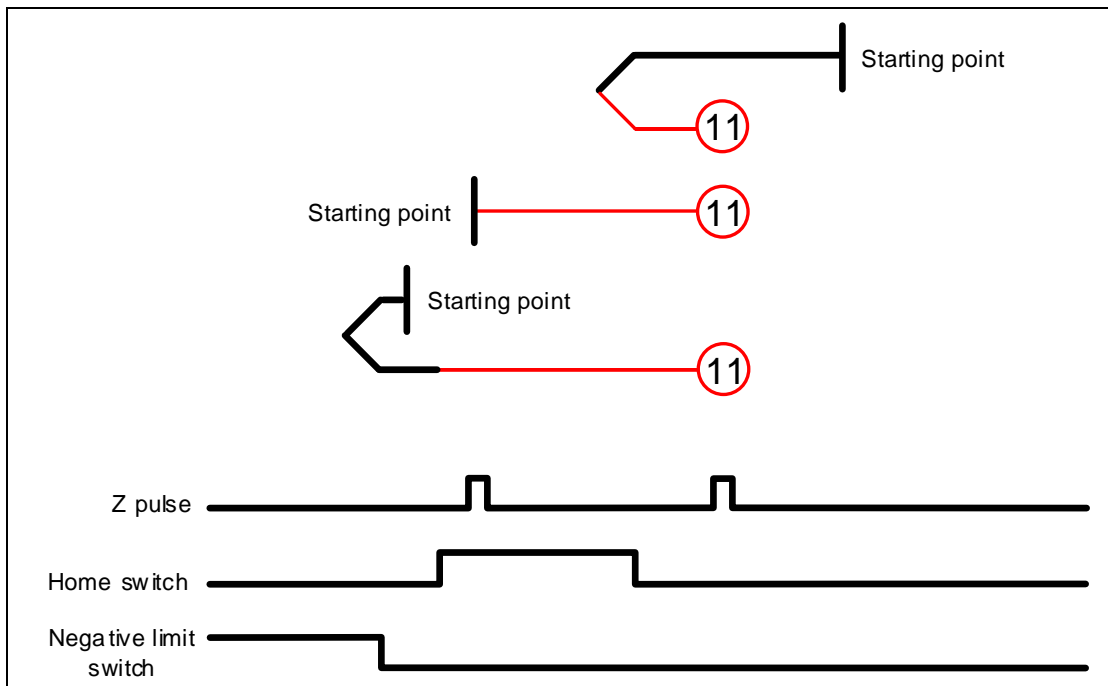

Method 12: homing on the negative limit switch, home switch, and Z pulse

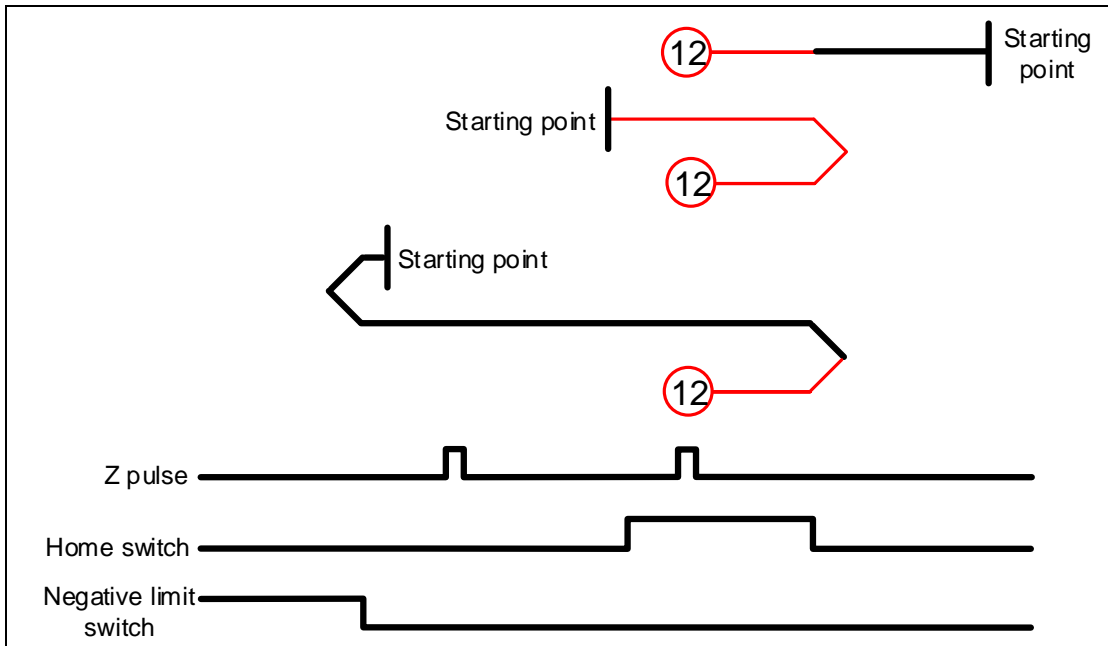

13

Method 13: homing on the negative limit switch, home switch, and Z pulse

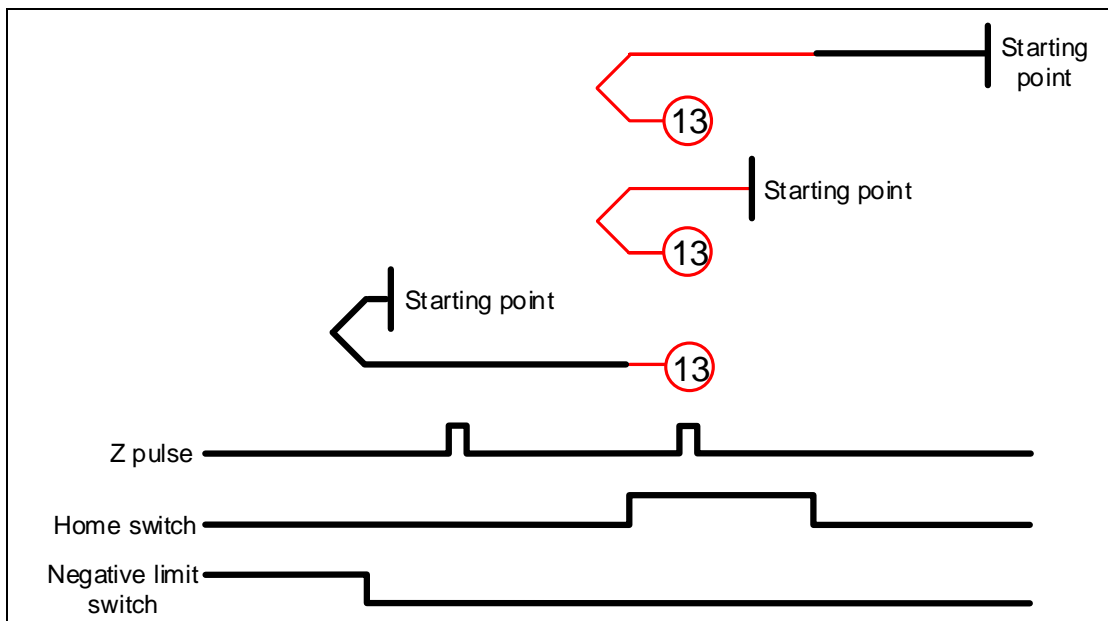



# 13

Method 14: homing on the negative limit switch, home switch, and Z pulse

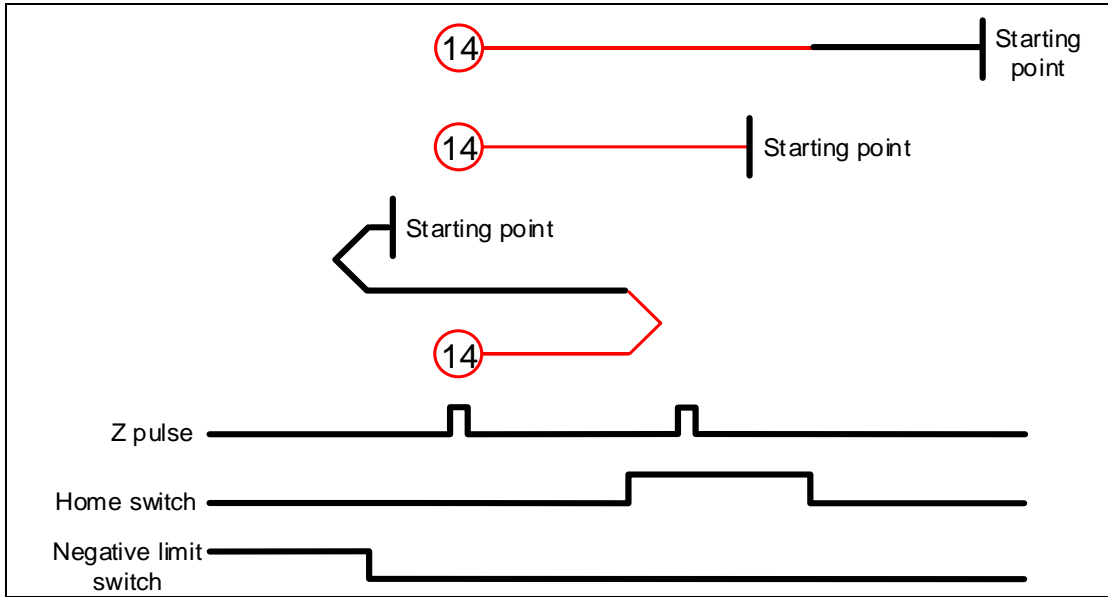

Methods 15 and 16: reserved

Method 17: homing on the negative limit switch

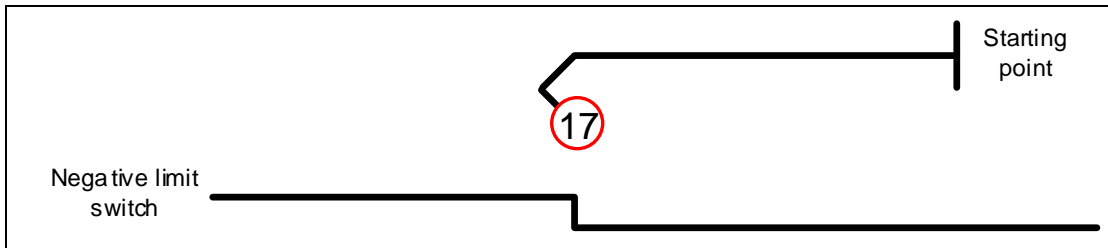

Method 18: homing on the positive limit switch

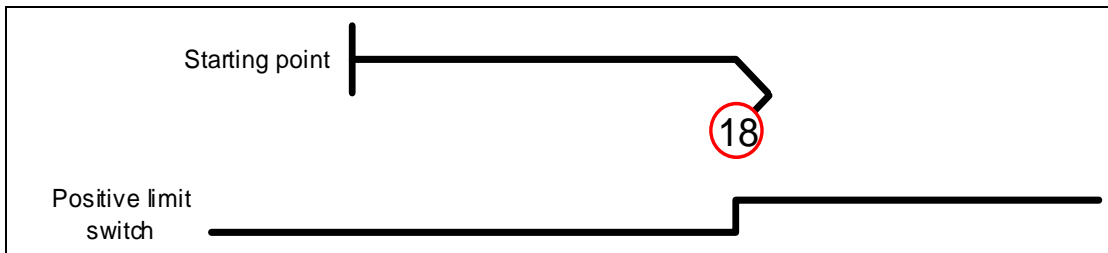

Methods 19 and 20: homing on the home switch

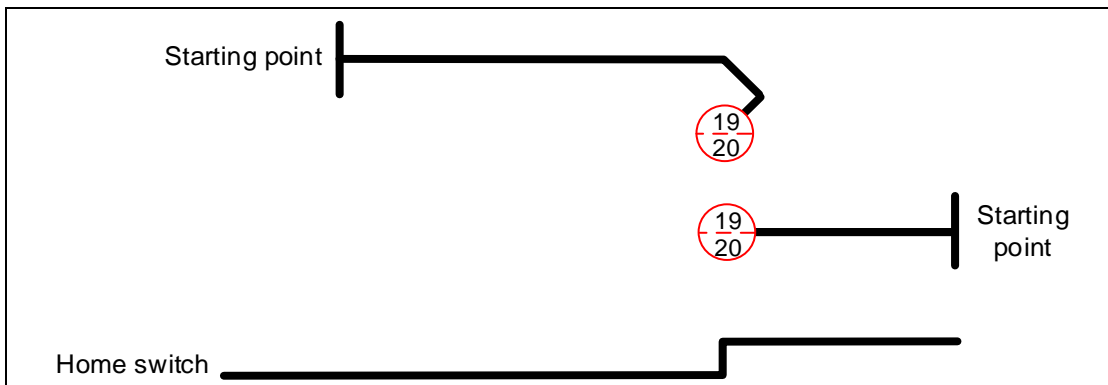

Methods 21 and 22: homing on the home switch

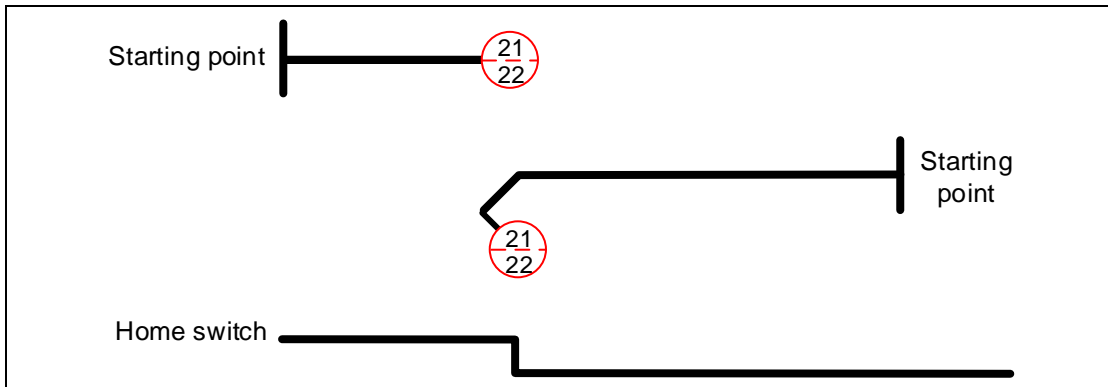

Methods 23 and 24: homing on the positive limit switch and home switch

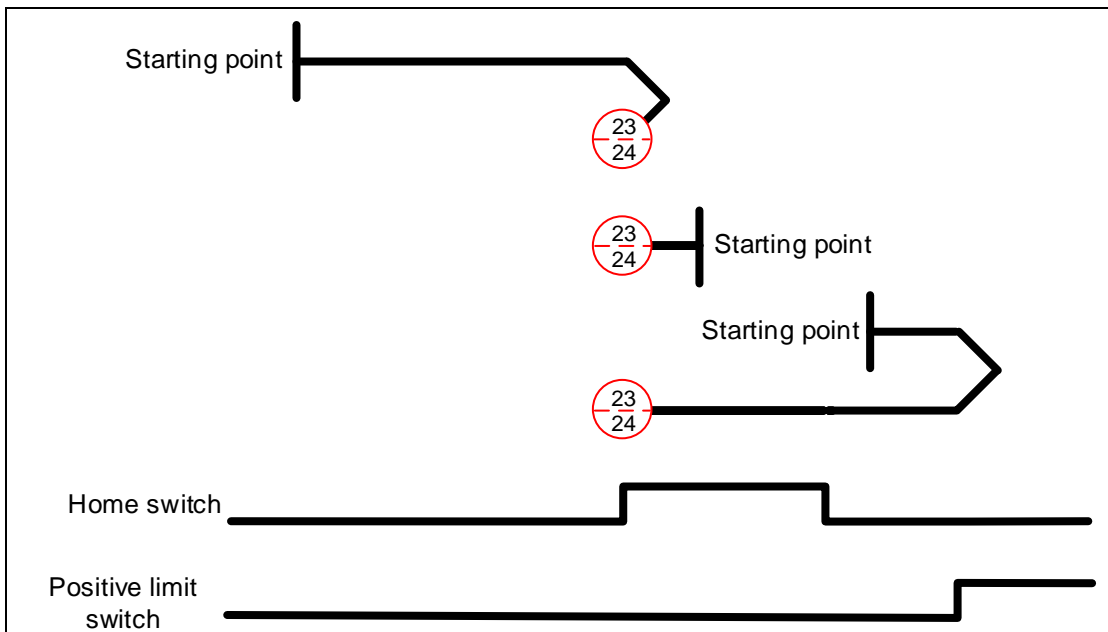

Methods 25 and 26: homing on the positive limit switch and home switch

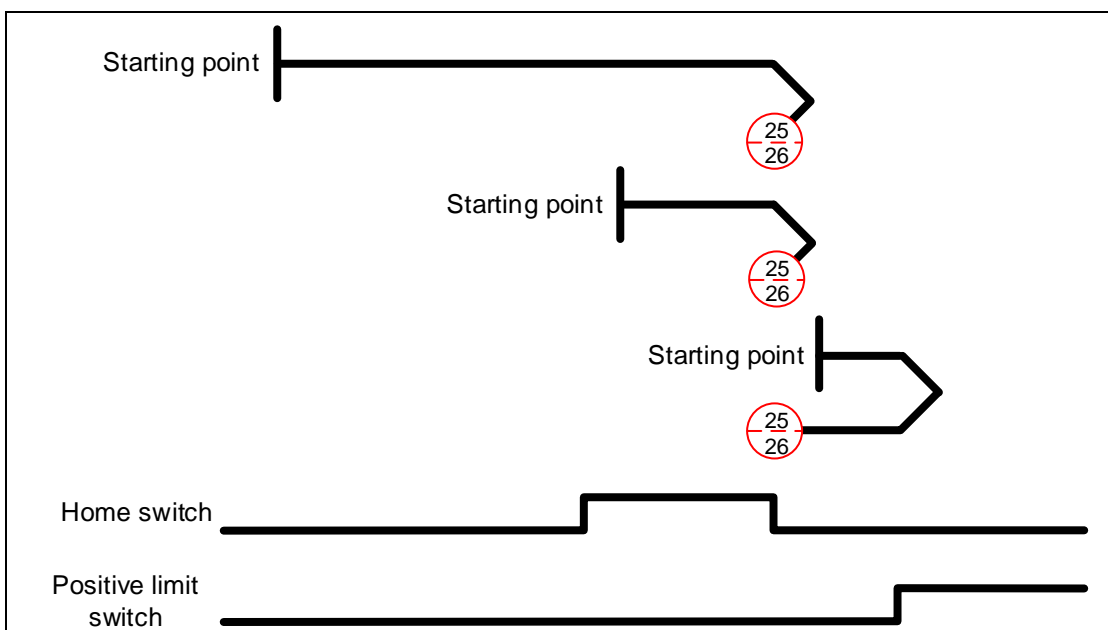

# 13

Methods 27 and 28: homing on the negative limit switch and home switch

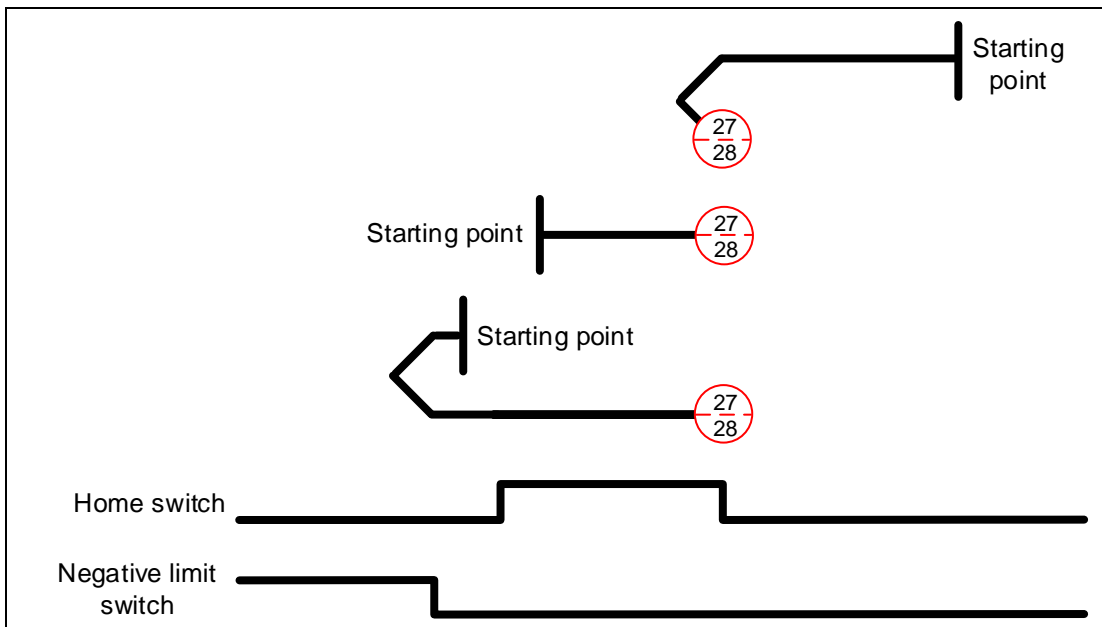

Methods 29 and 30: homing on the negative limit switch and home switch

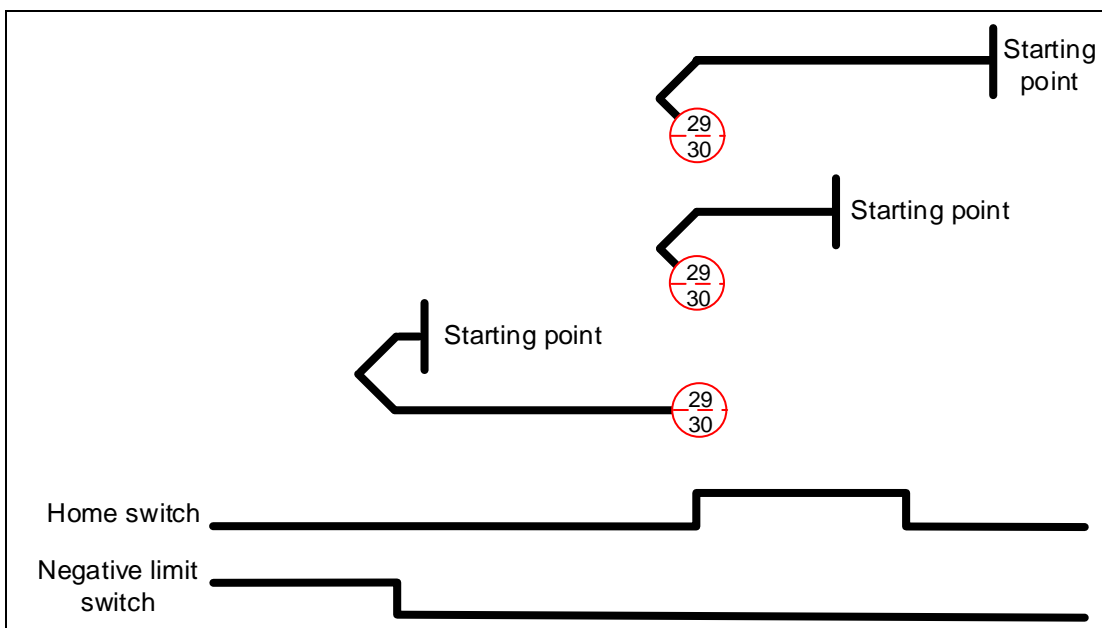

Methods 31 and 32: reserved

Methods 33 and 34: homing on the Z pulse

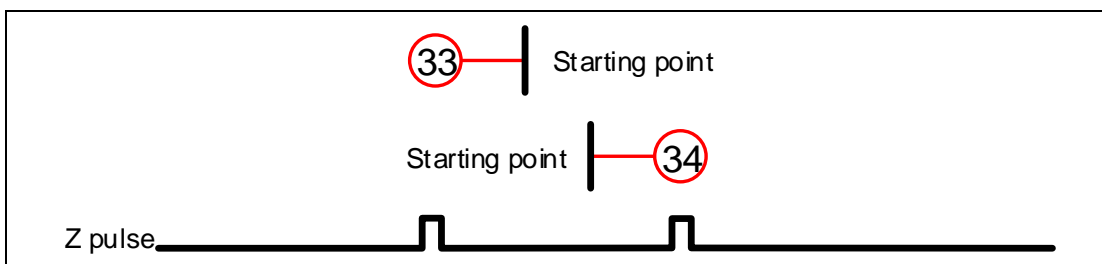

Method 35: defines the current feedback position as the origin

Methods 36 and 37:

When OD 6098h is set to -1 or -2: homing on the hard stop and Z pulse

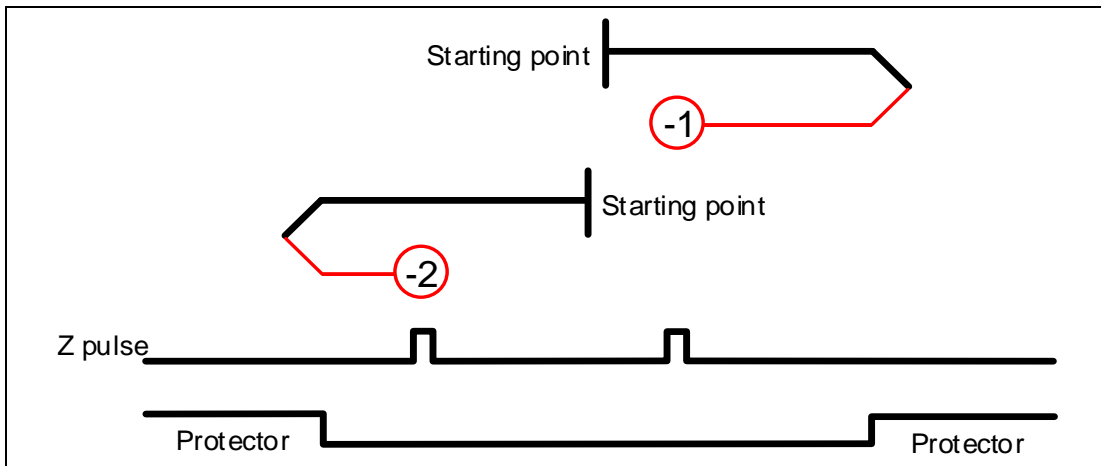

13

Methods 38 and 39:

When OD 6098h is set to -3 or -4: homing on the hard stop

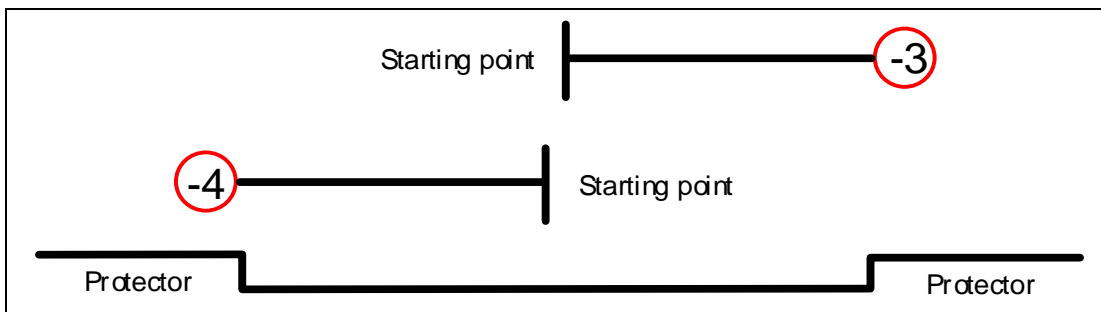

## 13

## Object 6099h: Homing speeds

Index	6099h
Name	Homing speeds
Object code	ARRAY
Data type	UNSIGNED32
Access	RW
PDO mapping	Yes

Sub-index	0
Description	Number of sub-index
Data type	UNSIGNED8
Access	RO
PDO mapping	Yes
Setting range	2
Default	2

Sub-index	1
Description	Speed during search for switch
Data type	UNSIGNED32
Access	RW
PDO mapping	Yes
Setting range	1 - 20000
Default	100
Unit	0.1 rpm (rotary motor) 1 $\mu$ m/s (linear motor)

Sub-index	2
Description	Speed during search for zero
Data type	UNSIGNED32
Access	RW
PDO mapping	Yes
Setting range	1 - 5000
Default	20
Unit	0.1 rpm (rotary motor) 1 $\mu$ m/s (linear motor)

## Object 609Ah: Homing acceleration

Index	609Ah
Name	Homing acceleration
Object code	VAR
Data type	UNSIGNED32
Access	RW
PDO mapping	Yes
Setting range	UNSIGNED32
Default	100
Unit	ms

## Object function:

The time slope set by this object is the time required for the motor to accelerate from 0 rpm to 3,000 rpm and decelerate from 3,000 rpm to 0 rpm. This object only works in Homing mode.

## Object 60B0h: Position offset

Index	60B0h
Name	Position offset
Object code	VAR
Data type	INTEGER32
Access	RW
PDO mapping	Yes
Setting range	INTEGER32
Default	0
Unit	PUU

## Object function:

This object sets the position offset. For more details, refer to Section 13.3.5 Cyclic Synchronous Position mode.

## Object 60B1h: Velocity offset

Index	60B1h
Name	Velocity offset
Object code	VAR
Data type	INTEGER32
Access	RW
PDO mapping	Yes
Setting range	INTEGER32
Default	0
Unit	0.1 rpm

## Object function:

This object sets the velocity offset. For more details, refer to Section 13.3.6 Cyclic Synchronous Velocity mode.

# 13

## Object 60B2h: Torque offset

Index	60B2h
Name	Torque offset
Object code	VAR
Data type	INTEGER16
Access	RW
PDO mapping	Yes
Setting range	-3500 to +3500
Default	0
Unit	0.1%

Object function:

This object sets the torque offset. For more details, refer to Section 13.3.7 Cyclic Synchronous Torque mode.

## Object 60B8h: Touch probe function

Index	60B8h
Name	Touch probe function
Object code	VAR
Data type	UNSIGNED16
Access	RW
PDO mapping	Yes
Setting range	UNSIGNED16
Default	0

Object function:

This object sets the Touch Probe related function settings. For the operation details, refer to Section 13.3.8 for the description of Touch Probe.

Bit	15	14	13	12	11	10	9	8	7	6	5	4	3	2	1	0
-----	----	----	----	----	----	----	---	---	---	---	---	---	---	---	---	---

Bit	Function	Description
Bit 0	Touch Probe 1 switch	0: disable Touch Probe 1. 1: enable Touch Probe 1.
Bit 1	Touch Probe 1 number of capturing times	0: capture one time. If the Touch Probe 1 signal is set to be both rising-edge and falling-edge triggered, the data is captured once for each triggering. 1: capture multiple times.
Bit 2	Touch Probe 1 capture source	0: DI1 of CN1 1: motor Z pulse
Bit 3	Reserved	-
Bit 4	Rising-edge trigger action of Touch Probe 1	0: N/A 1: start capturing when the Touch Probe 1 signal is rising-edge triggered and store the data in OD 60BAh.
Bit 5	Falling-edge trigger action of Touch Probe 1	0: N/A 1: start capturing when the Touch Probe 1 signal is falling-edge triggered and store the data in OD 60BBh.

Bit	Function	Description
Bit 6 - Bit 7	Reserved	-
Bit 8	Touch Probe 2 switch	0: disable Touch Probe 2. 1: enable Touch Probe 2.
Bit 9	Touch Probe 2 number of capturing times	0: capture one time. If the Touch Probe 2 signal is set to be both rising-edge and falling-edge triggered, the data is captured once for each triggering. 1: capture multiple times.
Bit 10	Touch Probe 2 capture source	0: DI2 of CN1
Bit 11	Reserved	-
Bit 12	Rising-edge trigger action of Touch Probe 2	0: N/A 1: start capturing when the Touch Probe 2 signal is rising-edge triggered and store the data in OD 60BCh.
Bit 13	Falling-edge trigger action of Touch Probe 2	0: N/A 1: start capturing when the Touch Probe 2 signal is falling-edge triggered and store the data in OD 60BDh.
Bit 14 - Bit 15	Reserved	-

Object 60B9h: Touch probe status

Index	60B9h
Name	Touch probe status
Object code	VAR
Data type	UNSIGNED16
Access	RO
PDO mapping	Yes
Setting range	UNSIGNED16
Default	0

Object function:

You can access the Touch Probe status with this object. For the operation details, refer to Section 13.3.8 for the description of Touch Probe.

Bit	15	14	13	12	11	10	9	8	7	6	5	4	3	2	1	0
-----	----	----	----	----	----	----	---	---	---	---	---	---	---	---	---	---

Bit	Function	Description
Bit 0	Touch Probe 1 function status	0: Touch Probe 1 disabled. 1: Touch Probe 1 enabled.
Bit 1	Touch Probe 1 rising-edge capture	0: capturing is not triggered. 1: the Touch Probe 1 signal is rising-edge triggered and the data is successfully captured.
Bit 2	Touch Probe 1 falling-edge capture	0: capturing is not triggered. 1: the Touch Probe 1 signal is falling-edge triggered and the data is successfully captured.
Bit 3 - Bit 5	Reserved	-
Bit 6	Touch Probe 1 capture source	0: DI1 of CN1 1: motor Z pulse



# 13

Bit	Function	Description
Bit 7	Touch Probe 1 signal for capturing multiple times (Available when the function of OD 60B8h [Bit 1] Number of capturing times is enabled)	The status is reversed once the capturing succeeds. Refer to Section 13.3.8 for the timing diagram in Example 3.
Bit 8	Touch Probe 2 function status	0: Touch Probe 2 disabled. 1: Touch Probe 2 enabled.
Bit 9	Touch Probe 2 rising-edge capture	0: capturing is not triggered. 1: the Touch Probe 2 signal is rising-edge triggered and the data is successfully captured.
Bit 10	Touch Probe 2 falling-edge capture	0: capturing is not triggered. 1: the Touch Probe 2 signal is falling-edge triggered and the data is successfully captured.
Bit 11 - Bit 13	Reserved	-
Bit 14	Touch Probe 2 capture source	0: DI2 of CN1
Bit 15	Touch Probe 2 signal for capturing multiple times (Available when the function of OD 60B8h [Bit 9] Number of capturing times is enabled)	The status is reversed once the capturing succeeds.

Object 60BAh: Touch probe pos1 pos value

Index	60BAh
Name	Touch probe pos1 pos value
Object code	VAR
Data type	INTEGER32
Access	RO
PDO mapping	Yes
Setting range	INTEGER32
Default	0

Object function:

For the function of this object, refer to Section 13.3.8 for the description of Touch Probe.

Object 60BBh: Touch probe pos1 neg value

Index	60BBh
Name	Touch probe pos1 neg value
Object code	VAR
Data type	INTEGER32
Access	RO
PDO mapping	Yes
Setting range	INTEGER32
Default	0

Object function:

For the function of this object, refer to Section 13.3.8 for the description of Touch Probe.

## Object 60BCh: Touch probe pos2 pos value

Index	60BCh
Name	Touch probe pos2 pos value
Object code	VAR
Data type	INTEGER32
Access	RO
PDO mapping	Yes
Setting range	INTEGER32
Default	0

Object function:

For the function of this object, refer to Section 13.3.8 for the description of Touch Probe.

## Object 60BDh: Touch probe pos2 neg value

Index	60BDh
Name	Touch probe pos2 neg value
Object code	VAR
Data type	INTEGER32
Access	RO
PDO mapping	Yes
Setting range	INTEGER32
Default	0

Object function:

For the function of this object, refer to Section 13.3.8 for the description of Touch Probe.

## Object 60C5h: Max acceleration

Index	60C5h
Name	Max acceleration
Object code	VAR
Data type	UNSIGNED32
Access	RW
PDO mapping	Yes
Setting range	1 - 65500
Default	1
Unit	ms

Object function:

The time slope set by this object is the time required for the motor to accelerate from 0 rpm to 3,000 rpm.

## 13

## Object 60C6h: Max deceleration

Index	60C6h
Name	Max deceleration
Object code	VAR
Data type	UNSIGNED32
Access	RW
PDO mapping	Yes
Setting range	1 - 65500
Default	1
Unit	ms

## Object function:

The time slope set by this object is the time required for the motor to decelerate from 3,000 rpm to 0 rpm.

## Object 60E0h: Positive torque limit

Index	60E0h
Name	Positive torque limit
Object code	VAR
Data type	UNSIGNED16
Access	RW
PDO mapping	Yes
Setting range	0 - 3000
Default	3000
Unit	0.1%

## Object function:

This object sets the positive torque limit.

## Object 60E1h: Negative torque limit

Index	60E1h
Name	Negative torque limit
Object code	VAR
Data type	UNSIGNED16
Access	RW
PDO mapping	Yes
Setting range	0 - 3000
Default	3000
Unit	0.1%

## Object function:

This object sets the negative torque limit.

Object 60F4h: Following error actual value

Index	60F4h
Name	Following error actual value
Object code	VAR
Data type	INTEGER32
Access	RO
PDO mapping	Yes
Setting range	INTEGER32
Default	0
Unit	PUU

Object function:

The following error actual value is the difference between the position demand value (OD 6062h) and position actual value (OD 6064h). For more details, refer to the architecture diagrams in Section 13.3.

Object 60FCh: Position demand value

Index	60FCh
Name	Position demand value
Object code	VAR
Data type	INTEGER32
Access	RO
PDO mapping	Yes
Setting range	INTEGER32
Default	0
Unit	pulse

Object function:

This command is generated after being processed by the servo drive filter. For more details, refer to the architecture diagrams in Section 13.3.

# 13

Object 60FDh: Digital inputs

Index	60FDh
Name	Digital inputs
Object code	VAR
Data type	UNSIGNED32
Access	RO
PDO mapping	Yes
Setting range	UNSIGNED32
Default	0
Unit	-

Object function:

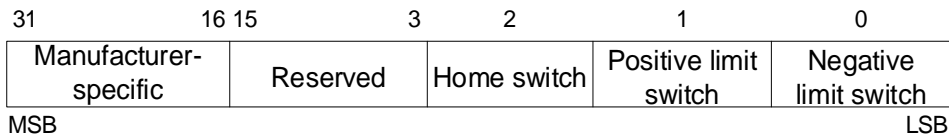

Bit	Function
Bit 0	Negative limit signal
Bit 1	Positive limit signal
Bit 2	Homing signal
Bit 3 - Bit 15	Reserved
Bit 16	DI1
Bit 17	DI2
Bit 18	DI3
Bit 19	DI4
Bit 20	DI5
Bit 21	DI6
Bit 22	DI7
Bit 23 - Bit 31	Reserved

## Object 60FEh: Digital outputs

Index	60FEh
Name	Digital outputs
Object code	ARRAY
Data type	UNSIGNED32
Access	RW

Sub-Index	0
Description	Number of sub-index
Data type	UNSIGNED8
Access	RO
PDO mapping	Yes
Setting range	2
Default	2

Sub-Index	1
Description	Physical outputs
Data type	UNSIGNED32
Access	RW
PDO mapping	Yes
Setting range	0x00000000 to 0xFFFFFFFF
Default	0

Sub-Index	2
Description	Bit mask
Data type	UNSIGNED32
Access	RW
PDO mapping	Yes
Setting range	0x00000000 to 0xFFFFFFFF
Default	0

## Object function:

## OD 60FEh sub1 Physical outputs

Bit	DO	Description
0 - 15	-	Reserved
16	DO1	0: off; 1: on
17	DO2	0: off; 1: on
18	DO3	0: off; 1: on
19	DO4	0: off; 1: on
20 - 31	-	Reserved

# 13

OD 60FEh sub2 Bit mask

Bit	DO	Description
0 - 15	-	Reserved
16	DO1	0: disable physical outputs; 1: enable
17	DO2	0: disable physical outputs; 1: enable
18	DO3	0: disable physical outputs; 1: enable
19	DO4	0: disable physical outputs; 1: enable
20 - 31	-	Reserved

- To use the software to control the DO output, you must first set the corresponding DO function code.

When P2.018 = 0x0130, the output of DO1 is controlled by the software.

When P2.019 = 0x0131, the output of DO2 is controlled by the software.

When P2.020 = 0x0132, the output of DO3 is controlled by the software.

When P2.021 = 0x0133, the output of DO4 is controlled by the software.
- DO output settings

When the corresponding OD 60FEh sub2 bit of the DO is set to 1, the output status of this DO is determined by the corresponding bit of OD 60FEh sub1.

When the corresponding OD 60FEh sub2 bit of the DO is set to 0, the output status of this DO is determined by P4.006.
- Example

  1. Set P2.018 to 0x0130, which means the output of DO1 is controlled by the software.
  2. When OD 60FEh sub2 [Bit 16] is 1, the output of DO1 is determined by 0x60FE sub1 [Bit 16]. When OD 60FEh sub2 [Bit 16] is 0, the output of DO1 is determined by P4.006 [Bit 0].

Object 60FFh: Target velocity

Index	60FFh
Name	Target velocity
Object code	VAR
Data type	INTEGER32
Access	RW
PDO mapping	Yes
Setting range	INTEGER32
Default	0
Unit	0.1 rpm

Object function:

This object sets the target velocity. This object only works in Profile Velocity mode and Cyclic Synchronous Velocity mode.

Object 6502h: Supported drive modes

Index	6502h
Name	Supported drive modes
Object code	VAR
Data type	UNSIGNED32
Access	RO
PDO mapping	Yes
Setting range	UNSIGNED32
Default	03ADh

Object function:

This object is read-only and provides the operation modes supported by Delta servo drives in EtherCAT mode.

Bit	31	30	29	28	27	26	25	24	23	22	21	20	19	18	17	16
Bit	15	14	13	12	11	10	9	8	7	6	5	4	3	2	1	0

Bit	Function
Bit 0	Profile Position mode
Bit 1	Reserved
Bit 2	Profile Velocity mode
Bit 3	Profile Torque mode
Bit 4	Reserved
Bit 5	Homing mode
Bit 6	Reserved
Bit 7	Cyclic Synchronous Position mode
Bit 8	Cyclic Synchronous Velocity mode
Bit 9	Cyclic Synchronous Torque mode
Bit 10 - Bit 31	Reserved



## 13

## 13.5 Diagnostics and troubleshooting

This section provides diagnostics and troubleshooting information related to communication or interference with the controller. For information about the servo drive alarms, refer to Chapter 14 Troubleshooting.

1. The SYNC communication cycle of the controller and servo drive is different

Since the jitter of each controller is different, the time the servo drive receives the SYNC differs from the SYNC communication cycle time. When this happens, adjust the value of P3.009.Z to increase the error range and let the servo drive automatically correct the internal timer so it is consistent with the communication cycle of the controller.

2. Eliminate interference

Packets are particularly sensitive to interference in high-speed network communication applications. To achieve fast and high-precision control, the selection of the wire is extremely important. Use shielded cables for the communication wiring, and make sure that the cable shield is firmly connected to the servo drive communication port. Also, ensure the ground wire is properly connected and grounded.

### 13.5.1 EtherCAT Diagnosis

The EtherCAT automatic error diagnostic function must be used with the ASDA-Soft software of version 6.1.2.0 or above. To use this function, activate **EtherCAT Diagnosis** in ASDA-Soft and press **Diagnosis** to get the following EtherCAT connection information for error detection.

1. Check if the servo parameter P1.001.YX is set to 0C for communication mode.
2. Port hardware detection (check if Port0 or Port1 is connected).
3. Time synchronization status (Cycle time and DC time).
4. Physical station number (Config ID) and logical station number (P3.000) information.
5. Check the content of PDO mapping to determine if the configuration is correct.
6. SM0 - SM3: the channels used by the SDO & PDO and the channel length information.
7. FMMU0 - FMMU3 configuration information.
8. EtherCAT state machine display (Init → Pre-Op → Safe-Op → Op).
9. Status display for EtherCAT communication initialization application layer (Application Layer Error Code).
10. EtherCAT communication error rate display.
11. Controlword (OD 6040h) and Statusword (OD 6041h) display.
12. EtherCAT operation mode status display (OD 6060h, 6061h, 6071h, 6072h, 6080h, 60FFh, 60E0h, 60E1h, and 607Ah)

Note: refer to the latest version of the ASDA-Soft software for the updated functions of **EtherCAT Diagnosis**.

### 13.5.2 Alarm list

Display	Alarm name	16-bit error code
AL001	Overcurrent	2310h
AL002	Overvoltage	3110h
AL003	Undervoltage	3120h
AL004	Motor combination error	7122h
AL005	Regeneration error	3210h
AL006	Overload	3230h
AL007	Excessive deviation of Speed command	8400h
AL008	Abnormal pulse command	8600h
AL009	Excessive deviation of Position command	8611h
AL010	Voltage error during regeneration	3210h
AL011	CN2 communication failed	7305h
AL012	Calibration error	6320h
AL013	Emergency stop	5441h
AL014	Negative limit error	5443h
AL015	Positive limit error	5442h
AL016	Abnormal IGBT temperature	4210h
AL017	EEPROM error	5330h
AL018	OA and OB output error	7306h
AL020	Serial communication timeout	7520h
AL022	RST power error	3130h
AL023	Early overload warning	3231h
AL024	Encoder initial magnetic field error	7305h
AL025	Encoder internal error	7305h
AL026	Encoder unreliable internal data	7305h
AL027	Encoder internal reset error	7305h
AL028	Battery voltage error or encoder internal error	7305h
AL029	Gray code error	7305h
AL02A	Number of revolutions of the encoder is in error	7305h
AL02B	Motor data error	7305h
AL02C	Servo drive overload	3230h
AL02F	Blocked rotor protection	0000h
AL030	Motor collision error	7121h
AL031	Motor power cable wiring error	3300h
AL032	Abnormal encoder vibration	7305h
AL033	26-pin connector for the position signal converter box is disconnected or motor is abnormal	7305h
AL034	Encoder internal communication error	7305h
AL035	Temperature of the encoder or external sensor exceeds the protective range	7305h
AL036	Encoder alarm status error	7305h
AL040	Excessive position error of full-closed loop control	8610h
AL041	CN5 is disconnected	7305h
AL042	Voltage input for analog Speed command is too high	FF01h
AL044	Servo function operational warning	6100h
AL045	E-Gear ratio value error	6320h
AL048	OA and OB output error	7036h

## 13

Display	Alarm name	16-bit error code
AL050	Motor parameter identification is complete	0000h
AL051	Motor parameter automatic identification error	0000h
AL052	Initial magnetic field detection error	0000h
AL053	Motor parameters are not confirmed	0000h
AL054	Parameter is out of range due to switching of motor types	0000h
AL055	Motor magnetic field error	0000h
AL056	Excessive motor speed	0000h
AL057	Feedback pulse is lost	0000h
AL058	Excessive position deviation after initial magnetic field detection is complete	0000h
AL05B	Motor type setting does not match	0000h
AL05C	Motor position feedback error	0000h
AL05D	Detection error for offset between absolute encoder zero point and motor magnetic field zero point (PM.010)	0000h
AL05E	Position signal converter box communication failure	0000h
AL060	Absolute position is lost	7305h
AL061	Encoder undervoltage	7305h
AL062	Number of revolutions of the absolute encoder overflows (issued by encoder)	7305h
AL063	Linear scale signal error	7305h
AL064	Encoder vibration warning	7305h
AL066	Number of revolutions of the absolute encoder overflows (issued by servo drive)	7305h
AL067	Encoder temperature warning	7305h
AL068	Absolute data transmitted by I/O is in error	7305h
AL069	Wrong motor type	0000h
AL06A	Absolute position is lost	7305h
AL06B	The error between the servo drive internal position and the encoder position is too large	7305h
AL06E	Encoder type is unidentifiable	7305h
AL06F	The absolute position is not established	7305h
AL070	Encoder did not complete the read / write procedure	7305h
AL071	Number of revolutions of the encoder is in error	7305h
AL072	Encoder overspeed	7305h
AL073	Encoder memory error	7305h
AL074	Encoder single-turn absolute position is in error	7305h
AL075	Encoder absolute number of revolutions is in error	7305h
AL077	Encoder internal error	7305h
AL079	Encoder parameter setting incomplete	7305h
AL07A	Encoder Z phase position is lost	7305h
AL07B	Encoder memory is busy	7305h
AL07C	Command to clear the absolute position is issued when the motor speed is over 200 rpm	7305h
AL07D	Motor stops operating when servo drive power is cycled before AL07C is cleared	7305h
AL07E	Error occurs when the encoder clears the procedure	7305h
AL07F	Encoder version error	7305h
AL083	Servo drive outputs excessive current	2310h
AL085	Regeneration setting error	3210h

Display	Alarm name	16-bit error code
AL086	Regenerative resistor overload	3110h
AL087	Hardware device error	2310h
AL088	Servo function operational alarm	0000h
AL089	Current detection interference	6100h
AL08A	Auto-tuning function - command error	7305h
AL08B	Auto-tuning function - dwell time is too short	7305h
AL08C	Auto-tuning function - inertia estimation error	7305h
AL095	Regenerative resistor is disconnected	-
AL099	DSP firmware error	5500h
AL09C	Parameter reset failed	5500h
AL0A6	Absolute positions of the servo drive and motor do not match	7305h
AL111	Buffer overflow occurs when SDO is received	8110h
AL112	Buffer overflow occurs when PDO is received	8110h
AL113	TxPDO transmission failed	8110h
AL121	Object's index does not exist when PDO is accessed	8200h
AL122	Object's sub-index does not exist when PDO is accessed	8200h
AL123	Data length error occurs when PDO is accessed	8200h
AL124	Data range error occurs when PDO is accessed	8200h
AL125	PDO object is read-only and write-protected	8200h
AL126	Specified object does not support PDO mapping	8200h
AL127	PDO object is write-protected when servo drive is on	8200h
AL128	Error occurs when PDO object is read from EEPROM	8200h
AL129	Error occurs when PDO object is written to EEPROM	8200h
AL130	Accessing address of EEPROM is out of range	8200h
AL131	EEPROM CRC calculation error	8200h
AL132	Parameter is write-protected	8200h
AL170	Bus communication timeout	8130h
AL180	Bus communication timeout	8130h
AL185	Bus hardware error	8120h
AL186	Bus data transmission error	8100h
AL201	Initialization error of object dictionary data	6310h
AL203	Second development platform - task configuration number is out of range	0203h
AL207	Parameter group of Type [8] PR is out of range	0207h
AL209	Parameter number of Type [8] PR is out of range	0209h
AL211	Parameter format setting of Type [8] PR is in error	0211h
AL213	Parameter setting of Type [8] PR is in error	0213h
AL215	Parameter written by Type [8] PR is read-only	0215h
AL217	Parameter written by Type [8] PR is write-protected when Servo On	0217h
AL219	Parameter written by Type [8] PR is write-protected	0219h
AL21B	Second development platform - memory stack is out of range	021Bh
AL21D	Second development platform - a divisor in an expression is zero in the program	021Dh
AL221	Second development platform - a non-existing mode is used	0221h

Display	Alarm name	16-bit error code
AL223	Second development platform - some commands are not allowed to be used when the servo is in the ERROR or FAULT state	0223h
AL22D	Absolute positioning cannot be executed when E-Cam is engaged	022Dh
AL231	Monitoring variable code specified by Type [8] PR is out of range	0231h
AL235	Position counter overflow warning	0235h
AL237	Rotary axis position is undefined	0237h
AL239	Second development platform - the argument of the LOOP_CMD command is out of range	0239h
AL23F	Second development platform - parameter is written to a memory address that is out of range	023Fh
AL245	PR positioning timeout	0245h
AL247	Second development platform - the MATH_ACC command called a math function that is out of range	0247h
AL249	PR path number is out of range	0249h
AL251	Second development platform - the argument of the MATH_POWER command is out of range	0251h
AL255	Second development platform - the system object ID is out of range when the object is used	0255h
AL257	Second development platform - the system object function block ID is out of range when the object is used	0257h
AL25B	Second development platform - object argument format error	025Bh
AL25F	Second development platform - an error occurred when the object dictionary is accessed	025Fh
AL261	Second development platform - commands dedicated for the master cannot be used when the master mode is not enabled	0261h
AL262	Second development platform - read / write address in the master mode is out of range	0262h
AL283	Software positive limit	5444h
AL285	Software negative limit	5445h
AL289	Position counter overflows	7305h
AL301	CANopen synchronization failure	6200h
AL302	Synchronization signal of CANopen is sent too soon	6200h
AL303	CANopen synchronization signal timeout	6200h
AL304	Invalid interpolation mode command	6200h
AL305	SYNC period error	6200h
AL35F	Emergency stop during deceleration	6200h
AL380	Position offset alarm for DO.MC_OK	6200h
AL3CF	Emergency stop	6200h
AL3E1	Communication fails to synchronize	6200h
AL3E2	Communication synchronization signal is sent too soon	6200h
AL3E3	Communication synchronization signal timeout	6200h
AL3F1	Absolute position command of the communication type servo drive is in error	6200h
AL400	Rotary axis position setting error	FF05h
AL401	NMT reset command is received when servo is on	0000h
AL404	PR special filter setting value is too great	FF07h
AL422	Write-in failed caused by power supply cut-off	0000h

Display	Alarm name	16-bit error code
AL500	STO function is enabled	9000h
AL501	SF1 lost (signal loss or signal error)	9000h
AL502	SF2 lost (signal loss or signal error)	9000h
AL503	STO self-diagnostic error	9000h
AL510	Internal parameter update program of the servo drive is abnormal	0000h
AL520	Calculation program timeout	0000h
AL521	Vibration elimination parameter error	6100h
AL555	System failure	-
AL809	PR arithmetic operation error or second development platform error	0000h
ALF21	Second development platform command error	0000h
ALF22	Password does not match	0000h
ALC31	Motor power cable disconnection	3300h
ALD00	MITUTOYO encoder - overspeed	7305h
ALD01	MITUTOYO encoder - initialization error	7305h
ALD02	MITUTOYO encoder - hardware error	7305h
ALD03	MITUTOYO encoder - absolute position detection error	7305h
ALD04	MITUTOYO encoder - sensor or read head error	7305h
ALD05	MITUTOYO encoder - sensor signal strength error	7305h
ALD06	MITUTOYO encoder - sensor signal strength warning	7305h
ALD07	MITUTOYO encoder - temperature warning	7305h
ALD08	BiSS C encoder - sensor installation error	7305h
ALD09	BiSS C encoder - sensor installation warning	7305h
ALD16	EnDat 2.2 encoder - sensor installation error	7305h
ALD17	EnDat 2.2 encoder - sensor signal strength error	7305h
ALD18	EnDat 2.2 encoder - position error	7305h
ALD19	EnDat 2.2 encoder - overvoltage	7305h
ALD20	EnDat 2.2 encoder - undervoltage	7305h
ALD21	EnDat 2.2 encoder - overcurrent	7305h
ALD22	EnDat 2.2 encoder - low battery voltage	7305h
ALD23	EnDat 2.2 encoder - frequency collision warning	7305h
ALD24	EnDat 2.2 encoder - temperature warning	7305h
ALD25	EnDat 2.2 encoder - sensor signal strength warning	7305h
ALD26	EnDat 2.2 encoder - low battery voltage warning	7305h
ALD27	EnDat 2.2 encoder - warning of the reference point error	7305h
ALD28	EnDat 2.2 encoder - cyclic mode warning	7305h
ALD29	EnDat 2.2 encoder - position limit warning	7305h
ALD30	EnDat 2.2 encoder - readiness warning	7305h
ALD31	EnDat 2.2 encoder - diagnostic warning	7305h
ALE00	Fagor encoder - CPU error	7305h
ALE01	Fagor encoder - parameter error	7305h
ALE02	Fagor encoder - CCD error	7305h
ALE03	Fagor encoder - position error	7305h
ALE04	Fagor encoder - sensor signal strength warning	7305h
ALE05	Fagor encoder - voltage warning	7305h
ALE06	Fagor encoder - overspeed warning	7305h
ALE07	Fagor encoder - temperature warning	7305h

(This page is intentionally left blank.)

13

# Troubleshooting

# 14

This chapter provides alarm descriptions and the corrective actions you can use for troubleshooting.

---

14.1	Alarm list .....	14-3
	General type.....	14-3
	STO type .....	14-5
	Communication type .....	14-6
	Motion control type .....	14-7
	Third-party communication type.....	14-9
14.2	Causes and corrective actions.....	14-10



14

There are five types of alarms: General, STO, Communication, Motion control, and Third-party communication. The detailed information is as follows.

**General type:** alarms caused by signal errors of the hardware or encoder.

**STO type:** alarms caused by STO errors.

**Communication type:** alarms caused by CANopen, DMCNET, or EtherCAT communication errors.

**Motion control type:** alarms caused by motion control command (in PR mode) errors.

**Third-party communication type:** alarms caused by errors of third-party encoders (Mitutoyo, BiSS C, EnDat 2.2, Fagor, or Nikon).

AL.nnn is the alarm format on the 7-segment display.



If the recommended alarm clearing method is DI.ARST, set DI.ARST (alarm reset) to On or P0.001 to 0 for clearing the alarm.

## 14.1 Alarm list

### General type

Display	Alarm name	Error type		Servo state	
		ALM	WARN	ON	OFF
AL001	Overcurrent	○			○
AL002	Overvoltage	○			○
AL003	Undervoltage		○		○
AL004	Motor combination error	○			○
AL005	Regeneration error	○			○
AL006	Overload	○			○
AL007	Excessive deviation of Speed command	○			○
AL008	Abnormal pulse command	○			○
AL009	Excessive deviation of Position command	○			○
AL010	Voltage error during regeneration	○			○
AL011	CN2 communication failed	○			○
AL012	Calibration error	○			○
AL013	Emergency stop		○		○
AL014	Negative limit error		○	○	
AL015	Positive limit error		○	○	
AL016	Abnormal IGBT temperature	○			○
AL017	EEPROM error	○			○
AL018	OA and OB output error	○			○
AL020	Serial communication timeout		○	○	
AL022	RST power error		○		○
AL023	Early overload warning		○	○	
AL024	Encoder initial magnetic field error	○			○
AL025	Encoder internal error	○			○
AL026	Encoder unreliable internal data	○			○
AL027	Encoder internal reset error	○			○
AL028	Battery voltage error or encoder internal error	○			○
AL029	Gray code error	○			○
AL02A	Number of revolutions of the encoder is in error	○			○
AL02B	Motor data error	○			○
AL02C	Servo drive overload	○			○
AL02F	Blocked rotor protection	○			○
AL030	Motor collision error	○			○
AL031	Motor power cable wiring error	○			○
AL032	Abnormal encoder vibration	○			○
AL033	26-pin connector for the position signal converter box is disconnected or motor is abnormal	○			○
AL034	Encoder internal communication error	○			○
AL035	Temperature of the encoder or external sensor exceeds the protective range	○			○
AL036	Encoder alarm status error	○			○
AL040	Excessive position error of full-closed loop control	○			○
AL041	CN5 is disconnected	○			○

Display	Alarm name	Error type		Servo state	
		ALM	WARN	ON	OFF
<b>AL042</b>	Voltage input for analog Speed command is too high	○			○
<b>AL044</b>	Servo function operational warning		○	○	
<b>AL045</b>	E-Gear ratio value error	○			○
<b>AL048</b>	OA and OB output error	○			○
<b>AL050</b>	Motor parameter identification is complete	○			○
<b>AL051</b>	Motor parameter automatic identification error	○			○
<b>AL052</b>	Initial magnetic field detection error	○			○
<b>AL053</b>	Motor parameters are not confirmed	○			○
<b>AL054</b>	Parameter is out of range due to switching of motor types	○			○
<b>AL055</b>	Motor magnetic field error	○			○
<b>AL056</b>	Excessive motor speed	○			○
<b>AL057</b>	Feedback pulse is lost	○			○
<b>AL058</b>	Excessive position deviation after initial magnetic field detection is complete	○			○
<b>AL05B</b>	Motor type setting does not match	○			○
<b>AL05C</b>	Motor position feedback error	○			○
<b>AL05D</b>	Detection error for offset between absolute encoder zero point and motor magnetic field zero point (PM.010)	○			○
<b>AL05E</b>	Position signal converter box communication failure	○			○
<b>AL060</b>	Absolute position is lost		○	○	
<b>AL061</b>	Encoder undervoltage		○	○	
<b>AL062</b>	Number of revolutions of the absolute encoder overflows (issued by encoder)		○	○	
<b>AL063</b>	Linear scale signal error		○	○	
<b>AL064</b>	Encoder vibration warning		○	○	
<b>AL066</b>	Number of revolutions of the absolute encoder overflows (issued by servo drive)		○	○	
<b>AL067</b>	Encoder temperature warning		○	○	
<b>AL068</b>	Absolute data transmitted by I/O is in error		○	○	
<b>AL069</b>	Wrong motor type	○			○
<b>AL06A</b>	Absolute position is lost		○	○	
<b>AL06B</b>	The error between the servo drive internal position and the encoder position is too large		○	○	
<b>AL06E</b>	Encoder type is unidentifiable	○			○
<b>AL06F</b>	The absolute position is not established		○	○	
<b>AL070</b>	Encoder did not complete the read / write procedure		○	○	
<b>AL071</b>	Number of revolutions of the encoder is in error	○			○
<b>AL072</b>	Encoder overspeed	○			○
<b>AL073</b>	Encoder memory error	○			○
<b>AL074</b>	Encoder single-turn absolute position is in error	○			○
<b>AL075</b>	Encoder absolute number of revolutions is in error	○			○
<b>AL077</b>	Encoder internal error	○			○
<b>AL079</b>	Encoder parameter setting incomplete	○			○

Display	Alarm name	Error type		Servo state	
		ALM	WARN	ON	OFF
<b>AL07A</b>	Encoder Z phase position is lost	○			○
<b>AL07B</b>	Encoder memory is busy	○			○
<b>AL07C</b>	Command to clear the absolute position is issued when the motor speed is over 200 rpm		○	○	
<b>AL07D</b>	Motor stops operating when servo drive power is cycled before AL07C is cleared	○			○
<b>AL07E</b>	Error occurs when the encoder clears the procedure	○			○
<b>AL07F</b>	Encoder version error	○			○
<b>AL083</b>	Servo drive outputs excessive current	○			○
<b>AL085</b>	Regeneration setting error	○			○
<b>AL086</b>	Regenerative resistor overload	○			○
<b>AL087</b>	Hardware device error	○			○
<b>AL088</b>	Servo function operational alarm	○			○
<b>AL089</b>	Current detection interference		○	○	
<b>AL08A</b>	Auto-tuning function - command error		○	○	
<b>AL08B</b>	Auto-tuning function - dwell time is too short		○	○	
<b>AL08C</b>	Auto-tuning function - inertia estimation error		○	○	
<b>AL095</b>	Regenerative resistor is disconnected		○	○	
<b>AL099</b>	DSP firmware error	○			○
<b>AL09C</b>	Parameter reset failed	○			○
<b>AL0A6</b>	Absolute positions of the servo drive and motor do not match		○	○	
<b>AL35F</b>	Emergency stop during deceleration		○	○	
<b>AL3CF</b>	Emergency stop		○		○
<b>AL422</b>	Write-in failed caused by power supply cut-off	○			○
<b>AL521</b>	Vibration elimination parameter error	○			○
<b>ALC31</b>	Motor power cable disconnection	○			○

Note: if the servo drive shows an alarm that is not in this table, contact the local distributor or technician.

### STO type

Display	Alarm name	Error type		Servo state	
		ALM	WARN	ON	OFF
<b>AL500</b>	STO function is enabled	○			○
<b>AL501</b>	SF1 lost (signal loss or signal error)	○			○
<b>AL502</b>	SF2 lost (signal loss or signal error)	○			○
<b>AL503</b>	STO self-diagnostic error	○			○

Note: if the servo drive shows an alarm that is not in this table, contact the local distributor or technician.

14

Communication type

Display	Alarm name	Error type		Servo state	
		ALM	WARN	ON	OFF
AL111	Buffer overflow occurs when SDO is received	○		○	
AL112	Buffer overflow occurs when PDO is received	○		○	
AL113	TxPDO transmission failed	○		○	
AL121	Object's index does not exist when PDO is accessed	○		○	
AL122	Object's sub-index does not exist when PDO is accessed	○		○	
AL123	Data length error occurs when PDO is accessed	○		○	
AL124	Data range error occurs when PDO is accessed	○		○	
AL125	PDO object is read-only and write-protected	○		○	
AL126	Specified object does not support PDO mapping	○		○	
AL127	PDO object is write-protected when servo drive is on	○		○	
AL128	Error occurs when PDO object is read from EEPROM	○		○	
AL129	Error occurs when PDO object is written to EEPROM	○		○	
AL130	Accessing address of EEPROM is out of range	○		○	
AL131	EEPROM CRC calculation error	○		○	
AL132	Parameter is write-protected	○		○	
AL170	Bus communication timeout	○		○	
AL180	Bus communication timeout	○			○
AL185	Bus hardware error	○			○
AL186	Bus data transmission error	○		○	
AL201	Initialization error of object dictionary data	○			○
AL301	CANopen synchronization failure		○	○	
AL302	Synchronization signal of CANopen is sent too soon		○	○	
AL303	CANopen synchronization signal timeout		○	○	
AL304	Invalid interpolation mode command		○	○	
AL305	SYNC period error		○	○	
AL3E1	Communication fails to synchronize		○	○	
AL3E2	Communication synchronization signal is sent too soon		○	○	
AL3E3	Communication synchronization signal timeout		○	○	
AL401	NMT reset command is received when servo is on	○			○

Note: if the servo drive shows an alarm that is not in this table, contact the local distributor or technician.

## Motion control type

Display	Alarm name	Error type		Servo state	
		ALM	WARN	ON	OFF
<b>AL203</b>	Second development platform - task configuration number is out of range		○	○	
<b>AL207</b>	Parameter group of Type [8] PR is out of range		○	○	
<b>AL209</b>	Parameter number of Type [8] PR is out of range		○	○	
<b>AL211</b>	Parameter format setting of Type [8] PR is in error		○	○	
<b>AL213</b>	Parameter setting of Type [8] PR is in error		○	○	
<b>AL215</b>	Parameter written by Type [8] PR is read-only		○	○	
<b>AL217</b>	Parameter written by Type [8] PR is write-protected when Servo On		○	○	
<b>AL219</b>	Parameter written by Type [8] PR is write-protected		○	○	
<b>AL21B</b>	Second development platform - memory stack is out of range		○	○	
<b>AL21D</b>	Second development platform - a divisor in an expression is zero in the program		○	○	
<b>AL221</b>	Second development platform - a non-existing mode is used		○	○	
<b>AL223</b>	Second development platform - some commands are not allowed to be used when the servo is in the ERROR or FAULT state		○	○	
<b>AL22D</b>	Absolute positioning cannot be executed when E-Cam is engaged		○	○	
<b>AL231</b>	Monitoring variable code specified by Type [8] PR is out of range		○	○	
<b>AL235</b>	Position counter overflow warning		○	○	
<b>AL237</b>	Rotary axis position is undefined		○	○	
<b>AL239</b>	Second development platform - the argument of the LOOP_CMD command is out of range		○	○	
<b>AL23F</b>	Second development platform - parameter is written to a memory address that is out of range		○	○	
<b>AL245</b>	PR positioning timeout		○	○	
<b>AL247</b>	Second development platform - the MATH_ACC command called a math function that is out of range		○	○	
<b>AL249</b>	PR path number is out of range		○	○	
<b>AL251</b>	Second development platform - the argument of the MATH_POWER command is out of range		○	○	
<b>AL255</b>	Second development platform - the system object ID is out of range when the object is used		○	○	
<b>AL257</b>	Second development platform - the system object function block ID is out of range when the object is used		○	○	
<b>AL25B</b>	Second development platform - object argument format error		○	○	
<b>AL25F</b>	Second development platform - an error occurred when the object dictionary is accessed		○	○	

14

Display	Alarm name	Error type		Servo state	
		ALM	WARN	ON	OFF
<b>AL261</b>	Second development platform - commands dedicated for the master cannot be used when the master mode is not enabled		○	○	
<b>AL262</b>	Second development platform - read / write address in the master mode is out of range		○	○	
<b>AL283</b>	Software positive limit		○	○	
<b>AL285</b>	Software negative limit		○	○	
<b>AL289</b>	Position counter overflows		○	○	
<b>AL380</b>	Position offset alarm for DO.MC_OK		○	○	
<b>AL3F1</b>	Absolute position command of the communication type servo drive is in error	○			○
<b>AL400</b>	Rotary axis position setting error	○			○
<b>AL404</b>	PR special filter setting value is too great	○			○
<b>AL510</b>	Internal parameter update program of the servo drive is abnormal		○	○	
<b>AL520</b>	Calculation program timeout	○			○
<b>AL555</b>	System failure	○			○
<b>AL809</b>	PR arithmetic operation error or second development platform error	○			○
<b>ALF21</b>	Second development platform command error	○			○
<b>ALF22</b>	Password does not match	○			○

Note: if the servo drive shows an alarm that is not in this table, contact the local distributor or technician.

## Third-party communication type

Display	Alarm name	Error type		Servo state	
		ALM	WARN	ON	OFF
<b>ALD00</b>	MITUTOYO encoder - overspeed	○			○
<b>ALD01</b>	MITUTOYO encoder - initialization error	○			○
<b>ALD02</b>	MITUTOYO encoder - hardware error	○			○
<b>ALD03</b>	MITUTOYO encoder - absolute position detection error	○			○
<b>ALD04</b>	MITUTOYO encoder - sensor or read head error	○			○
<b>ALD05</b>	MITUTOYO encoder - sensor signal strength error	○			○
<b>ALD06</b>	MITUTOYO encoder - sensor signal strength warning		○	○	
<b>ALD07</b>	MITUTOYO encoder - temperature warning		○	○	
<b>ALD08</b>	BiSS C encoder - sensor installation error	○			○
<b>ALD09</b>	BiSS C encoder - sensor installation warning		○	○	
<b>ALD16</b>	EnDat 2.2 encoder - sensor installation error	○			○
<b>ALD17</b>	EnDat 2.2 encoder - sensor signal strength error	○			○
<b>ALD18</b>	EnDat 2.2 encoder - position error	○			○
<b>ALD19</b>	EnDat 2.2 encoder - overvoltage	○			○
<b>ALD20</b>	EnDat 2.2 encoder - undervoltage	○			○
<b>ALD21</b>	EnDat 2.2 encoder - overcurrent	○			○
<b>ALD22</b>	EnDat 2.2 encoder - low battery voltage		○	○	
<b>ALD23</b>	EnDat 2.2 encoder - frequency collision warning		○	○	
<b>ALD24</b>	EnDat 2.2 encoder - temperature warning		○	○	
<b>ALD25</b>	EnDat 2.2 encoder - sensor signal strength warning		○	○	
<b>ALD26</b>	EnDat 2.2 encoder - low battery voltage warning		○	○	
<b>ALD27</b>	EnDat 2.2 encoder - warning of the reference point error		○	○	
<b>ALD28</b>	EnDat 2.2 encoder - cyclic mode warning		○	○	
<b>ALD29</b>	EnDat 2.2 encoder - position limit warning		○	○	
<b>ALD30</b>	EnDat 2.2 encoder - readiness warning		○	○	
<b>ALD31</b>	EnDat 2.2 encoder - diagnostic warning		○	○	
<b>ALE00</b>	Fagor encoder - CPU error	○			○
<b>ALE01</b>	Fagor encoder - parameter error	○			○
<b>ALE02</b>	Fagor encoder - CCD error	○			○
<b>ALE03</b>	Fagor encoder - position error	○			○
<b>ALE04</b>	Fagor encoder - sensor signal strength warning		○	○	
<b>ALE05</b>	Fagor encoder - voltage warning		○	○	
<b>ALE06</b>	Fagor encoder - overspeed warning		○	○	
<b>ALE07</b>	Fagor encoder - temperature warning		○	○	



14

## 14.2 Causes and corrective actions

AL001 Overcurrent	
Trigger condition and cause	<p>Condition: main circuit current is greater than 1.5 times the maximum instantaneous current of the servo drive.</p> <p>Cause:</p> <ol style="list-style-type: none"> <li>1. The servo drive output is short-circuited.</li> <li>2. Motor wiring is in error.</li> <li>3. IGBT is abnormal.</li> </ol>
Checking method and corrective action	<ol style="list-style-type: none"> <li>1. Check the connection between the motor and servo drive and make sure that the wire is not short-circuited. Do not expose the metal part of the wiring. Check if you have followed the wiring sequence for connecting the motor to the servo drive as described in this manual.</li> <li>2. If the temperature of the heat sink is abnormal, send your servo drive back to the distributor or contact Delta. Check if the set value of the parameter is much greater than the default. It is recommended that you reset the parameter to the factory default setting and then modify the setting gradually.</li> </ol>
How to clear the alarm?	Cycle power on the servo drive.

AL002 Overvoltage	
Trigger condition and cause	<p>Condition: main circuit voltage exceeds the rated value.</p> <p>Cause:</p> <ol style="list-style-type: none"> <li>1. The input voltage of the main circuit is higher than the allowable rated value.</li> <li>2. Incorrect power input (incorrect power system).</li> <li>3. Malfunction of the servo drive hardware.</li> <li>4. Incorrect selection of the regenerative resistor or no connection to an external regenerative resistor.</li> </ol>
Checking method and corrective action	<ol style="list-style-type: none"> <li>1. Use a voltmeter to check if the input voltage of the main circuit is within the allowable rated value (refer to Appendix A Specifications) and check if the power system complies with the specifications. Use the right voltage source or connect the transformer and regulator in series to have the voltage be within the specified range.</li> <li>2. If the alarm occurs when the input voltage of the main circuit measured by the voltmeter is within the allowable rated value, send your servo drive back to the distributor or contact Delta.</li> <li>3. Check the connection for the regenerative resistor, re-calculate the value for the regenerative resistor, and correctly set the values of P1.052 and P1.053.</li> </ol>
How to clear the alarm?	DI.ARST

AL003 Undervoltage	
Trigger condition and cause	<p>Condition:</p> <ol style="list-style-type: none"> <li>1. Main circuit voltage is below the rated value. The error type of AL003 is a warning by default. To set AL003 as an alarm, you can set P2.066 [Bit 9] to 1.</li> <li>2. DC Bus voltage is below <math>P4.024 \times \sqrt{2}</math>.</li> </ol> <p>Cause:</p> <ol style="list-style-type: none"> <li>1. The input voltage of the main circuit is lower than the allowable rated value.</li> <li>2. No voltage input to the main circuit.</li> <li>3. Incorrect power input (incorrect power system).</li> </ol>
Checking method and corrective action	<ol style="list-style-type: none"> <li>1. Check if the voltage wiring is correct and the wiring of input voltage for the main circuit is normal.</li> <li>2. Check the switch of the power supply and use a voltmeter to check the main circuit voltage.</li> <li>3. Use a voltmeter to check if the power system complies with the specifications. If not, use the right voltage source or connect the transformer in series.</li> </ol>
How to clear the alarm?	<p>Set P2.066 [Bit 2] to clear AL003:</p> <ol style="list-style-type: none"> <li>1. If P2.066 [Bit 2] is set to 0, use DI.ARST to clear the alarm after the voltage is back in the normal range.</li> <li>2. If P2.066 [Bit 2] is set to 1, the alarm is automatically cleared once the voltage is back in the normal range.</li> </ol>

AL004 Motor combination error	
Trigger condition and cause	<p>Condition: an incorrect motor is used with the servo drive.</p> <p>Cause:</p> <ol style="list-style-type: none"> <li>1. Motor combination error (the servo drive is connected to the wrong motor).</li> <li>2. The encoder connector is loose.</li> <li>3. The encoder is damaged.</li> </ol>
Checking method and corrective action	<ol style="list-style-type: none"> <li>1. Use the right motor.</li> <li>2. Check and re-install the encoder connector.</li> <li>3. If the encoder (motor) is not operating properly, replace the motor.</li> </ol>
How to clear the alarm?	<p>Cycle power on the servo drive.</p>

AL005 Regeneration error	
Trigger condition and cause	<p>Condition: an error occurs during regeneration.</p> <p>Cause:</p> <ol style="list-style-type: none"> <li>1. Incorrect selection of the regenerative resistor or no connection to an external regenerative resistor.</li> <li>2. P1.053 (Regenerative resistor capacity) is not set to 0 when the regenerative resistor is not connected.</li> <li>3. Incorrect parameter settings for P1.052 and P1.053.</li> </ol>
Checking method and corrective action	<ol style="list-style-type: none"> <li>1. Check the connection for the regenerative resistor, re-calculate the value for the regenerative resistor, and correctly set the values of P1.052 and P1.053. If the issue persists, send your servo drive back to Delta.</li> <li>2. Set P1.053 to 0 if not using a regenerative resistor.</li> <li>3. Correctly set the regenerative resistor value (P1.052) and the regenerative resistor capacity (P1.053).</li> </ol>
How to clear the alarm?	DI.ARST

AL006 Overload	
Trigger condition and cause	<p>Condition: overload of motor and servo drive.</p> <p>Cause:</p> <ol style="list-style-type: none"> <li>1. The load is over the rated range and the servo drive is in a continuous overload condition.</li> <li>2. Improper parameter settings.</li> <li>3. Incorrect motor wiring.</li> <li>4. Encoder is in error.</li> </ol>
Checking method and corrective action	<ol style="list-style-type: none"> <li>1. Set P0.002 to 12 for monitoring if the average load rate [%] is continuously over 100%. If so, increase the motor capacity or reduce the load. Refer to Appendix A for Graph of load and operating time.</li> <li>2. Check if there is any mechanical vibration or the setting for acceleration or deceleration is too drastic.</li> <li>3. Check if the wiring of the motor power cable and encoder cable is correct.</li> <li>4. Send the motor back to the distributor or contact Delta.</li> </ol>
How to clear the alarm?	DI.ARST

<b>AL007 Excessive deviation of Speed command</b>	
Trigger condition and cause	<p>Condition: difference between the command speed and the feedback speed exceeds the allowable range set by P2.034.</p> <p>Cause:</p> <ol style="list-style-type: none"> <li>1. A drastic change in the input Speed command.</li> <li>2. Improper setting of P2.034 (Excessive deviation warning condition of Speed command).</li> <li>3. Incorrect wiring of the UVW and encoder cables.</li> </ol>
Checking method and corrective action	<ol style="list-style-type: none"> <li>1. Use the signal detector to check if the input analog voltage signal is normal. If not, adjust the rate of change for input signals or enable the filter function.</li> <li>2. Check if the value of P2.034 (Excessive deviation warning condition of Speed command) is set properly.</li> <li>3. Check if the wiring of the motor power cable and encoder cable is correct.</li> </ol>
How to clear the alarm?	DI.ARST

<b>AL008 Abnormal pulse command</b>	
Trigger condition and cause	<p>Condition: the input frequency of the pulse command is over the allowable value for the hardware interface.</p> <p>Cause: the pulse command frequency is higher than the rated input frequency.</p>
Checking method and corrective action	Use the scope to check if the input frequency is higher than the rated input frequency and correctly set the input pulse frequency.
How to clear the alarm?	DI.ARST

<b>AL009 Excessive deviation of Position command</b>	
Trigger condition and cause	<p>Condition: difference between the command position and the feedback position exceeds the allowable range set by P2.035.</p> <p>Cause:</p> <ol style="list-style-type: none"> <li>1. The maximum position deviation is set too low.</li> <li>2. Gain value is set too low.</li> <li>3. Torque limit or speed limit is set too low.</li> <li>4. Excessive external load.</li> <li>5. Improper setting for the E-Gear ratio.</li> <li>6. The power cable is loose.</li> <li>7. The maximum speed limit is set too low.</li> </ol>

# 14

AL009 Excessive deviation of Position command	
Checking method and corrective action	<ol style="list-style-type: none"> <li>1. Check the set value of P2.035 (Excessive deviation of Position command warning). If the value is too low, set a higher value.</li> <li>2. Check if the gain value is appropriate for the application.</li> <li>3. When the speed and torque limit functions are not needed, disable P1.002; otherwise, check if the internal speed limit (P1.009 - P1.011) and internal torque limit (P1.012 - P1.014) are set correctly.</li> <li>4. Check the external load. Reduce the external load or re-evaluate the motor capacity if necessary.</li> <li>5. Check if the settings for P1.044 and P1.045 are appropriate for the application. If not, set them to proper values.</li> <li>6. Check if the power cable is loose.</li> <li>7. Check if the set value of P1.055 (Maximum speed limit) is too low.</li> </ol>
How to clear the alarm?	DI.ARST

AL010 Voltage error during regeneration	
Trigger condition and cause	<p>Condition: an error occurs during regeneration.</p> <p>Cause:</p> <ol style="list-style-type: none"> <li>1. The regenerative voltage remains at 400V for a period of time during regeneration. This may be caused by using an incorrect regenerative resistor or not connecting an external regenerative resistor to the servo drive.</li> <li>2. P1.053 (Regenerative resistor capacity) is not set to 0 when the regenerative resistor is not connected.</li> </ol>
Checking method and corrective action	<ol style="list-style-type: none"> <li>1. Check the connection for the regenerative resistor, re-calculate the value for the regenerative resistor, and correctly set the values of P1.052 and P1.053. If the issue persists, send your servo drive back to Delta.</li> <li>2. Set P1.053 to 0 if not using a regenerative resistor.</li> </ol>
How to clear the alarm?	DI.ARST

AL011 CN2 communication failed	
Trigger condition and cause	<p>Condition: connection to the encoder is in error.</p> <p>Cause:</p> <ol style="list-style-type: none"> <li>1. CN2 wiring is incorrect.</li> <li>2. CN2 connector is loose.</li> <li>3. CN2 wiring is poor.</li> <li>4. Connection to the encoder is cut off due to interference.</li> <li>5. Encoder is damaged.</li> <li>6. A motor not supported by the A3 series servo drives is used.</li> </ol>
Checking method and corrective action	<ol style="list-style-type: none"> <li>1. Check if the wiring follows the instructions in the user manual. If not, connect the wire correctly.</li> <li>2. Check the connection between the CN2 port of the servo drive and the CN2 connector. If the connection is loose, reconnect the CN2 connector to the CN2 port of the servo drive.</li> <li>3. Check for the encoder cable and connector which connect the motor and CN2 port of the servo drive to see if there is any poor wiring or damaged wires. If so, replace the connector and cable.</li> <li>4. Check the communication error rate by setting P0.002 to -80. If this value increases continuously, it means there is interference. Check the following items:               <ol style="list-style-type: none"> <li>(a) Check if the motor is properly grounded. Make sure the ground end (green) of the power cable is grounded to the servo drive heat sink.</li> <li>(b) Check if the connection for the encoder signal cable is normal. Make sure the encoder signal cable is separated from the power supply or any high-current cables to avoid interference.</li> <li>(c) Use shielded cable for the encoder cable. Pull out the wire mesh and have it correctly grounded.</li> </ol> </li> <li>5. If you took all corrective actions but the issue persists, replace the motor.</li> <li>6. Contact the distributor for the supported motor models or encoder specifications.</li> </ol>
How to clear the alarm?	<p>Cycle power on the servo drive.</p>

<b>AL012 Calibration error</b>	
Trigger condition and cause	<p>Condition: the calibration value exceeds the allowable value during electrical calibration.</p> <p>Cause:</p> <ol style="list-style-type: none"> <li>1. The analog input contact is not correctly returned to zero.</li> <li>2. The detection device is damaged.</li> </ol>
Checking method and corrective action	<ol style="list-style-type: none"> <li>1. Check if the voltage level at the analog input contact is the same as the ground potential.</li> <li>2. Cycle power and execute the calibration again. If the issue persists after power cycling, send your servo drive back to the distributor or contact Delta.</li> </ol>
How to clear the alarm?	Remove the connection cable for CN1 and then execute auto calibration.

<b>AL013 Emergency stop</b>	
Trigger condition and cause	The emergency stop button is pressed.
Checking method and corrective action	Make sure the emergency stop button is off.
How to clear the alarm?	Set DI.EMGS to off to clear the alarm.

<b>AL014 Negative limit error</b>	
Trigger condition and cause	<p>Condition: negative limit switch is triggered.</p> <p>Cause:</p> <ol style="list-style-type: none"> <li>1. Negative limit switch is triggered.</li> <li>2. Servo system is unstable.</li> </ol>
Checking method and corrective action	<ol style="list-style-type: none"> <li>1. Make sure the negative limit switch is off.</li> <li>2. Check the parameter setting or re-estimate the motor capacity.</li> </ol>
How to clear the alarm?	The alarm is automatically cleared after the motor moves away from the limit.

<b>AL015 Positive limit error</b>	
Trigger condition and cause	<p>Condition: positive limit switch is triggered.</p> <p>Cause:</p> <ol style="list-style-type: none"> <li>1. Positive limit switch is triggered.</li> <li>2. Servo system is unstable.</li> </ol>
Checking method and corrective action	<ol style="list-style-type: none"> <li>1. Make sure the positive limit switch is off.</li> <li>2. Check the parameter setting or re-estimate the motor capacity.</li> </ol>
How to clear the alarm?	The alarm is automatically cleared after the motor moves away from the limit.

<b>AL016 Abnormal IGBT temperature</b>	
Trigger condition and cause	<p>Condition: temperature of IGBT is abnormal.</p> <p>Cause:</p> <ol style="list-style-type: none"> <li>1. The load is over the rated range and the servo drive is in a continuous overload condition.</li> <li>2. The servo drive output is short-circuited.</li> </ol>
Checking method and corrective action	<ol style="list-style-type: none"> <li>1. Check for servo drive overload or motor overcurrent. If so, try increasing the motor's capacity or reducing the load.</li> <li>2. Check if the wiring of servo drive output is correct.</li> </ol>
How to clear the alarm?	DI.ARST
<b>AL017 EEPROM error</b>	
Trigger condition and cause	<p>Condition: error occurs when DSP accesses EEPROM.</p> <p>Cause:</p> <ol style="list-style-type: none"> <li>1. Parameter writing error or the value exceeds the allowable range.</li> <li>2. When power is supplied to the servo drive, the data in ROM is damaged or there is no data in ROM.</li> </ol>
Checking method and corrective action	<p>Press the SHIFT key to have the panel display EXGAB.</p> <p>X = 1, 2, 3</p> <p>G = Group number of the parameter</p> <p>AB = Parameter number in hexadecimal format</p> <p>If the panel displays "E320A", it indicates parameter P2.010. If the panel displays "E3610", it indicates parameter P6.016. Check the value for the corresponding parameter.</p> <ol style="list-style-type: none"> <li>1. The panel displays the parameter code. If this alarm occurs when power is supplied to the drive, it means a parameter value has exceeded the range. Modify the value and then cycle power on the servo drive. If the alarm occurs during normal operation, it means an error occurred when the parameter is written. Use DI.ARST to clear this alarm.</li> <li>2. The panel displays "E100X" or "E0001". If this alarm occurs when power is supplied to the drive, it is usually because the data in ROM is damaged or there is no data in ROM. Send your servo drive back to the distributor or contact Delta.</li> </ol>
How to clear the alarm?	If this alarm occurs when the drive is started, reset the parameters and then cycle the power. If the alarm occurs during operation, set DI.ARST to on.



14

AL018 OA and OB output error	
Trigger condition and cause	<p>Condition: the output frequency of the OA and OB pulses is higher than the maximum output frequency of the hardware.</p> <p>Cause:</p> <ol style="list-style-type: none"> <li>1. The resolution of the OA and OB pulses is set too high.</li> <li>2. There is interference or cable damage causing communication error.</li> <li>3. Encoder error.</li> </ol>
Checking method and corrective action	<ol style="list-style-type: none"> <li>1. The settings of P1.076 and P1.046 should follow these requirements:  <math display="block">P1.076 &gt; \text{motor speed} \text{ and } \frac{\text{Motor speed}}{60} \times P1.046 \times 4 &lt; 19.8 \times 10^6</math> </li> <li>2. Check the communication error rate by setting P0.002 to -80. If this value increases continuously, it means there is interference. Check the following items:             <ol style="list-style-type: none"> <li>(a) Check if the motor is properly grounded. Make sure the ground end (green) of the power cable is grounded to the servo drive heat sink.</li> <li>(b) Check if the connection for the encoder signal cable is normal. Make sure the encoder signal cable is separated from the power supply or any high-current cables to avoid interference.</li> <li>(c) Use shielded cable for the encoder cable. Pull out the wire mesh and have it correctly grounded.</li> </ol> </li> <li>3. Check the fault record (P4.000 - P4.004) and see if an alarm has occurred (AL011, AL024, AL025, or AL026). Use the checking methods and corrective actions to clear the alarm if any of them occurs.</li> <li>4. If you do not need to use the OA and OB pulses, set P2.065 [Bit 13] to 1 to disable the detection function for OA and OB output error (AL018 / AL048).</li> </ol>
How to clear the alarm?	<ol style="list-style-type: none"> <li>1. DI.ARST</li> <li>2. Contact the distributor.</li> </ol>

<b>AL020 Serial communication timeout</b>	
Trigger condition and cause	<p>Condition: RS-485 communication error.</p> <p>Cause:</p> <ol style="list-style-type: none"> <li>1. Improper setting for P3.004 (Modbus communication timeout).</li> <li>2. Servo drive has not received the communication command for a long time and has timed out (refer to P3.004).</li> </ol>
Checking method and corrective action	<ol style="list-style-type: none"> <li>1. Check and correctly set the value for the communication timeout parameter.</li> <li>2. Check if the communication cable is loose or disconnected and make sure it is correctly wired.</li> </ol>
How to clear the alarm?	DI.ARST
<b>AL022 RST power error</b>	
Trigger condition and cause	<p>Condition: RST power cable is loose or there is no power. The error type of AL022 is a warning by default. To set AL022 as an alarm, you can set P2.066 [Bit 12] to 1.</p> <p>Cause: RST power error.</p>
Checking method and corrective action	<p>Check if the RST power cable is loose or there is no power. For 1.5 kW (or below) ASDA-A3 servo drives, this alarm occurs when all three phases are not connected to the power supply. For 2 kW (or above) ASDA-A3 servo drives, this alarm occurs when one single phase is not connected to the power supply. Correctly connect the power to the servo drive. If the issue persists, send your servo drive back to the distributor or contact Delta.</p>
How to clear the alarm?	DI.ARST
<b>AL023 Early overload warning</b>	
Trigger condition and cause	Early overload warning.
Checking method and corrective action	<ol style="list-style-type: none"> <li>1. Check if the motor is overloaded and refer to the corrective actions for AL006 for troubleshooting.</li> <li>2. Check if the value of P1.056 (Motor output overload warning level) is set too low. If so, set the value higher, or set the value greater than 100 to disable the warning function.</li> </ol>
How to clear the alarm?	DI.ARST

AL024 Encoder initial magnetic field error	
Trigger condition and cause	<p>Condition: the magnetic field of the encoder U, V, W signal is in error.</p> <p>Cause: the initial magnetic field of the encoder is in error (magnetic field of the encoder U, V, W signal is in error.)</p>
Checking method and corrective action	<ol style="list-style-type: none"> <li>1. Check if the motor is properly grounded. Make sure the ground end (green) of the power cable is grounded to the servo drive heat sink.</li> <li>2. Check if the connection for the encoder signal cable is normal. Make sure the encoder signal cable is separated from the power supply or any high-current cables to avoid interference.</li> <li>3. Use shielded cable for the encoder cable. Pull out the wire mesh and have it correctly grounded.</li> <li>4. If using a linear motor, check the wiring noise interference. For the noise filter of the converter box, refer to PM.003. For the noise filter of the CN5 position feedback signal connector, refer to P1.074.</li> <li>5. Check the Hall sensor wiring of the linear motor and monitor the Hall sensor phase sequence by entering "0x1B42F" in the address field of the software scope.</li> </ol> <p>If the issue persists, send your servo motor back to the distributor or contact Delta.</p>
How to clear the alarm?	Cycle power on the servo drive.

AL025 Encoder internal error	
Trigger condition and cause	<p>Condition: internal memory and counter of the encoder are in error.</p> <p>Cause:</p> <ol style="list-style-type: none"> <li>1. Encoder internal error (internal memory and counter are in error).</li> <li>2. When power is applied, the motor rotates because of the inertia of the mechanical parts or other causes.</li> </ol>
Checking method and corrective action	<ol style="list-style-type: none"> <li>1. If there is interference, check the following items:                         <ol style="list-style-type: none"> <li>(a) Check if the motor is properly grounded. Make sure the ground end (green) of the power cable is grounded to the servo drive heat sink.</li> <li>(b) Check if the connection for the encoder signal cable is normal. Make sure the encoder signal cable is separated from the power supply or any high-current cables to avoid interference.</li> <li>(c) Use shielded cable for the encoder cable. Pull out the wire mesh and have it correctly grounded.</li> </ol> </li> <li>2. Make sure the motor shaft does not move when power is turned on.</li> </ol>
How to clear the alarm?	Cycle power on the servo drive.

<b>AL026 Encoder unreliable internal data</b>	
Trigger condition and cause	<p>Condition: internal data error occurs three consecutive times.</p> <p>Cause:</p> <ol style="list-style-type: none"> <li>1. External interference.</li> <li>2. Malfunction of the encoder hardware.</li> </ol>
Checking method and corrective action	<p>If there is interference, check the following items:</p> <ol style="list-style-type: none"> <li>1. Check if the motor is properly grounded. Make sure the ground end (encl) of the power cable is grounded to the servo drive heat sink.</li> <li>2. Check if the connection for the encoder signal cable is normal. Make sure the encoder signal cable is separated from the power supply or any high-current cables to avoid interference.</li> <li>3. Use shielded cable for the encoder cable. Pull out the wire mesh and have it correctly grounded.</li> <li>4. Check the communication error rate by setting P0.002 to -80. If the value is greater than 0 and increases continuously, check the previous three items again. If the value is 0, send your servo motor back to the distributor or contact Delta.</li> </ol>
How to clear the alarm?	Cycle power on the servo drive.

<b>AL027 Encoder internal reset error</b>	
Trigger condition and cause	<p>Condition: encoder reset error.</p> <p>Cause: encoder reset.</p>
Checking method and corrective action	<ol style="list-style-type: none"> <li>1. Check if there is poor connection for the encoder signal cable.</li> <li>2. Check if the power supply for the encoder is stable and make sure to use shielded cable.</li> <li>3. Check if the operating temperature is over 95°C (203°F). Identify the cause for the high temperature and do not restart the operation before the temperature drops to the allowable range.</li> </ol> <p>If the issue persists, send your servo motor back to the distributor or contact Delta.</p>
How to clear the alarm?	Cycle power on the servo drive.

14

<b>AL028 Battery voltage error or encoder internal error</b>	
Trigger condition and cause	<p>Condition: battery voltage is higher than the specification (&gt; 3.8V) or the encoder signal is in error.</p> <p>Cause:</p> <ol style="list-style-type: none"> <li>1. Voltage level of the battery is too high.</li> <li>2. Encoder internal error.</li> </ol>
Checking method and corrective action	<ol style="list-style-type: none"> <li>1. Check if there is a charging circuit. Avoid incorrect wiring. If Pin 1 (5V) of CN2 is connected to BAT+ of the encoder connector, it means the power (5V) of the servo drive is being charged to the battery.</li> <li>2. Check if the battery is correctly installed (voltage &gt; 3.8V).</li> <li>3. Check if the motor is properly grounded. Make sure the ground end (green) of the power cable is grounded to the servo drive heat sink.</li> <li>4. Check if the connection for the encoder signal cable is normal. Make sure the encoder signal cable is separated from the power supply or any high-current cables to avoid interference.</li> <li>5. Use shielded cable for the encoder. Pull out the wire mesh and have it correctly grounded.</li> </ol> <p>If the issue persists, send your servo drive and motor back to the distributor or contact Delta.</p>
How to clear the alarm?	Cycle power on the servo drive.

<b>AL029 Gray code error</b>	
Trigger condition and cause	Absolute position within a single revolution is in error.
Checking method and corrective action	Cycle power on the servo drive to operate the motor. Then, check if the alarm occurs again. If the issue persists, replace the encoder.
How to clear the alarm?	Cycle power on the servo drive.

<b>AL02A Number of revolutions of the encoder is in error</b>	
Trigger condition and cause	<p>Condition: the number of revolutions of the encoder is in error.</p> <p>Cause: the internal signal of the encoder is abnormal causing error in the number of revolutions.</p>
Checking method and corrective action	Send your servo motor back to the distributor or contact Delta.
How to clear the alarm?	N/A

<b>AL02B Motor data error</b>	
Trigger condition and cause	Accessing the internal data of the motor is in error.
Checking method and corrective action	Send your servo motor back to Delta.
How to clear the alarm?	N/A

<b>AL02C Servo drive overload</b>	
Trigger condition and cause	<p>Condition: servo drive is overloaded.</p> <p>Cause:</p> <ol style="list-style-type: none"> <li>1. The load is over the rated range and the servo drive is in a continuous overload condition.</li> <li>2. Improper setting for the gain parameters or the motion profile of the control system.</li> <li>3. Motor wiring error.</li> <li>4. The encoder is damaged or malfunctioning.</li> </ol>
Checking method and corrective action	<ol style="list-style-type: none"> <li>1. Set P0.002 = 55 to monitor the current feedback. Check if the motor current exceeds the rated output current of the servo drive for a long period of time.</li> <li>2. (a) Check if there is any mechanical vibration. If so, properly adjust the gain parameters. (b) Set a higher acceleration / deceleration time constant or a lower target speed.</li> <li>3. Check if the wiring of the motor power cable and encoder cable is correct.</li> <li>4. Replace the encoder.</li> </ol>
How to clear the alarm?	DI.ARST

<b>AL02F Blocked rotor protection</b>	
Trigger condition and cause	<p>Condition: the servo drive is overloaded, and the motor speed keeps at 10 rpm (or below) or the rotor is blocked.</p> <p>Cause:</p> <ol style="list-style-type: none"> <li>1. The motor or the connected mechanical part is locked, causing the motor not to rotate.</li> <li>2. The motor is running at an extremely low speed or the rotor is blocked for a long time.</li> </ol>

<b>AL02F Blocked rotor protection</b>	
Checking method and corrective action	<ol style="list-style-type: none"> <li>1. Set the motor speed higher to shorten the duration of the occurrence of blocked rotor.</li> <li>2. Check if the mechanical part connected to the motor is working normally.</li> <li>3. Check if the wiring of the motor power cable and encoder cable is correct.</li> <li>4. Send your servo motor back to the distributor or contact Delta.</li> </ol>
How to clear the alarm?	DI.ARST

<b>AL030 Motor collision error</b>	
Trigger condition and cause	<p>Condition: when the motor hits the device, the torque reaches the value set by P1.057 and the duration exceeds the time set by P1.058.</p> <p>Cause:</p> <ol style="list-style-type: none"> <li>1. Check if the protection function of motor hard stop (P1.057) is enabled. If so, set P1.057 to 0.</li> <li>2. Check if the value set by P1.057 is too low and the time set by P1.058 is too short. Set P1.057 according to the actual torque. If P1.057 is set to low, it may lead to malfunction; if P1.057 is set to high, it may lose the protection function.</li> </ol>
Checking method and corrective action	Cycle power on the servo drive to operate the motor. Then, check if the alarm occurs again. If the issue persists, replace the encoder.
How to clear the alarm?	DI.ARST

<b>AL031 Motor power cable wiring error</b>	
Trigger condition and cause	<p>Condition: incorrect wiring of the motor power cable (U, V, W) and ground wire (GND).</p> <p>Cause: incorrect wiring of the power cable (U, V, W) and ground wire (GND). The switch for wiring error detection is set by P2.065 [Bit 8], which is enabled by default.</p>
Checking method and corrective action	Check if the wiring of the motor power cable (U, V, W) and ground wire (GND) is correct. Follow the instructions in this user manual for correct wiring and proper grounding.
How to clear the alarm?	Cycle power on the servo drive.

<b>AL032 Abnormal encoder vibration</b>	
Trigger condition and cause	<p>Condition: abnormal vibration occurred in the encoder.</p> <p>Cause: the internal signal or mechanical part of the encoder is abnormal, so the encoder returns an error signal.</p>

<b>AL032 Abnormal encoder vibration</b>	
Checking method and corrective action	Check if the motor vibration range exceeds the specification of 2.5 G. If the vibration is within the range but the alarm still occurs, send your servo motor back to the distributor or contact Delta.
How to clear the alarm?	DI.ARST or cycle power on the servo drive.
<b>AL033 26-pin connector for the position signal converter box is disconnected or motor is abnormal</b>	
Trigger condition and cause	<p>Condition: 26-pin connector for the position signal converter box is disconnected or motor is abnormal.</p> <p>Cause:</p> <ol style="list-style-type: none"> <li>1. The 26-pin connector for the position signal converter box is wired incorrectly or disconnected.</li> <li>2. The motor is abnormal.</li> </ol>
Checking method and corrective action	<ol style="list-style-type: none"> <li>1. If the status of the position signal converter box is in Switch Mode:               <ol style="list-style-type: none"> <li>(a) When the switch is located at X1 (A, B Pulse), check if Pin 1 - 6 of the 26-pin connector for the converter box is disconnected.</li> <li>(b) When the switch is located at X2 (A-Sin B-Cos), check if Pin 8 - 13 of the 26-pin connector for the converter box is disconnected.</li> </ol> </li> <li>2. If the status of the position signal converter box is in Drive Mode:               <ol style="list-style-type: none"> <li>(a) When PM.003.X is set to 0, check if Pin 1 - 6 of the 26-pin connector for the converter box is disconnected.</li> <li>(b) When PM.003.X is set to 1, check if Pin 8 - 13 of the 26-pin connector for the converter box is disconnected.</li> </ol> </li> <li>3. If not using the position signal converter box, check for the following items.               <ol style="list-style-type: none"> <li>(a) Check if the encoder 5V power is lower than 4.3V.</li> <li>(b) Check if the cable complies with the specifications. Do not use cables exceeding the specified length or without wire mesh.</li> <li>(c) Check if the connection for the encoder signal cable is normal. Make sure the encoder signal cable is separated from the power supply or any high-current cables to avoid interference.</li> </ol> <p>If the issue persists, send your servo motor back to the distributor or contact Delta.</p> </li> </ol>
How to clear the alarm?	Cycle power on the servo drive.



AL034 Encoder internal communication error	
Trigger condition and cause	<p>Condition:</p> <ol style="list-style-type: none"> <li>Internal communication error for the absolute encoder.</li> <li>Internal error for other types of encoder.</li> </ol> <p>Cause: encoder internal communication error.</p>
Checking method and corrective action	<ol style="list-style-type: none"> <li>Check if the battery wiring is correct or loose. If it is loose, wire it again and cycle power on the system.</li> <li>Check if the battery voltage is within the normal range.</li> <li>Internal communication error for the absolute encoder occurs. Replace the motor.</li> </ol>
How to clear the alarm?	Cycle power on the servo drive.

AL035 Temperature of the encoder or external sensor exceeds the protective range	
Trigger condition and cause	<p>Condition: the temperature of the encoder connected through CN2 is over the upper limit of 100°C (212°F) or the temperature detected by the sensor connected through CN5 exceeds the protective range set by PM.022 and PM.024.</p> <p>Cause: a temperature rise is detected in the encoder connected to CN2 or in the temperature sensor connected to CN5.</p>
Checking method and corrective action	<ol style="list-style-type: none"> <li>Check the encoder temperature (CN2): Set P0.002 to -124 to read the temperature and check if it is below 100°C. If the encoder temperature is higher than 100°C, improve the heat dissipation to lower the temperature. If the temperature difference between the encoder and motor is over 30°C (86°F), send the servo motor back to Delta.</li> <li>Check the temperature sensor (CN5):                     <ol style="list-style-type: none"> <li>If not using the temperature sensor, set PM.022 to 0.</li> <li>When PM.022 = 1, set P0.002 to -145 to read the temperature and check if it is below 100°C. If the temperature of the sensor is higher than 100°C, improve the heat dissipation to lower the temperature. If the temperature difference between the temperature sensor and motor is over 30°C, send the servo motor back to Delta.</li> <li>When PM.022 = 2 or 3, check if the setting of PM.024 is correct and the temperature sensor works normally. If so, improve the heat dissipation to lower the temperature.</li> </ol> </li> </ol>
How to clear the alarm?	After the temperature becomes lower than 100°C, cycle power on the servo drive.

<b>AL036 Encoder alarm status error</b>	
Trigger condition and cause	<p>Condition: abnormal state occurred in the encoder.</p> <p>Cause: the encoder sends out an alarm signal, but the alarm status of the encoder read by the servo drive shows no error.</p>
Checking method and corrective action	<ol style="list-style-type: none"> <li>1. Check if the motor is properly grounded. Make sure the ground end (green) of the power cable is grounded to the servo drive heat sink.</li> <li>2. Check if the connection for the encoder signal cable is normal. Make sure the encoder signal cable is separated from the power supply or any high-current cables to avoid interference.</li> <li>3. Use shielded cable for the encoder cable. Pull out the wire mesh and have it correctly grounded.</li> <li>4. Check the motor speed and make sure it is within the rated range.</li> </ol> <p>If the issue persists, send your servo motor back to the distributor or contact Delta.</p>
How to clear the alarm?	DI.ARST or cycle power on the servo drive.

<b>AL040 Excessive position error of full-closed loop control</b>	
Trigger condition and cause	<p>Condition: excessive position error of full-closed loop control.</p> <p>Cause:</p> <ol style="list-style-type: none"> <li>1. The setting value of P1.073 is too low.</li> <li>2. The encoder connector may be loose or there is a problem with the connection between the motor and the mechanical parts.</li> <li>3. The input value for P1.072 can only be an integer. However, when the motor runs a cycle, if the number of A/B pulses in a full-closed loop is not an integer, the position error between the motor encoder and the auxiliary encoder accumulates. Thus, you need to set P1.085 to avoid triggering AL040.</li> </ol>
Checking method and corrective action	<ol style="list-style-type: none"> <li>1. Check the value for P1.073. If the value is too low, set a higher value.</li> <li>2. Make sure the encoder connector is firmly connected or there is no problem with the connection between the motor and the mechanical parts.</li> <li>3. Check if the value of P1.085 is set properly.</li> </ol>
How to clear the alarm?	DI.ARST

14

<b>AL041 CN5 is disconnected</b>	
Trigger condition and cause	The communication of CN5 is disconnected.
Checking method and corrective action	<ol style="list-style-type: none"> <li>1. Check the communication circuit of CN5.</li> <li>2. When CN5 is not in use, check if both P1.074.X and PM.003.U are set to 0.</li> </ol>
How to clear the alarm?	Cycle power on the servo drive.

<b>AL042 Voltage input for analog Speed command is too high</b>	
Trigger condition and cause	Voltage input for the analog Speed command is higher than the level specified by P1.083.
Checking method and corrective action	Check and make sure the voltage source for the analog Speed command is correct. Check the value of P1.083, and if this function is not required, set it to 0.
How to clear the alarm?	DI.ARST

<b>AL044 Servo function operational warning</b>	
Trigger condition and cause	<p>Condition: too many motor control functions on the servo drive are enabled.</p> <p>Cause: servo function operational alarm.</p>
Checking method and corrective action	<ol style="list-style-type: none"> <li>1. If using a filter, see if using this filter is necessary.</li> <li>2. Set P2.066 [Bit 4] to 1 to disable this alarm.</li> </ol>
How to clear the alarm?	<ol style="list-style-type: none"> <li>1. Disable the unnecessary filter, such as the low-pass filter (P1.006 - P1.008), moving filter (P1.068), low-frequency vibration suppression (P1.025 - P1.028), vibration elimination (P1.089 - P1.094), Notch filter (1<sup>st</sup> to 5<sup>th</sup> sets), percentage of friction compensation (P1.062), and motor hard stop (torque percentage) (P1.057).</li> <li>2. Set P2.066 [Bit 4] to 1 and cycle power on the servo drive.</li> </ol>

<b>AL045 E-Gear ratio value error</b>	
Trigger condition and cause	<p>Condition: when the value of the E-Gear ratio exceeds the range (1 - 262144), this alarm occurs once power is cycled to the servo drive.</p> <p>Cause: E-Gear ratio value is found to be in error after the servo drive is powered on.</p>
Checking method and corrective action	Check if the value of the E-Gear ratio is within the allowable range (1 - 262144). If not, correct the value and then cycle power on the servo drive.
How to clear the alarm?	Cycle power on the servo drive after the value is corrected.

<b>AL048 OA and OB output error</b>	
Trigger condition and cause	<p>Condition: the output frequency of the OA and OB pulses is higher than the maximum output frequency of the hardware.</p> <p>Cause:</p> <ol style="list-style-type: none"> <li>1. The resolution of the OA and OB pulses is set too high.</li> <li>2. There is interference or cable damage causing communication error.</li> <li>3. Encoder error.</li> </ol>
Checking method and corrective action	<ol style="list-style-type: none"> <li>1. The settings of P1.076 and P1.046 should follow these requirements:  <math display="block">P1.076 &gt; \text{motor speed and } \frac{\text{Motor speed}}{60} \times P1.046 \times 4 &lt; 19.8 \times 10^6</math> </li> <li>2. Check the communication error rate by setting P0.002 to -80. If this value increases continuously, it means there is interference. Check the following items: <ol style="list-style-type: none"> <li>(a) Check if the motor is properly grounded. Make sure the ground end (green) of the power cable is grounded to the servo drive heat sink.</li> <li>(b) Check if the connection for the encoder signal cable is normal. Make sure the encoder signal cable is separated from the power supply or any high-current cables to avoid interference.</li> <li>(c) Use shielded cable for the encoder cable. Pull out the wire mesh and have it correctly grounded.</li> </ol> </li> <li>3. Check the fault record (P4.000 - P4.004) and see if an alarm has occurred (AL011, AL024, AL025, or AL026). Use the checking methods and corrective actions to clear the alarm if any of them occurs.</li> <li>4. If you do not need to use the OA and OB pulses, set P2.065 [Bit 13] to 1 to disable the detection function for OA and OB output error (AL018 / AL048).</li> </ol>
How to clear the alarm?	<ol style="list-style-type: none"> <li>1. DI.ARST</li> <li>2. Contact the distributor.</li> </ol>

<b>AL050 Motor parameter identification is complete</b>	
Trigger condition and cause	Used the Motor Parameter Identification Wizard and the identification is complete.
Checking method and corrective action	Cycle power on the servo drive.
How to clear the alarm?	Cycle power on the servo drive.

AL051 Motor parameter automatic identification error	
Trigger condition and cause	<p>Condition: an error occurs when the Motor Parameter Identification Wizard function is used.</p> <p>Cause: when the motor is executing the Motor Parameter Identification Wizard function, this alarm is triggered if the friction is too large causing the motor unable to run, or the resolution, magnetic pole, or magnetic pole pitch is in error.</p>
Checking method and corrective action	<ol style="list-style-type: none"> <li>1. Check if PM.003, PM.004, and PM.045 are set correctly according to the specifications.</li> <li>2. Make sure the motor can operate properly.</li> <li>3. Check if the friction between the motor and mechanical part is too large.</li> <li>4. Check if the feedback signal is abnormal. Use the software scope and select "Feedback Position [PUU]" as the input signal for the channel to monitor whether the feedback value is correct.</li> <li>5. Check for interference causing pulse leakage.</li> <li>6. If there is interference, check the following items:                         <ol style="list-style-type: none"> <li>(a) Check if the motor is properly grounded. Make sure the ground end (green) of the power cable is grounded to the servo drive heat sink.</li> <li>(b) Use shielded cable for the feedback signal cable. Make sure the signal cable is separated from the power supply or any high-current cables to avoid interference.</li> </ol> </li> </ol>
How to clear the alarm?	DI.ARST

AL052 Initial magnetic field detection error	
Trigger condition and cause	<p>Condition:</p> <ol style="list-style-type: none"> <li>1. The initial magnetic field detection is not complete because the motor moves by more than 1/3 pole pair distance or pole pitch during the detection.</li> <li>2. When the servo is on, the servo automatically detects the magnetic field. If the detection is not complete in 4 seconds, this alarm is triggered.</li> <li>3. The motor has not released the brakes or is running unevenly, or the set screw are not removed from the mechanical parts, causing the machine unable to operate.</li> </ol> <p>Cause: when you choose not to install the Hall sensor (set PM.003.Y to 0 for not using the Hall sensor), the servo automatically detects the magnetic field when Servo On. This alarm is displayed when the servo cannot detect the magnetic field.</p>

<b>AL052 Initial magnetic field detection error</b>	
Checking method and corrective action	<ol style="list-style-type: none"> <li>1. To make sure that the source of the feedback signal is correct, check the PM.003.U setting in the Motor Parameter Identification Wizard.</li> <li>2. Check if the feedback signal is abnormal. Use the software scope and select "Feedback Position [PUU]" as the input signal for the channel to monitor whether the feedback value is correct.</li> <li>3. Make sure the motor and mechanical part can operate properly.</li> <li>4. Check if the friction between the motor and mechanical part is too large. If so, increase the set value of PM.011 by 50% at a time for testing.</li> <li>5. Check if the moving distance is too large during the initial magnetic field detection when the motor is powered on. Use the software scope and select "Feedback Position [PUU]" as the input signal for the channel to monitor whether the feedback value is correct. Try reducing the set value of PM.011 Initial magnetic field current detection.</li> <li>6. If there is interference, check the following items:                         <ol style="list-style-type: none"> <li>(a) Check if the motor is properly grounded. Make sure the ground end (green) of the power cable is grounded to the servo drive heat sink.</li> <li>(b) Use shielded cable for the feedback signal cable. Make sure the signal cable is separated from the power supply or any high-current cables to avoid interference.</li> </ol> </li> </ol>
How to clear the alarm?	DI.ARST

<b>AL053 Motor parameters are not confirmed</b>	
Trigger condition and cause	<p>Condition: if the Motor Parameter Identification Wizard function has not been executed or the identification failed, once the servo is on, this alarm is triggered.</p> <p>Cause: the Motor Parameter Identification Wizard function has not been executed for the motor or the identification process failed.</p>
Checking method and corrective action	Execute or re-execute the Motor Parameter Identification Wizard function.
How to clear the alarm?	Switch the servo to the Servo Off state to clear this alarm.

<b>AL054 Parameter is out of range due to switching of motor types</b>	
Trigger condition and cause	Condition: set value of PM.004 exceeds the allowable range. Cause: set value of PM.004 exceeds the allowable range.
Checking method and corrective action	<ol style="list-style-type: none"> <li>1. Check if the set values of PM.000, PM.003, PM.004, and PM.013 match the specifications of the connected motor.</li> <li>2. If the issue persists, set P2.008 to 18 to reset the PM parameters and cycle power on the servo drive.</li> </ol>
How to clear the alarm?	Cycle power on the servo drive.

<b>AL055 Motor magnetic field error</b>	
Trigger condition and cause	<p>Condition:</p> <ol style="list-style-type: none"> <li>1. The difference between the monitored magnetic field returned by the Hall sensor and the magnetic field calculated by the servo is too big.</li> <li>2. The detection occurs only when the linear motor speed is lower than 100 mm/s or the rotary motor speed is lower than 100 rpm.</li> </ol> <p>Cause: when PM.009 [Bit 4] is set to 1, the servo detects the current magnetic field position of the motor and compares it with the magnetic field position of the Hall sensor. When the error between the two is too large, this alarm is triggered.</p>
Checking method and corrective action	<ol style="list-style-type: none"> <li>1. Check if the Hall sensor is abnormal or there is interference.</li> <li>2. Check if the feedback signal is abnormal. Use the software scope and select "Feedback Position [PUU]" as the input signal for the channel to monitor whether the feedback value is correct.</li> <li>3. Check if the feedback signal has interference causing pulse leakage.</li> <li>4. If the encoder feedback type is a square-wave digital signal, check the following items:             <ol style="list-style-type: none"> <li>(a) Check if the motor speed is too fast and exceeds the maximum limit of 16 MHz that the hardware can receive (the limit is 4 times the frequency).</li> <li>(b) Check if the filter setting of P1.074.U is set properly.</li> </ol> </li> </ol>
How to clear the alarm?	Cycle power on the servo drive.

<b>AL056 Excessive motor speed</b>	
Trigger condition and cause	<p>Condition: when the filtered motor speed exceeds the setting of P1.111, the servo drive immediately switches to the Servo Off state and displays this alarm.</p> <p>Cause: this alarm is to remind the user that the motor speed has reached the upper limit of the current setting (P1.111).</p>
Checking method and corrective action	<ol style="list-style-type: none"> <li>1. Check the reason for the high motor speed, such as the set value of P1.111 is too small, the bandwidth is not set properly, or the linear motor parameter setting does not match the linear motor specification.</li> <li>2. Evaluate the motor speed and the condition of the mechanical parts. If allowable, increase the speed and the set value of P1.111.</li> </ol>
How to clear the alarm?	DI.ARST
<b>AL057 Feedback pulse is lost</b>	
Trigger condition and cause	<p>Condition: when P2.081 is set to 1, the servo drive will detect if there is pulse leakage. When the pulse leakage exceeds the set value of P2.082, this alarm is triggered.</p> <p>Cause:</p> <ol style="list-style-type: none"> <li>1. Pulse leakage occurs during motor operation.</li> <li>2. The pulse signal is interfered by noise.</li> </ol>
Checking method and corrective action	<ol style="list-style-type: none"> <li>1. Check if pulse leakage has occurred to the motor encoder feedback due to noise interference.</li> <li>2. If there is interference, check the following items: <ol style="list-style-type: none"> <li>(a) Check if the motor is properly grounded. Make sure the ground end (green) of the power cable is grounded to the servo drive heat sink.</li> <li>(b) Use shielded cable for the feedback signal cable. Make sure the signal cable is separated from the power supply or any high-current cables to avoid interference.</li> </ol> </li> <li>3. If the encoder feedback type is a square-wave digital signal, check if the motor speed is too fast and exceeds the maximum limit of 16 MHz that the hardware can receive (the limit is 4 times the frequency).</li> <li>4. In addition to eliminating the noise interference, if the encoder type is a square-wave digital signal, you can also filter the noise by setting the applicable filter functions. When the main encoder signal source is CN2 (PM.003.U = 0), set PM.003.Z. When the main encoder signal source is CN5 (PM.003.U = 1), set P1.074.U.</li> <li>5. Set the maximum speed limit of the motor with P1.055.</li> <li>6. Check if P2.083 is set correctly.</li> </ol>
How to clear the alarm?	Cycle power on the servo drive.



AL058 Excessive position deviation after initial magnetic field detection is complete	
Trigger condition and cause	<p>Condition:</p> <ol style="list-style-type: none"> <li>After the initial magnetic field detection is complete, the servo system then attempts, but fails to reduce the existing position error.</li> <li>If the controller issues commands when the servo system is not fully settled, the position error might thus be greater and cannot be reduced.</li> </ol> <p>Cause: the controller issues commands during initial magnetic field detection.</p>
Checking method and corrective action	<ol style="list-style-type: none"> <li>Check if the controller has issued a command immediately when it is powered on. Use the software scope and select "Command Position [PUU]" as the input signal for the channel to monitor whether there is a command issued. If so, increase the delay time for the controller to issue the command after it is powered on.</li> <li>If the controller time sequence cannot be modified due to surge interference or other factors when the power is on, set P2.088 [Bit 4] to 1 to prohibit the servo from receiving controller commands during the initial magnetic field detection.</li> </ol>
How to clear the alarm?	DI.ARST

AL05B Motor type setting does not match	
Trigger condition and cause	<p>Condition: incorrect setting of PM.000.</p> <p>Cause:</p> <ol style="list-style-type: none"> <li>A Delta motor is connected to CN2 as the main encoder, but PM.000 is not set to 0.</li> <li>A Delta motor with magnetic encoder is used, but PM.000 or PM.003 is set incorrectly.</li> </ol>
Checking method and corrective action	<ol style="list-style-type: none"> <li>Check the setting of PM.000.</li> <li>Make sure the type of motor used complies with the setting of PM.000.</li> <li>If a Delta motor with magnetic encoder is used, set PM.000 to 0 and PM.003 to 0x1XX2.</li> </ol>
How to clear the alarm?	Cycle power on the servo drive.

<b>AL05C Motor position feedback error</b>	
Trigger condition and cause	<p>Condition: sudden jumps occur to the motor position feedback.</p> <p>Cause:</p> <ol style="list-style-type: none"> <li>1. Encoder feedback is abnormal or the encoder is damaged.</li> <li>2. Encoder feedback is interfered.</li> </ol>
Checking method and corrective action	<ol style="list-style-type: none"> <li>1. Check if the feedback signal is abnormal. Use the software scope and select "Feedback Position [PUU]" as the input signal for the channel and sample at 16 kHz or 20 kHz, and then operate the motor manually to monitor whether the feedback value has discontinuous sudden jumps.</li> <li>2. Check if the feedback signal is interfered, causing sudden jumps to the motor position feedback.</li> <li>3. If the source of the main encoder is CN2, check if the communication error rate is increased due to interference. For example, check the communication error rate by setting P0.017 to -80 and monitor whether the value of P0.009 is not 0 and continuously increases.</li> </ol>
How to clear the alarm?	Cycle power on the servo drive.

<b>AL05D Detection error for offset between absolute encoder zero point and motor magnetic field zero point (PM.010)</b>	
Trigger condition and cause	<p>Condition: when the Motor Parameter Identification Wizard is executed for the third-party absolute motor, an error occurred when the Wizard detected the offset between the absolute encoder zero point and motor magnetic field zero point (PM.010).</p> <p>Cause: the difference between the actual magnetic field angle of the motor and the set value is too big.</p>
Checking method and corrective action	<ol style="list-style-type: none"> <li>1. Check if PM.003, PM.004, PM.028, and PM.045 are set correctly according to the specifications.</li> <li>2. Make sure you can manually operate the motor.</li> <li>3. Check if the friction between the motor and mechanical part is too large.</li> <li>4. Check if the feedback signal is abnormal. Use the software scope and select "Feedback Position [PUU]" as the input signal for the channel to monitor whether the feedback value is correct.</li> <li>5. If there is interference, check the following items:             <ol style="list-style-type: none"> <li>(a) Check if the motor is properly grounded. Make sure the ground end (green) of the power cable is grounded to the servo drive heat sink.</li> <li>(b) Use shielded cable for the feedback signal cable. Make sure the signal cable is separated from the power supply or any high-current cables to avoid interference.</li> </ol> </li> </ol>
How to clear the alarm?	DI.ARST

14

AL05E Position signal converter box communication failure	
Trigger condition and cause	<p>Condition: communication error occurs when the Delta position signal converter box is connected to the CN2 connector.</p> <p>Cause:</p> <ol style="list-style-type: none"> <li>1. A communication error occurred to the position signal converter box.</li> <li>2. A communication error occurred during the Motor Parameter Identification Wizard setting process.</li> </ol>
Checking method and corrective action	<ol style="list-style-type: none"> <li>1. Check the wiring of the position signal converter box.</li> <li>2. Check for the encoder cable and connector which connect the motor and CN2 of the servo drive to see if there is any poor wiring or damaged wires. If so, replace the connector and cable.</li> <li>3. Check the communication error rate by setting P0.002 to -80. If this value increases continuously, it means there is interference. Check the following items:                     <ol style="list-style-type: none"> <li>(a) Check if the motor is properly grounded. Make sure the ground end (green) of the power cable is grounded to the servo drive heat sink.</li> <li>(b) Check if the connection for the encoder signal cable is normal. Make sure the encoder signal cable is separated from the power supply or any high-current cables to avoid interference.</li> <li>(c) Use shielded cable for the encoder cable. Pull out the wire mesh and have it correctly grounded.</li> </ol> </li> </ol> <p>If you took all corrective actions but the issue persists, replace the motor.</p>
How to clear the alarm?	<p>Cycle power on the servo drive.</p>

AL060 Absolute position is lost	
Trigger condition and cause	<p>Condition: losing the recorded number of revolutions because of low battery voltage or loss of power.</p> <p>Cause:</p> <ol style="list-style-type: none"> <li>1. Voltage level of the battery is too low.</li> <li>2. The battery is replaced when the main power of the servo drive is off.</li> <li>3. The battery is not installed when the absolute function is enabled.</li> <li>4. Poor connection or disconnection of the battery power circuit.</li> </ol>

<b>AL060 Absolute position is lost</b>	
Checking method and corrective action	<ol style="list-style-type: none"> <li>1. Check if the battery voltage is below 2.9V. Re-establish the absolute origin position after replacing the battery.</li> <li>2. Do not replace or remove the battery when the servo drive's main power is off.</li> <li>3. Follow these instructions:               <ol style="list-style-type: none"> <li>(a) Install the battery.</li> <li>(b) Check the wiring between the battery box and the servo drive.</li> <li>(c) Check the encoder wiring.</li> </ol> </li> <li>4. Ensure the wiring is correct so that the battery power is supplied to the encoder and then re-establish the absolute origin position.</li> </ol>
How to clear the alarm?	Connect or reconnect the wiring so that the battery power is supplied to the encoder and then re-establish the absolute origin position. Refer to Chapter 10 for more information on the absolute servo system.

<b>AL061 Encoder undervoltage</b>	
Trigger condition and cause	<p>Condition: voltage level of the absolute encoder battery is lower than the rated value (3.1V).</p> <p>Cause: voltage level of the battery is too low.</p>
Checking method and corrective action	<ol style="list-style-type: none"> <li>1. Read the battery voltage with monitoring variable 26h to see if it is below 3.1V.</li> <li>2. Measure the battery voltage to see if it is below 3.1V.</li> </ol> <p>If the voltage is too low, replace the battery when the servo drive's main power is On.</p>
How to clear the alarm?	The alarm is cleared automatically when the voltage level is higher than 3.1V.

<b>AL062 Number of revolutions of the absolute encoder overflows (issued by encoder)</b>	
Trigger condition and cause	<p>Condition: the number of revolutions of the absolute motor exceeds the range of -32768 to +32767.</p> <p>Cause: motor's rotation cycle exceeds the allowable range.</p>
Checking method and corrective action	Check if the number of revolutions of the motor during operation is within the range of -32768 to +32767. If not, re-establish the absolute origin position.
How to clear the alarm?	Cycle power on the servo drive.

<b>AL063 Linear scale signal error</b>	
Trigger condition and cause	An error occurred to the linear scale original signal.
Checking method and corrective action	<p>Check if the linear scale and read head are installed correctly, and then set DI.ARST to On or cycle power on the servo drive.</p> <p>If the issue persists, send your servo motor back to the distributor or contact Delta.</p>

**AL063 Linear scale signal error**

How to clear the alarm?	DI.ARST or cycle power on the servo drive.
-------------------------	--

**AL064 Encoder vibration warning**

Trigger condition and cause	Condition: abnormal vibration occurred in the encoder. Cause: the internal signal or mechanical part of the encoder is abnormal, so the encoder returns a warning signal.
Checking method and corrective action	Check if the motor vibration range is within the warning range (2.0 to 2.5 G). If the vibration is below the warning range but the alarm still occurs, send your servo motor back to the distributor or contact Delta.
How to clear the alarm?	DI.ARST or cycle power on the servo drive.

**AL066 Number of revolutions of the absolute encoder overflows (issued by servo drive)**

Trigger condition and cause	Condition: the number of revolutions of the absolute motor (P0.051) exceeds half the number of revolutions of the encoder resolution.  1. The number of revolutions of a Delta motor is -32768 to +32767. 2. For third-party motors, calculate the number of revolutions based on the motor specifications.  Cause: motor's rotation cycle exceeds the allowable range.
Checking method and corrective action	1. Check if the motor's number of revolutions during operation is within the specified range. If not, re-establish the absolute origin position. 2. Make sure you have enabled the function for preventing rotary axis position loss when an overflow occurs. If it is disabled, set P2.069.Z to 1 to enable the function.
How to clear the alarm?	Re-establish the absolute origin position.

**AL067 Encoder temperature warning**

Trigger condition and cause	Condition: the encoder temperature is over the warning level of 85°C (185°F), but still under 100°C (212°F), which is within the protective range.  Cause: encoder temperature warning (85°C to 100°C).
Checking method and corrective action	Set P0.002 to -124 to read the encoder temperature and check if it matches the motor temperature. If the temperature is too high, improve the heat dissipation or decrease the operating temperature. If the temperature difference between the encoder and motor is over 30°C (86°F), send the servo motor back to Delta.
How to clear the alarm?	Cycle power on the servo drive.

<b>AL068 Absolute data transmitted by I/O is in error</b>	
Trigger condition and cause	<p>Condition: the time sequence is wrong when the absolute position is read by DI/O.</p> <p>Cause:</p> <ol style="list-style-type: none"> <li>1. Time sequence is wrong.</li> <li>2. Reading timeout.</li> </ol>
Checking method and corrective action	<ol style="list-style-type: none"> <li>1. Correct the time sequence for reading the data with DI/O:               <ol style="list-style-type: none"> <li>(a) DI.ABSQ switches to off after DO.ABSR is off.</li> <li>(b) DI.ABSQ switches to on after DO.ABSR is on.</li> </ol> </li> <li>2. Check the duration from when DO.ABSR switches on to the time when DI.ABSQ switches on and see if this duration is over 200 ms. The correct procedure should be: when DO.ABSR switches on and after the bit data of absolute position is ready, read DO.ABSD within 200 ms, switch DI.ABSQ on, and then inform the servo drive that data reading is complete.</li> </ol>
How to clear the alarm?	Cycle power on the servo drive.

<b>AL069 Wrong motor type</b>	
Trigger condition and cause	Incremental motor does not support the absolute function.
Checking method and corrective action	<ol style="list-style-type: none"> <li>1. Check whether your servo motor has an incremental or absolute encoder.</li> <li>2. Check the setting of P2.069 and correctly set the value. Set P2.069.X to 0 if desiring to operate the absolute motor as an incremental motor.</li> </ol>
How to clear the alarm?	Set P2.069.X to 0 and then cycle power on the servo drive.

AL06A Absolute position is lost	
Trigger condition and cause	<p>There are two conditions that may cause the loss of absolute position. In the first condition, the absolute position is not established. Thus, the origin is lost. In the other condition, an error occurred. After the absolute origin position is established, AL06A still occurs after power cycling of the servo drive.</p> <ul style="list-style-type: none"> <li>■ The absolute position is not established.</li> </ul> <p>Condition:</p> <ol style="list-style-type: none"> <li>1. The servo drive is used for the first time.</li> <li>2. The battery is drained and the power supply of the servo drive is cut off.</li> <li>3. When the bus communication type (CANopen, DMCNET, EtherCAT) servo is used with an absolute motor, the user issues an absolute position command after the first use or modification of the E-Gear ratio.</li> </ol> <p>Cause:</p> <ol style="list-style-type: none"> <li>1. The servo drive is used for the first time, so the absolute origin position is not established.</li> <li>2. Retaining the absolute position requires power supply, so when the battery is drained and the power supply of the servo drive is cut off, the absolute position of the servo is lost.</li> <li>3. After the E-Gear ratio is modified, the communication type position system needs to be re-established.</li> </ol> <ul style="list-style-type: none"> <li>■ An error occurred.</li> </ul> <p>Condition:</p> <ol style="list-style-type: none"> <li>1. The encoder cable is damaged, including the exterior and internal wiring.</li> <li>2. There is a momentary power failure in the battery power supply.</li> <li>3. The absolute motor is in error.</li> <li>4. The battery box is used, and J1 and J2 are connected reversely.</li> <li>5. The voltage level of the battery is lower than 2.9V.</li> </ol> <p>Cause:</p> <ol style="list-style-type: none"> <li>1. Power supply is unstable due to damage of the encoder cable.</li> <li>2. The reason for the momentary power failure may be that the battery box connector is loose or excessive machine vibration.</li> <li>3. The absolute encoder of this motor is in error.</li> <li>4. If J1 and J2 are connected reversely, the battery cannot charge the capacitor. The capacitor functions as a buffer to supply power when the power supply of the servo drive power is switched to the battery due to a main power failure.</li> </ol>

<b>AL06A Absolute position is lost</b>	
Checking method and corrective action	<ol style="list-style-type: none"> <li>1. Check if the absolute origin position is established (refer to Section 10.3.1 for more information).</li> <li>2. Avoid replacing the battery when the servo drive is powered off. It is suggested that you replace the battery when the servo drive is powered on, so the absolute encoder has continuous power supply.</li> <li>3. Re-establish the absolute origin position.</li> <li>4. Replace the encoder cable. Use the X-ray to check if the internal wiring is damaged.</li> <li>5. Check if the wiring is loose. If the wiring is fine, replace the battery box for cross-testing.</li> <li>6. Replace the servo motor.</li> <li>7. Ensure J1 is connected to the battery and J2 is connected to the servo drive.</li> </ol>
How to clear the alarm?	This alarm is automatically cleared after you establish the absolute origin position.

<b>AL06B The error between the servo drive internal position and the encoder position is too large</b>	
Trigger condition and cause	<p>Condition: when the absolute motor is powered by the battery, the number of motor rotations exceeds half the number of revolutions of the encoder resolution.</p> <p>Cause: the error between the servo drive internal position and the encoder position is too large.</p>
Checking method and corrective action	The mechanical parts are not properly fastened when the machine is being transported causing rotation of the motor.
How to clear the alarm?	Re-establish the absolute origin position.

<b>AL06E Encoder type is unidentifiable</b>	
Trigger condition and cause	The servo drive cannot identify the encoder type.
Checking method and corrective action	N/A
How to clear the alarm?	Replace the motor immediately.

<b>AL06F The absolute position is not established</b>	
Trigger condition and cause	<p>Condition: the establishment of the absolute position has timed out.</p> <p>Cause: the process for establishing the absolute position of the servo drive is in error.</p>
Checking method and corrective action	If the issue persists after you cycle power on the servo drive and re-establish the absolute origin position, contact your local distributor or technician.



<b>AL06F The absolute position is not established</b>	
How to clear the alarm?	Cycle power on the servo drive and re-establish the absolute origin position.

<b>AL070 Encoder did not complete the read / write procedure</b>	
Trigger condition and cause	Reading and writing commands are not complete.
Checking method and corrective action	Check if the wiring is correct and firmly connected. If not, correctly connect the wire again. Contact Delta if this error persists.
How to clear the alarm?	Cycle power on the servo drive.

<b>AL071 Number of revolutions of the encoder is in error</b>	
Trigger condition and cause	Condition: the number of revolutions of the encoder is in error. Cause: the internal signal of the encoder is abnormal causing error in the number of revolutions of the encoder.
Checking method and corrective action	If you executed DI.ARST but the issue persists, send your servo motor back to the distributor or contact Delta.
How to clear the alarm?	DI.ARST

<b>AL072 Encoder overspeed</b>	
Trigger condition and cause	<ol style="list-style-type: none"> <li>1. When the encoder is powered by the servo drive: over 8,800 rpm.</li> <li>2. When the encoder is powered by the battery: over 10,000 rpm.</li> <li>3. Voltage level of the battery is too low.</li> </ol>
Checking method and corrective action	<ol style="list-style-type: none"> <li>1. Check if the motor is properly grounded. Make sure the ground end (green) of the power cable is grounded to the servo drive heat sink.</li> <li>2. Check if the connection for the encoder signal cable is normal. Make sure the encoder signal cable is separated from the power supply or any high-current cables to avoid interference.</li> <li>3. Use shielded cable for the encoder cable. Pull out the wire mesh and have it correctly grounded.</li> <li>4. Check the motor speed and make sure it is within the rated range.</li> <li>5. Measure the battery voltage to see if it is below 3.1V.</li> <li>6. Check if the battery wiring has poor contact.</li> </ol> <p>If the issue persists, send your servo motor back to the distributor or contact Delta.</p>
How to clear the alarm?	Cycle power on the servo drive.

<b>AL073 Encoder memory error</b>	
Trigger condition and cause	An error occurs when the encoder is reading data from or writing data to EEPROM.
Checking method and corrective action	<ol style="list-style-type: none"> <li>1. Check if the motor is properly grounded. Make sure the ground end (green) of the power cable (green end) is grounded to the servo drive heat sink.</li> <li>2. Check if the connection for the encoder signal cable is normal. Make sure the encoder signal cable is separated from the power supply or any high-current cables to avoid interference.</li> <li>3. Use shielded cable for the encoder cable. Pull out the wire mesh and have it correctly grounded.</li> <li>4. Check the motor speed and make sure it is within the rated range.</li> </ol> <p>If the issue persists, send your servo motor back to the distributor or contact Delta.</p>
How to clear the alarm?	Cycle power on the servo drive.

<b>AL074 Encoder single-turn absolute position is in error</b>	
Trigger condition and cause	The single-turn position in the encoder is in error.
Checking method and corrective action	<ol style="list-style-type: none"> <li>1. Check if the motor is properly grounded. Make sure the ground end (green) of the power cable is grounded to the servo drive heat sink.</li> <li>2. Check if the connection for the encoder signal cable is normal. Make sure the encoder signal cable is separated from the power supply or any high-current cables to avoid interference.</li> <li>3. Use shielded cable for the encoder cable. Pull out the wire mesh and have it correctly grounded.</li> <li>4. Check the motor speed and make sure it is within the rated range.</li> </ol> <p>If the issue persists, send your servo motor back to the distributor or contact Delta.</p>
How to clear the alarm?	Cycle power on the servo drive.

<b>AL075 Encoder absolute number of revolutions is in error</b>	
Trigger condition and cause	The absolute number of revolutions in the encoder is in error.
Checking method and corrective action	<ol style="list-style-type: none"> <li>1. Check if the motor is properly grounded. Make sure the ground end (green) of the power cable is grounded to the servo drive heat sink.</li> <li>2. Check if the connection for the encoder signal cable is normal. Make sure the encoder signal cable is separated from the power supply or any high-current cables to avoid interference.</li> <li>3. Use shielded cable for the encoder cable. Pull out the wire mesh and have it correctly grounded.</li> <li>4. Check the motor speed and make sure it is within the rated range.</li> </ol> <p>If the issue persists, send your servo motor back to the distributor or contact Delta.</p>

<b>AL075 Encoder absolute number of revolutions is in error</b>	
How to clear the alarm?	Cycle power on the servo drive.
<b>AL077 Encoder internal error</b>	
Trigger condition and cause	Encoder internal error (internal computing error).
Checking method and corrective action	<ol style="list-style-type: none"> <li>1. Check if the motor is properly grounded. Make sure the ground end (green) of the power cable is grounded to the servo drive heat sink.</li> <li>2. Check if the connection for the encoder signal cable is normal. Make sure the encoder signal cable is separated from the power supply or any high-current cables to avoid interference.</li> <li>3. Use shielded cable for the encoder cable. Pull out the wire mesh and have it correctly grounded.</li> <li>4. Check the motor speed and make sure it is within the rated range.</li> </ol> <p>If the issue persists, send your servo motor back to the distributor or contact Delta.</p>
How to clear the alarm?	Cycle power on the servo drive.
<b>AL079 Encoder parameter setting incomplete</b>	
Trigger condition and cause	The servo drive is not cycled after the encoder parameter is written to the encoder, so the parameter value is not updated.
Checking method and corrective action	Check if the encoder parameter is written. If so, cycle power to activate the parameter.
How to clear the alarm?	Cycle power on the servo drive.
<b>AL07A Encoder Z phase position is lost</b>	
Trigger condition and cause	Encoder Z phase position is in error.
Checking method and corrective action	Send your servo motor back to the distributor or contact Delta.
How to clear the alarm?	N/A
<b>AL07B Encoder memory is busy</b>	
Trigger condition and cause	The encoder memory is busy.
Checking method and corrective action	<ol style="list-style-type: none"> <li>1. Check if the motor is properly grounded. Make sure the ground end (green) of the power cable is grounded to the servo drive heat sink.</li> <li>2. Check if the connection for the encoder signal cable is normal. Make sure the encoder signal cable is separated from the power supply or any high-current cables to avoid interference.</li> </ol>

<b>AL07B Encoder memory is busy</b>	
	<ol style="list-style-type: none"> <li>Use shielded cable for the encoder cable. Pull out the wire mesh and have it correctly grounded.</li> <li>Check the motor speed and make sure it is within the rated range.</li> </ol> <p>If the issue persists, send your servo motor back to the distributor or contact Delta.</p>
How to clear the alarm?	Cycle power on the servo drive.

<b>AL07C Command to clear the absolute position is issued when the motor speed is over 200 rpm</b>	
Trigger condition and cause	The command to clear the absolute position is issued when the motor speed is over 200 rpm.
Checking method and corrective action	<ol style="list-style-type: none"> <li>Check if a command to clear the absolute position is issued while the motor speed is over 200 rpm. If so, reduce the motor speed until the speed is lower than 200 rpm, and then follow the procedure for clearing the absolute position to clear this alarm.</li> <li>Do not issue a command to clear the absolute position when the motor speed is over 200 rpm.</li> </ol>
How to clear the alarm?	DI.ARST or cycle power on the servo drive.

<b>AL07D Motor stops operating when servo drive power is cycled before AL07C is cleared</b>	
Trigger condition and cause	AL07C occurs and is not cleared before power is cycled on the servo drive, causing the motor to stop operating.
Checking method and corrective action	Use DI.ARST to clear the alarm. Once this alarm is cleared, AL07C occurs. Follow the checking method and corrective action to clear AL07C.
How to clear the alarm?	DI.ARST or cycle power on the servo drive.

<b>AL07E Error occurs when the encoder clears the procedure</b>	
Trigger condition and cause	The number of retry attempts for the encoder to clear the procedure exceeds 11 times.
Checking method and corrective action	If the issue persists, set P0.002 to -80 to check the communication quality of the encoder. If the communication is normal, use DI.ARST to clear this alarm.
How to clear the alarm?	DI.ARST or cycle power on the servo drive.

<b>AL07F Encoder version error</b>	
Trigger condition and cause	The encoder version read by the servo drive is in error.
Checking method and corrective action	N/A
How to clear the alarm?	Replace the motor immediately.

<b>AL083 Servo drive outputs excessive current</b>	
Trigger condition and cause	<p>Condition: during general operation, this alarm occurs when the servo drive outputs current that is over the allowable level specified by the firmware. This alarm protects IGBT from overheating or burning because of the high current.</p> <p>Cause:</p> <ol style="list-style-type: none"> <li>1. UVW is short-circuited.</li> <li>2. Motor wiring is in error.</li> <li>3. The analog signal GND for the servo drive is interfered.</li> </ol>
Checking method and corrective action	<ol style="list-style-type: none"> <li>1. Check the the motor power cable and its connector. If metal wire is exposed or the wire is torn, the UVW can short-circuit. In this case, replace the power cable to avoid a short circuit.</li> <li>2. Refer to Chapter 3 Wiring and check the following items:               <ol style="list-style-type: none"> <li>(a) If you do not use the Delta standard power cable, make sure the UVW wiring sequence is correct.</li> <li>(b) Make sure the UVW wiring between the servo drive and motor is correctly connected.</li> </ol> </li> <li>3. Check if the analog signal GND is mistakenly connected to another ground signal (incorrect connection can cause interference). Do not use a common ground for the analog signal GND and other signal cables. Follow the wiring instructions in Chapter 3.</li> </ol>
How to clear the alarm?	DI.ARST

<b>AL085 Regeneration setting error</b>	
Trigger condition and cause	<p>Condition: regeneration control error.</p> <p>Cause: regenerative resistor is not operating, but the regenerative voltage remains at 400V for a period of time.</p>
Checking method and corrective action	<p>Check the connection for the regenerative resistor, re-calculate the value for the regenerative resistor, and correctly set the values of P1.052 and P1.053.</p> <p>If the issue persists, send your servo drive back to Delta.</p>
How to clear the alarm?	DI.ARST

<b>AL086 Regenerative resistor overload</b>	
Trigger condition and cause	<p>Condition: excessive energy in the capacitor of the servo drive is released to the regenerative resistor causing overload of the resistor.</p> <p>Cause:</p> <ol style="list-style-type: none"> <li>1. Incorrect selection of the regenerative resistor or no connection to an external regenerative resistor.</li> <li>2. Incorrect parameter settings for P1.052 and P1.053.</li> <li>3. Other energy (such as interference) is input to the servo drive or the input voltage is higher than the allowable rated voltage.</li> <li>4. Malfunction of the servo drive hardware.</li> </ol>
Checking method and corrective action	<ol style="list-style-type: none"> <li>1. Check the connection for the regenerative resistor and correctly set the values of P1.052 and P1.053.</li> <li>2. Reassess whether the regenerative energy exceeds the value of P1.053. If so, replace the regenerative resistor with a regenerative resistor that has a higher capacity.</li> <li>3. Use a voltmeter to measure if the input voltage from the power supply is within the allowable rated voltage (refer to Appendix A Specifications). If the input voltage exceeds the rated range, remove the interference source.</li> <li>4. Measure the voltage between P3 and ⊖ terminals. If it does not match the displayed DC Bus voltage when you enter the monitoring code 14 to P0.002, the servo drive may be malfunctioning. Send your servo drive back to the distributor or contact Delta.</li> <li>5. If you took the preceding actions and the issue persists, use a scope with a differential probe to measure whether the input voltage has high-frequency signal interference. If there is interference, remove the interference source, and use the right voltage source or connect the regulator in series.</li> </ol>
How to clear the alarm?	DI.ARST
<b>AL087 Hardware device error</b>	
Trigger condition and cause	Hardware device is in error.
Checking method and corrective action	Send your servo drive back to the distributor or contact Delta.
How to clear the alarm?	N/A
<b>AL088 Servo function operational alarm</b>	
Trigger condition and cause	<p>Condition: too many motor control functions on the servo drive are enabled.</p> <p>Cause: servo function operational alarm.</p>

<b>AL088 Servo function operational alarm</b>	
Checking method and corrective action	If using a filter, see if using this filter is necessary.
How to clear the alarm?	Disable the filter if it is not required, such as the low-pass filter (P1.006 - P1.008), moving filter (P1.068), low-frequency vibration suppression (P1.025 - P1.028), vibration elimination (P1.089 - P1.094), Notch filter (1 <sup>st</sup> to 5 <sup>th</sup> sets), percentage of friction compensation (P1.062), and motor hard stop - torque percentage (P1.057).

<b>AL089 Current detection interference</b>	
Trigger condition and cause	Condition: current detection interference. Cause: current detection in the servo drive is affected by an external interference source.
Checking method and corrective action	Check the environment around the servo drive to see if there is any interference source.
How to clear the alarm?	<ol style="list-style-type: none"> <li>1. Remove the interference source or move the servo drive away from the interference source.</li> <li>2. Set P2.112 [Bit 1] to 0 to disable AL089.</li> <li>3. If the issue persists, send your servo drive back to the distributor or contact Delta.</li> </ol>

<b>AL08A Auto-tuning function - command error</b>	
Trigger condition and cause	Condition: no command is issued within 15 seconds after the servo drive starts the auto-tuning procedure. Cause: <ol style="list-style-type: none"> <li>1. When the command source is the controller, neither the controller nor the position register issued the command.</li> <li>2. When the command source is the servo drive, Position 1 and Position 2 specify the same position.</li> <li>3. The signal cable is not connected or incorrectly connected so that the servo drive cannot receive the command.</li> </ol>
Checking method and corrective action	<ol style="list-style-type: none"> <li>1. Make sure a command is being issued.</li> <li>2. Set Position 1 and Position 2 again.</li> <li>3. Make sure the wiring between the controller and servo drive is correct.</li> </ol>
How to clear the alarm?	DI.ARST

<b>AL08B Auto-tuning function - dwell time is too short</b>	
Trigger condition and cause	<p>Condition: the dwell time is too short when the command source is the controller in the auto-tuning procedure. The auto-tuning algorithm requires a certain amount of time to perform the calculation. The tuning result is affected if the dwell time is too short.</p> <p>Cause: dwell time in the cycle is too short.</p>
Checking method and corrective action	<ol style="list-style-type: none"> <li>1. For a reciprocating motion between two points, a dwell is required on the return, which has to be longer than 1 second. Furthermore, the duration of a single command cannot exceed 20 seconds.</li> <li>2. For rotation in a single direction, dwell time is required when the motor rotates a certain number of cycles (&gt; 2 cycles).</li> </ol>
How to clear the alarm?	DI.ARST

<b>AL08C Auto-tuning function - inertia estimation error</b>	
Trigger condition and cause	<p>Condition: inertia estimation error occurs when the servo drive starts the auto-tuning procedure.</p> <p>Cause:</p> <ol style="list-style-type: none"> <li>1. Rotation speed is too slow.</li> <li>2. Acceleration or deceleration time is too long.</li> <li>3. Load inertia of the machine is too large.</li> <li>4. Inertia variation of the machine is too drastic.</li> </ol>
Checking method and corrective action	<ol style="list-style-type: none"> <li>1. The lowest speed should be no less than 200 rpm. It is suggested that you set the speed to 500 rpm or higher.</li> <li>2. The time for the motor to accelerate from 0 rpm to 3,000 rpm or decelerate from 3,000 rpm to 0 rpm must be within 1.5 seconds.</li> <li>3. The load inertia should be less than 50 times the motor inertia.</li> <li>4. Avoid applications that require drastic variation in the inertia.</li> </ol>
How to clear the alarm?	DI.ARST

<b>AL095 Regenerative resistor is disconnected</b>	
Trigger condition and cause	The value of P1.053 (Regenerative resistor capacity) is not 0 and the external regenerative resistor or the brake wiring is in error.
Checking method and corrective action	<ol style="list-style-type: none"> <li>1. If the servo braking requires the regenerative resistor, correctly connect the external regenerative resistor. Once you connect the resistor, make sure that the value of P1.053 is correct.</li> </ol>



<b>AL095 Regenerative resistor is disconnected</b>	
	<p>2. If not using the regenerative resistor, set P1.053 (Regenerative resistor capacity) to 0.</p> <p>If the issue persists, send your servo drive back to the distributor or contact Delta.</p>
How to clear the alarm?	DI.ARST

<b>AL099 DSP firmware error</b>	
Trigger condition and cause	EEPROM is not reset after DSP firmware is updated.
Checking method and corrective action	Check if the firmware is updated. If so, set P2.008 to 30 first and then set it to 28. Next, cycle power on the servo drive. Contact Delta if this error persists.
How to clear the alarm?	Set P2.008 to 30 and then 28. Cycle power on the servo drive.

<b>AL09C Parameter reset failed</b>	
Trigger condition and cause	<p>Condition: the parameter reset process is not complete.</p> <p>Cause: an error occurred during the parameter reset process, so the reset procedure could not be completed.</p>
Checking method and corrective action	Check if the power is cut off during the reset process. Check the power wiring and switch.
How to clear the alarm?	Set P2.008 to 30 and then 28. Cycle power on the servo drive.

<b>AL0A6 Absolute positions of the servo drive and motor do not match</b>	
Trigger condition and cause	<p>Condition: suppose there are servo drive A, servo motor A, servo drive B, and servo motor B. Servo drive A and servo drive B have established the absolute origin positions with servo motor A and servo motor B respectively. In this case, if you operate servo drive A with servo motor B, AL0A6 will be triggered.</p> <p>Cause: the servo drive or servo motor is changed.</p>
Checking method and corrective action	Re-establish the absolute origin positions.
How to clear the alarm?	Re-establish the absolute origin positions.

<b>AL111 Buffer overflow occurs when SDO is received</b>	
Trigger condition and cause	SDO Rx Buffer overflows (the servo drive receives more than two SDOs within 1 ms).
Checking method and corrective action	Check if the servo drive (master) receives or sends more than one SDO within 1 ms.
How to clear the alarm?	NMT: reset node, OD 6040h [Bit 7] (Fault reset), or DI.ARST.

<b>AL112 Buffer overflow occurs when PDO is received</b>	
Trigger condition and cause	PDO Rx Buffer overflows (the servo drive receives more than two PDOs of the same COB-ID within 1 ms).
Checking method and corrective action	Check if the servo drive (master) receives or sends more than one PDO of the same COB-ID within 1 ms.
How to clear the alarm?	NMT: reset node, OD 6040h [Bit 7] (Fault reset), or DI.ARST.

<b>AL113 TxPDO transmission failed</b>	
Trigger condition and cause	PDO packet cannot be successfully sent.
Checking method and corrective action	Check if the communication circuit of the servo drive works normally.
How to clear the alarm?	NMT: reset node, OD 6040h [Bit 7] (Fault reset), or DI.ARST.

<b>AL121 Object's index does not exist when PDO is accessed</b>	
Trigger condition and cause	When the servo drive receives the PDO from the controller, the specified object's index number is incorrect, so the servo drive cannot identify it.
Checking method and corrective action	<ol style="list-style-type: none"> <li>1. Check if the object's index number for PDO mapping of the controller is correct.</li> <li>2. If the index number is correct, it means this specified object is not supported by the servo drive. Check if it is necessary to use this object or if you can substitute it with a different object.</li> </ol>
How to clear the alarm?	NMT: reset node, OD 6040h [Bit 7] (Fault reset), or DI.ARST.

<b>AL122 Object's sub-index does not exist when PDO is accessed</b>	
Trigger condition and cause	When the servo drive receives the PDO from the controller, the specified object's sub-index number is incorrect, so the servo drive cannot identify it.
Checking method and corrective action	<ol style="list-style-type: none"> <li>1. Check if the object's sub-index number for PDO mapping of the controller is correct.</li> </ol>

<b>AL122 Object's sub-index does not exist when PDO is accessed</b>	
	2. If the sub-index number is correct, it means this specified object is not supported by the servo drive. Check if it is necessary to use this object or if you can substitute it with a different object.
How to clear the alarm?	NMT: reset node, OD 6040h [Bit 7] (Fault reset), or DI.ARST.

<b>AL123 Data length error occurs when PDO is accessed</b>	
Trigger condition and cause	Data length in the message does not match the length of the specified object.
Checking method and corrective action	Check if the data length of PDO mapping entry is changed when the servo drive receives or sends the PDO.
How to clear the alarm?	NMT: reset node, OD 6040h [Bit 7] (Fault reset), or DI.ARST.

<b>AL124 Data range error occurs when PDO is accessed</b>	
Trigger condition and cause	The data value in the message is out of range for the specified object.
Checking method and corrective action	Check if the written data is within range when the servo drive receives or sends the PDO.
How to clear the alarm?	NMT: reset node, OD 6040h [Bit 7] (Fault reset), or DI.ARST.

<b>AL125 PDO object is read-only and write-protected</b>	
Trigger condition and cause	The specified object in the message is read-only and write-protected.
Checking method and corrective action	Check if the object for PDO mapping is read-only.
How to clear the alarm?	NMT: reset node, OD 6040h [Bit 7] (Fault reset), or DI.ARST.

<b>AL126 Specified object does not support PDO mapping</b>	
Trigger condition and cause	The specified object does not support PDO mapping.
Checking method and corrective action	Check if the specified object supports PDO mapping when the servo drive receives or sends the PDO.
How to clear the alarm?	NMT: reset node, OD 6040h [Bit 7] (Fault reset), or DI.ARST.

<b>AL127 PDO object is write-protected when servo drive is on</b>	
Trigger condition and cause	PDO object is write-protected (unchangeable) when the servo drive is on.
Checking method and corrective action	Make sure no specified object is written when the servo drive receives or sends the PDO in the Servo On state.
How to clear the alarm?	NMT: reset node, OD 6040h [Bit 7] (Fault reset), or DI.ARST.

<b>AL128 Error occurs when PDO object is read from EEPROM</b>	
Trigger condition and cause	An error occurs when the default value is loaded from ROM at start-up. All objects are automatically restored to default values.
Checking method and corrective action	Check if an error occurs because the specified object is read from EEPROM when the servo drive receives or sends the PDO.
How to clear the alarm?	NMT: reset node, OD 6040h [Bit 7] (Fault reset), or DI.ARST.

<b>AL129 Error occurs when PDO object is written to EEPROM</b>	
Trigger condition and cause	An error occurs when the PDO object is written to EEPROM.
Checking method and corrective action	Check if an error occurs because the specified object is written to EEPROM when the servo drive receives or sends the PDO.
How to clear the alarm?	NMT: reset node, OD 6040h [Bit 7] (Fault reset), or DI.ARST.

<b>AL130 Accessing address of EEPROM is out of range</b>	
Trigger condition and cause	The amount of data in the ROM is greater than the allowable space specified by the firmware. It is probably because the firmware has been updated, but the data in the ROM was stored by the previous firmware version.
Checking method and corrective action	Check if the specified object causes the accessing address in EEPROM exceeds the range when the servo drive receives or sends the PDO.
How to clear the alarm?	NMT: reset node, OD 6040h [Bit 7] (Fault reset), or DI.ARST.

<b>AL131 EEPROM CRC calculation error</b>	
Trigger condition and cause	The data in ROM is damaged. All objects are automatically restored to default values.
Checking method and corrective action	Check if the specified object causes a CRC calculation error in EEPROM when the servo drive receives or sends the PDO. Usually, this alarm is caused by an error in DSP.
How to clear the alarm?	NMT: reset node, OD 6040h [Bit 7] (Fault reset), or DI.ARST.

<b>AL132 Parameter is write-protected</b>	
Trigger condition and cause	When data is written to the parameter using bus communication, the parameter is currently write-protected.
Checking method and corrective action	Refer to the corresponding parameter description to write data to the parameter.
How to clear the alarm?	NMT: reset node, OD 6040h [Bit 7] (Fault reset), or DI.ARST.

<b>AL170 Bus communication timeout</b>	
Trigger condition and cause	The servo drive does not receive any PDO data within the set communication cycle time.
Checking method and corrective action	<ol style="list-style-type: none"> <li>1. Check if the communication is normal.</li> <li>2. Check if the wiring is correctly connected.</li> </ol>
How to clear the alarm?	NMT: reset node, OD 6040h [Bit 7] (Fault reset), or DI.ARST.

<b>AL180 Bus communication timeout</b>	
Trigger condition and cause	The servo drive does not receive any PDO data within the set communication cycle time.
Checking method and corrective action	<ol style="list-style-type: none"> <li>1. Check if the communication is normal.</li> <li>2. Check if the wiring is correctly connected.</li> </ol>
How to clear the alarm?	NMT: reset node, OD 6040h [Bit 7] (Fault reset), or DI.ARST.

<b>AL185 Bus hardware error</b>	
Trigger condition and cause	Condition: bus communication is cut off. Cause: abnormal communication hardware.
Checking method and corrective action	<ol style="list-style-type: none"> <li>1. Check if the communication cable is intact and firmly connected.</li> <li>2. Check the communication quality. It is suggested that you use common grounding and shielded cable.</li> <li>3. For communication type models, check if the value of monitoring variable 120 increases continuously.</li> </ol>
How to clear the alarm?	NMT: reset node, OD 6040h [Bit 7] (Fault reset), or DI.ARST.

<b>AL186 Bus data transmission error</b>	
Trigger condition and cause	Bus data transmission error.
Checking method and corrective action	<ol style="list-style-type: none"> <li>1. Check if the communication cable is properly connected and whether there is any noise interference. Replace the communication cable or eliminate the noise if necessary.</li> </ol>

<b>AL186 Bus data transmission error</b>	
	2. There are an excessive number of slave stations and the communication cycle time is too short. Lengthen the communication cycle.
How to clear the alarm?	NMT: reset node, OD 6040h [Bit 7] (fault reset), or DI.ARST.

<b>AL201 Initialization error of object dictionary data</b>	
Trigger condition and cause	Condition: an error has occurred when the servo drive loads data from EEPROM. Cause: initialization error of CANopen data.
Checking method and corrective action	<ol style="list-style-type: none"> <li>If the alarm is cleared after power cycling of the servo drive, it means the error occurred at the moment when the servo drive reads the data.</li> <li>If the issue persists after power cycling of the servo drive, it means the data in the EEPROM is damaged and you need to write the correct values again. See the following methods: <ol style="list-style-type: none"> <li>To write the default value, set P2.008 to 30 and then 28, or use the CANopen object OD 1011h to complete the setting.</li> <li>To write the current value, set the CANopen object OD 1010h.</li> </ol> </li> <li>If you took the corrective actions but the issue persists, it means the data array is incorrect. Set P2.008 to 10 to reset the parameters.</li> </ol>
How to clear the alarm?	OD 6040h [Bit 7] (Fault reset), DI.ARST, or OD 1011h.

<b>AL203 Second development platform - task configuration number is out of range</b>	
Trigger condition and cause	Condition: task number is out of range when the task is configured. Cause: incorrect use of the command of the second development platform.
Checking method and corrective action	Refer to the command descriptions for the second development platform to ensure the correct use of the commands. If you took the corrective action but the issue persists, contact the local distributor or technician.
How to clear the alarm?	DI.ARST

<b>AL207 Parameter group of Type [8] PR is out of range</b>	
Trigger condition and cause	Condition: when Type [8] PR command specifies Parameter as the data source, the parameter group is out of range. Cause: parameter group exceeds the range.
Checking method and corrective action	Write parameter using PR procedure: when the data source is Parameter and the group setting exceeds the range, check the setting range of the group for the written parameters.
How to clear the alarm?	DI.ARST

<b>AL209 Parameter number of Type [8] PR is out of range</b>	
Trigger condition and cause	Condition: when Type [8] PR command specifies Parameter as the data source, the parameter number is out of range. Cause: parameter number exceeds the range.
Checking method and corrective action	Write parameter using PR procedure: when the data source is Parameter and the parameter number setting exceeds the range, check the setting range of the number for the written parameters.
How to clear the alarm?	DI.ARST

<b>AL211 Parameter format setting of Type [8] PR is in error</b>	
Trigger condition and cause	Condition: parameter format setting of Type [8] PR command is in error. Cause: 1. Incorrect parameter format. 2. The ASDA-Soft software version and the firmware version do not match.
Checking method and corrective action	1. Check if the parameter format is correct. 2. Check if you are using the latest version of the ASDA-Soft software. If you took the corrective actions but the issue persists, contact the local distributor or technician.
How to clear the alarm?	DI.ARST

<b>AL213 Parameter setting of Type [8] PR is in error</b>	
Trigger condition and cause	Condition: when you use Type [8] PR command to write the parameter, the parameter value is incorrect. Cause: an error occurs when you write the parameter with Type [8] PR command.
Checking method and corrective action	Make sure the parameter value is within the correct range.
How to clear the alarm?	DI.ARST

<b>AL215 Parameter written by Type [8] PR is read-only</b>	
Trigger condition and cause	Condition: the read-only parameter is written by Type [8] PR command. Cause: an error occurs when you write the parameter with Type [8] PR command.
Checking method and corrective action	The specified parameter is read-only.
How to clear the alarm?	DI.ARST

<b>AL217 Parameter written by Type [8] PR is write-protected when Servo On</b>	
Trigger condition and cause	Condition: when you use Type [8] PR command to write the parameter, the parameter is write-protected when the servo drive is On or the parameter value exceeds the range. Cause: an error occurs when you write the parameter with Type [8] PR command.
Checking method and corrective action	Write the parameter when the servo drive is Off and make sure the parameter value is within the range.
How to clear the alarm?	Modify the PR command and the parameter.

<b>AL219 Parameter written by Type [8] PR is write-protected</b>	
Trigger condition and cause	Condition: the parameter written by Type [8] PR command is write-protected. Cause: the parameter write-protected function is enabled.
Checking method and corrective action	Check if the parameter and data array protection function (P5.097) is enabled.
How to clear the alarm?	Disable the parameter and data array protection function or reset the parameters.

<b>AL21B Second development platform - memory stack is out of range</b>	
Trigger condition and cause	Condition: when a stack control command is used, the memory address is out of range. Cause: incorrect use of the command of the second development platform.
Checking method and corrective action	Refer to the command descriptions for the second development platform to ensure the correct use of the commands. If you took the corrective action but the issue persists, contact the local distributor or technician.



**AL21B Second development platform - memory stack is out of range**

How to clear the alarm?	DI.ARST
-------------------------	---------

**AL21D Second development platform - a divisor in an expression is zero in the program**

Trigger condition and cause	Condition: a divisor in an expression is zero in the program. Cause: programming error of the second development platform.
Checking method and corrective action	Check if the programs of the second development platform contain expressions with zero as the divisor. If you took the corrective action but the issue persists, contact the local distributor or technician.
How to clear the alarm?	DI.ARST

**AL221 Second development platform - a non-existing mode is used**

Trigger condition and cause	Condition: the MODE command is used to execute a non-existing mode number. Cause: incorrect use of the command of the second development platform.
Checking method and corrective action	Refer to the command descriptions for the second development platform to ensure the correct use of the commands. If you took the corrective action but the issue persists, contact the local distributor or technician.
How to clear the alarm?	DI.ARST

**AL223 Second development platform - some commands are not allowed to be used when the servo is in the ERROR or FAULT state**

Trigger condition and cause	Condition: the servo is in the ERROR or FAULT state when a specific command is used. Cause: incorrect use of the command of the second development platform.
Checking method and corrective action	Refer to the command descriptions for the second development platform to ensure if the servo can be in the ERROR or FAULT state when the command is used. If you took the corrective action but the issue persists, contact the local distributor or technician.
How to clear the alarm?	DI.ARST

**AL22D Absolute positioning cannot be executed when E-Cam is engaged**

Trigger condition and cause	Condition: absolute positioning is executed when E-Cam is engaged. Cause: absolute positioning is executed when E-Cam is engaged.
Checking method and corrective action	Check if E-Cam is engaged when the servo is executing absolute positioning.
How to clear the alarm?	DI.ARST

<b>AL231 Monitoring variable code specified byType [8] PR is out of range</b>	
Trigger condition and cause	<p>Condition: when Type [8] PR command specifies Monitoring variable as the data source, the monitoring variable code, Sys_Var, is out of range.</p> <p>Cause: the monitoring variable code is out of range.</p>
Checking method and corrective action	Write parameter using PR procedure: when the data source is Monitoring variable and the code exceeds the range, check the setting range of the code for the monitoring variable.
How to clear the alarm?	DI.ARST

<b>AL235 Position counter overflow warning</b>	
Trigger condition and cause	<p>Condition: a positioning command is executed after the overflow of the position command counter.</p> <p>Cause: overflow of the position command counter.</p>
Checking method and corrective action	<p>Incremental system:</p> <p>When the motor keeps operating in one direction, this leads to overflow of the position feedback register (FB_PUU), and the position system cannot display the correct position. Issuing an absolute position command after overflow results in this error. Use the scope to check if the feedback position has overflowed and then execute the homing procedure.</p> <p>Absolute system:</p> <p>This error occurs when the absolute positioning command is issued in the following conditions:</p> <ol style="list-style-type: none"> <li>1. Position feedback register (FB_PUU) overflows.</li> <li>2. Absolute origin position is not established after the setting of P1.001.Z is changed.</li> <li>3. Absolute origin position is not established after the E-Gear ratio (P1.044 and P1.045) is changed.</li> <li>4. The absolute origin position is established but the homing procedure is incomplete.</li> <li>5. When AL060 and AL062 occur, use the scope to check if the feedback position has overflowed. Check whether the preceding conditions have occurred, and then establish the absolute origin position.</li> </ol>
How to clear the alarm?	<p>Incremental system: perform homing procedure after using DI.ARST to clear the alarm.</p> <p>Absolute system: establish the absolute origin position.</p>

<b>AL237 Rotary axis position is undefined</b>	
Trigger condition and cause	The starting point of the rotary axis position is not defined before you operate the rotary axis position control and execute the rotary axis positioning command. This alarm occurs because the servo drive cannot identify the rotary axis position system.
Checking method and corrective action	Check if the rotary axis position is undefined: perform the homing procedure before using the rotary axis position control to avoid triggering this alarm.
How to clear the alarm?	DI.ARST

<b>AL239 Second development platform - the argument of the LOOP_CMD command is out of range</b>	
Trigger condition and cause	Condition: when the LOOP_CMD command is used, the input argument is out of range. Cause: incorrect use of the command of the second development platform.
Checking method and corrective action	Refer to the command descriptions for the second development platform to ensure the correct use of the commands. If you took the corrective action but the issue persists, contact the local distributor or technician.
How to clear the alarm?	DI.ARST

<b>AL23F Second development platform - parameter is written to a memory address that is out of range</b>	
Trigger condition and cause	Condition: when the command for writing the parameter is used, the parameter is written to a memory address that is out of range. Cause: incorrect use of the command of the second development platform.
Checking method and corrective action	Refer to the command descriptions for the second development platform to ensure the correct use of the commands. If you took the corrective action but the issue persists, contact the local distributor or technician.
How to clear the alarm?	DI.ARST

<b>AL245 PR positioning timeout</b>	
Trigger condition and cause	Condition: PR positioning function is triggered. Cause: the time for executing positioning is too long.
Checking method and corrective action	Check if the conditions for completing the PR commands are not set or not triggered causing the PR command incomplete.
How to clear the alarm?	DI.ARST or cycle power on the servo drive.

**AL247 Second development platform - the MATH\_ACC command called a math function that is out of range**

Trigger condition and cause	Condition: the function ID of the math function called by the MATH_ACC command is out of range. Cause: incorrect use of the command of the second development platform.
Checking method and corrective action	Refer to the command descriptions for the second development platform to ensure the correct use of the commands. If you took the corrective action but the issue persists, contact the local distributor or technician.
How to clear the alarm?	DI.ARST

**AL249 PR path number is out of range**

Trigger condition and cause	Condition: the number of the triggered PR path exceeds the upper limit. Cause: the number of the triggered PR path exceeds 99.
Checking method and corrective action	<ol style="list-style-type: none"> <li>1. Check if the PR command jumps to a path exceeding the range.</li> <li>2. Check if the PR command format is correct.</li> </ol>
How to clear the alarm?	DI.ARST or cycle power on the servo drive.

**AL251 Second development platform - the argument of the MATH\_POWER command is out of range**

Trigger condition and cause	Condition: when the MATH_POWER command is used, the argument is not within the range of 0 - 10. Cause: incorrect use of the command of the second development platform.
Checking method and corrective action	Refer to the command descriptions for the second development platform to ensure the correct use of the commands. If you took the corrective action but the issue persists, contact the local distributor or technician.
How to clear the alarm?	DI.ARST

**AL255 Second development platform - the system object ID is out of range when the object is used**

Trigger condition and cause	Condition: when the system object is used, the object ID is out of range. Cause: <ol style="list-style-type: none"> <li>1. Incorrect use of the command of the second development platform.</li> <li>2. The EzASD software version and the firmware version do not match.</li> </ol>
-----------------------------	---

14

**AL255 Second development platform - the system object ID is out of range when the object is used**

<p>Checking method and corrective action</p>	<ol style="list-style-type: none"> <li>1. Refer to the command descriptions for the second development platform to ensure the correct use of the commands.</li> <li>2. Check if you are using the latest version of the EzASD software.</li> </ol> <p>If you took the corrective actions but the issue persists, contact the local distributor or technician.</p>
<p>How to clear the alarm?</p>	<p>DI.ARST</p>

**AL257 Second development platform - the system object function block ID is out of range when the object is used**

<p>Trigger condition and cause</p>	<p>Condition: when the system object is used, the object function block ID is out of range.</p> <p>Cause:</p> <ol style="list-style-type: none"> <li>1. Incorrect use of the command of the second development platform.</li> <li>2. The EzASD software version and the firmware version do not match.</li> </ol>
<p>Checking method and corrective action</p>	<ol style="list-style-type: none"> <li>1. Refer to the command descriptions for the second development platform to ensure the correct use of the commands.</li> <li>2. Check if you are using the latest version of the EzASD software.</li> </ol> <p>If you took the corrective actions but the issue persists, contact the local distributor or technician.</p>
<p>How to clear the alarm?</p>	<p>DI.ARST</p>

**AL25B Second development platform - object argument format error**

<p>Trigger condition and cause</p>	<p>Condition: when the system object is used, the argument format of the object is in error.</p> <p>Cause:</p> <ol style="list-style-type: none"> <li>1. Incorrect use of the command of the second development platform.</li> <li>2. The EzASD software version and the firmware version do not match.</li> </ol>
<p>Checking method and corrective action</p>	<p>Refer to the command descriptions for the second development platform to ensure the correct use of the commands. If you took the corrective action but the issue persists, contact the local distributor or technician.</p>
<p>How to clear the alarm?</p>	<p>DI.ARST</p>

<b>AL25F Second development platform - an error occurred when the object dictionary is accessed</b>	
Trigger condition and cause	Condition: when an object dictionary command is used, an error occurred because the value is out of range or the object dictionary does not exist. Cause: when the object dictionary is accessed, the value of the object dictionary is out of range or the firmware does not support the object dictionary.
Checking method and corrective action	Check if the setting for this object dictionary in the program is correct. If you took the corrective action but the issue persists, contact the local distributor or technician.
How to clear the alarm?	DI.ARST
<b>AL261 Second development platform - commands dedicated for the master cannot be used when the master mode is not enabled</b>	
Trigger condition and cause	Condition: when the servo drive is in Modbus slave mode (P3.005.Y = 0), a command dedicated for the master is used. Cause: master mode is not enabled.
Checking method and corrective action	Refer to the command descriptions for the second development platform to ensure the correct use of the commands. If you took the corrective action but the issue persists, contact the local distributor or technician.
How to clear the alarm?	DI.ARST
<b>AL262 Second development platform - read / write address in the master mode is out of range</b>	
Trigger condition and cause	When you use the read / write command in the master mode, the specified address is out of range.
Checking method and corrective action	Refer to the command descriptions for the second development platform to ensure the correct use of the commands. If you took the corrective action but the issue persists, contact the local distributor or technician.
How to clear the alarm?	DI.ARST
<b>AL283 Software positive limit</b>	
Trigger condition and cause	Condition: the feedback position exceeds the software positive limit. Cause: the software positive limit is triggered.
Checking method and corrective action	Software positive limit triggering is determined by the feedback position. Set an appropriate deceleration time to achieve the desired effect. For more information, refer to the description of P5.003.
How to clear the alarm?	The alarm is automatically cleared after the motor moves away from the limit.

<b>AL285 Software negative limit</b>	
Trigger condition and cause	Condition: the feedback position exceeds the software negative limit. Cause: the software negative limit is triggered.
Checking method and corrective action	Software negative limit triggering is determined by the feedback position. Set an appropriate deceleration time to achieve the desired effect. For more information, refer to the description of P5.003.
How to clear the alarm?	The alarm is automatically cleared after the motor moves away from the limit.
<b>AL289 Position counter overflows</b>	
Trigger condition and cause	Position counter overflows.
Checking method and corrective action	<ol style="list-style-type: none"> <li>1. Set the gear ratio according to the actual application requirements and the total traveling distance of the absolute motor to avoid overflow of the feedback counter.</li> <li>2. If P2.069.Z is set to 1 (enabling the function of preventing the rotary axis position from being lost when overflow occurs), set P2.070 [Bit 2] to 1 (no overflow warning).</li> </ol>
How to clear the alarm?	DI.ARST
<b>AL301 CANopen synchronization failure</b>	
Trigger condition and cause	Condition: the synchronization with the controller fails when you use the CANopen IP mode (B mode). Cause: communication fails to synchronize.
Checking method and corrective action	<ol style="list-style-type: none"> <li>1. Make sure the communication between the servo drive and controller is good.</li> <li>2. After eliminating any problems that you find, allow the controller to re-send the synchronization signal and ensure that it is sent successfully.</li> <li>3. Modify the setting for P3.009 (the default value is suggested).</li> </ol>
How to clear the alarm?	NMT: reset node or OD 6040h [Bit 7] (Fault reset).
<b>AL302 Synchronization signal of CANopen is sent too soon</b>	
Trigger condition and cause	Condition: the synchronization signal is received too early when you use the CANopen IP mode (B mode). Cause: the synchronization signal of CANopen is sent too soon.
Checking method and corrective action	<ol style="list-style-type: none"> <li>1. Make sure the setting of communication cycle period (OD 1006h) is identical to that of the controller.</li> <li>2. Modify the synchronization error range setting (P3.009.U). (For A3-M and A3-F models.)</li> </ol>

<b>AL302 Synchronization signal of CANopen is sent too soon</b>	
	<ol style="list-style-type: none"> <li>Ensure the correct time sequence of sending packets from the controller. A drift or delay in packet sending time causes synchronization failure.</li> </ol>
How to clear the alarm?	NMT: reset node or OD 6040h [Bit 7] (Fault reset).
<b>AL303 CANopen synchronization signal timeout</b>	
Trigger condition and cause	<p>Condition: the synchronization with the controller fails when you use the CANopen IP mode (B mode).</p> <p>Cause: timeout of CANopen synchronization signal.</p>
Checking method and corrective action	<ol style="list-style-type: none"> <li>Make sure the communication between the servo drive and controller is good.</li> <li>Make sure the setting of communication cycle period (OD 1006h) is identical to that of the controller.</li> <li>Modify the synchronization error range setting (P3.009.U). (For A3-M and A3-F models.)</li> <li>Ensure the correct time sequence of sending packets from the controller. A drift or delay in packet sending time causes synchronization failure.</li> <li>When the servo drive is in the operation mode of PV (Profile velocity mode), PT (Profile torque mode), or HM (Homing mode), check if P3.017 is set too low.</li> </ol>
How to clear the alarm?	NMT: reset node or OD 6040h [Bit 7] (Fault reset).
<b>AL304 Invalid interpolation mode command</b>	
Trigger condition and cause	<p>Condition: the servo drive cannot send the command when in IP mode (except the CANopen B mode).</p> <p>Cause: the interpolation command fails.</p>
Checking method and corrective action	The computing time takes too long. Disable the USB monitoring function.
How to clear the alarm?	NMT: reset node or OD 6040h [Bit 7] (Fault reset).
<b>AL305 SYNC period error</b>	
Trigger condition and cause	<p>Condition: CANopen 301 OD 1006h data error.</p> <p>Cause: SYNC period is in error.</p>
Checking method and corrective action	Check the value of OD 1006h. If it is smaller than or equal to 0, this alarm occurs.
How to clear the alarm?	NMT: reset node or OD 6040h [Bit 7] (Fault reset).



<b>AL35F Emergency stop during deceleration</b>	
Trigger condition and cause	The rising edge of DI: 0x47 is triggered, and then the motor decelerates to 0 and triggers AL3CF.
Checking method and corrective action	Check if the DI is set to 0x47 with any of the parameters, P2.010 - P2.017 and P2.036 - P2.040, and is triggered.
How to clear the alarm?	Cycle power on the servo drive.

<b>AL380 Position offset alarm for DO.MC_OK</b>	
Trigger condition and cause	DO.MC_OK is on and then goes off.
Checking method and corrective action	Refer to the description of P1.048. After DO.MC_OK is on, DO.MC_OK then goes off because DO.TPOS turns off. There might be an external force causing the position offset of the motor after positioning is complete. Disable this alarm by setting P1.048.Y to 0.
How to clear the alarm?	DI.ARST

<b>AL3CF Emergency stop</b>	
Trigger condition and cause	After AL35F is triggered and the motor has decelerated to 0, this alarm occurs.
Checking method and corrective action	Check if the DI is set to 0x47 with any of the parameters, P2.010 - P2.017 and P2.036 - P2.040, and is triggered.
How to clear the alarm?	DI.ARST

<b>AL3E1 Communication fails to synchronize</b>	
Trigger condition and cause	Condition: the communication synchronization with the controller fails in IP mode (except the CANopen B mode). Cause: communication fails to synchronize.
Checking method and corrective action	<ol style="list-style-type: none"> <li>1. Make sure the communication between the servo drive and controller is good.</li> <li>2. After eliminating any problems that you find, allow the controller to re-send the synchronization signal and ensure that it is sent successfully.</li> <li>3. Modify the setting for P3.009 (the default value is suggested).</li> </ol>
How to clear the alarm?	NMT: reset node or OD 6040h [Bit 7] (Fault reset).

<b>AL3E2 Communication synchronization signal is sent too soon</b>	
Trigger condition and cause	Condition: the synchronization signal is received too early. Cause: the communication synchronization signal is sent too soon.
Checking method and corrective action	<ol style="list-style-type: none"> <li>1. Make sure the setting of communication cycle period (OD 1006h) is identical to that of the controller.</li> <li>2. Modify the synchronization error range setting (P3.009.U). (For A3-M and A3-F models.)</li> <li>3. Ensure the correct time sequence of sending packets from the controller. A drift or delay in packet sending time causes synchronization failure.</li> </ol>
How to clear the alarm?	NMT: reset node or OD 6040h [Bit 7] (Fault reset).

<b>AL3E3 Communication synchronization signal timeout</b>	
Trigger condition and cause	The target command is not received within a continuous communication cycle in IP mode (except the CANopen B mode).
Checking method and corrective action	<ol style="list-style-type: none"> <li>1. Make sure the communication between the servo drive and controller is good.</li> <li>2. Make sure the setting of communication cycle period (OD 1006h) is identical to that of the controller.</li> <li>3. Modify the synchronization error range setting (P3.009.U). (For A3-M and A3-F models.)</li> <li>4. Modify the setting of IP command timeout (P3.022.YX). (For A3-E models.)</li> <li>5. Ensure the correct time sequence of sending packets from the controller. A drift or delay in packet sending time causes synchronization failure.</li> </ol>
How to clear the alarm?	NMT: reset node or OD 6040h [Bit 7] (fault reset).

<b>AL3F1 Absolute position command of the communication type servo drive is in error</b>	
Trigger condition and cause	Condition: when the bus communication type (CANopen, DMCNET, and EtherCAT) servo drive is in combination with an incremental motor and the position overflow occurs with the absolute origin position not established, the absolute positioning command is issued. Cause: <ol style="list-style-type: none"> <li>1. The absolute origin position is not established.</li> <li>2. Overflow occurs since the motor keeps rotating in the same direction.</li> </ol>
Checking method and corrective action	Establish the absolute origin position.
How to clear the alarm?	Establish the absolute origin position.

<b>AL400 Roaty axis position setting error</b>	
Trigger condition and cause	Condition: the position offset of the motor in 1 ms exceeds the setting of P2.052 (Rotary axis position scale). Cause: the value of P2.052 is set too small.
Checking method and corrective action	Check if P2.052 is set according to the specifications in the manual.
How to clear the alarm?	DI.ARST

<b>AL401 NMT reset command is received when servo is on</b>	
Trigger condition and cause	NMT reset command is received when the servo is on.
Checking method and corrective action	Check if the NMT reset command is received when the servo is on. Use NMT: reset node or OD 6040h [Bit 7] (Fault reset).
How to clear the alarm?	DI.ARST

<b>AL404 PR special filter setting value is too great</b>	
Trigger condition and cause	Condition: the value of the PR command special filter (P1.022) is set too great causing the following error of the internal position to exceed the allowable range. Cause: the following error of the internal position exceeds the allowable range.
Checking method and corrective action	Check the setting of P1.022. If the value is too great, the following error exceeds the allowable range in a short time. Adjust the value of P1.022.
How to clear the alarm?	DI.ARST

<b>AL422 Write-in failed caused by power supply cut-off</b>	
Trigger condition and cause	Condition: if P2.069.Z is set to 1 (enabling the function of preventing the rotary axis position from being lost when overflow occurs) and the power supply is cut off, the motor fails to store the current position. Cause: <ol style="list-style-type: none"> <li>1. The load is over the rated range and the servo drive is in a continuous overload condition.</li> <li>2. After firmware update, the internal variables vary from versions.</li> <li>3. The servo drive hardware EEPROM is abnormal.</li> <li>4. The hardware of the servo drive is short-circuited.</li> <li>5. AL520 occurred and causes malfunction of the servo drive.</li> </ol>
Checking method and corrective action	<ol style="list-style-type: none"> <li>1. Set P0.002 to 12 for monitoring if the average load rate [%] is continuously over 100%. If so, increase the motor capacity or reduce the load. Refer to Appendix A for Graph of load and operating time.</li> </ol>

<b>AL422 Write-in failed caused by power supply cut-off</b>	
	2. If the issue persists, send your servo drive back to the distributor or contact Delta.
How to clear the alarm?	Cycle power on the servo drive.

<b>AL500 STO function is enabled</b>	
Trigger condition and cause	Safe torque off function (STO) is enabled.
Checking method and corrective action	Safe torque off function (STO) is enabled. Check why it is enabled.
How to clear the alarm?	<ol style="list-style-type: none"> <li>1. Reset by using DI.ARST (Alarm reset), OD 6040h [Bit 7] (Fault reset), or setting P0.001 to 0.</li> <li>2. If not using the STO function, plug the short circuit connector into CN10 or wire to short-circuit the CN10 STO connector. Follow the instructions in Chapter 3 for the STO wiring.</li> </ol>

<b>AL501 SF1 lost (signal loss or signal error)</b>	
Trigger condition and cause	Loss of SF1 signal, or SF1 and SF2 signals are not synchronized for more than 1 second.
Checking method and corrective action	Make sure the wiring of SF1 is correct.
How to clear the alarm?	Cycle power on the servo drive. If the alarm cannot be cleared, keep the servo drive in the safe state and contact the distributor.

<b>AL502 SF2 lost (signal loss or signal error)</b>	
Trigger condition and cause	Loss of SF2 signal, or SF1 and SF2 signals are not synchronized for more than 1 second.
Checking method and corrective action	Make sure the wiring of SF2 is correct.
How to clear the alarm?	Cycle power on the servo drive. If the alarm cannot be cleared, keep the servo drive in the safe state and contact the distributor.

<b>AL503 STO self-diagnostic error</b>	
Trigger condition and cause	An error occurs during STO self-diagnosis, which may be caused by an abnormality in the STO circuit.
Checking method and corrective action	N/A
How to clear the alarm?	Contact the distributor.

AL510 Internal parameter update program of the servo drive is abnormal	
Trigger condition and cause	Internal parameter update program of the servo drive is abnormal.
Checking method and corrective action	If this alarm occurs when the motor parameter identification function is executing, cycle power on the servo drive and re-execute the motor parameter identification function.
How to clear the alarm?	N/A

AL520 Calculation program timeout	
Trigger condition and cause	Servo drive calculation program timeout.
Checking method and corrective action	<ol style="list-style-type: none"> <li>1. Cycle power on the servo drive.</li> <li>2. If the alarm persists, disable the vibration elimination function by setting [Bit 8] and [Bit 9] of P2.094 to 0.</li> </ol>
How to clear the alarm?	N/A

AL521 Vibration elimination parameter error	
Trigger condition and cause	<p>Condition: the input value for the vibration elimination parameter is not appropriate.</p> <p>Cause:</p> <ol style="list-style-type: none"> <li>1. Your input value for the vibration elimination parameter is not appropriate.</li> <li>2. The Bode plot is in error due to other factors when the <b>System Analysis</b> tool is in operation.</li> </ol>
Checking method and corrective action	Perform system analysis again and correctly set the value for the vibration elimination parameter.
How to clear the alarm?	<ol style="list-style-type: none"> <li>1. Perform system analysis again and correctly set the value for the vibration elimination parameter.</li> <li>2. If the issue persists, disable the vibration elimination function by setting [Bit 8] and [Bit 9] of P2.094 to 0.</li> </ol>

AL555 System failure	
Trigger condition and cause	Servo drive DSP is in error.
Checking method and corrective action	If this alarm occurs, send your servo drive directly back to Delta without making any modification.
How to clear the alarm?	N/A

<b>AL809 PR arithmetic operation error or second development platform error</b>	
Trigger condition and cause	<p>Condition: an error occurs when the servo drive decodes the motion command.</p> <p>Cause: the PR arithmetic operation must be compiled by the ASDA-Soft software before being downloaded to the servo drive. Editing or modifying the PR arithmetic operation parameters through the panel or controller without compiling them by ASDA-Soft triggers AL809.</p>
Checking method and corrective action	<ol style="list-style-type: none"> <li>1. Make sure you edit the PR arithmetic operation parameters through ASDA-Soft. Do not modify these parameters through the panel or controller.</li> <li>2. If this alarm occurs when the servo is not in the PR mode, save the parameter file and provide it to the distributor.</li> <li>3. For advanced users: save the scope screenshot when the alarm occurs. Set P5.007 and P0.001 for the two channels and save the oscillogram.</li> </ol>
How to clear the alarm?	Cycle power on the servo drive.

<b>ALC31 Motor power cable disconnection</b>	
Trigger condition and cause	<p>Condition: disconnection of the motor power cable (U, V, W) and ground wire (GND).</p> <p>Cause: disconnection of the motor power cable (U, V, W) and ground wire (GND). The switch for disconnection detection is set by P2.065 [Bit 9], which is enabled by default.</p>
Checking method and corrective action	Check if the motor power cable (U, V, W) and ground wire (GND) are firmly connected. Follow the instructions in this user manual to properly connect the motor power cable and ground wire.
How to clear the alarm?	Cycle power on the servo drive.

<b>ALD00 MITUTOYO encoder - overspeed</b>	
Trigger condition and cause	<p>Condition: an error occurred to the MITUTOYO encoder.</p> <p>Cause:</p> <ol style="list-style-type: none"> <li>1. The motor speed exceeds 3 m/s.</li> <li>2. The installation or wiring of the encoder is incorrect.</li> <li>3. The installation and operating environment do not meet the specifications, causing encoder error.</li> <li>4. The encoder is damaged.</li> </ol>
Checking method and corrective action	<ol style="list-style-type: none"> <li>1. Make sure the encoder or read head is correctly installed and wired according to the manufacturer's instruction manual.</li> <li>2. If the issue persists, contact the distributor of the encoder.</li> </ol>
How to clear the alarm?	DI.ARST or cycle power on the servo drive.

<b>ALD01 MITUTOYO encoder - initialization error</b>	
Trigger condition and cause	<p>Condition: an error occurred to the MITUTOYO encoder.</p> <p>Cause:</p> <ol style="list-style-type: none"> <li>1. Initialization status error.</li> <li>2. The installation or wiring of the encoder is incorrect.</li> <li>3. The installation and operating environment do not meet the specifications, causing encoder error.</li> <li>4. The encoder is damaged.</li> </ol>
Checking method and corrective action	<ol style="list-style-type: none"> <li>1. Make sure the encoder or read head is correctly installed and wired according to the manufacturer's instruction manual.</li> <li>2. If the issue persists, contact the distributor of the encoder.</li> </ol>
How to clear the alarm?	DI.ARST or cycle power on the servo drive.

<b>ALD02 MITUTOYO encoder - hardware error</b>	
Trigger condition and cause	<p>Condition: an error occurred to the MITUTOYO encoder.</p> <p>Cause:</p> <ol style="list-style-type: none"> <li>1. The encoder hardware signal is in error.</li> <li>2. The installation or wiring of the encoder is incorrect.</li> <li>3. The installation and operating environment do not meet the specifications, causing encoder error.</li> <li>4. The encoder is damaged.</li> </ol>

<b>ALD02 MITUTOYO encoder - hardware error</b>	
Checking method and corrective action	<ol style="list-style-type: none"> <li>1. Make sure the encoder or read head is correctly installed and wired according to the manufacturer's instruction manual.</li> <li>2. If the issue persists, contact the distributor of the encoder.</li> </ol>
How to clear the alarm?	DI.ARST or cycle power on the servo drive.

<b>ALD03 MITUTOYO encoder - absolute position detection error</b>	
Trigger condition and cause	<p>Condition: an error occurred to the MITUTOYO encoder.</p> <p>Cause:</p> <ol style="list-style-type: none"> <li>1. The absolute position is in error.</li> <li>2. The installation or wiring of the encoder is incorrect.</li> <li>3. The installation and operating environment do not meet the specifications, causing encoder error.</li> <li>4. The encoder is damaged.</li> </ol>
Checking method and corrective action	<ol style="list-style-type: none"> <li>1. Make sure the encoder or read head is correctly installed and wired according to the manufacturer's instruction manual.</li> <li>2. If the issue persists, contact the distributor of the encoder.</li> </ol>
How to clear the alarm?	DI.ARST or cycle power on the servo drive.

<b>ALD04 MITUTOYO encoder - sensor or read head error</b>	
Trigger condition and cause	<p>Condition: an error occurred to the MITUTOYO encoder.</p> <p>Cause:</p> <ol style="list-style-type: none"> <li>1. The sensor signal is in error.</li> <li>2. The installation or wiring of the encoder is incorrect.</li> <li>3. The installation and operating environment do not meet the specifications, causing encoder error.</li> <li>4. The encoder is damaged.</li> </ol>
Checking method and corrective action	<ol style="list-style-type: none"> <li>1. Make sure the encoder or read head is correctly installed and wired according to the manufacturer's instruction manual.</li> <li>2. If the issue persists, contact the distributor of the encoder.</li> </ol>
How to clear the alarm?	DI.ARST or cycle power on the servo drive.



<b>ALD05 MITUTOYO encoder - sensor signal strength error</b>	
Trigger condition and cause	<p>Condition: an error occurred to the MITUTOYO encoder.</p> <p>Cause:</p> <ol style="list-style-type: none"> <li>1. The signal strength of the sensor is in error and the position data may contain errors.</li> <li>2. The installation or wiring of the encoder is incorrect.</li> <li>3. The installation and operating environment do not meet the specifications, causing encoder error.</li> <li>4. The encoder is damaged.</li> </ol>
Checking method and corrective action	<ol style="list-style-type: none"> <li>1. Make sure the encoder or read head is correctly installed and wired according to the manufacturer's instruction manual.</li> <li>2. If the issue persists, contact the distributor of the encoder.</li> </ol>
How to clear the alarm?	DI.ARST or cycle power on the servo drive.

<b>ALD06 MITUTOYO encoder - sensor signal strength warning</b>	
Trigger condition and cause	<p>Condition: an error occurred to the MITUTOYO encoder.</p> <p>Cause:</p> <ol style="list-style-type: none"> <li>1. The signal strength of the sensor is in error, but the position data does not contain errors.</li> <li>2. The installation or wiring of the encoder is incorrect.</li> <li>3. The installation and operating environment do not meet the specifications, causing encoder error.</li> <li>4. The encoder is damaged.</li> </ol>
Checking method and corrective action	<ol style="list-style-type: none"> <li>1. Make sure the encoder or read head is correctly installed and wired according to the manufacturer's instruction manual.</li> <li>2. If the issue persists, contact the distributor of the encoder.</li> </ol>
How to clear the alarm?	DI.ARST or cycle power on the servo drive.

<b>ALD07 MITUTOYO encoder - temperature warning</b>	
Trigger condition and cause	<p>Condition: an error occurred to the MITUTOYO encoder.</p> <p>Cause:</p> <ol style="list-style-type: none"> <li>1. The internal temperature of the encoder is over 65°C (149°F).</li> <li>2. The installation or wiring of the encoder is incorrect.</li> <li>3. The installation and operating environment do not meet the specifications, causing encoder error.</li> <li>4. The encoder is damaged.</li> </ol>

<b>ALD07 MITUTOYO encoder - temperature warning</b>	
Checking method and corrective action	<ol style="list-style-type: none"> <li>1. Make sure the encoder or read head is correctly installed and wired according to the manufacturer's instruction manual.</li> <li>2. If the issue persists, contact the distributor of the encoder.</li> </ol>
How to clear the alarm?	DI.ARST or cycle power on the servo drive.

<b>ALD08 BiSS C encoder - sensor installation error</b>	
Trigger condition and cause	<p>Condition: an error occurred to the BiSS C encoder.</p> <p>Cause:</p> <ol style="list-style-type: none"> <li>1. The installation or wiring of the encoder is incorrect.</li> <li>2. The installation and operating environment do not meet the specifications, causing encoder error.</li> <li>3. The encoder is damaged.</li> </ol>
Checking method and corrective action	<ol style="list-style-type: none"> <li>1. Make sure the encoder or read head is correctly installed and wired according to the manufacturer's instruction manual.</li> <li>2. If the issue persists, contact the distributor of the encoder.</li> </ol>
How to clear the alarm?	DI.ARST or cycle power on the servo drive.

<b>ALD09 BiSS C encoder - sensor installation warning</b>	
Trigger condition and cause	<p>Condition: an error occurred to the BiSS C encoder.</p> <p>Cause:</p> <ol style="list-style-type: none"> <li>1. The installation or wiring of the encoder is incorrect.</li> <li>2. The installation and operating environment do not meet the specifications, causing encoder error.</li> <li>3. The encoder is damaged.</li> </ol>
Checking method and corrective action	<ol style="list-style-type: none"> <li>1. Make sure the encoder or read head is correctly installed and wired according to the manufacturer's instruction manual.</li> <li>2. If the issue persists, contact the distributor of the encoder.</li> </ol>
How to clear the alarm?	DI.ARST or cycle power on the servo drive.

14

ALD16 EnDat 2.2 encoder - sensor installation error	
Trigger condition and cause	<p>Condition: an error occurred to the EnDat 2.2 encoder.</p> <p>Cause:</p> <ol style="list-style-type: none"> <li>1. The installation or wiring of the encoder is incorrect.</li> <li>2. The installation and operating environment do not meet the specifications, causing encoder error.</li> <li>3. The encoder is damaged.</li> </ol>
Checking method and corrective action	<ol style="list-style-type: none"> <li>1. Make sure the encoder or read head is correctly installed and wired according to the manufacturer's instruction manual.</li> <li>2. If the issue persists, contact the distributor of the encoder.</li> </ol>
How to clear the alarm?	DI.ARST or cycle power on the servo drive.

ALD17 EnDat 2.2 encoder - sensor signal strength error	
Trigger condition and cause	<p>Condition: an error occurred to the EnDat 2.2 encoder.</p> <p>Cause:</p> <ol style="list-style-type: none"> <li>1. The installation or wiring of the encoder is incorrect.</li> <li>2. The installation and operating environment do not meet the specifications, causing encoder error.</li> <li>3. The encoder is damaged.</li> </ol>
Checking method and corrective action	<ol style="list-style-type: none"> <li>1. Make sure the encoder or read head is correctly installed and wired according to the manufacturer's instruction manual.</li> <li>2. If the issue persists, contact the distributor of the encoder.</li> </ol>
How to clear the alarm?	DI.ARST or cycle power on the servo drive.

<b>ALD18 EnDat 2.2 encoder - position error</b>	
Trigger condition and cause	<p>Condition: an error occurred to the EnDat 2.2 encoder.</p> <p>Cause:</p> <ol style="list-style-type: none"> <li>1. The installation or wiring of the encoder is incorrect.</li> <li>2. The installation and operating environment do not meet the specifications, causing encoder error.</li> <li>3. The encoder is damaged.</li> </ol>
Checking method and corrective action	<ol style="list-style-type: none"> <li>1. Make sure the encoder or read head is correctly installed and wired according to the manufacturer's instruction manual.</li> <li>2. If the issue persists, contact the distributor of the encoder.</li> </ol>
How to clear the alarm?	DI.ARST or cycle power on the servo drive.

<b>ALD19 EnDat 2.2 encoder - overvoltage</b>	
Trigger condition and cause	<p>Condition: an error occurred to the EnDat 2.2 encoder.</p> <p>Cause:</p> <ol style="list-style-type: none"> <li>1. The installation or wiring of the encoder is incorrect.</li> <li>2. The installation and operating environment do not meet the specifications, causing encoder error.</li> <li>3. The encoder is damaged.</li> </ol>
Checking method and corrective action	<ol style="list-style-type: none"> <li>1. Make sure the encoder or read head is correctly installed and wired according to the manufacturer's instruction manual.</li> <li>2. If the issue persists, contact the distributor of the encoder.</li> </ol>
How to clear the alarm?	DI.ARST or cycle power on the servo drive.

<b>ALD20 EnDat 2.2 encoder - undervoltage</b>	
Trigger condition and cause	<p>Condition: an error occurred to the EnDat 2.2 encoder.</p> <p>Cause:</p> <ol style="list-style-type: none"> <li>1. The installation or wiring of the encoder is incorrect.</li> <li>2. The installation and operating environment do not meet the specifications, causing encoder error.</li> <li>3. The encoder is damaged.</li> </ol>
Checking method and corrective action	<ol style="list-style-type: none"> <li>1. Make sure the encoder or read head is correctly installed and wired according to the manufacturer's instruction manual.</li> <li>2. If the issue persists, contact the distributor of the encoder.</li> </ol>
How to clear the alarm?	DI.ARST or cycle power on the servo drive.

<b>ALD21 EnDat 2.2 encoder - overcurrent</b>	
Trigger condition and cause	<p>Condition: an error occurred to the EnDat 2.2 encoder.</p> <p>Cause:</p> <ol style="list-style-type: none"> <li>1. The installation or wiring of the encoder is incorrect.</li> <li>2. The installation and operating environment do not meet the specifications, causing encoder error.</li> <li>3. The encoder is damaged.</li> </ol>
Checking method and corrective action	<ol style="list-style-type: none"> <li>1. Make sure the encoder or read head is correctly installed and wired according to the manufacturer's instruction manual.</li> <li>2. If the issue persists, contact the distributor of the encoder.</li> </ol>
How to clear the alarm?	DI.ARST or cycle power on the servo drive.

<b>ALD22 EnDat 2.2 encoder - low battery voltage</b>	
Trigger condition and cause	<p>Condition: an error occurred to the EnDat 2.2 encoder.</p> <p>Cause:</p> <ol style="list-style-type: none"> <li>1. The installation or wiring of the encoder is incorrect.</li> <li>2. The installation and operating environment do not meet the specifications, causing encoder error.</li> <li>3. The encoder is damaged.</li> </ol>
Checking method and corrective action	<ol style="list-style-type: none"> <li>1. Make sure the encoder or read head is correctly installed and wired according to the manufacturer's instruction manual.</li> <li>2. If the issue persists, contact the distributor of the encoder.</li> </ol>
How to clear the alarm?	DI.ARST or cycle power on the servo drive.

<b>ALD23 EnDat 2.2 encoder - frequency collision warning</b>	
Trigger condition and cause	<p>Condition: an error occurred to the EnDat 2.2 encoder.</p> <p>Cause:</p> <ol style="list-style-type: none"> <li>1. The installation or wiring of the encoder is incorrect.</li> <li>2. The installation and operating environment do not meet the specifications, causing encoder error.</li> <li>3. The encoder is damaged.</li> </ol>
Checking method and corrective action	<ol style="list-style-type: none"> <li>1. Make sure the encoder or read head is correctly installed and wired according to the manufacturer's instruction manual.</li> <li>2. If the issue persists, contact the distributor of the encoder.</li> </ol>
How to clear the alarm?	DI.ARST or cycle power on the servo drive.

14

<b>ALD24 EnDat 2.2 encoder - temperature warning</b>	
Trigger condition and cause	<p>Condition: an error occurred to the EnDat 2.2 encoder.</p> <p>Cause:</p> <ol style="list-style-type: none"> <li>1. The installation or wiring of the encoder is incorrect.</li> <li>2. The installation and operating environment do not meet the specifications, causing encoder error.</li> <li>3. The encoder is damaged.</li> </ol>
Checking method and corrective action	<ol style="list-style-type: none"> <li>1. Make sure the encoder or read head is correctly installed and wired according to the manufacturer's instruction manual.</li> <li>2. If the issue persists, contact the distributor of the encoder.</li> </ol>
How to clear the alarm?	DI.ARST or cycle power on the servo drive.

<b>ALD25 EnDat 2.2 encoder - sensor signal strength warning</b>	
Trigger condition and cause	<p>Condition: an error occurred to the EnDat 2.2 encoder.</p> <p>Cause:</p> <ol style="list-style-type: none"> <li>1. The installation or wiring of the encoder is incorrect.</li> <li>2. The installation and operating environment do not meet the specifications, causing encoder error.</li> <li>3. The encoder is damaged.</li> </ol>
Checking method and corrective action	<ol style="list-style-type: none"> <li>1. Make sure the encoder or read head is correctly installed and wired according to the manufacturer's instruction manual.</li> <li>2. If the issue persists, contact the distributor of the encoder.</li> </ol>
How to clear the alarm?	DI.ARST or cycle power on the servo drive.

<b>ALD26 EnDat 2.2 encoder - low battery voltage warning</b>	
Trigger condition and cause	<p>Condition: an error occurred to the EnDat 2.2 encoder.</p> <p>Cause:</p> <ol style="list-style-type: none"> <li>1. The installation or wiring of the encoder is incorrect.</li> <li>2. The installation and operating environment do not meet the specifications, causing encoder error.</li> <li>3. The encoder is damaged.</li> </ol>
Checking method and corrective action	<ol style="list-style-type: none"> <li>1. Make sure the encoder or read head is correctly installed and wired according to the manufacturer's instruction manual.</li> <li>2. If the issue persists, contact the distributor of the encoder.</li> </ol>
How to clear the alarm?	DI.ARST or cycle power on the servo drive.

<b>ALD27 EnDat 2.2 encoder - warning of the reference point error</b>	
Trigger condition and cause	<p>Condition: an error occurred to the EnDat 2.2 encoder.</p> <p>Cause:</p> <ol style="list-style-type: none"> <li>1. The installation or wiring of the encoder is incorrect.</li> <li>2. The installation and operating environment do not meet the specifications, causing encoder error.</li> <li>3. The encoder is damaged.</li> </ol>
Checking method and corrective action	<ol style="list-style-type: none"> <li>1. Make sure the encoder or read head is correctly installed and wired according to the manufacturer's instruction manual.</li> <li>2. If the issue persists, contact the distributor of the encoder.</li> </ol>
How to clear the alarm?	DI.ARST or cycle power on the servo drive.



14

<b>ALD28 EnDat 2.2 encoder - cyclic mode warning</b>	
Trigger condition and cause	<p>Condition: an error occurred to the EnDat 2.2 encoder.</p> <p>Cause:</p> <ol style="list-style-type: none"> <li>1. The installation or wiring of the encoder is incorrect.</li> <li>2. The installation and operating environment do not meet the specifications, causing encoder error.</li> <li>3. The encoder is damaged.</li> </ol>
Checking method and corrective action	<ol style="list-style-type: none"> <li>1. Make sure the encoder or read head is correctly installed and wired according to the manufacturer's instruction manual.</li> <li>2. If the issue persists, contact the distributor of the encoder.</li> </ol>
How to clear the alarm?	DI.ARST or cycle power on the servo drive.

<b>ALD29 EnDat 2.2 encoder - position limit warning</b>	
Trigger condition and cause	<p>Condition: an error occurred to the EnDat 2.2 encoder.</p> <p>Cause:</p> <ol style="list-style-type: none"> <li>1. The installation or wiring of the encoder is incorrect.</li> <li>2. The installation and operating environment do not meet the specifications, causing encoder error.</li> <li>3. The encoder is damaged.</li> </ol>
Checking method and corrective action	<ol style="list-style-type: none"> <li>1. Make sure the encoder or read head is correctly installed and wired according to the manufacturer's instruction manual.</li> <li>2. If the issue persists, contact the distributor of the encoder.</li> </ol>
How to clear the alarm?	DI.ARST

<b>ALD30 EnDat 2.2 encoder - readiness warning</b>	
Trigger condition and cause	<p>Condition: an error occurred to the EnDat 2.2 encoder.</p> <p>Cause:</p> <ol style="list-style-type: none"> <li>1. The installation or wiring of the encoder is incorrect.</li> <li>2. The installation and operating environment do not meet the specifications, causing encoder error.</li> <li>3. The encoder is damaged.</li> </ol>
Checking method and corrective action	<ol style="list-style-type: none"> <li>1. Make sure the encoder or read head is correctly installed and wired according to the manufacturer's instruction manual.</li> <li>2. If the issue persists, contact the distributor of the encoder.</li> </ol>
How to clear the alarm?	DI.ARST

<b>ALD31 EnDat 2.2 encoder - diagnostic warning</b>	
Trigger condition and cause	<p>Condition: an error occurred to the EnDat 2.2 encoder.</p> <p>Cause:</p> <ol style="list-style-type: none"> <li>1. The installation or wiring of the encoder is incorrect.</li> <li>2. The installation and operating environment do not meet the specifications, causing encoder error.</li> <li>3. The encoder is damaged.</li> </ol>
Checking method and corrective action	<ol style="list-style-type: none"> <li>1. Make sure the encoder or read head is correctly installed and wired according to the manufacturer's instruction manual.</li> <li>2. If the issue persists, contact the distributor of the encoder.</li> </ol>
How to clear the alarm?	DI.ARST

ALE00 Fagor encoder - CPU error	
Trigger condition and cause	<p>Condition: an error occurred to the Fagor encoder.</p> <p>Cause:</p> <ol style="list-style-type: none"> <li>1. The installation or wiring of the encoder is incorrect.</li> <li>2. The installation and operating environment do not meet the specifications, causing encoder error.</li> <li>3. The encoder is damaged.</li> </ol>
Checking method and corrective action	<ol style="list-style-type: none"> <li>1. Make sure the encoder or read head is correctly installed and wired according to the manufacturer's instruction manual.</li> <li>2. If the issue persists, contact the distributor of the encoder.</li> </ol>
How to clear the alarm?	DI.ARST

ALE01 Fagor encoder - parameter error	
Trigger condition and cause	<p>Condition: an error occurred to the Fagor encoder.</p> <p>Cause:</p> <ol style="list-style-type: none"> <li>1. The installation or wiring of the encoder is incorrect.</li> <li>2. The installation and operating environment do not meet the specifications, causing encoder error.</li> <li>3. The encoder is damaged.</li> </ol>
Checking method and corrective action	<ol style="list-style-type: none"> <li>1. Make sure the encoder or read head is correctly installed and wired according to the manufacturer's instruction manual.</li> <li>2. If the issue persists, contact the distributor of the encoder.</li> </ol>
How to clear the alarm?	DI.ARST

ALE02 Fagor encoder - CCD error	
Trigger condition and cause	<p>Condition: an error occurred to the Fagor encoder.</p> <p>Cause:</p> <ol style="list-style-type: none"> <li>1. The installation or wiring of the encoder is incorrect.</li> <li>2. The installation and operating environment do not meet the specifications, causing encoder error.</li> <li>3. The encoder is damaged.</li> </ol>
Checking method and corrective action	<ol style="list-style-type: none"> <li>1. Make sure the encoder or read head is correctly installed and wired according to the manufacturer's instruction manual.</li> <li>2. If the issue persists, contact the distributor of the encoder.</li> </ol>
How to clear the alarm?	DI.ARST

ALE03 Fagor encoder - position error	
Trigger condition and cause	<p>Condition: an error occurred to the Fagor encoder.</p> <p>Cause:</p> <ol style="list-style-type: none"> <li>1. Analog signal of the sensor &lt; 0.2 Vpp.</li> <li>2. The installation or wiring of the encoder is incorrect.</li> <li>3. The installation and operating environment do not meet the specifications, causing encoder error.</li> <li>4. The encoder is damaged.</li> </ol>
Checking method and corrective action	<ol style="list-style-type: none"> <li>1. Make sure the encoder or read head is correctly installed and wired according to the manufacturer's instruction manual.</li> <li>2. If the issue persists, contact the distributor of the encoder.</li> </ol>
How to clear the alarm?	DI.ARST

14

<b>ALE04 Fagor encoder - sensor signal strength warning</b>	
Trigger condition and cause	<p>Condition: an error occurred to the Fagor encoder.</p> <p>Cause:</p> <ol style="list-style-type: none"> <li>1. Analog signal of the sensor &lt; 0.4 Vpp.</li> <li>2. The installation or wiring of the encoder is incorrect.</li> <li>3. The installation and operating environment do not meet the specifications, causing encoder error.</li> <li>4. The encoder is damaged.</li> </ol>
Checking method and corrective action	<ol style="list-style-type: none"> <li>1. Make sure the encoder or read head is correctly installed and wired according to the manufacturer's instruction manual.</li> <li>2. If the issue persists, contact the distributor of the encoder.</li> </ol>
How to clear the alarm?	DI.ARST

<b>ALE05 Fagor encoder - voltage warning</b>	
Trigger condition and cause	<p>Condition: an error occurred to the Fagor encoder.</p> <p>Cause:</p> <ol style="list-style-type: none"> <li>1. The encoder voltage is abnormal.</li> <li>2. The installation or wiring of the encoder is incorrect.</li> <li>3. The installation and operating environment do not meet the specifications, causing encoder error.</li> <li>4. The encoder is damaged.</li> </ol>
Checking method and corrective action	<ol style="list-style-type: none"> <li>1. Make sure the encoder or read head is correctly installed and wired according to the manufacturer's instruction manual.</li> <li>2. If the issue persists, contact the distributor of the encoder.</li> </ol>
How to clear the alarm?	DI.ARST

<b>ALE06 Fagor encoder - overspeed warning</b>	
Trigger condition and cause	<p>Condition: an error occurred to the Fagor encoder.</p> <p>Cause:</p> <ol style="list-style-type: none"> <li>1. The motor speed is too fast and has exceeded the maximum value of the encoder.</li> <li>2. The installation or wiring of the encoder is incorrect.</li> <li>3. The installation and operating environment do not meet the specifications, causing encoder error.</li> <li>4. The encoder is damaged.</li> </ol>
Checking method and corrective action	<ol style="list-style-type: none"> <li>1. Make sure the encoder or read head is correctly installed and wired according to the manufacturer's instruction manual.</li> <li>2. If the issue persists, contact the distributor of the encoder.</li> </ol>
How to clear the alarm?	DI.ARST

<b>ALE07 Fagor encoder - temperature warning</b>	
Trigger condition and cause	<p>Condition: an error occurred to the Fagor encoder.</p> <p>Cause:</p> <ol style="list-style-type: none"> <li>1. The encoder temperature has exceeded the maximum value.</li> <li>2. The installation or wiring of the encoder is incorrect.</li> <li>3. The installation and operating environment do not meet the specifications, causing encoder error.</li> <li>4. The encoder is damaged.</li> </ol>
Checking method and corrective action	<ol style="list-style-type: none"> <li>1. Make sure the encoder or read head is correctly installed and wired according to the manufacturer's instruction manual.</li> <li>2. If the issue persists, contact the distributor of the encoder.</li> </ol>
How to clear the alarm?	DI.ARST

14

ALF21 Second development platform command error																																																							
Trigger condition and cause	<p>Condition: the use of the second development platform commands does not comply with the specifications.</p> <p>Cause: refer to the error codes.</p>																																																						
Checking method and corrective action	<p>View the error code by checking the ERR register with the EzASD software or by pressing the SHIFT key (◀) when the panel displays ALF21.</p> <table border="1" style="width: 100%; border-collapse: collapse;"> <thead> <tr> <th style="width: 15%;">Error code</th> <th>Description</th> </tr> </thead> <tbody> <tr> <td>0x0203</td> <td>Task number is out of range when the command for configuring the task is used.</td> </tr> <tr> <td>0x0207</td> <td>The parameter group (grp) value of the LACC_PR or SACC_PR command is out of range.</td> </tr> <tr> <td>0x0209</td> <td>The parameter index (idx) value of the LACC_PR or SACC_PR command is out of range.</td> </tr> <tr> <td>0x0211</td> <td>Parameter setting of Type [8] PR is in error.</td> </tr> <tr> <td>0x0213</td> <td>The value written to the SACC_PR command exceeds the setting range of the specific parameter.</td> </tr> <tr> <td>0x0215</td> <td>This parameter is read-only, so the SACC_PR command cannot be written.</td> </tr> <tr> <td>0x0217</td> <td>In the Servo On state, the SACC_PR command cannot be written.</td> </tr> <tr> <td>0x0219</td> <td>This parameter is write-protected, so the SACC_PR command cannot be written. Check if the parameter and data array protection function (P5.097) is enabled.</td> </tr> <tr> <td>0x021B</td> <td>The stack space is insufficient. Calling multiple levels of functions may use up the stack space. Try reducing the number of levels first.</td> </tr> <tr> <td>0x021D</td> <td>Used the division (DIV) command (DIVF, DIVL, DIVW), but the divisor is 0.</td> </tr> <tr> <td>0x0221</td> <td>The mode specified by the argument of the MODE command is undefined.</td> </tr> <tr> <td>0x0223</td> <td>When the servo drive is in the Servo Off or Quick Stop state, some motion command operations are invalid.</td> </tr> <tr> <td>0x022D</td> <td>When the E-Cam is engaged, the PABS command is unavailable.</td> </tr> <tr> <td>0x0231</td> <td>The index value (monitoring variable number) of the LACCL_SV or SACCL_SV command is out of range.</td> </tr> <tr> <td>0x0235</td> <td>The overflow of the absolute position causes the PABS command to be unavailable. Execute the homing procedure.</td> </tr> <tr> <td>0x0239</td> <td>The loop mode specified by the argument of the LOOP_CMD command is undefined.</td> </tr> <tr> <td>0x023F</td> <td>The register storage command accesses the wrong memory space with the pointer.</td> </tr> <tr> <td>0x0245</td> <td>The wait command exceeded the time limit. Use the TIMEOUT command to adjust the maximum waiting time.</td> </tr> <tr> <td>0x0247</td> <td>Called a math function with the index out of range.</td> </tr> <tr> <td>0x0251</td> <td>Argument of the power command is not within the range of 0 - 10.</td> </tr> <tr> <td>0x0255</td> <td>Argument of the object call command is out of range.</td> </tr> <tr> <td>0x0257</td> <td>A non-existing object index is called.</td> </tr> <tr> <td>0x025B</td> <td>Object call error (ID, Version, Size).</td> </tr> <tr> <td>0x025F</td> <td>An error occurs when OD is accessed.</td> </tr> <tr> <td>0x0261</td> <td>P3.005.Y is not set to 1, so the servo drive cannot read / write the Modbus object.</td> </tr> <tr> <td>0x0262</td> <td>When the Modbus object is used, the read / write packet length exceeds the limit.</td> </tr> </tbody> </table>	Error code	Description	0x0203	Task number is out of range when the command for configuring the task is used.	0x0207	The parameter group (grp) value of the LACC_PR or SACC_PR command is out of range.	0x0209	The parameter index (idx) value of the LACC_PR or SACC_PR command is out of range.	0x0211	Parameter setting of Type [8] PR is in error.	0x0213	The value written to the SACC_PR command exceeds the setting range of the specific parameter.	0x0215	This parameter is read-only, so the SACC_PR command cannot be written.	0x0217	In the Servo On state, the SACC_PR command cannot be written.	0x0219	This parameter is write-protected, so the SACC_PR command cannot be written. Check if the parameter and data array protection function (P5.097) is enabled.	0x021B	The stack space is insufficient. Calling multiple levels of functions may use up the stack space. Try reducing the number of levels first.	0x021D	Used the division (DIV) command (DIVF, DIVL, DIVW), but the divisor is 0.	0x0221	The mode specified by the argument of the MODE command is undefined.	0x0223	When the servo drive is in the Servo Off or Quick Stop state, some motion command operations are invalid.	0x022D	When the E-Cam is engaged, the PABS command is unavailable.	0x0231	The index value (monitoring variable number) of the LACCL_SV or SACCL_SV command is out of range.	0x0235	The overflow of the absolute position causes the PABS command to be unavailable. Execute the homing procedure.	0x0239	The loop mode specified by the argument of the LOOP_CMD command is undefined.	0x023F	The register storage command accesses the wrong memory space with the pointer.	0x0245	The wait command exceeded the time limit. Use the TIMEOUT command to adjust the maximum waiting time.	0x0247	Called a math function with the index out of range.	0x0251	Argument of the power command is not within the range of 0 - 10.	0x0255	Argument of the object call command is out of range.	0x0257	A non-existing object index is called.	0x025B	Object call error (ID, Version, Size).	0x025F	An error occurs when OD is accessed.	0x0261	P3.005.Y is not set to 1, so the servo drive cannot read / write the Modbus object.	0x0262	When the Modbus object is used, the read / write packet length exceeds the limit.
Error code	Description																																																						
0x0203	Task number is out of range when the command for configuring the task is used.																																																						
0x0207	The parameter group (grp) value of the LACC_PR or SACC_PR command is out of range.																																																						
0x0209	The parameter index (idx) value of the LACC_PR or SACC_PR command is out of range.																																																						
0x0211	Parameter setting of Type [8] PR is in error.																																																						
0x0213	The value written to the SACC_PR command exceeds the setting range of the specific parameter.																																																						
0x0215	This parameter is read-only, so the SACC_PR command cannot be written.																																																						
0x0217	In the Servo On state, the SACC_PR command cannot be written.																																																						
0x0219	This parameter is write-protected, so the SACC_PR command cannot be written. Check if the parameter and data array protection function (P5.097) is enabled.																																																						
0x021B	The stack space is insufficient. Calling multiple levels of functions may use up the stack space. Try reducing the number of levels first.																																																						
0x021D	Used the division (DIV) command (DIVF, DIVL, DIVW), but the divisor is 0.																																																						
0x0221	The mode specified by the argument of the MODE command is undefined.																																																						
0x0223	When the servo drive is in the Servo Off or Quick Stop state, some motion command operations are invalid.																																																						
0x022D	When the E-Cam is engaged, the PABS command is unavailable.																																																						
0x0231	The index value (monitoring variable number) of the LACCL_SV or SACCL_SV command is out of range.																																																						
0x0235	The overflow of the absolute position causes the PABS command to be unavailable. Execute the homing procedure.																																																						
0x0239	The loop mode specified by the argument of the LOOP_CMD command is undefined.																																																						
0x023F	The register storage command accesses the wrong memory space with the pointer.																																																						
0x0245	The wait command exceeded the time limit. Use the TIMEOUT command to adjust the maximum waiting time.																																																						
0x0247	Called a math function with the index out of range.																																																						
0x0251	Argument of the power command is not within the range of 0 - 10.																																																						
0x0255	Argument of the object call command is out of range.																																																						
0x0257	A non-existing object index is called.																																																						
0x025B	Object call error (ID, Version, Size).																																																						
0x025F	An error occurs when OD is accessed.																																																						
0x0261	P3.005.Y is not set to 1, so the servo drive cannot read / write the Modbus object.																																																						
0x0262	When the Modbus object is used, the read / write packet length exceeds the limit.																																																						
How to clear the alarm?	<p>Cycle power on the servo drive.</p>																																																						

ALF22 Password does not match	
Trigger condition and cause	<p>Condition: the password of the second development platform project does not match that of the servo drive.</p> <p>Cause: the password of the second development platform project does not match that of the servo drive.</p>
Checking method and corrective action	<p>Check if the password of the second development platform and the password of the servo drive are input correctly.</p>
How to clear the alarm?	<ol style="list-style-type: none"> <li>1. You can change the password of the second development platform project with the EzASD software, but you cannot reset the password.</li> <li>2. You can change the servo drive password with the EzASD software. You can also set P2.008 to 10 to reset the servo drive password.</li> </ol> <p>Note that setting P2.008 to 10 not only resets all parameters but also clears the second development platform projects stored in the servo drive.</p>



(This page is intentionally left blank.)

14

# Specifications Appendix

# A

A.1	ASDA-A3 series servo drive .....	A-3
A.1.1	Specifications of the servo drive .....	A-3
A.1.1.1	220V series .....	A-3
A.1.1.2	400V series .....	A-6
A.1.2	Dimensions of the servo drive .....	A-9
A.1.2.1	220V series .....	A-9
A.1.2.2	400V series .....	A-13
A.2	ECM-A3 series servo motor.....	A-15
A.2.1	Specifications of ECM-A3L low inertia series servo motor .....	A-17
A.2.2	Specifications of ECM-A3H high inertia series servo motor.....	A-19
A.2.3	Torque features (T-N curves) of the A3 motors.....	A-21
A.2.4	Overload features.....	A-23
A.2.5	Dimensions of ECM-A3L/A3H series servo motor.....	A-24
A.3	ECM-B3 series servo motor.....	A-25
A.3.1	Specifications of ECM-B3 series servo motor .....	A-27
A.3.1.1	220V series .....	A-27
	Motor frame size: 80 mm and below (low & medium inertia).....	A-27
	Motor frame size: 80 mm and below (high inertia).....	A-29
	Motor frame size: 100 mm (medium inertia).....	A-31
	Motor frame size: 130 mm (medium & high inertia) .....	A-33
	Motor frame size: 180 mm (medium inertia).....	A-35
	Motor frame size: 220 mm (medium inertia).....	A-37
A.3.1.2	400V series .....	A-39
	Motor frame size: 80 mm and below (medium inertia).....	A-39
	Motor frame size: 100 mm (medium inertia).....	A-41
	Motor frame size: 130 mm (medium & high inertia) .....	A-43
	Motor frame size: 180 mm (medium inertia).....	A-45
	Motor frame size: 220 mm (medium inertia).....	A-47
A.3.2	Torque features (T-N curves) of the B3 motors.....	A-49
A.3.2.1	220V series .....	A-49
	Motor frame size: 80 mm and below .....	A-49
	Motor frame size: 100 mm .....	A-50
	Motor frame size: 130 mm .....	A-51
	Motor frame size: 180 mm .....	A-52



- Motor frame size: 220 mm ..... A-53
- A.3.2.2 400V series ..... A-54
  - Motor frame size: 80 mm and below ..... A-54
  - Motor frame size: 100 mm ..... A-54
  - Motor frame size: 130 mm ..... A-55
  - Motor frame size: 180 mm ..... A-56
  - Motor frame size: 220 mm ..... A-57
- A.3.3 Power derating curves of the B3 motors ..... A-58
- A.3.4 Overload features..... A-59
- A.3.5 Dimensions of ECM-B3 series servo motor ..... A-61
  - A.3.5.1 220V series ..... A-61
    - Motor frame size: 80 mm and below, with cables (low & medium & high inertia) ..... A-61
    - Motor frame size: 80 mm and below, with bulkhead connectors (low & medium & high inertia)..... A-62
    - Motor frame size: 100 mm (medium inertia)..... A-63
    - Motor frame size: 130 mm (medium & high inertia) ..... A-64
    - Motor frame size: 180 mm (medium inertia)..... A-65
    - Motor frame size: 220 mm (medium inertia)..... A-66
  - A.3.5.2 400V series ..... A-67
    - Motor frame size: 80 mm and below, with cables (medium inertia)-- A-67
    - Motor frame size: 100 mm (medium inertia)..... A-68
    - Motor frame size: 130 mm (medium & high inertia) ..... A-69
    - Motor frame size: 180 mm (medium inertia)..... A-70
    - Motor frame size: 220 mm (medium inertia)..... A-71

## A.1 ASDA-A3 series servo drive

### A.1.1 Specifications of the servo drive

#### A.1.1.1 220V series

ASDA-A3			100 W	200 W	400 W	750 W	1 kW	1.5 kW	2 kW	3 kW
			01	02	04	07	10	15	20	30
Main circuit	Phase / Voltage		Single- / Three-phase 220 V <sub>AC</sub>						Three-phase 220 V <sub>AC</sub>	
	Permissible voltage		Single- / Three-phase 200 - 230 V <sub>AC</sub> , -15% to +10%						Three-phase 200 - 230 V <sub>AC</sub> , -15% to +10%	
	Input current (3PH) (Arms)		0.81	1.23	1.95	3.8	5.24	5.91	12.3	14.9
	Input current (1PH) (Arms)		1.43	2.19	3.49	7.12	9.93	11.14	-	-
	Inrush current (Arms)		5.78	5.78	5.78	5.78	5.78	5.78	13.10	13.10
Control power	Phase / Voltage		Single-phase 220 V <sub>AC</sub>							
	Permissible voltage		Single-phase 200 - 230 V <sub>AC</sub> , -15% to +10%							
	Input current (Arms)		0.20	0.20	0.20	0.23	0.23	0.23	0.29	0.29
	Inrush current (Arms)		21.83	21.83	21.83	21.83	21.83	21.83	21.83	21.83
Continuous output current (Arms)			0.9	1.55	2.6	5.1	7.3	8.3	13.4	19.4
Max. instantaneous output current (Arms)			3.54	7.07	10.61	21.21	24.75	27	53.03	58.9
Regenerative resistor	Built-in	Resistance (Ohm)	-	-	100	100	100	100	20	20
		Capacity (Watt)	-	-	40	40	40	40	80	80
	External	Min. allowable resistance (Ohm)	60	60	60	60	30	30	15	15
Cooling method			Air convection cooling				Fan cooling			

ASDA-A3			4.5 kW	5.5 kW	7.5 kW	11 kW	15 kW
			45	55	75	1B	1F
Main circuit	Phase / Voltage		Three-phase 220 V <sub>AC</sub>				
	Permissible voltage		Three-phase 200 - 230 V <sub>AC</sub> , -15% to +10%				
	Input current (3PH) (Arms)		19.3	23.8	29	50.3	64.7
	Inrush current (Arms)		13.1	11.79	15.72	35.47	35.47
Control power	Phase / voltage		Single-phase 220 V <sub>AC</sub>				
	Permissible voltage		Single-phase 200 - 230 V <sub>AC</sub> , -15% to +10%				
	Input current (Arms)		0.33	0.51	0.51	0.54	1.38
	Inrush current (Arms)		52.40	39.30	49.13	58.95	65.50
Continuous output current (Arms)			32.5	40	47.5	58.6	72.8
Max. instantaneous output current (Arms)			70.71	95.6	106.1	120	192.4
Regenerative resistor	Built-in	Resistance (Ohm)	20	-	-	-	-
		Capacity (Watt)	100	-	-	-	-
	External	Min. allowable resistance (Ohm)	10	8	8	6	5
Cooling method			Fan cooling				



Note: the input current is the actual value measured when the servo drive is under the rated output condition with a power supply at 220 V<sub>AC</sub>.

#### Specification table

A

A

Item		Specification	
Servo drive resolution		24-bit (16777216 p/rev)	
Main circuit control		SVPWM control	
Tuning mode		Manual / Auto	
Position control mode	Pulse type	Pulse + symbol, CCW pulse + CW pulse, A phase + B phase	
	Max. input pulse frequency	Pulse + symbol: 4 Mpps CCW pulse + CW pulse: 4 Mpps A phase + B phase: single-phase 2 Mpps Open collector: 200 Kpps	
	Command source	External pulse / Register	
	Smoothing method	Low-pass filter; S-curve filter; moving filter	
	E-Gear ratio	E-Gear ratio: N/M times; $1 \leq N/M \leq 262144$ N: 1 - 536870911 / M: 1 - 2147483647	
	Torque limit	Parameter settings	
	Feedforward compensation	Parameter settings	
Speed control mode	Analog command input	Voltage range	-10 to +10 V <sub>DC</sub>
		Resolution	15-bit
		Input impedance	1 MΩ
		Time constant	25 μs
	Speed control range*1	1 : 6000	
	Command source	External analog command / Register	
	Smoothing method	Low-pass and S-curve filters	
	Torque limit	Parameter settings / Analog input	
	Bandwidth	Maximum 3.1 kHz	
	Speed calibration ratio*2	±0.01% at 0% to 100% load fluctuation	
		±0.01% at ±10% power fluctuation	
±0.01% at 0°C to 50°C (32°F to 122°F) ambient temperature fluctuation			
Torque control mode	Analog command input	Voltage range	-10 to +10 V <sub>DC</sub>
		Input impedance	1 MΩ
		Time constant	25 μs
	Command source	External analog command / Register	
	Smoothing method	Low-pass filter	
	Speed limit	Parameter settings / Analog input	
Analog monitor output		Monitor signal can be set by parameters (voltage output range: ±8V); resolution: 10-bit	
Digital input		-L and -M models: 10 DI points; -F and -E models: 7 DI points. Refer to Chapter 8 for the function settings.	
Digital output		-L and -M models: 6 DO points; -F and -E models: 4 DO points. Refer to Chapter 8 for the function settings.	

Item		Specification
Protection function		Overcurrent, Overvoltage, Undervoltage, Overheat, Regeneration error, Overload, Excessive speed deviation, Excessive position deviation, Encoder error, Calibration error, Emergency stop, Positive / negative limit error, Serial communication error, RST power error, Serial communication timeout, Short-circuit protection for terminals U, V, W.
Communication interface		RS-485 / USB / CANopen / DMCNET / EtherCAT
Environment	Installation site	Indoors (avoid direct sunlight), no corrosive vapor (avoid fumes, flammable gases, and dust)
	Altitude	Less than 2,000 m above sea level
	Atmospheric pressure	86 kPa - 106 kPa
	Operating temperature	0°C to 55°C (32°F to 131°F) (If the operating temperature is above 45°C (113°F), forced cooling is required)
	Storage temperature	-20°C to +65°C (14°F to 176°F)
	Humidity	Under 0 - 90% RH (non-condensing)
	Vibrating	10 Hz - 57 Hz: 0.075 mm amplitude; 58 Hz - 150 Hz: 1G
	Pollution degree	Degree 2
	IP rating	IP20 <sup>*4</sup>
	Power system	TN system / TT system
	Approvals <sup>*5</sup>	IEC/EN/UL 61800-5-1  

## Note:

1. Within the rated load, the speed ratio is: the minimum speed (smooth operation) / rated speed.
2. Within the rated speed, the speed calibration ratio is: (rotational speed with no load - rotational speed with full load) / rated speed.
3. Use a single-phase three-wire power system for the single-phase power model.
4. The terminal blocks are not IP20 rated.
5. Please visit [Delta website](#) to download the certificates.
6. TUV Functional Safety application in progress.
7. This equipment does not have functions of thermal memory for shutdown, thermal memory for loss of power, and speed sensitivity in accordance with EN 61800-5-1:2007/A1:2017.
8. To meet the functional safety requirement, install the servo drive in the cabinet with a rating of IP54 or higher.

A

A

**A.1.1.2 400V series**

ASDA-A3			400 W	750 W	1 kW	1.5 kW	2 kW	3 kW
			0.4	0.75	1	1.5	2	3
Main circuit	Phase / Voltage		Three-phase 400 V <sub>AC</sub>					
	Permissible voltage		Three-phase 380 - 480 V <sub>AC</sub> , -10% to +10%					
	Input current (3PH) (Arms)* <sup>1</sup>		0.9	1.8	2.4	3.4	4.5	6.3
	Inrush current (Arms)		5.6	5.6	5.6	5.6	12.5	12.5
Control power	Voltage* <sup>2</sup>		24 V <sub>DC</sub>					
	Permissible voltage		24 V <sub>DC</sub> , -10% to +10%					
	Input current (Arms)		1.7	1.7	1.7	1.7	2.1	2.1
	Inrush current (Arms)		5	5	5	5	4.8	4.8
Continuous output current (Arms)			1.60	3.12	3.52	5.06	6.60	9.11
Max. instantaneous output current (Arms)			5.40	9.70	10.54	16.35	19.88	29.45
Regenerative resistor	Built-in	Resistance (Ohm)	80	80	80	80	-	-
		Capacity (Watt)	60	60	60	60	-	-
	External	Min. allowable resistance (Ohm)	80	60	60	40	40	30
Cooling method			Fan cooling					

ASDA-A3			4.5 kW	5.5 kW	7.5 kW	11 kW	15 kW	
			4.5	5.5	7.5	11	15	
Main circuit	Phase / Voltage		Three-phase 400 V <sub>AC</sub>					
	Permissible voltage		Three-phase 380 - 480 V <sub>AC</sub> , -10% to +10%					
	Input current (3PH) (Arms)* <sup>1</sup>		8.7	10.7	14.1	21.8	29.6	
	Inrush current (Arms)		12.5	12.5	12.5	12.5	12.5	
Control power	Voltage* <sup>2</sup>		24 V <sub>DC</sub>					
	Permissible voltage		24 V <sub>DC</sub> , -10% to +10%					
	Input current (Arms)		2.1	2.1	2.5	3	3	
	Inrush current (Arms)		5.5	5.5	5.5	6	6	
Continuous output current (Arms)			13.30	15.34	22.40	27.30	31.00	
Max. instantaneous output current (Arms)			35.35	49.29	56.68	68.25	80.20	
Regenerative resistor	Built-in	Resistance (Ohm)	-	-	-	-	-	
		Capacity (Watt)	-	-	-	-	-	
	External	Min. allowable resistance (Ohm)	25	25	15	15	15	
Cooling method			Fan cooling					

Note:

1. The input current for the main circuit is the actual value measured when the servo drive is under the rated output condition with a power supply at 480 V<sub>AC</sub>.
2. Use SELV power supply for the 24V power of control power.



Specification table

Item		Specification	
Servo drive resolution		24-bit (16777216 p/rev)	
Main circuit control		SVPWM control	
Tuning mode		Manual / Auto	
Position control mode	Pulse type	Pulse + symbol, CCW pulse + CW pulse, A phase + B phase	
	Max. input pulse frequency	Pulse + symbol: 4 Mpps CCW pulse + CW pulse: 4 Mpps A phase + B phase: single-phase 2 Mpps Open collector: 200 Kpps	
	Command source	External pulse / Register	
	Smoothing method	Low-pass filter; S-curve filter; moving filter	
	E-Gear ratio	E-Gear ratio: N/M times; $1 \leq N/M \leq 262144$ N: 1 - 536870911 / M: 1 - 2147483647	
	Torque limit	Parameter settings	
	Feedforward compensation	Parameter settings	
Speed control mode	Analog command input	Voltage range	-10 to +10 V <sub>DC</sub>
		Resolution	15-bit
		Input impedance	1 M $\Omega$
		Time constant	25 $\mu$ s
	Speed control range <sup>*1</sup>	1 : 6000	
	Command source	External analog command / Register	
	Smoothing method	Low-pass and S-curve filters	
	Torque limit	Parameter settings / Analog input	
	Bandwidth	Maximum 3.1 kHz	
	Speed calibration ratio <sup>*2</sup>	$\pm 0.01\%$ at 0% to 100% load fluctuation	
		$\pm 0.01\%$ at $\pm 10\%$ power fluctuation	
$\pm 0.01\%$ at 0°C to 50°C (32°F to 122°F) ambient temperature fluctuation			
Torque control mode	Analog command input	Voltage range	-10 to +10 V <sub>DC</sub>
		Input impedance	1 M $\Omega$
		Time constant	25 $\mu$ s
	Command source	External analog command / Register	
	Smoothing method	Low-pass filter	
	Speed limit	Parameter settings / Analog input	
Analog monitor output	Monitor signal can be set by parameters (voltage output range: $\pm 8$ V); resolution: 10-bit		
Digital input	-L and -M models: 10 DI points; -F and -E models: 7 DI points. Refer to Chapter 8 for the function settings.		
Digital output	-L and -M models: 6 DO points; -F and -E models: 4 DO points. Refer to Chapter 8 for the function settings.		

A



A

Item		Specification
Protection function		Overcurrent, Overvoltage, Undervoltage, Overheat, Regeneration error, Overload, Excessive speed deviation, Excessive position deviation, Encoder error, Calibration error, Emergency stop, Positive / negative limit error, Serial communication error, RST power error, Serial communication timeout, Short-circuit protection for terminals U, V, W.
Communication interface		RS-485 / USB / CANopen / DMCNET / EtherCAT
Environment	Installation site	Indoors (avoid direct sunlight), no corrosive vapor (avoid fumes, flammable gases, and dust)
	Altitude	Less than 2,000 m above sea level
	Atmospheric pressure	86 kPa - 106 kPa
	Operating temperature	0°C to 55°C (32°F to 131°F) (When operating the 3 kW model at 50°C to 55°C (122°F to 131°F), decrease the rated load to 80%.) If the temperature is over 45°C (113°F), place the product in a well-ventilated environment.
	Storage temperature	-20°C to +65°C (-4°F to 176°F)
	Humidity	Under 0 - 90% RH (non-condensing)
	Vibrating	10 Hz - 57 Hz: 0.075 mm amplitude; 58 Hz - 150 Hz: 1G
	Pollution degree	Degree 2
	IP rating	IP20 <sup>*3</sup>
	Power system	TN system / TT system
	Approvals <sup>*4</sup>	IEC/EN/UL 61800-5-1   

Note:

1. Within the rated load, the speed ratio is: the minimum speed (smooth operation) / rated speed.
2. Within the rated speed, the speed calibration ratio is: (rotational speed with no load - rotational speed with full load) / rated speed.
3. The terminal blocks are not IP20 rated.
4. Please visit [Delta website](#) to download the certificates.
5. This equipment does not have functions of thermal memory for shutdown, thermal memory for loss of power, and speed sensitivity in accordance with EN 61800-5-1:2007/A1:2017.
6. To meet the functional safety requirement, install the servo drive in the cabinet with a rating of IP54 or higher.

### A.1.2 Dimensions of the servo drive

#### A.1.2.1 220V series

##### 100 W / 200 W

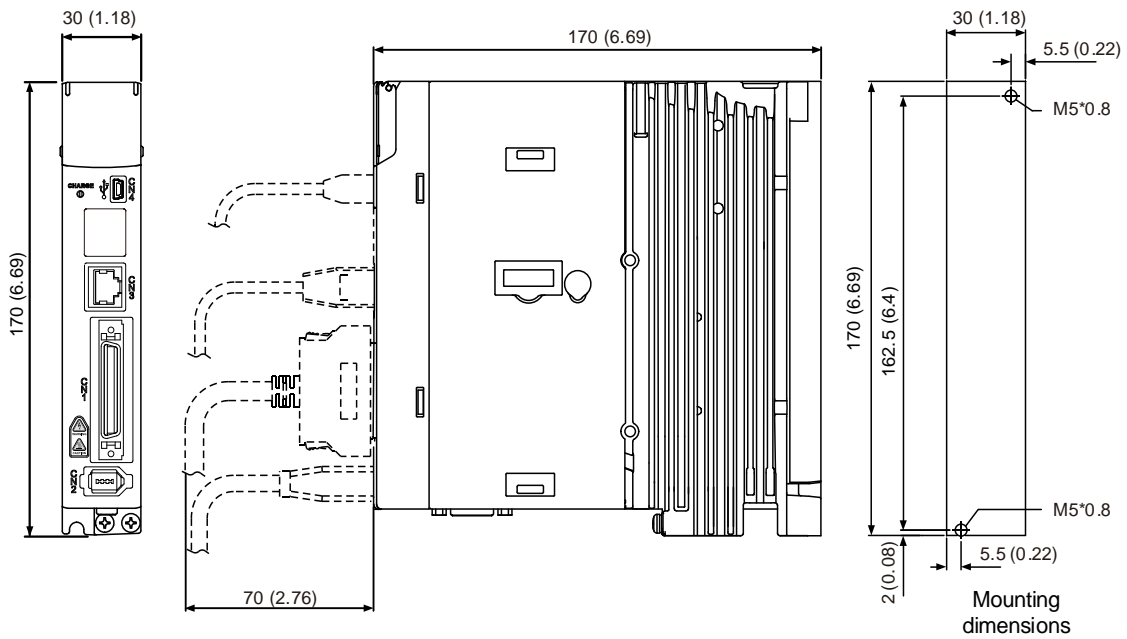

- ⊕ ⊖ SCREW: M4x0.7
- ⊗ ⊗ Mounting screw torque: 12 - 14 (kgf-cm)

Unit: mm (inch)

Weight	0.84 kg (1.85 lb)
--------	-------------------

##### 400 W

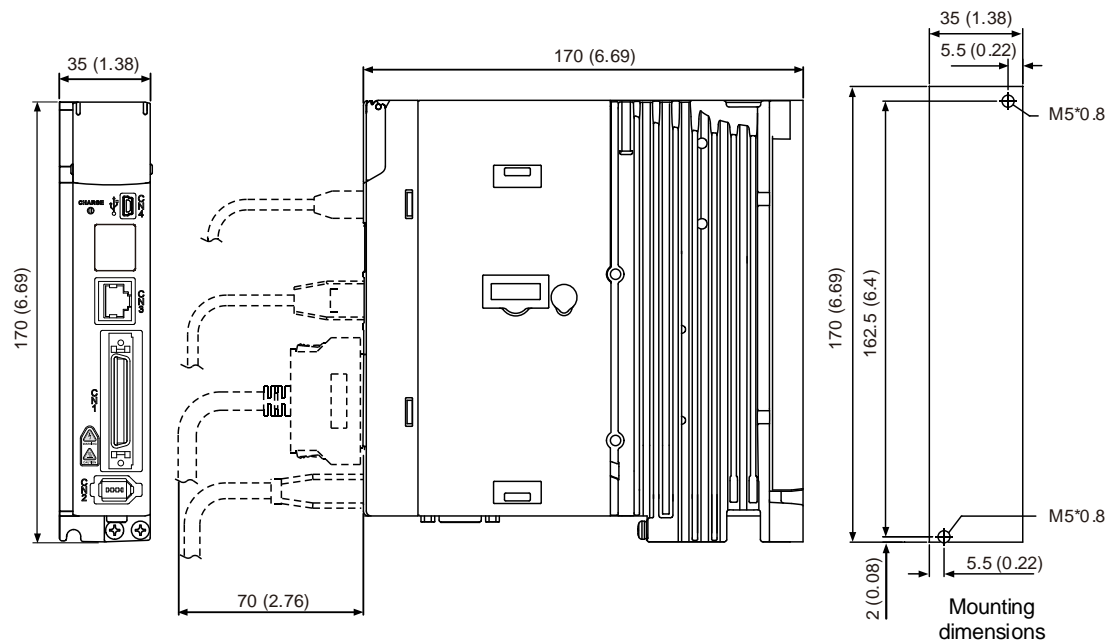

- ⊕ ⊖ SCREW: M4x0.7
- ⊗ ⊗ Mounting screw torque: 12 - 14 (kgf-cm)

Unit: mm (inch)

Weight	0.92 kg (2.03 lb)
--------	-------------------

A

750 W / 1 kW / 1.5 kW

A

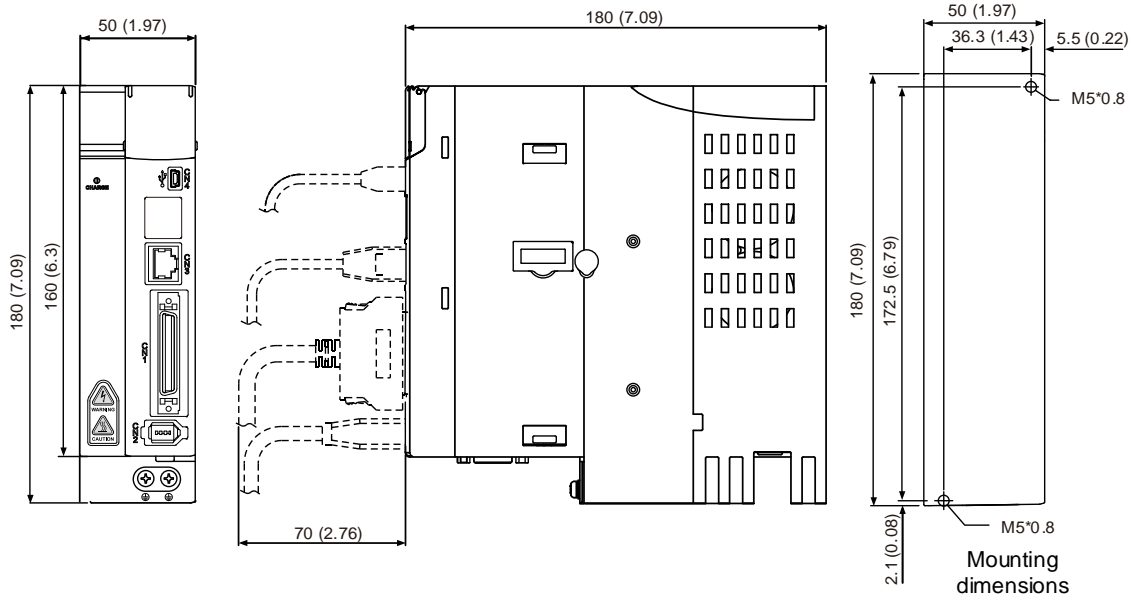

- ⊕ ⊖ SCREW: M4x0.7
- ⊗ ⊙ Mounting screw torque: 12 - 14 (kgf-cm)

Unit: mm (inch)

Weight	1.3 kg (2.87 lb)
--------	------------------

2 kW / 3 kW

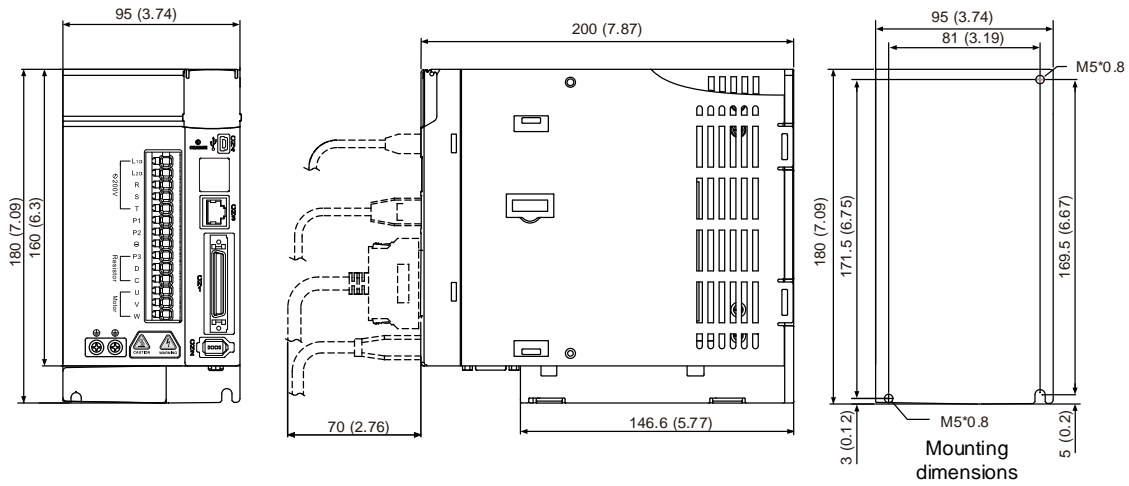

- ⊕ ⊖ SCREW: M4x0.7
- ⊗ ⊙ Mounting screw torque: 12 - 14 (kgf-cm)

Unit: mm (inch)

Weight	2.2 kg (4.85 lb)
--------	------------------

**4.5 kW**

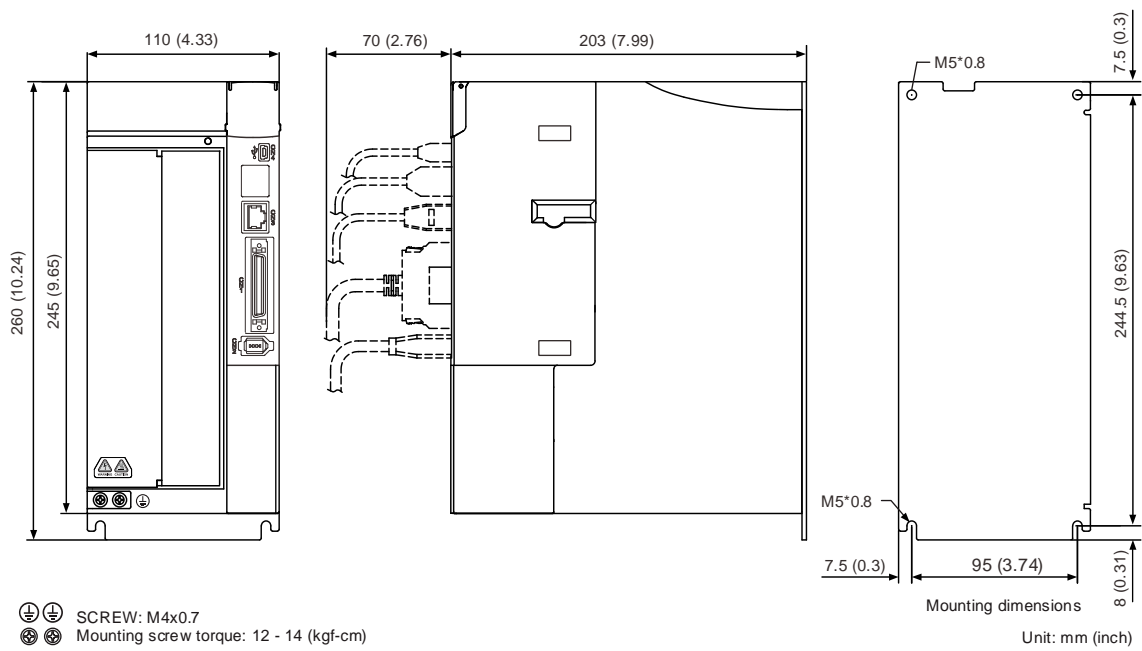

Weight	5.0 kg (11.02 lb)
--------	-------------------

**5.5 / 7.5 kW**

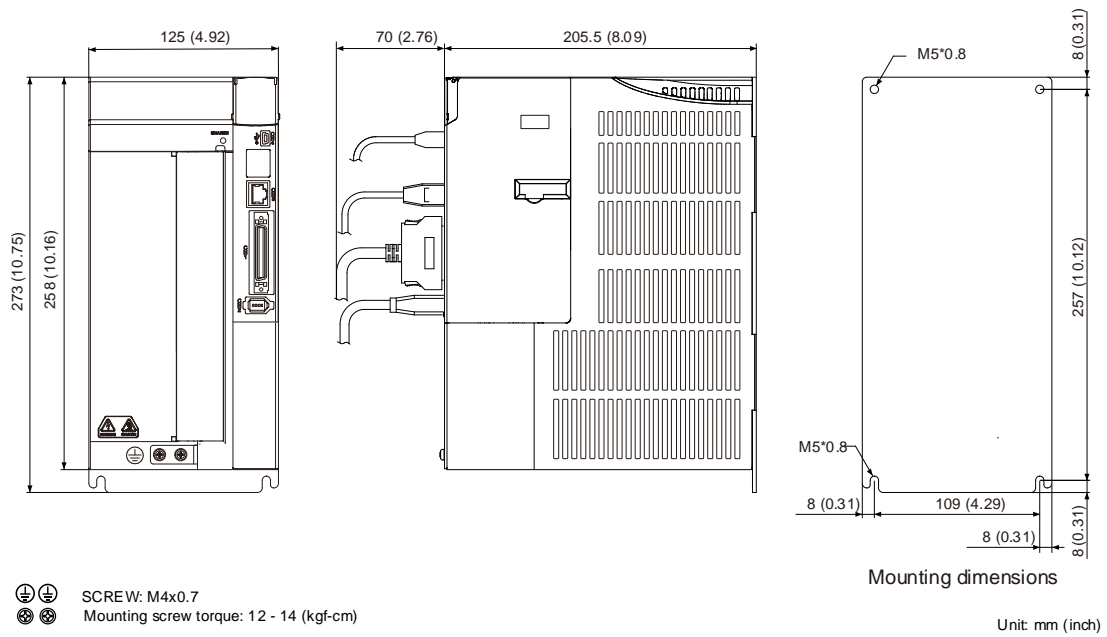

Weight	5.5 kW	4.7 kg (10.36 lb)
	7.5 kW	5.3 kg (11.68 lb)

A

11 kW

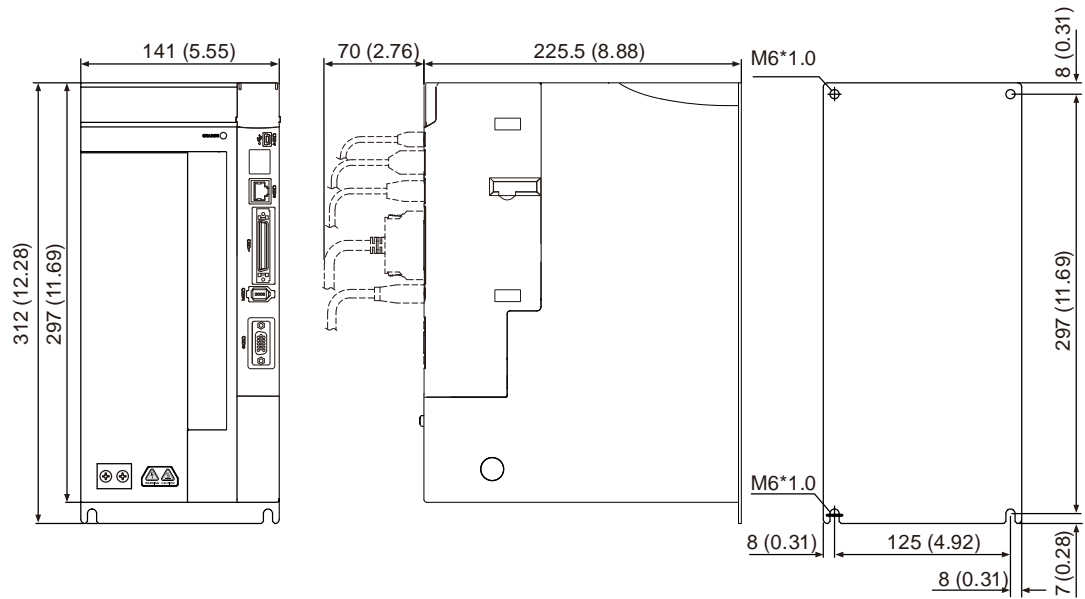

- ⊕ ⊖ SCREW: M4x0.7
- ⊗ ⊗ Mounting screw torque: 12 - 14 (kgf-cm)

Mounting dimensions

Unit: mm (inch)

Weight	7.5 kg (16.53 lb)
--------	-------------------

15 kW

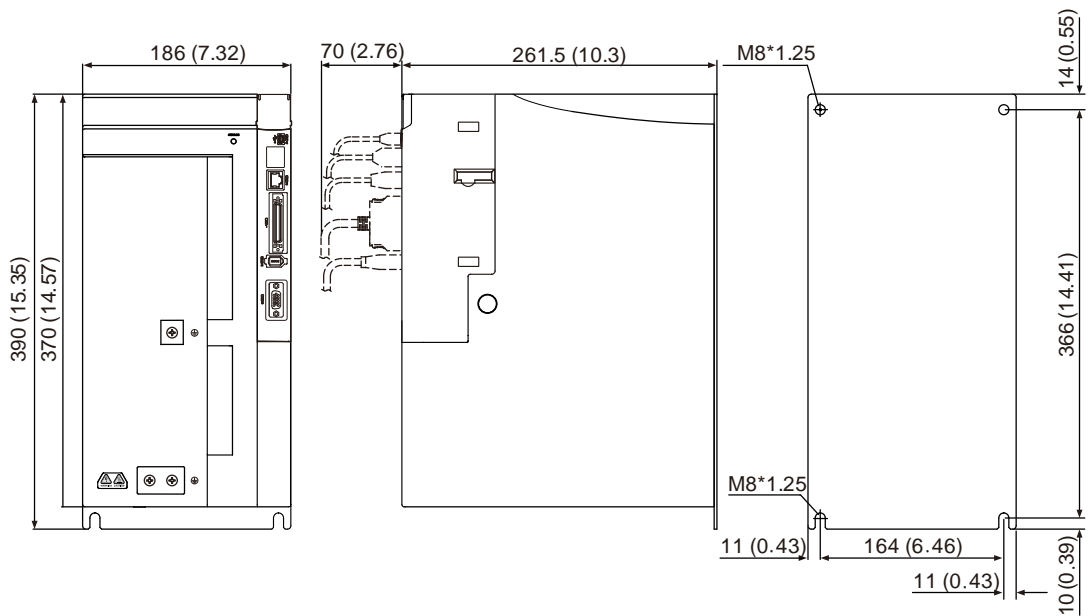

- ⊕ ⊖ SCREW: M5x0.8
- ⊗ ⊗ Mounting screw torque: 20 (kgf-cm)

Mounting dimensions

Unit: mm (inch)

Weight	13.5 kg (29.76 lb)
--------	--------------------

Note: dimensions and weights of the servo drive may be updated without prior notice.

**A.1.2.2 400V series**

**400 W / 750 W / 1 kW / 1.5 kW**

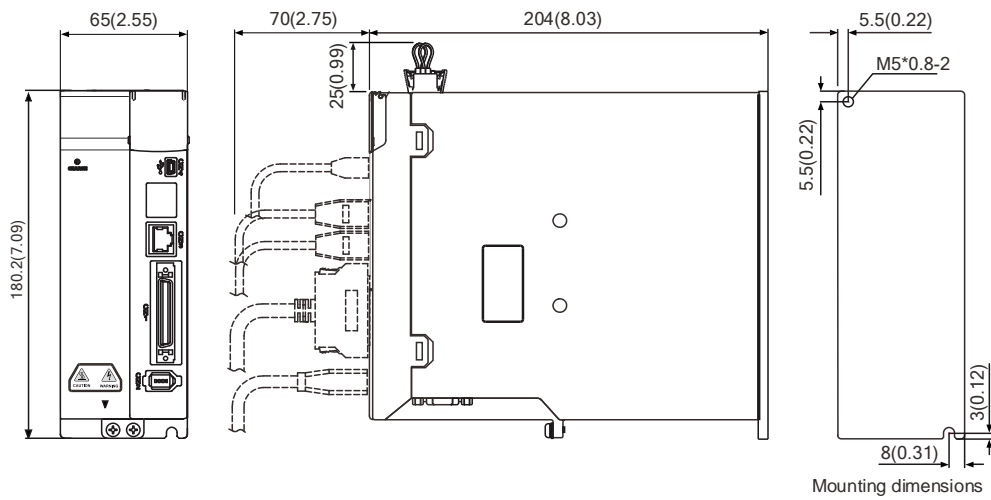

- ⊕ ⊖ SCREW: M4x0.7
- ⊗ ⊙ Mounting screw torque: 12 - 14 (kgf-cm)

Unit: mm (inch)

Weight	1.8 kg (3.97 lb)
--------	------------------

**2 kW / 3 kW / 4.5 kW / 5.5 kW**

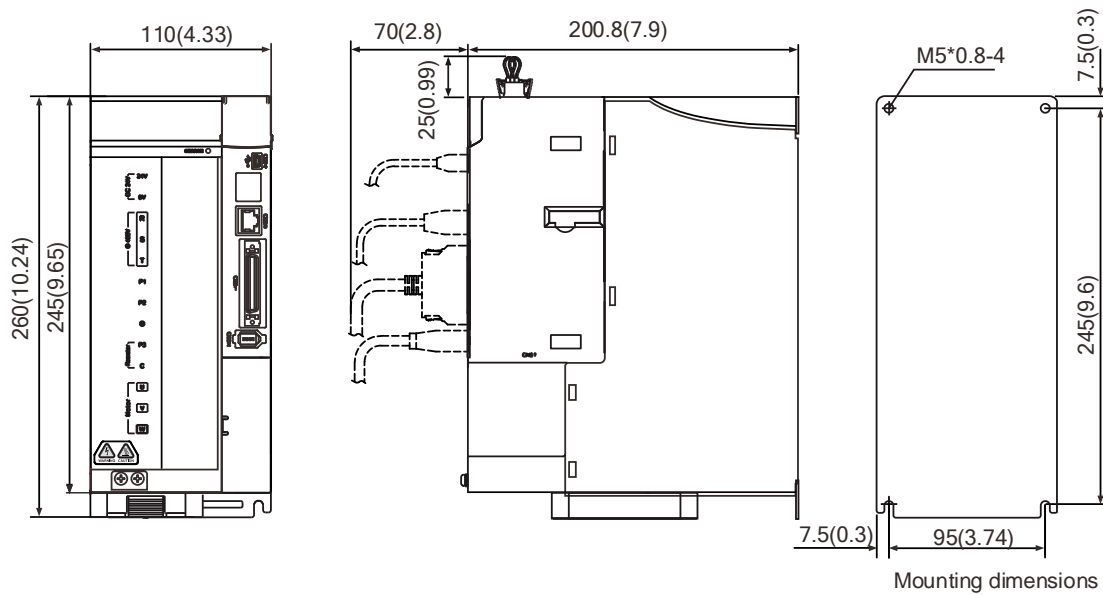

- ⊕ ⊖ SCREW: M4x0.7
- ⊗ ⊙ Mounting screw torque: 12 - 14 (kgf-cm)

Unit: mm (inch)

Weight	2 kW / 3 kW	3.45 kg (7.61 lb)
	4.5 kW / 5.5 kW	4 kg (8.82 lb)

A

7.5 kW

A

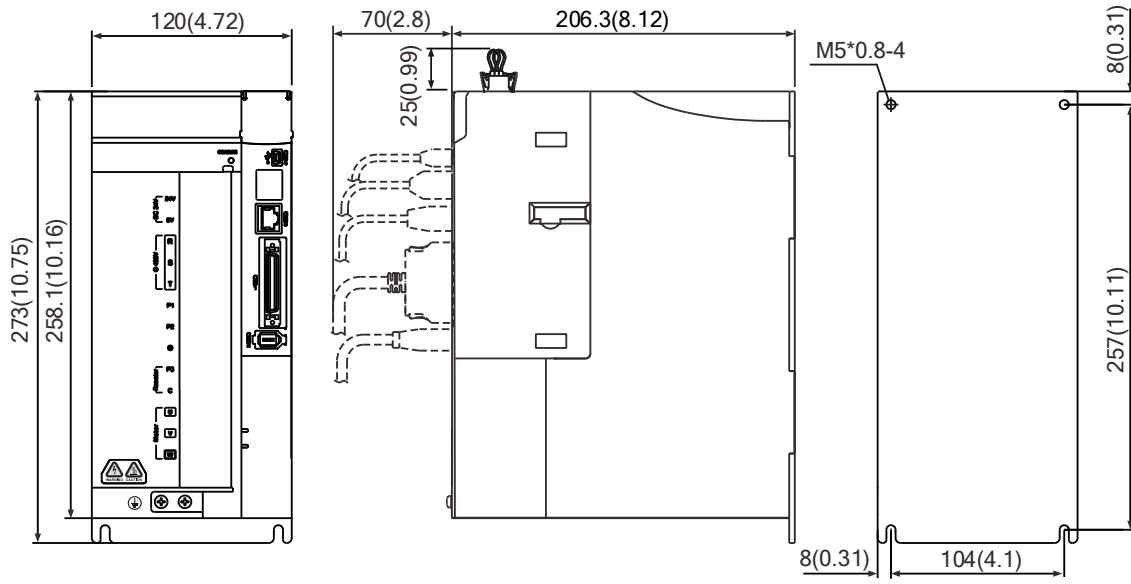

Mounting dimensions

- ⊕ ⊖ SCREW: M4x0.7
- ⊗ ⊗ Mounting screw torque: 12 - 14 (kgf-cm)

Unit: mm (inch)

Weight	5.5 kg (12.13 lb)
--------	-------------------

11 kW / 15 kW

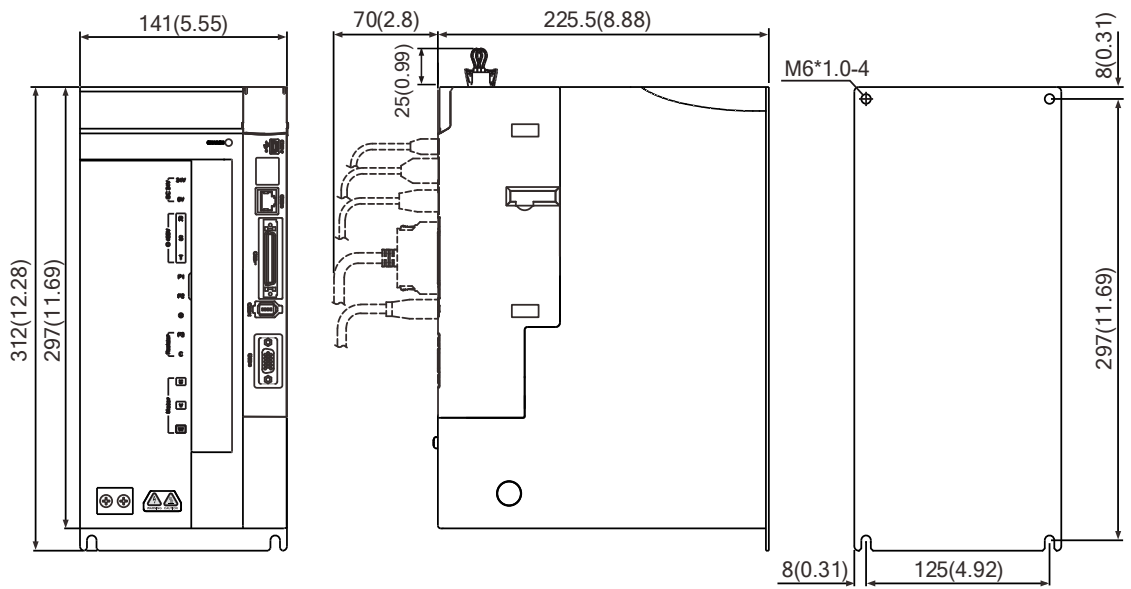

Mounting dimensions

- ⊕ ⊖ SCREW: M4x0.7
- ⊗ ⊗ Mounting screw torque: 12 - 14 (kgf-cm)

Unit: mm (inch)

Weight	7.5 kg (16.53 lb)
--------	-------------------

Note: dimensions and weights of the servo drive may be updated without prior notice.

## A.2 ECM-A3 series servo motor

### ECM-A3 series servo motor model explanation

$$\frac{\text{ECM}}{(1)} - \frac{\text{A}}{(2)} \frac{\text{3}}{(3)} \frac{\text{H}}{(4)} - \frac{\text{C}}{(5)} \frac{\text{Y}}{(6)} \frac{\text{06}}{(7)} \frac{\text{04}}{(8)} \frac{\text{R}}{(9)} \frac{\text{S}}{(10)} \frac{\text{1}}{(11)}$$

# A

(1) Product name

ECM: electronically commutated motor

(2) Servo type

A: high-precision servo motor

(3) Series

3: A3 series

(4) Inertia

H: high inertia

L: low inertia

(5) Rated voltage and speed

C: 220V and 3,000 rpm

(6) Encoder type

Y: 24-bit absolute optical encoder  
(resolution of single turn: 24-bit; number of revolutions: 16-bit)

1: 24-bit incremental optical encoder (single-turn absolute)

A: 24-bit absolute optical encoder  
(resolution of single turn: 24-bit; number of revolutions: 16-bit)

2: 24-bit incremental optical encoder (single-turn absolute)

Note: number of revolutions means the maximum number of turns the encoder can record.

(7) Motor frame size

04: 40 mm

06: 60 mm

08: 80 mm

(8) Rated power output

Code	Specification	Code	Specification
0F	50 W	04	400 W
01	100 W	07	750 W
02	200 W	-	-



A

(9) Shaft type and oil seal

	w/o brake w/o oil seal	with brake w/o oil seal	w/o brake with oil seal	with brake with oil seal
Round shaft (with fixed screw holes)	-	-	C	D
Keyway (with fixed screw holes)	P*	Q*	R	S

Note: \* indicates this model type is coming soon.

(10) Shaft diameter and connector type

S: standard shaft diameter and standard connectors

7: special shaft diameter (14 mm)\* and standard connectors

J: standard shaft diameter and CHOGORI (IP67) connectors

K: special shaft diameter (14 mm)\* and CHOGORI (IP67) connectors

Note: special shaft diameter is available for F80 400 W models.

(11) Special code

1: standard products

Z: special code of C<sup>2</sup>0807<sup>3</sup>S<sup>5</sup>. Refer to the note in Section A.2.5.

## A.2.1 Specifications of ECM-A3L low inertia series servo motor

ECM-A3L-	C□040F	C□0401	C□0602	C□0604	C□0804	C□0807	
Rated power (kW)	0.05	0.1	0.2	0.4	0.4	0.75	
Rated torque (N·m) <sup>*1</sup>	0.159	0.32	0.64	1.27	1.27	2.39	
Max. torque (N·m)	0.557	1.12	2.24	4.45	4.44	8.36	
Rated speed (rpm)	3000						
Max. speed (rpm)	6000						
Rated current (Arms)	0.66	0.9	1.45	2.65	2.6	5.1	
Max. instantaneous current (Arms)	2.82	3.88	6.2	10.1	10.6	20.6	
Change of rated power (kW/s)	w/o brake	11	25.6	45.5	107.5	45.8	102.2
	with brake	9.9	24	34.1	89.6	39.5	93
Rotor inertia (× 10 <sup>-4</sup> kg·m <sup>2</sup> )	w/o brake	0.0229	0.04	0.09	0.15	0.352	0.559
	with brake	0.0255	0.0426	0.12	0.18	0.408	0.614
Mechanical time constant (ms)	w/o brake	1.28	0.838	0.64	0.41	0.68	0.44
	with brake	1.44	0.892	0.85	0.5	0.78	0.48
Torque constant-KT (N·m/Arms)	0.241	0.356	0.441	0.479	0.488	0.469	
Voltage constant-KE (mVrms/rpm)	9.28	13.3	16.4	18	17.9	17	
Armature resistance (Ohm)	12.1	9.47	4.9	2.27	1.6	0.6	
Armature inductance (mH)	18.6	16.2	18.52	10.27	10.6	4.6	
Electrical time constant (ms)	1.54	1.71	3.78	4.52	6.63	7.67	
Weight (kg)	w/o brake	0.38	0.5	1.1	1.4	2.05	2.8
	with brake	0.68	0.8	1.6	1.9	2.85	3.6
Max. radial load (N)	78	78	245	245	392	392	
Max. axial load (N)	54	54	74	74	147	147	
Brake operating voltage	24 V <sub>DC</sub> ± 10%						
Brake power consumption (W) (at 20°C (68°F))	6.1	6.1	7.2	7.2	8	8	
Brake holding torque [N·m (Min)] <sup>*2</sup>	0.32	0.32	1.3	1.3	2.5	2.5	
Brake release time [ms (Max)]	20	20	20	20	20	20	
Brake pull-in time [ms (Max)]	35	35	50	50	60	60	
Derating rate with oil seal (%)	20	10	10	5	5	5	
Insulation class	Class A (UL), Class B (CE)						
Insulation resistance	100 MΩ min. (at 500 V <sub>DC</sub> )						
Insulation strength	1.8 kV <sub>AC</sub> , 1 sec						
Vibration grade	V15						
Ambient temperature	0°C to 40°C (32°F to 104°F)						
Storage temperature	-10°C to +80°C (14°F to 176°F)						
Ambient and storage humidity	20 - 90% RH (non-condensing)						
Vibration capacity	2.5 G						
IP rating	IP67 (for models using waterproof connectors and shaft seals or oil seals)						
Approvals							

A

Note:

1. The rated torque is the continuous permissible torque when the servo motor mounted with the heat sink of the following dimensions is operating in a temperature range of 0°C and 40°C (32°F and 104°F).

F40, F60, and F80: 250 mm x 250 mm x 6 mm

Material: aluminum

2. The built-in servo motor brake is only for keeping the object in a stopped state. Do not use it for deceleration or as a dynamic brake.

A

## A.2.2 Specifications of ECM-A3H high inertia series servo motor

ECM-A3H-	C□040F	C□0401	C□0602	C□0604	C□0804	C□0807	
Rated power (kW)	0.05	0.1	0.2	0.4	0.4	0.75	
Rated torque (N·m) <sup>*1</sup>	0.159	0.32	0.64	1.27	1.27	2.39	
Max. torque (N·m)	0.557	1.12	2.24	4.45	4.44	8.36	
Rated speed (rpm)	3000						
Max. speed (rpm)	6000						
Rated current (Arms)	0.64	0.9	1.45	2.65	2.6	4.61	
Max. instantaneous current (Arms)	2.59	3.64	5.3	9.8	9.32	16.4	
Change of rated power (kW/s)	w/o brake	5.56	13.6	16.4	35.8	17.5	37.8
	with brake	4.89	12.5	14.6	33.6	15.07	34.41
Rotor inertia (× 10 <sup>-4</sup> kg·m <sup>2</sup> )	w/o brake	0.0455	0.0754	0.25	0.45	0.92	1.51
	with brake	0.0517	0.0816	0.28	0.48	1.07	1.66
Mechanical time constant (ms)	w/o brake	2.52	1.43	1.38	0.96	1.32	0.93
	with brake	2.86	1.55	1.54	1.02	1.54	1.02
Torque constant-KT (N·m/Arms)	0.248	0.356	0.441	0.479	0.49	0.52	
Voltage constant-KE (mVrms/rpm)	9.54	12.9	16.4	17.2	17.9	18.7	
Armature resistance (Ohm)	12.5	8.34	3.8	1.68	1.19	0.57	
Armature inductance (mH)	13.34	11	8.15	4.03	4.2	2.2	
Electrical time constant (ms)	1.07	1.32	2.14	2.40	3.53	3.86	
Weight (kg)	w/o brake	0.38	0.5	1.1	1.4	2.05	2.8
	with brake	0.68	0.8	1.6	1.9	2.85	3.6
Max. radial load (N)	78	78	245	245	392	392	
Max. axial load (N)	54	54	74	74	147	147	
Brake operating voltage	24 V <sub>DC</sub> ± 10%						
Brake power consumption (W) (at 20°C (68°F))	6.1	6.1	7.2	7.2	8	8	
Brake holding torque [N·m (Min)] <sup>*2</sup>	0.32	0.32	1.3	1.3	2.5	2.5	
Brake release time [ms (Max)]	20	20	20	20	20	20	
Brake pull-in time [ms (Max)]	35	35	50	50	60	60	
Derating rate with oil seal (%)	20	10	10	5	5	5	
Insulation class	Class A (UL), Class B (CE)						
Insulation resistance	100 MΩ min. (at 500 V <sub>DC</sub> )						
Insulation strength	1.8 kV <sub>AC</sub> , 1 sec						
Vibration grade	V15						
Operating temperature	0°C to 40°C (32°F to 104°F)						
Storage temperature	-10°C to +80°C (14°F to 176°F)						
Operating and storage humidity	20 - 90% RH (non-condensing)						
Vibration capacity	2.5 G						
IP rating	IP67 (for models using waterproof connectors and shaft seals or oil seals)						
Approvals							

Note:

1. The rated torque is the continuous permissible torque when the servo motor mounted with the heat sink of the following dimensions is operating in a temperature range of 0°C and 40°C (32°F and 104°F).

F40, F60, and F80: 250 mm x 250 mm x 6 mm

Material: aluminum

2. The built-in servo motor brake is only for keeping the object in a stopped state. Do not use it for deceleration or as a dynamic brake.

A

### A.2.3 Torque features (T-N curves) of the A3 motors

A

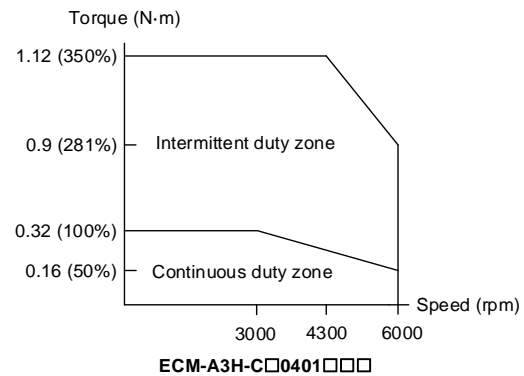
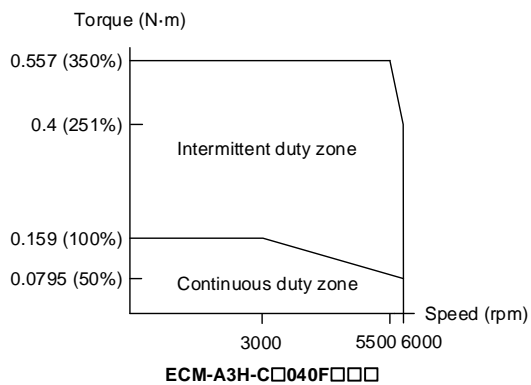
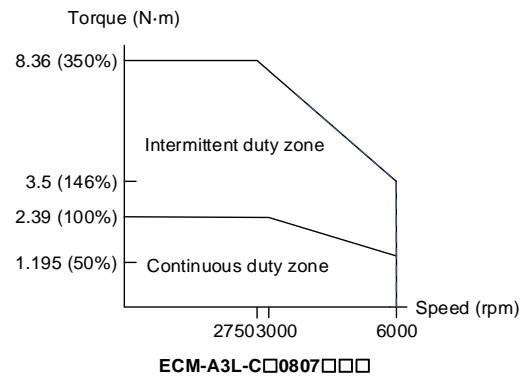
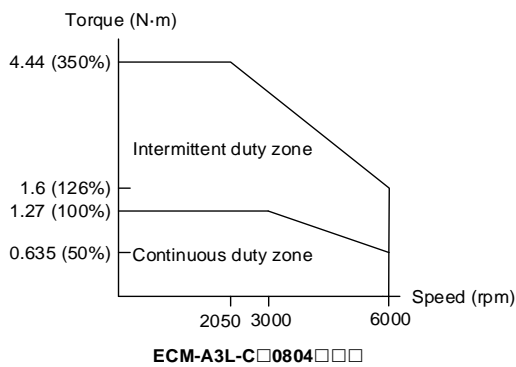
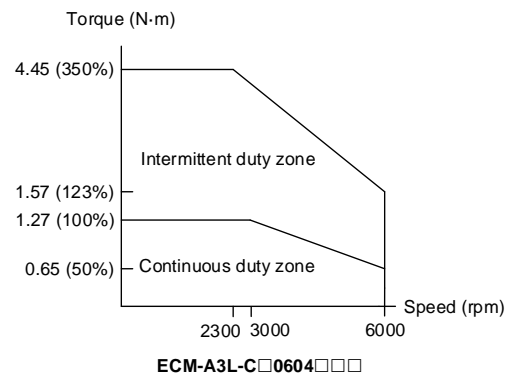
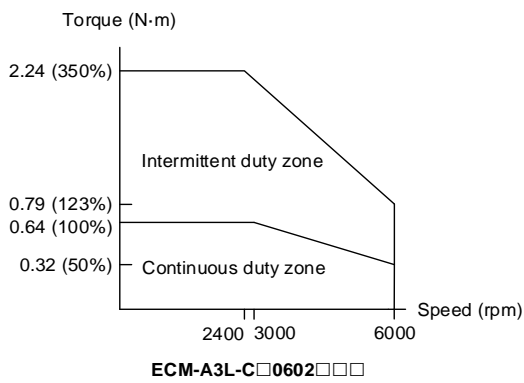
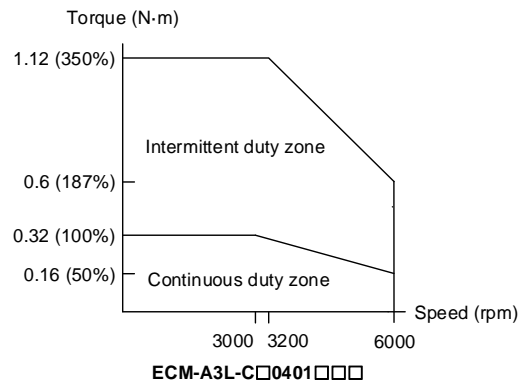
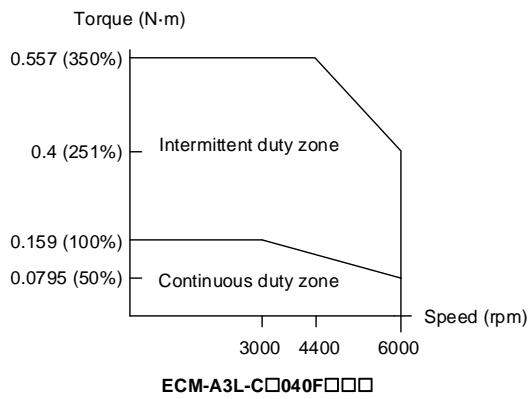

A

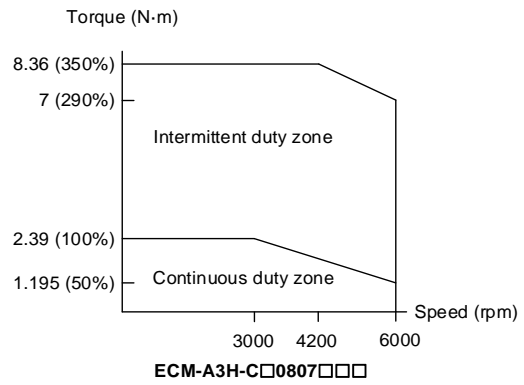
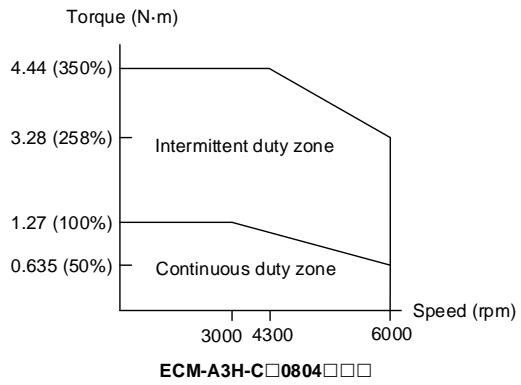
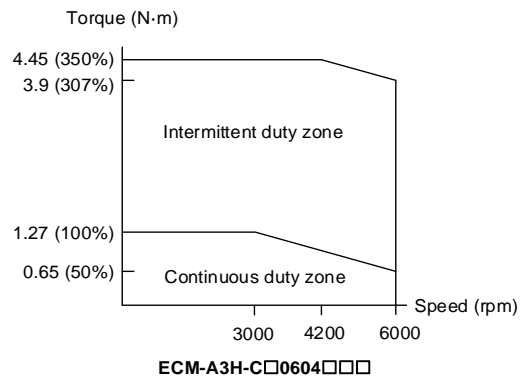
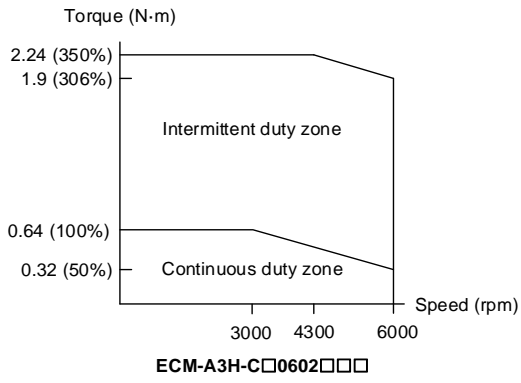

## A.2.4 Overload features

### Definition of overload protection

The overload protection prevents the motor from overheating.



### Causes of overload

1. The motor's operating torque exceeds the rated range and the operating time is too long.
2. The inertia ratio is too high and the motor frequently accelerates and decelerates.
3. Incorrect wiring of the power and encoder cables.
4. Incorrect servo gain setting causes resonance in the motor.
5. A motor with a built-in brake operates without the brake released.

### Graph of load and operating time

Low inertia (ECM-A3L series), high inertia (ECM-A3H series)

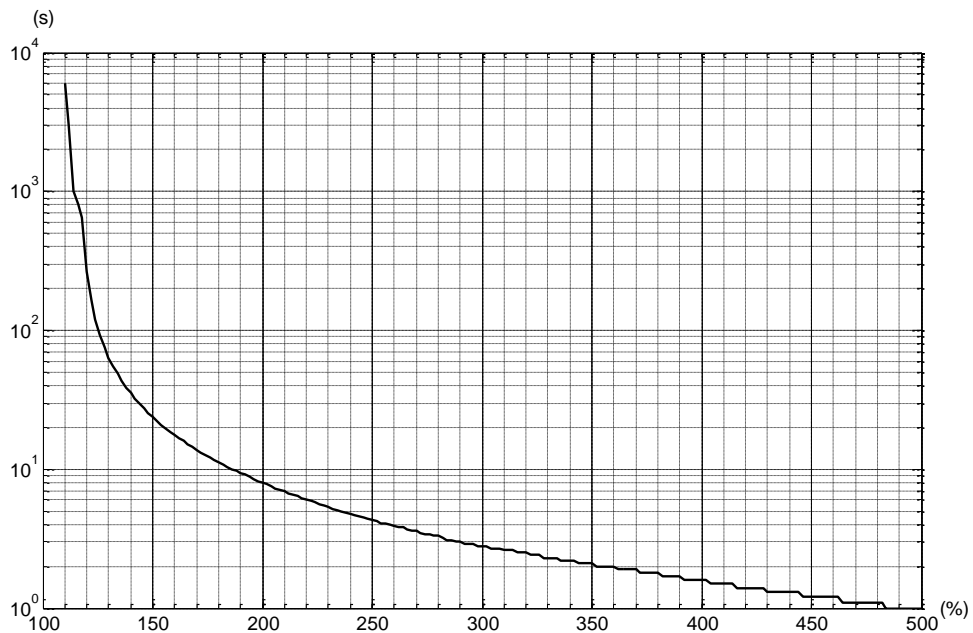

Load ratio	120%	140%	160%	180%	200%	220%	240%
Operating time	263.8 s	35.2 s	17.6 s	11.2 s	8 s	6.1 s	4.8 s
Load ratio	260%	280%	300%	350%	400%	450%	500%
Operating time	3.9 s	3.3 s	2.8 s	2.1 s	1.6 s	1.2 s	1.0 s



### A.2.5 Dimensions of ECM-A3L/A3H series servo motor

Motor frame size: 80 mm and below

A

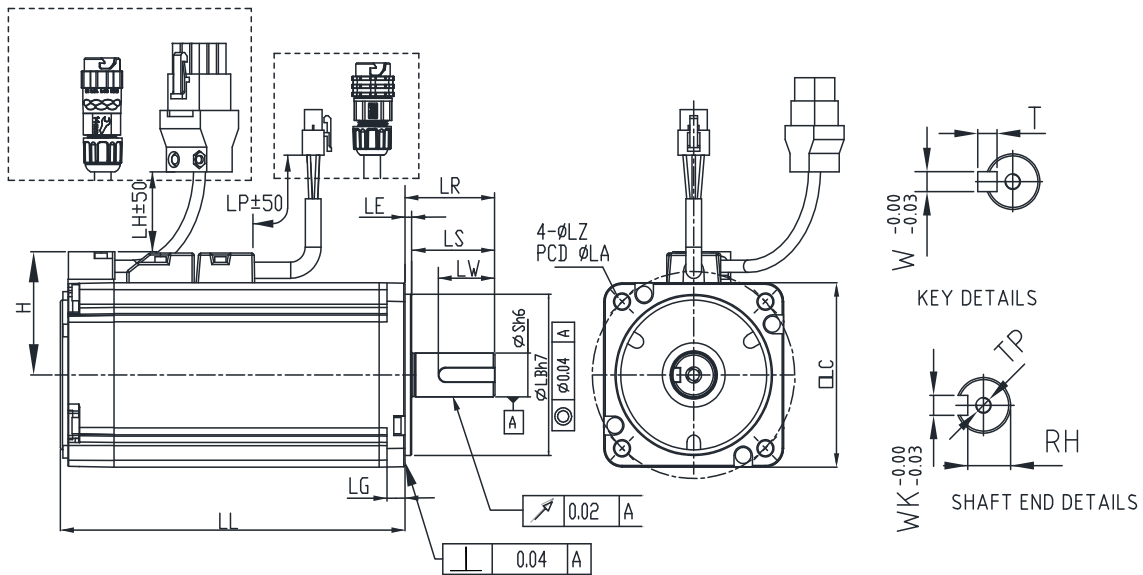

Unit: mm

ECM-A3L- ECM-A3H-	C□040F□□□	C□0401□□□	C□0602□□□	C□0604□□□	C□0804□□□	C□0807□□□
LC	40	40	60	60	80	80
LZ	4.5	4.5	5.5	5.5	6.6	6.6
LA	46	46	70	70	90	90
S	8 <sup>(+0/-0.009)</sup>	8 <sup>(+0/-0.009)</sup>	14 <sup>(+0/-0.011)</sup>	14 <sup>(+0/-0.011)</sup>	14 <sup>(+0/-0.011)</sup>	19 <sup>(+0/-0.013)</sup>
LB	30 <sup>(+0/-0.021)</sup>	30 <sup>(+0/-0.021)</sup>	50 <sup>(+0/-0.025)</sup>	50 <sup>(+0/-0.025)</sup>	70 <sup>(+0/-0.030)</sup>	70 <sup>(+0/-0.030)</sup>
LL (w/o brake)	70.6	85.3	84	106	93.7	115.8
LL (with brake)	105.4	120.1	117.6	139.7	131.2	153.2
LH	300	300	300	300	300	300
LP	300	300	300	300	300	300
H	34	34	43.5	43.5	54.5	54.5
LS	21.5	21.5	27	27	27	37
LR	25	25	30	30	30	40
LE	2.5	2.5	3	3	3	3
LG	5	5	7.5	7.5	8	8
LW	16	16	20	20	20	25
RH	6.2	6.2	11	11	11	15.5
WK	3	3	5	5	5	6
W	3	3	5	5	5	6
T	3	3	5	5	5	6
TP	M3 Depth 6	M3 Depth 6	M4 Depth 8	M4 Depth 8	M4 Depth 8	M6 Depth 10

Note:

1. When the special code (■) of C□0807□S■ is Z, LS = 32 and LR = 35.
2. CHOGORI (IP67) connectors are available for F80 and below models. Refer to Section A.2 for detailed model descriptions.

## A.3 ECM-B3 series servo motor

### ECM-B3 series servo motor model explanation

$$\frac{\text{ECM}}{(1)} - \frac{\text{B}}{(2)} \frac{\text{3}}{(3)} \frac{\text{M}}{(4)} - \frac{\text{C}}{(5)} \frac{\text{2}}{(6)} \frac{\text{06}}{(7)} \frac{\text{04}}{(8)} \frac{\text{R}}{(9)} \frac{\text{S}}{(10)} \frac{\text{1}}{(11)}$$

# A

(1) Product name

ECM: electronically commutated motor

(2) Servo type

B: general type servo motor

(3) Series

3: 3<sup>rd</sup> series

(4) Inertia

H: high inertia

M: medium inertia

L: low inertia

(5) Rated voltage and speed

C: 220V and 3,000 rpm

E: 220V and 2,000 rpm

F: 220V and 1,500 rpm

J: 400V and 3,000 rpm

K: 400V and 2,000 rpm

L: 400V and 1,500 rpm

(6) Encoder type

A: 24-bit absolute optical encoder

(resolution of single turn: 24-bit; number of revolutions: 16-bit)

2: 24-bit incremental optical encoder (single-turn absolute)

P: 17-bit absolute magnetic encoder

(resolution of single turn: 17-bit; number of revolutions: 16-bit)

M: 17-bit incremental magnetic encoder (single-turn absolute)

Note: number of revolutions means the maximum number of turns the encoder can record.

(7) Motor frame size

Code	Specification	Code	Specification
04	40 mm	13	130 mm
06	60 mm	18	180 mm
08	80 mm	22	220 mm
10	100 mm	-	-

A

(8) Rated power output

Code	Specification	Code	Specification
01	100 W	18	1.8 kW
02	200 W	20	2.0 kW
04	400 W	30	3.0 kW
07	750 W	45	4.5 kW
08	850 W	55	5.5 kW
10	1.0 kW	75	7.5 kW
13	1.3 kW	1B	11 kW
15	1.5 kW	1F	15 kW

(9) Shaft type and oil seal

	w/o brake, with oil seal	with brake, with oil seal
Keyway (with fixed screw holes)	R	S

(10) Shaft diameter and connector type

S: standard shaft diameter and standard connectors

7: special shaft diameter (14 mm)\*1 and standard connectors

J: standard shaft diameter and CHOGORI (IP67) connectors

K: special shaft diameter (14 mm)\*1 and CHOGORI (IP67) connectors

3: standard shaft diameter (42 mm)\*2 and standard connectors

B: standard shaft diameter and bulkhead connectors

Note:

1. Special shaft diameter (14 mm) is only available for F80 400 W models.

2. Standard shaft diameter (42 mm) is only available for F180 5.5 kW and 7.5 kW models and F220 11 kW models.

(11) Special code

1: standard products

### A.3.1 Specifications of ECM-B3 series servo motor

#### A.3.1.1 220V series

##### Motor frame size: 80 mm and below (low & medium inertia)

ECM-		B3L-C□0401	B3M-C□0602	B3M-C□0604	B3M-C□0804	B3M-C□0807	B3M-C□0810
Rated power (kW)		0.1	0.2	0.4	0.4	0.75	1.0
Rated torque (N·m) <sup>1</sup>		0.32	0.64	1.27	1.27	2.4	3.18
Max. torque (N·m)		1.12	2.24	4.45	4.45	8.4	11.13
Rated speed (rpm)		3000					
Max. speed (rpm)		6000					
Rated current (Arms)		0.857	1.42	2.40	2.53	4.27	5.00
Max. instantaneous current (Arms)		3.44	6.62	9.47	9.42	15.8	18.2
Change of rated power (kW/s)	w/o brake	34.25	29.05	63.50	24.89	53.83	73.8
	with brake	32.51	27.13	61.09	23.21	50.97	72.2
Rotor inertia (× 10 <sup>-4</sup> kg·m <sup>2</sup> )	w/o brake	0.0299	0.141	0.254	0.648	1.07	1.37
	with brake	0.0315	0.151	0.264	0.695	1.13	1.40
Mechanical time constant (ms)	w/o brake	0.50	0.91	0.52	0.8	0.54	0.48
	with brake	0.53	0.97	0.54	0.86	0.57	0.49
Torque constant-KT (N·m/Arms)		0.374	0.45	0.53	0.5	0.56	0.64
Voltage constant-KE (mVrms/rpm)		13.8	16.96	19.76	18.97	20.17	23.15
Armature resistance (Ohm)		8.22	4.71	2.04	1.125	0.55	0.495
Armature inductance (mH)		19.1	12.18	6.50	5.14	2.81	2.63
Electrical time constant (ms)		2.32	2.59	3.19	4.57	5.11	5.31
Weight (kg)	w/o brake	0.5	0.9	1.2	1.7	2.34	2.82
	with brake	0.7	1.3	1.6	2.51	3.15	3.60
Max. radial load (N)		78	245	245	392	392	392
Max. axial load (N)		54	74	74	147	147	147
Brake operating voltage		24 V <sub>DC</sub> ± 10%					
Brake power consumption (W) (at 20°C (68°F))		6.1	7.6	7.6	8	8	10
Brake holding torque [N·m (Min)] <sup>2</sup>		0.3	1.3	1.3	2.5	2.5	3.8
Brake release time [ms (Max)]		20	20	20	20	20	40
Brake pull-in time [ms (Max)]		35	50	50	60	60	80
Derating rate with oil seal (%)		10	10	5	5	5	5
Insulation class		Class A (UL), Class B (CE)					
Insulation resistance		100 MΩ min. (at 500 V <sub>DC</sub> )					
Insulation strength		1.8 kV <sub>AC</sub> , 1 sec					
Vibration grade		V15					
Ambient temperature		-20°C to +60°C (-4°F to +140°F) <sup>3</sup>					
Storage temperature		-20°C to +80°C (-4°F to +176°F)					
Ambient and storage humidity		20 - 90% RH (non-condensing)					
Vibration capacity		2.5 G					

A

A

ECM-	B3L-C□0401	B3M-C□0602	B3M-C□0604	B3M-C□0804	B3M-C□0807	B3M-C□0810
IP rating	IP67 (for models using waterproof connectors and shaft seals or oil seals)					
Approvals						

Note:

1. The rated torque is the continuous permissible torque when the servo motor mounted with the heat sink of the following dimensions is operating in a temperature range of 0°C and 40°C (32°F and 104°F).  
 F40, F60, and F80: 250 mm x 250 mm x 6 mm  
 Material: aluminum
2. The built-in servo motor brake is only for keeping the object in a stopped state. Do not use it for deceleration or as a dynamic brake.
3. If the ambient temperature is over 40°C (104°F), refer to Section A.3.3 Power derating curves of the B3 motors.
4. Follow the load specification for the motor shaft during operation. The load for the motor shaft is defined as follows.

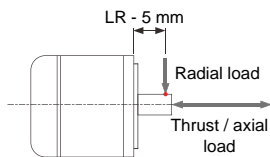

## Motor frame size: 80 mm and below (high inertia)

ECM-		B3H-C□0602	B3H-C□0604	B3H-C□0807
Rated power (kW)		0.2	0.4	0.75
Rated torque (N·m) <sup>*1</sup>		0.64	1.27	2.4
Max. torque (N·m)		2.43	4.83	9.12
Rated speed (rpm)		3000	3000	3000
Max. speed (rpm)		6700	6700	6700
Rated current (Arms)		1.51	2.21	4.19
Max. instantaneous current (Arms)		6.12	8.46	16.3
Change of rated power (kW/s)	w/o brake	15.5	30.8	37.2
	with brake	14.6	30.0	35.6
Rotor inertia (× 10 <sup>-4</sup> kg·m <sup>2</sup> )	w/o brake	0.265	0.523	1.55
	with brake	0.280	0.538	1.62
Mechanical time constant (ms)	w/o brake	1.78	1.31	0.825
	with brake	1.88	1.34	0.862
Torque constant-KT (N·m/Arms)		0.424	0.575	0.573
Voltage constant-KE (mVrms/rpm)		15.3	20.8	20.2
Armature resistance (Ohm)		4.17	2.85	0.588
Armature inductance (mH)		2	3.5	1
Electrical time constant (ms)		0.48	1.23	1.70
Weight (kg)	w/o brake	0.70	1.05	2.15
	with brake	1.23	1.6	2.95
Max. radial load (N)		245	245	392
Max. axial load (N)		74	74	147
Brake operating voltage		24 V <sub>DC</sub> ± 10%		
Brake power consumption (W) (at 20°C (68°F))		7.6	7.6	8
Brake holding torque [N·m (Min)] <sup>*2</sup>		1.3	1.3	2.5
Brake release time [ms (Max)]		20	20	20
Brake pull-in time [ms (Max)]		50	50	60
Derating rate with oil seal (%)		10	5	5
Insulation class		Class A (UL), Class B (CE)		
Insulation resistance		100 MΩ min. (at 500 V <sub>DC</sub> )		
Insulation strength		1.8 kV <sub>AC</sub> , 1 sec		
Vibration grade		V15		
Ambient temperature		-20°C to +60°C (-4°F to +140°F) <sup>*3</sup>		
Storage temperature		-20°C to +80°C (-4°F to +176°F)		
Ambient and storage humidity		20 - 90% RH (non-condensing)		
Vibration capacity		2.5 G		
IP rating		IP67 (for models using waterproof connectors and shaft seals or oil seals)		
Approvals				

A

A

Note:

1. The rated torque is the continuous permissible torque when the servo motor mounted with the heat sink of the following dimensions is operating in a temperature range of 0°C - 40°C (32°F - 104°F).  
 F40, F60, and F80: 250 mm x 250 mm x 6 mm  
 Material: aluminum
2. The built-in servo motor brake is only for keeping the object installed on the motor in a stopped state. Do not use it for deceleration or as a dynamic brake.
3. If the ambient temperature is over 40°C (104°F), refer to Section A.2.3 Power derating curves of the B3 motor.
4. Follow the load specification for the motor shaft during operation. The load for the motor shaft is defined as follows.

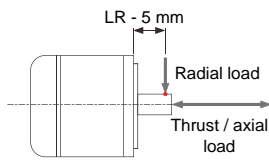

**Motor frame size: 100 mm (medium inertia)**

ECM-		B3M-C□1010	B3M-C□1015	B3M-C□1020
Rated power (kW)		1	1.5	2
Rated torque (N·m) <sup>*1</sup>		3.18	4.77	6.37
Max. torque (N·m)		9.54	14.31	19.11
Rated speed (rpm)		3000		
Max. speed (rpm)		6000		
Rated current (Arms)		6.05	7.48	9.96
Max. instantaneous current (Arms)		18.4	22.8	30.7
Change of rated power (kW/s)	w/o brake	36.4	61.7	86.7
	with brake	33.0	57.3	82.0
Rotor inertia (× 10 <sup>-4</sup> kg·m <sup>2</sup> )	w/o brake	2.78	3.69	4.68
	with brake	3.06	3.97	4.95
Mechanical time constant (ms)	w/o brake	0.741	0.552	0.523
	with brake	0.815	0.594	0.554
Torque constant-KT (N·m/Arms)		0.526	0.638	0.640
Voltage constant-KE (mVrms/rpm)		19.8	23.8	23.7
Armature resistance (Ohm)		0.265	0.217	0.162
Armature inductance (mH)		1.86	1.71	1.23
Electrical time constant (ms)		7.02	7.88	7.59
Weight (kg)	w/o brake	3.56	4.37	5.09
	with brake	4.88	5.68	6.51
Max. radial load (N)		490	490	490
Max. axial load (N)		196	196	196
Brake operating voltage		24 V <sub>DC</sub> ± 10%		
Brake power consumption (W) (at 20°C (68°F))		17.6	17.6	17.6
Brake holding torque [N·m (Min)] <sup>*2</sup>		9.5	9.5	9.5
Brake release time [ms (Max)]		50	50	50
Brake pull-in time [ms (Max)]		110	110	110
Derating rate with oil seal (%)		5	5	5
Insulation class		Class A (UL), Class B (CE)		
Insulation resistance		100 MΩ min. (at 500 V <sub>DC</sub> )		
Insulation strength		1.8 kV <sub>AC</sub> , 1 sec		
Vibration grade		V15		
Ambient temperature		-20°C to +60°C (-4°F to +140°F) <sup>*3</sup>		
Storage temperature		-20°C to +80°C (-4°F to +176°F)		
Ambient and storage humidity		20 - 90% RH (non-condensing)		
Vibration capacity		2.5 G		
IP rating		IP67 (for models using shaft seals or oil seals)		
Approvals				

A



A

Note:

1. The rated torque is the continuous permissible torque when the servo motor mounted with the heat sink of the following dimensions is operating in a temperature range of 0°C and 40°C (32°F and 104°F).  
 F100: 300 mm x 300 mm x 12 mm  
 Material: aluminum
2. The built-in servo motor brake is only for keeping the object in a stopped state. Do not use it for deceleration or as a dynamic brake.
3. If the ambient temperature is over 40°C (104°F), refer to Section A.3.3 Power derating curves of the B3 motors.
4. Follow the load specification for the motor shaft during operation. The load for the motor shaft is defined as follows.

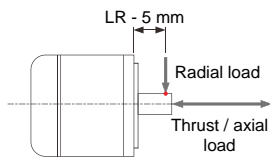

## Motor frame size: 130 mm (medium &amp; high inertia)

ECM-	B3M- E□1310	B3M- E□1315	B3M- E□1320	B3H- F□1308	B3H- F□1313	B3H- F□1318	
Rated power (kW)	1	1.5	2	0.85	1.3	1.8	
Rated torque (N·m) <sup>*1</sup>	4.77	7.16	9.55	5.39	8.34	11.5	
Max. torque (N·m)	14.3	21.48	28.65	16.17	25.02	34.5	
Rated speed (rpm)	2000			1500			
Max. speed (rpm)	3000			4000			
Rated current (Arms)	5.96	8.17	10.59	6.65	7.70	11.5	
Max. instantaneous current (Arms)	19.9	26.82	34.20	20.0	23.9	36.1	
Change of rated power (kW/s)	w/o brake	29.21	45.69	62.25	23.4	38.6	58.5
	with brake	28.66	45.09	61.62	23.0	38.3	58.0
Rotor inertia (× 10 <sup>-4</sup> kg·m <sup>2</sup> )	w/o brake	7.79	11.22	14.65	12.44	18.00	22.60
	with brake	7.94	11.37	14.8	12.62	18.14	22.80
Mechanical time constant (ms)	w/o brake	1.46	1.10	1.03	2.48	1.98	1.70
	with brake	1.49	1.12	1.04	2.52	1.99	1.71
Torque constant-KT (N·m/Arms)	0.80	0.88	0.90	0.811	1.08	1.00	
Voltage constant-KE (mVrms/rpm)	29.30	31.69	32.70	29.8	38.8	35.3	
Armature resistance (Ohm)	0.419	0.260	0.198	0.460	0.440	0.253	
Armature inductance (mH)	4	2.81	2.18	2.50	2.76	1.70	
Electrical time constant (ms)	9.55	10.81	11.01	5.43	6.27	6.72	
Weight (kg)	w/o brake	4.9	6.0	7.0	6.0	7.0	8.0
	with brake	6.3	7.4	8.5	7.5	8.5	9.5
Max. radial load (N)	490	686	980	490	686	980	
Max. axial load (N)	98	343	392	98	343	392	
Brake operating voltage	24 V <sub>DC</sub> ± 10%						
Brake power consumption (W) (at 20°C (68°F))	21.5	21.5	21.5	24	24	24	
Brake holding torque [N·m (Min)] <sup>*2</sup>	10	10	10	16	16	16	
Brake release time [ms (Max)]	50	50	50	60	60	60	
Brake pull-in time [ms (Max)]	110	110	110	120	120	120	
Derating rate with oil seal (%)	5	5	5	5	5	5	
Insulation class	Class A (UL), Class B (CE)			Class F (UL), Class F (CE)			
Insulation resistance	100 MΩ min. (at 500 V <sub>DC</sub> )						
Insulation strength	1.8 kV <sub>AC</sub> , 1 sec						
Vibration grade	V15						
Ambient temperature	-20°C to +60°C (-4°F to +140°F) <sup>*3</sup>						
Storage temperature	-20°C to +80°C (-4°F to +176°F)						
Ambient and storage humidity	20 - 90% RH (non-condensing)						
Vibration capacity	2.5 G						
IP rating	IP67 (for models using shaft seals or oil seals)						
Approvals							

A

Note:

1. The rated torque is the continuous permissible torque when the servo motor mounted with the heat sink of the following dimensions is operating in a temperature range of 0°C and 40°C (32°F and 104°F).

F130: 400 mm x 400 mm x 20 mm

Material: aluminum

2. The built-in servo motor brake is only for keeping the object in a stopped state. Do not use it for deceleration or as a dynamic brake.
3. If the ambient temperature is over 40°C (104°F), refer to Section A.3.3 Power derating curves of the B3 motors.
4. Follow the load specification for the motor shaft during operation. The load for the motor shaft is defined as follows.

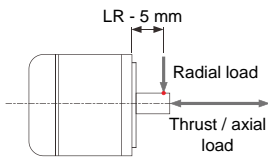

A

## Motor frame size: 180 mm (medium inertia)

ECM-		B3M-E□1820	B3M-F□1830	B3M-F□1845	B3M-F□1855	B3M-F□1875
Rated power (kW)		2	3	4.5	5.5	7.5
Rated torque (N·m) <sup>1</sup>		9.55	19.1	28.65	35.01	47.75
Max. torque (N·m)		28.65	57.29	71.6	105	119
Rated speed (rpm)		2000	1500	1500		
Max. speed (rpm)		3000	3000	4000		
Rated current (Arms)		11.43	18.21	26.6	30.7	44.2
Max. instantaneous current (Arms)		36.21	58.9	70.7	98.6	113.4
Change of rated power (kW/s)	w/o brake	31.33	68.02	121	124	169
	with brake	30.02	66.45	119	122	167
Rotor inertia (× 10 <sup>-4</sup> kg·m <sup>2</sup> )	w/o brake	29.11	53.63	67.73	98.88	134.95
	with brake	30.38	54.9	69.15	100.1	136.24
Mechanical time constant (ms)	w/o brake	1.83	1.21	1.06	1.01	1.01
	with brake	1.91	1.24	1.08	1.02	1.02
Torque constant-KT (N·m/A)		0.836	1.05	1.08	1.14	1.08
Voltage constant-KE (mVrms/rpm)		31.6	37.9	39.4	40.9	38.7
Armature resistance (Ohm)		0.159	0.086	0.0637	0.0454	0.0300
Armature inductance (mH)		2.34	1.52	1.17	0.867	0.568
Electrical time constant (ms)		14.72	17.67	18.4	19.1	18.9
Weight (kg)	w/o brake	10	13.9	16.5	21.2	27.2
	with brake	13.7	17.6	20.2	24.9	30.9
Max. radial load (N) <sup>4</sup>		1470	1470	1470	1764	1764
Max. axial load (N) <sup>4</sup>		490	490	490	588	588
Brake operating voltage		24 V <sub>DC</sub> ± 10%				
Brake holding torque [N·m (Min)] <sup>2</sup>		25	25	55	55	55
Brake power consumption [W] (at 20°C (68°F))		31	31	31	31	31
Brake release time [ms (Max)]		30	30	50	50	50
Brake pull-in time [ms (Max)]		120	120	150	150	150
Derating rate with oil seal (%)		5	5	0	0	0
Insulation class		Class A (UL), Class B (CE)		Class F (UL), Class F (CE)		
Insulation resistance		> 100 MΩ, DC 500V				
Insulation strength		1.8 kV <sub>AC</sub> , 1 sec				
Vibration grade		V15				
Ambient temperature		-20°C to +60°C (-4°F to +140°F) <sup>3</sup>				
Storage temperature		-20°C to +80°C (-4°F to 176°F)				
Ambient and storage humidity		20 - 90% RH (non-condensing)				
Vibration capacity		2.5 G				
IP rating		IP67 (for models using shaft seals or oil seals)				
Approvals						

A

## Note:

1. The rated torque is the continuous permissible torque when the servo motor mounted with the heat sink of the following dimensions is operating in a temperature range of 0°C and 40°C (32°F and 104°F).

F180: 550 mm x 550 mm x 30 mm

Material: aluminum

2. The built-in servo motor brake is only for keeping the object in a stopped state. Do not use it for deceleration or as a dynamic brake.
3. If the ambient temperature is over 40°C (104°F), refer to Section A.3.3 Power derating curves of the B3 motors.
4. Follow the load specification for the motor shaft during operation. The load for the motor shaft is defined as follows.

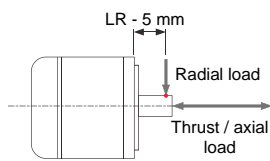

**Motor frame size: 220 mm (medium inertia)**

ECM-		B3M-F□221B	B3M-F□221F
Rated power (kW)		11	15
Rated torque (N·m) <sup>1</sup>		70.03	95.49
Max. torque (N·m)		175	238.5
Rated speed (rpm)		1500	
Max. speed (rpm)		4000	
Rated current (Arms)		45.1	72.8
Max. instantaneous current (Arms)		120.0	192.4
Change of rated power (kW/s)	w/o brake	162	228
	with brake	162	227
Rotor inertia (× 10 <sup>-4</sup> kg·m <sup>2</sup> )	w/o brake	302.2	400.0
	with brake	303.1	400.9
Mechanical time constant (ms)	w/o brake	1.07	1.04
	with brake	1.08	1.04
Torque constant-KT (N·m/A)		1.55	1.31
Voltage constant-KE (mVrms/rpm)		55.1	47.0
Armature resistance (Ohm)		0.0290	0.0153
Armature inductance (mH)		1.08	0.583
Electrical time constant (ms)		37.2	38.1
Weight (kg)	w/o brake	50.9	62.1
	with brake	58.2	69.4
Max. radial load (N) <sup>4</sup>		3300	3300
Max. axial load (N) <sup>4</sup>		1100	1100
Brake operating voltage		24 V <sub>DC</sub> ± 10%	
Brake holding torque [N·m (Min)] <sup>2</sup>		115	115
Brake power consumption [W] (at 20°C (68°F))		32	32
Brake release time [ms (Max)]		100	100
Brake pull-in time [ms (Max)]		300	300
Derating rate with oil seal (%)		0	0
Insulation class		Class F (UL), Class F (CE)	
Insulation resistance		> 100 MΩ, DC 500V	
Insulation strength		1.8 kV <sub>AC</sub> , 1 sec	
Vibration grade		V15	
Operating temperature		-20°C to +60°C (-4°F to +140°F) <sup>3</sup>	
Storage temperature		-20°C to +80°C (-4°F to 176°F)	
Operating and storage humidity		20 - 90% RH (non-condensing)	
Vibration capacity		2.5 G	
IP rating		IP67 (for models using shaft seals or oil seals)	
Approvals			

A

A

Note:

1. The rated torque is the continuous permissible torque when the servo motor mounted with the heat sink of the following dimensions is operating in a temperature range of 0°C and 40°C (32°F and 104°F).

F220: 650 mm x 650 mm x 35 mm

Material: aluminum

2. The built-in servo motor brake is only for keeping the object in a stopped state. Do not use it for deceleration or as a dynamic brake.
3. If the ambient temperature is over 40°C (104°F), refer to Section A.3.3 Power derating curves of the B3 motors.
4. Follow the load specification for the motor shaft during operation. The load for the motor shaft is defined as follows.

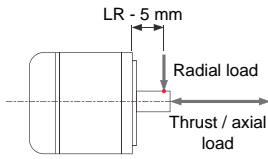

**A.3.1.2 400V series****Motor frame size: 80 mm and below (medium inertia)**

ECM-		B3M-J□0604	B3M-J□0807
Rated power (kW)		0.4	0.75
Rated torque (N·m) <sup>*1</sup>		1.27	2.4
Max. torque (N·m)		4.45	8.4
Rated speed (rpm)		3000	
Max. speed (rpm)		6000	
Rated current (Arms)		1.35	2.15
Max. instantaneous current (Arms)		5.20	7.90
Change of rated power (kW/s)	w/o brake	63.50	53.83
	with brake	61.09	50.97
Rotor inertia (× 10 <sup>-4</sup> kg·m <sup>2</sup> )	w/o brake	0.254	1.07
	with brake	0.264	1.13
Mechanical time constant (ms)	w/o brake	0.53	0.55
	with brake	0.55	0.58
Torque constant-KT (N·m/A)		0.94	1.12
Voltage constant-KE (mVrms/rpm)		34.66	40.34
Armature resistance (Ohm)		6.47	2.20
Armature inductance (mH)		20.6	11.2
Electrical time constant (ms)		3.18	5.09
Weight (kg)	w/o brake	1.2	2.34
	with brake	1.6	3.15
Max. radial load (N) <sup>*4</sup>		245	392
Max. axial load (N) <sup>*4</sup>		74	147
Brake holding torque [N·m (Min)] <sup>*2</sup>		1.3	2.5
Brake power consumption [W] (at 20°C (68°F))		7.6	8
Brake release time [ms (Max)]		20	20
Brake pull-in time [ms (Max)]		50	60
Derating rate with oil seal (%)		5	5
Insulation class		Class A (UL), Class B (CE)	
Insulation resistance		> 100 MΩ, DC 500V	
Insulation strength		2.3 kV <sub>AC</sub> , 1 sec	
Vibration grade		V15	
Ambient temperature		-20°C to +60°C (-4°F to +140°F) <sup>*3</sup>	
Storage temperature		-20°C to +80°C (-4°F to +140°F)	
Ambient and storage humidity		20 - 90% RH (non-condensing)	
Vibration capacity		2.5 G	
IP rating		IP67 (for models using waterproof connectors and shaft seals or oil seals)	
Approvals			

A



Note:

1. The rated torque is the continuous permissible torque when the servo motor mounted with the heat sink of the following dimensions is operating in a temperature range of 0°C and 40°C (32°F and 104°F).

F60 and F80: 250 mm x 250 mm x 6 mm

Material: aluminum

2. The built-in servo motor brake is only for keeping the object in a stopped state. Do not use it for deceleration or as a dynamic brake.
3. If the ambient temperature is over 40°C (104°F), refer to Section A.3.3 Power derating curves of the B3 motors.
4. Follow the load specification for the motor shaft during operation. The load for the motor shaft is defined as follows.

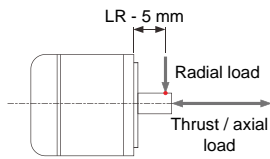

A

## Motor frame size: 100 mm (medium inertia)

ECM-		B3M-J□1010	B3M-J□1015	B3M-J□1020
Rated power (kW)		1	1.5	2
Rated torque (N·m) <sup>1</sup>		3.18	4.77	6.37
Max. torque (N·m)		9.54	14.31	19.11
Rated speed (rpm)		3000		
Max. speed (rpm)		6000		
Rated current (Arms)		3.03	3.73	5.00
Max. instantaneous current (Arms)		9.21	11.4	15.3
Change of rated power (kW/s)	w/o brake	36.4	61.7	86.7
	with brake	33.0	57.3	82.0
Rotor inertia (× 10 <sup>-4</sup> kg·m <sup>2</sup> )	w/o brake	2.78	3.69	4.68
	with brake	3.06	3.97	4.95
Mechanical time constant (ms)	w/o brake	0.737	0.546	0.528
	with brake	0.811	0.587	0.559
Torque constant-KT (N·m/Arms)		1.05	1.28	1.27
Voltage constant-KE (mVrms/rpm)		39.5	47.8	47.2
Armature resistance (Ohm)		1.05	0.864	0.646
Armature inductance (mH)		7.50	6.63	4.89
Electrical time constant (ms)		7.14	7.67	7.57
Weight (kg)	w/o brake	3.56	4.37	5.09
	with brake	4.88	5.68	6.505
Max. radial load (N) <sup>*4</sup>		490	490	490
Max. axial load (N) <sup>*4</sup>		196	196	196
Brake operating voltage		24 V <sub>DC</sub> ± 10%		
Brake power consumption (W) (at 20°C (68°F))		17.6	17.6	17.6
Brake holding torque [N·m (Min)] <sup>*2</sup>		9.5	9.5	9.5
Brake release time [ms (Max)]		50	50	50
Brake pull-in time [ms (Max)]		110	110	110
Derating rate with oil seal (%)		5	5	5
Insulation class		Class A (UL), Class B (CE)		
Insulation resistance		100 MΩ min. (at 500 V <sub>DC</sub> )		
Insulation strength		2.3 kV <sub>AC</sub> , 1 sec		
Vibration grade		V15		
Ambient temperature		-20°C to +60°C (-4°F to +140°F) <sup>*3</sup>		
Storage temperature		-20°C to +80°C (-4°F to +176°F)		
Ambient and storage humidity		20 - 90% RH (non-condensing)		
Vibration capacity		2.5 G		
IP rating		IP67 (for models using shaft seals or oil seals)		
Approvals				

A

Note:

1. The rated torque is the continuous permissible torque when the servo motor mounted with the heat sink of the following dimensions is operating in a temperature range of 0°C and 40°C (32°F and 104°F).

F100: 300 mm x 300 mm x 12 mm

Material: aluminum

2. The built-in servo motor brake is only for keeping the object in a stopped state. Do not use it for deceleration or as a dynamic brake.
3. If the ambient temperature is over 40°C (104°F), refer to Section A.3.3 Power derating curves of the B3 motors.
4. Follow the load specification for the motor shaft during operation. The load for the motor shaft is defined as follows.

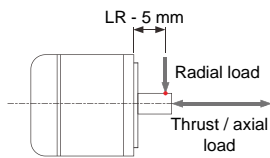

A

## Motor frame size: 130 mm (medium &amp; high inertia)

ECM-		B3M- K□1310	B3M- K□1315	B3M- K□1320	B3H- L□1308	B3H- L□1313	B3H- L□1318
Rated power (kW)		1.0	1.5	2.0	0.85	1.3	1.8
Rated torque (N·m) <sup>*1</sup>		4.77	7.16	9.55	5.39	8.34	11.5
Max. torque (N·m)		14.3	21.48	28.65	16.17	25.02	34.5
Rated speed (rpm)		2000			1500		
Max. speed (rpm)		3000			4000		
Rated current (Arms)		3.00	4.09	5.30	3.35	3.85	5.75
Max. instantaneous current (Arms)		9.95	13.37	17.1	10.0	12.0	18.1
Change of rated power (kW/s)	w/o brake	29.21	45.69	62.25	23.4	38.6	58.5
	with brake	28.66	45.09	61.62	23.0	38.3	58.0
Rotor inertia (× 10 <sup>-4</sup> kg·m <sup>2</sup> )	w/o brake	7.79	11.22	14.65	12.44	18.00	22.60
	with brake	7.94	11.37	14.80	12.62	18.14	22.80
Mechanical time constant (ms)	w/o brake	1.47	1.10	1.03	2.50	1.97	1.69
	with brake	1.50	1.12	1.04	2.54	1.99	1.71
Torque constant-KT (N·m/Arms)		1.59	1.75	1.80	1.61	2.17	2.00
Voltage constant-KE (mVrms/rpm)		58.60	63.38	65.40	59.5	77.6	70.7
Armature resistance (Ohm)		1.68	1.04	0.792	1.84	1.76	1.01
Armature inductance (mH)		16.0	11.2	8.72	10.0	11.0	6.80
Electrical time constant (ms)		9.52	10.8	11.0	5.43	6.25	6.73
Weight (kg)	w/o brake	4.9	6.0	7.0	6.0	7.0	8.0
	with brake	6.3	7.4	8.5	7.5	8.5	9.5
Max. radial load (N) <sup>*4</sup>		490	686	980	490	686	980
Max. axial load (N) <sup>*4</sup>		98	343	392	98	343	392
Brake operating voltage		24 V <sub>DC</sub> ± 10%					
Brake power consumption (W) (at 20°C (68°F))		21.5	21.5	21.5	24	24	24
Brake holding torque [N·m (Min)] <sup>*2</sup>		10	10	10	16	16	16
Brake release time [ms (Max)]		50	50	50	60	60	60
Brake pull-in time [ms (Max)]		110	110	110	120	120	120
Derating rate with oil seal (%)		5	5	5	5	5	5
Insulation class		Class A (UL), Class B (CE)			Class F (UL), Class F (CE)		
Insulation resistance		100 MΩ min. (at 500 V <sub>DC</sub> )					
Insulation strength		2.3 kV <sub>AC</sub> , 1 sec					
Vibration grade		V15					
Ambient temperature		-20°C to +60°C (-4°F to +140°F) <sup>*3</sup>					
Storage temperature		-20°C to +80°C (-4°F to +176°F)					
Ambient and storage humidity		20 - 90% RH (non-condensing)					
Vibration capacity		2.5 G					
IP rating		IP67 (for models using shaft seals or oil seals)					
Approvals							

A

A

Note:

1. The rated torque is the continuous permissible torque when the servo motor mounted with the heta sink of the following dimensions is operating in a temperature range of 0°C and 40°C (32°F and 104°F).

F130: 400 mm x 400 mm x 20 mm

Material: aluminum

2. The built-in servo motor brake is only for keeping the object in a stopped state. Do not use it for deceleration or as a dynamic brake.
3. If the ambient temperature is over 40°C (104°F), refer to Section A.3.3 Power derating curves of the B3 motors.
4. Follow the load specification for the motor shaft during operation. The load for the motor shaft is defined as follows.

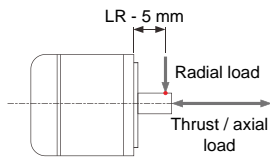

## Motor frame size: 180 mm (medium inertia)

ECM-		B3M- K□1820	B3M- L□1830	B3M- L□1845	B3M- L□1855	B3M- L□1875
Rated power (kW)		2	3	4.5	5.5	7.5
Rated torque (N·m) <sup>*1</sup>		9.55	19.1	28.65	35.01	47.75
Max. torque (N·m)		28.65	57.29	71.6	105	119
Rated speed (rpm)		2000	1500	1500		
Max. speed (rpm)		3000	3000	4000		
Rated current (Arms)		5.7	9.1	13.3	15.3	22.1
Max. instantaneous current (Arms)		18.1	29.45	35.35	49.29	56.68
Change of rated power (kW/s)	w/o brake	31.33	68.02	121	124	169
	with brake	30.02	66.45	119	122	167
Rotor inertia (× 10 <sup>-4</sup> kg·m <sup>2</sup> )	w/o brake	29.11	53.63	67.73	98.88	134.95
	with brake	30.38	54.9	69.15	100.1	136.24
Mechanical time constant (ms)	w/o brake	1.83	1.21	1.07	1.01	1.01
	with brake	1.91	1.24	1.09	1.02	1.02
Torque constant-KT (N·m/Arms)		1.68	2.10	2.15	2.29	2.16
Voltage constant-KE (mVrms/rpm)		63.2	75.8	78.8	81.8	77.4
Armature resistance (Ohm)		0.636	0.344	0.255	0.182	0.120
Armature inductance (mH)		9.36	6.08	4.68	3.48	2.27
Electrical time constant (ms)		14.72	17.67	18.4	19.1	18.9
Weight (kg)	w/o brake	10	13.9	16.5	21.2	27.2
	with brake	13.7	17.6	20.2	24.9	30.9
Max. radial load (N) <sup>*4</sup>		1470	1470	1470	1764	1764
Max. axial load (N) <sup>*4</sup>		490	490	490	588	588
Brake operating voltage		24 V <sub>DC</sub> ± 10%				
Brake power consumption (W) (at 20°C (68°F))		31	31	31	31	31
Brake holding torque [N·m (Min)] <sup>*2</sup>		25	25	55	55	55
Brake release time [ms (Max)]		30	30	50	50	50
Brake pull-in time [ms (Max)]		120	120	150	150	150
Derating rate with oil seal (%)		5	5	0	0	0
Insulation class		Class A (UL), Class B (CE)		Class F (UL), Class F (CE)		
Insulation resistance		100 MΩ min. (at 500 V <sub>DC</sub> )				
Insulation strength		2.3 kV <sub>AC</sub> , 1 sec				
Vibration grade		V15				
Ambient temperature		-20°C to +60°C (-4°F to +140°F) <sup>*3</sup>				
Storage temperature		-20°C to +80°C (-4°F to +176°F)				
Ambient and storage humidity		20 - 90% RH (non-condensing)				
Vibration capacity		2.5 G				
IP rating		IP67 (for models using shaft seals or oil seals)				
Approvals						

A

Note:

1. The rated torque is the continuous permissible torque when the servo motor mounted with the heat sink of the following dimensions is operating in a temperature range of 0°C and 40°C (32°F and 104°F).

F180: 550 mm x 550 mm x 30 mm

Material: aluminum

2. The built-in servo motor brake is only for keeping the object in a stopped state. Do not use it for deceleration or as a dynamic brake.
3. If the ambient temperature is over 40°C (104°F), refer to Section A.3.3 Power derating curves of the B3 motors.
4. Follow the load specification for the motor shaft during operation. The load for the motor shaft is defined as follows.

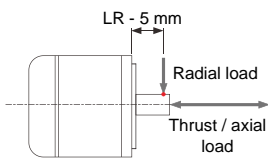

A

## Motor frame size: 220 mm (medium inertia)

ECM-		B3M-L□221B	B3M-L□221F
Rated power (kW)		11	15
Rated torque (N·m) <sup>*1</sup>		70.03	95.49
Max. torque (N·m)		175	238.5
Rated speed (rpm)		1500	
Max. speed (rpm)		4000	
Rated current (Arms)		21.2	29.2
Max. instantaneous current (Arms)		56.5	77
Change of rated power (kW/s)	w/o brake	162	228
	with brake	162	227
Rotor inertia (× 10 <sup>-4</sup> kg·m <sup>2</sup> )	w/o brake	302.2	400
	with brake	303.1	400.9
Mechanical time constant (ms)	w/o brake	1.03	0.94
	with brake	1.04	0.94
Torque constant-KT (N·m/A)		3.30	3.27
Voltage constant-KE (mVrms/rpm)		118	118
Armature resistance (Ohm)		0.127	0.0862
Armature inductance (mH)		3.69	2.43
Electrical time constant (ms)		29.1	28.2
Weight (kg)	w/o brake	50.9	62.1
	with brake	58.2	69.4
Max. radial load (N) <sup>*4</sup>		3300	3300
Max. axial load (N) <sup>*4</sup>		1100	1100
Brake holding torque [N·m (Min)] <sup>*2</sup>		115	115
Brake power consumption [W] (at 20°C (68°F))		32	32
Brake release time [ms (Max)]		100	100
Brake pull-in time [ms (Max)]		300	300
Derating rate with oil seal (%)		0	0
Insulation class		Class F (UL), Class F (CE)	
Insulation resistance		> 100 MΩ, DC 500V	
Insulation strength		2.3 kV <sub>AC</sub> , 1 sec	
Vibration grade		V15	
Operating temperature		-20°C to +60°C (-4°F to +140°F) <sup>*3</sup>	
Storage temperature		-20°C to +80°C (-4°F to +140°F)	
Operating and storage humidity		20 - 90% RH (non-condensing)	
Vibration capacity		2.5 G	
IP rating		IP67 (for models using shaft seals or oil seals)	
Approvals			

A



A

Note:

1. The rated torque is the continuous permissible torque when the servo motor mounted with the heat sink of the following dimensions is operating in a temperature range of 0°C and 40°C (32°F and 104°F).

F220: 650 mm x 650 mm x 35 mm

Material: aluminum

2. The built-in servo motor brake is only for keeping the object in a stopped state. Do not use it for deceleration or as a dynamic brake.
3. If the ambient temperature is over 40°C (104°F), refer to Section A.3.3 Power derating curves of the B3 motors.
4. Follow the load specification for the motor shaft during operation. The load for the motor shaft is defined as follows.

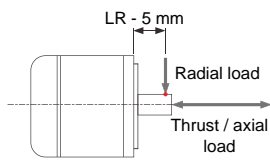

### A.3.2 Torque features (T-N curves) of the B3 motors

#### A.3.2.1 220V series

Motor frame size: 80 mm and below

A

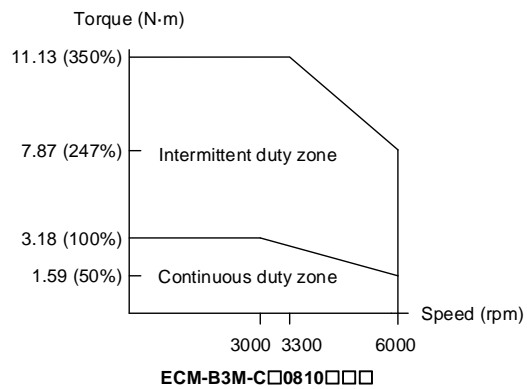
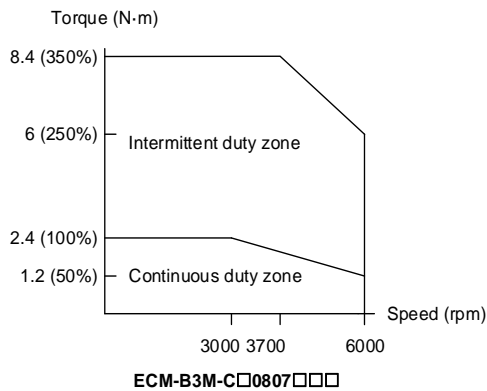
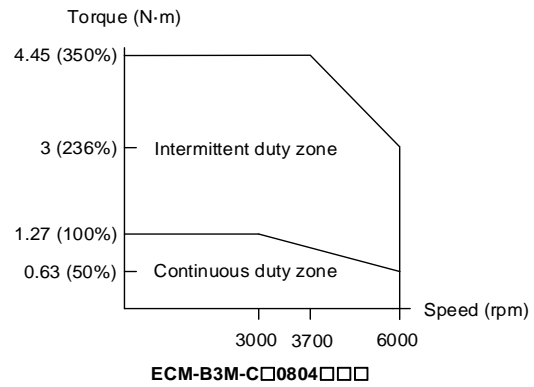
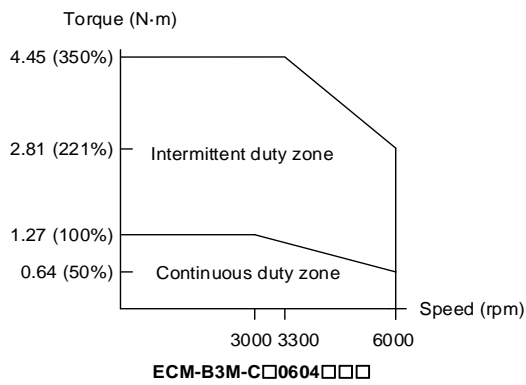
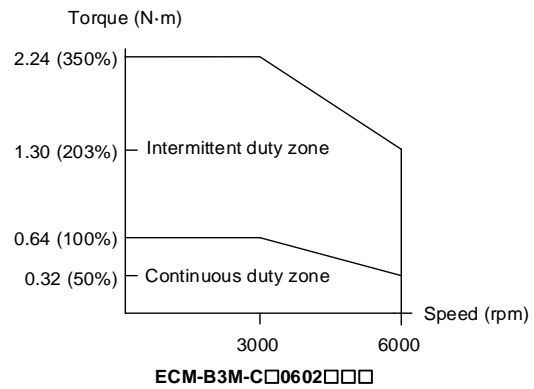
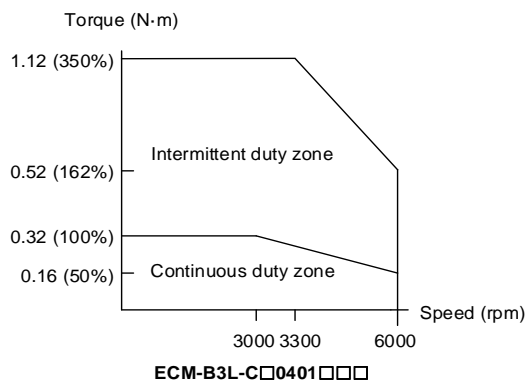

A

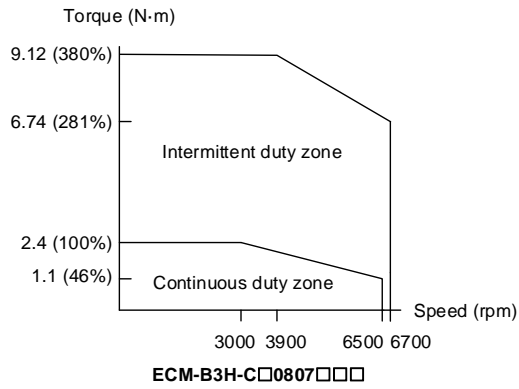
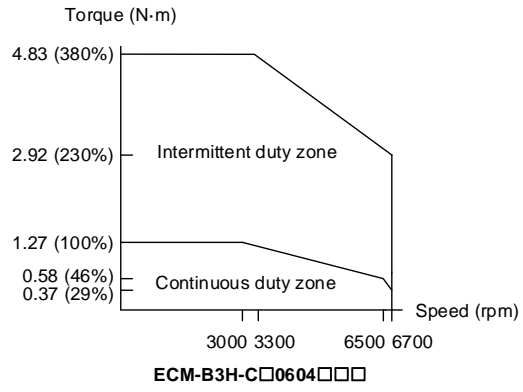
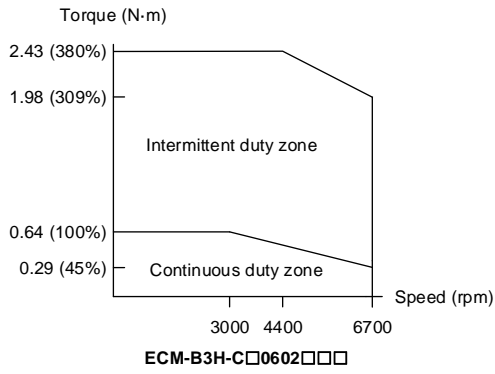

Motor frame size: 100 mm

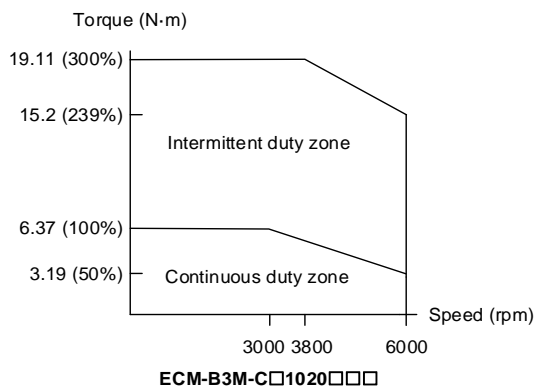
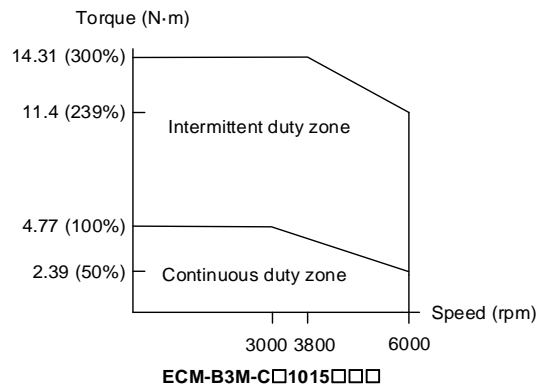
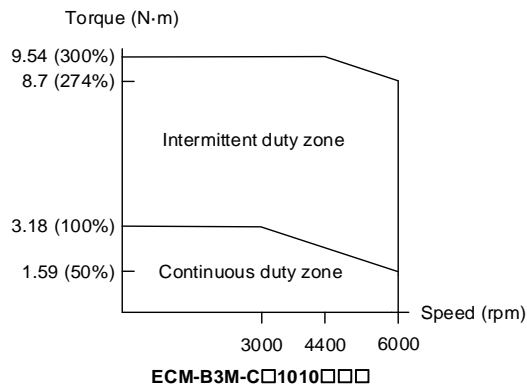

Motor frame size: 130 mm

A

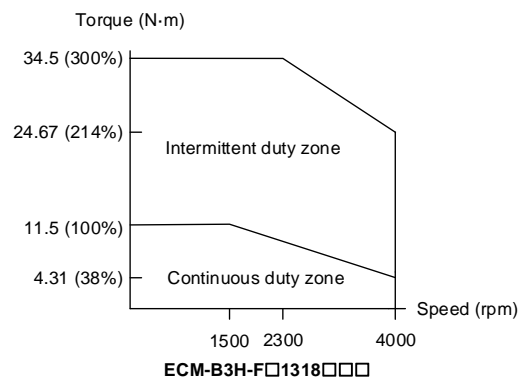
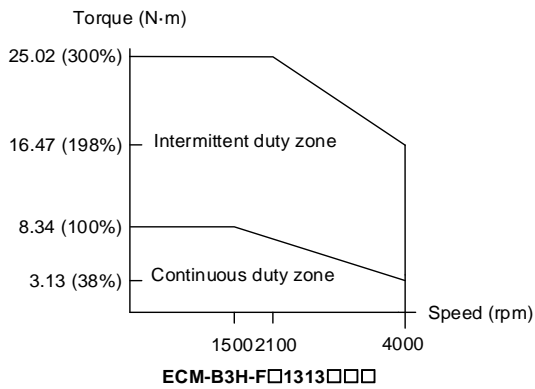
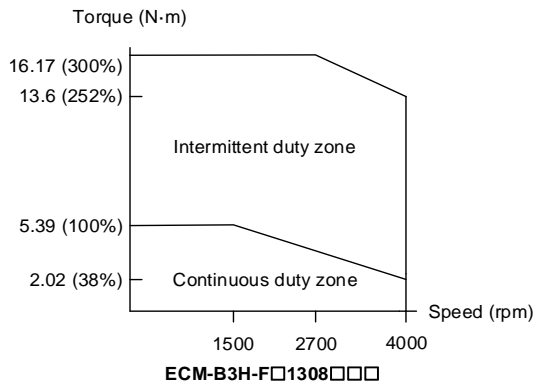
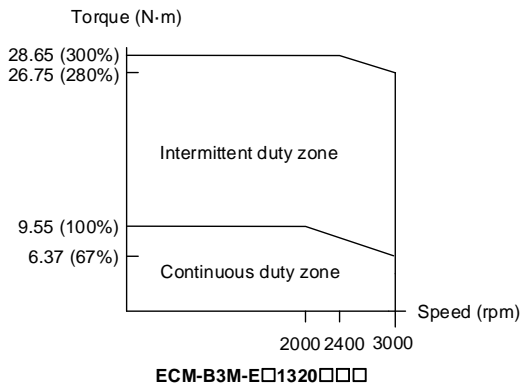
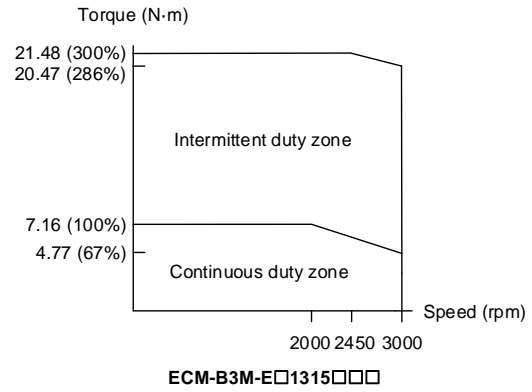
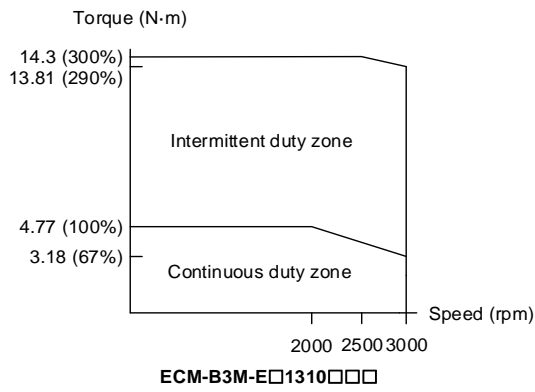

A

Motor frame size: 180 mm

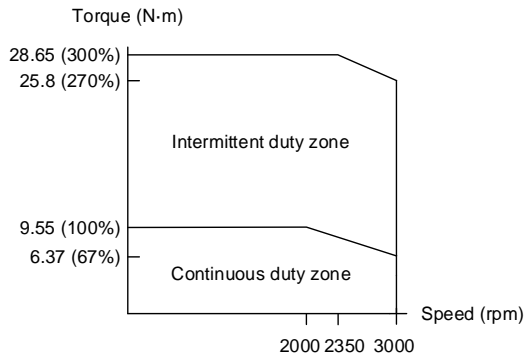

ECM-B3M-E1820

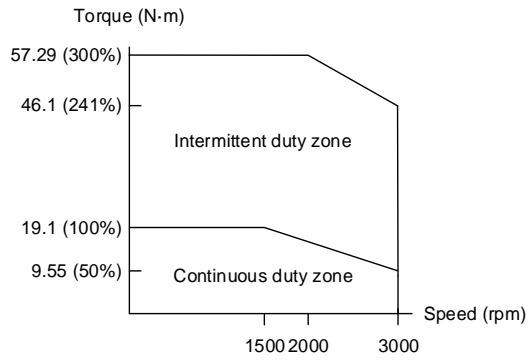

ECM-B3M-F1830

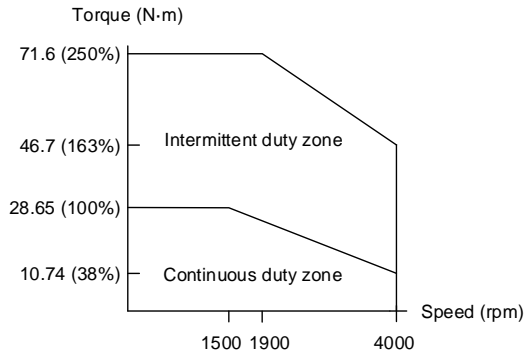

ECM-B3M-F1845

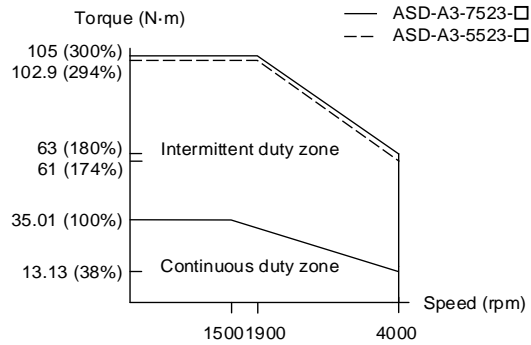

ECM-B3M-F1855

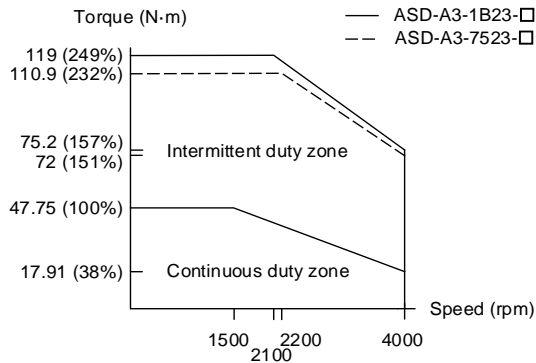

ECM-B3M-F1875

**Motor frame size: 220 mm**

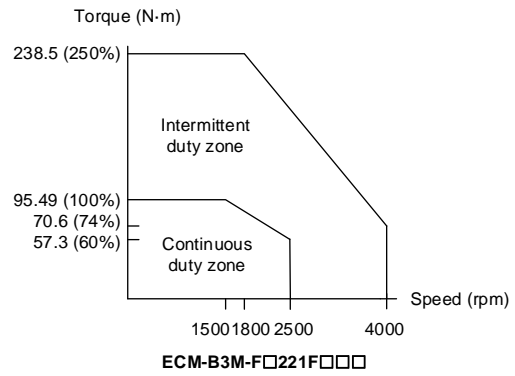
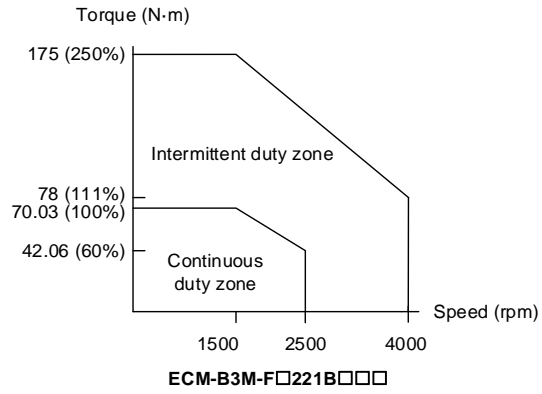

A

**A.3.2.2 400V series**

**Motor frame size: 80 mm and below**

A

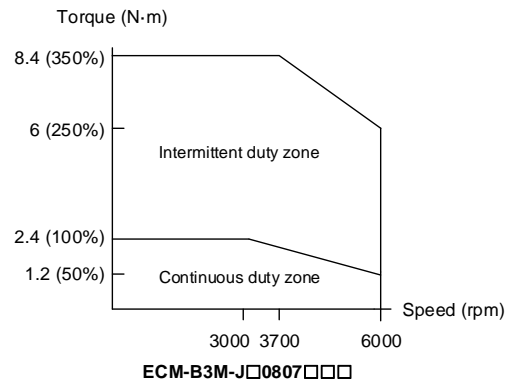
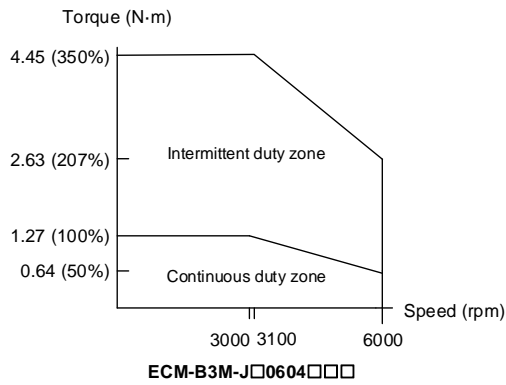

**Motor frame size: 100 mm**

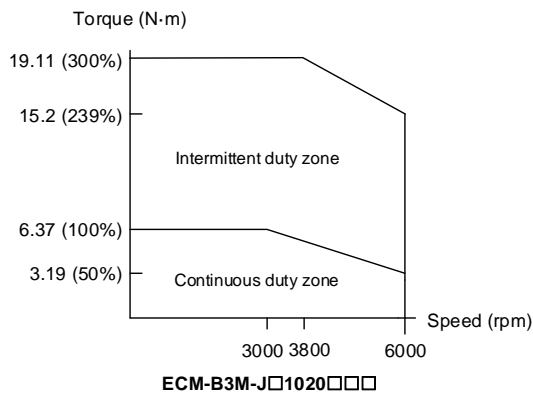
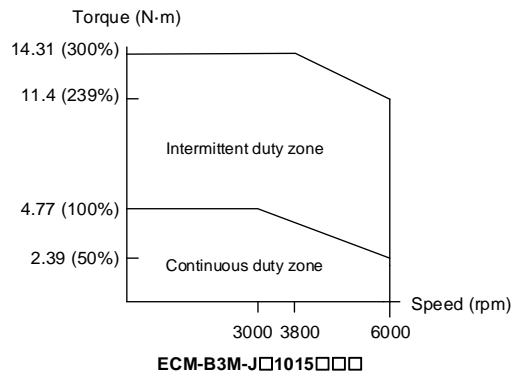
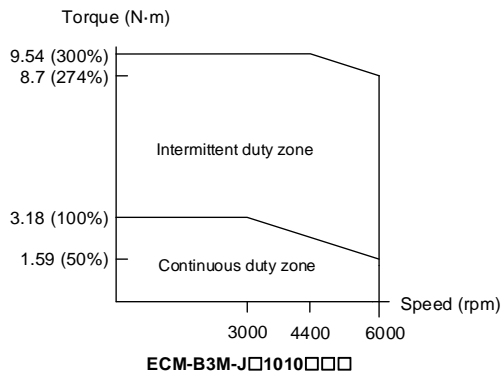

Motor frame size: 130 mm

A

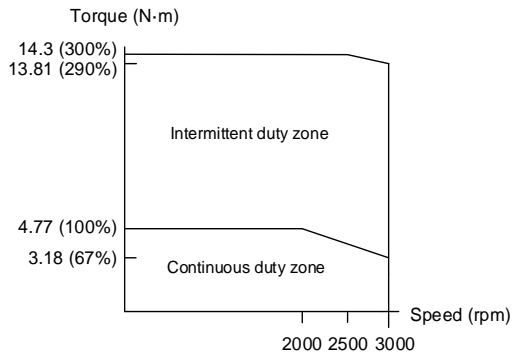

ECM-B3M-K□1310□□□

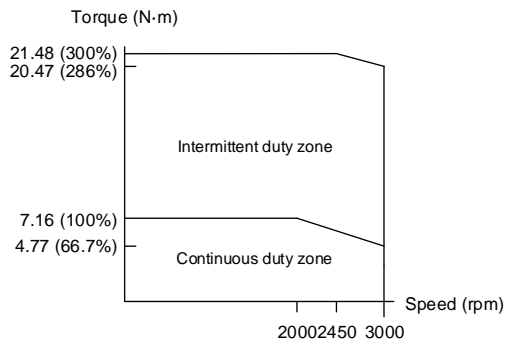

ECM-B3M-K□1315□□□

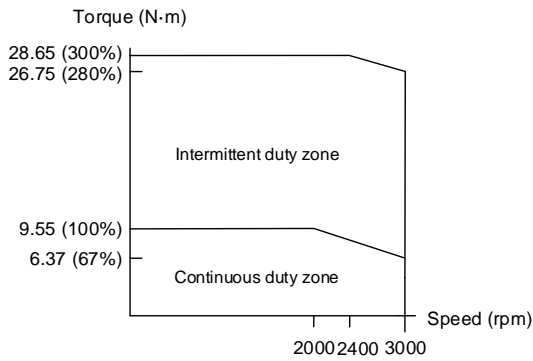

ECM-B3M-K□1320□□□

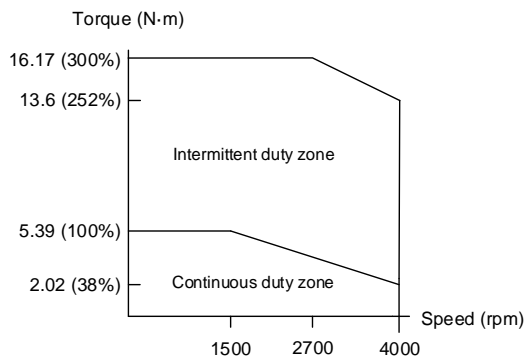

ECM-B3H-L□1308□□□

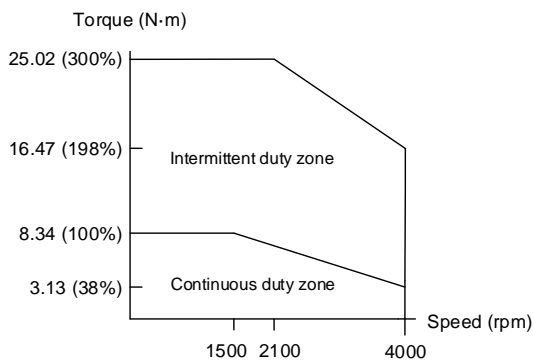

ECM-B3H-L□1313□□□

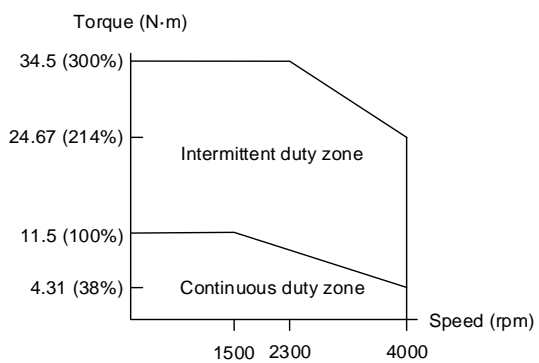

ECM-B3H-L□1318□□□



A

Motor frame size: 180 mm

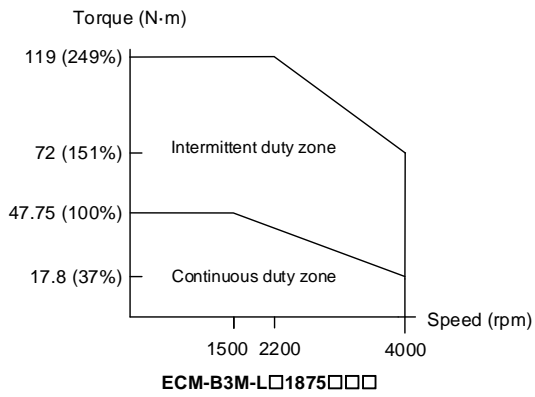
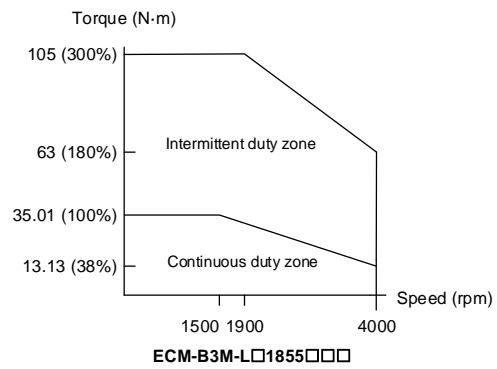
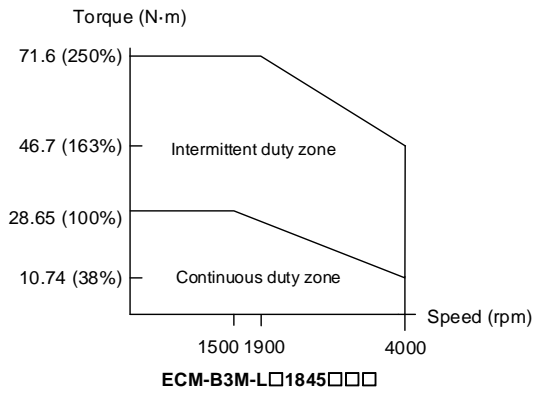
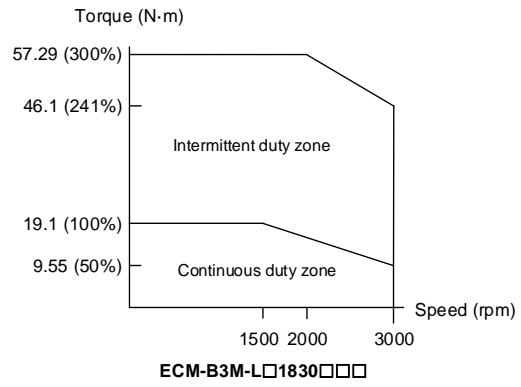
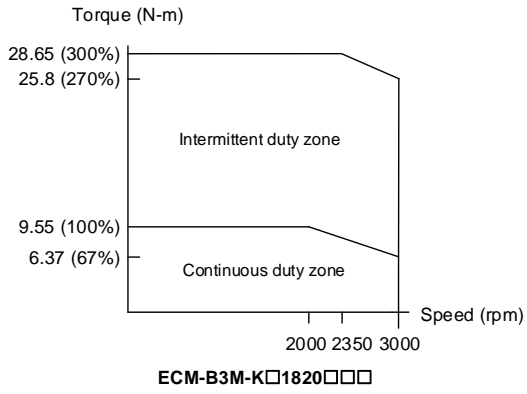

Motor frame size: 220 mm

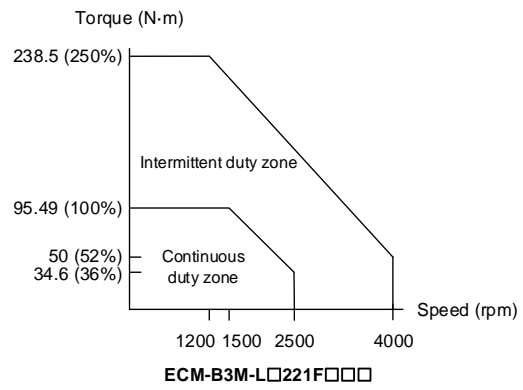
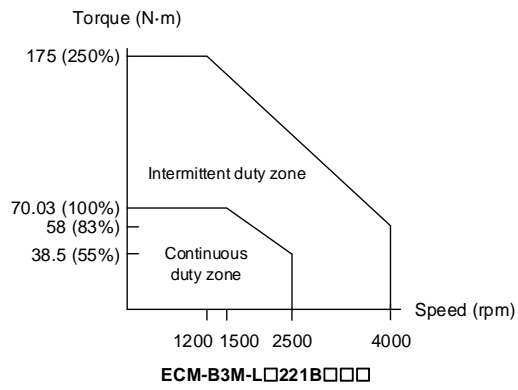

A

A

### A.3.3 Power derating curves of the B3 motors

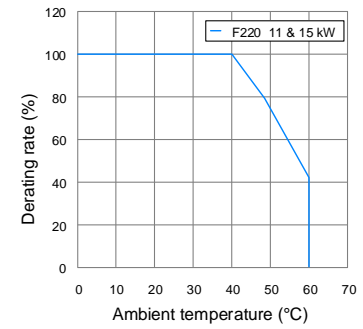
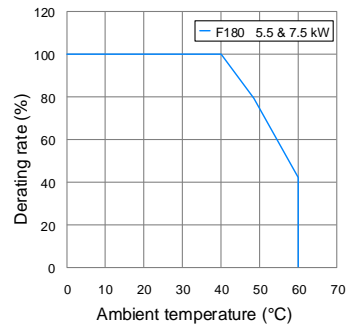
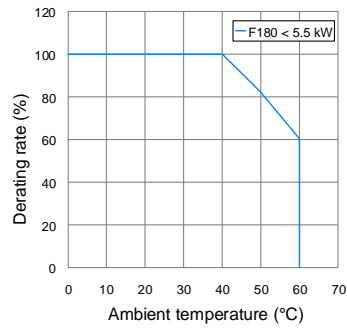
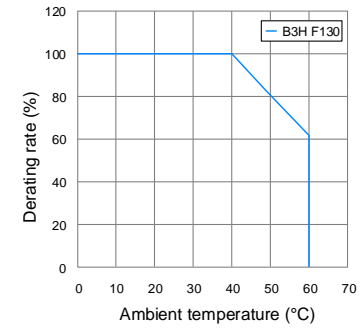
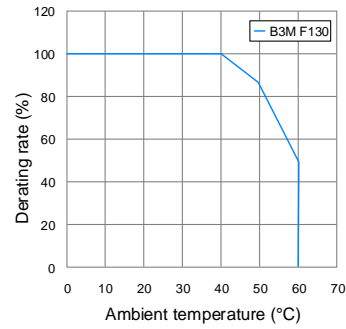
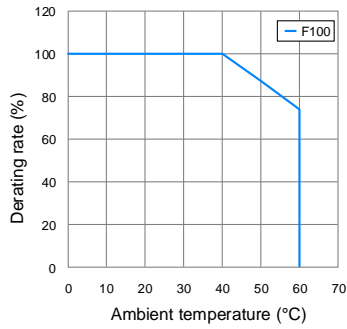
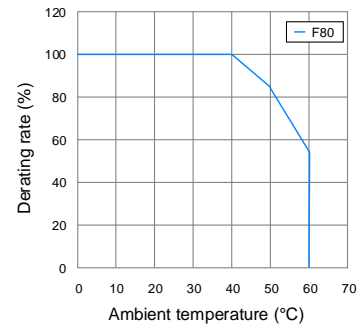
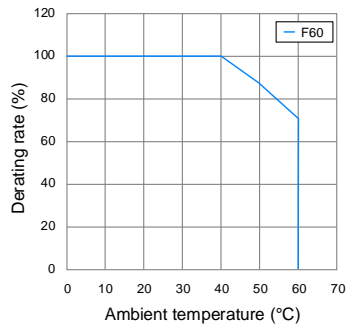
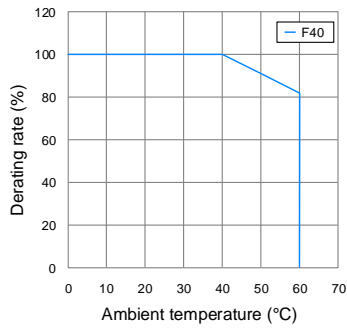

Note: the above specifications are applicable to 220V and 400V models.

### A.3.4 Overload features

#### Definition of overload protection

The overload protection prevents the motor from overheating.



#### Causes of overload

1. The motor's operating torque exceeds the rated range and the operating time is too long.
2. The inertia ratio is too high and the motor frequently accelerates and decelerates.
3. Incorrect wiring of the power and encoder cables.
4. Incorrect servo gain setting causes resonance in the motor.
5. A motor with a built-in brake operates without the brake released.

#### Graph of load and operating time

220V series: low inertia (ECM-B3L series), medium inertia (ECM-B3M-C series), high inertia (ECM-B3H-C series)

400V series: medium inertia (ECM-B3M-J series)

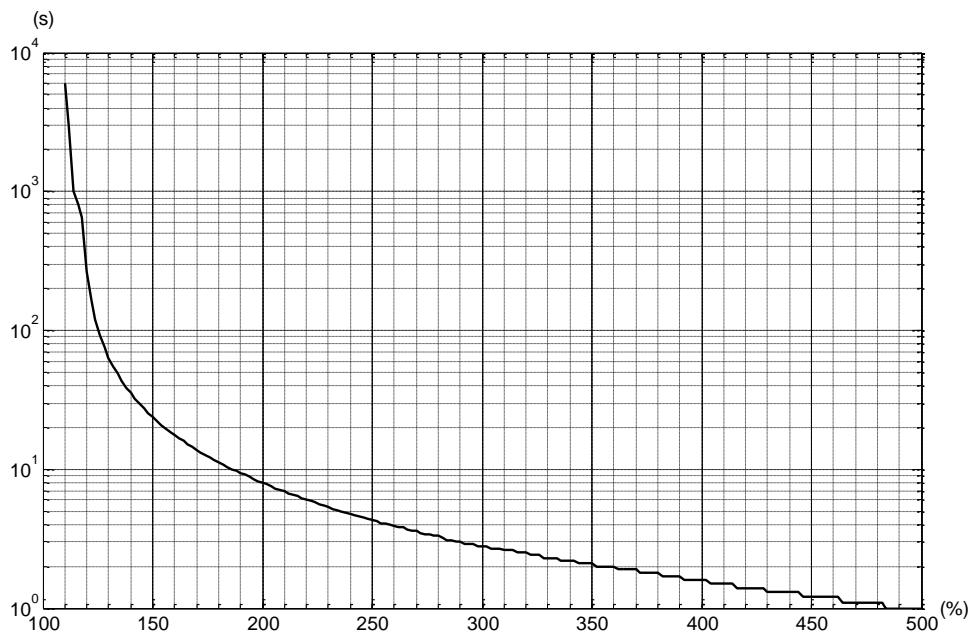

Load ratio	120%	140%	160%	180%	200%	220%	240%
Operating time	263.8 s	35.2 s	17.6 s	11.2 s	8 s	6.1 s	4.8 s
Load ratio	260%	280%	300%	350%	400%	450%	500%
Operating time	3.9 s	3.3 s	2.8 s	2.1 s	1.6 s	1.2 s	1.0 s

220V series: medium inertia (ECM-B3M-E / -F series), high inertia (ECM-B3H-F series)

400V series: medium inertia (ECM-B3M-K / -L series), high inertia (ECM-B3H-L series)

A

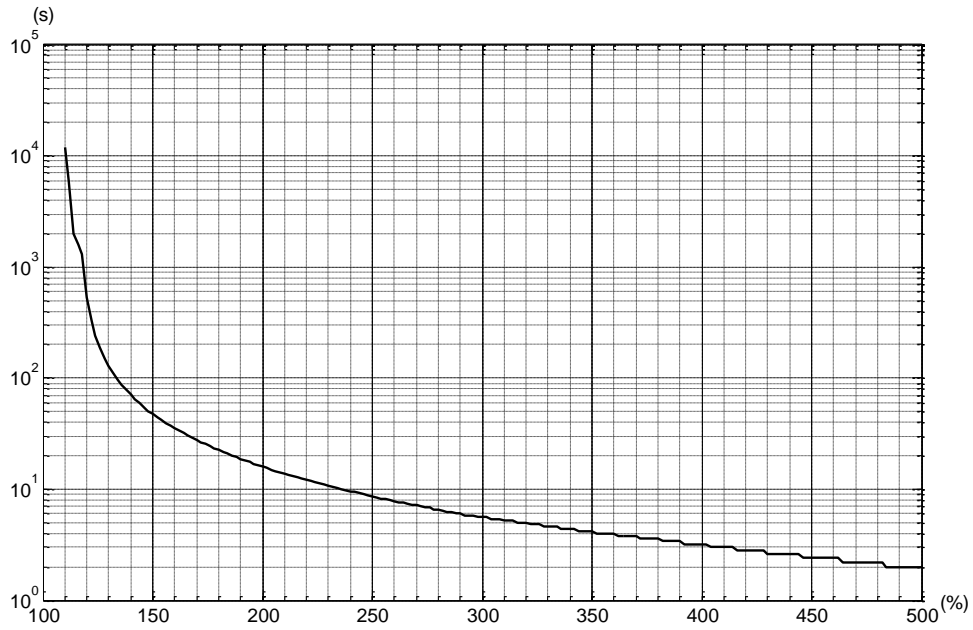

Load ratio	120%	140%	160%	180%	200%	220%	240%
Operating time	527.6 s	70.4 s	35.2 s	22.4 s	16 s	12.2 s	9.6 s
Load ratio	260%	280%	300%	350%	400%	450%	500%
Operating time	7.8 s	6.6 s	5.6 s	4.2 s	3.2 s	2.4 s	2.0 s



**Motor frame size: 80 mm and below, with bulkhead connectors (low & medium & high inertia)**

A

The motor is shipped without cables.

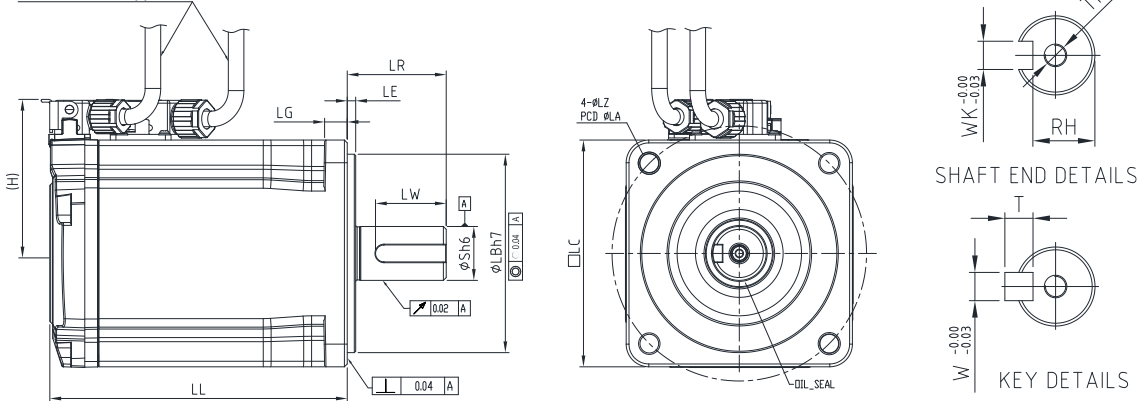

Unit: mm

ECM-	B3L-C□ 0401□B1	B3M-C□ 0602□B1	B3M-C□ 0604□B1	B3M-C□ 0807□B1	B3H-C□ 0602□B1	B3H-C□ 0604□B1	B3H-C□ 0807□B1
LC	40	60	60	80	60	60	80
LZ	4.5	5.5	5.5	6.6	5.5	5.5	6.6
LA	46	70	70	90	70	70	90
S	8 <sup>(+0/-0.009)</sup>	14 <sup>(+0/-0.011)</sup>	14 <sup>(+0/-0.011)</sup>	19 <sup>(+0/-0.013)</sup>	14 <sup>(+0/-0.011)</sup>	14 <sup>(+0/-0.011)</sup>	19 <sup>(+0/-0.013)</sup>
LB	30 <sup>(+0/-0.021)</sup>	50 <sup>(+0/-0.025)</sup>	50 <sup>(+0/-0.025)</sup>	70 <sup>(+0/-0.030)</sup>	50 <sup>(+0/-0.025)</sup>	50 <sup>(+0/-0.025)</sup>	70 <sup>(+0/-0.030)</sup>
LL (w/o brake)	76.2	72.5	91	105.2	69.6	87.45	95.4
LL (with brake)	107.7	104.4	122.9	140.8	101.5	119.35	131
LH	300	300	300	300	300	300	300
LP	300	300	300	300	300	300	300
H	34	44	44	54	44	44	54
LR	25	30	30	35	30	30	35
LE	2.5	3	3	3	3	3	3
LG	5	7.5	7.5	8	7.5	7.5	8
LW	16	20	20	25	20	20	25
RH	6.2	11	11	15.5	11	11	15.5
WK	3	5	5	6	5	5	6
W	3	5	5	6	5	5	6
T	3	5	5	6	5	5	6
TP	M3 Depth 8	M4 Depth 15	M4 Depth 15	M6 Depth 20	M4 Depth 15	M4 Depth 15	M6 Depth 20

Note: refer to Appendix B Accessories for the cables.

Motor frame size: 100 mm (medium inertia)

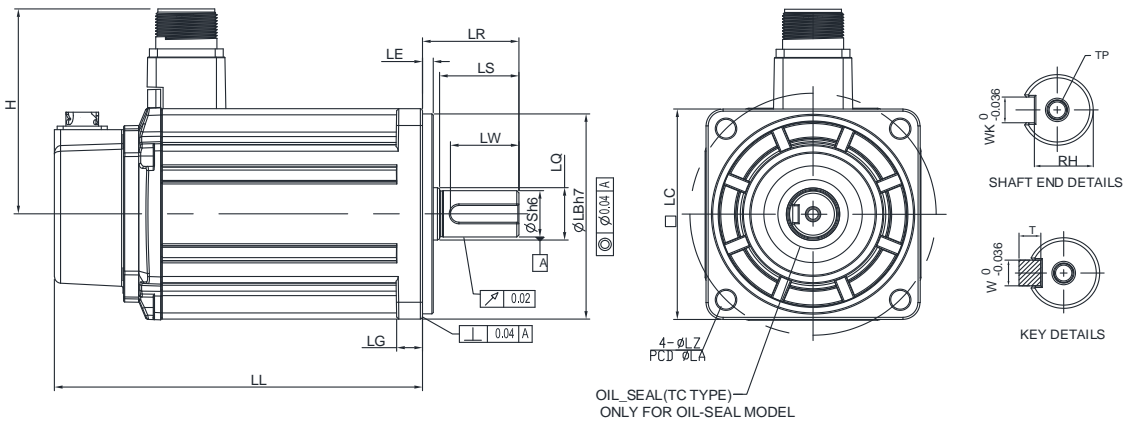

A

ECM-	B3M-C□1010□S1	B3M-C□1015□S1	B3M-C□1020□S1
LC	100	100	100
LZ	9	9	9
LA	115	115	115
S	22 <sup>(+0/-0.013)</sup>	22 <sup>(+0/-0.013)</sup>	22 <sup>(+0/-0.013)</sup>
LB	95 <sup>(+0/-0.03)</sup>	95 <sup>(+0/-0.03)</sup>	95 <sup>(+0/-0.03)</sup>
LL (w/o brake)	141.8	156.8	171.8
LL (with brake)	179.9	194.9	209.9
H	97.4	97.4	97.4
LS	37	37	37
LR	45	45	45
LQ	25	25	25
LE	5	5	5
LG	12	12	12
LW	32	32	32
RH	18	18	18
WK	8	8	8
W	8	8	8
T	7	7	7
TP	M6 Depth 12	M6 Depth 12	M6 Depth 12



Motor frame size: 130 mm (medium & high inertia)

A

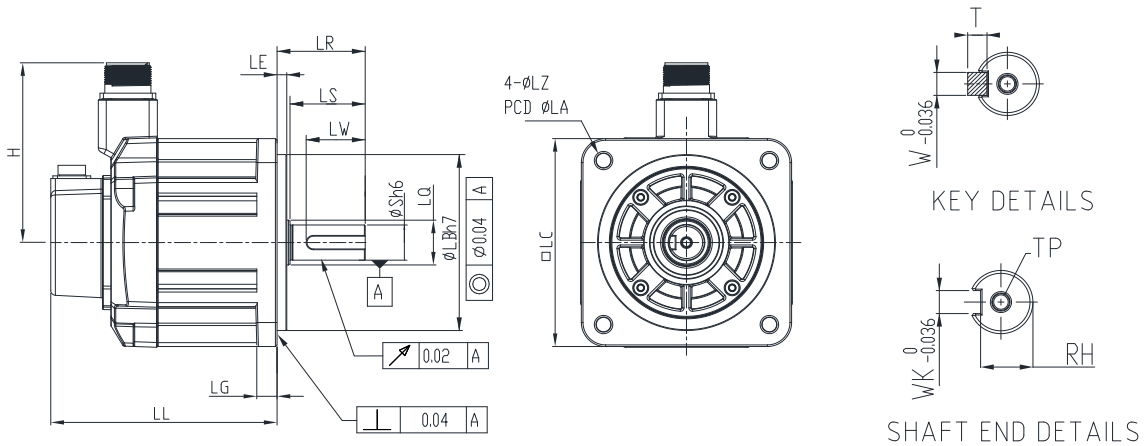

Unit: mm

ECM-	B3M- E□1310□S1	B3M- E□1315□S1	B3M- E□1320□S1	B3H- F□1308□S1	B3H- F□1313□S1	B3H- F□1318□S1
LC	130	130	130	130	130	130
LZ	9	9	9	9	9	9
LA	145	145	145	145	145	145
S	22 <sup>(+0 -0.013)</sup>	22 <sup>(+0 -0.013)</sup>	22 <sup>(+0 -0.013)</sup>	22 <sup>(+0 -0.013)</sup>	22 <sup>(+0 -0.013)</sup>	22 <sup>(+0 -0.013)</sup>
LB	110 <sup>(+0 -0.035)</sup>	110 <sup>(+0 -0.035)</sup>	110 <sup>(+0 -0.035)</sup>	110 <sup>(+0 -0.035)</sup>	110 <sup>(+0 -0.035)</sup>	110 <sup>(+0 -0.035)</sup>
LL (w/o brake)	127.9	139.9	151.9	127.9	139.9	151.9
LL (with brake)	168.5	180.5	192.5	168.5	180.5	192.5
H	115	115	115	115	115	115
LS	47	47	47	47	47	47
LR	55	55	55	55	55	55
LQ	28	28	28	28	28	28
LE	6	6	6	6	6	6
LG	12.5	12.5	12.5	12.5	12.5	12.5
LW	36	36	36	36	36	36
RH	18	18	18	18	18	18
WK	8	8	8	8	8	8
W	8	8	8	8	8	8
T	7	7	7	7	7	7
TP	M6 Depth 12	M6 Depth 12	M6 Depth 12	M6 Depth 12	M6 Depth 12	M6 Depth 12

Motor frame size: 180 mm (medium inertia)

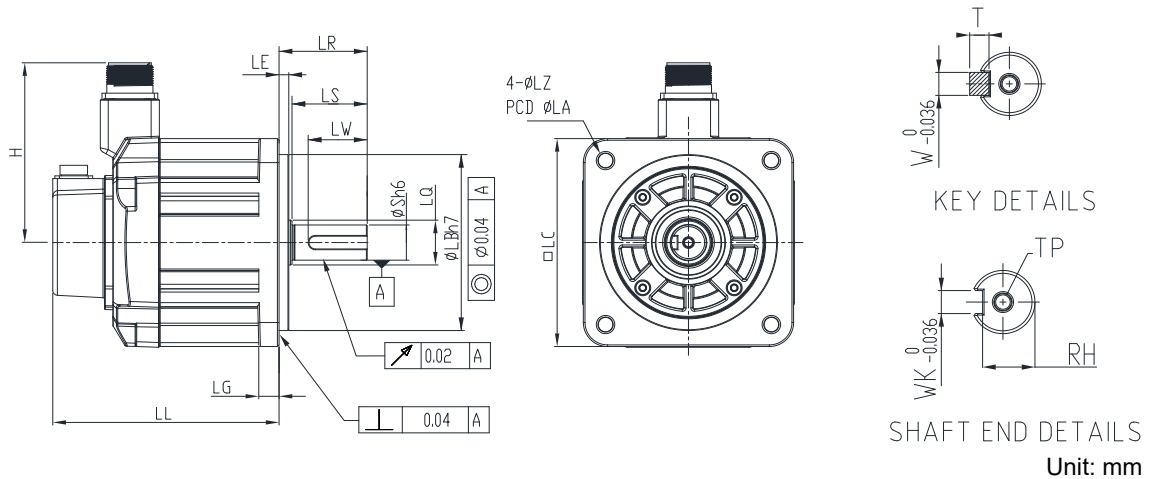

Unit: mm

ECM-	B3M- E□1820□S1	B3M- F□1830□S1	B3M- F□1845□S1	B3M- F□1855□31	B3M- F□1875□31
LC	180	180	180	180	180
LZ	13.5	13.5	13.5	13.5	13.5
LA	200	200	200	200	200
S	35 <sup>(+0/-0.016)</sup>	35 <sup>(+0/-0.016)</sup>	35 <sup>(+0/-0.016)</sup>	42 <sup>(+0/-0.016)</sup>	42 <sup>(+0/-0.016)</sup>
LB	114.3 <sup>(+0/-0.035)</sup>	114.3 <sup>(+0/-0.035)</sup>	114.3 <sup>(+0/-0.035)</sup>	114.3 <sup>(+0/-0.035)</sup>	114.3 <sup>(+0/-0.035)</sup>
LL (w/o brake)	137.5	160.5	174	218	260.1
LL (with brake)	189.5	212.5	226	265	307.1
H	139	139	139	144.5	144.5
LS	73	73	73	108.5	108.5
LR	79	79	79	113	113
LQ	45	45	45	45	45
LE	4	4	4	4	4
LG	18	18	18	18	18
LW	63	63	63	90	90
RH	30	30	30	37	37
WK	10	10	10	12	12
W	10	10	10	12	12
T	8	8	8	8	8
TP	M12 Depth 25	M12 Depth 25	M12 Depth 25	M16 Depth 32	M16 Depth 32

Motor frame size: 220 mm (medium inertia)

A

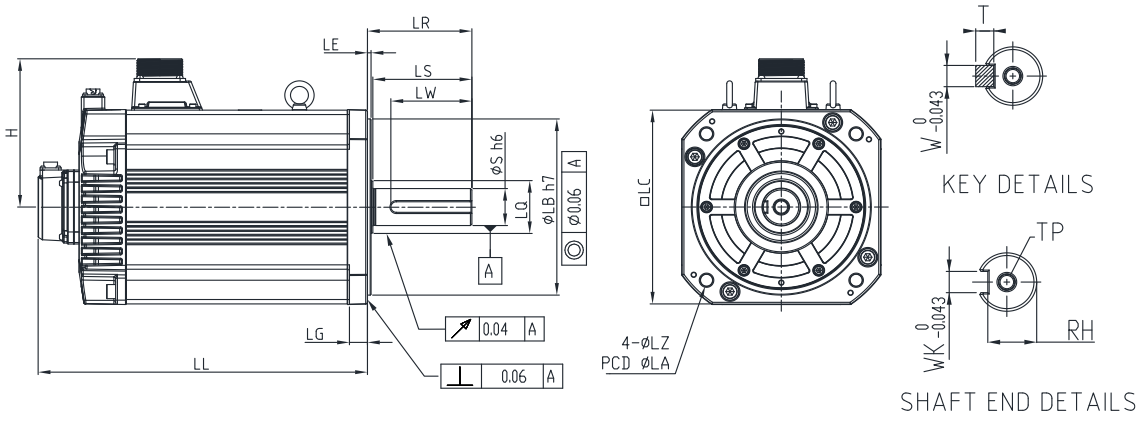

SHAFT END DETAILS  
Unit: mm

ECM-	B3M-F□221B□31	B3M-F□221F□S1
LC	220	220
LZ	13.5	13.5
LA	235	235
S	42 <sup>+0</sup> <sub>-0.016</sub>	55 <sup>+0.03</sup> <sub>-0.011</sub>
LB	200 <sup>+0</sup> <sub>-0.046</sub>	200 <sup>+0</sup> <sub>-0.046</sub>
LL (w/o brake)	331.7	378.7
LL (with brake)	365.6	412.6
H	168.3	168.3
LS	110	110
LR	116	116
LQ	60	60
LE	4	4
LG	20	20
LW	90	90
RH	37	49
WK	12	16
W	12	16
T	8	10
TP	M16 Depth 32	M20 Depth 40

A.3.5.2 400V series

Motor frame size: 80 mm and below, with cables (medium inertia)

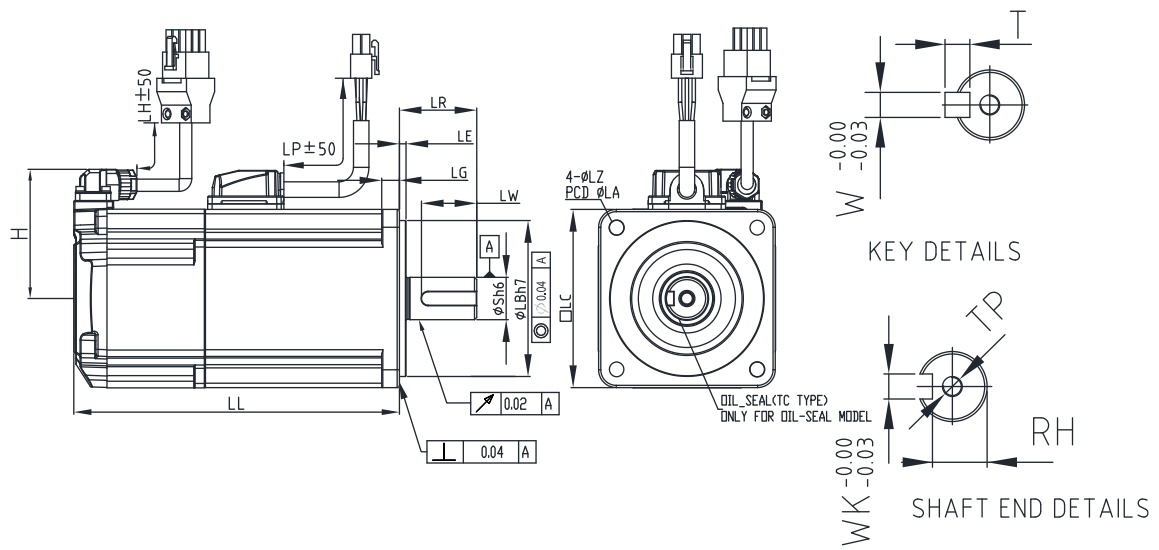

A

Unit: mm

ECM-	B3M-J□0604□S1	B3M-J□0807□S1
LC	60	80
LZ	5.5	6.6
LA	70	90
S	14 <sup>(+0/-0.011)</sup>	19 <sup>(+0/-0.013)</sup>
LB	50 <sup>(+0.000/-0.025)</sup>	70 <sup>(+0.000/-0.030)</sup>
LL (w/o brake)	91	105.2
LL (with brake)	127.9	144.8
LH	300	300
LP	300	300
H	48.5	58.5
LR	30	35
LE	3	3
LG	7.5	8
LW	20	25
RH	11	15.5
WK	5	6
W	5	6
T	5	6
TP	M4 Depth 15	M6 Depth 20

Motor frame size: 100 mm (medium inertia)

A

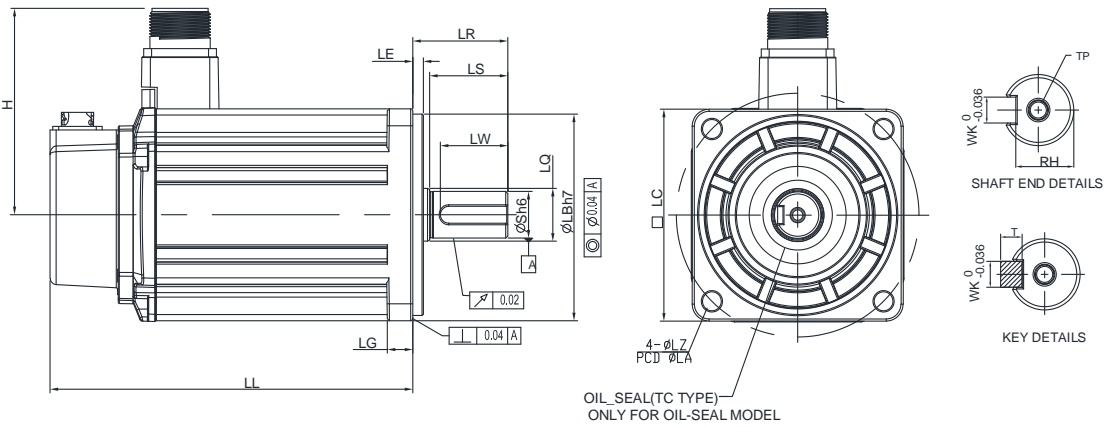

Unit: mm

ECM-	B3M-J□1010□S1	B3M-J□1015□S1	B3M-J□1020□S1
LC	100	100	100
LZ	9	9	9
LA	115	115	115
S	22 <sup>(+0/-0.013)</sup>	22 <sup>(+0/-0.013)</sup>	22 <sup>(+0/-0.013)</sup>
LB	95 <sup>(+0/-0.03)</sup>	95 <sup>(+0/-0.03)</sup>	95 <sup>(+0/-0.03)</sup>
LL (w/o brake)	141.8	156.8	171.8
LL (with brake)	179.9	194.9	209.9
H	97.4	97.4	97.4
LS	37	37	37
LR	45	45	45
LQ	25	25	25
LE	5	5	5
LG	12	12	12
LW	32	32	32
RH	18	18	18
WK	8	8	8
W	8	8	8
T	7	7	7
TP	M6 Depth 12	M6 Depth 12	M6 Depth 12

Motor frame size: 130 mm (medium & high inertia)

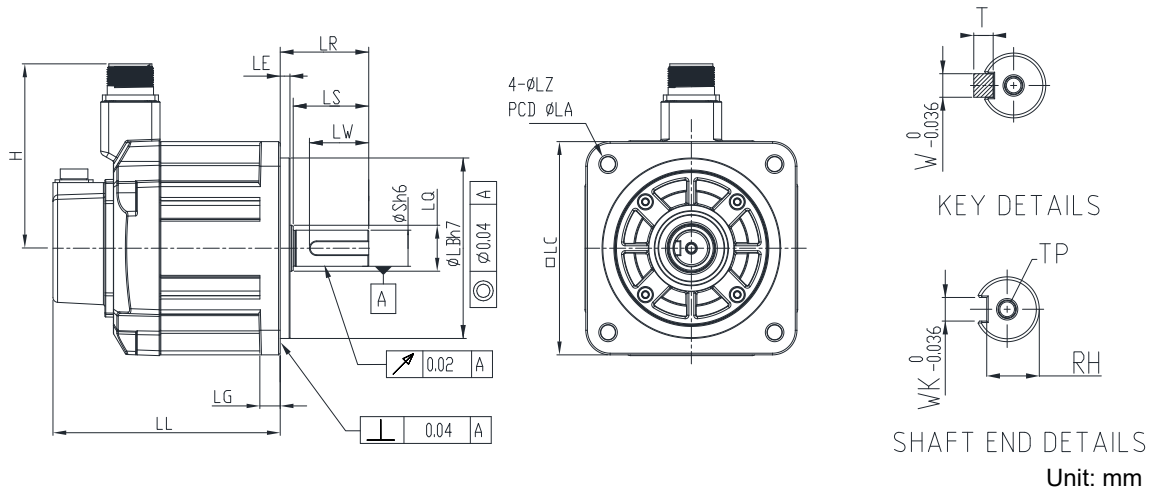

ECM-	B3M-K□1310□S1	B3M-K□1315□S1	B3M-K□1320□S1	B3H-L□1308□S1	B3H-L□1313□S1	B3H-L□1318□S1
LC	130	130	130	130	130	130
LZ	9	9	9	9	9	9
LA	145	145	145	145	145	145
S	22 <sup>(+0/-0.013)</sup>	22 <sup>(+0/-0.013)</sup>	22 <sup>(+0/-0.013)</sup>	22 <sup>(+0/-0.013)</sup>	22 <sup>(+0/-0.013)</sup>	22 <sup>(+0/-0.013)</sup>
LB	110 <sup>(+0/-0.035)</sup>	110 <sup>(+0/-0.035)</sup>	110 <sup>(+0/-0.035)</sup>	110 <sup>(+0/-0.035)</sup>	110 <sup>(+0/-0.035)</sup>	110 <sup>(+0/-0.035)</sup>
LL (w/o brake)	127.9	139.9	151.9	127.9	139.9	151.9
LL (with brake)	168.5	180.5	192.5	168.5	180.5	192.5
H	115	115	115	115	115	115
LS	47	47	47	47	47	47
LR	55	55	55	55	55	55
LQ	28	28	28	28	28	28
LE	6	6	6	6	6	6
LG	12.5	12.5	12.5	12.5	12.5	12.5
LW	36	36	36	36	36	36
RH	18	18	18	18	18	18
WK	8	8	8	8	8	8
W	8	8	8	8	8	8
T	7	7	7	7	7	7
TP	M6 Depth 12	M6 Depth 12	M6 Depth 12	M6 Depth 12	M6 Depth 12	M6 Depth 12

Motor frame size: 180 mm (medium inertia)

A

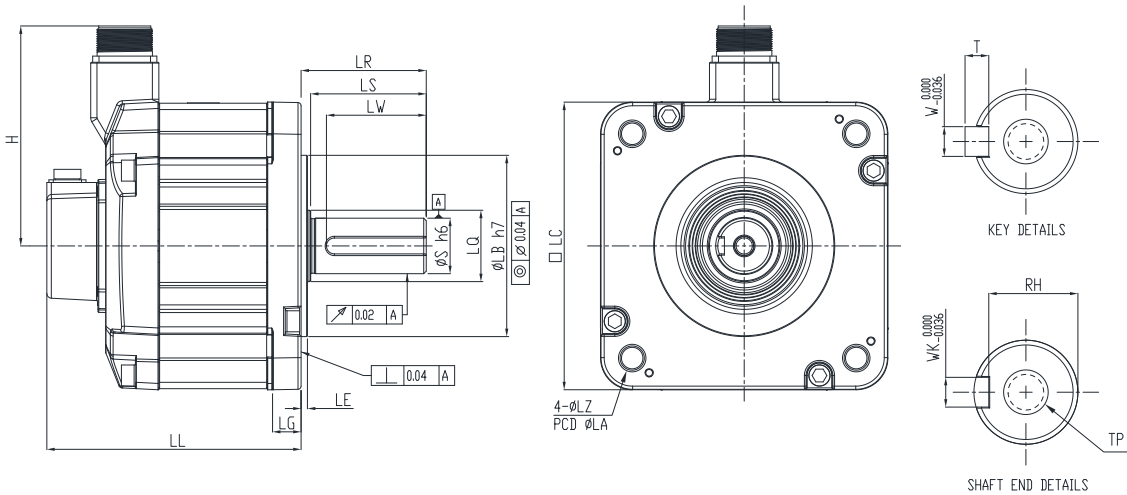

Unit: mm

ECM-	B3M-K□1820□S1	B3M-L□1830□S1	B3M-L□1845□S1	B3M-L□1855□S1	B3M-L□1875□S1
LC	180	180	180	180	180
LZ	13.5	13.5	13.5	13.5	13.5
LA	200	200	200	200	200
S	35 <sup>(+0)</sup> <sub>(-0.016)</sub>	35 <sup>(+0)</sup> <sub>(-0.016)</sub>	35 <sup>(+0)</sup> <sub>(-0.016)</sub>	42 <sup>(+0)</sup> <sub>(-0.016)</sub>	42 <sup>(+0)</sup> <sub>(-0.016)</sub>
LB	114.3 <sup>(+0)</sup> <sub>(-0.035)</sub>	114.3 <sup>(+0)</sup> <sub>(-0.035)</sub>	114.3 <sup>(+0)</sup> <sub>(-0.035)</sub>	114.3 <sup>(+0)</sup> <sub>(-0.035)</sub>	114.3 <sup>(+0)</sup> <sub>(-0.035)</sub>
LL (w/o brake)	137.5	160.5	174	218	260.1
LL (with brake)	189.5	212.5	226	265	307.1
H	139	139	139	144.5	144.5
LS	73	73	73	108.5	108.5
LR	79	79	79	113	113
LQ	45	45	45	45	45
LE	4	4	4	4	4
LG	18	18	18	18	18
LW	63	63	63	90	90
RH	30	30	30	37	37
WK	10	10	10	12	12
W	10	10	10	12	12
T	8	8	8	8	8
TP	M12 Depth 25	M12 Depth 25	M12 Depth 25	M16 Depth 32	M16 Depth 32

Motor frame size: 220 mm (medium inertia)

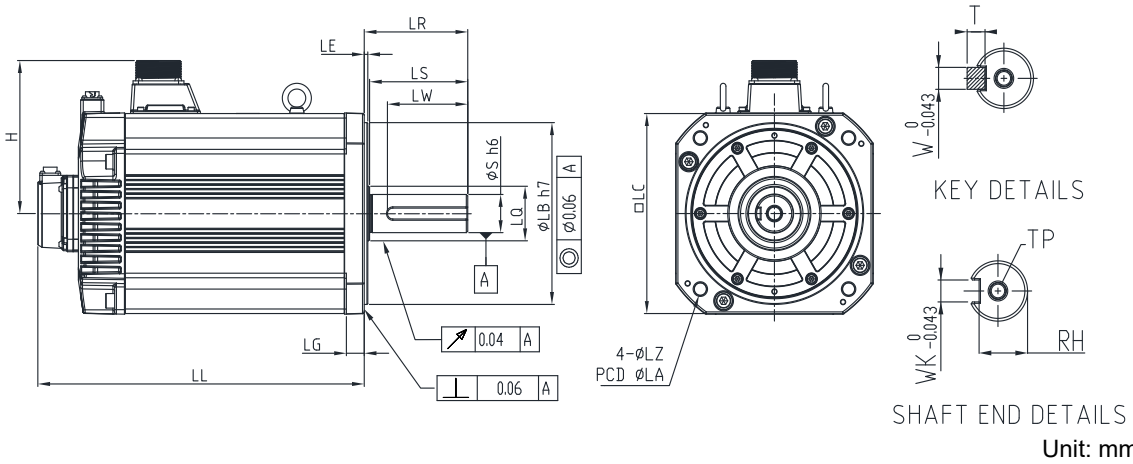

A

Unit: mm

ECM-	B3M-L□221B□31	B3M-L□221F□S1
LC	220	220
LZ	13.5	13.5
LA	235	235
S	42 <sup>(+0)</sup> <sub>(-0.016)</sub>	55 <sup>(+0.03)</sup> <sub>(-0.011)</sub>
LB	200 <sup>(+0)</sup> <sub>(-0.046)</sub>	200 <sup>(+0)</sup> <sub>(-0.046)</sub>
LL (w/o brake)	331.7	378.7
LL (with brake)	365.6	412.6
H	168.3	168.3
LS	110	110
LR	116	116
LQ	60	60
LE	4	4
LG	20	20
LW	90	90
RH	37	49
WK	12	16
W	12	16
T	8	10
TP	M16 Depth 32	M20 Depth 40



(This page is intentionally left blank.)

A

# Accessories

# Appendix

# B

This chapter provides information for choosing the suitable accessories.

B.1	Power connector	B-3
B.1.1	F40 - F80 motors	B-3
B.1.2	F100 - F130 motors	B-5
B.1.3	F180 4.5 kW (or below) motors	B-6
B.1.4	F180 5.5 kW (or above) and F220 motors	B-7
B.1.5	Brake connector for F100 - F220 motors	B-8
B.2	Power cable	B-9
B.2.1	F40 - F80 motors	B-9
B.2.2	F100 - F130 motors	B-14
B.2.3	F180 4.5 kW (or below) motors	B-16
B.2.4	F180 5.5 kW (or above) and F220 motors	B-18
B.2.5	Brake cable for F100 - F220 motors	B-20
B.3	Encoder connector	B-22
B.3.1	F40 - F80 motors	B-22
B.3.2	F100 - F220 motors	B-23
B.4	Encoder cable (incremental type)	B-24
B.4.1	F40 - F80 motors	B-24
B.4.2	F100 - F220 motors	B-26
B.5	Encoder cable (absolute type)	B-28
B.5.1	F40 - F80 motors	B-28
B.5.2	F100 - F220 motors	B-30
B.6	Battery box cable	B-32
B.7	Battery box	B-33
B.8	CN1 connector	B-34
B.9	CN1 quick connector	B-35
B.10	CN1 terminal block module	B-36
B.11	CANopen communication cable	B-38
B.12	CANopen distribution box	B-38
B.13	Ferrite ring	B-39
B.14	A3 / A2 conversion cable	B-39
B.15	CN3 RS-485 splitter	B-40
B.16	CN3 RS-485 / CANopen terminal resistor	B-40

B.17 CN4 Mini USB communication module ..... B-41

B.18 Position signal converter box..... B-42

B.19 Optional accessories ..... B-43

    220V models ..... B-43

        F40 - F80 motors ..... B-43

        F100 - F130 motors..... B-44

        F180 4.5 kW (or below) motors ..... B-45

        F180 5.5 kW (or above) and F220 motors ..... B-46

    400V models ..... B-47

        F40 - F80 motors ..... B-47

        F100 - F130 motors..... B-48

        F180 4.5 kW (or below) motors ..... B-49

        F180 5.5 kW (or above) and F220 motors ..... B-50

B

## B.1 Power connector

### B.1.1 F40 - F80 motors

**Standard connector for A3 / B3 non-brake motors (applicable to 220V and 400V models)**

Delta model number: ACS3-CAPW1000

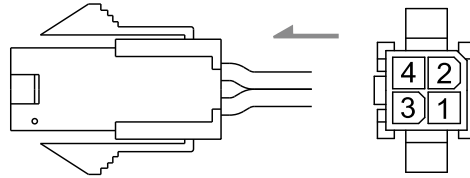

**CHOGORI connector for A3 / B3 non-brake motors (applicable to 220V models)**

Delta model number: ACS3-CNPW1A00

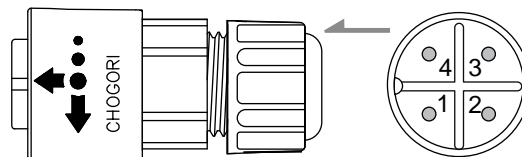

Note: refer to Section 3.1.7 Waterproof connector wiring instructions for more information.

**Standard connector for A3 / B3 brake motors (applicable to 220V and 400V models)**

Delta model number: ACS3-CAPW2000

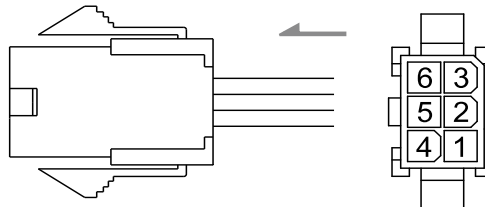

**CHOGORI connector for A3 / B3 brake motors (applicable to 220V models)**

Delta model number: ACS3-CNPW2A00

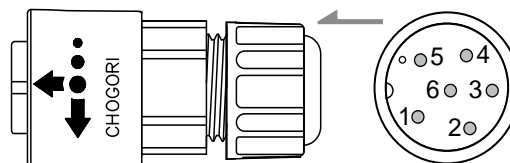

Note: refer to Section 3.1.7 Waterproof connector wiring instructions for more information.

B

B

**Bulkhead connector (cable exit direction towards motor shaft) for B3 brake & non-brake motors (applicable to 220V and 400V models)**

Delta model number: ACS3-AFPWSS00

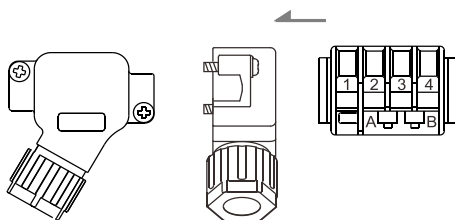

Note: refer to Section 3.1.7 Waterproof connector wiring instructions for more information.

**Bulkhead connector (cable exit direction towards encoder) for B3 brake & non-brake motors (applicable to 220V and 400V models)**

Delta model number: ACS3-ABPWSS00

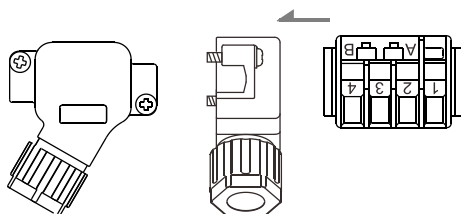

Note: refer to Section 3.1.7 Waterproof connector wiring instructions for more information.

## B.1.2 F100 - F130 motors

### Straight military connector for B3 non-brake motors (applicable to 220V and 400V models)

Delta model number: ACS3-CAPWA000

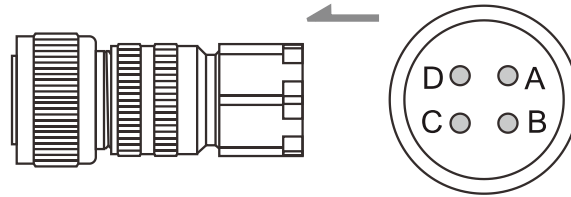

Note:

1. Refer to Section 3.1.7 Waterproof connector wiring instructions for more information.
2. For the B3 series brake motors, you need to purchase this connector and the brake connector for F100 - F220 motors listed in Section B.1.5.

### Right angle military connector for B3 non-brake motors (applicable to 220V and 400V models)

Delta model number: ACS3-CRPWA000

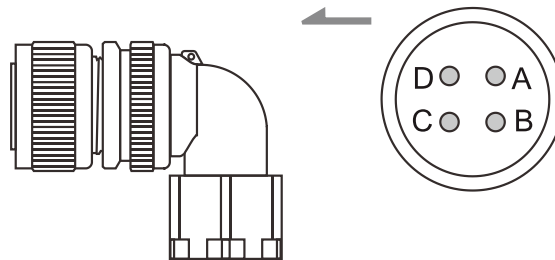

Note:

1. Refer to Section 3.1.7 Waterproof connector wiring instructions for more information.
2. For the B3 series brake motors, you need to purchase this connector and the brake connector for F100 - F220 motors listed in Section B.1.5.

# B

### B.1.3 F180 4.5 kW (or below) motors

#### Straight military connector for B3 non-brake motors (applicable to 220V and 400V models)

Delta model number: ACS3-CAPWC000

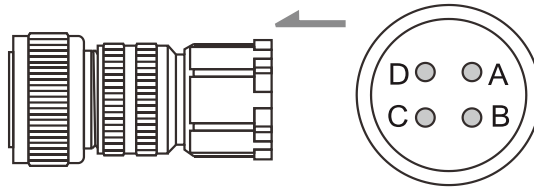

Note:

1. Refer to Section 3.1.7 Waterproof connector wiring instructions for more information.
2. For the B3 series brake motors, you need to purchase this connector and the brake connector for F100 - F220 motors listed in Section B.1.5.

#### Right angle military connector for B3 non-brake motors (applicable to 220V and 400V models)

Delta model number: ACS3-CRPWC000

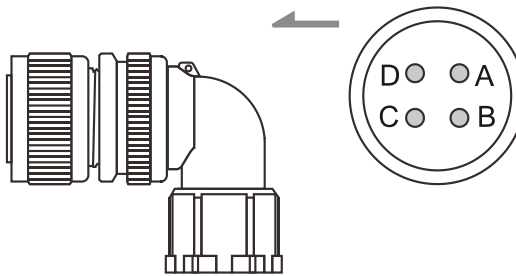

Note:

1. Refer to Section 3.1.7 Waterproof connector wiring instructions for more information.
2. For the B3 series brake motors, you need to purchase this connector and the brake connector for F100 - F220 motors listed in Section B.1.5.

# B

### B.1.4 F180 5.5 kW (or above) and F220 motors

#### Straight military connector for B3 non-brake motors (applicable to 220V and 400V models)

Delta model number: ACS3-CAPWE000

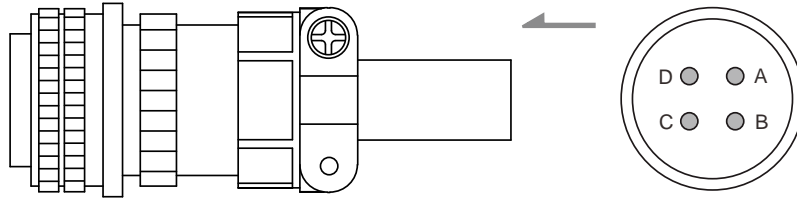

Note:

1. Refer to Section 3.1.7 Waterproof connector wiring instructions for more information.
2. For the B3 series brake motors, you need to purchase this connector and the brake connector for F100 - F220 motors listed in Section B.1.5.

#### Right angle military connector for B3 non-brake motors (applicable to 220V and 400V models)

Delta model number: ACS3-CRPWE000

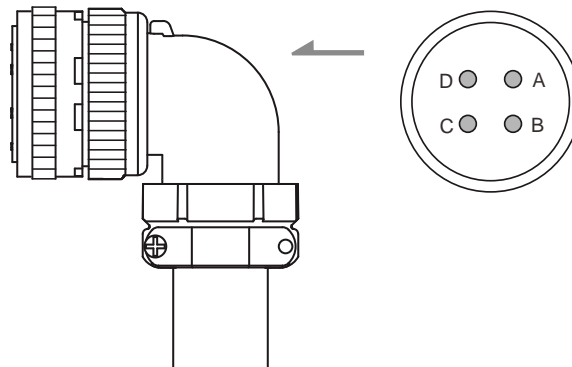

Note:

1. Refer to Section 3.1.7 Waterproof connector wiring instructions for more information.
2. For the B3 series brake motors, you need to purchase this connector and the brake connector for F100 - F220 motors listed in Section B.1.5.

# B



B

**B.1.5 Brake connector for F100 - F220 motors**

- Use bayonet connectors for motors with bayonet or threaded bayonet connectors.
- Use threaded connectors for motors with threaded bayonet connectors.

**Straight military connector (bayonet) for B3 brake motors (applicable to 220V and 400V models)**

Delta model number: ACS3-CABRA000

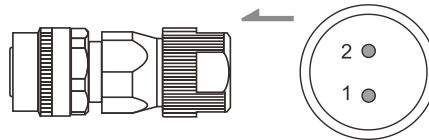

Note: refer to Section 3.1.7 Waterproof connector wiring instructions for more information.

**Straight military connector (threaded, M17.5) for B3 brake motors (applicable to 220V and 400V models)**

Delta model number: ACS3-CABRM000

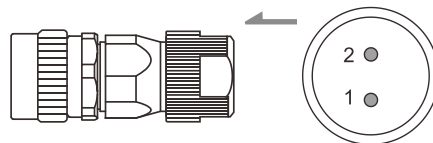

Note: refer to Section 3.1.7 Waterproof connector wiring instructions for more information.

**Right angle military connector (bayonet) for B3 brake motors (applicable to 220V and 400V models)**

Delta model number: ACS3-CRBRA000

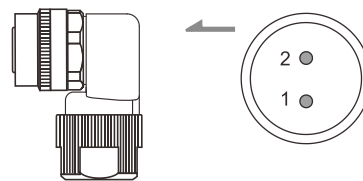

Note: refer to Section 3.1.7 Waterproof connector wiring instructions for more information.

**Right angle military connector (threaded, M17.5) for B3 brake motors (applicable to 220V and 400V models)**

Delta model number: ACS3-CRBRM000

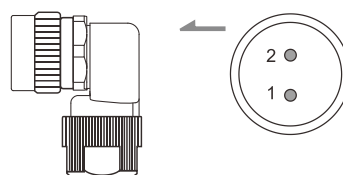

Note: refer to Section 3.1.7 Waterproof connector wiring instructions for more information.

## B.2 Power cable

### B.2.1 F40 - F80 motors

Cable with standard connector for A3 / B3 non-brake motors (applicable to 220V models)

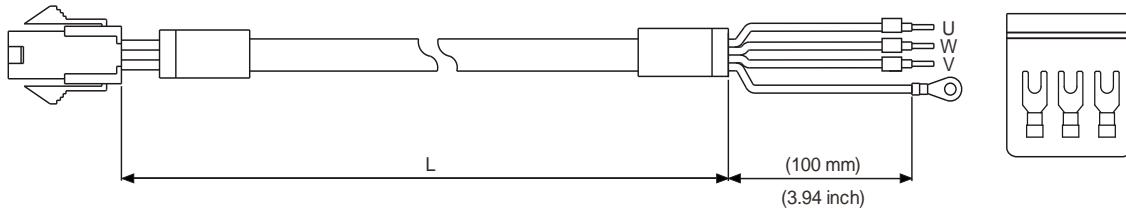

Cable type	Model number	UVW wire diameter	L	
		AWG (mm <sup>2</sup> )	mm	inch
Standard	ACS3-CAPW1103	18 (0.82)	3000 ± 50	118 ± 2
	ACS3-CAPW1105	18 (0.82)	5000 ± 50	197 ± 2
	ACS3-CAPW1110	18 (0.82)	10000 ± 100	394 ± 4
	ACS3-CAPW1120	18 (0.82)	20000 ± 100	787 ± 4
Flexible	ACS3-CAPF1103	18 (0.82)	3000 ± 50	118 ± 2
	ACS3-CAPF1105	18 (0.82)	5000 ± 50	197 ± 2
	ACS3-CAPF1110	18 (0.82)	10000 ± 100	394 ± 4
	ACS3-CAPF1120	18 (0.82)	20000 ± 100	787 ± 4

Cable with standard connector for A3 / B3 non-brake motors (applicable to 400V models)

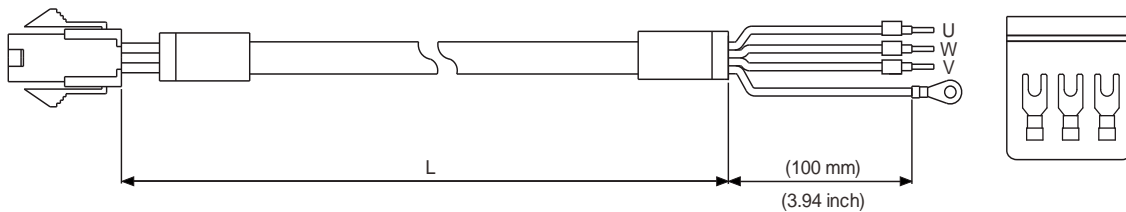

Cable type	Model number	UVW wire diameter	L	
		AWG (mm <sup>2</sup> )	mm	inch
Standard	ACS3-CAPW3103	18 (0.82)	3000 ± 50	118 ± 2
	ACS3-CAPW3105	18 (0.82)	5000 ± 50	197 ± 2
	ACS3-CAPW3110	18 (0.82)	10000 ± 100	394 ± 4
	ACS3-CAPW3120	18 (0.82)	20000 ± 100	787 ± 4
Flexible	ACS3-CAPF3103	18 (0.82)	3000 ± 50	118 ± 2
	ACS3-CAPF3105	18 (0.82)	5000 ± 50	197 ± 2
	ACS3-CAPF3110	18 (0.82)	10000 ± 100	394 ± 4
	ACS3-CAPF3120	18 (0.82)	20000 ± 100	787 ± 4

B

B

**Cable with CHOGORI connector for A3 / B3 non-brake motors (applicable to 220V models)**

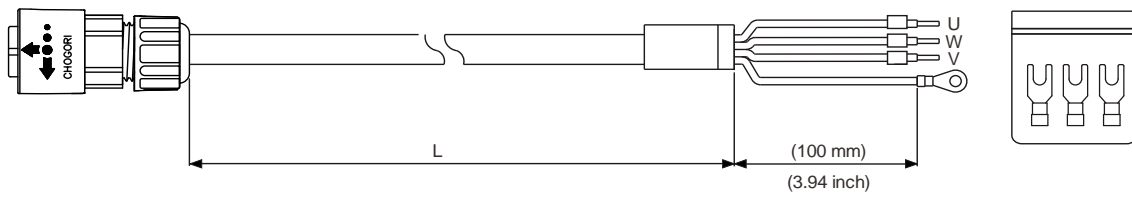

Cable type	Model number	UVW wire diameter	L	
		AWG (mm <sup>2</sup> )	mm	inch
Standard	ACS3-CAPW5103	18 (0.82)	3000 ± 50	118 ± 2
	ACS3-CAPW5105	18 (0.82)	5000 ± 50	197 ± 2
	ACS3-CAPW5110	18 (0.82)	10000 ± 100	394 ± 4
	ACS3-CAPW5120	18 (0.82)	20000 ± 100	787 ± 4
Flexible	ACS3-CAPF5103	18 (0.82)	3000 ± 50	118 ± 2
	ACS3-CAPF5105	18 (0.82)	5000 ± 50	197 ± 2
	ACS3-CAPF5110	18 (0.82)	10000 ± 100	394 ± 4
	ACS3-CAPF5120	18 (0.82)	20000 ± 100	787 ± 4

**Cable with bulkhead connector (cable exit direction towards motor shaft) for B3 non-brake motors (applicable to 220V models)**

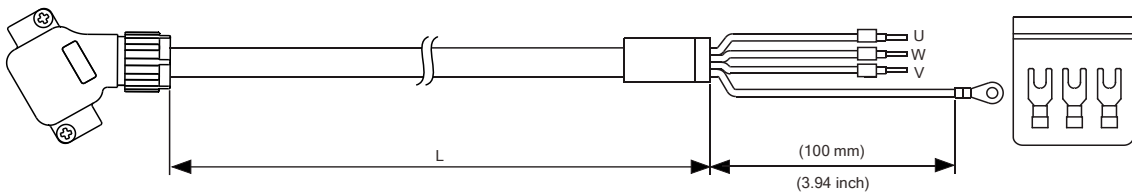

Cable type	Model number	UVW wire diameter	L	
		AWG (mm <sup>2</sup> )	mm	inch
Standard	ACS3-AFPWSR03	20 (0.52)	3000 ± 50	118 ± 2
	ACS3-AFPWSR05	20 (0.52)	5000 ± 50	197 ± 2
	ACS3-AFPWSR10	20 (0.52)	10000 ± 100	394 ± 4
	ACS3-AFPWSR20	20 (0.52)	20000 ± 100	787 ± 4
Flexible	ACS3-AFPRSR03	20 (0.52)	3000 ± 50	118 ± 2
	ACS3-AFPRSR05	20 (0.52)	5000 ± 50	197 ± 2
	ACS3-AFPRSR10	20 (0.52)	10000 ± 100	394 ± 4
	ACS3-AFPRSR20	20 (0.52)	20000 ± 100	787 ± 4

**Cable with bulkhead connector (cable exit direction towards encoder) for B3 non-brake motors (applicable to 220V models)**

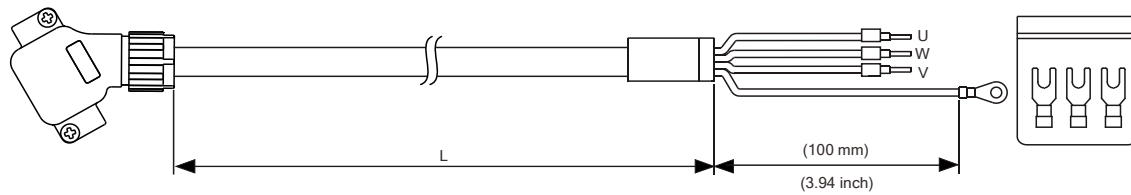

B

Cable type	Model number	UVW wire diameter	L	
		AWG (mm <sup>2</sup> )	mm	inch
Standard	ACS3-ABPWSR03	20 (0.52)	3000 ± 50	118 ± 2
	ACS3-ABPWSR05	20 (0.52)	5000 ± 50	197 ± 2
	ACS3-ABPWSR10	20 (0.52)	10000 ± 100	394 ± 4
	ACS3-ABPWSR20	20 (0.52)	20000 ± 100	787 ± 4
Flexible	ACS3-ABPRSR03	20 (0.52)	3000 ± 50	118 ± 2
	ACS3-ABPRSR05	20 (0.52)	5000 ± 50	197 ± 2
	ACS3-ABPRSR10	20 (0.52)	10000 ± 100	394 ± 4
	ACS3-ABPRSR20	20 (0.52)	20000 ± 100	787 ± 4

**Cable with standard connector for A3 / B3 brake motors (applicable to 220V and 400V models)**

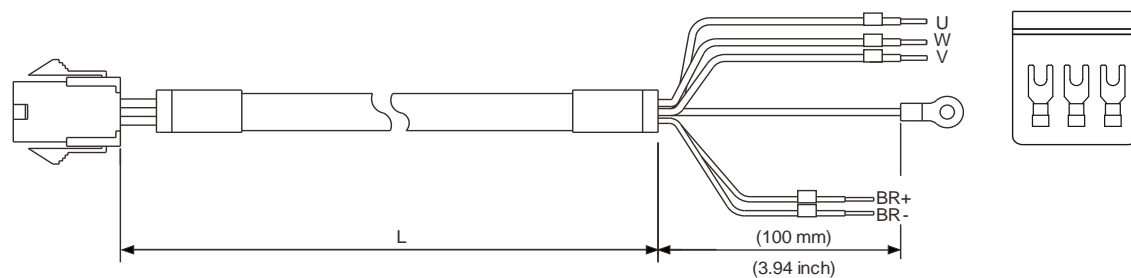

Cable type	Model number	UVW wire diameter	Brake wire diameter	L	
		AWG (mm <sup>2</sup> )		mm	inch
Standard	ACS3-CAPW2103	18 (0.82)	22 (0.32)	3000 ± 50	118 ± 2
	ACS3-CAPW2105	18 (0.82)	22 (0.32)	5000 ± 50	197 ± 2
	ACS3-CAPW2110	18 (0.82)	22 (0.32)	10000 ± 100	394 ± 4
	ACS3-CAPW2120	18 (0.82)	22 (0.32)	20000 ± 100	787 ± 4
Flexible	ACS3-CAPF2103	18 (0.82)	22 (0.32)	3000 ± 50	118 ± 2
	ACS3-CAPF2105	18 (0.82)	22 (0.32)	5000 ± 50	197 ± 2
	ACS3-CAPF2110	18 (0.82)	22 (0.32)	10000 ± 100	394 ± 4
	ACS3-CAPF2120	18 (0.82)	22 (0.32)	20000 ± 100	787 ± 4

B

**Cable with CHOGORI connector for A3 / B3 brake motors (applicable to 220V models)**

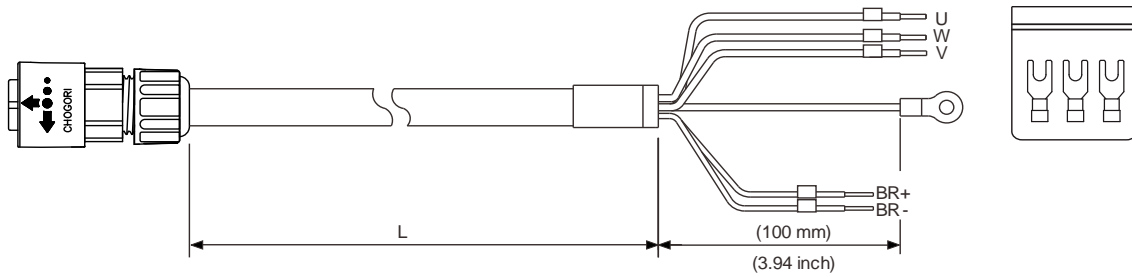

Cable type	Model number	UVW wire diameter	Brake wire diameter	L	
		AWG (mm <sup>2</sup> )		mm	inch
Standard	ACS3-CAPW6103	18 (0.82)	22 (0.32)	3000 ± 50	118 ± 2
	ACS3-CAPW6105	18 (0.82)	22 (0.32)	5000 ± 50	197 ± 2
	ACS3-CAPW6110	18 (0.82)	22 (0.32)	10000 ± 100	394 ± 4
	ACS3-CAPW6120	18 (0.82)	22 (0.32)	20000 ± 100	787 ± 4
Flexible	ACS3-CAPF6103	18 (0.82)	22 (0.32)	3000 ± 50	118 ± 2
	ACS3-CAPF6105	18 (0.82)	22 (0.32)	5000 ± 50	197 ± 2
	ACS3-CAPF6110	18 (0.82)	22 (0.32)	10000 ± 100	394 ± 4
	ACS3-CAPF6120	18 (0.82)	22 (0.32)	20000 ± 100	787 ± 4

**Cable with bulkhead connector (cable exit direction towards motor shaft) for B3 brake motors (applicable to 220V models)**

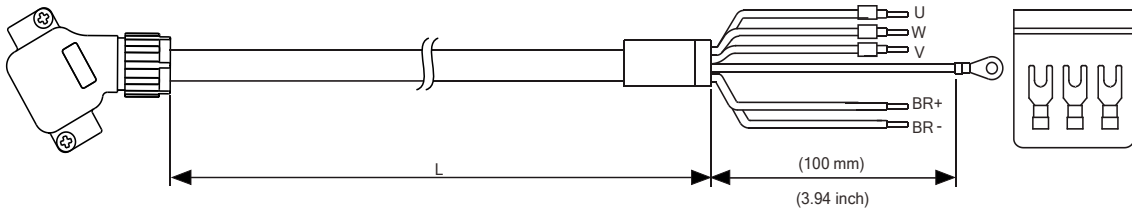

Cable type	Model number	UVW wire diameter	Brake wire diameter	L	
		AWG (mm <sup>2</sup> )		mm	inch
Standard	ACS3-AFPWSS03	20 (0.52)	24 (0.21)	3000 ± 50	118 ± 2
	ACS3-AFPWSS05	20 (0.52)	24 (0.21)	5000 ± 50	197 ± 2
	ACS3-AFPWSS10	20 (0.52)	24 (0.21)	10000 ± 100	394 ± 4
	ACS3-AFPWSS20	20 (0.52)	24 (0.21)	20000 ± 100	787 ± 4
Flexible	ACS3-AFPRSS03	20 (0.52)	24 (0.21)	3000 ± 50	118 ± 2
	ACS3-AFPRSS05	20 (0.52)	24 (0.21)	5000 ± 50	197 ± 2
	ACS3-AFPRSS10	20 (0.52)	24 (0.21)	10000 ± 100	394 ± 4
	ACS3-AFPRSS20	20 (0.52)	24 (0.21)	20000 ± 100	787 ± 4

**Cable with bulkhead connector (cable exit direction towards encoder) for B3 brake motors  
(applicable to 220V models)**

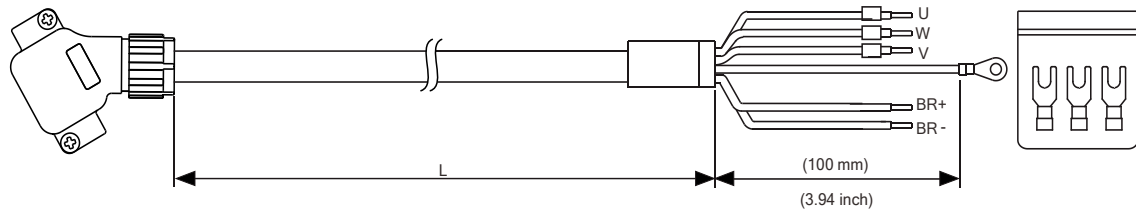

B

Cable type	Model number	UVW wire diameter	Brake wire diameter	L	
		AWG (mm <sup>2</sup> )		mm	inch
Standard	ACS3-ABPWSS03	20 (0.52)	24 (0.21)	3000 ± 50	118 ± 2
	ACS3-ABPWSS05	20 (0.52)	24 (0.21)	5000 ± 50	197 ± 2
	ACS3-ABPWSS10	20 (0.52)	24 (0.21)	10000 ± 100	394 ± 4
	ACS3-ABPWSS20	20 (0.52)	24 (0.21)	20000 ± 100	787 ± 4
Flexible	ACS3-ABPRSS03	20 (0.52)	24 (0.21)	3000 ± 50	118 ± 2
	ACS3-ABPRSS05	20 (0.52)	24 (0.21)	5000 ± 50	197 ± 2
	ACS3-ABPRSS10	20 (0.52)	24 (0.21)	10000 ± 100	394 ± 4
	ACS3-ABPRSS20	20 (0.52)	24 (0.21)	20000 ± 100	787 ± 4

**B.2.2 F100 - F130 motors**

**Cable with straight military connector for B3 non-brake motors (applicable to 220V and 400V models)**

B

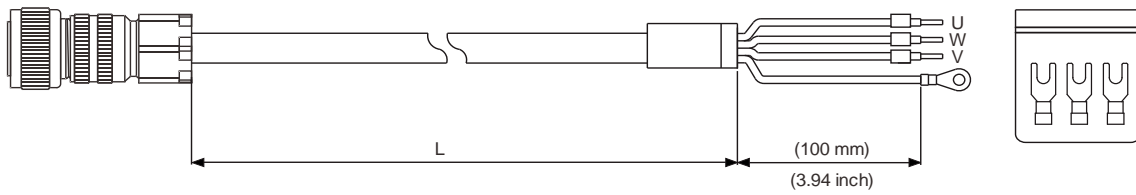

Cable type	Model number	Connector	Wire diameter	L		
			AWG (mm <sup>2</sup> )	mm	inch	
Standard	ACS3-CAPWA203	3106A-18-10S	16 (1.3)	3000 ± 50	118 ± 2	
	ACS3-CAPWA205		16 (1.3)	5000 ± 50	197 ± 2	
	ACS3-CAPWA210		16 (1.3)	10000 ± 100	394 ± 4	
	ACS3-CAPWA220		16 (1.3)	20000 ± 100	787 ± 4	
	ACS3-CAPWA303		14 (2.1)	3000 ± 50	118 ± 2	
	ACS3-CAPWA305		14 (2.1)	5000 ± 50	197 ± 2	
	ACS3-CAPWA310		14 (2.1)	10000 ± 100	394 ± 4	
	ACS3-CAPWA320		14 (2.1)	20000 ± 100	787 ± 4	
Flexible	ACS3-CAPFA203		3106A-18-10S	16 (1.3)	3000 ± 50	118 ± 2
	ACS3-CAPFA205			16 (1.3)	5000 ± 50	197 ± 2
	ACS3-CAPFA210			16 (1.3)	10000 ± 100	394 ± 4
	ACS3-CAPFA220			16 (1.3)	20000 ± 100	787 ± 4
	ACS3-CAPFA303			14 (2.1)	3000 ± 50	118 ± 2
	ACS3-CAPFA305			14 (2.1)	5000 ± 50	197 ± 2
	ACS3-CAPFA310			14 (2.1)	10000 ± 100	394 ± 4
	ACS3-CAPFA320			14 (2.1)	20000 ± 100	787 ± 4

Note: brake cables are sold separately. Refer to Section B.2.5.

**Cable with right angle military connector for B3 non-brake motors (applicable to 220V and 400V models)**

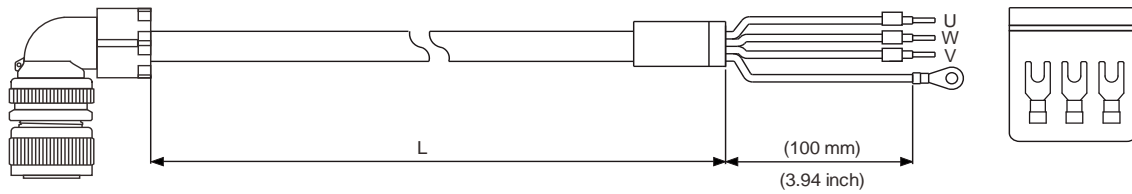

B

Cable type	Model number	Connector	Wire diameter	L	
			AWG (mm <sup>2</sup> )	mm	inch
Standard	ACS3-CRPWA203	3108A-18-10S	16 (1.3)	3000 ± 50	118 ± 2
	ACS3-CRPWA205		16 (1.3)	5000 ± 50	197 ± 2
	ACS3-CRPWA210		16 (1.3)	10000 ± 100	394 ± 4
	ACS3-CRPWA220		16 (1.3)	20000 ± 100	787 ± 4
	ACS3-CRPWA303		14 (2.1)	3000 ± 50	118 ± 2
	ACS3-CRPWA305		14 (2.1)	5000 ± 50	197 ± 2
	ACS3-CRPWA310		14 (2.1)	10000 ± 100	394 ± 4
	ACS3-CRPWA320		14 (2.1)	20000 ± 100	787 ± 4
Flexible	ACS3-CRPFA203		16 (1.3)	3000 ± 50	118 ± 2
	ACS3-CRPFA205		16 (1.3)	5000 ± 50	197 ± 2
	ACS3-CRPFA210		16 (1.3)	10000 ± 100	394 ± 4
	ACS3-CRPFA220		16 (1.3)	20000 ± 100	787 ± 4
	ACS3-CRPFA303		14 (2.1)	3000 ± 50	118 ± 2
	ACS3-CRPFA305		14 (2.1)	5000 ± 50	197 ± 2
	ACS3-CRPFA310		14 (2.1)	10000 ± 100	394 ± 4
	ACS3-CRPFA320		14 (2.1)	20000 ± 100	787 ± 4

Note: brake cables are sold separately. Refer to Section B.2.5.



### B.2.3 F180 4.5 kW (or below) motors

Cable with straight military connector for B3 non-brake motors (applicable to 220V and 400V models)

B

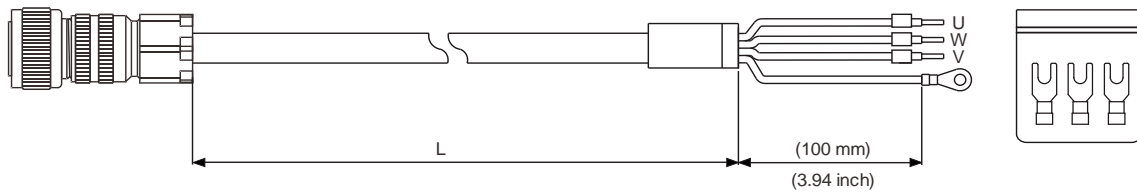

Cable type	Model number	Connector	Wire diameter	L	
			AWG (mm <sup>2</sup> )	mm	inch
Standard	ACS3-CAPWC303	3106A-22-22S	14 (2.1)	3000 ± 50	118 ± 2
	ACS3-CAPWC305		14 (2.1)	5000 ± 50	197 ± 2
	ACS3-CAPWC310		14 (2.1)	10000 ± 100	394 ± 4
	ACS3-CAPWC320		14 (2.1)	20000 ± 100	787 ± 4
	ACS3-CAPWC403		12 (3.3)	3000 ± 50	118 ± 2
	ACS3-CAPWC405		12 (3.3)	5000 ± 50	197 ± 2
	ACS3-CAPWC410		12 (3.3)	10000 ± 100	394 ± 4
	ACS3-CAPWC420		12 (3.3)	20000 ± 100	787 ± 4
	ACS3-CAPWC503		10 (5.3)	3000 ± 50	118 ± 2
	ACS3-CAPWC505		10 (5.3)	5000 ± 50	197 ± 2
	ACS3-CAPWC510		10 (5.3)	10000 ± 100	394 ± 4
	ACS3-CAPWC520		10 (5.3)	20000 ± 100	787 ± 4
	ACS3-CAPWC603		8 (8.4)	3000 ± 50	118 ± 2
	ACS3-CAPWC605		8 (8.4)	5000 ± 50	197 ± 2
	ACS3-CAPWC610		8 (8.4)	10000 ± 100	394 ± 4
	ACS3-CAPWC620		8 (8.4)	20000 ± 100	787 ± 4
Flexible	ACS3-CAPFC303	3106A-22-22S	14 (2.1)	3000 ± 50	118 ± 2
	ACS3-CAPFC305		14 (2.1)	5000 ± 50	197 ± 2
	ACS3-CAPFC310		14 (2.1)	10000 ± 100	394 ± 4
	ACS3-CAPFC320		14 (2.1)	20000 ± 100	787 ± 4
	ACS3-CAPFC403		12 (3.3)	3000 ± 50	118 ± 2
	ACS3-CAPFC405		12 (3.3)	5000 ± 50	197 ± 2
	ACS3-CAPFC410		12 (3.3)	10000 ± 100	394 ± 4
	ACS3-CAPFC420		12 (3.3)	20000 ± 100	787 ± 4
	ACS3-CAPFC503		10 (5.3)	3000 ± 50	118 ± 2
	ACS3-CAPFC505		10 (5.3)	5000 ± 50	197 ± 2
	ACS3-CAPFC510		10 (5.3)	10000 ± 100	394 ± 4
	ACS3-CAPFC520		10 (5.3)	20000 ± 100	787 ± 4
	ACS3-CAPFC603		8 (8.4)	3000 ± 50	118 ± 2
	ACS3-CAPFC605		8 (8.4)	5000 ± 50	197 ± 2
	ACS3-CAPFC610		8 (8.4)	10000 ± 100	394 ± 4
	ACS3-CAPFC620		8 (8.4)	20000 ± 100	787 ± 4

Note: brake cables are sold separately. Refer to Section B.2.5.

**Cable with right angle military connector for B3 non-brake motors (applicable to 220V and 400V models)**

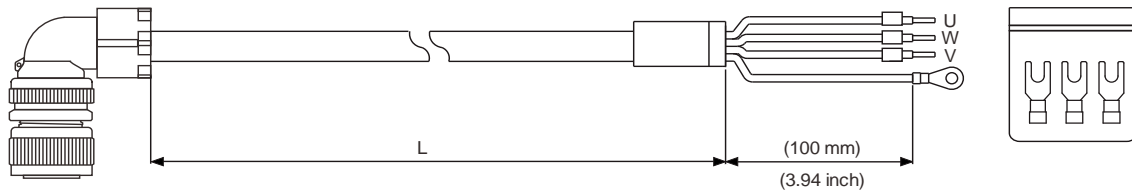

B

Cable type	Model number	Connector	Wire diameter	L	
			AWG (mm <sup>2</sup> )	mm	inch
Standard	ACS3-CRPWC303	3108A-22-22S	14 (2.1)	3000 ± 50	118 ± 2
	ACS3-CRPWC305		14 (2.1)	5000 ± 50	197 ± 2
	ACS3-CRPWC310		14 (2.1)	10000 ± 100	394 ± 4
	ACS3-CRPWC320		14 (2.1)	20000 ± 100	787 ± 4
	ACS3-CRPWC403		12 (3.3)	3000 ± 50	118 ± 2
	ACS3-CRPWC405		12 (3.3)	5000 ± 50	197 ± 2
	ACS3-CRPWC410		12 (3.3)	10000 ± 100	394 ± 4
	ACS3-CRPWC420		12 (3.3)	20000 ± 100	787 ± 4
	ACS3-CRPWC503		10 (5.3)	3000 ± 50	118 ± 2
	ACS3-CRPWC505		10 (5.3)	5000 ± 50	197 ± 2
	ACS3-CRPWC510		10 (5.3)	10000 ± 100	394 ± 4
	ACS3-CRPWC520		10 (5.3)	20000 ± 100	787 ± 4
	ACS3-CRPWC603		8 (8.4)	3000 ± 50	118 ± 2
	ACS3-CRPWC605		8 (8.4)	5000 ± 50	197 ± 2
	ACS3-CRPWC610		8 (8.4)	10000 ± 100	394 ± 4
	ACS3-CRPWC620		8 (8.4)	20000 ± 100	787 ± 4
Flexible	ACS3-CRPFC303	3108A-22-22S	14 (2.1)	3000 ± 50	118 ± 2
	ACS3-CRPFC305		14 (2.1)	5000 ± 50	197 ± 2
	ACS3-CRPFC310		14 (2.1)	10000 ± 100	394 ± 4
	ACS3-CRPFC320		14 (2.1)	20000 ± 100	787 ± 4
	ACS3-CRPFC403		12 (3.3)	3000 ± 50	118 ± 2
	ACS3-CRPFC405		12 (3.3)	5000 ± 50	197 ± 2
	ACS3-CRPFC410		12 (3.3)	10000 ± 100	394 ± 4
	ACS3-CRPFC420		12 (3.3)	20000 ± 100	787 ± 4
	ACS3-CRPFC503		10 (5.3)	3000 ± 50	118 ± 2
	ACS3-CRPFC505		10 (5.3)	5000 ± 50	197 ± 2
	ACS3-CRPFC510		10 (5.3)	10000 ± 100	394 ± 4
	ACS3-CRPFC520		10 (5.3)	20000 ± 100	787 ± 4
	ACS3-CRPFC603		8 (8.4)	3000 ± 50	118 ± 2
	ACS3-CRPFC605		8 (8.4)	5000 ± 50	197 ± 2
	ACS3-CRPFC610		8 (8.4)	10000 ± 100	394 ± 4
	ACS3-CRPFC620		8 (8.4)	20000 ± 100	787 ± 4

Note: brake cables are sold separately. Refer to Section B.2.5.

**B.2.4 F180 5.5 kW (or above) and F220 motors**

**Cable with straight military connector for B3 non-brake motors (applicable to 220V and 400V models)**

B

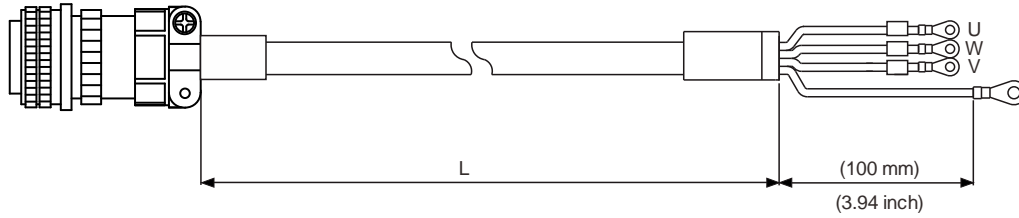

Cable type	Model number	Connector	Wire diameter	L	
			AWG (mm <sup>2</sup> )	mm	inch
Standard	ACS3-CAPWE603	3106A-32-17S	8 (8.4)	3000 ± 50	118 ± 2
	ACS3-CAPWE605		5000 ± 50	197 ± 2	
	ACS3-CAPWE610		10000 ± 100	394 ± 4	
	ACS3-CAPWE620		20000 ± 100	787 ± 4	
	ACS3-CAPWE703		6 (13.3)	3000 ± 50	118 ± 2
	ACS3-CAPWE705		5000 ± 50	197 ± 2	
	ACS3-CAPWE710		10000 ± 100	394 ± 4	
	ACS3-CAPWE720		20000 ± 100	787 ± 4	
	ACS3-CAPWE803		4 (21.2)	3000 ± 50	118 ± 2
	ACS3-CAPWE805		5000 ± 50	197 ± 2	
	ACS3-CAPWE810		10000 ± 100	394 ± 4	
	ACS3-CAPWE820		20000 ± 100	787 ± 4	
Flexible	ACS3-CAPFE603		8 (8.4)	3000 ± 50	118 ± 2
	ACS3-CAPFE605		8 (8.4)	5000 ± 50	197 ± 2
	ACS3-CAPFE610		8 (8.4)	10000 ± 100	394 ± 4
	ACS3-CAPFE620		8 (8.4)	20000 ± 100	787 ± 4
	ACS3-CAPFE703		6 (13.3)	3000 ± 50	118 ± 2
	ACS3-CAPFE705		6 (13.3)	5000 ± 50	197 ± 2
	ACS3-CAPFE710		6 (13.3)	10000 ± 100	394 ± 4
	ACS3-CAPFE720		6 (13.3)	20000 ± 100	787 ± 4
	ACS3-CAPFE803		4 (21.2)	3000 ± 50	118 ± 2
	ACS3-CAPFE805		4 (21.2)	5000 ± 50	197 ± 2
	ACS3-CAPFE810		4 (21.2)	10000 ± 100	394 ± 4
	ACS3-CAPFE820		4 (21.2)	20000 ± 100	787 ± 4

**Cable with right angle military connector for B3 non-brake motors (applicable to 220V and 400V models)**

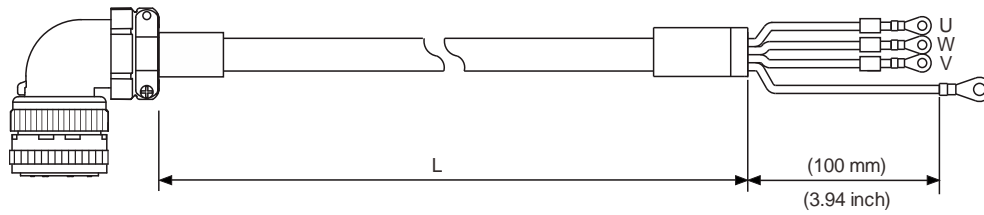

B

Cable type	Model number	Connector	Wire diameter	L		
			AWG (mm <sup>2</sup> )	mm	inch	
Standard	ACS3-CRPWE603	3108A-32-17S	8 (8.4)	3000 ± 50	118 ± 2	
	ACS3-CRPWE605		8 (8.4)	5000 ± 50	197 ± 2	
	ACS3-CRPWE610		8 (8.4)	10000 ± 100	394 ± 4	
	ACS3-CRPWE620		8 (8.4)	20000 ± 100	787 ± 4	
	ACS3-CRPWE703		6 (13.3)	3000 ± 50	118 ± 2	
	ACS3-CRPWE705		6 (13.3)	5000 ± 50	197 ± 2	
	ACS3-CRPWE710		6 (13.3)	10000 ± 100	394 ± 4	
	ACS3-CRPWE720		6 (13.3)	20000 ± 100	787 ± 4	
	ACS3-CRPWE803		4 (21.2)	3000 ± 50	118 ± 2	
	ACS3-CRPWE805		4 (21.2)	5000 ± 50	197 ± 2	
	ACS3-CRPWE810		4 (21.2)	10000 ± 100	394 ± 4	
	ACS3-CRPWE820		4 (21.2)	20000 ± 100	787 ± 4	
Flexible	ACS3-CRPFE603		3108A-32-17S	8 (8.4)	3000 ± 50	118 ± 2
	ACS3-CRPFE605			8 (8.4)	5000 ± 50	197 ± 2
	ACS3-CRPFE610			8 (8.4)	10000 ± 100	394 ± 4
	ACS3-CRPFE620			8 (8.4)	20000 ± 100	787 ± 4
	ACS3-CRPFE703			6 (13.3)	3000 ± 50	118 ± 2
	ACS3-CRPFE705			6 (13.3)	5000 ± 50	197 ± 2
	ACS3-CRPFE710			6 (13.3)	10000 ± 100	394 ± 4
	ACS3-CRPFE720			6 (13.3)	20000 ± 100	787 ± 4
	ACS3-CRPFE803			4 (21.2)	3000 ± 50	118 ± 2
	ACS3-CRPFE805			4 (21.2)	5000 ± 50	197 ± 2
	ACS3-CRPFE810	4 (21.2)		10000 ± 100	394 ± 4	
	ACS3-CRPFE820	4 (21.2)		20000 ± 100	787 ± 4	

Note: brake cables are sold separately. Refer to Section B.2.5.

### B.2.5 Brake cable for F100 - F220 motors

Cable with straight military connector (bayonet) for B3 brake motors (applicable to 220V and 400V models)

B

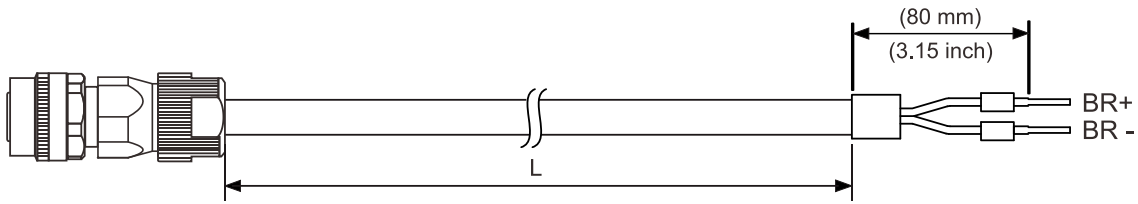

Cable type	Model number	Connector	Wire diameter	L	
			AWG (mm <sup>2</sup> )	mm	inch
Standard	ACS3-CABRA103	CMV1-SP2S	20 (0.52)	3000 ± 100	118 ± 4
	ACS3-CABRA105		20 (0.52)	5000 ± 100	197 ± 4
	ACS3-CABRA110		20 (0.52)	10000 ± 100	394 ± 4
	ACS3-CABRA120		20 (0.52)	20000 ± 100	787 ± 4
Flexible	ACS3-CABFA103		20 (0.52)	3000 ± 100	118 ± 4
	ACS3-CABFA105		20 (0.52)	5000 ± 100	197 ± 4
	ACS3-CABFA110		20 (0.52)	10000 ± 100	394 ± 4
	ACS3-CABFA120		20 (0.52)	20000 ± 100	787 ± 4

Note: use bayonet connectors for motors with bayonet or threaded bayonet connectors.

Cable with straight military connector (threaded) for B3 brake motors (applicable to 220V and 400V models)

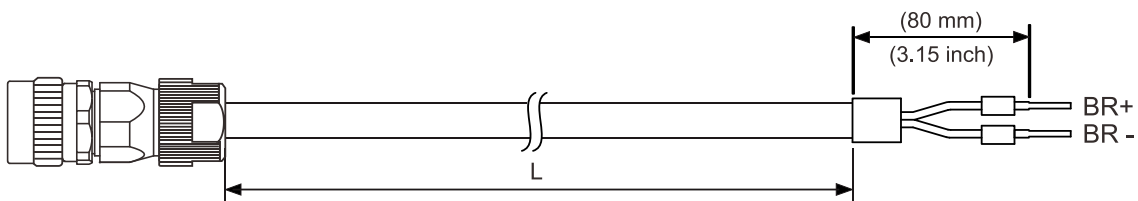

Cable type	Model number	Connector	Wire diameter	L	
			AWG (mm <sup>2</sup> )	mm	inch
Standard	ACS3-CABRM103	Threaded M17.5	20 (0.52)	3000 ± 100	118 ± 4
	ACS3-CABRM105		20 (0.52)	5000 ± 100	197 ± 4
	ACS3-CABRM110		20 (0.52)	10000 ± 100	394 ± 4
	ACS3-CABRM120		20 (0.52)	20000 ± 100	787 ± 4
Flexible	ACS3-CABFM103		20 (0.52)	3000 ± 100	118 ± 4
	ACS3-CABFM105		20 (0.52)	5000 ± 100	197 ± 4
	ACS3-CABFM110		20 (0.52)	10000 ± 100	394 ± 4
	ACS3-CABFM120		20 (0.52)	20000 ± 100	787 ± 4

Note: use threaded connectors for motors with threaded bayonet connectors.

**Cable with right angle military connector (bayonet) for B3 brake motors (applicable to 220V and 400V models)**

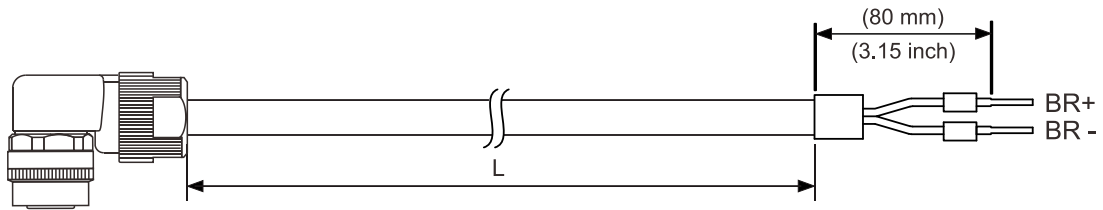

B

Cable type	Model number	Connector	Wire diameter	L	
			AWG (mm <sup>2</sup> )	mm	inch
Standard	ACS3-CRBRA103	CMV1-AP2S	20 (0.52)	3000 ± 100	118 ± 4
	ACS3-CRBRA105		5000 ± 100	197 ± 4	
	ACS3-CRBRA110		10000 ± 100	394 ± 4	
	ACS3-CRBRA120		20000 ± 100	787 ± 4	
Flexible	ACS3-CRBFA103		20 (0.52)	3000 ± 100	118 ± 4
	ACS3-CRBFA105		20 (0.52)	5000 ± 100	197 ± 4
	ACS3-CRBFA110		20 (0.52)	10000 ± 100	394 ± 4
	ACS3-CRBFA120		20 (0.52)	20000 ± 100	787 ± 4

Note: use bayonet connectors for motors with bayonet or threaded bayonet connectors.

**Cable with right angle military connector (threaded) for B3 brake motors (applicable to 220V and 400V models)**

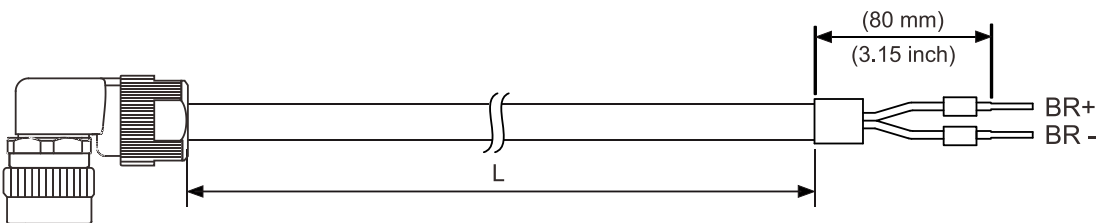

Cable type	Model number	Connector	Wire diameter	L	
			AWG (mm <sup>2</sup> )	mm	inch
Standard	ACS3-CRBRM103	Threaded M17.5	20 (0.52)	3000 ± 100	118 ± 4
	ACS3-CRBRM105		5000 ± 100	197 ± 4	
	ACS3-CRBRM110		10000 ± 100	394 ± 4	
	ACS3-CRBRM120		20000 ± 100	787 ± 4	
Flexible	ACS3-CRBFM103		20 (0.52)	3000 ± 100	118 ± 4
	ACS3-CRBFM105		20 (0.52)	5000 ± 100	197 ± 4
	ACS3-CRBFM110		20 (0.52)	10000 ± 100	394 ± 4
	ACS3-CRBFM120		20 (0.52)	20000 ± 100	787 ± 4

Note: use threaded connectors for motors with threaded bayonet connectors.

B

### B.3 Encoder connector

#### Servo drive end

Delta model number: ACS3-CNENC200

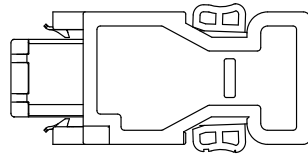

#### B.3.1 F40 - F80 motors

The following are connectors for the motor end, which need to be used with the connector (ACS3-CNENC200) for the servo drive end.

#### Standard connector

Delta model number: ACS3-CAEN0000

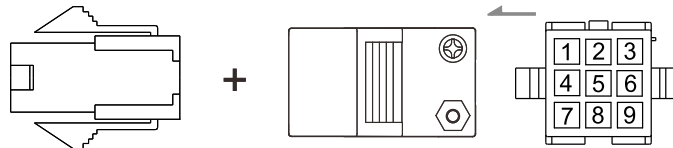

#### CHOGORI connector

Delta model number: ACS3-CNEN2A00

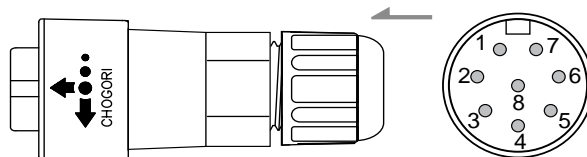

Note: refer to Section 3.1.7 Waterproof connector wiring instructions for more information.

#### Bulkhead connector

Delta model number: ACS3-AFEASA00

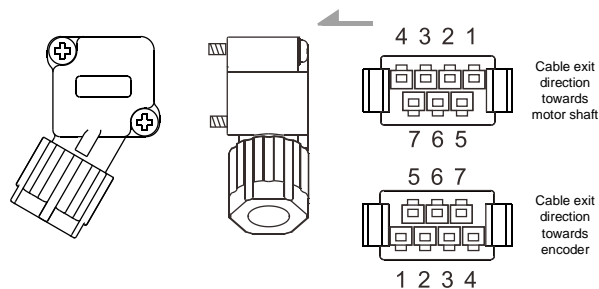

Note:

1. Refer to Section 3.1.7 Waterproof connector wiring instructions for more information.
2. Only one wiring terminal is attached. The cable exit direction is illustrated in the preceding figure.

### B.3.2 F100 - F220 motors

The following are connectors for the motor end, which need to be used with the connector (ACS3-CNENC200) for the servo drive end.

- Use bayonet connectors for motors with bayonet or threaded bayonet connectors.
- Use threaded connectors for motors with threaded bayonet connectors.

#### Straight military connector (bayonet) for B3 motors

Delta model number: ACS3-CAENA000

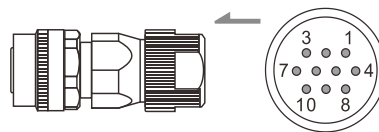

Note: refer to Section 3.1.7 IP67 connector wiring instructions for more information.

#### Straight military connector (threaded, M17.5) for B3 motors

Delta model number: ACS3-CAENM000

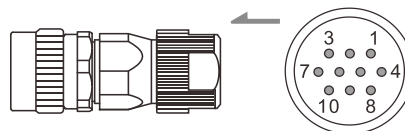

Note: refer to Section 3.1.7 IP67 connector wiring instructions for more information.

#### Right angle military connector (bayonet) for B3 motors

Delta model number: ACS3-CRENA000

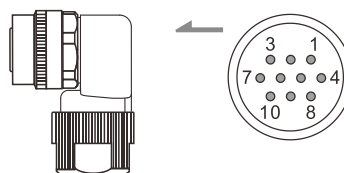

Note: refer to Section 3.1.7 IP67 connector wiring instructions for more information.

#### Right angle military connector (threaded, M17.5) for B3 motors

Delta model number: ACS3-CRENM000

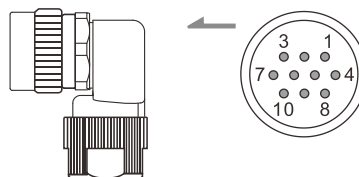

Note: refer to Section 3.1.7 IP67 connector wiring instructions for more information.



## B.4 Encoder cable (incremental type)

### B.4.1 F40 - F80 motors

B

Cable with standard connector for A3 / B3 motors

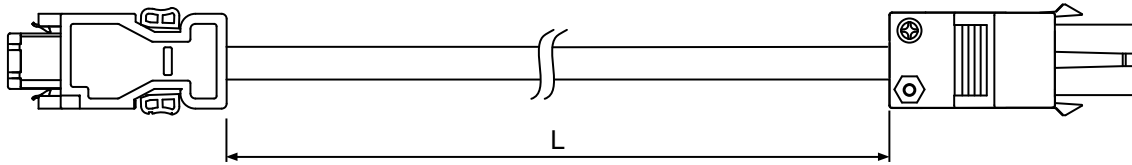

Cable type	Model number	L	
		mm	inch
Standard	ACS3-CAEN0103	3000 ± 50	118 ± 2
	ACS3-CAEN0105	5000 ± 50	197 ± 2
	ACS3-CAEN0110	10000 ± 100	394 ± 4
	ACS3-CAEN0120	20000 ± 100	787 ± 4
Flexible	ACS3-CAEF0103	3000 ± 50	118 ± 2
	ACS3-CAEF0105	5000 ± 50	197 ± 2
	ACS3-CAEF0110	10000 ± 100	394 ± 4
	ACS3-CAEF0120	20000 ± 100	787 ± 4

Cable with CHOGORI connector for A3 / B3 motors (applicable to 220V models)

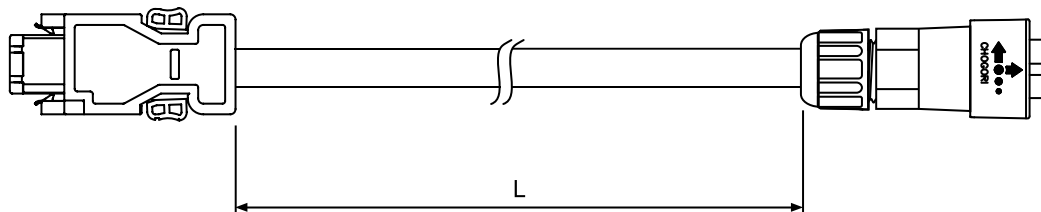

Cable type	Model number	L	
		mm	inch
Standard	ACS3-CAEN1103	3000 ± 50	118 ± 2
	ACS3-CAEN1105	5000 ± 50	197 ± 2
	ACS3-CAEN1110	10000 ± 100	394 ± 4
	ACS3-CAEN1120	20000 ± 100	787 ± 4
Flexible	ACS3-CAEF1103	3000 ± 50	118 ± 2
	ACS3-CAEF1105	5000 ± 50	197 ± 2
	ACS3-CAEF1110	10000 ± 100	394 ± 4
	ACS3-CAEF1120	20000 ± 100	787 ± 4

**Cable with bulkhead connector (cable exit direction towards motor shaft) for B3 motors**

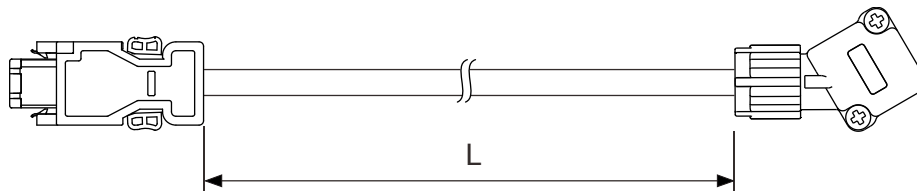

B

Cable type	Model number	L	
		mm	inch
Standard	ACS3-AFEASI03	3000 ± 50	118 ± 2
	ACS3-AFEASI05	5000 ± 50	197 ± 2
	ACS3-AFEASI10	10000 ± 100	394 ± 4
	ACS3-AFEASI20	20000 ± 100	787 ± 4
Flexible	ACS3-AFERSI03	3000 ± 50	118 ± 2
	ACS3-AFERSI05	5000 ± 50	197 ± 2
	ACS3-AFERSI10	10000 ± 100	394 ± 4
	ACS3-AFERSI20	20000 ± 100	787 ± 4

**Cable with bulkhead connector (cable exit direction towards encoder) for B3 motors**

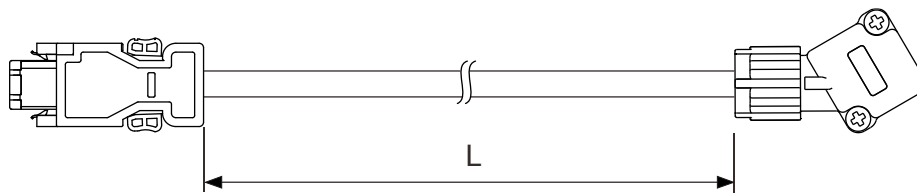

Cable type	Model number	L	
		mm	inch
Standard	ACS3-ABEASI03	3000 ± 50	118 ± 2
	ACS3-ABEASI05	5000 ± 50	197 ± 2
	ACS3-ABEASI10	10000 ± 100	394 ± 4
	ACS3-ABEASI20	20000 ± 100	787 ± 4
Flexible	ACS3-ABERSI03	3000 ± 50	118 ± 2
	ACS3-ABERSI05	5000 ± 50	197 ± 2
	ACS3-ABERSI10	10000 ± 100	394 ± 4
	ACS3-ABERSI20	20000 ± 100	787 ± 4

### B.4.2 F100 - F220 motors

#### Cable with straight military connector (bayonet) for B3 motors

B

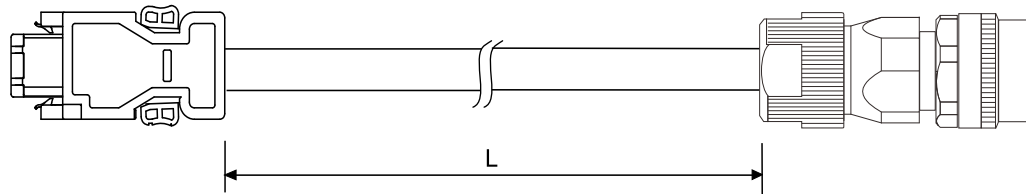

Cable type	Model number	Connector	L	
			mm	inch
Standard	ACS3-CAENA103	CMV1-SP10S	3000 ± 50	118 ± 2
	ACS3-CAENA105		5000 ± 50	197 ± 2
	ACS3-CAENA110		10000 ± 100	394 ± 4
	ACS3-CAENA120		20000 ± 100	787 ± 4
Flexible	ACS3-CAEFA103		3000 ± 50	118 ± 2
	ACS3-CAEFA105		5000 ± 50	197 ± 2
	ACS3-CAEFA110		10000 ± 100	394 ± 4
	ACS3-CAEFA120		20000 ± 100	787 ± 4

Note: use bayonet connectors for motors with bayonet or threaded bayonet connectors.

#### Cable with straight military connector (threaded) for B3 motors

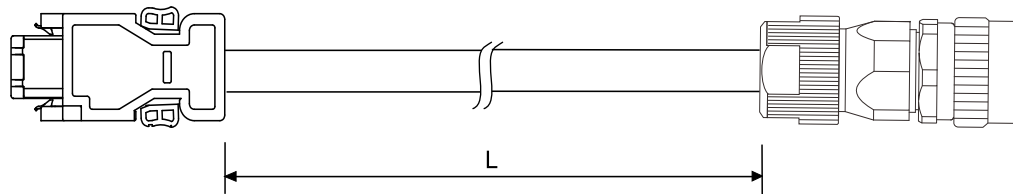

Cable type	Model number	Connector	L	
			mm	inch
Standard	ACS3-CAENM103	Threaded M17.5	3000 ± 50	118 ± 2
	ACS3-CAENM105		5000 ± 50	197 ± 2
	ACS3-CAENM110		10000 ± 100	394 ± 4
	ACS3-CAENM120		20000 ± 100	787 ± 4
Flexible	ACS3-CAEFM103		3000 ± 50	118 ± 2
	ACS3-CAEFM105		5000 ± 50	197 ± 2
	ACS3-CAEFM110		10000 ± 100	394 ± 4
	ACS3-CAEFM120		20000 ± 100	787 ± 4

Note: use threaded connectors for motors with threaded bayonet connectors.

**Cable with right angle military connector (bayonet) for B3 motors**

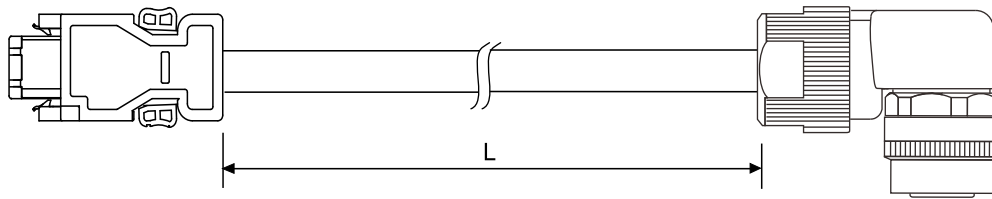

B

Cable type	Model number	Connector	L	
			mm	inch
Standard	ACS3-CRENA103	CMV1-AP10S	3000 ± 50	118 ± 2
	ACS3-CRENA105		5000 ± 50	197 ± 2
	ACS3-CRENA110		10000 ± 100	394 ± 4
	ACS3-CRENA120		20000 ± 100	787 ± 4
Flexible	ACS3-CREFA103		3000 ± 50	118 ± 2
	ACS3-CREFA105		5000 ± 50	197 ± 2
	ACS3-CREFA110		10000 ± 100	394 ± 4
	ACS3-CREFA120		20000 ± 100	787 ± 4

Note: use bayonet connectors for motors with bayonet or threaded bayonet connectors.

**Cable with right angle military connector (threaded) for B3 motors**

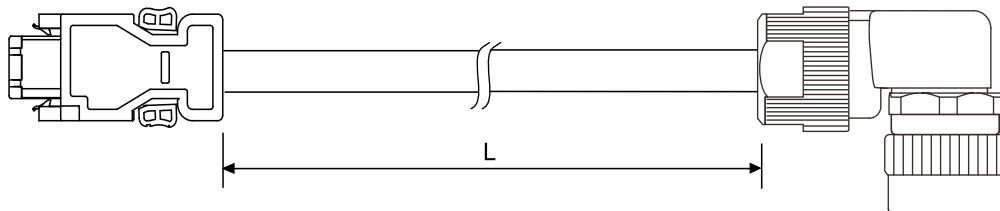

Cable type	Model number	Connector	L	
			mm	inch
Standard	ACS3-CRENM103	Threaded M17.5	3000 ± 50	118 ± 2
	ACS3-CRENM105		5000 ± 50	197 ± 2
	ACS3-CRENM110		10000 ± 100	394 ± 4
	ACS3-CRENM120		20000 ± 100	787 ± 4
Flexible	ACS3-CREFM103		3000 ± 50	118 ± 2
	ACS3-CREFM105		5000 ± 50	197 ± 2
	ACS3-CREFM110		10000 ± 100	394 ± 4
	ACS3-CREFM120		20000 ± 100	787 ± 4

Note: use threaded connectors for motors with threaded bayonet connectors.

## B.5 Encoder cable (absolute type)

### B.5.1 F40 - F80 motors

Cable with standard connector for A3 / B3 motors

B

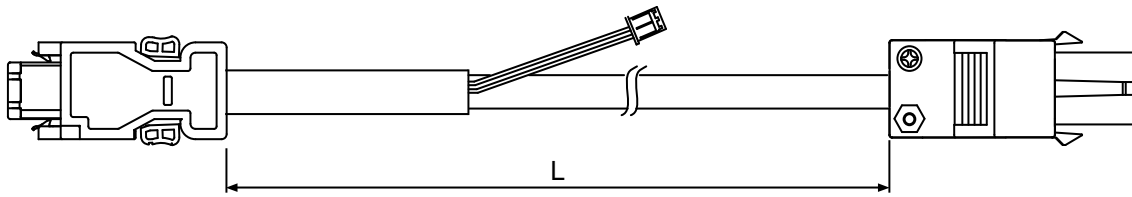

Cable type	Model number	L	
		mm	inch
Standard	ACS3-CAEA0103	3000 ± 50	118 ± 2
	ACS3-CAEA0105	5000 ± 50	197 ± 2
	ACS3-CAEA0110	10000 ± 100	394 ± 4
	ACS3-CAEA0120	20000 ± 100	787 ± 4
Flexible	ACS3-CAEB0103	3000 ± 50	118 ± 2
	ACS3-CAEB0105	5000 ± 50	197 ± 2
	ACS3-CAEB0110	10000 ± 100	394 ± 4
	ACS3-CAEB0120	20000 ± 100	787 ± 4

Cable with CHOGORI connector for A3 / B3 motors (applicable to 220V models)

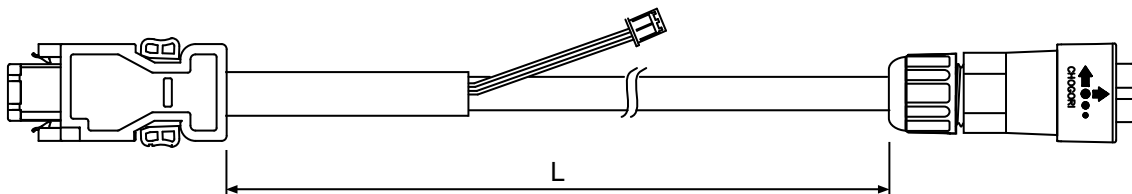

Cable type	Model number	L	
		mm	inch
Standard	ACS3-CAEA1103	3000 ± 50	118 ± 2
	ACS3-CAEA1105	5000 ± 50	197 ± 2
	ACS3-CAEA1110	10000 ± 100	394 ± 4
	ACS3-CAEA1120	20000 ± 100	787 ± 4
Flexible	ACS3-CAEB1103	3000 ± 50	118 ± 2
	ACS3-CAEB1105	5000 ± 50	197 ± 2
	ACS3-CAEB1110	10000 ± 100	394 ± 4
	ACS3-CAEB1120	20000 ± 100	787 ± 4

**Cable with bulkhead connector (cable exit direction towards motor shaft) for B3 motors**

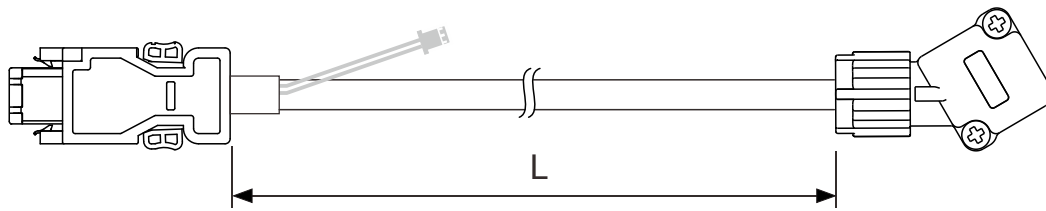

B

Cable type	Model number	L	
		mm	inch
Standard	ACS3-AFEASA03	3000 ± 50	118 ± 2
	ACS3-AFEASA05	5000 ± 50	197 ± 2
	ACS3-AFEASA10	10000 ± 100	394 ± 4
	ACS3-AFEASA20	20000 ± 100	787 ± 4
Flexible	ACS3-AFERSA03	3000 ± 50	118 ± 2
	ACS3-AFERSA05	5000 ± 50	197 ± 2
	ACS3-AFERSA10	10000 ± 100	394 ± 4
	ACS3-AFERSA20	20000 ± 100	787 ± 4

**Cable with bulkhead connector (cable exit direction towards encoder) for B3 motors**

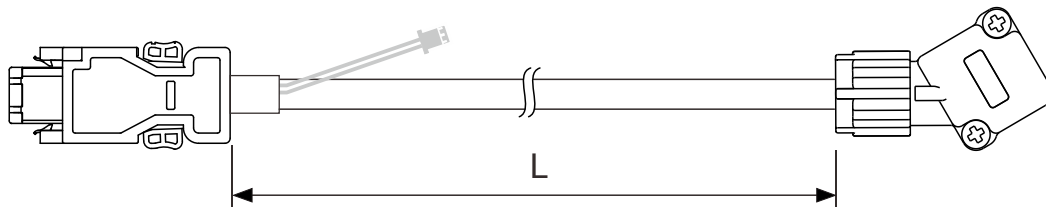

Cable type	Model number	L	
		mm	inch
Standard	ACS3-ABEASA03	3000 ± 50	118 ± 2
	ACS3-ABEASA05	5000 ± 50	197 ± 2
	ACS3-ABEASA10	10000 ± 100	394 ± 4
	ACS3-ABEASA20	20000 ± 100	787 ± 4
Flexible	ACS3-ABERSA03	3000 ± 50	118 ± 2
	ACS3-ABERSA05	5000 ± 50	197 ± 2
	ACS3-ABERSA10	10000 ± 100	394 ± 4
	ACS3-ABERSA20	20000 ± 100	787 ± 4

### B.5.2 F100 - F220 motors

#### Cable with straight military connector (bayonet) for B3 motors

B

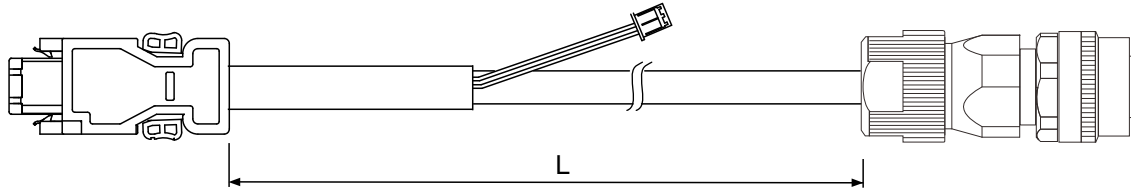

Cable type	Model number	Connector	L	
			mm	inch
Standard	ACS3-CAEAA103	CMV1-SP10S	3000 ± 50	118 ± 2
	ACS3-CAEAA105		5000 ± 50	197 ± 2
	ACS3-CAEAA110		10000 ± 100	394 ± 4
	ACS3-CAEAA120		20000 ± 100	787 ± 4
Flexible	ACS3-CAEBA103		3000 ± 50	118 ± 2
	ACS3-CAEBA105		5000 ± 50	197 ± 2
	ACS3-CAEBA110		10000 ± 100	394 ± 4
	ACS3-CAEBA120		20000 ± 100	787 ± 4

Note: use bayonet connectors for motors with bayonet or threaded bayonet connectors.

#### Cable with straight military connector (threaded) for B3 motors

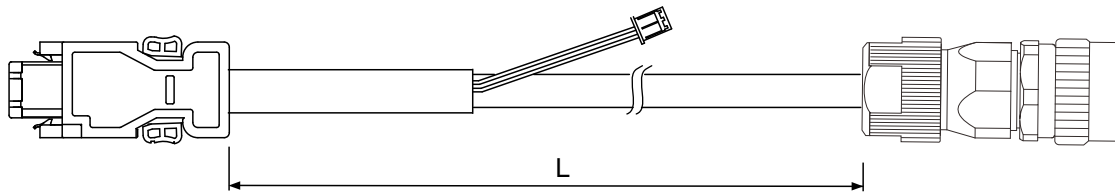

Cable type	Model number	Connector	L	
			mm	inch
Standard	ACS3-CAEAM103	Threaded M17.5	3000 ± 50	118 ± 2
	ACS3-CAEAM105		5000 ± 50	197 ± 2
	ACS3-CAEAM110		10000 ± 100	394 ± 4
	ACS3-CAEAM120		20000 ± 100	787 ± 4
Flexible	ACS3-CAEBM103		3000 ± 50	118 ± 2
	ACS3-CAEBM105		5000 ± 50	197 ± 2
	ACS3-CAEBM110		10000 ± 100	394 ± 4
	ACS3-CAEBM120		20000 ± 100	787 ± 4

Note: use threaded connectors for motors with threaded bayonet connectors.

**Cable with right angle military connector (bayonet) for B3 motors**

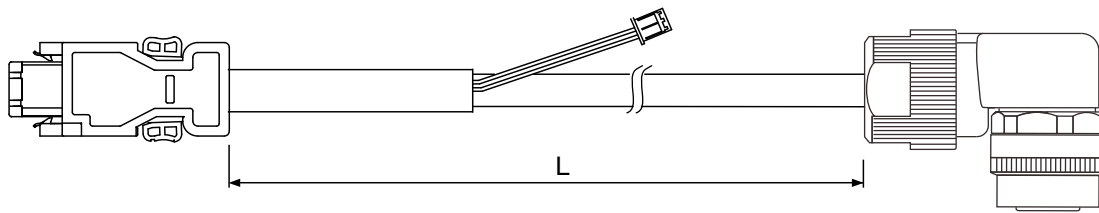

B

Cable type	Model number	Connector	L	
			mm	inch
Standard	ACS3-CREAA103	CMV1-AP10S	3000 ± 50	118 ± 2
	ACS3-CREAA105		5000 ± 50	197 ± 2
	ACS3-CREAA110		10000 ± 100	394 ± 4
	ACS3-CREAA120		20000 ± 100	787 ± 4
Flexible	ACS3-CREBA103		3000 ± 50	118 ± 2
	ACS3-CREBA105		5000 ± 50	197 ± 2
	ACS3-CREBA110		10000 ± 100	394 ± 4
	ACS3-CREBA120		20000 ± 100	787 ± 4

Note: use bayonet connectors for motors with bayonet or threaded bayonet connectors.

**Cable with right angle military connector (threaded) for B3 motors**

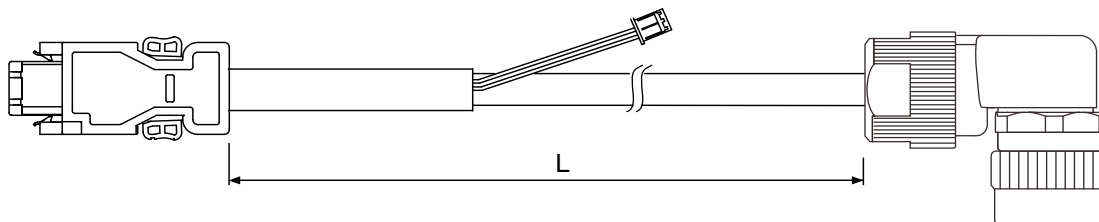

Cable type	Model number	Connector	L	
			mm	inch
Standard	ACS3-CREAM103	Threaded M17.5	3000 ± 50	118 ± 2
	ACS3-CREAM105		5000 ± 50	197 ± 2
	ACS3-CREAM110		10000 ± 100	394 ± 4
	ACS3-CREAM120		20000 ± 100	787 ± 4
Flexible	ACS3-CREBM103		3000 ± 50	118 ± 2
	ACS3-CREBM105		5000 ± 50	197 ± 2
	ACS3-CREBM110		10000 ± 100	394 ± 4
	ACS3-CREBM120		20000 ± 100	787 ± 4

Note: use threaded connectors for motors with threaded bayonet connectors.



## B.6 Battery box cable

### Battery box cable for customized wiring

Delta part number: 3864850600

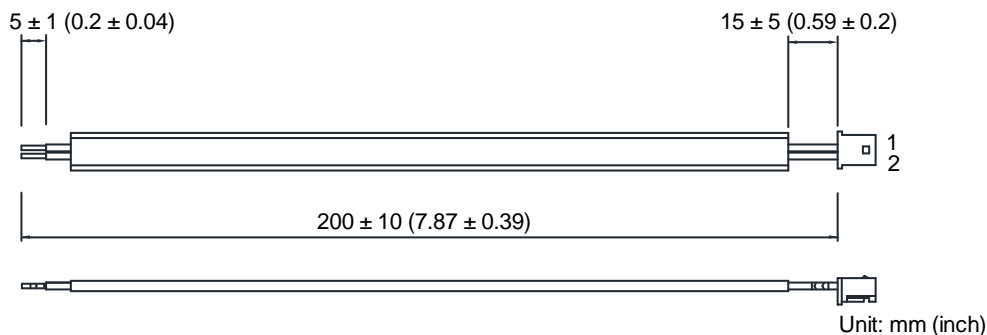

### Battery box cable that connects to the encoder cable (male to male)

Delta part number: 3864811901

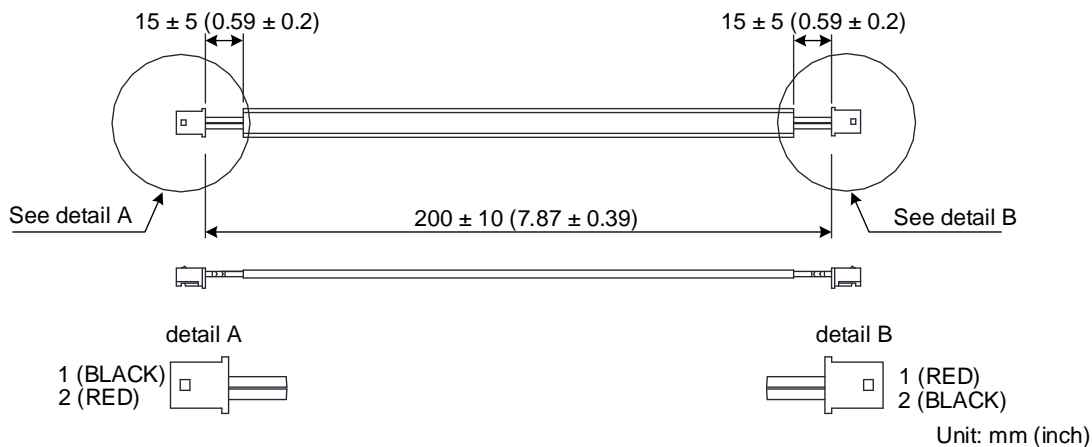

### Battery box cable that connects to the encoder cable (male to female)

Delta part number: 3864573700

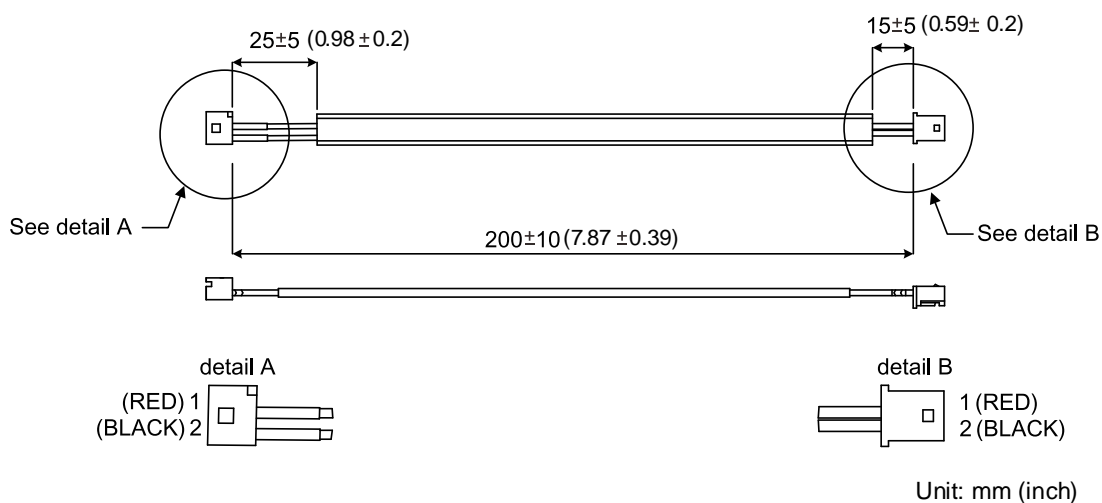

B

## B.7 Battery box

### Single battery box

Delta model number: ASD-MDBT0100

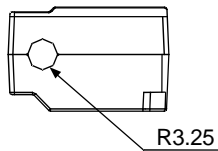
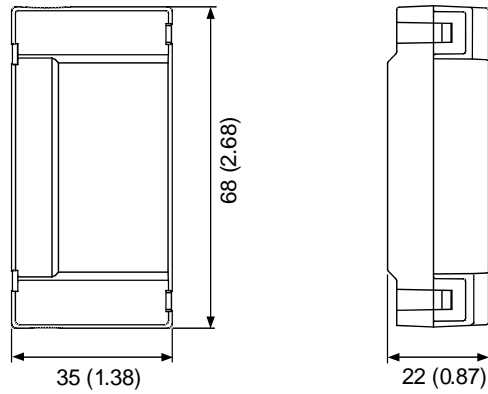

Unit: mm (inch)  
Weight: 44 g

### Dual battery box

Delta model number: ASD-MDBT0200

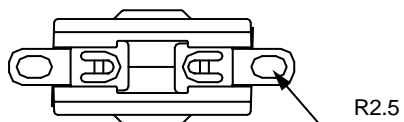
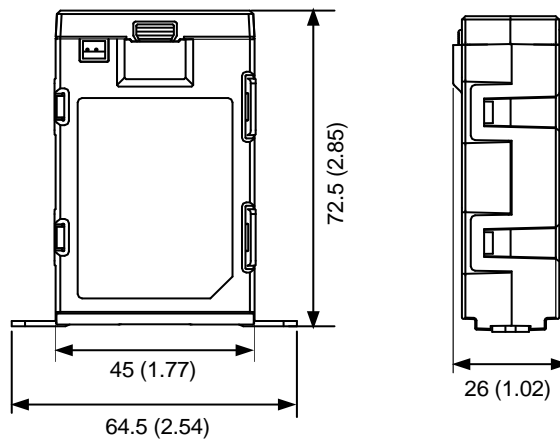

Unit: mm (inch)  
Weight: 79.23 g

B

## B.8 CN1 connector

Delta model number: ACS3-CNADC150 (for A3-L and A3-M servo drives)

B

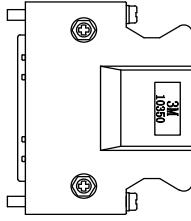

Delta model number: ASD-CNSC0026 (for A3-F and A3-E servo drives)

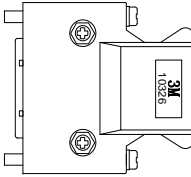

### B.9 CN1 quick connector

Delta model number: ACS3-IFSC5020 (for A3-L and A3-M servo drives)

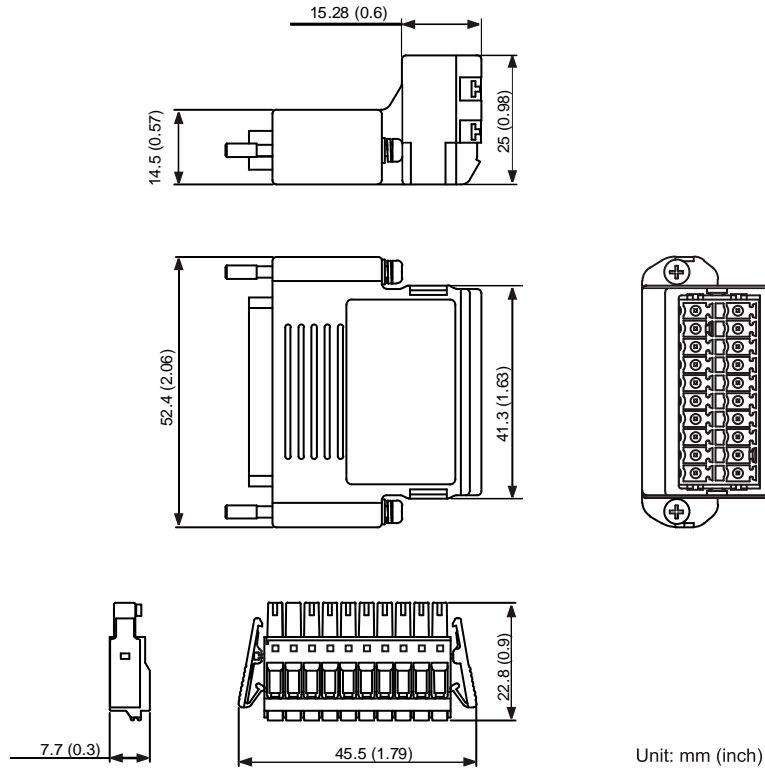

Delta model number: ACS3-IFSC2616 (for A3-F and A3-E servo drives)

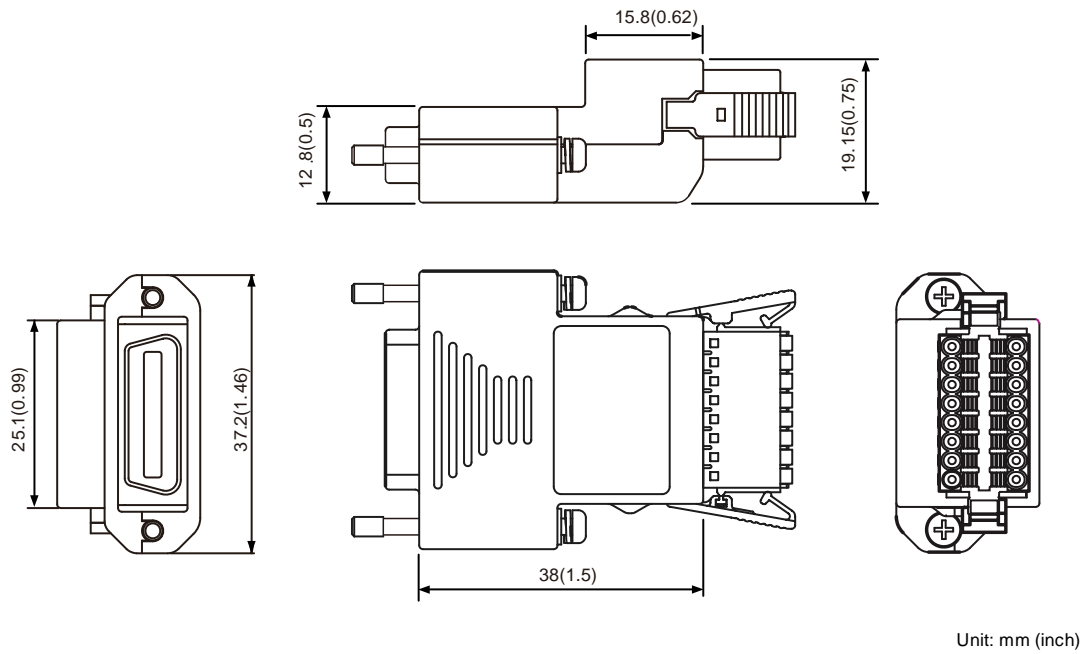

B

### B.10 CN1 terminal block module

Delta model number: ACS3-MDTB5000 (for A3-L and A3-M servo drives)

B

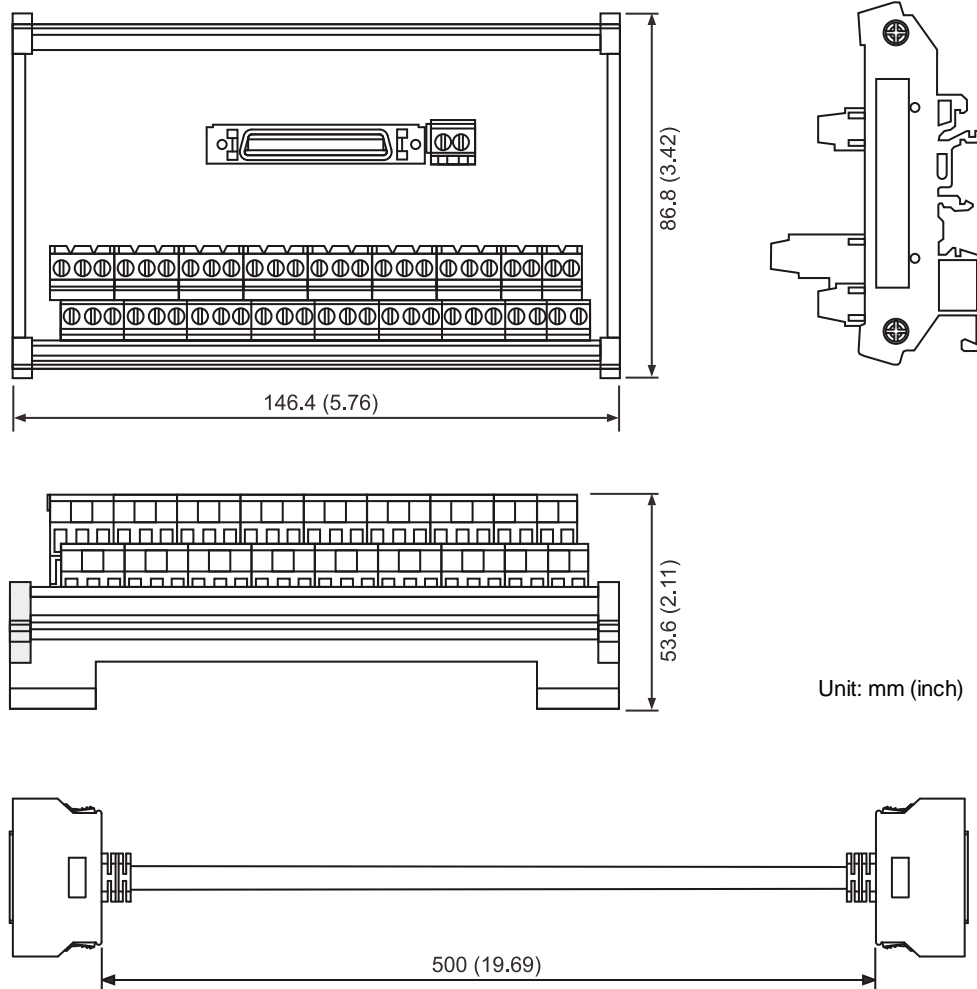

Delta model number: ACS3-MDTB2600 (for A3-F and A3-E servo drives)

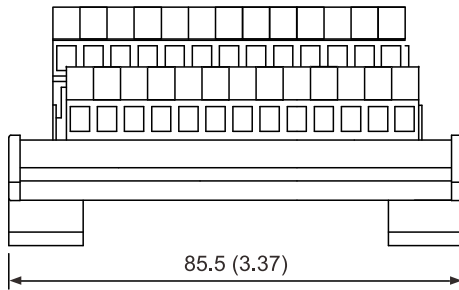
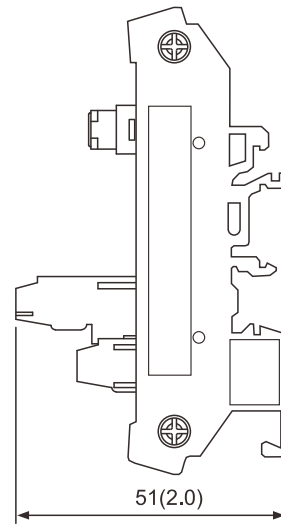
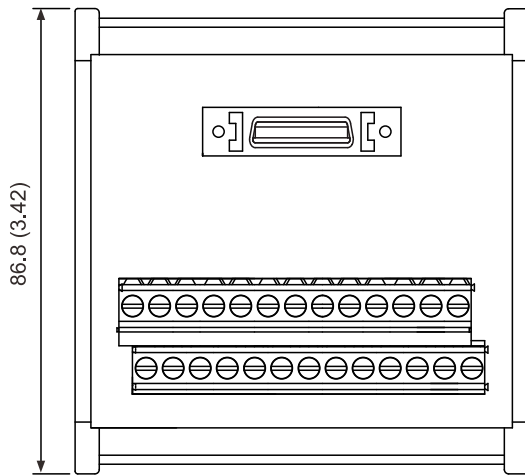

Unit: mm (inch)

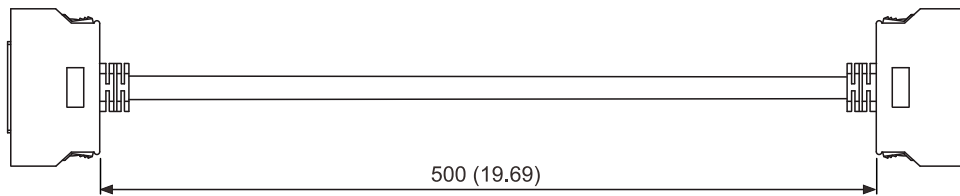

B

### B.11 CANopen communication cable

B

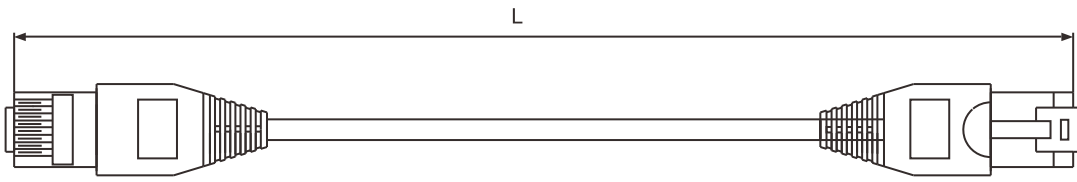

Model number	L	
	mm	inch
UC-CMC030-01A	300 ± 10	11 ± 0.4
UC-CMC050-01A	500 ± 10	19 ± 0.4

Note: for cables of other lengths, refer to the Delta PLC / HMI Cable Selection Guide.

### B.12 CANopen distribution box

Delta model number: TAP-CN03

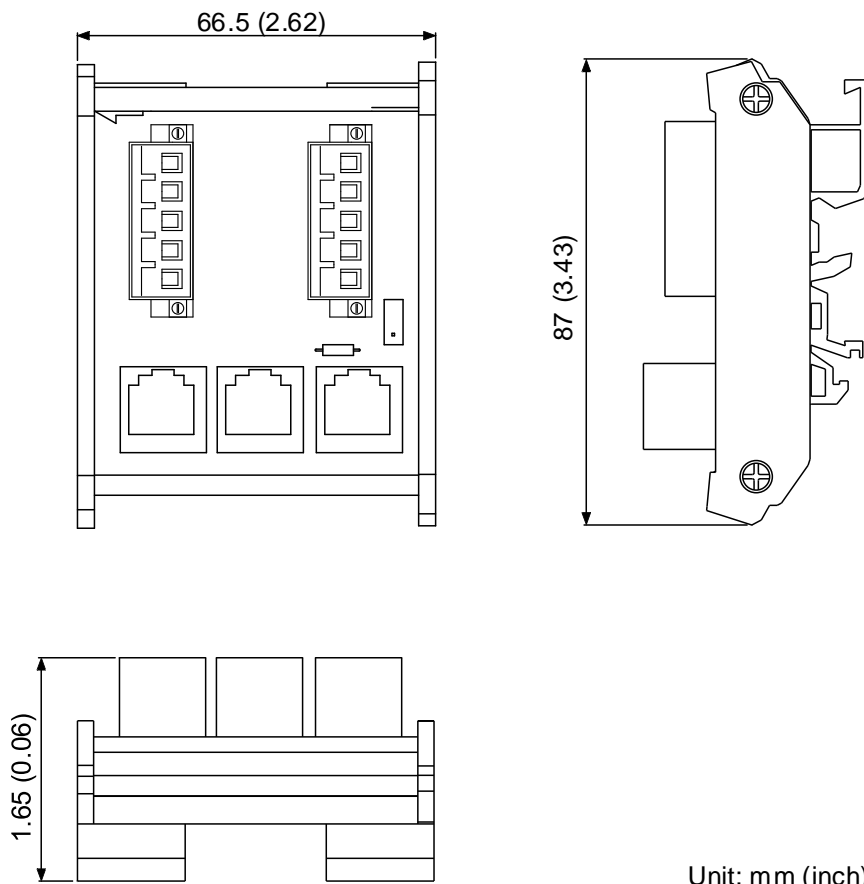

Unit: mm (inch)

### B.13 Ferrite ring

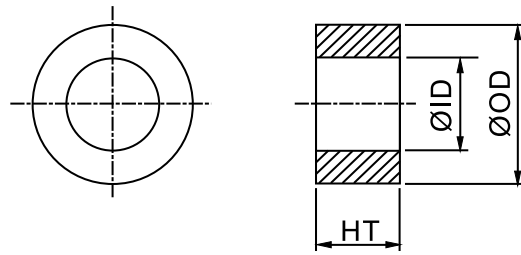

Unit: mm (inch)

Model number	Outer diameter ( $\Phi OD$ )	Inner diameter ( $\Phi ID$ )	Height (HT)
ASD-ACFC7K00	$68.0 \pm 0.6$ ( $2.68 \pm 0.02$ )	$44.0 \pm 0.6$ ( $1.73 \pm 0.02$ )	$13.5 \pm 0.5$ ( $0.53 \pm 0.02$ )

B

### B.14 A3 / A2 conversion cable

#### A3 / A2 CN1 conversion cable

Delta model number: ACS3-CAADC1

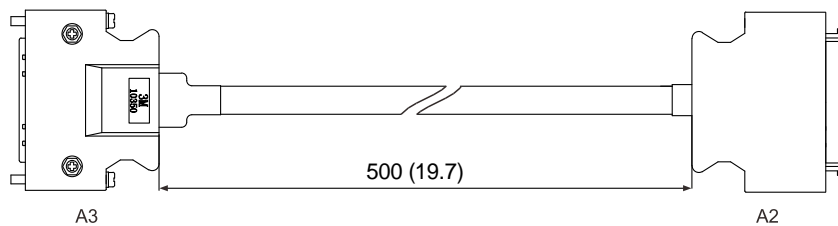

Unit: mm (inch)

#### A3 / A2 CN2 conversion cable

Delta model number: ACS3-CAADC2

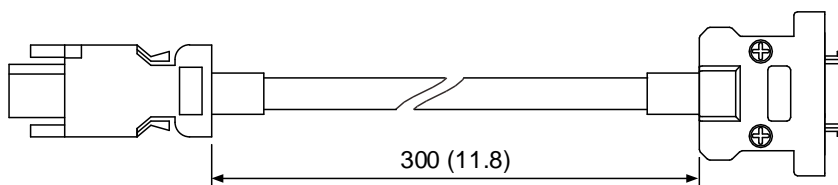

Unit: mm (inch)

#### A3 / A2 CN5 conversion cable

Delta model number: ACS3-CAADC5

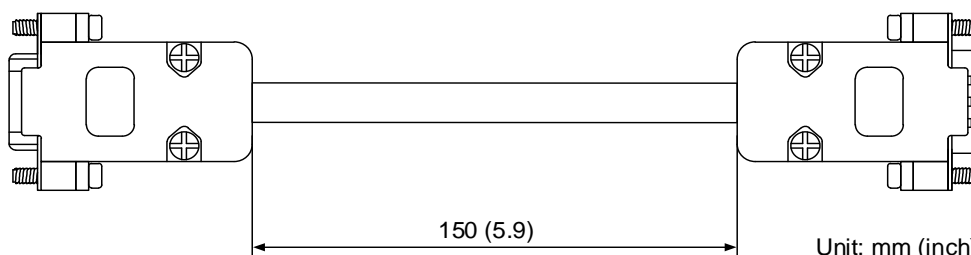

Unit: mm (inch)



### B.15 CN3 RS-485 splitter

Delta model number: ACS3-CNADC3RC

B

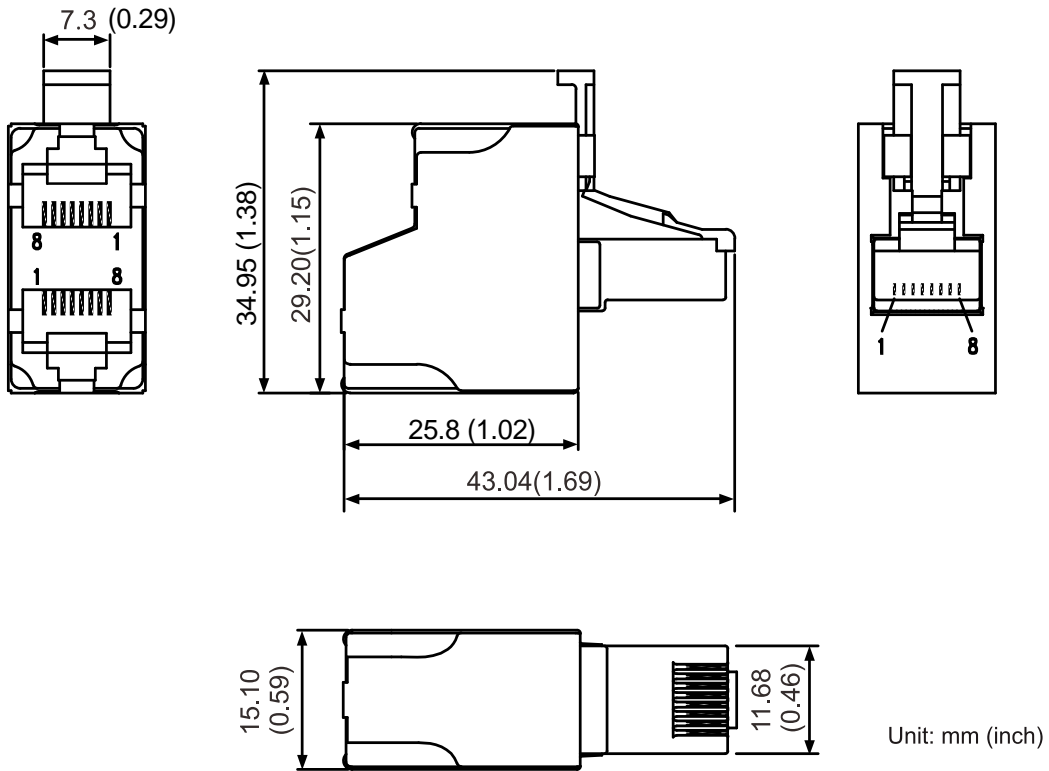

### B.16 CN3 RS-485 / CANopen terminal resistor

Delta model number: ACS3-CNADC3TR

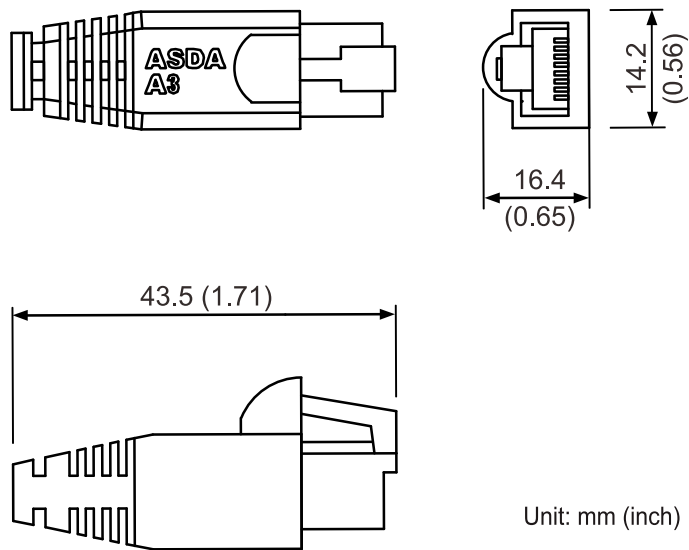

## B.17 CN4 Mini USB communication module

USB cable and isolator included

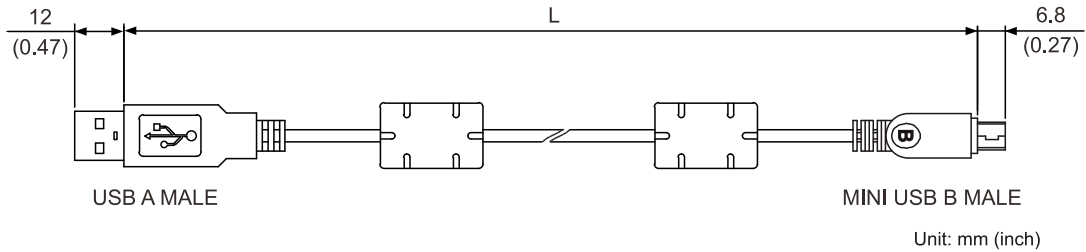
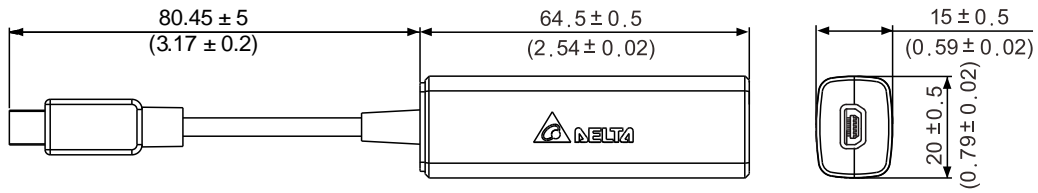

Model number	L	
	mm	inch
UC-PRG015-01B	1500 ± 100	59 ± 4
UC-PRG030-01B	3000 ± 100	118 ± 4

### USB isolator

Delta model number: UC-ADP01-A

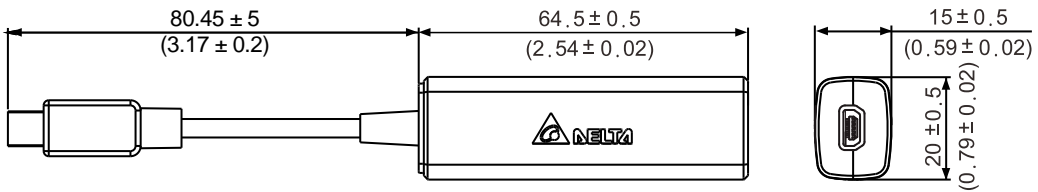

Unit: mm (inch)

### USB cable

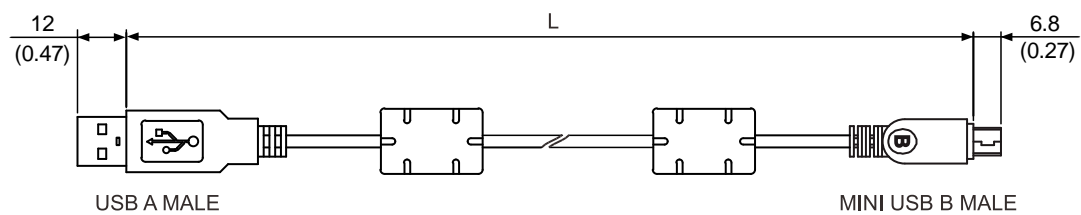

Model number	L	
	mm	inch
UC-PRG015-01A	1500 ± 100	59 ± 4
UC-PRG030-01A	3000 ± 100	118 ± 4

B

### B.18 Position signal converter box

Delta model number: ASD-IF-EN0A20

B

The accessory pack includes a position signal converter box and a 26-pin connector. For details about the usage, refer to Chapter 11 Linear Motor and Third-Party Motor.

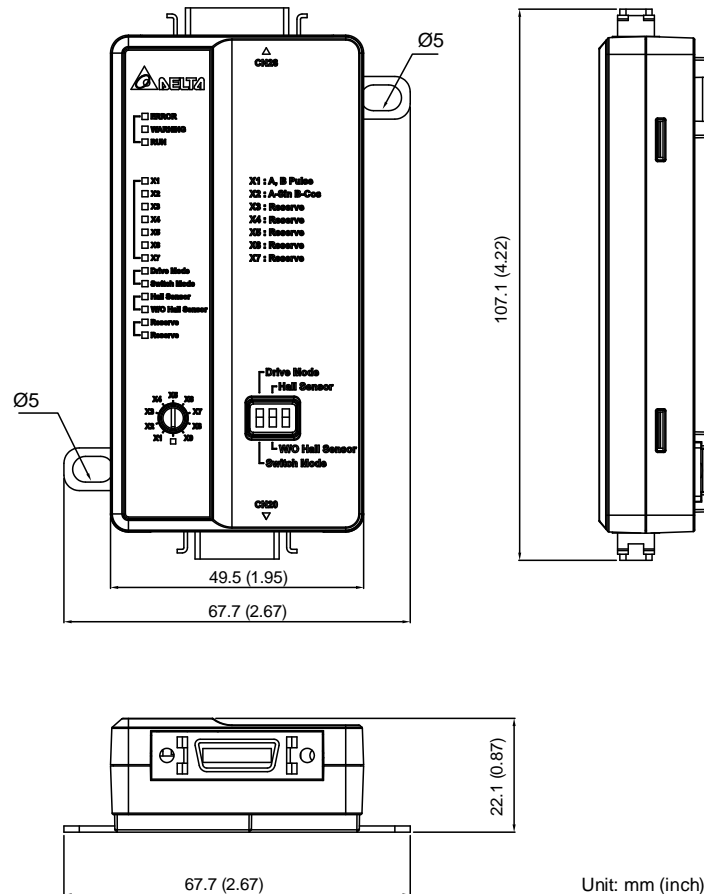

Unit: mm (inch)

Other accessories are sold separately:

#### 20-pin connector

Delta model number: ASD-CN5C0020

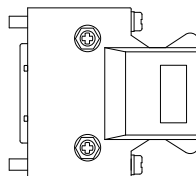

## B.19 Optional accessories

### ■ 220V models

#### F40 - F80 motors

Cable type	Connector type		Accessory	ECM-A3 and ECM-B3 motors			
-	Non-waterproof	-	Encoder connector (servo drive end)	ACS3-CNENC200			
-	Non-waterproof	Standard	Power connector (without brake)	ACS3-CAPW1000			
			Power connector (with brake)	ACS3-CAPW2000			
			Encoder connector (motor end)	ACS3-CAEN0000			
	Waterproof	CHOGORI	Power connector (without brake)	ACS3-CNPW1A00			
			Power connector (with brake)	ACS3-CNPW2A00			
			Encoder connector (motor end)	ACS3-CNEN2A00			
		Bulkhead	Power connector - towards motor shaft (with brake)	ACS3-AFPWSS00			
			Power connector - towards encoder (with brake)	ACS3-ABPWSS00			
			Encoder connector (motor end)	ACS3-AFEASA00			
			Power cable (without brake)	ACS3-CAPW11XX			
Standard	Non-waterproof	Standard	Power cable (with brake)	ACS3-CAPW21XX			
			Encoder cable (incremental type)	ACS3-CAEN01XX			
			Encoder cable (absolute type)	ACS3-CAEA01XX			
			Power cable (without brake)	ACS3-CAPW51XX			
	Waterproof	CHOGORI	Power cable (with brake)	ACS3-CAPW61XX			
			Encoder cable (incremental type)	ACS3-CAEN11XX			
			Encoder cable (absolute type)	ACS3-CAEA11XX			
			Power cable - towards motor shaft (without brake)	ACS3-AFPWSRXX			
		Bulkhead	Power cable - towards motor shaft (with brake)	ACS3-AFPWSSXX			
			Power cable - towards encoder (without brake)	ACS3-ABPWSRXX			
			Power cable - towards encoder (with brake)	ACS3-ABPWSSXX			
			Encoder cable - towards motor shaft (incremental type)	ACS3-AFEASIXX			
			Encoder cable - towards motor shaft (absolute type)	ACS3-AFEASAXX			
			Encoder cable - towards encoder (incremental type)	ACS3-ABEASIXX			
			Encoder cable - towards encoder (absolute type)	ACS3-ABEASAXX			
			Flexible	Non-waterproof	Standard	Power cable (without brake)	ACS3-CAPF11XX
						Power cable (with brake)	ACS3-CAPF21XX
						Encoder cable (incremental type)	ACS3-CAEF01XX
						Encoder cable (absolute type)	ACS3-CAEB01XX
				Waterproof	CHOGORI	Power cable (without brake)	ACS3-CAPF51XX
Power cable (with brake)	ACS3-CAPF61XX						
Encoder cable (incremental type)	ACS3-CAEF11XX						
Encoder cable (absolute type)	ACS3-CAEB11XX						
Bulkhead	Power cable - towards motor shaft (without brake)	ACS3-AFPRSRXX					
	Power cable - towards motor shaft (with brake)	ACS3-AFPRSSXX					
	Power cable - towards encoder (without brake)	ACS3-ABPRSRXX					
	Power cable - towards encoder (with brake)	ACS3-ABPRSSXX					
	Encoder cable - towards motor shaft (incremental type)	ACS3-AFERSIXX					
	Encoder cable - towards motor shaft (absolute type)	ACS3-AFERSAXX					
	Encoder cable - towards encoder (incremental type)	ACS3-ABERSIXX					
	Encoder cable - towards encoder (absolute type)	ACS3-ABERSAXX					

Note:

1. XX indicates the cable length. 03 = 3 m; 05 = 5 m; 10 = 10 m; 20 = 20 m.
2. ECM-A3 series servo motors do not support bulkhead connectors.

# B

B

F100 - F130 motors

Cable type	Connector type			Accessory	ECM-B3M-C□1010 ECM-B3M-C□1015 ECM-B3M-C□1020 ECM-B3M-E□1310 ECM-B3M-E□1315 ECM-B3H-F□1308 ECM-B3H-F□1313	ECM-B3M-E□1320 ECM-B3H-F□1318			
	Non-waterproof								
-	Non-waterproof	-	-	Encoder connector (servo drive end)	ACS3-CNENC200				
-	Waterproof	Military connector - straight	-	Power connector (without brake)	ACS3-CAPWA000				
			Bayonet	Brake connector	ACS3-CABRA000				
				Encoder connector (motor end)	ACS3-CAENA000				
			Threaded	Brake connector	ACS3-CABRM000				
				Encoder connector (motor end)	ACS3-CAENM000				
			Military connector - right angle	-	Power connector (without brake)	ACS3-CRPWA000			
		Bayonet		Brake connector	ACS3-CRBRA000				
				Encoder connector (motor end)	ACS3-CRENA000				
		Threaded		Brake connector	ACS3-CRBRM000				
				Encoder connector (motor end)	ACS3-CRENM000				
		Standard		Waterproof	Military connector - straight	-	Power cable (without brake)	ACS3-CAPWA2XX	ACS3-CAPWA3XX
			Bayonet			Brake cable	ACS3-CABRA1XX		
Encoder cable (incremental type)	ACS3-CAENA1XX								
Threaded	Encoder cable (absolute type)		ACS3-CAEAA1XX						
	Brake cable		ACS3-CABRM1XX						
Encoder cable (incremental type)	ACS3-CAENM1XX								
	Encoder cable (absolute type)		ACS3-CAEAM1XX						
Military connector - right angle	-		Power cable (without brake)			ACS3-CRPWA2XX	ACS3-CRPWA3XX		
	Bayonet		Brake cable			ACS3-CRBRA1XX			
			Encoder cable (incremental type)			ACS3-CRENA1XX			
	Threaded		Encoder cable (absolute type)			ACS3-CREAA1XX			
			Brake cable			ACS3-CRBRM1XX			
	Encoder cable (incremental type)		ACS3-CRENM1XX						
			Encoder cable (absolute type)		ACS3-CREAM1XX				
	Flexible		Waterproof		Military connector - straight	-	Power cable (without brake)	ACS3-CAPFA2XX	ACS3-CAPFA3XX
						Bayonet	Brake cable	ACS3-CABFA1XX	
							Encoder cable (incremental type)	ACS3-CAEFA1XX	
						Threaded	Encoder cable (absolute type)	ACS3-CAEBA1XX	
							Brake cable	ACS3-CABFM1XX	
Encoder cable (incremental type)						ACS3-CAEFM1XX			
					Encoder cable (absolute type)	ACS3-CAEBM1XX			
Military connector - right angle					-	Power cable (without brake)	ACS3-CRPFA2XX	ACS3-CRPFA3XX	
					Bayonet	Brake cable	ACS3-CRBF1XX		
						Encoder cable (incremental type)	ACS3-CREFA1XX		
		Threaded		Encoder cable (absolute type)	ACS3-CREBA1XX				
				Brake cable	ACS3-CRBFM1XX				
	Encoder cable (incremental type)	ACS3-CREFM1XX							
Encoder cable (absolute type)	ACS3-CREBM1XX								

Note:

1. XX indicates the cable length. 03 = 3 m; 05 = 5 m; 10 = 10 m; 20 = 20 m.
2. Use bayonet connectors for motors with bayonet or threaded bayonet connectors.
3. Use threaded connectors for motors with threaded bayonet connectors.

**F180 4.5 kW (or below) motors**

Cable type	Connector type			Accessory	ECM-B3M-E□1820	ECM-B3M-F□1830	ECM-B3M-F□1845			
-	Non-waterproof	-	-	Encoder connector (servo drive end)		ACS3-CNENC200				
-	Waterproof	Military connector - straight	Bayonet	Power connector (without brake)		ACS3-CAPWC000				
				Brake connector		ACS3-CABRA000				
			Threaded	Encoder connector (motor end)		ACS3-CAENA000				
				Brake connector		ACS3-CABRM000				
		Military connector - right angle	Bayonet	Power connector (without brake)		ACS3-CRPWC000				
				Brake connector		ACS3-CRBRA000				
			Threaded	Encoder connector (motor end)		ACS3-CRENA000				
				Brake connector		ACS3-CRBRM000				
				Encoder connector (motor end)		ACS3-CRENM000				
Standard	Waterproof	Military connector - straight	Bayonet	Power cable (without brake)	ACS3-CAPWC3XX	ACS3-CAPWC4XX	ACS3-CAPWC5XX			
				Brake cable		ACS3-CABRA1XX				
			Threaded	Encoder cable (incremental type)		ACS3-CAENA1XX				
				Encoder cable (absolute type)		ACS3-CAEAA1XX				
				Brake cable		ACS3-CABRM1XX				
				Encoder cable (incremental type)		ACS3-CAENM1XX				
			Military connector - right angle	Bayonet	Power cable (without brake)	ACS3-CRPWC3XX	ACS3-CRPWC4XX	ACS3-CRPWC5XX		
					Brake cable		ACS3-CRBRA1XX			
				Threaded	Encoder cable (incremental type)		ACS3-CRENA1XX			
					Encoder cable (absolute type)		ACS3-CREAA1XX			
		Brake cable				ACS3-CRBRM1XX				
		Encoder cable (incremental type)				ACS3-CRENM1XX				
						ACS3-CREAM1XX				
		Flexible		Waterproof	Military connector - straight	Bayonet	Power cable (without brake)	ACS3-CAPFC3XX	ACS3-CAPFC4XX	ACS3-CAPFC5XX
							Brake cable		ACS3-CABFA1XX	
						Threaded	Encoder cable (incremental type)		ACS3-CAEFA1XX	
			Encoder cable (absolute type)					ACS3-CAEBA1XX		
			Brake cable					ACS3-CABFM1XX		
			Encoder cable (incremental type)					ACS3-CAEFM1XX		
			Military connector - right angle			Bayonet	Power cable (without brake)	ACS3-CRPFC3XX	ACS3-CRPFC4XX	ACS3-CRPFC5XX
Brake cable							ACS3-CRBFA1XX			
Threaded	Encoder cable (incremental type)						ACS3-CREFA1XX			
	Encoder cable (absolute type)						ACS3-CREBA1XX			
	Brake cable					ACS3-CRBFM1XX				
	Encoder cable (incremental type)					ACS3-CREFM1XX				
						ACS3-CREBM1XX				

Note:

1. XX indicates the cable length. 03 = 3 m; 05 = 5 m; 10 = 10 m; 20 = 20 m.
2. Use bayonet connectors for motors with bayonet or threaded bayonet connectors.
3. Use threaded connectors for motors with threaded bayonet connectors.

B

**F180 5.5 kW (or above) and F220 motors**

B

Cable type	Connector type			Accessory	ECM-B3M-F□1855 ECM-B3M-F□1875 ECM-B3M-F□221B	ECM-B3M-F□221F	
	Non-waterproof						
-	Non-waterproof	-	-	Encoder connector (servo drive end)	ACS3-CNENC200		
-	Waterproof	Military connector - straight	Bayonet	-	Power connector (without brake)	ACS3-CAPWE000	
				-	Brake connector	ACS3-CABRA000	
				-	Encoder connector (motor end)	ACS3-CAENA000	
			Threaded	-	Brake connector	ACS3-CABRM000	
				-	Encoder connector (motor end)	ACS3-CAENM000	
				-	Power connector (without brake)	ACS3-CRPWE000	
		Military connector - right angle	Bayonet	-	Brake connector	ACS3-CRBRA000	
				-	Encoder connector (motor end)	ACS3-CRENA000	
				-	Brake connector	ACS3-CRBRM000	
			Threaded	-	Encoder connector (motor end)	ACS3-CRENM000	
				-	Power cable (without brake)	ACS3-CAPWE6XX	ACS3-CAPWE8XX
				-	Brake cable	ACS3-CABRA1XX	
Standard	Waterproof	Military connector - straight	Bayonet	-	Encoder cable (incremental type)	ACS3-CAENA1XX	
				-	Encoder cable (absolute type)	ACS3-CAEAA1XX	
				-	Brake cable	ACS3-CABRM1XX	
			Threaded	-	Encoder cable (incremental type)	ACS3-CAENM1XX	
				-	Encoder cable (absolute type)	ACS3-CAEAM1XX	
				-	Power cable (without brake)	ACS3-CRPWE6XX	ACS3-CRPWE8XX
		Military connector - right angle	Bayonet	-	Brake cable	ACS3-CRBRA1XX	
				-	Encoder cable (incremental type)	ACS3-CRENA1XX	
				-	Encoder cable (absolute type)	ACS3-CREAA1XX	
			Threaded	-	Brake cable	ACS3-CRBRM1XX	
				-	Encoder cable (incremental type)	ACS3-CRENM1XX	
				-	Encoder cable (absolute type)	ACS3-CREAM1XX	
Flexible	Waterproof	Military connector - straight	Bayonet	-	Power cable (without brake)	ACS3-CAPFE6XX	ACS3-CAPFE8XX
				-	Brake cable	ACS3-CABFA1XX	
				-	Encoder cable (incremental type)	ACS3-CAEFA1XX	
			Threaded	-	Encoder cable (absolute type)	ACS3-CAEBA1XX	
				-	Brake cable	ACS3-CABFM1XX	
				-	Encoder cable (incremental type)	ACS3-CAEFM1XX	
		Military connector - right angle	Bayonet	-	Encoder cable (absolute type)	ACS3-CAEBM1XX	
				-	Power cable (without brake)	ACS3-CRPFE6XX	ACS3-CRPFE8XX
				-	Brake cable	ACS3-CRBFA1XX	
			Threaded	-	Encoder cable (incremental type)	ACS3-CREFA1XX	
				-	Encoder cable (absolute type)	ACS3-CREBA1XX	
				-	Brake cable	ACS3-CRBFM1XX	
-	Encoder cable (incremental type)	ACS3-CREFM1XX					
-	Encoder cable (absolute type)	ACS3-CREBM1XX					

Note:

1. XX indicates the cable length. 03 = 3 m; 05 = 5 m; 10 = 10 m; 20 = 20 m.
2. Use bayonet connectors for motors with bayonet or threaded bayonet connectors.
3. Use threaded connectors for motors with threaded bayonet connectors.

## ■ 400V models

### F40 - F80 motors

Cable type	Connector type		Accessory	ECM-B3 motors
-	Non-waterproof	-	Encoder connector (servo drive end)	ACS3-CNENC200
-	Non-waterproof	Standard	Power connector (without brake)	ACS3-CAPW1000
			Power connector (with brake)	ACS3-CAPW2000
			Encoder connector (motor end)	ACS3-CAEN0000
Standard	Non-waterproof	Standard	Power cable (without brake)	ACS3-CAPW31XX
			Power cable (with brake)	ACS3-CAPW21XX
Encoder cable (incremental type)			ACS3-CAEN01XX	
Encoder cable (absolute type)			ACS3-CAEA01XX	
Flexible			Power cable (without brake)	ACS3-CAPF31XX
			Power cable (with brake)	ACS3-CAPF21XX
			Encoder cable (incremental type)	ACS3-CAEF01XX
			Encoder cable (absolute type)	ACS3-CAEB01XX

Note: XX indicates the cable length. 03 = 3 m; 05 = 5 m; 10 = 10 m; 20 = 20 m.

B



B

F100 - F130 motors

Cable type	Connector type			Accessory	ECM-B3M-J□1010 ECM-B3M-J□1015 ECM-B3M-J□1020 ECM-B3M-K□1310 ECM-B3M-K□1315 ECM-B3M-K□1320 ECM-B3H-L□1308 ECM-B3H-L□1313 ECM-B3H-L□1318			
	Non-waterproof	-	-					
-	Non-waterproof	-	-	Encoder connector (servo drive end)	ACS3-CNENC200			
-	Waterproof	Military connector - straight	-	Power connector (without brake)	ACS3-CAPWA000			
			Bayonet	Brake connector	ACS3-CABRA000			
				Encoder connector (motor end)	ACS3-CAENA000			
			Threaded	Brake connector	ACS3-CABRM000			
				Encoder connector (motor end)	ACS3-CAENM000			
			Military connector - right angle	-	Power connector (without brake)	ACS3-CRPWA000		
		Bayonet		Brake connector	ACS3-CRBRA000			
				Encoder connector (motor end)	ACS3-CRENA000			
		Threaded		Brake connector	ACS3-CRBRM000			
				Encoder connector (motor end)	ACS3-CRENM000			
		Standard		Waterproof	Military connector - straight	-	Power cable (without brake)	ACS3-CAPWA2XX
			Bayonet			Brake cable	ACS3-CABRA1XX	
Encoder cable (incremental type)	ACS3-CAENA1XX							
Encoder cable (absolute type)	ACS3-CAEAA1XX							
Threaded	Brake cable		ACS3-CABRM1XX					
	Encoder cable (incremental type)		ACS3-CAENM1XX					
Encoder cable (absolute type)	ACS3-CAEAM1XX							
Military connector - right angle	-		Power cable (without brake)			ACS3-CRPWA2XX		
	Bayonet		Brake cable			ACS3-CRBRA1XX		
			Encoder cable (incremental type)			ACS3-CRENA1XX		
	Encoder cable (absolute type)		ACS3-CREAA1XX					
	Threaded		Brake cable			ACS3-CRBRM1XX		
			Encoder cable (incremental type)		ACS3-CRENM1XX			
	Encoder cable (absolute type)		ACS3-CREAM1XX					
	Flexible		Waterproof		Military connector - straight	-	Power cable (without brake)	ACS3-CAPFA2XX
						Bayonet	Brake cable	ACS3-CABFA1XX
							Encoder cable (incremental type)	ACS3-CAEFA1XX
						Encoder cable (absolute type)	ACS3-CAEBA1XX	
						Threaded	Brake cable	ACS3-CABFM1XX
Encoder cable (incremental type)							ACS3-CAEFM1XX	
Encoder cable (absolute type)					ACS3-CAEBM1XX			
Military connector - right angle					-	Power cable (without brake)	ACS3-CRPFA2XX	
					Bayonet	Brake cable	ACS3-CRBFA1XX	
						Encoder cable (incremental type)	ACS3-CREFA1XX	
		Encoder cable (absolute type)		ACS3-CREBA1XX				
		Threaded		Brake cable	ACS3-CRBFM1XX			
	Encoder cable (incremental type)		ACS3-CREFM1XX					
Encoder cable (absolute type)	ACS3-CREBM1XX							

Note:

1. XX indicates the cable length. 03 = 3 m; 05 = 5 m; 10 = 10 m; 20 = 20 m.
2. Use bayonet connectors for motors with bayonet or threaded bayonet connectors.
3. Use threaded connectors for motors with threaded bayonet connectors.

**F180 4.5 kW (or below) motors**

Cable type	Connector type			Accessory	ECM-B3M-K□1820 ECM-B3M-L□1830 ECM-B3M-L□1845			
-	Non-waterproof	-	-	Encoder connector (servo drive end)	ACS3-CNENC200			
-	Waterproof	Military connector - straight	-	Power connector (without brake)	ACS3-CAPWC000			
			Bayonet	Brake connector	ACS3-CABRA000			
				Encoder connector (motor end)	ACS3-CAENA000			
			Threaded	Brake connector	ACS3-CABRM000			
				Encoder connector (motor end)	ACS3-CAENM000			
			Military connector - right angle	-	Power connector (without brake)	ACS3-CRPWC000		
		Bayonet		Brake connector	ACS3-CRBRA000			
				Encoder connector (motor end)	ACS3-CRENA000			
		Threaded		Brake connector	ACS3-CRBRM000			
				Encoder connector (motor end)	ACS3-CRENM000			
		Standard		Waterproof	Military connector - straight	-	Power cable (without brake)	ACS3-CAPWC3XX
			Bayonet			Brake cable	ACS3-CABRA1XX	
Encoder cable (incremental type)	ACS3-CAENA1XX							
Encoder cable (absolute type)	ACS3-CAEAA1XX							
Threaded	Brake cable		ACS3-CABRM1XX					
	Encoder cable (incremental type)		ACS3-CAENM1XX					
	Encoder cable (absolute type)		ACS3-CAEAM1XX					
Military connector - right angle	-		Power cable (without brake)			ACS3-CRPWC3XX		
	Bayonet		Brake cable			ACS3-CRBRA1XX		
			Encoder cable (incremental type)			ACS3-CRENA1XX		
			Encoder cable (absolute type)			ACS3-CREAA1XX		
	Threaded		Brake cable			ACS3-CRBRM1XX		
			Encoder cable (incremental type)		ACS3-CRENM1XX			
			Encoder cable (absolute type)		ACS3-CREAM1XX			
	Flexible		Waterproof		Military connector - straight	-	Power cable (without brake)	ACS3-CAPFC3XX
						Bayonet	Brake cable	ACS3-CABFA1XX
							Encoder cable (incremental type)	ACS3-CAEFA1XX
							Encoder cable (absolute type)	ACS3-CAEBA1XX
						Threaded	Brake cable	ACS3-CABFM1XX
Encoder cable (incremental type)							ACS3-CAEFM1XX	
Encoder cable (absolute type)							ACS3-CAEBM1XX	
Military connector - right angle						-	Power cable (without brake)	ACS3-CRPFC3XX
						Bayonet	Brake cable	ACS3-CRBFA1XX
							Encoder cable (incremental type)	ACS3-CREFA1XX
		Encoder cable (absolute type)		ACS3-CREBA1XX				
		Threaded		Brake cable		ACS3-CRBFM1XX		
				Encoder cable (incremental type)	ACS3-CREFM1XX			
				Encoder cable (absolute type)	ACS3-CREBM1XX			

Note:

1. XX indicates the cable length. 03 = 3 m; 05 = 5 m; 10 = 10 m; 20 = 20 m.
2. Use bayonet connectors for motors with bayonet or threaded bayonet connectors.
3. Use threaded connectors for motors with threaded bayonet connectors.

B

**F180 5.5 kW (or above) and F220 motors**

B

Cable type	Connector type			Accessory	ECM-B3M-L□1855 ECM-B3M-L□1875 ECM-B3M-L□221B ECM-B3M-L□221F			
	Non-waterproof	-	-					
-	Non-waterproof	-	-	Encoder connector (servo drive end)	ACS3-CNENC200			
-	Waterproof	Military connector - straight	-	Power connector (without brake)	ACS3-CAPWE000			
			Bayonet	Brake connector	ACS3-CABRA000			
				Encoder connector (motor end)	ACS3-CAENA000			
			Threaded	Brake connector	ACS3-CABRM000			
				Encoder connector (motor end)	ACS3-CAENM000			
			Military connector - right angle	-	Power connector (without brake)	ACS3-CRPWE000		
		Bayonet		Brake connector	ACS3-CRBRA000			
				Encoder connector (motor end)	ACS3-CRENA000			
		Threaded		Brake connector	ACS3-CRBRM000			
				Encoder connector (motor end)	ACS3-CRENM000			
		Standard		Waterproof	Military connector - straight	-	Power cable (without brake)	ACS3-CAPWE6XX
			Bayonet			Brake cable	ACS3-CABRA1XX	
Encoder cable (incremental type)	ACS3-CAENA1XX							
Encoder cable (absolute type)	ACS3-CAEAA1XX							
Threaded	Brake cable		ACS3-CABRM1XX					
	Encoder cable (incremental type)		ACS3-CAENM1XX					
Encoder cable (absolute type)	ACS3-CAEAM1XX							
Military connector - right angle	-		Power cable (without brake)			ACS3-CRPWE6XX		
	Bayonet		Brake cable			ACS3-CRBRA1XX		
			Encoder cable (incremental type)			ACS3-CRENA1XX		
	Encoder cable (absolute type)		ACS3-CREAA1XX					
	Threaded		Brake cable			ACS3-CRBRM1XX		
			Encoder cable (incremental type)		ACS3-CRENM1XX			
	Encoder cable (absolute type)		ACS3-CREAM1XX					
	Flexible		Waterproof		Military connector - straight	-	Power cable (without brake)	ACS3-CAPFE6XX
						Bayonet	Brake cable	ACS3-CABFA1XX
							Encoder cable (incremental type)	ACS3-CAEFA1XX
						Encoder cable (absolute type)	ACS3-CAEBA1XX	
						Threaded	Brake cable	ACS3-CABFM1XX
Encoder cable (incremental type)							ACS3-CAEFM1XX	
Encoder cable (absolute type)					ACS3-CAEBM1XX			
Military connector - right angle					-	Power cable (without brake)	ACS3-CRPFE6XX	
					Bayonet	Brake cable	ACS3-CRBFA1XX	
						Encoder cable (incremental type)	ACS3-CREFA1XX	
		Encoder cable (absolute type)		ACS3-CREBA1XX				
		Threaded		Brake cable	ACS3-CRBFM1XX			
	Encoder cable (incremental type)		ACS3-CREFM1XX					
Encoder cable (absolute type)	ACS3-CREBM1XX							

Note:

1. XX indicates the cable length. 03 = 3 m; 05 = 5 m; 10 = 10 m; 20 = 20 m.
2. Use bayonet connectors for motors with bayonet or threaded bayonet connectors.
3. Use threaded connectors for motors with threaded bayonet connectors.

# Revision History

Release date	Version	Chapter	Revision contents
January, 2024	V10.0 (Tenth edition)	-	400V series servo drives have acquired the TUV certificate. Modify the terms for consistency: The term “quick connector” is changed to “standard connector”. The term “IP67 waterproof connector” is changed to “CHOGORI connector”. The term “IP67 waterproof military connector” is changed to “military connector”. The term “angle connector” is changed to “right angle connector”.
		2.5	220V models: Add the specifications of the circuit breaker, magnetic contactor, and fuse for the control circuit power. Modify the fuse specification for the main circuit power.
		2.10	Update the precautions for the use of cables.
		3.1.4 3.1.5	Brake connectors and encoder connectors for the F100 - F220 motors: Remove the model names for SUNCHU connectors and contacts. Add the model names for Delta threaded connectors. Add the model names for DDK connector contacts.
		3.1.6.1	Add the specifications of wire diameter and wire ferrules for the locked rotor condition.
		3.10.4	Modify the standards for STO.
		6.7.4	Change the unit of the motor encoder feedback position to PUU.
		8.3	Modify the parameter descriptions for P1.073 and P3.013.

Release date	Version	Chapter	Revision contents
January, 2024	V10.0 (Tenth edition)	10.1.3	Add the encoder cable for motors with bulkhead connectors and simplify the wiring descriptions.
		A.3.1.1	Add the specifications of the high inertia F80 and below motors.
		A.3.2.1	Add the torque features (T-N curves) of the high inertia 220V motors (ECM-B3H-C series).
		A.3.5.1	Add the dimensions of the high inertia 220V motors (ECM-B3H-C series).
		B.1.5	Add the brake connectors (threaded) for the F100 - F220 motors.
		B.2.5	Add the brake cables with threaded connectors for the F100 - F220 motors.
		B.3.2	Add the encoder connectors (threaded) for the F100 - F220 motors.
		B.4.2 B.5.2	Add the encoder cables with threaded connectors for the F100 - F220 motors.
		B.19	Update the lists of optional accessories.
June, 2023	V9.0 (Ninth edition)	Preface	Add information about the replacement of motor parts.
		1.2	Update the functional safety certification marks on the servo drive's nameplate.
		2.4.2	Remove the warning for motor installation.
		2.5	Add the maximum fault loop impedance table for the ASDA-A3 220V servo drives.
		3.1.4.1 3.1.5.1	Add information about the bulkhead connectors.
		3.1.6.1	Add the wire diameters for the attached terminals of the Delta connectors.
		3.1.6.4	Add the specifications of the encoder cables for the motors with bulkhead connectors.
		3.1.6.5	Add the specifications of the power cables for the motors with bulkhead connectors.
		3.1.7.1	Add the wiring instructions for the bulkhead connectors.
		3.1.7.3	Add the diameters of rubber rings and tightening torques for the bulkhead connectors.

Release date	Version	Chapter	Revision contents
June, 2023	V9.0 (Ninth edition)	3.4.1.1 3.4.1.3	Optimize the warnings for pulse input wiring.
		3.5	Add the pin assignment for the bulkhead connectors of the encoder cables.
		3.10	Remove the SIL2 content for the 220V servo drives and merge the content of Section 3.11 into Section 3.10.
		5	Add the restrictions and specifications for linear motor tuning.
		8	Correct the unit for PM.004. Modify the description for PM.045. Modify the description for DI: 0x06.
		11.7.1	Modify the suggested jog speed of the linear motor for weight estimation.
		14	Correct the descriptions for AL283 and AL285. Correct the alarm clearing method for AL3CF.
		A	Add information about the pollution degree for the 220V servo drives. Update information about the IP rating and power system for the 220V servo drives. Add the IP rating requirement of the cabinet for installing the 220V servo drives. Correct the torque features (T-N curves) of these motors: ECM-B3M-C□0807, ECM-B3H-F□1318, and ECM-B3H-L□1318. Correct the model names of the 220V (F180 & F220) and 400V (F180 & F220) motors.
		B.1.1	Add the bulkhead connectors.
		B.2.1	Add the power cables for the motors with bulkhead connectors.
		B.3.1	Modify the model number of the standard connector. Add the bulkhead connectors.
		B.4.1 B.5.1	Add the encoder cables for the motors with bulkhead connectors.
		B.5.2	Modify the model number of the right angle military connector.
		B.19	Add the tables of optional accessories.

Release date	Version	Chapter	Revision contents
March, 2023	V8.0 (Eighth edition)	-	Modify the terms: The term “brake resistor” is changed to “regenerative resistor”. The term “brake unit” is changed to “regenerative unit”.
		1.2.2	Add the specification of bulkhead connectors. Add information about the applicable models in the note.
		2.5	Add the maximum fault loop impedance table for the ASDA-A3 400V servo drives.
		2.9	Modify the wiring diagram of the magnetic brake.
		3.11.4	Update the PFH values.
		7.1.2	Modify “Cmd_O(Pulse) – Fb_Pulse < P1.054” to “ Cmd_O(Pulse) – Fb_Pulse  > P1.054” for Figure 7.1.2.3 and Figure 7.1.2.4.
		8	Modify the control mode of P2.104.
		11.2.3.1	Add the specification of the maximum resolution for the rotary encoders and linear scales supported by the servo drives.
		12 & 13	Modify the maximum setting range of OD 6099h.
		14	Modify the method to clear AL001.
October, 2022	V7.0 (Seventh edition)	Preface	Add the Sections of Disposal instructions, Inspection and Maintenance, and Replacing the parts.
		All	Add information about the ASDA-A3 400V series servo drives.

Release date	Version	Chapter	Revision contents
October, 2022	V7.0 (Seventh edition)	All	<p>Add information about the following models.</p> <p>ASD-A3-4523-□</p> <p>ASD-A3-5523-□</p> <p>ASD-A3-7523-□</p> <p>ASD-A3-1B23-□</p> <p>ASD-A3-1F23-□</p> <p>ECM-B3M-C<sup>2</sup>0810<sup>3</sup><sup>4</sup>1</p> <p>ECM-B3M-C<sup>2</sup>1010<sup>3</sup><sup>4</sup>1</p> <p>ECM-B3M-C<sup>2</sup>1015<sup>3</sup><sup>4</sup>1</p> <p>ECM-B3M-C<sup>2</sup>1020<sup>3</sup><sup>4</sup>1</p> <p>ECM-B3M-F<sup>2</sup>1845<sup>3</sup><sup>4</sup>1</p> <p>ECM-B3M-F<sup>2</sup>1855<sup>3</sup><sup>4</sup>1</p> <p>ECM-B3M-F<sup>2</sup>1875<sup>3</sup><sup>4</sup>1</p> <p>ECM-B3M-F<sup>2</sup>221B<sup>3</sup><sup>4</sup>1</p> <p>ECM-B3M-F<sup>2</sup>221F<sup>3</sup><sup>4</sup>1</p> <p>ECM-B3H-F<sup>2</sup>1308<sup>3</sup><sup>4</sup>1</p> <p>ECM-B3H-F<sup>2</sup>1313<sup>3</sup><sup>4</sup>1</p> <p>ECM-B3H-F<sup>2</sup>1318<sup>3</sup><sup>4</sup>1</p>
		All	<p>Modify the terms:</p> <p>The term “Index Position command” is changed to “Rotary Axis Position command”.</p> <p>“Indexing coordinate system” is changed to “Rotary axis position system”.</p>
		2.8	Modify the maximum regenerative energy of the capacitance $E_c$ for 100 W, 750 W and 2 kW servo drives.
		3.1.3	Change ALRM_RY_B (normally closed contact) into ALRM_RY_A (normally open contact).
		3.1.6.4	Add the section of encoder cable specifications.
		3.1.6.5	Add the section of power cable specifications.
		3.1.6.6	Add the section of flexible cable specifications.
		3.1.7.2	Add the waterproof connector wiring instructions for F100 - F180 models.
		3.1.7.3	Add the waterproof connector specifications.
		3.10	Modify the pin names for the STO signals.
		4.3.5	Add monitoring variables 27 - 31.
		5	Optimize the contents to improve the tuning experience.



Release date	Version	Chapter	Revision contents
October, 2022	V7.0 (Seventh edition)	6.3.6	Modify the control structure diagram for speed loop gain adjustment.
		7.2.2	Modify Figure 7.2.2.4 Application example for high-speed capture function.
		8.3	Add the parameter P1.120. Add the parameter descriptions for P1.000, P1.012, P1.013, P1.014, P2.027, P2.032, P0.063, P2.065, P2.066, P2.068, P2.069, P0.079, P0.071, P2.084, P2.112, P2.113, P2.114, P2.121, P2.125, P2.126, P3.009, P3.012, P3.018, P4.000, P4.027, P5.097, PM.009, and PM.012. Modify the parameters P2.052, P2.060, P2.061, and P2.062. Correct the descriptions for DIs 0x14 - 0x17. Add DO 0x41. Add monitoring variables 27, 42, -145, -169, -201, -202, -206, -207, and -213.
		8.3	Modify the descriptions for monitoring variables 28 and 82.
		11	The CN2 connector supports Nikon motors.
		11.2.3.2	Added the information of the supported communication format for the motors.
		11.3	Update the ASDA-Soft software screenshots.
		11.7.4	Add the initial magnetic field detection function.
		12	Add the CANopen OD 60FEh and the function of homing on the hard stop. Modify the unit of OD6075. Add the unit information of linear motors for OD6099.
		12.3	Modify the CANopen architecture diagrams.
		13	Add the EtherCAT OD 60FEh and the function of homing on the hard stop. Modify the unit of OD6075. Add the unit information of linear motors for OD6099.
		13.2.2.1	Modify the Delay formula.
		13.3	Modify the EtherCAT architecture diagrams.

Release date	Version	Chapter	Revision contents
October, 2022	V7.0 (Seventh edition)	13.3.8	Modify the timing diagrams of the Touch Probe function.
		14	Add the alarms AL02C, AL02F, AL087, and ALC31. Correct / modify the alarm descriptions for AL001, AL024, AL033, AL035, AL066, AL06B, AL0A6, and AL255.
		A	Modify the resolution of analog command input.
		A.1.1.1	Add the inrush current and control power specifications of the servo drives. Modify the input current specifications. Correct the maximum instantaneous output current specifications for 1.5 kW and 3 kW servo drives.
		A.3.5	Modify the dimension diagrams for motors with the frame size of 80 mm or below and motors with the frame size of 130 mm.
January, 2021	V6.0 (Sixth edition)		Add information about the A3-E series servo drives and B3 series servo motors.
		1.2.1	Add notes for the applicable power supply of servo motors.
		1.2.2	Modify and add the descriptions for encoder types. Add the descriptions for shaft diameter and connector types. Add the description for the special code. Add the contents of B3 series servo motors.
		1.3.1	The table of combination of servo drive and motor provides the torque specifications.
		2.2	Add the description for the B3 series servo motors. Add the description of airflow velocity for installing the servo drives.
		2.4	Add one description to the handling, mounting, and storage precautions.

Release date	Version	Chapter	Revision contents
January, 2021	V6.0 (Sixth edition)	3	Change of pulse names: SIGN is changed to SIGN+, /SIGN is changed to SIGN-, PULSE is changed to PULSE+, and /PULSE is changed to PULSE-.
		3.1.3	Optimize the diagram of connecting multiple servo drives in parallel.
		3.1.4	Add the specifications for flexible cables. Add the descriptions about the cables for IP67 waterproof connectors.
		3.1.5	Add the recommended brands for connectors. Add the descriptions about the cables for IP67 waterproof connectors.
		3.1.7	Add the IP67 waterproof connector wiring instructions.
		3.3.1	Add the specification of CN1 tightening torque.
		3.3.2	Optimize the descriptions for default DI/DO signals.
		3.3.4	Optimize the descriptions for default DI/DO signals.
		3.3.6.2	Add the descriptions of the quick connector for A3-E and A3-F models.
		3.4	Add the warnings for CN2 connector.
		3.7	Add the specification of CN5 tightening torque. Add the specifications and wiring descriptions for the CN5 signals.
		3.8.2	Add information about the wiring for the EtherCAT communication connector.
		3.10.4	Modify the status and alarms for the feedback monitor signal.
		3.11.1	Optimize the wiring diagram of Position (PT) control mode - differential pulse signals.
		3.11.2	Optimize the wiring diagram of Position (PT) control mode - open-collector pulse signals.
		4.5.4 4.5.5	Correct the parameter numbers.
5.4	Position feed forward gain (P2.002) can be set when the two degree of freedom control function is enabled.		

Release date	Version	Chapter	Revision contents
January, 2021	V6.0 (Sixth edition)	6.1	Add the description for DMCNET mode. Add the second development platform mode.
		6.3.4	Add the description for switching between analog speed commands.
		6.7	Add the Full-closed loop section.
		8	Modify the parameter descriptions for P0.051, P0.053, P1.000, P1.001, P1.002, P1.003, P1.004, P1.012, P1.013, P1.014, P1.022, P1.032, P1.034, P1.035, P1.036, P1.038, P1.039, P1.040, P1.041, P1.043, P1.044, P1.045, P1.046, P1.057, P1.062, P1.066, P1.072, P1.073, P1.074, P1.075, P1.076, P1.081, P1.097, P2.002, P2.006, P2.008, P2.027, P2.065, P2.066, P2.068, P2.088, P2.094, P2.112, P3.001, P3.007, P3.009, P3.010, P3.011, and P3.012. Add parameters P1.060, P1.061, P1.078, P1.079, P1.080, P1.084, P1.085, P1.105, P1.106, P1.112, P2.081, P2.082, P2.083, P2.084, P2.090, P2.091, P2.092, P2.107, P3.005, P3.017, P3.018, P3.019, P3.022, and P4.044. Add DIs 0x0B and 0x0F. Modify the descriptions for DIs 0x06, 0x0E, and 0x14 to 0x17. Add monitoring variables 032, 033, 082, 115, 119, and -111. Modify monitoring variables 002, 005, 024, 028, 030, -177, and -178. Delete monitoring variables 050, 068, 069, and 121.
		10.1.1	Add and modify the battery specifications.
		10.1.3	Modify the wire colors of the encoder cable. Add the descriptions about the cables for IP67 waterproof connectors.
		10.1.4	Add the battery box cables that connect to the encoders.
		10.2.1	Add the pin definitions of IP67 connector and B3 military connector.
		10.2.2	Modify the battery voltage value causing data loss.

Release date	Version	Chapter	Revision contents
January, 2021	V6.0 (Sixth edition)	10.3.4.1	Modify the signal delay time.
		11	Optimize the chapter contents. Add information about the third-party motors.
		11.2.1	Add the precautions for installing linear motors.
		11.2.2	Add the configuration description for linear motors and rotary motors.
		11.3.1.2	Add the description for motor parameter identification for rotary motors.
		11.5.1	Add the descriptions for installing the Hall sensor.
		11.6	Add the Position signal converter box section.
		12.1.2	Modify the connector illustration.
		12.3	Modify the contents of the architecture diagrams.
		12.4.3	Add OD 6072 and OD 607D.
		13	Add the EtherCAT Mode chapter.
		14.2	Modify the alarm descriptions for AL003, AL007, AL009, AL014, AL015, AL016, AL020, AL028, AL031, AL040, AL041, AL044, AL052, AL054, AL055, AL058, AL05B, AL05C, AL060, AL061, AL062, AL069, AL06A, AL070, AL072, AL083, AL086, AL088, AL08B, AL08C, AL111, AL112, AL121 to AL132, AL185, AL186, AL201, AL217, AL235, AL237, AL301, AL304, AL35F, AL3CF, AL3E2, AL3E3, and AL400. Add alarms AL010, AL02A, AL02B, AL032, AL033, AL036, AL048, AL057, AL05D, AL05E, AL063, AL064, AL066, AL06B, AL06E, AL06F, AL071, AL07A, AL09C, AL0A6, AL113, AL170, AL180, AL203, AL211, AL21B, AL21D, AL221, AL223, AL22D, AL239, AL23F, AL245, AL247, AL251, AL255, AL257, AL25B, AL25F, AL261, AL262, AL302, AL303, AL3E1, AL422, AL510, AL520, ALD00 to ALD31, ALE00 to ALE07, ALF21, and ALF22. Delete the alarm AL019.
		A	Add the B3 series servo motor specifications.
		B	Add the contents of IP67 connector, B3 military connector, CN1 connector and quick connector for A3-F and A3-E models.

Release date	Version	Chapter	Revision contents
July, 2020	V5.0 (Fifth edition)	8.3	Modify the descriptions for the setting values of PM.022: setting value 2 is for NTC level thermistor; setting value 3 is for PTC level thermistor.
December, 2019	V4.0 (Fourth edition)	3.1.4	Correct the UVW connector pin assignments for F80 and below models.
August, 2019	V3.0 (Third edition)		The A3-L model supports the E-Cam function.
		1.2.2	Modify the descriptions for model codes and specifications.
		1.4	Add the name of each part for all models.
		2.4	Add Sections 2.4.1 - 2.4.6.
		2.7.1	Modify the model names of the EMI Filters.
		2.8	Modify the notes for the regenerative resistor.
		3.1.2	Modify the wiring description for the external brake unit.
		3.1.3	Modify the wiring diagram for power supply. Add the description for connecting multiple servo drives.
		3.1.4	Modify the connector wire colors.
		3.1.6	Modify the UVW cable diameter and encoder cable size.
		3.3.2	Modify the table contents and add the notes.
		3.3.5	Modify the C1 wiring diagram and C2 maximum output voltage.
		3.5	Add the descriptions for CN3 communication port.
		3.7	Add the descriptions for CN5 pin10 to pin14. Add the voltage specification. Modify the maximum single-phase frequency of the encoder.
		3.8.1	Modify the resistor value.
		3.10	Add the STO function descriptions.
		4.5.2	Modify the corrective actions for AL013. Modify the control circuit name.
4.5.3	Add the description for Step 5.		
5	Remove the Quick mode section.		
5.1.1	Modify the flowchart of the tuning procedure.		
5.1.2	Add "Note 2".		

Release date	Version	Chapter	Revision contents
August, 2019	V3.0 (Third edition)	5.2	Add the descriptions for gain related parameters.
		5.3.4	Add the description for Gain adjustment mode 3.
		5.3.5	Modify the bandwidth response level diagram.
		5.4	Modify the descriptions for tuning in manual mode.
		6.2.3	Modify the control structure diagram of Position mode.
		6.2.4	Modify the diagram of Position and S-curve speed and time setting (decremental position command).
		6.2.7	Modify the timing diagram of PR mode.
		6.2.9	Modify the diagram of the low-frequency vibration suppression.
		6.3.3	Modify the S-curve and time setting diagram.
		6.3.4	Modify the analog speed command diagram.
		6.3.5	Modify the timing diagram of Speed mode.
		6.3.7	Modify the suppression intensity of the notch filter.
		6.4.1	Modify the range of torque commands.
		6.4.5	Modify the timing diagram of Torque mode.
		6.5	Modify the timing diagrams of dual mode.
		6.6	Modify the timing diagrams when applying speed limit and torque limit.
		7.1.2	Modify Figure 7.1.2.3 and Figure 7.1.2.4.
		7.1.3	Modify the parameter tables relevant to the Homing mode. Modify Figure 7.1.3.1. Modify the diagram of referencing the torque limit.
		7.1.6	Modify Figure 7.1.6.4, Figure 7.1.6.6 (b), and Figure 7.1.6.14. Add the interpreting method of the PR path procedure.
		7.2.2	Modify the description of the Capture axis source setting table. Modify Figure 7.2.2.1 and Figure 7.2.2.2.
7.2.3	Modify the description of the Compare axis source setting table. Modify Figure 7.2.3.1, Figure 7.2.3.2, Figure 7.2.3.3, and Figure 7.2.3.4.		
7.3	Add the E-Cam section.		

Release date	Version	Chapter	Revision contents
August, 2019	V3.0 (Third edition)	8.2	Correct the contents for P0.002, P0.003, P1.044, and P1.045.
		8.3	<p>Modify the parameter descriptions for P0.002, P0.003, P0.051, P0.052, P0.053, P0.054, P0.055, P0.012, P1.000, P1.001, P1.004, P1.036, P1.037, P1.046, P1.047, P1.055, P1.056, P1.074, P1.076, P1.083, P1.087, P1.097, P2.010, P2.018, P2.026, P2.027, P2.032, P2.049, P2.066, P2.068, P2.077, P2.089, P2.093, P2.112, P4.019, P4.020, P4.021, P5.003, P5.037, P5.039, P5.057, P5.059, P5.097, P6.000, and P6.003.</p> <p>Add parameters P0.056, P0.057, P0.058, P0.059, P0.060, P0.061, P1.064, P1.065, P1.066, P1.111, P2.084, P2.088, and PM parameters.</p> <p>Add monitoring variables 85, 121, -80, -91, -124, -177, and -178.</p> <p>Modify monitoring variables 12, 29, 30, 31, 48, 68, and 69.</p> <p>Modify the DI descriptions for 0x06, 0x0D, 0x16, and 0x17.</p> <p>Modify the DO description for 0x18.</p> <p>Add DI 0x0E.</p> <p>Add DOs 0x1A, 0x2D, 0x2E, and 0x2F.</p>
		9.3	Modify the communication introduction and the 11-bit character frame.
		9.4	Add PM parameters.
		9.5	Add RS-485 communication specification.
		10.2.2	Modify the minimum battery voltage.
		10.3	Modify the description for system initialization.
		11	Add the Linear Motor chapter.
		12	Add the CANopen Mode chapter.
		13.1	<p>Modify the alarm description for AL503.</p> <p>Add alarms AL050, AL054, AL05B, AL05C, AL219, AL249, AL35F, AL3CF, AL3E2, and AL3E3.</p> <p>Delete alarms AL302 and AL303.</p>



Release date	Version	Chapter	Revision contents
August, 2019	V3.0 (Third edition)	13.2	<p>Modify the alarm descriptions for AL001, AL006, AL014, AL015, AL018, AL024, AL034, AL035, AL041, AL045, AL052, AL058, AL060, AL067, AL06A, AL07E, AL086, AL235, AL283, AL284, AL285, AL289, AL3F1, and AL503.</p> <p>Add alarms AL050, AL054, AL05B, AL05C, AL219, AL249, AL35F, AL3CF, AL3E2, and AL3E3.</p> <p>Delete alarms AL302 and AL303.</p>
		Appendix A	Modify the specifications of the ECM-A3 series motors.
		Appendix B	<p>Add the DMCNET terminal resistor.</p> <p>Add the power cable specification.</p> <p>Add the power cable size.</p> <p>Add the encoder connector.</p> <p>Add the encoder cable specification.</p> <p>Add the A2/A3 conversion cable part numbers.</p> <p>Add the USB cable and USB isolator part numbers.</p> <p>Modify the tables of the optional accessories.</p>
December, 2017	V2.0 (Second edition)	8.2	<p>Change the parameter default values of P1.000, P1.030, P2.031, and P2.047.</p> <p>Change the parameter format of P2.031.</p>
		3.1.4	Add notes for the UVW connector illustration (angle of viewing).
		3.9 & 3.10	Add notes for the STO connector: STO certification application in progress.
		9.1	Correct the pin numbers in the figure of RS-485 communication interface.
April, 2017	V1.0 (First edition)		

For relevant information about [ASDA-A3], please refer to:

- (1) ASDA-A2 User Manual