

## Industrial Automation Headquarters

### Taiwan: Delta Electronics, Inc.

Taoyuan Technology Center  
No.18, Xinglong Rd., Taoyuan District,  
Taoyuan City 33068, Taiwan  
TEL: +886-3-362-6301 / FAX: +886-3-371-6301

## Asia

### China: Delta Electronics (Shanghai) Co., Ltd.

No.182 Minyu Rd., Pudong Shanghai, P.R.C.  
Post code : 201209  
TEL: +86-21-6872-3988 / FAX: +86-21-6872-3996  
Customer Service: 400-820-9595

### Japan: Delta Electronics (Japan), Inc.

Industrial Automation Sales Department  
2-1-14 Shibadaimon, Minato-ku  
Tokyo, Japan 105-0012  
TEL: +81-3-5733-1155 / FAX: +81-3-5733-1255

### Korea: Delta Electronics (Korea), Inc.

1511, 219, Gasan Digital 1-Ro., Geumcheon-gu,  
Seoul, 08501 South Korea  
TEL: +82-2-515-5305 / FAX: +82-2-515-5302

### Singapore: Delta Energy Systems (Singapore) Pte Ltd.

4 Kaki Bukit Avenue 1, #05-04, Singapore 417939  
TEL: +65-6747-5155 / FAX: +65-6744-9228

### India: Delta Electronics (India) Pvt. Ltd.

Plot No.43, Sector 35, HSIIDC Gurgaon,  
PIN 122001, Haryana, India  
TEL: +91-124-4874900 / FAX: +91-124-4874945

### Thailand: Delta Electronics (Thailand) PCL.

909 Soi 9, Moo 4, Bangpoo Industrial Estate (E.P.Z),  
Pattana 1 Rd., T.Phraksa, A.Muang,  
Samutprakarn 10280, Thailand  
TEL: +66-2709-2800 / FAX: +66-2709-2827

### Australia: Delta Electronics (Australia) Pty Ltd.

Unit 20-21/45 Normanby Rd., Notting Hill Vic 3168, Australia  
TEL: +61-3-9543-3720

## Americas

### USA: Delta Electronics (Americas) Ltd.

5101 Davis Drive, Research Triangle Park, NC 27709, U.S.A.  
TEL: +1-919-767-3813 / FAX: +1-919-767-3969

### Brazil: Delta Electronics Brazil

Rua Itapeva, 26 - 3º, andar Edifício Itapeva,  
One - Bela Vista 01332-000 - São Paulo - SP - Brazil  
TEL: +55-12-3932-2300 / FAX: +55-12-3932-237

### Mexico: Delta Electronics International Mexico S.A. de C.V.

Gustavo Baz No. 309 Edificio E PB 103  
Colonia La Loma, CP 54060  
Tlalneantla, Estado de México  
TEL: +52-55-3603-9200

## EMEA

### EMEA Headquarters: Delta Electronics (Netherlands) B.V.

Sales: Sales.IA.EMEA@deltaww.com  
Marketing: Marketing.IA.EMEA@deltaww.com  
Technical Support: iatechnicalsupport@deltaww.com  
Customer Support: Customer-Support@deltaww.com  
Service: Service.IA.emea@deltaww.com  
TEL: +31(0)40 800 3900

### BENELUX: Delta Electronics (Netherlands) B.V.

Automotive Campus 260, 5708 JZ Helmond, The Netherlands  
Mail: Sales.IA.Benelux@deltaww.com  
TEL: +31(0)40 800 3900

### DACH: Delta Electronics (Netherlands) B.V.

Coesterweg 45, D-59494 Soest, Germany  
Mail: Sales.IA.DACH@deltaww.com  
TEL: +49(0)2921 987 0

### France: Delta Electronics (France) S.A.

ZI du bois Challand 2, 15 rue des Pyrénées,  
Lisses, 91090 Evry Cedex, France  
Mail: Sales.IA.FR@deltaww.com  
TEL: +33(0)1 69 77 82 60

### Iberia: Delta Electronics Solutions (Spain) S.L.U

Ctra. De Villaverde a Vallecas, 265 1º Dcha Ed.  
Hormigueras – P.I. de Vallecas 28031 Madrid  
TEL: +34(0)91 223 74 20  
Carrer Llacuna 166, 08018 Barcelona, Spain  
Mail: Sales.IA.Iberia@deltaww.com

### Italy: Delta Electronics (Italy) S.r.l.

Via Meda 2–22060 Novedrate(CO)  
Piazza Grazioli 18 00186 Roma Italy  
Mail: Sales.IA.Italy@deltaww.com  
TEL: +39 039 8900365

### Russia: Delta Energy System LLC

Vereyskaya Plaza II, office 112 Vereyskaya str.  
17 121357 Moscow Russia  
Mail: Sales.IA.RU@deltaww.com  
TEL: +7 495 644 3240

### Turkey: Delta Greentech Elektronik San. Ltd. Sti. (Turkey)

Şerifali Mah. Hendem Cad. Kule Sok. No:16-A  
34775 Ümraniye – İstanbul  
Mail: Sales.IA.Turkey@deltaww.com  
TEL: + 90 216 499 9910

### MEA: Eltek Dubai (Eltek MEA DMCC)

OFFICE 2504, 25th Floor, Saba Tower 1,  
Jumeirah Lakes Towers, Dubai, UAE  
Mail: Sales.IA.MEA@deltaww.com  
TEL: +971(0)4 2690148

Delta CNC Milling Machine Solution Operation and Maintenance Manual



# Delta CNC Milling Machine Solution Operation and Maintenance Manual

# Preface

---

Thank you for using this product. Please read this manual carefully before use to ensure proper usage, and keep this manual at an obvious location to read at any time.

This manual includes:

- Installation and inspection of NC controllers
- Wiring for connectors of the NC controllers
- Description of the function and operation of NC controllers
- Description of parameters
- Troubleshooting

NC controller product features:

- Built-in 32-bit high-speed dual CPU for multi-task execution, improving operating performance
- User-friendly human machine interface
- Interfaces for auto tuning and gain adjustment of the servo, meeting different machine characteristics
- CNCSoft-B software for configuring user-defined screens
- Front USB interface (port) for easy data access, data backup, and parameter file copying
- In Spindle mode, you can control the spindle system with DMCNET communication or analog voltage according to the requirements
- Serial I/O modules for flexible I/O configuration

How to use this manual:

Use this manual as a reference when installing, setting up, operating, and maintaining the NC controller. Read this manual before using and setting this product.

Delta technical services:

Consult your equipment distributors or Delta Customer Service Center if you encounter any problem.

## Safety Precautions

- Refer to the pin assignment when wiring. Ensure the product is properly grounded.
- Do not disassemble the controller, change the wiring, or touch the power supply when the power is on to avoid electric shock.

Pay special attention to the following safety precautions at all times during installation, wiring, operation, maintenance, and examination of the controller.

The symbols of “DANGER”, “WARNING” and “STOP” indicate:



**Danger. May cause severe or fatal injuries to personnel if the instructions are not followed.**



**Warning. May cause moderate injury to personnel, or lead to severe damage or even malfunction of the product if the instructions are not followed.**



**Absolute prohibited activities. May cause serious damage or even malfunction of the product if the instructions are not followed.**

### Precautions for installation



- Follow the installation instructions in the manual, or it may result in damage to the equipment.
- Do not expose the product to an environment containing vapor, corrosive gas, inflammable gas, or other foreign matter to reduce the risk of electric shock or fire.

### Precautions for wiring



- Connect the ground terminal to class-3 (below 100  $\Omega$ ) ground system. Improper grounding may result in electric shock or fire.

### Precautions for operation



- Correctly plan the I/O configuration with the MLC editor software, or abnormal operation may occur.
- Before operating the machine, properly adjust the parameter settings, otherwise it may cause abnormal operation or malfunction.
- Ensure you can activate the emergency stop at any time, and avoid operating the machine in unprotected condition.



- Do not change the wiring when the power is on, or it may lead to personal injury caused by electric shock.
- Do not use a sharp-pointed object to touch the panel. Doing this may dent the screen and lead to malfunction of the controller.

## Maintenance and Inspection



- When the power is on, do not disassemble the controller panel or touch the internal parts of the controller, or it may cause electric shock.
- Do not touch the wiring terminal within 10 minutes after turning off the power since the residual voltage may cause electric shock.
- Turn off the power before replacing the battery, and check the system settings after the replacement.

## Wiring method



- Power supply: use a 24 V<sub>DC</sub> power supply for the controller and comply with the wire specification when wiring to avoid danger.
- Wire selection: Use stranded wires and multi-core shielded-pair wires for signal cables.
- Cable length: the maximum cable length of the signal cable for remote I/O and DMCNET communication is 20 m and the maximum cable length of other signal cables is 10 m.
- The local I/O and remote I/O require an additional 24 V<sub>DC</sub> power for signal input and output.

## Wiring of Communication Circuit



- DMCNET wiring: the wiring materials should comply with the standard specification.
- Make sure the controller and servo drive are firmly connected, or loose cables may cause abnormal operation.

Note: The content of this manual may be revised without prior notice. Download the latest version from Delta's website at <https://www.deltaww.com/>.



(This page is intentionally left blank.)

# Table of Content

---

## Before use

### 1

#### Product Inspection and Model Explanation

1.1	Product inspection .....	1-2
1.2	A series product model explanation .....	1-3
1.3	Product interface A series NC controller.....	1-4
1.4	B series product model explanation .....	1-11
1.5	Product interface A series NC controller.....	1-12

### 2

#### Installation

2.1	A series product installation explanation .....	2-2
2.1.1	Ambient storage conditions.....	2-2
2.1.2	Ambient installation conditions .....	2-2
2.1.3	Mounting direction and space.....	2-3
2.1.4	Hardware specifications .....	2-4
2.1.5	Outline and mounting dimensions .....	2-6
2.1.6	Operating interface installation (for OPENCNC models).....	2-8
2.2	B series product installation explanation .....	2-10
2.2.1	Ambient storage conditions.....	2-10
2.2.2	Ambient installation conditions .....	2-10
2.2.3	Mounting direction and space.....	2-11
2.2.4	Hardware specifications .....	2-12
2.2.5	Outline and mounting dimensions .....	2-13
2.2.6	Operating interface installation (for OPENCNC models).....	2-16

### 3

#### Wiring

3.1	A series product .....	3-3
3.1.1	A series system interface .....	3-3
3.1.2	A series controller connectors .....	3-10
3.1.2.1	NC3 series connectors .....	3-10
3.1.2.2	NC2 series connectors .....	3-13
3.1.2.3	OPENCNC series connectors .....	3-16
3.1.3	Wiring for power connector .....	3-18
3.1.4	Wiring for RS-485 connector .....	3-19
3.1.5	Wiring for Axis 1 - 4 input connector .....	3-21
3.1.6	Wiring for spindle feedback input connector .....	3-24

3.1.7	Wiring for spindle analog output connector.....	3-26
3.1.8	Wiring for HSI connector .....	3-29
3.1.9	Wiring for emergency stop.....	3-32
3.1.10	Wiring for MPG connector.....	3-34
3.1.11	Wiring for remote I/O connector .....	3-39
3.1.11.1	NC-EIO-R2010.....	3-43
3.1.11.2	NC-EIO-R3216.....	3-46
3.1.11.3	NC-EIO-R3232.....	3-49
3.1.11.4	NC-EIO-T3232 .....	3-52
3.1.12	Wiring for local I/O connector .....	3-55
3.1.13	Wiring for I/O connector on machine operation panel B of NC300 / NC310 series models.....	3-57
3.1.14	Wiring for I/O connector on machine operation panel B of NC311 series models..	3-60
3.2	B series product.....	3-63
3.2.1	B series system interface .....	3-63
3.2.2	B series controller connectors .....	3-73
3.2.2.1	NC3□□B series connectors .....	3-73
3.2.2.2	NC200B series connectors .....	3-76
3.2.2.3	OPENCNC series connectors .....	3-78
3.2.3	Wiring for power connector.....	3-80
3.2.4	Wiring for spindle pulse output connector .....	3-81
3.2.5	Wiring for RS-485 connector.....	3-84
3.2.6	Wiring for spindle analog feedback connector.....	3-86
3.2.7	Wiring for spindle analog output connector.....	3-88
3.2.8	Wiring for HSI connector .....	3-91
3.2.9	Wiring for emergency stop.....	3-93
3.2.10	Wiring for MPG connector.....	3-94
3.2.11	Wiring for remote I/O connector .....	3-98
3.2.11.1	NC-EIO-R2010.....	3-102
3.2.11.2	NC-EIO-R3216.....	3-105
3.2.11.3	NC-EIO-R3232.....	3-108
3.2.11.4	NC-EIO-T3232 .....	3-111
3.2.12	Wiring for local I/O connector .....	3-114
3.2.13	Wiring for I/O connector on machine operation panel B of NC3□□ series models.....	3-119

## How to operate and set

# 4

### Table of Group Function

4.1	System group function table.....	4-2
4.2	Machine operation panel A - function of keys .....	4-11
4.3	Machine operation panel B - function of keys.....	4-13
4.4	Table of corresponding buttons (for OPEN CNC models) .....	4-15

# 5

### Introduction to NC System Modes

5.1	Auto mode (AUTO).....	5-2
5.2	Program edit mode (EDIT).....	5-2
5.3	Manual input mode (MDI).....	5-2
5.4	MPG mode (MPG).....	5-2
5.5	Jog mode (JOG) .....	5-3
5.6	Rapid mode (RAPID).....	5-3
5.7	Homing mode (HOME) .....	5-3
5.8	Group screen overview.....	5-4

# 6

### Position (POS) Group

6.1	Absolute coordinates.....	6-3
6.2	Relative coordinates.....	6-3
6.3	Machine coordinates .....	6-3

# 7

### Program (PRG) Group

7.1	Ethernet setting.....	7-3
7.2	Create a new file (NEW F).....	7-8
7.3	Copy files (COPY F).....	7-9
7.4	Paste files (PASTE) .....	7-9
7.5	Delete files and directories (DEL).....	7-9
7.6	Select / cancel selection of multiple files (ALL SEL TOGL / CANCEL) .....	7-10
7.7	Rename files (RENAME).....	7-12
7.8	Create directories (FOLDER) .....	7-13
7.9	Search for files (FIND F) .....	7-14
7.10	File merging (MERGE).....	7-14
7.11	Sequencing (SORT) .....	7-15
7.12	Convert DXF files (Transform) .....	7-16
7.13	Macro files (MACRO).....	7-17
7.14	Save macros in the bottom layer (INT MRO).....	7-17

7.15	File editing (File edit)	7-17
7.15.1	Line search (LABEL)	7-19
7.15.2	String search (STRING)	7-19
7.15.3	Edit a section of program (B START / B END)	7-21
7.15.4	Delete lines and sections (DEL)	7-22
7.15.5	Copy lines and sections and paste (COPY and PASTE)	7-22
7.15.6	Undo (UNDO)	7-22
7.16	Program function in other modes	7-23

## 8

### Offset (OFS) Group

8.1	Coordinate setting (COORD)	8-2
8.1.1	Auto set (AUTO)	8-3
8.1.2	Absolute input (ABS)	8-7
8.1.3	Incremental input (INC)	8-9
8.1.4	Center of rectangle (SQUARE)	8-10
8.1.5	Center of circle (CIRCLE)	8-12
8.2	Tool setting (CUTTER)	8-14
8.2.1	Milling machine system	8-14
8.3	Tool magazine management (MAGA)	8-17
8.3.1	Multi-magazine management	8-22
8.4	Macro variables (MACRO)	8-23
8.4.1	Local variables (LOCAL)	8-23
8.4.2	Global variables (GLOBAL)	8-24
8.4.3	Non-volatile variables (HOLD)	8-24
8.4.4	Extension variables (EXTEND)	8-24

## 9

### Diagnosis (DGN) Group

9.1	Machining information (PROCESS)	9-2
9.2	User variable (USR VAR)	9-4
9.3	MLC	9-5
9.3.1	Bit (BIT)	9-5
9.3.2	Register (REG)	9-7
9.3.3	Device monitoring (DEV MON)	9-8
9.3.4	Line search (JUMP TO)	9-10
9.3.5	Editor (EDITOR)	9-10
9.3.6	Operation (SET)	9-13
9.4	System monitoring (SYS MON)	9-14
9.4.1	Servo monitoring (SRV MON)	9-14
9.4.2	I/O monitoring (I/O MON)	9-14

9.4.3	Variable monitoring (VAR MON).....	9-15
9.5	Password setting (PWD).....	9-17
9.5.1	System security (S SCP).....	9-17
9.5.2	Machine security (M SCP).....	9-18
9.5.3	User security (User SCP).....	9-21
9.5.4	Expiration time (EXPIRE).....	9-22
9.6	System information (STATUS).....	9-25
9.7	Gain tuning (TUNING).....	9-26
9.8	Import (IMPORT).....	9-29
9.9	Export (EXPORT).....	9-31
9.10	Multi-language (TEXT WR).....	9-33
9.11	LOGO (LOGO WR).....	9-33

# 10

## Alarm (ALM) Group

10.1	Alarm (ALARM).....	10-2
10.2	Alarm history (HISTORY).....	10-3

# 11

## Graph (GRA) Group

11.1	Trajectory display.....	11-3
11.2	Program simulation.....	11-4

## Parameter Settings

# 12

## Parameter (PAR) Group

12.1	Machining parameter (PROCESS).....	12-4
12.1.1	Machining parameter descriptions.....	12-4
12.2	Operating parameter (OPERATE).....	12-7
12.2.1	Operating parameter descriptions.....	12-7
12.3	Tool magazine parameter (MAGA).....	12-22
12.3.1	Tool magazine parameter descriptions.....	12-22
12.4	Spindle parameter (SPINDLE).....	12-24
12.4.1	Spindle parameter descriptions.....	12-24
12.5	Machine parameter (MACHINE).....	12-30
12.5.1	Machine parameter descriptions.....	12-30
12.6	Homing parameter (HOME).....	12-32
12.6.1	Homing parameter descriptions.....	12-32
12.7	Ethernet setting (ETH.).....	12-38
12.7.1	Ethernet parameter descriptions.....	12-38



12.8 Compensation parameter (COMP).....	12-40
12.8.1 Compensation parameter descriptions .....	12-41
12.9 System parameter (SYSTEM) .....	12-44
12.9.1 System parameter descriptions.....	12-44
12.10 MLC setting (MLC) .....	12-52
12.10.1 MLC parameter descriptions.....	12-52
12.11 Graph parameter (GRAPHIC) .....	12-56
12.11.1 Graph parameter descriptions .....	12-56
12.12 Servo parameter (SERVO).....	12-58
12.12.1 Servo parameter descriptions .....	12-58
12.13 Channel setting (CONFIG) .....	12-61
12.14 RIO setting .....	12-62
12.14.1 Details of RIO setting .....	12-63
12.14.2 Setting DA module (NC-EIO-DAC04).....	12-65
12.15 Search (SEARCH).....	12-66
12.16 Parameter group (PARAM GRP) .....	12-66
12.17 Other settings.....	12-68
12.17.1 Setting for absolute motor .....	12-68
12.17.2 Setting synchronous motion control.....	12-70
12.17.3 Command transfer .....	12-73

## Customization function

# 13

## Software (SOFT) Group

13.1 ScreenEditor software.....	13-2
---------------------------------	------

## How to check controlled devices

# 14

## MLC Special M Relay and Special D Register

14.1 MLC special M and D definitions .....	14-2
14.2 Special M summary table .....	14-3
14.3 Special D summary table.....	14-27

# 15

## Troubleshooting

15.1	Alarm description .....	15-2
15.2	MLC errors (1200 - 13FF) .....	15-3
15.3	Servo errors (1E00) .....	15-5
15.4	Remote I/O error (1F00) .....	15-5
15.5	HMI related alarms (3010 - 3FFF) .....	15-6
15.6	NC system errors (4200 - 4FFF) .....	15-8
15.7	NC channel errors (B000 - EFFF) .....	15-10
15.7.1	Machining related alarms (B000 - B0FF) .....	15-10
15.7.2	Tool compensation related alarms (B100 - B1FF) .....	15-12
15.7.3	Milling machine related alarms (B300 - B3FF) .....	15-13
15.7.4	Command related alarms (B600 - B6FF; B64x not included) .....	15-14
15.7.5	Temperature compensation related alarms (B640 - B64F) .....	15-16
15.7.6	Lathe cycle command alarms (B6A1 - B6A5) .....	15-16

(This page is intentionally left blank.)

# Product Inspection and Model Explanation

---

# 1

This chapter provides explanations for the A and B series product models, and the introductions to the product interface of the NC controllers.

1.1	Product inspection .....	1-2
1.2	A series product model explanation .....	1-3
1.3	Product interface A series NC controller .....	1-4
1.4	B series product model explanation .....	1-11
1.5	Product interface A series NC controller .....	1-12

## 1.1 Product inspection

In case of packaging mistakes or damages during shipping, check the items listed in the following table carefully. If any issue occurs, contact the distributor for service.

Item	Content
Purchased product	Check the model number on the nameplate of the controller. Refer to Sections 1.2 and 1.4 for the model explanation.
Buttons	Press the buttons to check if the operation is smooth*.
Appearance	Visually check if there are any damages on the exterior of the product.
Connectors	Check if there are any loose or untightened connectors.

Note: this is applicable to all models except for the OPENCNC models.

## 1.2 A series product model explanation

■ Nameplate information

Model name --- MODEL : NC300A-MI-A

Input power --- INPUT : DC +24V Class 2 / 600 mA

Barcode and serial number --- 300AMIA6T16010001

Designed by DELTA Taiwan  
No.18, Xinglong Rd., Taoyuan City 33068, Taiwan

MADE IN TAIWAN

■ Model explanation

NC series controller (MOP integrated)

NC3 0 0 A - M I - A E  
 (1) (2)(3)(4) (5)(6) (7)(8)

No.	Item	Description
(1)	Series name	NC2: 2 series controller NC3: 3 series controller
(2)	Display	0: 8" screen 1: 10" screen
(3)	Screen orientation	0: horizontal 1: vertical
(4)	Series type	A: A series AH: multi-axis A series
(5)	Model	M: milling L: lathe
(6)	Type	I: integrated (machine operation panels integrated) P: separated type (machine operation panels not included) S: separated type (machine operation panel A included)
(7)	Version	A: standard
(8)	Language	Blank: Traditional Chinese S: Simplified Chinese E: English

OPENCNC series controller

NC30 E  
 (1) (2)

No.	Item	Description
(1)	Series name	NC30: 3 series controller
(2)	Series type	E: embedded A series EH: embedded multi-axis A series



### 1.3 Product interface of A series NC controller

NC300A(H)-MI-A

1

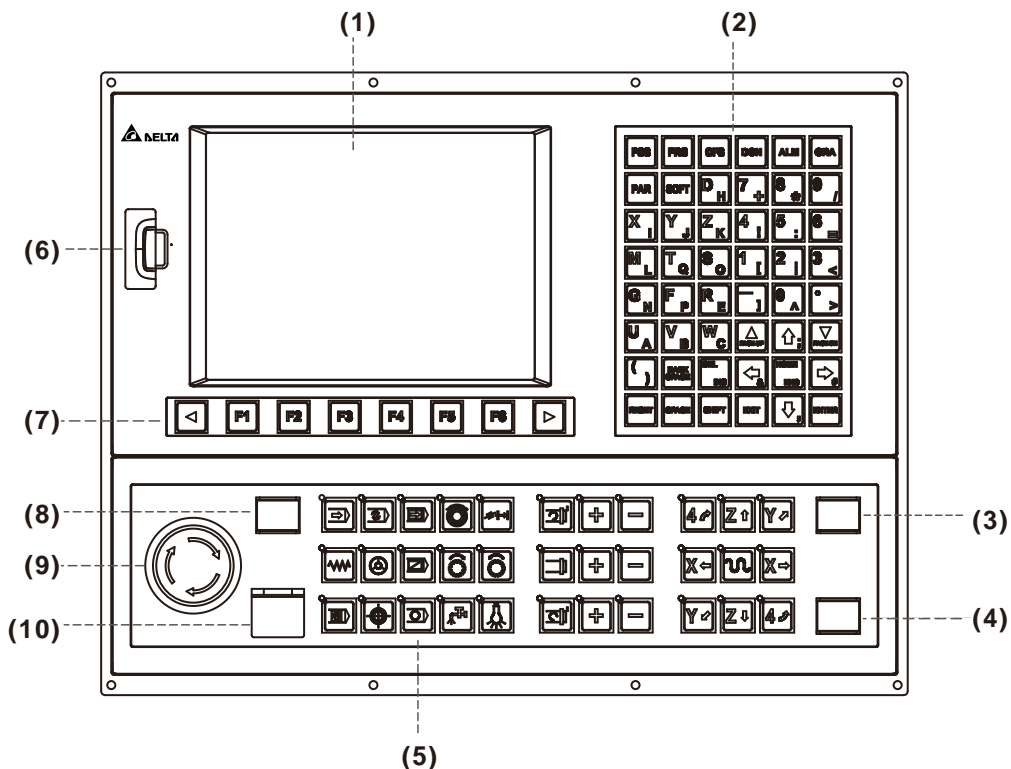

No.	Item	No.	Item
(1)	Screen	(6)	USB port
(2)	Machine operation panel A	(7)	Function keys
(3)	CYCLE START	(8)	Power On
(4)	FEED HOLD	(9)	Emergency stop
(5)	Machine operation panel B	(10)	Power Off

NC300A-MS-A\_

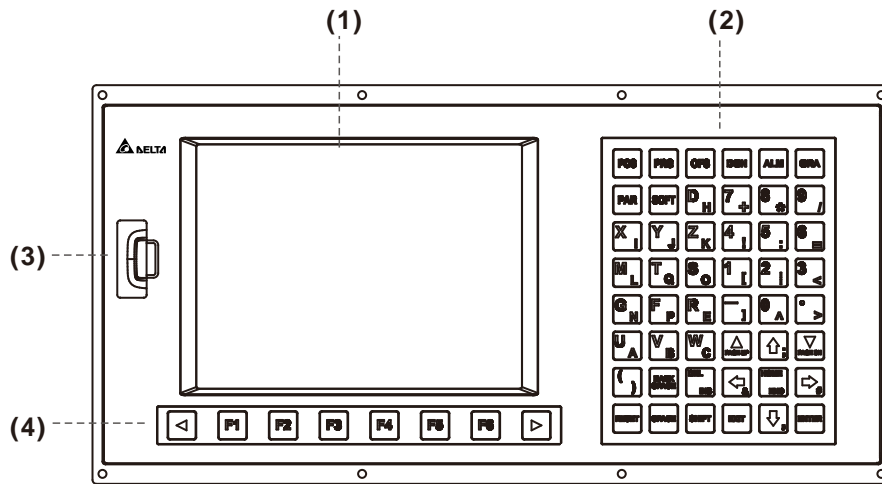

No.	Item
(1)	Screen
(2)	Machine operation panel A
(3)	USB port
(4)	Function keys

NC301A-MS-A\_

1

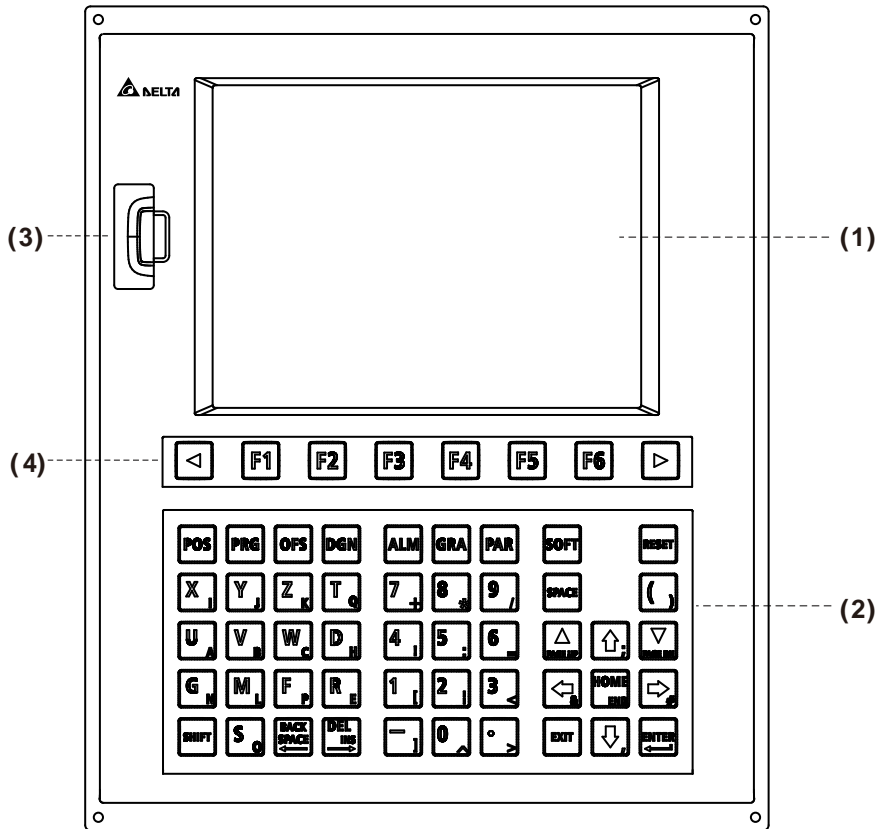

No.	Item
(1)	Screen
(2)	Machine operation panel A
(3)	USB port
(4)	Function keys

NC311A-MS-A\_

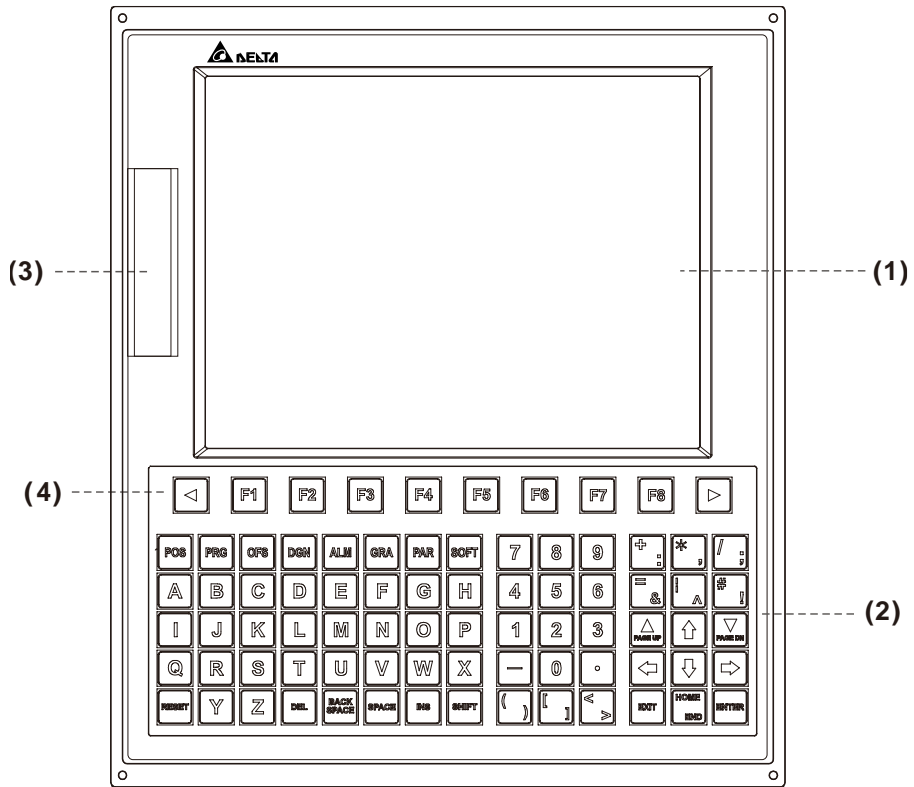

1

No.	Item
(1)	Screen
(2)	Machine operation panel A
(3)	USB port
(4)	Function keys

NC310A-MS-A\_

1

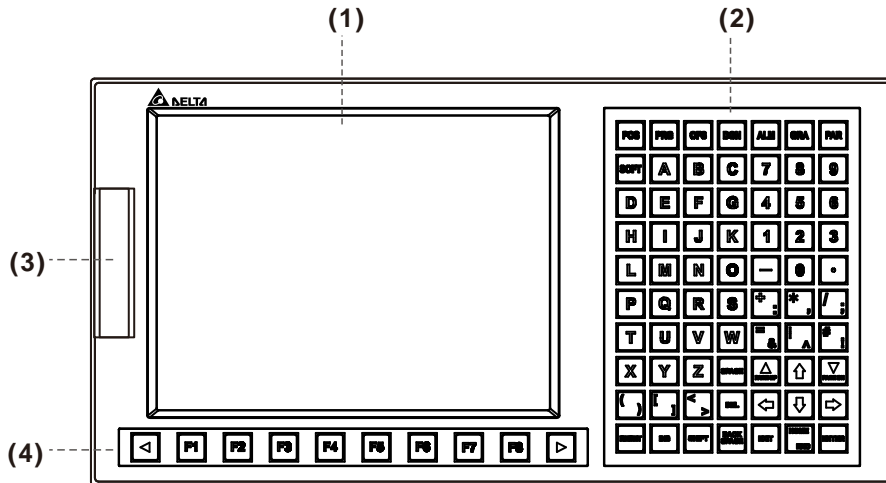

No.	Item
(1)	Screen
(2)	Machine operation panel A
(3)	USB port
(4)	Function keys

NC200A-MI-A

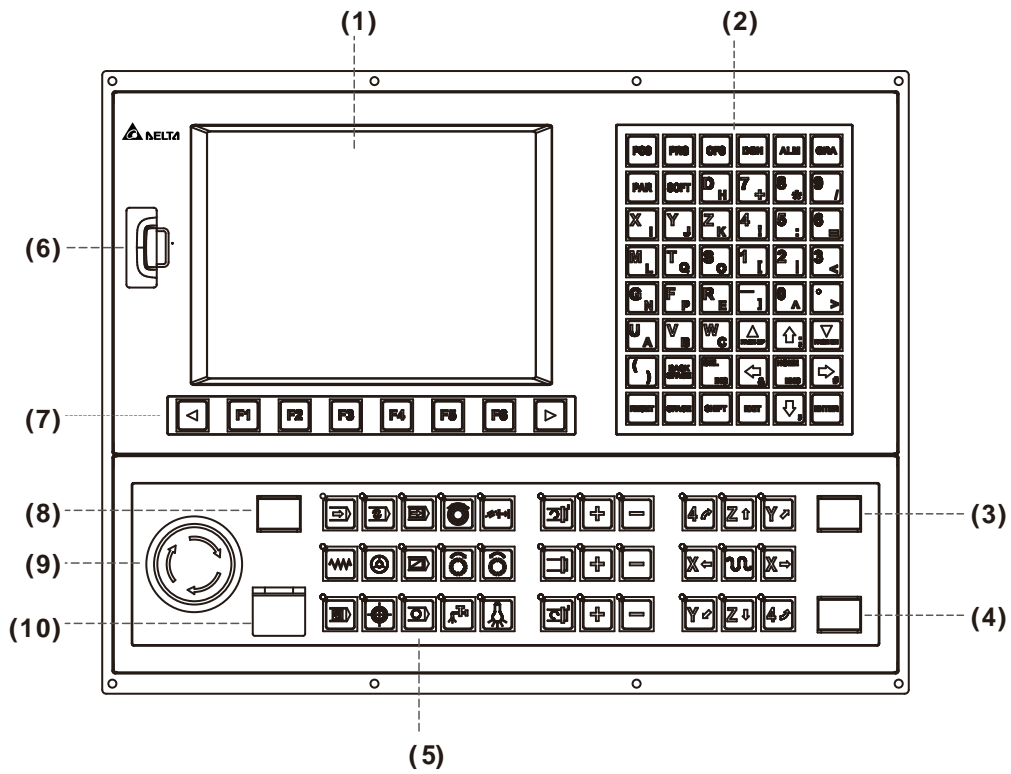

No.	Item	No.	Item
(1)	Screen	(6)	USB port
(2)	Machine operation panel A	(7)	Function keys
(3)	CYCLE START	(8)	Power On
(4)	FEED HOLD	(9)	Emergency stop
(5)	Machine operation panel B	(10)	Power Off

1



NC30E(H)

1

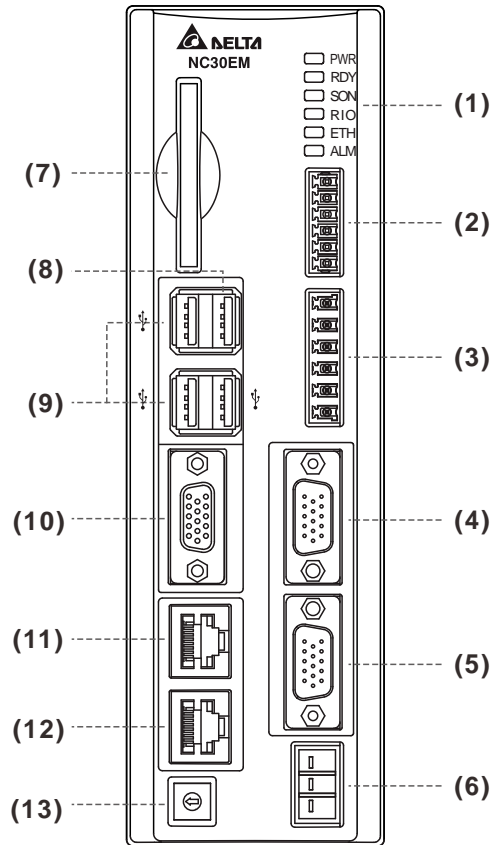

No.	Item	No.	Item
(1)	Indicators	(8)	Reserved
(2)	High-speed serial I/O terminal	(9)	USB port (Used to connect mouse, keyboard, or flash drive)
(3)	High-speed G31 terminal	(10)	VGA (Used to connect the screen)
(4)	MPG connector	(11)	Ethernet terminal
(5)	Spindle terminal	(12)	DMCNET terminal
(6)	24 V <sub>DC</sub> controller power	(13)	Engineering knob
(7)	CF slot	-	-

### 1.4 B series product model explanation

■ Nameplate information

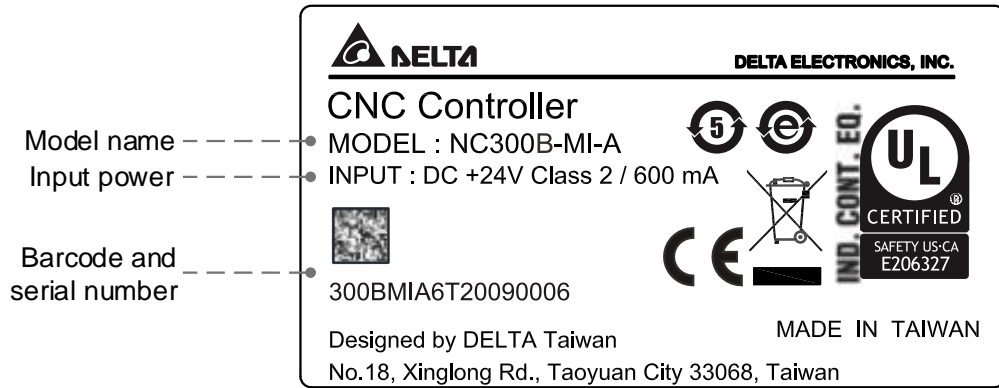

■ Model explanation

NC series controller (MOP integrated)

**NC3 0 0 B – M I – A E**  
 (1) (2) (3) (4) (5) (6) (7) (8)

No.	Item	Description
(1)	Series name	NC2: 2 series controller NC3: 3 series controller
(2)	Display	0: 8" screen 1: 10" screen
(3)	Screen orientation	0: horizontal 1: vertical
(4)	Series type	B: B series BH: multi-axis B series
(5)	Model	M: milling L: lathe
(6)	Type	I: integrated (machine operation panels integrated) P: separated type (machine operation panels not included) S: separated type (machine operation panel A included)
(7)	Version	A: standard
(8)	Language	Blank: Traditional Chinese S: Simplified Chinese E: English

OPENCNC series controller

**NC30 EB**  
 (1) (2)

No.	Item	Description
(1)	Series name	NC30: 3 series controller
(2)	Series type	EB: embedded B series EBH: embedded multi-axis B series

1

### 1.5 Product interface of B series NC controller

NC300B(H)-MI-A

1

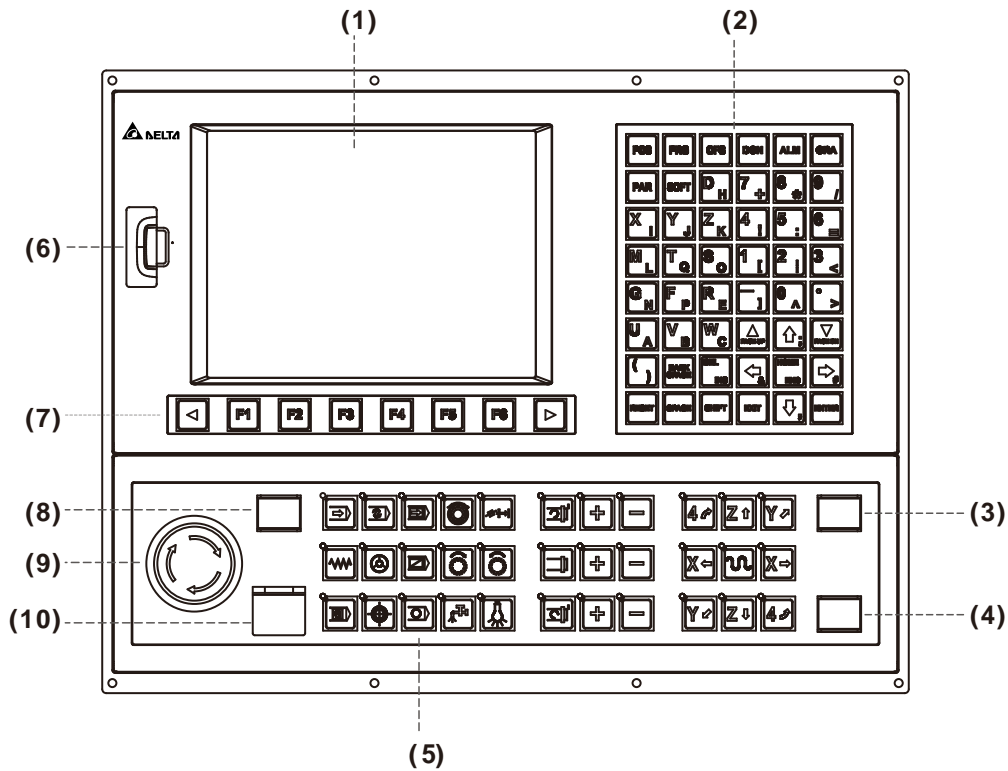

No.	Item	No.	Item
(1)	Screen	(6)	USB port
(2)	Machine operation panel A	(7)	Function keys
(3)	CYCLE START	(8)	Power On
(4)	FEED HOLD	(9)	Emergency stop
(5)	Machine operation panel B	(10)	Power Off

NC300B-MS-A

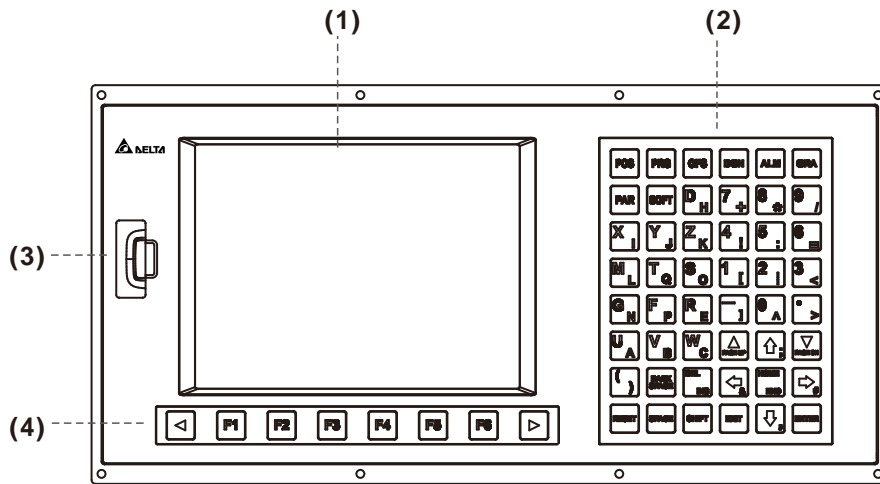

No.	Item
(1)	Screen
(2)	Machine operation panel A
(3)	USB port
(4)	Function keys

1

NC301B-MS-A\_

1

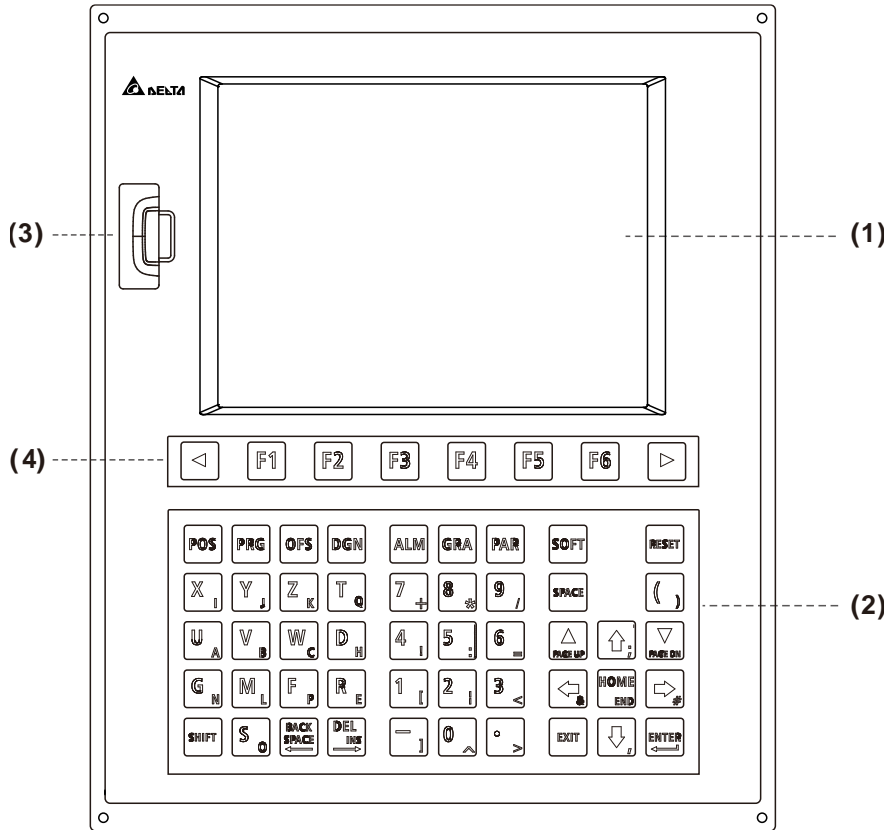

No.	Item
(1)	Screen
(2)	Machine operation panel A
(3)	USB port
(4)	Function keys

NC311B-MS-A\_

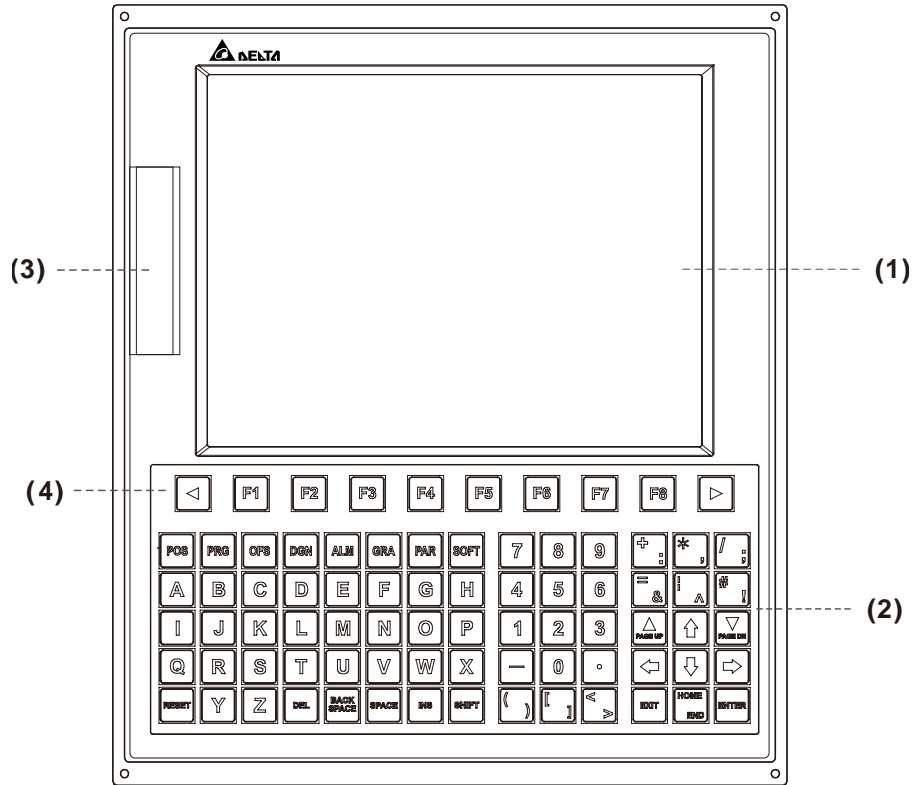

No.	Item
(1)	Screen
(2)	Machine operation panel A
(3)	USB port
(4)	Function keys



NC310B-MS-A\_

1

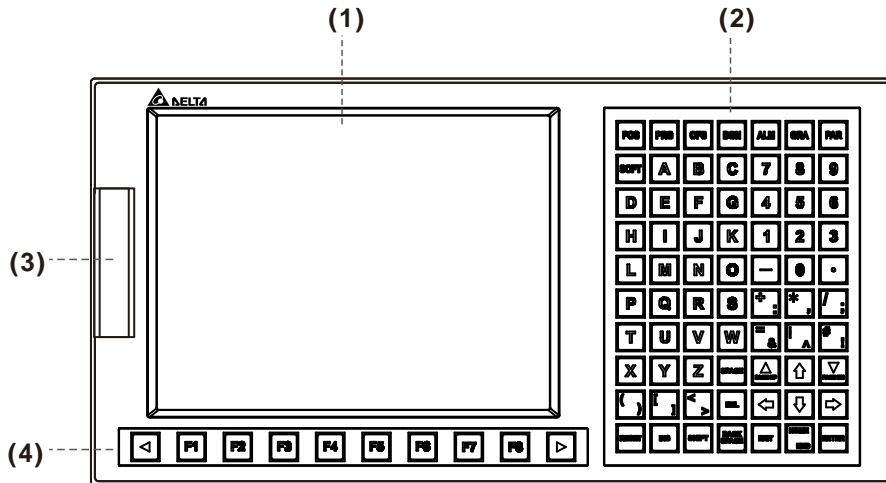

No.	Item
(1)	Screen
(2)	Machine operation panel A
(3)	USB port
(4)	Function keys

NC200B-MI-A

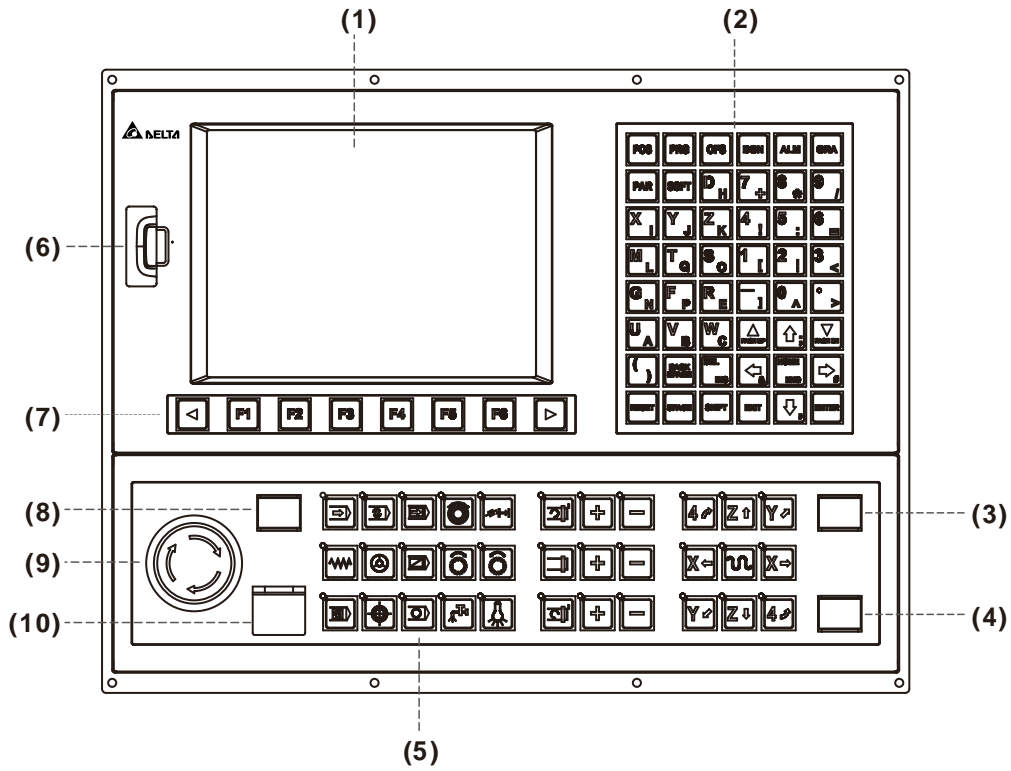

No.	Item	No.	Item
(1)	Screen	(6)	USB port
(2)	Machine operation panel A	(7)	Function keys
(3)	CYCLE START	(8)	Power On
(4)	FEED HOLD	(9)	Emergency stop
(5)	Machine operation panel B	(10)	Power Off

1

NC30EB(H)

1

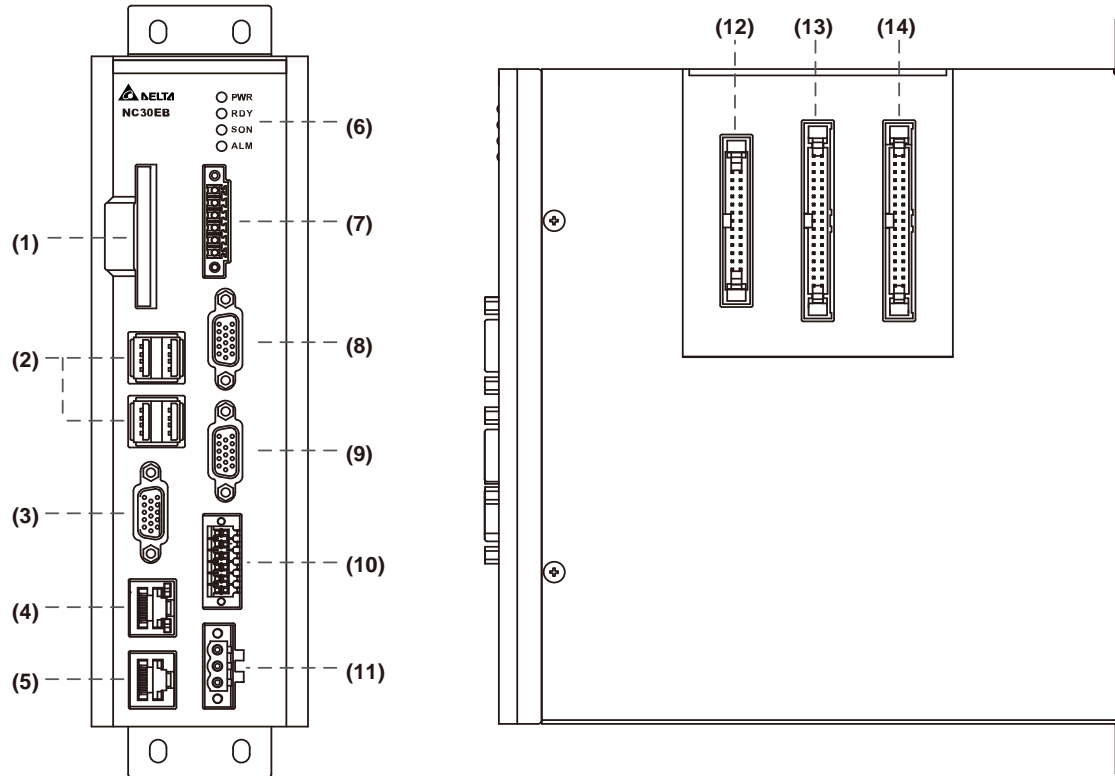

No.	Item	No.	Item
(1)	CF slot	(8)	MPG connector
(2)	USB port (Used to connect mouse, keyboard, or flash drive)	(9)	Spindle terminal
(3)	VGA (Used to connect the screen)	(10)	CN1 terminal
(4)	Ethernet terminal	(11)	24 V <sub>DC</sub> controller power
(5)	DMCNET terminal	(12)	Keypad I/O terminal
(6)	Indicators	(13)	I/O 1 terminal
(7)	Remote I/O terminal	(14)	I/O 2 terminal

# Installation

# 2

This chapter provides descriptions of the outline dimensions and hardware specifications of the product. Before installing the product, refer to the items detailed in this chapter, such as voltage, current, temperature, or other conditions. Otherwise, it may result in personal injuries or equipment damages.

---

2.1	A series product installation explanation .....	2-2
2.1.1	Ambient storage conditions .....	2-2
2.1.2	Ambient installation conditions .....	2-2
2.1.3	Mounting direction and space .....	2-3
2.1.4	Hardware specifications.....	2-4
2.1.5	Outline and mounting dimensions .....	2-6
2.1.6	Operating interface installation (for OPENCNC models).....	2-8
2.2	B series product installation explanation .....	2-10
2.2.1	Ambient storage conditions .....	2-10
2.2.2	Ambient installation conditions .....	2-10
2.2.3	Mounting direction and space .....	2-11
2.2.4	Hardware specifications.....	2-12
2.2.5	Outline and mounting dimensions .....	2-13
2.2.6	Operating interface installation (for OPENCNC models).....	2-16

## 2

## 2.1 A series product installation explanation

### 2.1.1 Ambient storage conditions

This product must be kept in the shipping carton before installation. To retain the warranty coverage and ensure future maintenance, follow these instructions for storage. While the product is temporarily not in use:

- Store the product in a dust-free and dry location.
- Store the product in an ambient temperature range of -20°C to +60°C (-4°F to +140°F).
- Store the product in a relative humidity range of 10% to 95% RH (non-condensing).
- Avoid storing the product in an environment containing corrosive gas and liquids.
- The environment should be free of devices that generate excessive heat; no water, vapor, dust, and oily dust; no corrosive and inflammable gas or liquids; no airborne dust or metal particles; the environment should be solid without vibration and interference of electromagnetic noise.

### 2.1.2 Ambient installation conditions

Operating temperature for the NC series controller: 0°C - 55°C (32°F - 131°F). During long-term operation, the suggested temperature of the operating environment should be below 45°C (113°F). If the temperature is above 45°C, place the product in a distribution board which is well-ventilated and without overheating risks. Also check if the vibration of the machine affects the electrical devices in the distribution board.

In addition, follow these precautions when choosing the installation site to retain the warranty coverage and ensure future maintenance for the Delta NC controller.

- The environment should be free of devices that generate excessive heat; no water, vapor, dust, and oily dust; no corrosive and inflammable gas or liquids; no airborne dust or metal particles; the environment should be solid without vibration and interference of electromagnetic noise.
- The temperature and humidity of the installation site for the NC controller should be within the range specified in the specification.
- The vibration at the location where you store the NC controller must not exceed the range specified in the specification.

### 2.1.3 Mounting direction and space

**Important:**

- The NC controller must be installed vertically on a dry and solid platform which complies with the requirement of NEMA.
- For better ventilation and cooling, allow sufficient clearance space between the NC controller and the adjacent objects and the wall (the clearance is suggested to be 50 mm (around 2 inches)), or it may cause malfunction of the machine.
- Do not block the ventilation holes of the NC controller, or it may cause malfunction of the machine.

## 2

## 2.1.4 Hardware specifications

## NC300A series milling machine controller

Model	NC300A-MI-A□	NC300A-MS-A□	NC301A-MS-A□	NC311A-MS-A□	NC310A-MS-A□
Operating environment	10% to 95% RH [0°C to +55°C (32°F to 131°F)]				
Storage environment	10% to 95% RH [-20°C to +60°C (-4°F to +140°F)]				
Cooling method	Natural cooling				
Voltage	DC +24V (-10% to +15%) (built-in isolated circuit)				
Dielectric withstanding voltage	Between 24 V <sub>DC</sub> and FG terminals: AC500V for 1 minute				
Power consumption	15 W (24V; 0.6 A)				
Battery	3V lithium battery (CR2032) × 1 Varies according to the ambient temperature and operating conditions; approximately 3 years in room temperature of 25°C (77°F)				
Dimensions W x H x D (mm)	400 x 309 x 123	400 x 200 x 97	260 x 260 x 313	290 x 335 x 95	435 x 221 x 95
Weight (kg)	4.1	3.1	3.3	3.8	3.8

## NC200 A series milling machine controller

Model	NC200A-MI-A□
Operating environment	10% to 95% RH [0°C to +55°C (32°F to 131°F)]
Storage environment	10% - 95% RH [-20°C to +60°C (-4°F to +140°F)]
Cooling method	Natural cooling
Voltage	DC +24V (-10% to +15%) (built-in isolated circuit)
Dielectric withstanding voltage	Between 24 V <sub>DC</sub> and FG terminals: AC500V for 1 minute
Power consumption	15 W (24V; 0.6 A)
Battery	3V lithium battery (CR2032) × 1 Varies according to the ambient temperature and operating conditions; approximately 3 years in room temperature of 25°C (77°F)
Dimensions W x H x D (mm)	400 x 320 x 91
Weight (kg)	4.5

## A series OPENCNC controller

Model	NC30E(H)
Operating environment	10% to 95% RH [0°C to +55°C (32°F to 131°F)]
Storage environment	10% to 95% RH [-20°C to +60°C (-4°F to +140°F)]
Cooling method	Natural cooling
Voltage	DC +24V (-10% to +15%) (built-in isolated circuit)
Dielectric withstanding voltage	Between 24 V <sub>DC</sub> and FG terminals: AC500V for 1 minute
Power consumption	15 W (24V; 0.6 A)
Battery	3V lithium battery (CR2032) × 1 Varies according to the ambient temperature and operating conditions; approximately 3 years in room temperature of 25°C (77°F)
Dimensions W x H x D (mm)	60 x 196 x 164
Weight (kg)	0.8



# 2

## 2.1.5 Outline and mounting dimensions

Appearance and dimension tables of NC3□□ / NC200 A series

NC3□□A-MI-A□ / NC2□□A-MI-A□

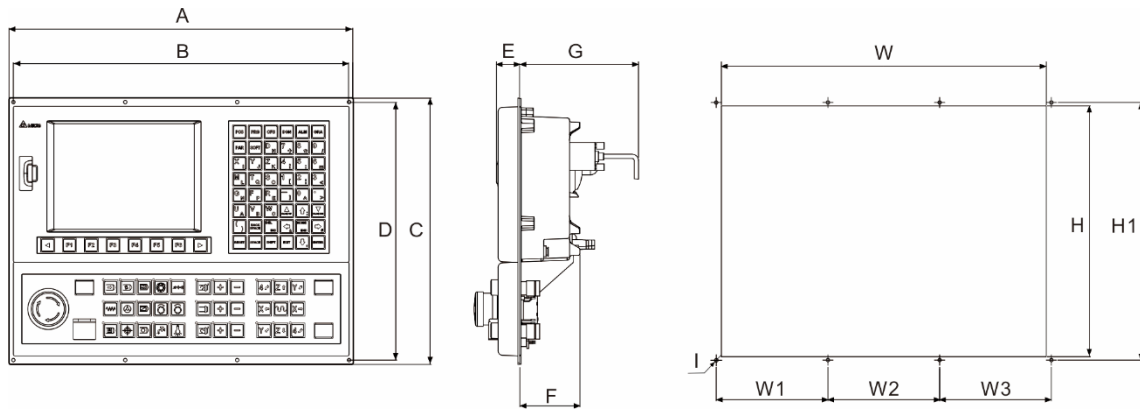

NC3□□A-MS-A□

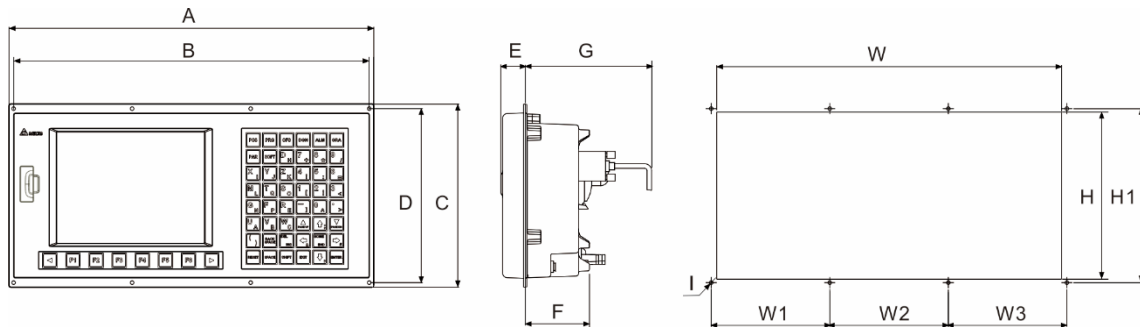

Outline dimension table

Model	NC300A-MI-A□ NC200A-MI-A□	NC300A-MS-A□	NC301A-MS-A□	NC311A-MS-A□	NC310A-MS-A□
A	400 mm	400 mm	260 mm	290 mm	435 mm
B	390 mm	390 mm	250 mm	280 mm	-
C	309 mm	200 mm	313 mm	335.5 mm	221 mm
D	299 mm	190 mm	303 mm	325.5 mm	-
E	25 mm	25 mm	21.45 mm	23 mm	23 mm
F	70 mm	70 mm	70.2 mm	70 mm	70 mm
G	130 mm	130 mm	130 mm	130 mm	130 mm

Mounting dimension table

Model	NC300A-MI-A□ NC200A-MI-A□	NC300A-MS-A□	NC301A-MS-A□	NC311A-MS-A□	NC310A-MS-A□
H	291 ± 0.3 mm	182.5 ± 0.3 mm	293 ± 0.3 mm	315.5 ± 0.3 mm	191 ± 0.3 mm
H1	299 mm	190 mm	303 mm	325.5 mm	210.4 mm
W	378 ± 0.3 mm	378 ± 0.3 mm	244 ± 0.3 mm	270 ± 0.3 mm	423 ± 0.3 mm
W1	130 mm	130 mm	250 mm	280 mm	141.47 mm
W2	130 mm	130 mm	-	-	141.47 mm
W3	130 mm	130 mm	-	-	141.47 mm
I	Φ4 mm	Φ4 mm	Φ4 mm	Φ4 mm	Φ4.5 mm

Appearance and dimension tables of A series OPENCNC

NC30E(H) dimension drawing

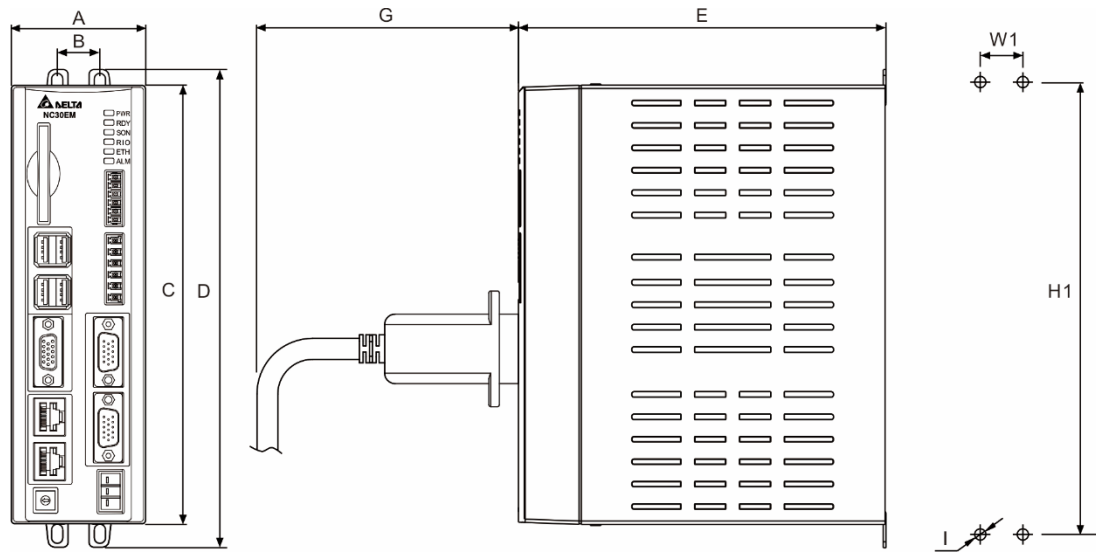

2

Outline dimension table

Model	NC30E(H)
A	60 mm
B	19 mm
C	196 mm
D	213 mm
E	164 mm
G	70 mm

Mounting dimension table

Model	NC30E(H)
H1	201 ± 0.3 mm
W1	19 ± 0.3 mm
I	M5

2

2.1.6 Operating interface installation (for OPENCNC models)

■ Operating interface installation

- A. Connect the controller to standard operating interfaces, including: (1) Delta HMI screen, (2) keyboard (functions the same as machine operation panel A), and (3) machine operation panel B.
- B. Connect the controller to non-Delta operating interfaces, including: (4) screen and (5) keyboard.

Note: the installation methods above are applicable to all NC series models, and the OPENCNC model is taken as an example in the following diagram.

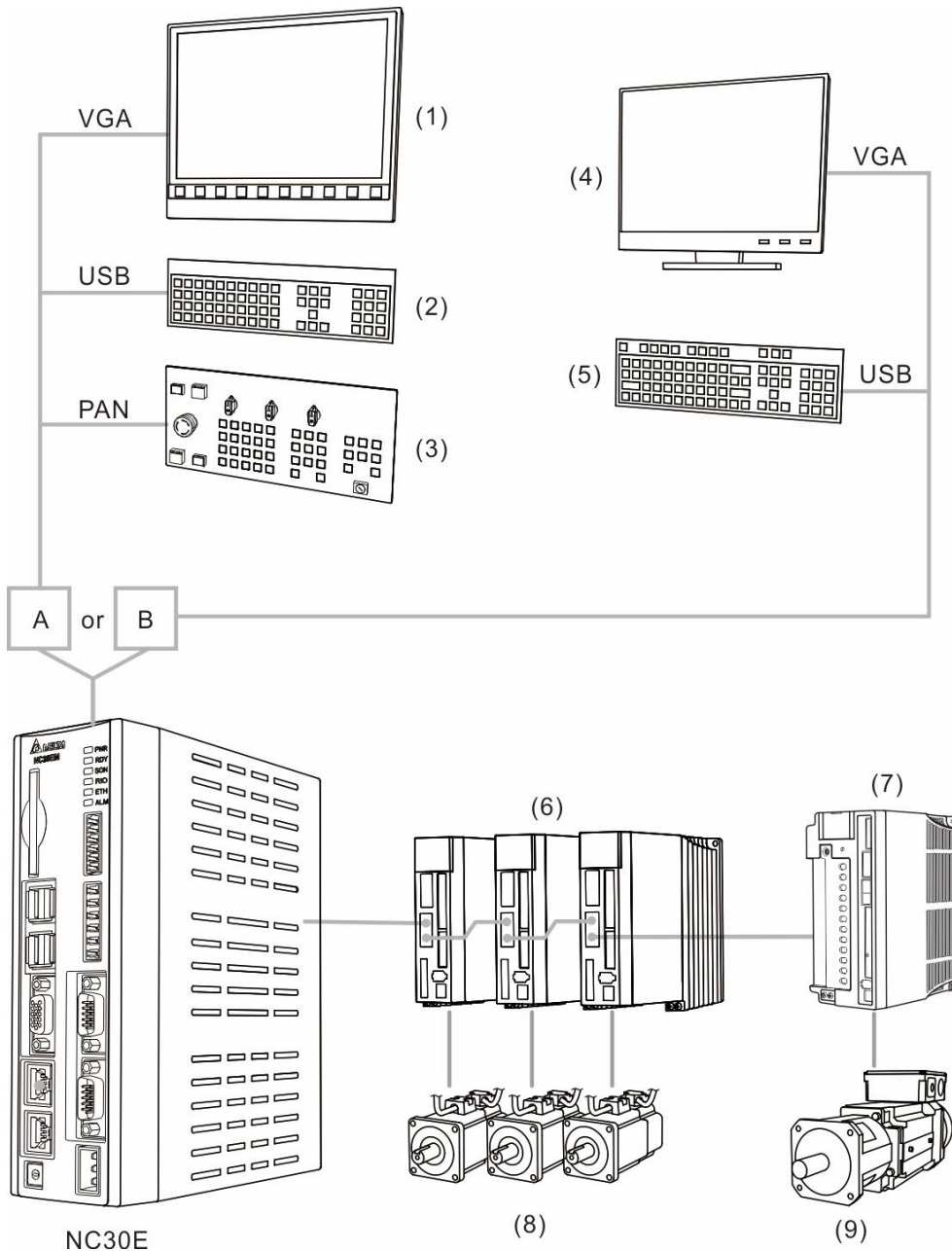

The NC series controllers can connect to (6) ASDA series AC servo drives, (7) ASDA-S spindle servo drive, (8) ECMA series servo motors, and (9) ECMS series spindle servo motor.

■ Connection through computer and network

Connect the controller to (3) ASDA series AC servo drives, (4) ASDA-S spindle servo drive, (5) ECMA series servo motors, and (6) ECMS series spindle servo motor through the computer and network, including (1) PC-based controller and (2) mouse and the public software for Delta OPENCNC.

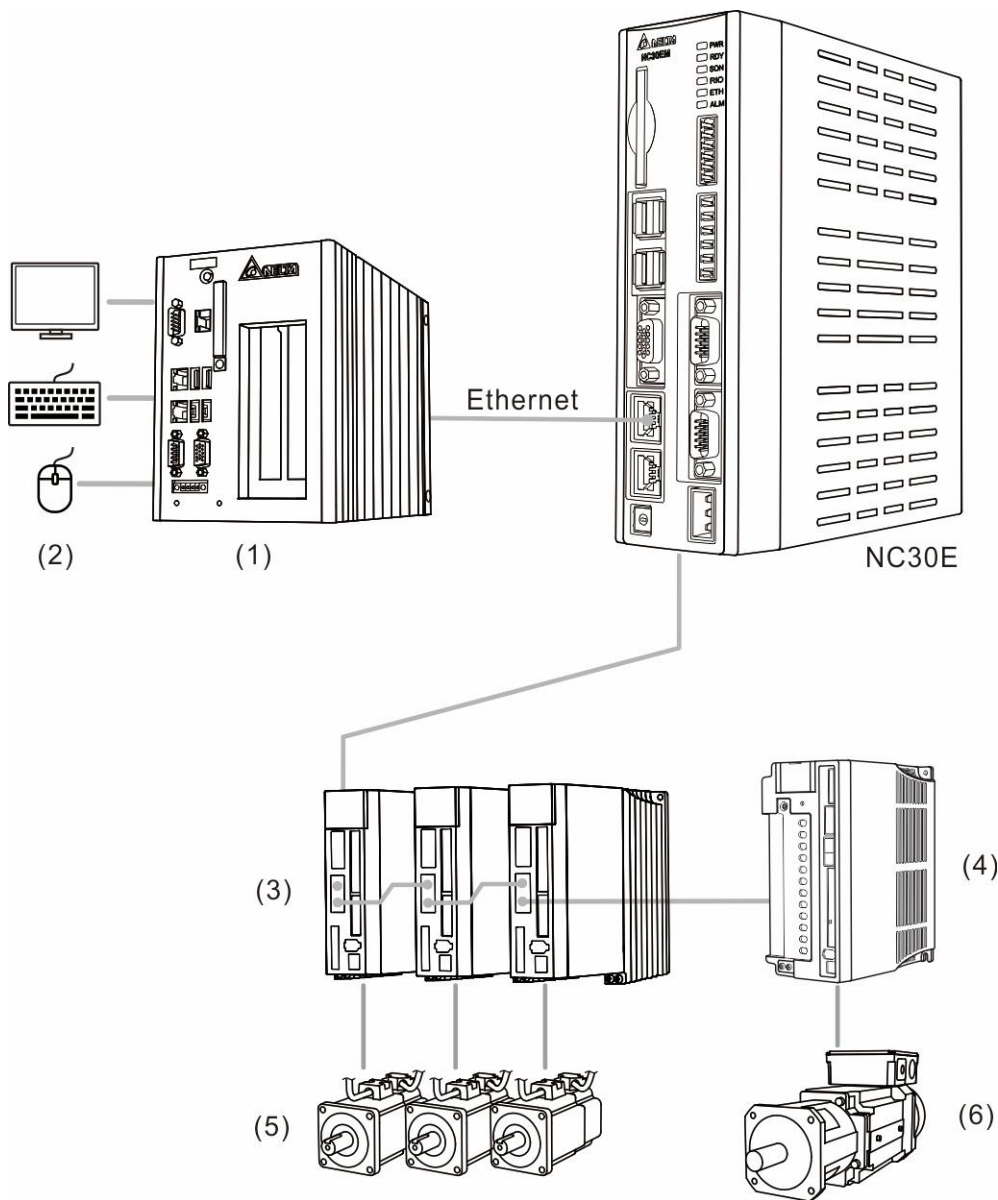

## 2

## 2.2 B series product installation explanation

### 2.2.1 Ambient storage conditions

This product must be kept in the shipping carton before installation. To retain the warranty coverage and ensure future maintenance, follow these instructions for storage. While the product is temporarily not in use:

- Store the product in a dust-free and dry location.
- Store the product in an ambient temperature range of -20°C to +60°C (-4°F to +140°F)..
- Store the product in a relative humidity range of 10% to 95% RH (non-condensing).
- Avoid storing the product in an environment containing corrosive gas and liquids.
- The environment should be free of devices that generate excessive heat; no water, vapor, dust, and oily dust; no corrosive and inflammable gas or liquids; no airborne dust or metal particles; the environment should be solid without vibration and interference of electromagnetic noise.

### 2.2.2 Ambient installation conditions

Operating temperature for the NC series controller: 0°C - 50°C (32°F - 131°F). During long-term operation, the suggested temperature of the operating environment should be below 45°C (113°F). If the temperature is above 45°C, place the product in a distribution board which is well-ventilated and without overheating risks. Also check if the vibration of the machine affects the electrical devices in the distribution board.

In addition, follow these precautions when choosing the installation site to retain the warranty coverage and ensure future maintenance for the Delta NC controller.

- The environment should be free of devices that generate excessive heat; no water, vapor, dust, and oily dust; no corrosive and inflammable gas or liquids; no airborne dust or metal particles; the environment should be solid without vibration and interference of electromagnetic noise.
- The temperature and humidity of the installation site for the NC controller should be within the range specified in the specification.
- The vibration at the location where you store the NC controller must not exceed the range specified in the specification.

### 2.2.3 Mounting direction and space

**Important:**

- The NC controller must be installed vertically on a dry and solid platform which complies with the requirement of NEMA.
- For better ventilation and cooling, allow sufficient clearance space between the NC controller and the adjacent objects and the wall (the clearance is suggested to be 50 mm (around 2 inches)), or it may cause malfunction of the machine.
- Do not block the ventilation holes of the NC controller, or it may cause malfunction of the machine.

2

### 2.2.4 Hardware specifications

NC300B series milling machine controller / NC200B series milling machine controller

Model	NC300B□-MI	NC300B□-MS	NC301B□-MS	NC310B□-MS	NC311B□-MS	NC200B□-MI
Operating environment	10% to 95% RH [0°C to +50°C (32°F to 131°F)]					
Storage environment	10% to 95% RH [-20°C to +60°C (-4°F to +140°F)]					
Cooling method	Natural cooling					
Voltage	DC +24V (-10% to +15%) (built-in isolated circuit)					
Dielectric withstanding voltage	Between 24 V <sub>DC</sub> and FG terminals: AC500V for 1 minute					
Power consumption	15 W (24V; 0.6 A)					
Battery	3V lithium battery (CR2032) × 1 Varies according to the ambient temperature and operating conditions; approximately 3 years in room temperature of 25°C (77°F)					
USB supported format	FAT16 / FAT32					
CF card supported format	FAT16 / FAT32 / EXT4 (Only for Linux)					
Dimensions W x H x D (mm)	400 x 309 x 123	400 x 200 x 97	260 x 313 x 95	435 x 221 x 95	290 x 335 x 95	400 x 309 x 123
Weight (kg)	4.1	3.1	3.4	3.8	3.8	4.3

B series OPENCNC controller

Model	NC30EB(H)
Operating environment	10% to 95% RH [0°C to +50°C (32°F to 131°F)]
Storage environment	10% to 95% RH [-20°C to +60°C (-4°F to +140°F)]
Cooling method	Natural cooling
Voltage	DC +24V (-10% to +15%) (built-in isolated circuit)
Dielectric withstanding voltage	Between 24 V <sub>DC</sub> and FG terminals: AC500V for 1 minute
Power consumption	19.2 W (24V; 0.8 A)
Battery	3V lithium battery (CR2032) × 1 Varies according to the ambient temperature and operating conditions; approximately 3 years in room temperature of 25°C (77°F)
Dimensions W x H x D (mm)	60 x 196 x 164
Weight (kg)	1.8

### 2.2.5 Outline and mounting dimensions

Appearance and dimension tables of NC3□□B series / NC200B series

NC300B□-MI-A□ / NC200B□-MI-A□

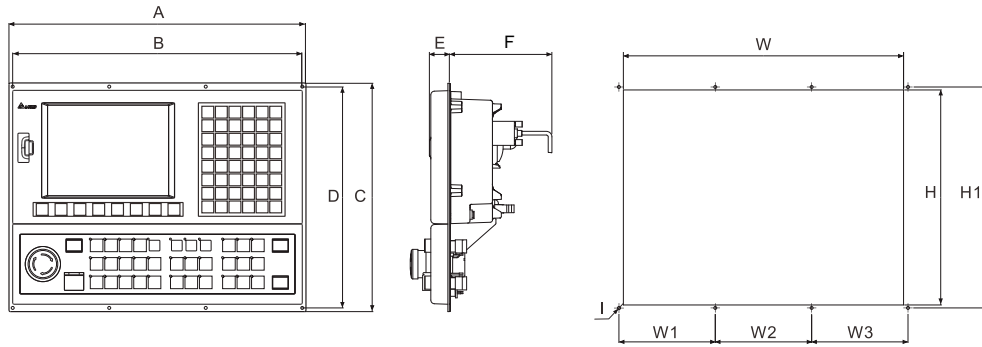

NC300B□-MS-A□

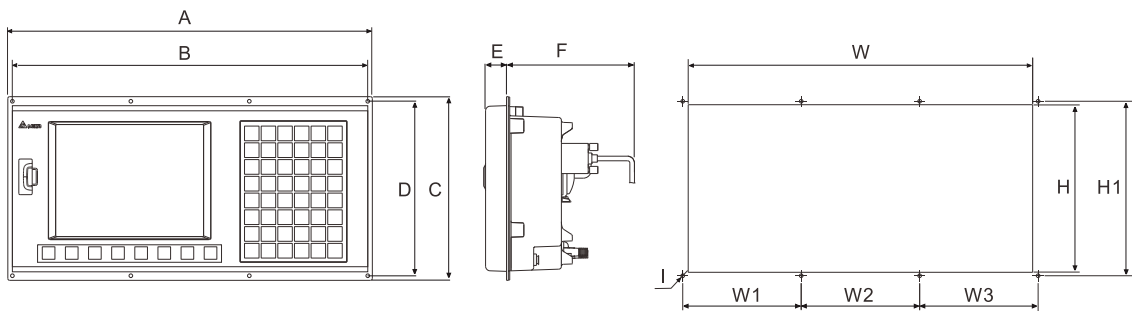

NC301B□-MS-A□

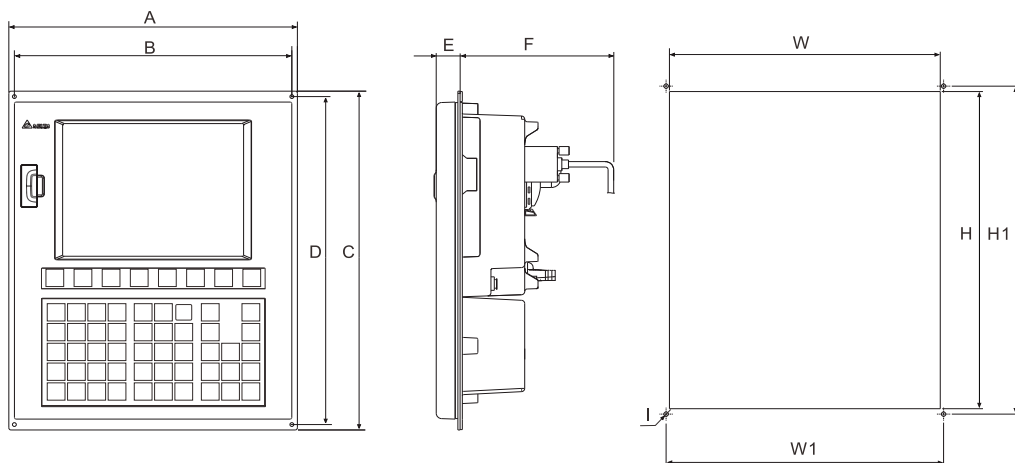



2

NC310B□-MS-A□

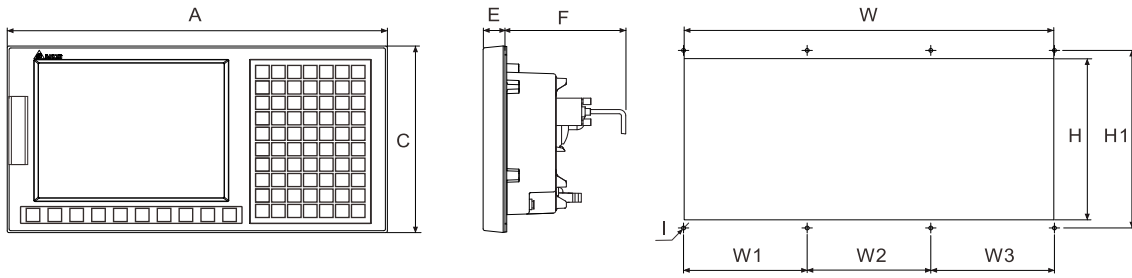

NC311B□-MS-A□

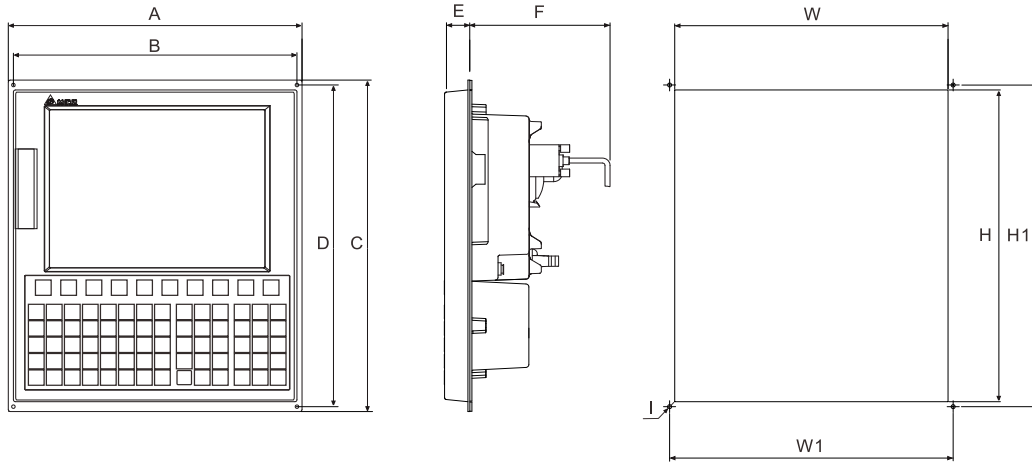

Outline dimension table

Model	NC300B□-MI-A□ NC200B□-MI-A□	NC300B□-MS-A□	NC301B□-MS-A□	NC310B□-MS-A□	NC311B□-MS-A□
A	400 mm	400 mm	260 mm	435 mm	290 mm
B	390 mm	390 mm	250 mm	-	280 mm
C	309 mm	200 mm	313 mm	221 mm	335.5 mm
D	299 mm	190 mm	303 mm	-	325.5 mm
E	25 mm	25 mm	21.45 mm	23 mm	23 mm
F	130 mm	130 mm	130 mm	130 mm	130 mm

Mounting dimension table

Model	NC300B□-MI-A□ NC200B□-MI-A□	NC300B□-MS-A□	NC301B□-MS-A□	NC310B□-MS-A□	NC311B□-MS-A□
H	291 ± 0.3 mm	182.5 ± 0.3 mm	293 ± 0.3 mm	191 ± 0.3 mm	315.5 ± 0.3 mm
H1	299 mm	190 mm	303 mm	210.4 mm	325.5 mm
W	378 ± 0.3 mm	378 ± 0.3 mm	244 ± 0.3 mm	423 ± 0.3 mm	270 ± 0.3 mm
W1	130 mm	130 mm	250 mm	141.47 mm	280 mm
W2	130 mm	130 mm	-	141.47 mm	-
W3	130 mm	130 mm	-	141.47 mm	-
I	Φ4 mm	Φ4 mm	Φ4 mm	Φ4.5 mm	Φ4 mm

Appearance and dimension tables of B series OPENCNC B

NC30EB□

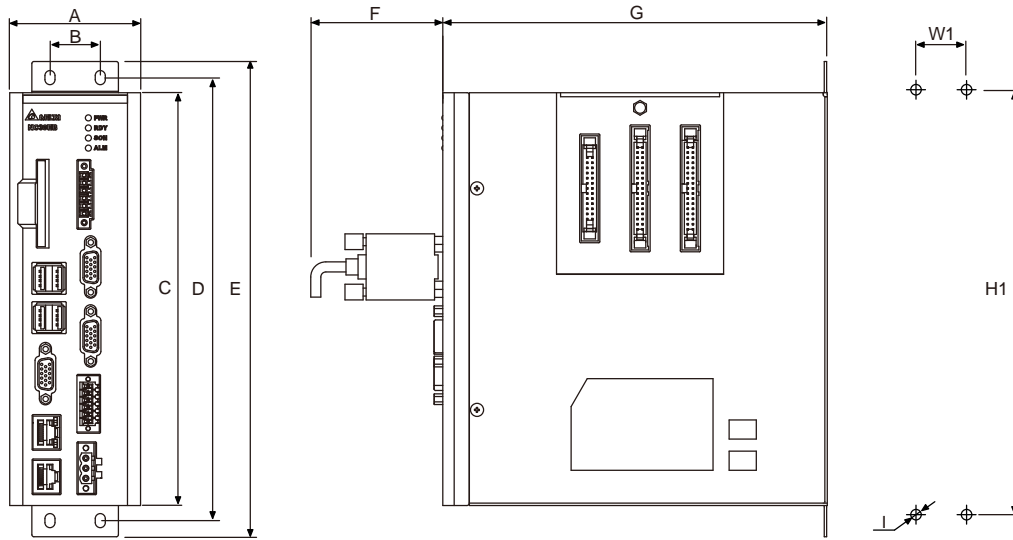

2

Outline dimension table

Model	NC30EB□
A	65 mm
B	25 mm
C	205 mm
D	220 mm
E	236 mm
F	70 mm
G	191 mm

Mounting dimension table

Model	NC30EB□
H1	220 ± 1.0 mm
W1	25 ± 0.3 mm
I	M4

# 2

## 2.2.6 Operating interface installation (for OPENCNC models)

■ Operating interface installation

- A. Connect the controller to standard operating interfaces, including: (1) Delta HMI screen, (2) keyboard (functions as the same as machine operation panel A), and (3) machine operation panel B.
- B. Connect the controller to non-Delta operating interfaces, including: (4) screen and (5) keyboard.

Note: the installation methods above are applicable to all NC series models, and the OPENCNC model is taken as an example in the following diagram.

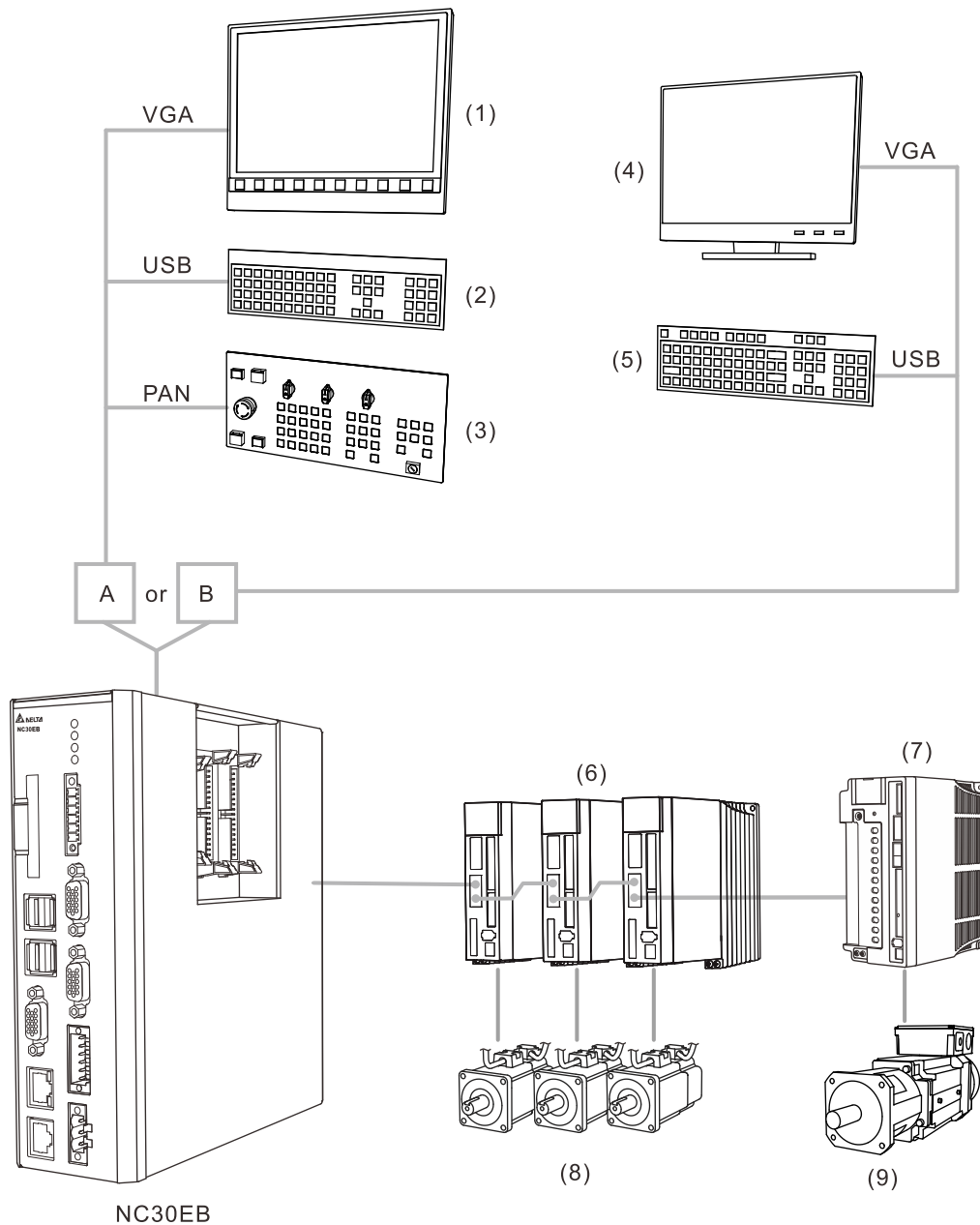

The NC series controllers can connect to the following: (6) ASDA series AC servo drives, (7) ASDA-S spindle servo drive, (8) ECMA series servo motors, and (9) ECMS series spindle servo motor.

■ Connection through computer and network

Connect the controller to (3) ASDA series AC servo drives, (4) ASDA-S spindle servo drive, (5) ECMA series servo motors, and (6) ECMS series spindle servo motor through the computer and network, including (1) PC-based controller and (2) mouse and the public software for Delta OPENCNC.

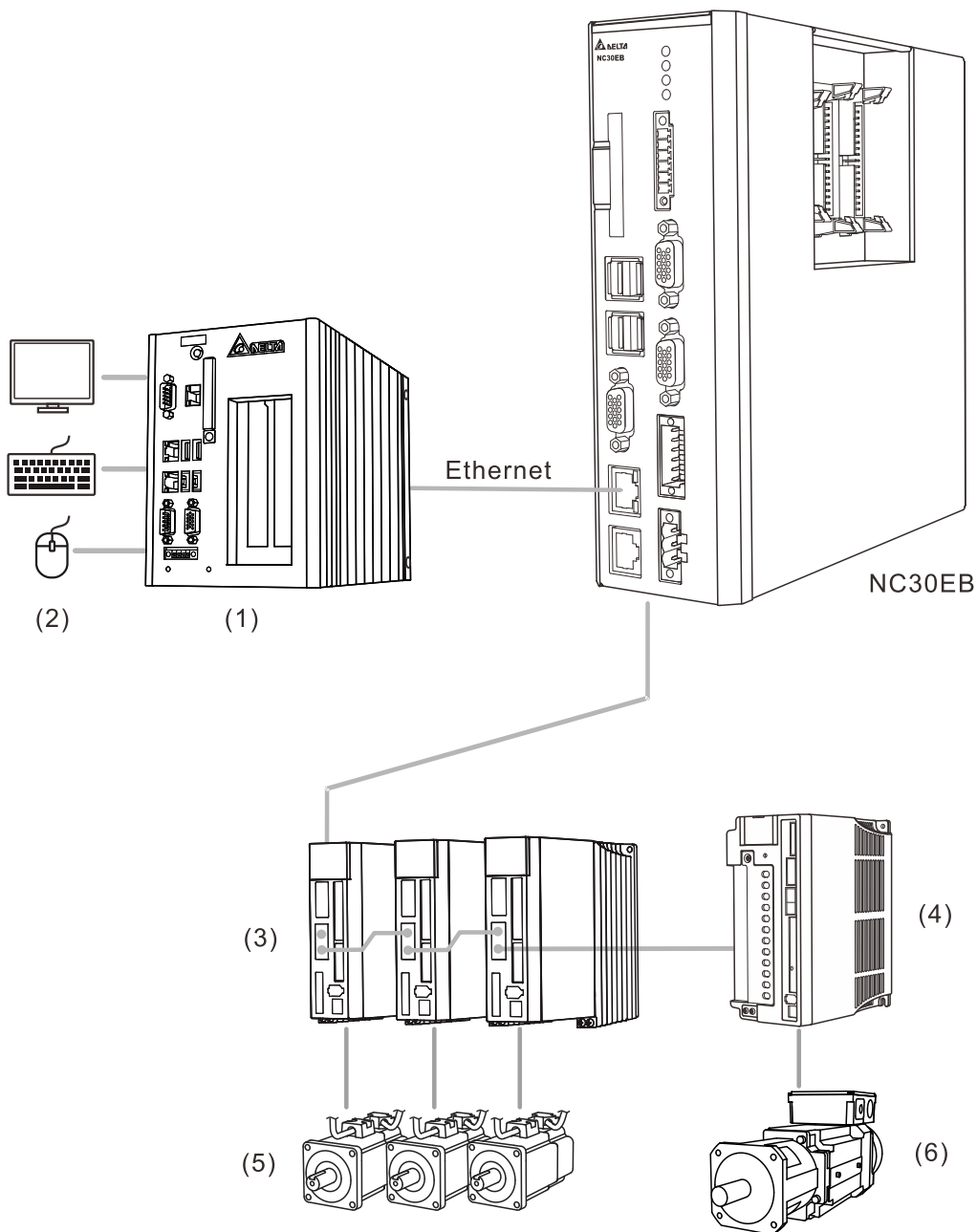

(This page is intentionally left blank.)

2

This chapter illustrates the wiring and connectors of the controller, and provides the wiring diagrams for each function.

3.1	A series product .....	3-3
3.1.1	A series system interface .....	3-3
3.1.2	A series controller connectors .....	3-10
3.1.2.1	NC3 series connectors .....	3-10
3.1.2.2	NC2 series connectors .....	3-13
3.1.2.3	OPENCNC series connectors .....	3-16
3.1.3	Wiring for power connector .....	3-18
3.1.4	Wiring for RS-485 connector .....	3-19
3.1.5	Wiring for Axis 1 - 4 input connector .....	3-21
3.1.6	Wiring for spindle feedback input connector .....	3-24
3.1.7	Wiring for spindle analog output connector .....	3-26
3.1.8	Wiring for HSI connector .....	3-29
3.1.9	Wiring for emergency stop .....	3-32
3.1.10	Wiring for MPG connector .....	3-34
3.1.11	Wiring for remote I/O connector .....	3-39
3.1.11.1	NC-EIO-R2010 .....	3-43
3.1.11.2	NC-EIO-R3216 .....	3-46
3.1.11.3	NC-EIO-R3232 .....	3-49
3.1.11.4	NC-EIO-T3232 .....	3-52
3.1.12	Wiring for local I/O connector .....	3-55
3.1.13	Wiring for I/O connector on machine operation panel B of NC300 / NC310 series models .....	3-57
3.1.14	Wiring for I/O connector on machine operation panel B of NC311 series models .....	3-60
3.2	B series product .....	3-63
3.2.1	B series system interface .....	3-63
3.2.2	B series controller connectors .....	3-73
3.2.2.1	NC3□□B series connectors .....	3-73
3.2.2.2	NC200B series connectors .....	3-76
3.2.2.3	OPENCNC series connectors .....	3-78
3.2.3	Wiring for power connector .....	3-80

## 3

3.2.4	Wiring for spindle pulse output connector .....	3-81
3.2.5	Wiring for RS-485 connector .....	3-84
3.2.6	Wiring for spindle analog feedback connector .....	3-86
3.2.7	Wiring for spindle analog output connector .....	3-88
3.2.8	Wiring for HSI connector .....	3-91
3.2.9	Wiring for emergency stop .....	3-93
3.2.10	Wiring for MPG connector .....	3-94
3.2.11	Wiring for remote I/O connector .....	3-98
3.2.11.1	NC-EIO-R2010 .....	3-102
3.2.11.2	NC-EIO-R3216 .....	3-105
3.2.11.3	NC-EIO-R3232 .....	3-108
3.2.11.4	NC-EIO-T3232 .....	3-111
3.2.12	Wiring for local I/O connector .....	3-114
3.2.13	Wiring for I/O connector on machine operation panel B of NC3□□ series models .....	3-119

### 3.1 A series product

#### 3.1.1 A series system interface

- NC3 series

NC300A \_MI-A\_

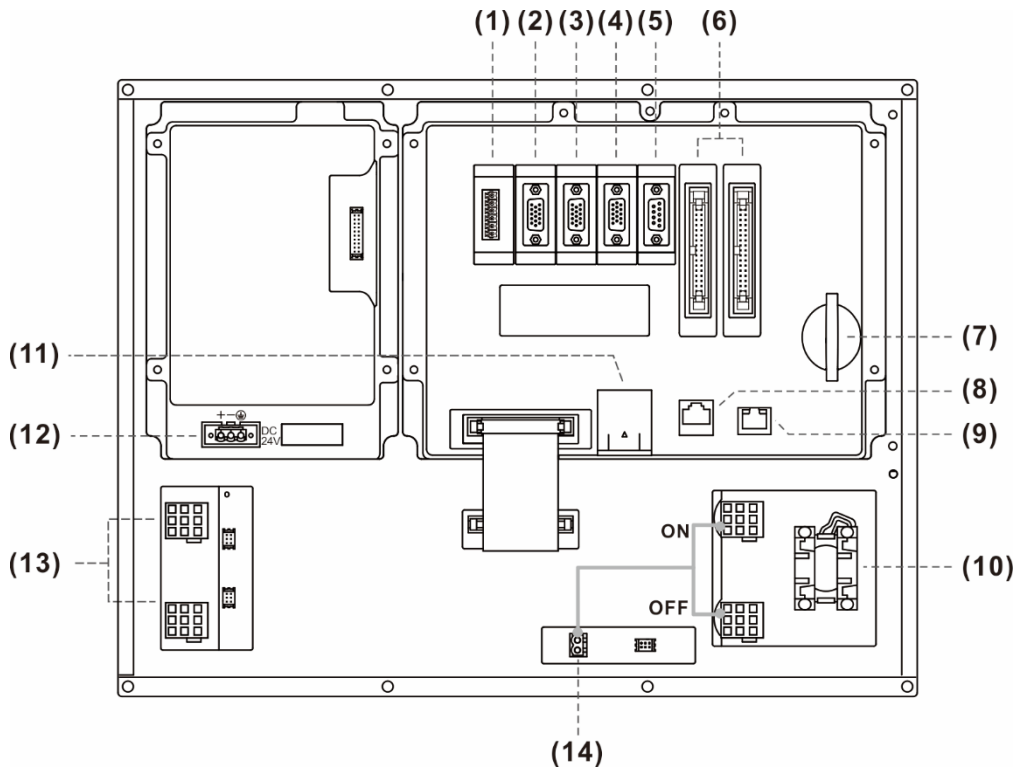

NC300A \_MS-A\_

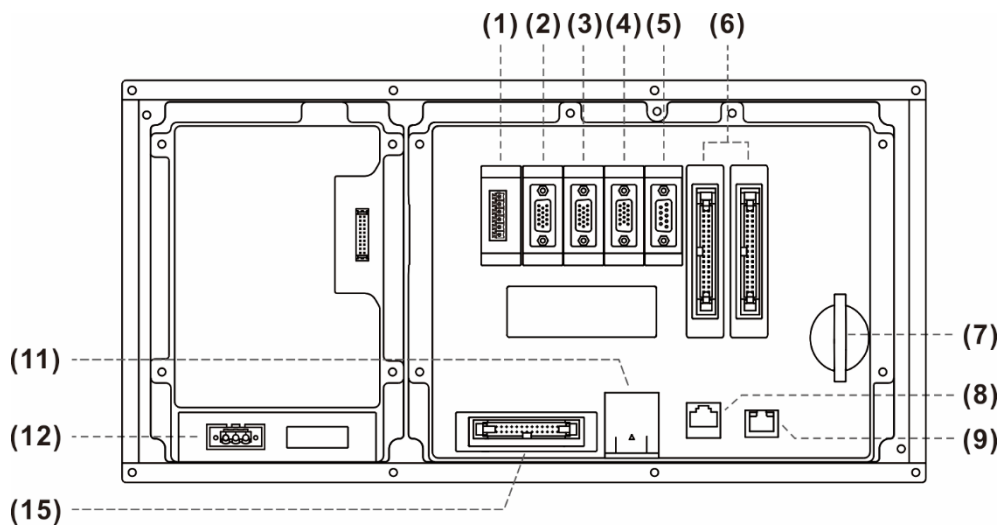



## Detailed description of each connector

No.	Connector	Description
(1)	Remote I/O	Connects to high-speed serial I/O module: each module has 32 DI and 32 DO points. The maximum distance between stations is 20 m and the total length can be up to 160 m (= 20 m x 8).
(2)	MPG	Connects to an external MPG (powered by the built-in 5 V <sub>DC</sub> power). 8 DI points are available.
(3)	Spindle	One set of spindle encoder input signal. One set of analog output signal. G31 analog output signal.
(4)	Axis 1 - 4	Limit and home inputs of four axes.
(5)	RS-485	RS-485 serial port for communication with external devices.
(6)	Local I/O	I/O 1: 16 DI / 16 DO points. I/O 2: 12 DI / 12 DO points.
(7)	CF card	For storing G-code programs.
(8)	DMCNET	High-speed communication network connector.
(9)	Ethernet	For DNC control and system monitoring.
(10)	Emergency stop	When the button is pressed, the IES circuit is open, causing the system to stop immediately.
(11)	Battery holder	-
(12)	24 V <sub>DC</sub> power	24 V <sub>DC</sub> power input for supplying 24 V <sub>DC</sub> power to the controller.
(13)	CYCLE START / FEED HOLD	-
(14)	24 V <sub>DC</sub> power	For supplying 24 V <sub>DC</sub> power to machine operation panel B.
(15)	Cable slot for machine operation panel B	-

## Safety precautions for installation:

1. Check if the wiring for 24 V<sub>DC</sub> power is correct.
2. Both local I/O and remote I/O require an additional 24 V<sub>DC</sub> power supply to drive X input and Y output.
3. Short-circuit EMG (emergency stop) to have the controller ready for use.
4. If an alarm occurs or the emergency stop signal is on, power off the servo drive by disconnecting the power at the magnetic contactor (MC) with Y output.

NC301A-MS-A

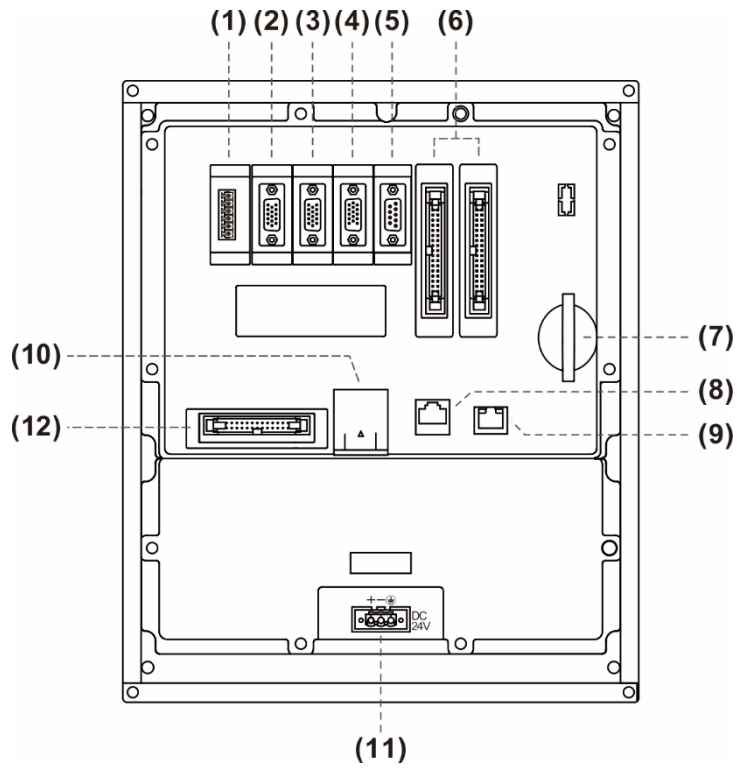

NC310A-MS-A

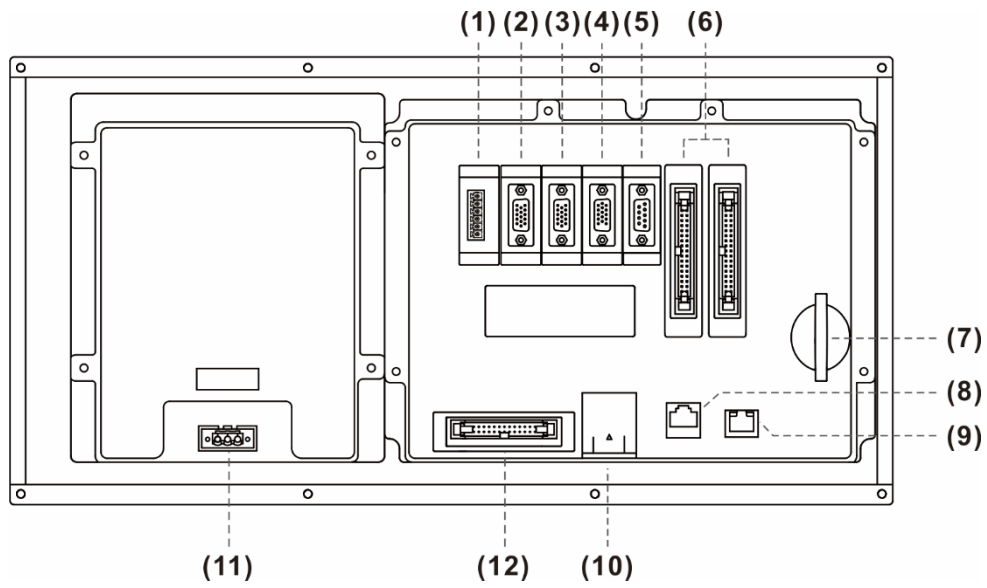

NC311A-MS-A

3

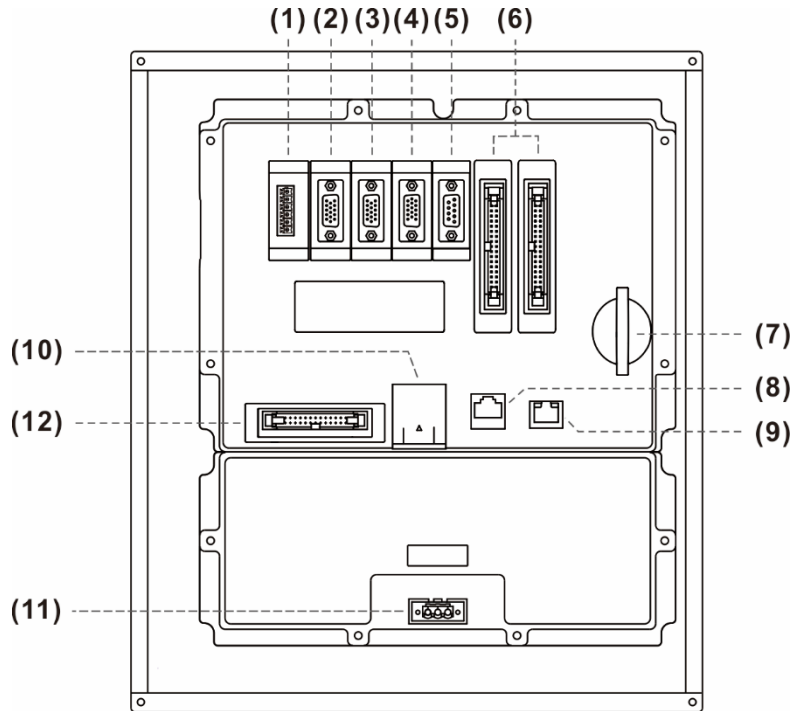

Detailed description of each connector

No.	Connector	Description
(1)	Remote I/O	Connects to high-speed serial I/O module: each module has 32 DI and 32 DO points. The maximum distance between stations is 20 m and the total length can be up to 160 m (= 20 m x 8).
(2)	MPG	Connects to an external MPG (powered by the built-in 5 V <sub>DC</sub> power). 8 DI points are available.
(3)	Spindle	One set of spindle encoder input signal. One set of analog output signal. G31 analog output signal.
(4)	Axis 1 - 4	Limit and home inputs of four axes.
(5)	RS-485	RS-485 serial port for communication with external devices.
(6)	Local I/O	I/O 1: 16 DI / 16 DO points. I/O 2: 12 DI / 12 DO points.
(7)	CF card	For storing G-code programs.
(8)	DMCNET	High-speed communication network connector.
(9)	Ethernet	For DNC control and system monitoring.
(10)	Battery holder	-
(11)	24 V <sub>DC</sub> power	24 V <sub>DC</sub> power input for supplying 24 V <sub>DC</sub> power to the controller.
(12)	Cable slot for machine operation panel B	-

Safety precautions for installation:

1. Check if the wiring for 24 V<sub>DC</sub> power is correct.
2. Both local I/O and remote I/O require an additional 24 V<sub>DC</sub> power supply to drive X input and Y output.
3. Short-circuit EMG (emergency stop) to have the controller ready for use.
4. If an alarm occurs or the emergency stop signal is on, power off the servo drive by disconnecting the power at the magnetic contactor (MC) with Y output.

■ NC2 series

NC200A-MI-A

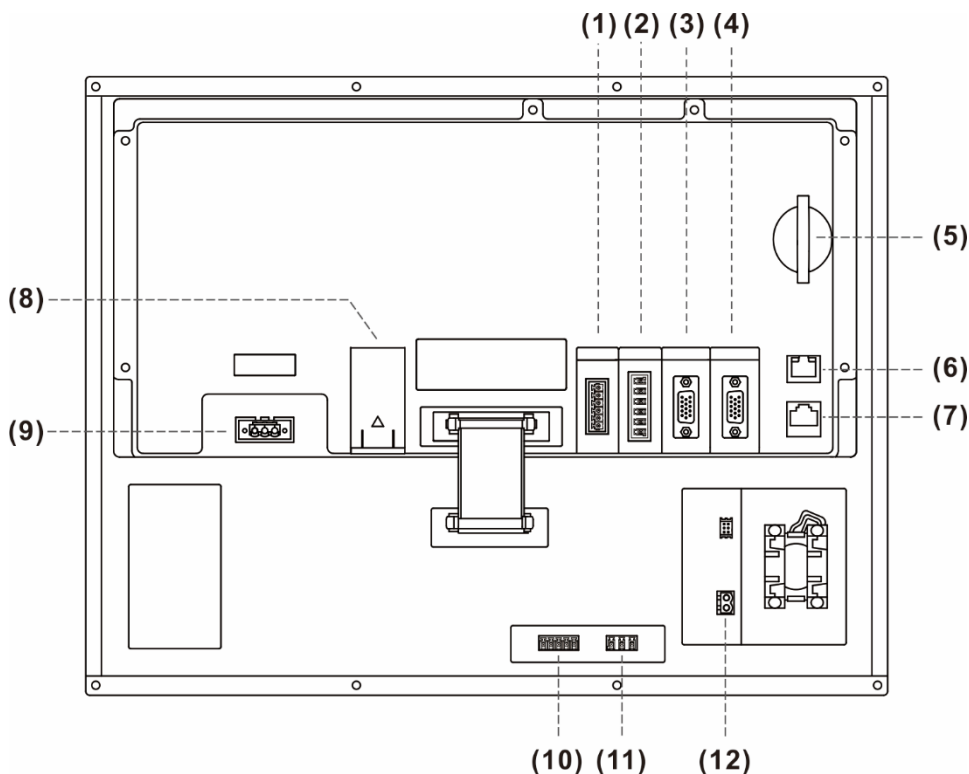

Detailed description of each connector

No.	Connector	Description
(1)	Remote I/O	Connects to high-speed serial I/O module: each module has 32 DI and 32 DO points. The maximum distance between stations is 20 m and the total length can be up to 160 m (= 20 m x 8).
(2)	HSI	High-speed counter and emergency stop input signal.
(3)	Spindle	One set of spindle encoder input signal. One set of analog output signal. One set of RS-485 serial communication signal.
(4)	MPG	Connects to an external MPG (powered by the built-in 5 V <sub>DC</sub> power). 7 DI points and 1 DO point are available.
(5)	CF card	For storing G-code programs.
(6)	Ethernet	For DNC control and system monitoring.
(7)	DMCNET	High-speed communication network connector.
(8)	Battery holder	-
(9)	24 V <sub>DC</sub> power	24 V <sub>DC</sub> power input for supplying 24 V <sub>DC</sub> power to the controller.
(10)	Local I/O input terminal	5 input points.
(11)	Local I/O output terminal	3 output points.
(12)	24 V <sub>DC</sub> power	For supplying 24 V <sub>DC</sub> power to machine operation panel B.

Safety precautions for installation:

1. Check if the wiring for 24 V<sub>DC</sub> power is correct.
2. Remote I/O requires an additional 24 V<sub>DC</sub> power supply to drive X input and Y output.
3. Short-circuit IES (emergency stop) to have the controller ready for use.
4. If an alarm occurs or the emergency stop signal is on, power off the servo drive by disconnecting the power at the magnetic contactor (MC) with Y output.

3

■ OPENCNC series

NC30E(H)

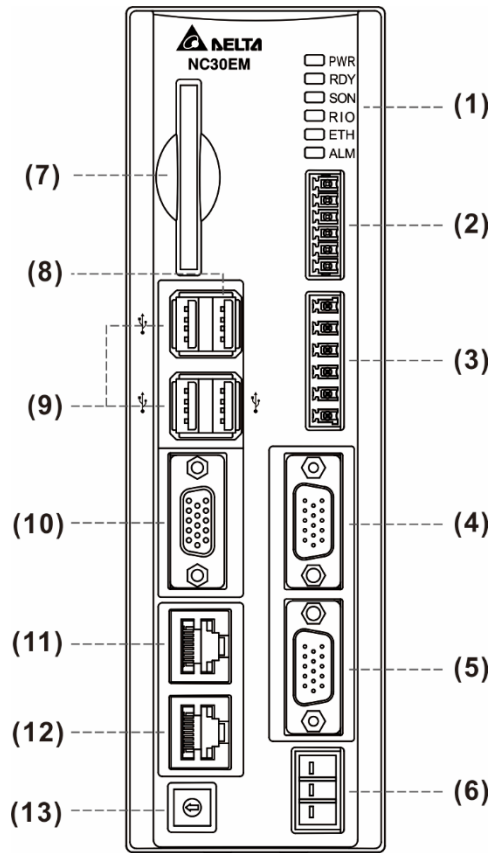

Detailed description of each connector

No.	Connector	Description
(1)	Indicators	-
(2)	Remote I/O	Connects to high-speed serial I/O module: each module has 32 DI and 32 DO points. The maximum distance between stations is 20 m and the total length can be up to 160 m (= 20 m x 8).
(3)	HSI	High-speed counter and emergency stop signal input.
(4)	MPG	Connects to an external MPG (powered by the built-in 5 V <sub>DC</sub> power). 8 DI points are available.
(5)	Spindle	One set of spindle encoder input signal. One set of analog output signal. One set of RS-485 serial communication signal.
(6)	24 V <sub>DC</sub> power	24 V <sub>DC</sub> power input for supplying 24 V <sub>DC</sub> power to the controller.
(7)	CF card	For storing G-code programs.
(8)	PAN	One USB connector for connecting to machine operation panel B.
(9)	USB	Three USB host connectors for connecting to the mouse, keyboard, and flash drive.
(10)	VGA	For connecting to a screen.
(11)	Ethernet	Ethernet connector.
(12)	DMCNET	High-speed communication network connector.
(13)	MODE	For switching the debugging mode.

Debugging mode description

Setting value	Mode	
0	Standard mode	
	Indicator description:	
	PWR	Green: system power on
	RDY	Flashing green: system ready Orange: in modes 1 - 3
	SON	Green: system ready
	RIO	Green: remote I/O connection is normal
	ETH	Green: network communication is normal
ALM	Red: system alarm occurs Flashing green: software updating	
1	System update mode	
2	Default mode	
3	Reset IP to default setting	
	Default IP:	
	Controller IP	192.168.1.11
	Subnet mask	255.255.255.0
	Remote PC IP	192.168.1.10



Safety precautions for installation:

1. Check if the wiring for 24 V<sub>DC</sub> power is correct.
2. Remote I/O requires an additional 24 V<sub>DC</sub> power supply to drive X input and Y output.
3. If an alarm occurs or the emergency stop signal is on, power off the servo drive by disconnecting the power at the magnetic contactor (MC) with Y output.

3

3.1.2 A series controller connectors

3.1.2.1 NC3 series connectors

Symbol	Function	Description		
0V, +24V, 	Power input for controller	Connects to the 24 V <sub>DC</sub> power (15 W at 0.6 A).		
		Symbol	Cable color	Description
		+24V	Red	+24 V <sub>DC</sub> power
		0V	White	0 V <sub>DC</sub> power
		Green	Power grounding	
I/O 1	1 <sup>st</sup> set local I/O	DI/DO range: X0 - X15, Y0 - Y15.		
		Pin No.	Description	
		P1 - P16	DI points X0 - X15, 16 points in total (8 - 25 mA)	
		P19 - P34	DO points Y0 - Y15, 16 points in total (< 120 mA)	
		P18	DI COM point; connects to +24 V <sub>DC</sub> or 0V	
		P17	DO COM point; fixed at 0V	
Power specifications: voltage < 24 V <sub>DC</sub> , current < 60 mA.				
I/O 2	2 <sup>nd</sup> set local I/O	DI/DO range: X16 - X27, Y16 - Y27.		
		Pin No.	Description	
		P1 - P12	DI points X16 - X27, 12 points in total (8 - 25 mA)	
		P19 - P30	DO points Y16 - Y27, 12 points in total (< 120 mA)	
		P18	DI COM point; connects to +24 V <sub>DC</sub> or 0V	
		P17	DO COM point; fixed at 0V	
Power specifications: voltage < 24 V <sub>DC</sub> , current < 60 mA.				
Axis 1 - 4	Limit and home sensor of each axis	Each axis (1 - 4) has positive / negative limit and home sensor input terminals, 12 points in total (operating current: 8 - 25 mA).		
		Pin No.	Description	
		P1 - P3	Positive limit, negative limit, and home point inputs of the 1 <sup>st</sup> axis (Special M [M2144], [M2145], [M2146])	
		P4 - P6	Positive limit, negative limit, and home point inputs of the 2 <sup>nd</sup> axis (Special M [M2148], [M2149], [M2150])	
		P7 - P9	Positive limit, negative limit, and home point inputs of the 3 <sup>rd</sup> axis (Special M [M2152], [M2153], [M2154])	
		P10 - P12	Positive limit, negative limit, and home point inputs of the 4 <sup>th</sup> axis (Special M [M2156], [M2157], [M2158])	
P13 - P15	DI COM point; connects to +24 V <sub>DC</sub> or 0V			



Symbol	Function	Description	
SPINDLE	Spindle connector	Includes spindle feedback, analog output, and 2 high-speed inputs.	
		Pin No.	Description
		P1	HSI_COM; connects to +24 V <sub>DC</sub> or 0V
		P2	HSI_1 (Counter C78, enter [M2142])
		P3	HSI_2 (Counter C79, enter [M2143])
		P4	SP_OUT
		P5	SP_GND
		P6	EMG_GND
		P7	EMG_IN
		P8	SP_A+
		P9	SP_A-
		P10	DC +5V_OUT
		P11	SP_B+
		P12	SP_B-
		P13	SP_Z+
		P14	SP_Z-
P15	GND		
MPG	MPG connector	6 DI points and 1 set of differential type MPG signal input.	
		Pin No.	Description
		P1	DI_COM; connects to +24 V <sub>DC</sub> or 0V
		P2 - P9	DI (X28 - X35)
		P10	DC +5V_OUT (< 200 mA)
		P11	XA+
		P12	XA-
		P13	XB+
		P14	XB-
P15	GND		
REMOTE I/O	Remote I/O module serial communication terminal	Remote I/O module communication signals, including X256 - X511 and Y256 - Y511. Each module has 32 X inputs and 32 Y outputs, and the controller can connect to up to 8 modules.	
		Pin No.	Description
		P1	TX+
		P2	TX-
		P3	RX-
		P4	RX+
		P5	GND
P6	SHIELD		



3

Symbol	Function	Description	
ETHERNET	Ethernet connector	Connects to PC with an RJ45 connector and a network cable. Pin definition of both ends:	
		Pin No. / color of end A	Pin No. / color of end B
		1: orange & white	1: orange & white
		2: orange	2: orange
		3: green & white	3: green & white
		4: blue	4: blue
		5: blue & white	5: blue & white
		6: green	6: green
		7: brown & white	7: brown & white
	8: brown	8: brown	
DMCNET	DMCNET connector	Connects to Delta's DMCNET servo drive with standard RJ45 connector. The wiring method is the same as that of the Ethernet connector.	
EMG	Emergency stop	Press to make an open circuit during emergencies.	
Power On	Power On connector	Power On button contact.	
Power Off	Power Off connector	Power Off button contact.	
IES	Emergency stop contact	The emergency stop contact. The EMG flag is enabled in a broken circuit. (Wired to the normally-closed contact of the emergency stop button.)	
RS-485	RS-485 serial communication port	Connects to external devices using RS-485 serial communication.	

3.1.2.2 NC2 series connectors

Symbol	Function	Description	
0V, +24V, 	Power input for controller	Connects to the 24 V <sub>DC</sub> power (15 W at 0.6 A).	
		Symbol	Description
		+24V	+24 V <sub>DC</sub> power
		0V	0 V <sub>DC</sub> power
	Power grounding		
0V, +24V	Power input for machine operation panel B	Connects to the 24 V <sub>DC</sub> power (15 W at 0.6 A).	
		Symbol	Description
		+24V	+24 V <sub>DC</sub> power
0V	0 V <sub>DC</sub> power		
I/O	DI	Power specifications for DI points: voltage < 24 V <sub>DC</sub> , current: 8 - 25 mA.	
		MI series	
		Pin No.	Description
		X112 - X116	DI points X112 - X116, 5 points in total.
		LI series	
	DO	Power specifications for DO points: voltage < 24 V <sub>DC</sub> , current < 120 mA.	
		MI series	
		Pin No.	Description
		Y112 - Y114	DO points Y112 - Y114, 3 points in total.
		LI series	
SPINDLE	Spindle connector	Includes spindle feedback, analog output, and 1 set of RS-485 serial communication input.	
		Pin No.	Description
		P1	RS485_GND
		P2	RS485_D+
		P3	RS485_D-
		P4	SP_OUT
		P5	SP_GND
		P6	Reserved
		P7	EMG_IN; connects to +24 V <sub>DC</sub>
		P8	SP_A+
		P9	SP_A-
		P10	DC +5V_OUT
		P11	SP_B+
		P12	SP_B-
		P13	SP_Z+
P14	SP_Z-		
P15	GND		

3

Symbol	Function	Description	
MPG	MPG connector	7 DI points, 1 DO point, and 1 set of differential type MPG input signal.	
		Pin No.	Description
		P1	DI_COM; connects to +24 V <sub>DC</sub> or 0V
		P2 - P7	DI (X28 - X33)
		P8	DI (X26)
		P9	DO (Y27)
		P10	DC +5V_OUT (< 200 mA)
		P11	XA+
		P12	XA-
		P13	XB+
		P14	XB-
		P15	GND
HSI	High-speed counter and emergency stop input signal	2 sets of high-speed and 1 set of emergency stop input signals.	
		Pin No.	Description
		P1	EMG_IN
		P2	EMG_GND
		P3	HSI_1 (Counter C78, enter [M2142])
		P4	HSI_COM; connects to +24 V <sub>DC</sub> or 0V
		P5	HSI_2 (Counter C79, enter [M2143])
P6	HSI_COM; short-circuit P4 and P6		
REMOTE I/O	Remote I/O module serial communication terminal	Remote I/O module communication terminal, including X256 - X511 and Y256 - Y511. Each module has 32 X inputs and 32 Y outputs, and the controller can connect to up to 8 modules.	
		Pin No.	Description
		P1	TX+
		P2	TX-
		P3	RX-
		P4	RX+
		P5	GND
P6	SHIELD		



Symbol	Function	Description	
ETHERNET	Ethernet connector	Connects to PC with an RJ45 connector and a network cable. Pin definition of both ends:	
		Pin No. / color of end A	Pin. No. / color of end B
		1: orange & white	1: orange & white
		2: orange	2: orange
		3: green & white	3: green & white
		4: blue	4: blue
		5: blue & white	5: blue & white
		6: green	6: green
		7: brown & white	7: brown & white
		8: brown	8: brown
DMCNET	DMCNET connector	Connect to Delta's DMCNET servo drive with standard RJ45 connector. The wiring method is the same as that of the Ethernet connector.	
EMG	Emergency stop	Press to make an open circuit during emergencies.	
Power On	Power On connector	Power On button contact.	
Power Off	Power Off connector	Power Off button contact.	
IES	Emergency stop contact	The emergency stop contact. The EMG flag is enabled in a broken circuit. (Wire it to the normally-closed contact of the emergency stop button.)	

## Note:

1. The IES connector is the input contact of the emergency stop signal. Enable the EMG flag in a broken circuit.
2. The power for the lights of Power On and Power Off buttons is 24 V<sub>DC</sub>.

3

3.1.2.3 OPENCNC series connectors

Symbol	Function	Description	
0V, +24V, 	Power input for controller	Connects to the 24 V <sub>DC</sub> power (15 W at 0.6 A).	
		Symbol	Description
		+24V	+24 V <sub>DC</sub> power
		0V	0 V <sub>DC</sub> power
		Power grounding	
SPINDLE	Spindle connector	Includes spindle feedback, analog output, and 1 set of RS-485 serial communication input.	
		Pin No.	Description
		P1	RS485_GND
		P2	RS485_D+
		P3	RS485_D-
		P4	SP_OUT
		P5	SP_GND
		P6	Reserved
		P7	Reserved
		P8	SP_A+
		P9	SP_A-
		P10	DC +5V_OUT
		P11	SP_B+
		P12	SP_B-
		P13	SP_Z+
P14	SP_Z-		
P15	GND		
MPG	MPG connector	8 DI points and 1 set of differential type MPG signal input.	
		Pin No.	Description
		P1	DI_COM; connects to +24 V <sub>DC</sub> or 0V
		P2 - P9	DI (X28 - X35)
		P10	DC +5V_OUT (< 200 mA)
		P11	XA+
		P12	XA-
		P13	XB+
		P14	XB-
P15	GND		

Symbol	Function	Description	
HSI	High-speed counter and emergency stop input signal	2 sets of high-speed and 1 set of emergency stop input signals.	
		Pin No.	Description
		P1	EMG_IN (DC+ 5V output)
		P2	MODE_ENABLE (DC+ 5V output)
		P3	HSI_1 (Counter C78, enter [M2142])
		P4	GND
		P5	HSI_2 (Counter C79, enter [M2143])
P6	HSI_COM; connects to +24 V <sub>DC</sub> or 0V		
REMOTE I/O	Remote I/O module serial communication terminal	Remote I/O module communication signals, including X256 - X511 and Y256 - Y511. Each module has 32 X inputs and 32 Y outputs, and of the controller can connect to up to 8 modules.	
		Pin No.	Description
		P1	TX+
		P2	TX-
		P3	RX-
		P4	RX+
P5	GND		
P6	SHIELD		
PAN2	Connector for machine operation panel B	The USB host connector for connecting to machine operation panel B. No connection to USB devices.	
USB	USB connector	USB connectors for connecting to USB devices, such as USB flash drive, mouse, and keyboard. Connection in series is not supported by this connector.	
VGA	VGA connector	Connects to an external monitor (only monitors with the refresh rate of 60 Hz is supported).	
ETHERNET	Ethernet connector	Connects to PC with an RJ45 connector and a network cable. Pin definition of both ends:	
		Pin No. / color of end A	Pin No. / color of end B
		1: orange & white	1: orange & white
		2: orange	2: orange
		3: green & white	3: green & white
		4: blue	4: blue
		5: blue & white	5: blue & white
		6: green	6: green
7: brown & white	7: brown & white		
8: brown	8: brown		
DMCNET	DMCNET connector	Connects to Delta's DMCNET servo drive with standard RJ45 connector. The wiring method is the same as that of the Ethernet connector.	
MODE	Debugging mode	Debugging mode switch.	

3

### 3.1.3 Wiring for power connector

The wiring for the power of the NC series controller is divided into two types: power supply control with Power On / Off switches and direct power supply.

- Power supply control with Power On / Off switches

As shown in the following figure, Power On is the NO contact and Power Off is the NC contact; MC (electromagnetic contactor) is the power relay.

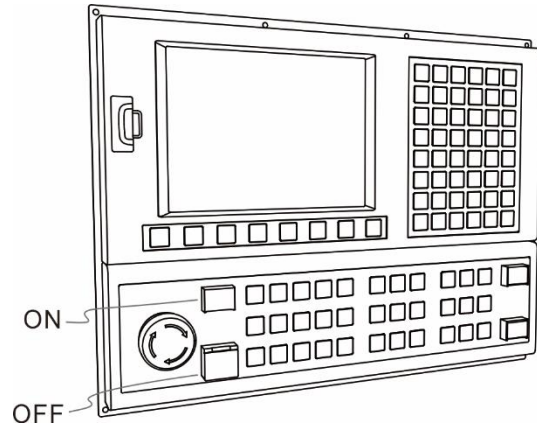
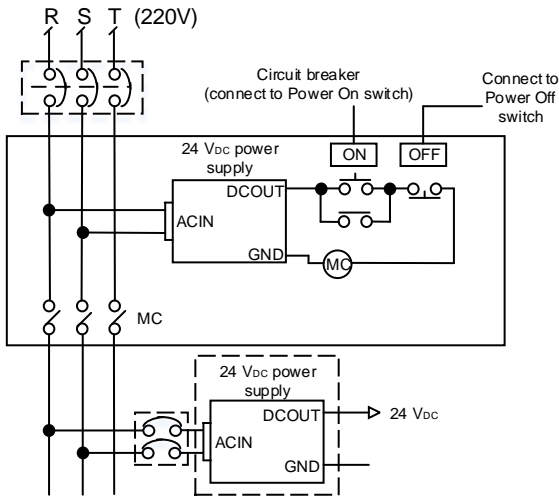

- Direct power supply

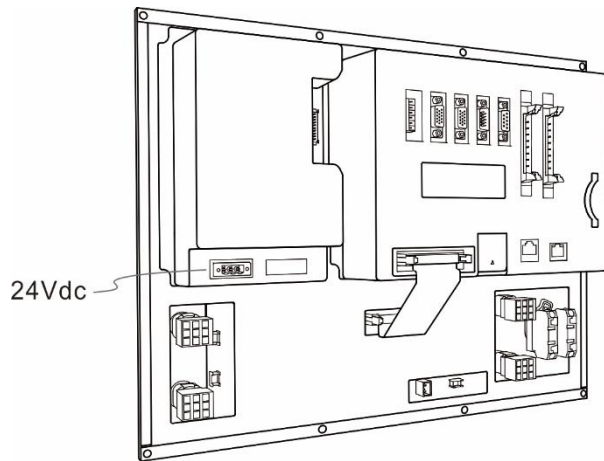
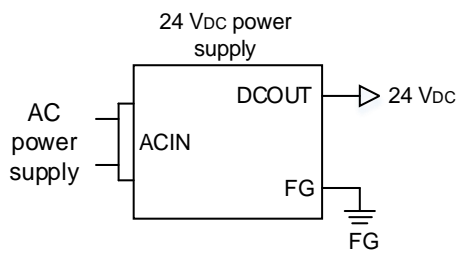

### 3.1.4 Wiring for RS-485 connector

The NC series controller has one RS-485 connector for serial communication with external devices.

Pin assignment for NC3 series models

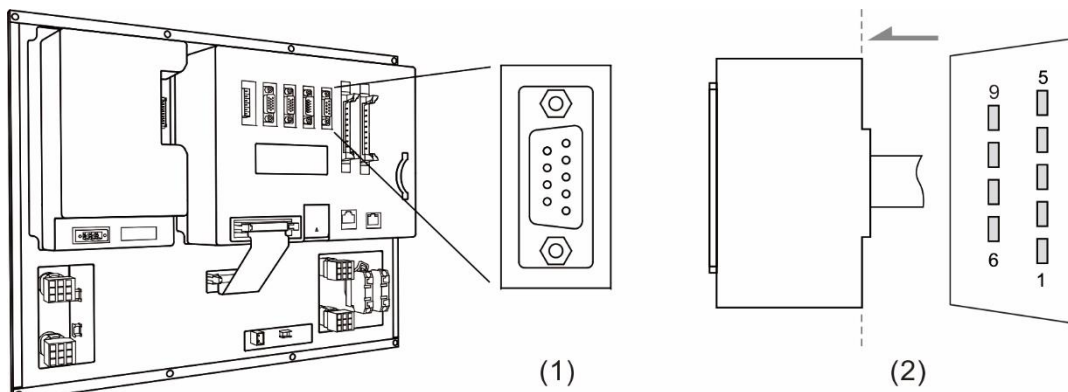

(1) RS-485 connector (female); (2) RS-485 connector (male)

Model	Symbol	Pin No.	Function description
NC3_ _	RS-485	1	D+
		6	D-

Pin assignment for NC2 series models

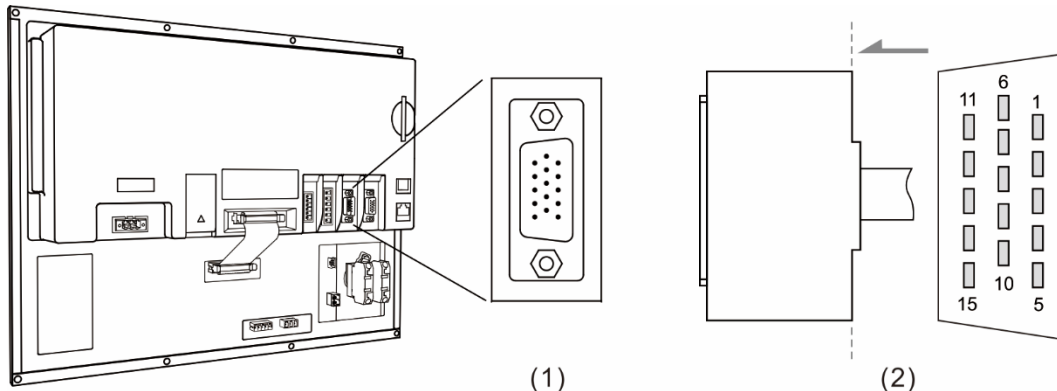

(1) RS-485 connector (female); (2) RS-485 connector (male)

Model	Symbol	Pin No.	Function description
NC2_ _	SPINDLE	2	D+
		3	D-



3

Pin assignment for OPENCNC series models

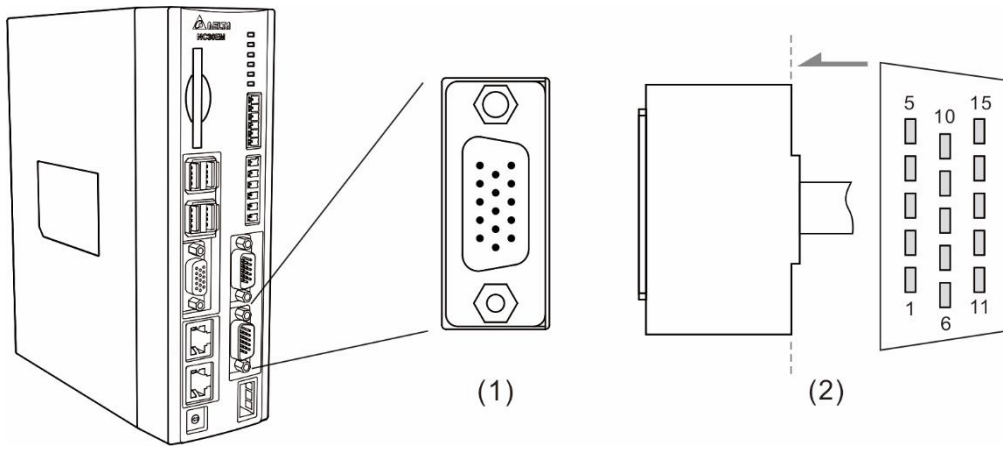

(1) RS-485 connector (female); (2) RS-485 connector (male)

Model	Symbol	Pin No.	Function description
NC30E_	SPINDLE	2	D+
		3	D-

### 3.1.5 Wiring for Axis 1 - 4 input connector

The NC controller provides input points of hardware positive / negative limits and home signal for the servo axes; there are 12 input points in the Axis 1 - 4 terminal block. The COM terminals can connect to +24 V<sub>DC</sub> or 0V, and the corresponding input point signal must be changed to 0V or +24 V<sub>DC</sub>.

Pin assignment for NC3 series models

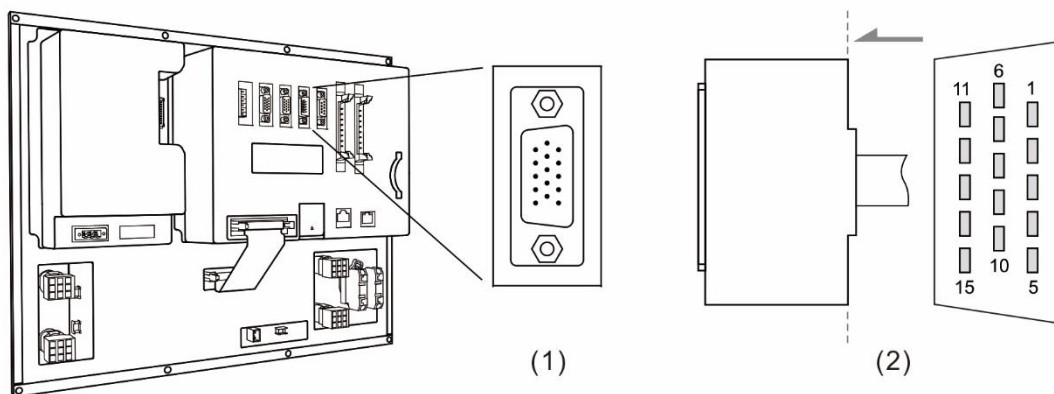

(1) Axis 1 - 4 input connector (female); (2) Axis 1 - 4 input connector (male)

Model	Symbol	Pin No.	Function description	
NC3_ _	Axis 1 - 4	1	OT0+	Axis 1 positive limit
		2	OT0-	Axis 1 negative limit
		3	DOG0	Axis 1 home signal
		4	OT1+	Axis 2 positive limit
		5	OT1-	Axis 2 negative limit
		6	DOG1	Axis 2 home signal
		7	OT2+	Axis 3 positive limit
		8	OT2-	Axis 3 negative limit
		9	DOG2	Axis 3 home signal
		10	OT3+	Axis 4 positive limit
		11	OT3-	Axis 4 negative limit
		12	DOG3	Axis 4 home signal
		13	COM	COM
		14	COM	COM
		15	COM	COM

# 3

For six-axis servo applications, you can set parameter Pr49 to 1, and then Pin 10 is the Home point (DOG3) of Axis 4, Pin 11 is the Home point (DOG4) of Axis 5, and Pin 12 is the Home point (DOG5) of Axis 6.

### Descriptions of related special M relays

Pin P1 - P3	Positive limit, negative limit, and home point input of the 1 <sup>st</sup> axis (M2144, M2145, M2146)
Pin P4 - P6	Positive limit, negative limit, and home point input of the 2 <sup>nd</sup> axis (M2148, M2149, M2150)
Pin P7 - P9	Positive limit, negative limit, and home point input of the 3 <sup>rd</sup> axis (M2152, M2153, M2154)
Pin P10 - P12	Positive limit, negative limit, and home point input of the 4 <sup>th</sup> axis (M2156, M2157, M2158)

The wiring for using voltage as the input signal (allowable voltage: 17 - 32 V<sub>DC</sub>; surge current: under 50 mA) with an external power is as follows:

#### NPN transistor (SINK mode)

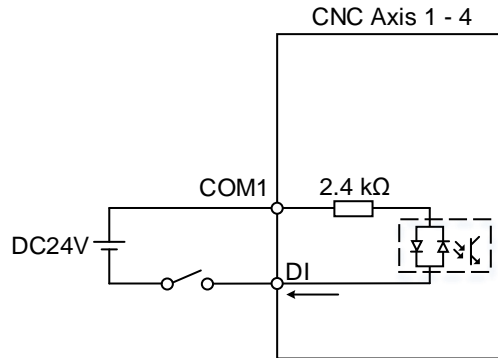

#### PNP transistor (SOURCE mode)

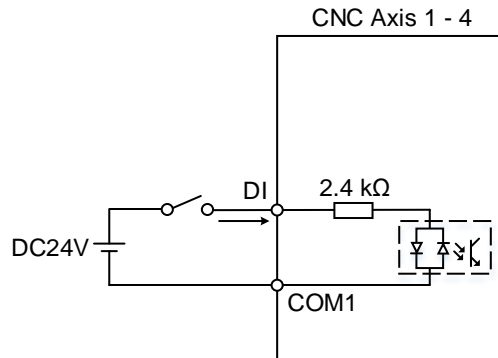

Wiring for the Axis 1 - 4 connector and the NC-EXM-S01 inverter card

3

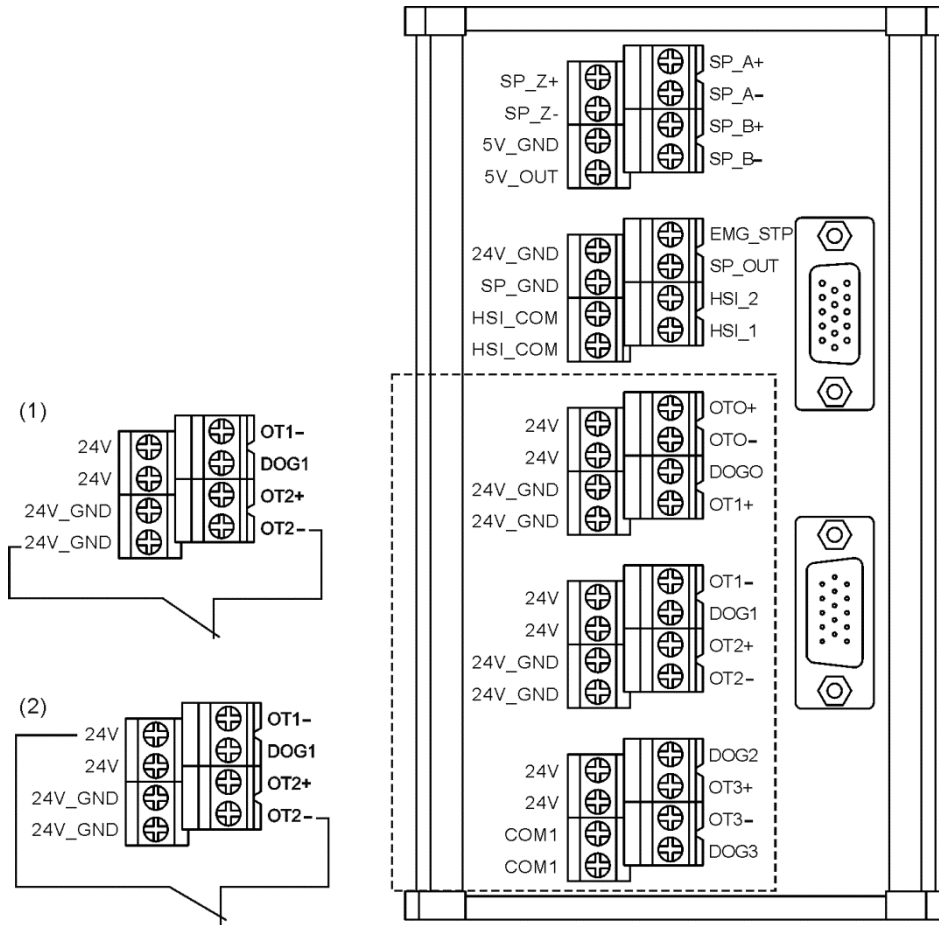

(1) DI wiring method when 0V is connected to COM1;

(2) DI wiring method when +24 V<sub>DC</sub> is connected to COM1

3

### 3.1.6 Wiring for spindle feedback input connector

The NC series controller has one set of spindle feedback input.

Pin assignment for NC3 series models

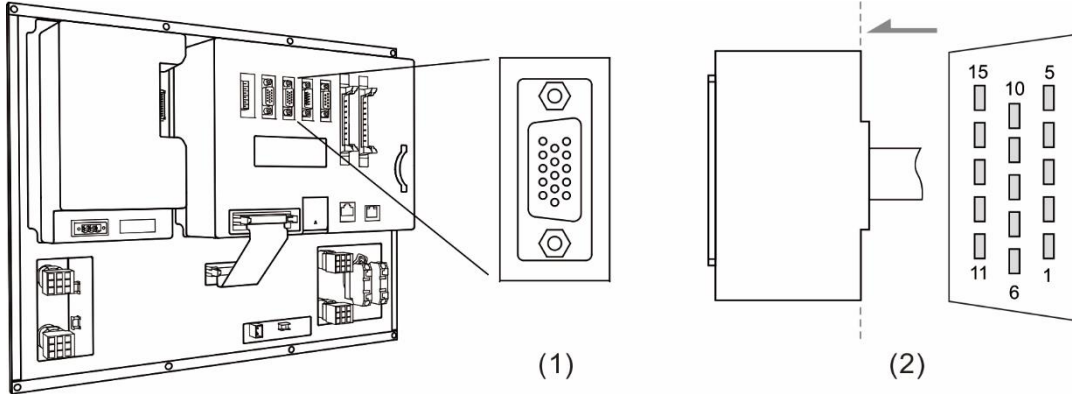

(1) Spindle feedback input connector (female); (2) Spindle feedback input connector (male)

Pin assignment for NC2 series models

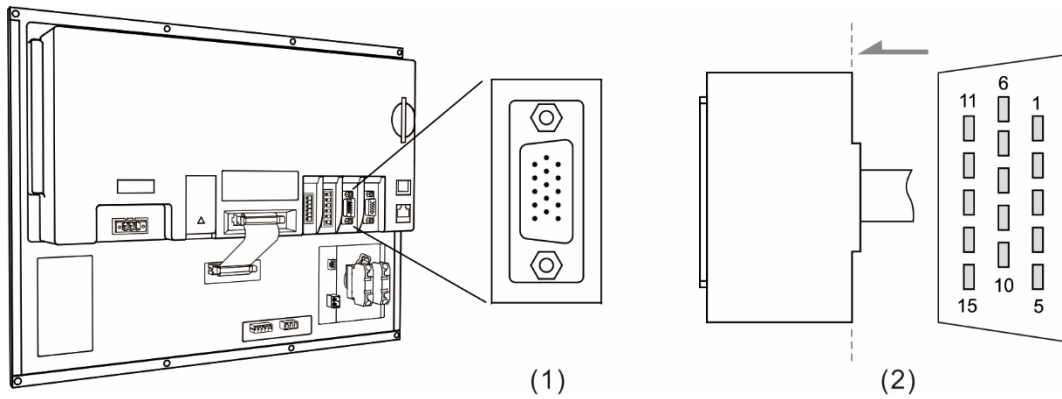

(1) Spindle feedback input connector (female); (2) Spindle feedback input connector (male)

Pin assignment for OPENCNC series models

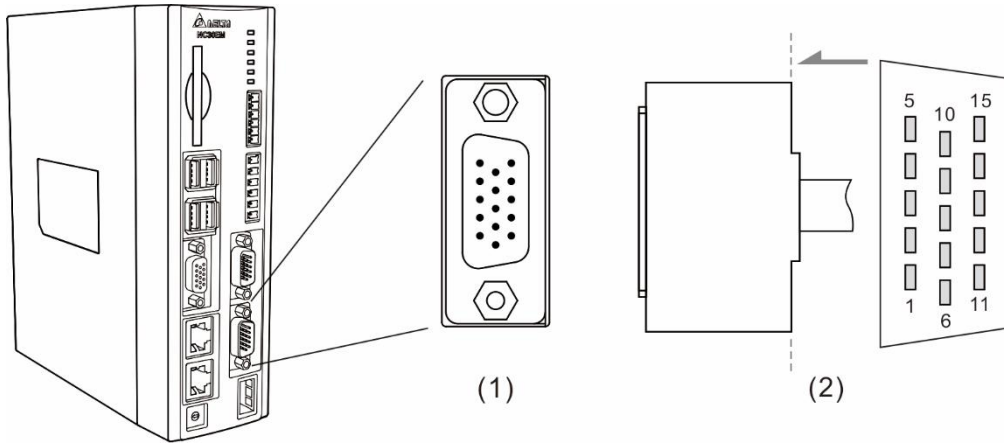

(1) Spindle feedback input connector (female); (2) Spindle feedback input connector (male)

Model	Symbol	Pin No.	Function description	
ALL	SPINDLE	8	SP_A+	Spindle encoder A+ pulse input
		9	SP_A-	Spindle encoder A- pulse input
		10	DC +5V_OUT	Spindle encoder power output (+5 V <sub>DC</sub> )
		11	SP_B+	Spindle encoder B+ pulse input
		12	SP_B-	Spindle encoder B- pulse input
		13	SP_Z+	Spindle encoder Z+ pulse input
		14	SP_Z-	Spindle encoder Z- pulse input
		15	GND	Spindle encoder power output (0V)

3

### 3.1.7 Wiring for spindle analog output connector

The NC series controller has one set of spindle analog output for controlling the spindle speed.

Pin assignment for NC3 series models

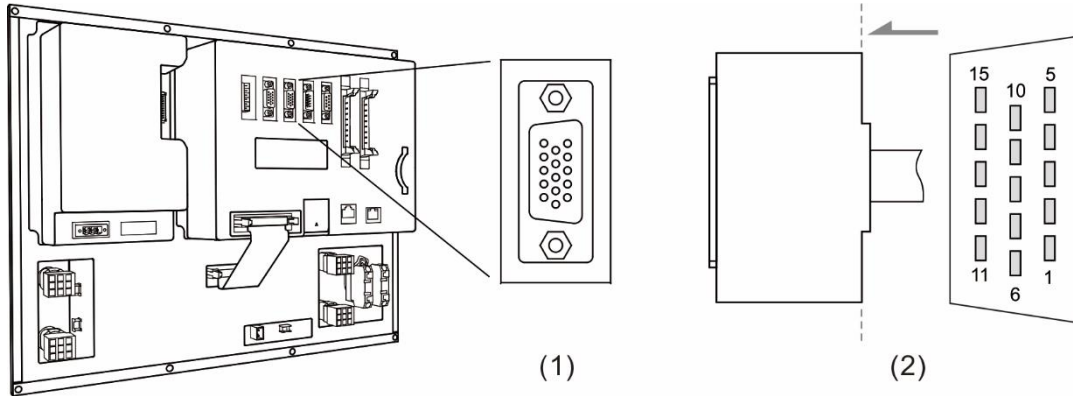

(1) Spindle analog output connector (female); (2) Spindle analog output connector (male)

Pin assignment for NC2 series models

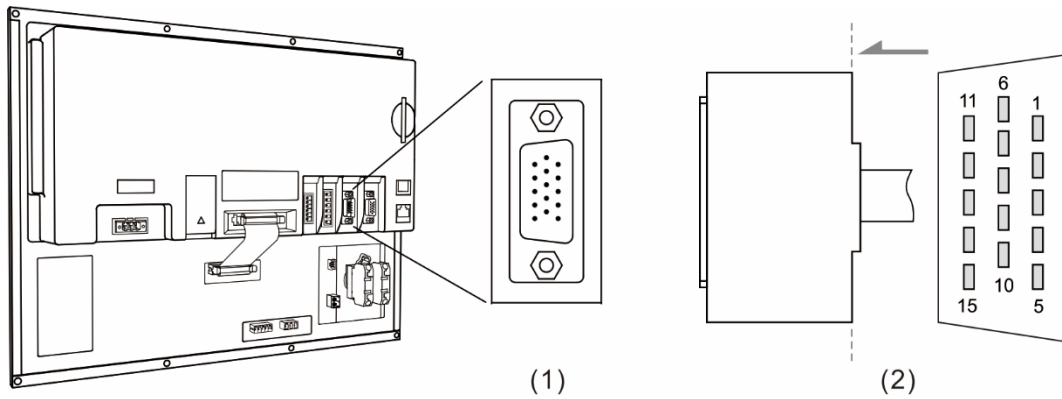

(1) Spindle analog output connector (female); (2) Spindle analog output connector (male)

Pin assignment for OPENCNC series models

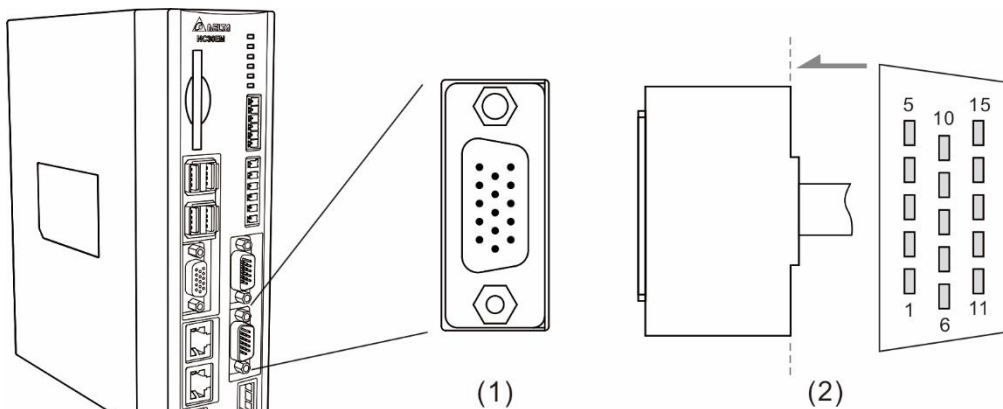

(1) Spindle analog output connector (female); (2) Spindle analog output connector (male)

Model	Symbol	Pin No.	Function description
ALL	SPINDLE	4	SP_OUT Spindle analog output
		5	SP_GND Ground for spindle analog output signal

Settings for analog spindle are as follows:

1. Pr399 setting

Description	Servo control	Analog control
Spindle function 0: off; 1: on	1	1
Closed-loop control flag 0: off 1: on (feedback encoder is required)	1	0 or 1
Spindle output mode 0: communication (DMCNET); 1: pulse (B series); 2: analog voltage	0	2
Speed control mode 1: PUU	1	1
Spindle encoder magnification 0: 1000 times; 1: 4 times	0	1
Analog spindle speed source 0: command; 1: encoder	0	1
Analog spindle feedback encoder source 0: spindle; 1: motor	0	0
Spindle voltage output mode 0: -10V to +10V 1: 0V to +10V (only effective in open loop control)	0	0 or 1

2. In the channel setting screen (CONFIG), enable SP1 and set its port number to 10.

Note: port number 10 is dedicated for analog output.

3. When analog spindle output is used, the corresponding pins are Pin 4 and Pin 5 of the SPINDLE connector. The analog voltage resolution is 14-bit.

Pr399 [Spindle output voltage] = 0; -10V to +10V voltage control.

Output voltage value	Corresponding rotation speed
+10 V <sub>DC</sub>	Maximum rotation speed (forward)
0 V <sub>DC</sub>	Zero speed
-10 V <sub>DC</sub>	Maximum rotation speed (reverse)

Note: this control mode can be used for closed loop and open loop controls, and can satisfy the tapping and threading functions.

Pr399 [Spindle output voltage] = 1; 0V to +10V voltage control.

Output voltage value	Corresponding rotation speed
+10 V <sub>DC</sub>	Maximum rotation speed
0 V <sub>DC</sub>	Zero speed

Note: this control mode is only applicable to open loop control and is unable to control spindle forward / reverse rotation. If there is encoder feedback signal, the threading function can be used but not the tapping function.



3

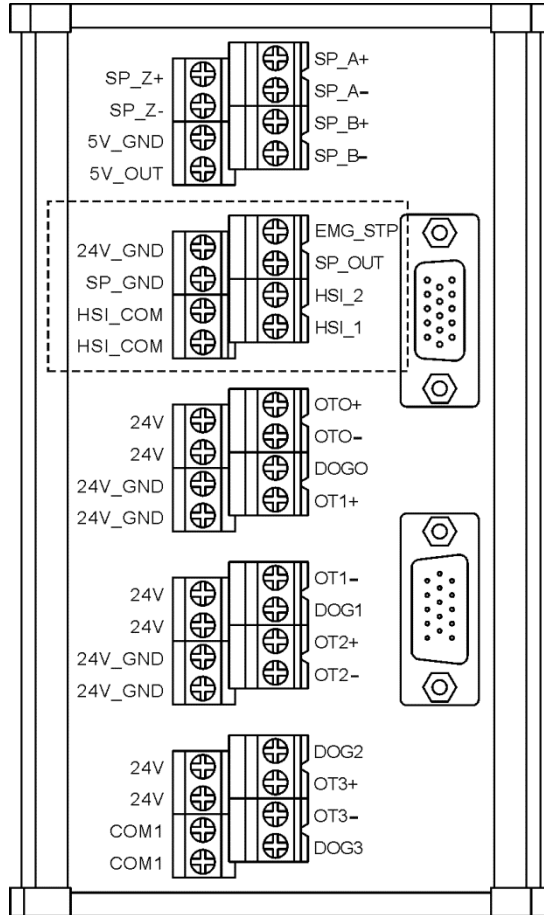
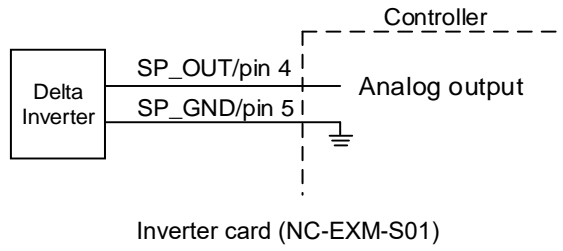

### 3.1.8 Wiring for HSI connector

The NC series controller has two sets of hardware high-speed counter signal input. For the wiring of high-speed counter input (bi-directional coupling), the maximum input bandwidth is up to 5 MHz; voltage: 22 - 26V; permissible current: 8 - 20 mA; surge current: below 50 mA.

The corresponding special M relay for HSI\_1 is M2142, which is also applicable to G31 Skip command.

Settings of relevant parameters:

Parameter address	Parameter name	Function
Pr25	Bit 0	G31 high speed input 1 contact 0: NC; 1: NO
	Bit 1	G31 high speed input 2 contact 0: NC; 1: NO
Pr46	Bit 4	G31 high speed input 1 switch 0: off; 1: on
	Bit 5	G31 high speed input 2 switch 0: off; 1: on
Pr307	Bit 4 - 5	G31 input source 0: off; 1: HSI 1; 2: HSI 2; 3: HSI 1 & 2

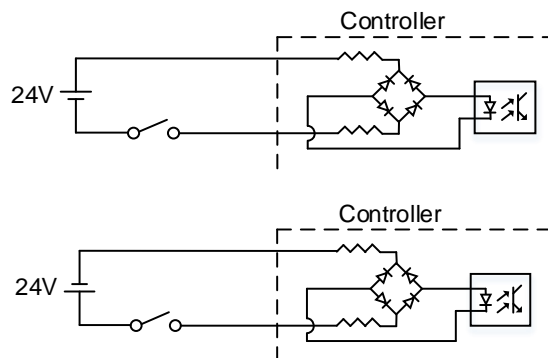

Note: the connection direction of the external power input for HSI does not affect the operation.

3

Pin assignment for NC3 series models

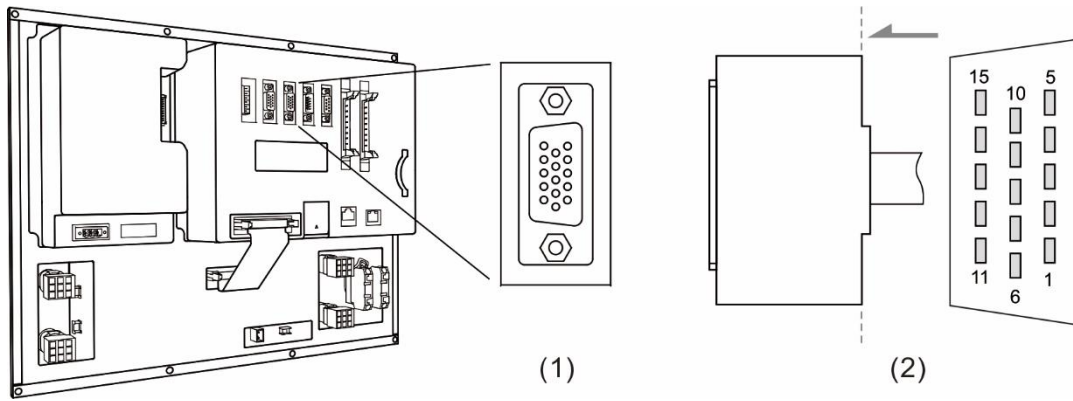

(1) HSI connector (female); (2) HSI connector (male)

Model	Symbol	Pin No.	Function description	
NC3__	SPINDLE	1	HSI_COM	High-speed counter COM; connects to +24 V <sub>DC</sub> or 0V
		2	HSI_1	High-speed counter input 1 (10 mA)
		3	HSI_2	High-speed counter input 2 (10 mA)

Pin assignment for NC2 series models

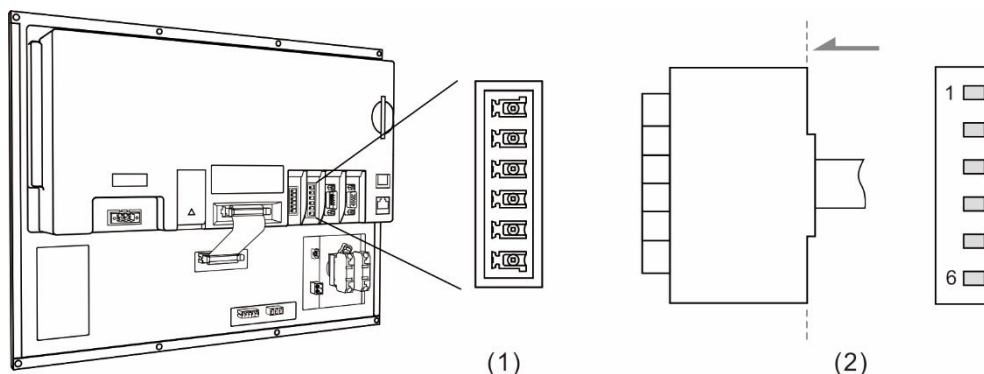

(1) HSI connector (female); (2) HSI connector (male)

Model	Symbol	Pin No.	Function description	
NC2_ _	HSI	3	HSI_1	High-speed counter input 1 (10 mA)
		4	HSI_COM	The high-speed counter COM; connects to +24 V <sub>DC</sub> or 0V
		5	HSI_2	High-speed counter input 2 (10 mA)
		6	HSI_COM	The high-speed counter COM; short-circuit P4 and P6

Pin assignment for OPENCNC series models

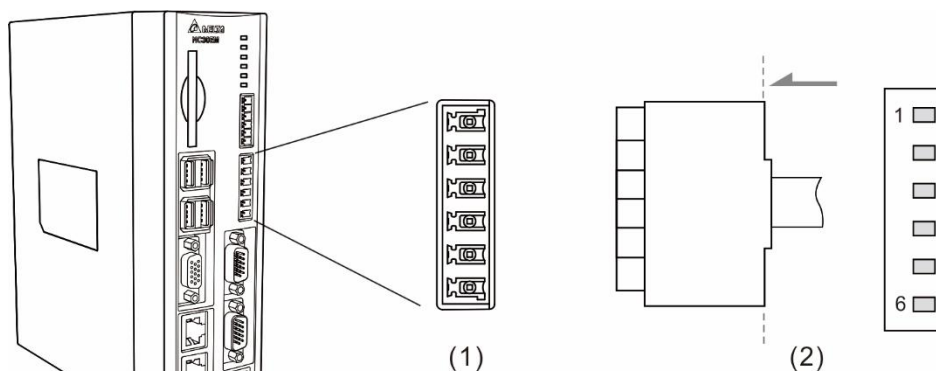

(1) HSI connector (female); (2) HSI connector (male)

Model	Symbol	Pin No.	Function description	
NC30E_	HSI	3	HSI_1	High-speed counter input 1 (10 mA)
		4	GND	GND
		5	HSI_2	High-speed counter input 2 (10 mA)
		6	HSI_COM	High-speed counter COM; connects to +24 V <sub>DC</sub> or 0V

Note: HSI\_1 and HSI\_2 can output +5V power, so both of them can form a circuit with GND and for immediate use.

# 3

### 3.1.9 Wiring for emergency stop

The NC series controller has one set of emergency stop signal input.

Pin assignment for NC3 series models

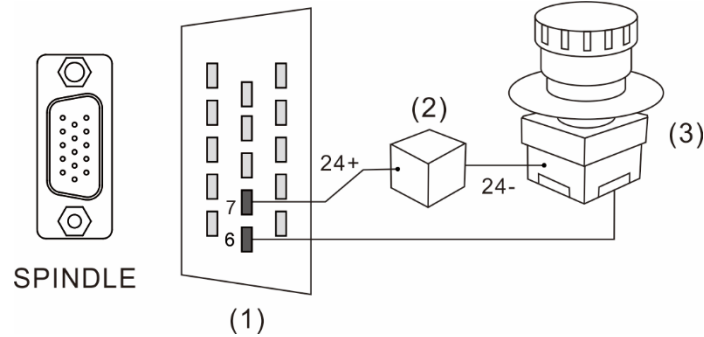

(1) EMG pins; (2) Power supply; (3) Emergency stop button

Model	Symbol	Pin No.	Function description	
NC3__	SPINDLE	6	EMG_GND	Emergency stop input
		7	EMG_IN	+24 V <sub>DC</sub> input

Pin assignment for NC2 series models

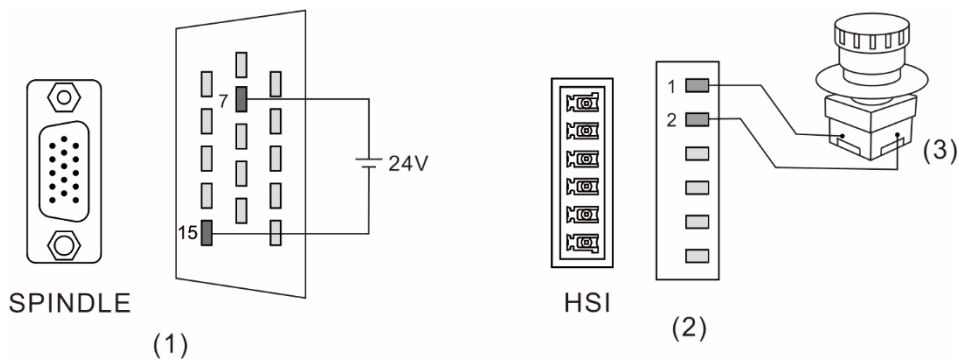

(1) Spindle connector EMG pins; (2) HSI connector EMG pins; (3) Emergency stop button

Model	Symbol	Pin No.	Function description	
NC2__	SPINDLE	7	EMG_IN	Emergency stop power input (+24 V <sub>DC</sub> )
		15	GND	Emergency stop power input (0 V <sub>DC</sub> )
	HSI	1	EMG_IN	Emergency stop input
		2	EMG_GND	Emergency stop input

Pin assignment for OPENCNC series models

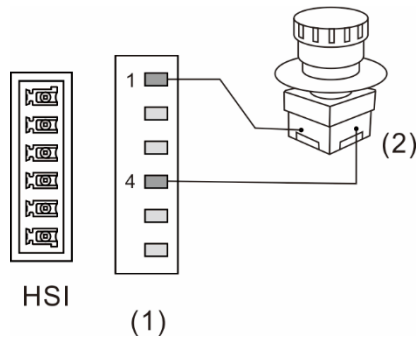

(1) EMG pins; (2) Emergency stop button

Model	Symbol	Pin No.	Function description	
NC30E_	HSI	1	EMG_IN	EMG (+5 V <sub>DC</sub> output)
		4	GND	GND

### 3.1.10 Wiring for MPG connector

The NC series controller has one MPG connector for receiving MPG pulses. This connector supplies +5 V<sub>DC</sub> power which directly supplies power to the MPG.

Pin assignment for NC3 series models

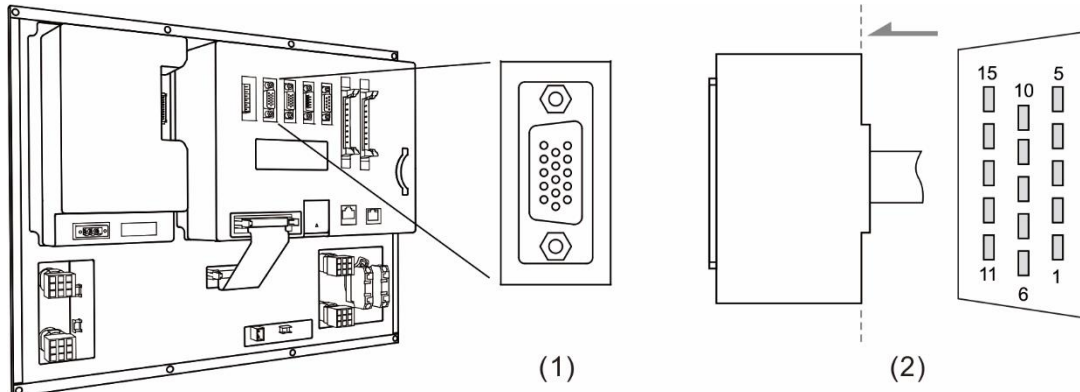

(1) MPG connector (female); (2) MPG connector (male)

Model	Symbol	Pin No.	Function description	
NC3_ _	MPG	1	EXT_24	DI COM point; connects to +24V or 0V
		2	DI_1	X28; recommended for the X axis selection input
		3	DI_2	X29; recommended for the Y axis selection input
		4	DI_3	X30; recommended for the Z axis selection input
		5	DI_4	X31; recommended for magnification x1 selection input
		6	DI_5	X32; recommended for magnification x10 selection input
		7	DI_6	X33; recommended for magnification x100 selection input
		8	DI_7	X34; recommended for the A axis selection input*
		9	DI_8	X35; recommended for the B axis selection input*
		10	5V_OUT	5 V <sub>DC</sub> _OUT
		11	XA+	XA+
		12	XA-	XA-
		13	XB+	XB+
		14	XB-	XB-
		15	5V_GND	5 V <sub>DC</sub> GND

Note: pins 8 and 9 of the NC300 / NC301 / NC310 / NC311 models with the production week of T1751 in the serial number are reserved and are short-circuited internally with Pin 15.

Pin assignment for NC2 series models

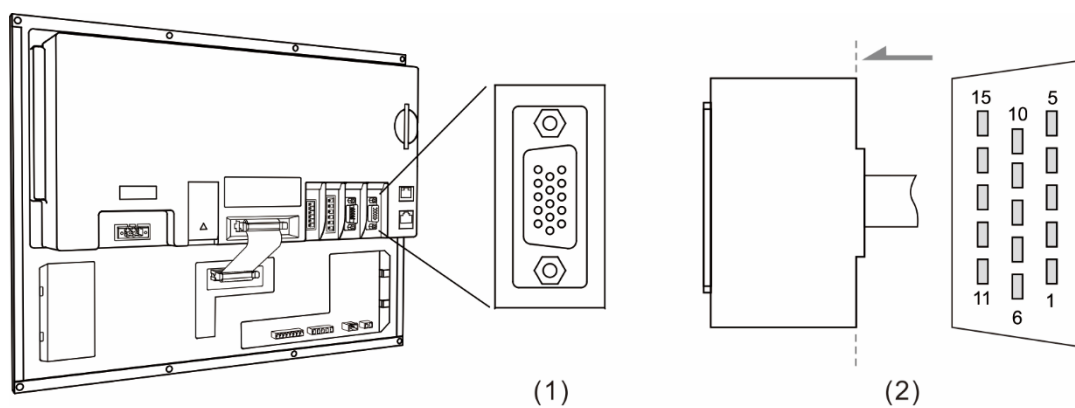

(1) MPG connector (female); (2) MPG connector (male)

Model	Symbol	Pin No.	Function description	
NC2__	MPG	1	EXT_24	DI COM point; connects to +24V or 0V
		2	DI_1	X28; recommended for the X axis selection input
		3	DI_2	X29; recommended for the Y axis selection input
		4	DI_3	X30; recommended for the Z axis selection input
		5	DI_4	X31; recommended for magnification x1 selection input
		6	DI_5	X32; recommended for magnification x10 selection input
		7	DI_6	X33; recommended for magnification x100 selection input
		8	DI_7	X26; recommended for the A axis selection input
		9	DO_8	Y27
		10	5V_OUT	5 V <sub>DC</sub> _OUT
		11	XA+	XA+
		12	XA-	XA-
		13	XB+	XB+
		14	XB-	XB-
		15	5V_GND	5 V <sub>DC</sub> _GND



3

Pin assignment for OPENCNC series models

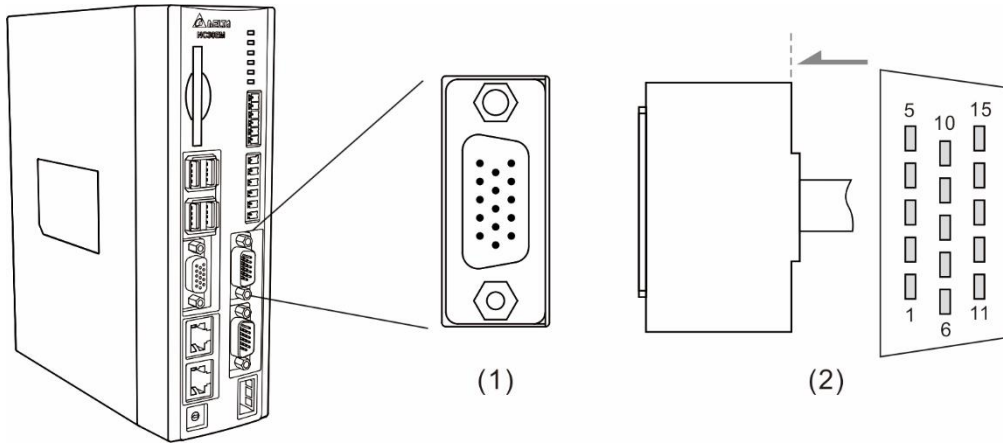

(1) MPG connector (female); (2) MPG connector (male)

Model	Symbol	Pin No.	Function description	
NC30E_	MPG	1	EXT_24	DI COM point; connects to +24V or 0V
		2	DI_1	X0
		3	DI_2	X1
		4	DI_3	X2
		5	DI_4	X3
		6	DI_5	X4
		7	DI_6	X5
		8	DI_7	X6
		9	DI_8	X7
		10	5V_OUT	5 V <sub>bc_OUT</sub>
		11	XA+	XA+
		12	XA-	XA-
		13	XB+	XB+
		14	XB-	XB-
		15	5V_GND	5 V <sub>bc_GND</sub>

The signal type determines the wiring for MPG, including single-ended type (EHDW-BA6SI) and differential type (EHDW-BE6SI).

Single-ended MPG pulse signal wiring diagram

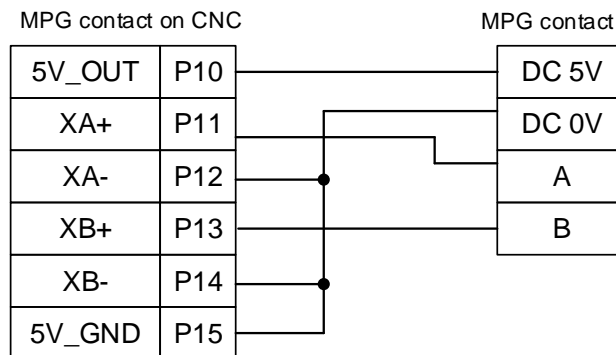
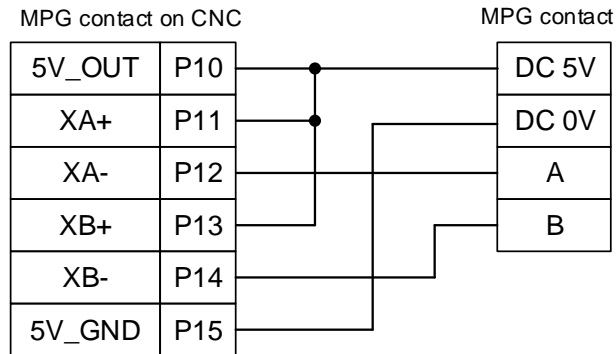

Differential type MPG pulse signal wiring diagram

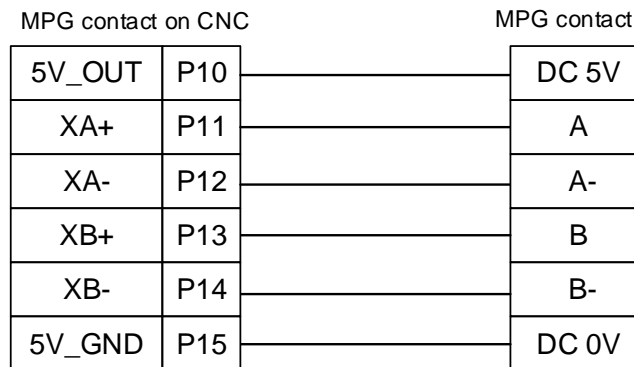

# 3

## MPG switch wiring diagram

- The 5V power is supplied from the MPG contact

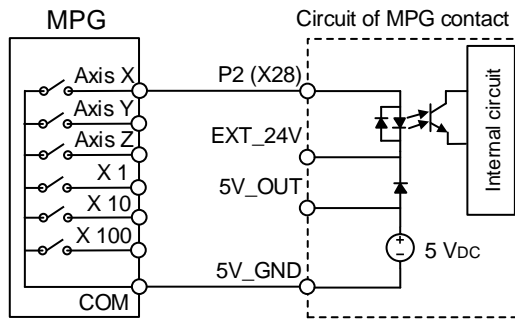

- The 24V power is supplied externally; EXT\_24 can connect to +24V or 0V

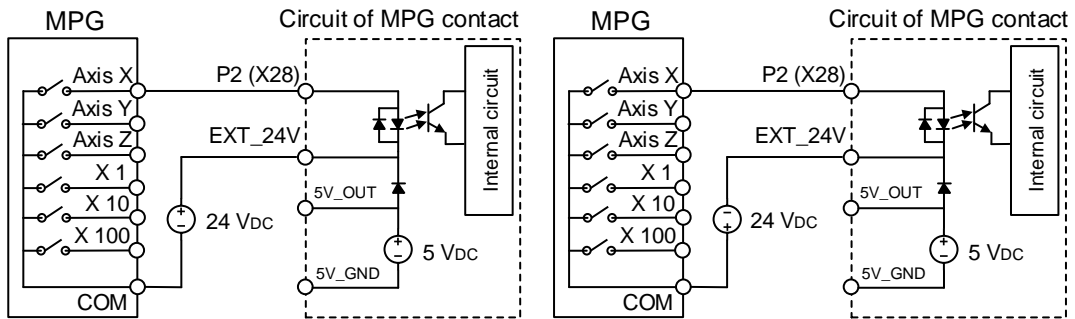

### 3.1.11 Wiring for remote I/O connector

After the remote I/O module is connected to the NC series controller, there are 256 output and 256 input points available. For every additional station, its I/O address will offset backwards for 32 points. Up to 8 modules can be connected simultaneously, providing a maximum of 256 output points and 256 input points.

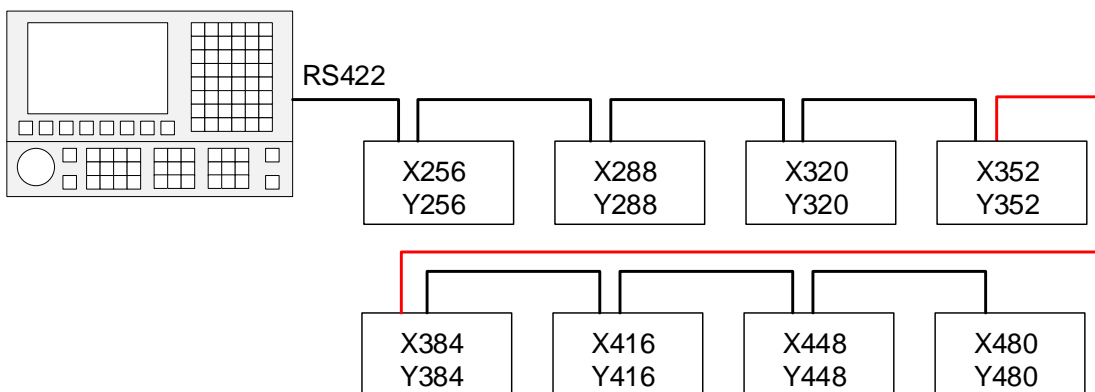

Remote I/O connector and pin definitions

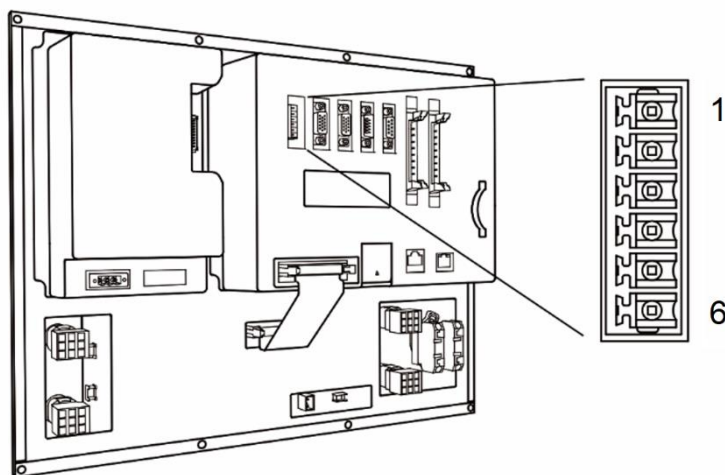

Pin No.	Function description
1	TX+
2	TX-
3	RX-
4	RX+
5	GND
6	SHIELD

3

Wiring diagram for remote I/O connector

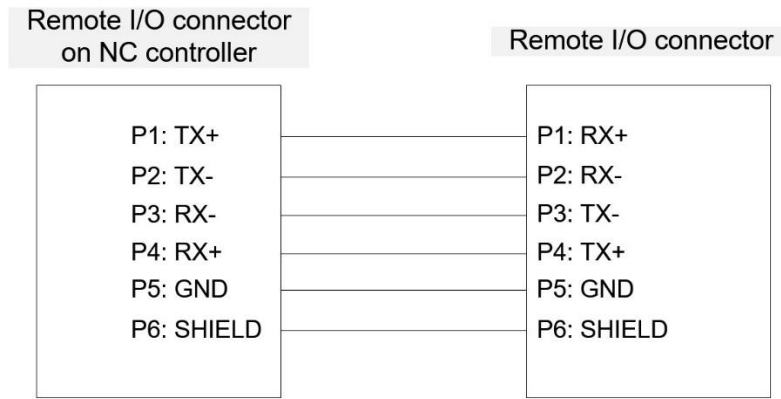

The remote I/O module is mainly divided into two types: optical coupling type and relay type; the definitions of their model names are as follows:

**NC - EIO - T 32 32**  
 (1)            (2)            (3) (4)    (5) (6)

(1) Series name

(2) Product name

(3) Type:

T: optical coupling type (allowable current: under 50 mA; surge current: under 100mA).

R: relay type (according to relay specifications; allowable current: 5A or 16A).

(4) Number of available input points for this model

(5) Number of available output points for this model

(6) Allowable current value for this model:

None: 5A (G2R relay)

A: 16A (G2R relay)

B: 16A (IDEC relay)

The remote I/O modules are as follows:

Model	Description	Remark
NC-EIO-R2010	Relay type IO module with 20 input points and 10 output points	G2R relay Allowable current: 5A
NC-EIO-R2010A	Relay type IO module with 20 input points and 10 output points	G2R relay Allowable current: 16A
NC-EIO-R2010B	Relay type IO module with 20 input points and 10 output points	IDEC relay Allowable current: 16A
NC-EIO-R3216	Relay type IO module with 32 input points and 16 output points	G2R relay Allowable current: 5A
NC-EIO-R3216A	Relay type IO module with 32 input points and 16 output points	G2R relay Allowable current: 16A
NC-EIO-R3216B	Relay type IO module with 32 input points and 16 output points	IDEC relay Allowable current: 16A
NC-EIO-R3232	Relay type IO module with 32 input and 32 output points	Allowable current: 5A
NC-EIO-T3232	Optical coupling type IO module with 32 input and 32 output points	Allowable current: 50mA

# 3

**Precautions for wiring the remote I/O module are as follows:**

- (1) The COM point of the input terminal is used for signal current; DC 24V or 0V power input is strictly prohibited.
- (2) Users can choose whether the input signal is H (PNP) or L (NPN) type with the H / L switch according to the specifications of the external sensor. When H (PNP) is selected, the COM point will provide +24V; when L (NPN) is selected, the COM point will be 0V.

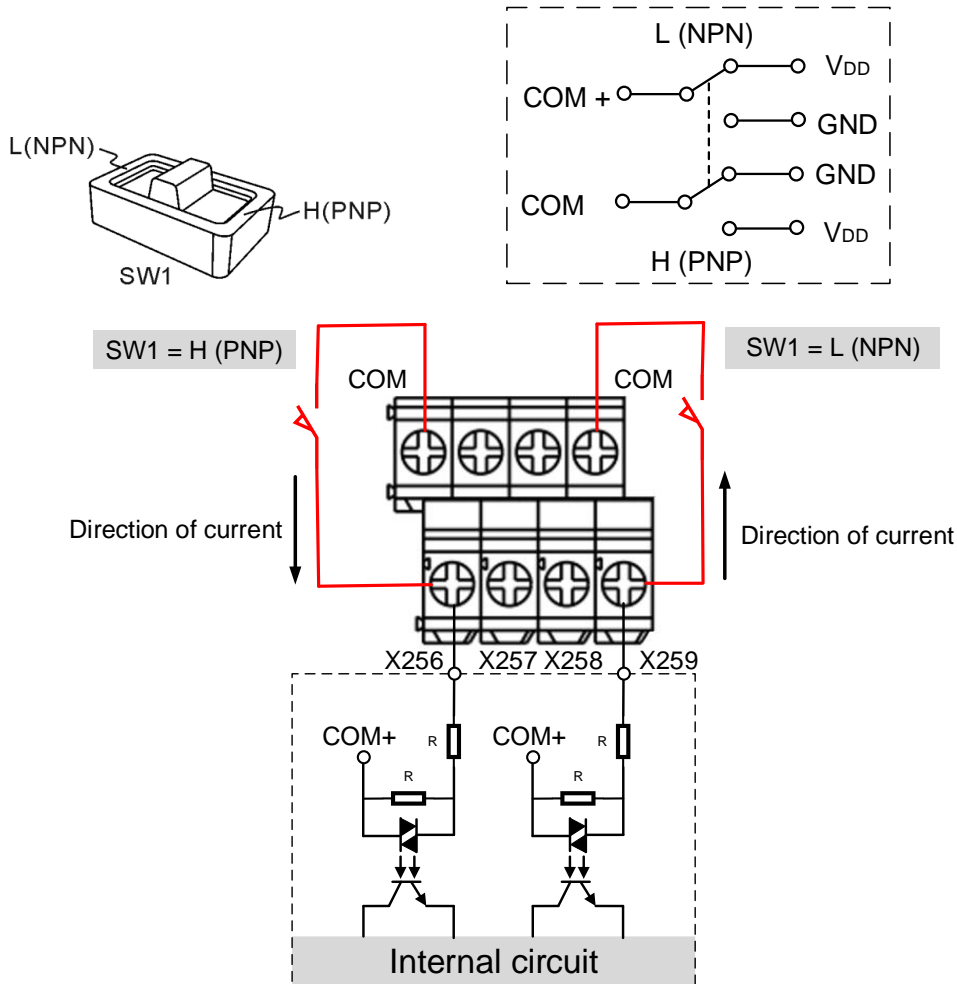

- (3) Up to 8 remote I/O modules can be connected at the same time; the station number of the module can be switched by using the knob on the circuit board. 0 = station 1, 1 = station 2, 2 = station 3 and so on, to a maximum of 7 = station 8.

When the knob of the module is set to 8 (= station 9) and 9 (= station 10), the setting of 8 is regarded as the setting of 0 (= station 1), and the setting of 9 is regarded as the setting of 1 (= station 2). Do not rotate the knob to the same numbers for different modules simultaneously.

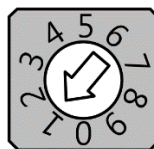

Station number knob

3.1.11.1 NC-EIO-R2010

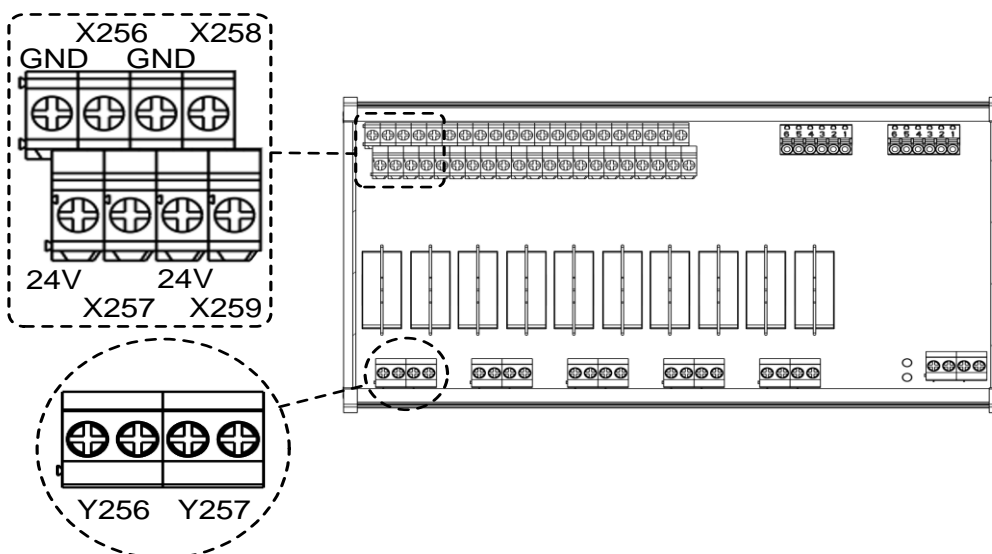

DI wiring example description

Wiring example for the proximity switch of NPN two-wire system:

- (1) Switch the H / L switch to L (NPN), and short-circuit the GND (common specification: blue wire) of the sensor with the GND (0V) of the same power system.
- (2) Simply connect the Vcc (common specification: brown wire) to the input contact.

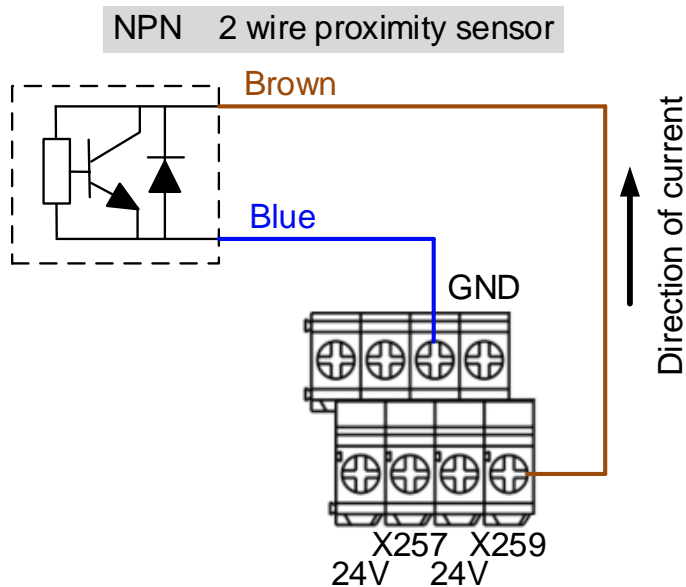



3

Wiring example for the proximity switch of PNP two-wire system:

- (1) Switch the H / L switch to H (PNP), and short-circuit the Vcc (common specification: brown wire) of the sensor with the +24V of the same power system.
- (2) Simply connect the GND (common specification: blue wire) to the input contact.

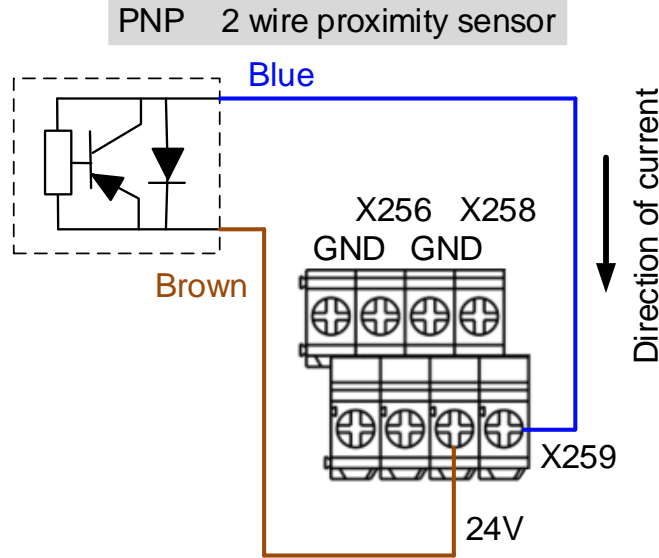

Wiring example for the proximity switch of NPN three-wire system:

- (1) Switch the H / L switch to L (NPN).
- (2) Connect the Vcc (common specification: brown wire) of the sensor to +24V.
- (3) Connect the GND (common specification: blue wire) of the sensor to GND (0V).
- (4) Connect the signal wire (common specification: black wire) of the sensor to the input contact.

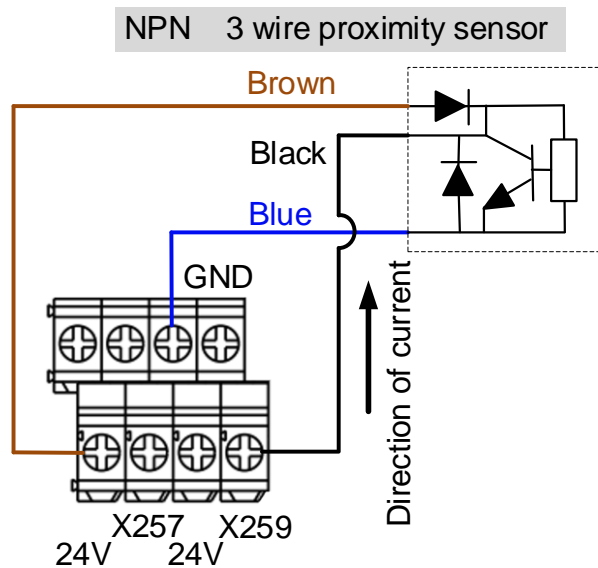

Input wiring example for the proximity switch of PNP three-wire system:

- (1) Switch the H / L switch to H (PNP).
- (2) Connect the Vcc (common specification: brown wire) of the sensor to +24V.
- (3) Connect the GND (common specification: blue wire) of the sensor to GND (0V).
- (4) Connect the signal wire (common specification: black wire) of the sensor to the input contact.

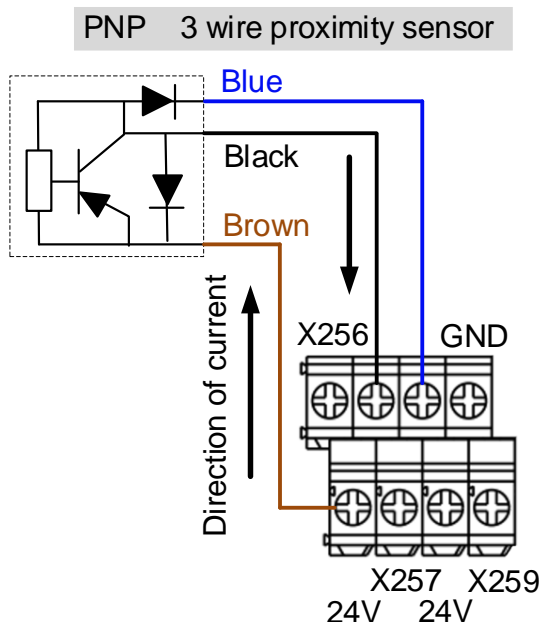

Output wiring example description:

The output contacts of the remote I/O module are in pairs; please use them as dry contacts.

- (1) Connect +24V to one of the output contacts, and the other contact will be DO.
- (2) Connect DO to the Vcc (+) of the external device, and connect the GND (-) of the external device to the 0V of the external power to form a circuit.
- (3) When the controller sets the output contact to on, the circuit is closed and the device will start operating.

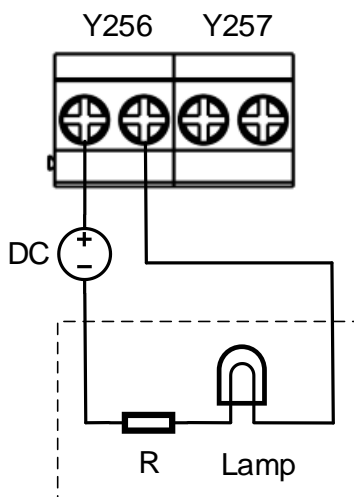

3

3.1.11.2 NC-EIO-R3216

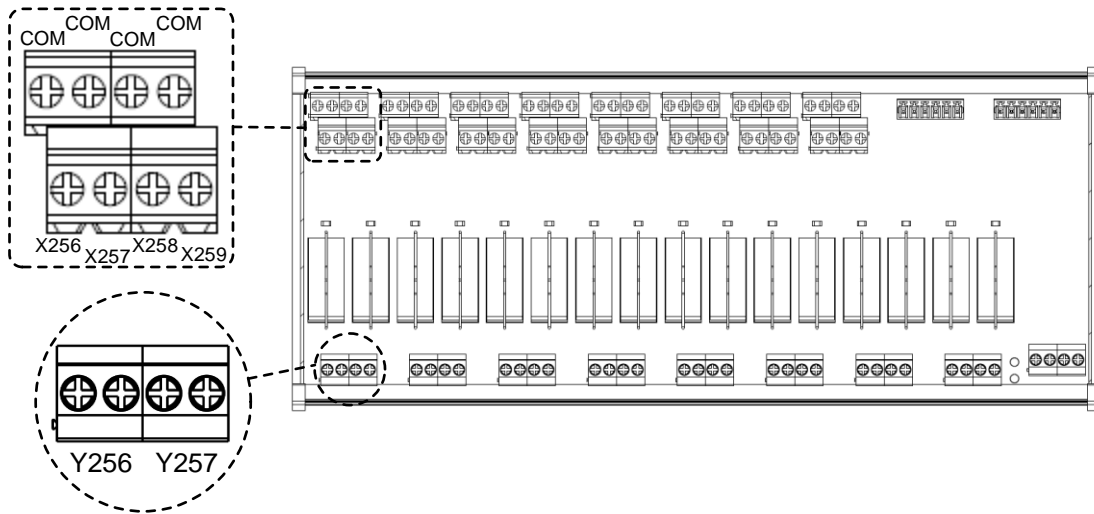

**DI wiring example description:**

Proximity switch of NPN two-wire system:

- (1) Switch the H / L switch to L (NPN), the COM point will provide 0V; connect the GND (common specification: blue wire) of the sensor with COM, or short-circuit the GND of the sensor with the GND (0V) of the same power system.
- (2) Simply connect the Vcc (common specification: brown wire) to the input contact.

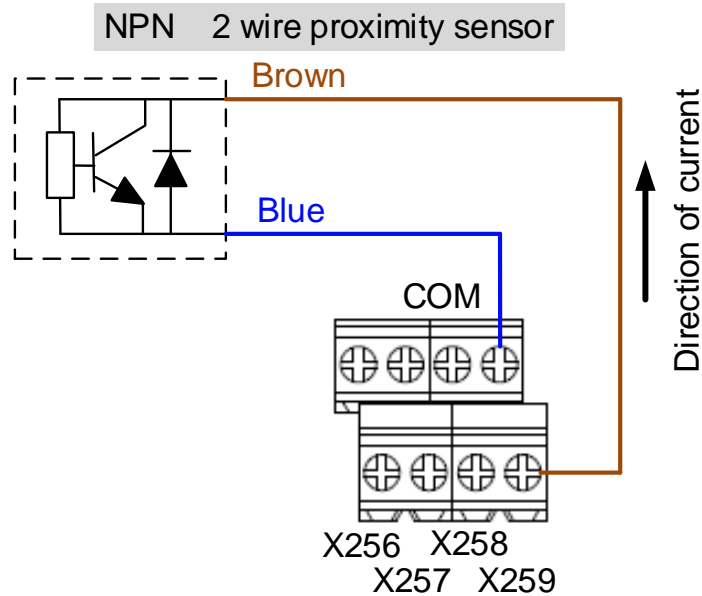

Proximity switch of PNP two-wire system:

- (1) Switch the H / L switch to H (PNP), the COM point will provide +24V; connect the Vcc (common specification: brown wire) of the sensor with COM, or short-circuit the Vcc of the sensor with the +24V of the same power system.
- (2) Simply connect the GND (common specification: blue wire) to the input contact.

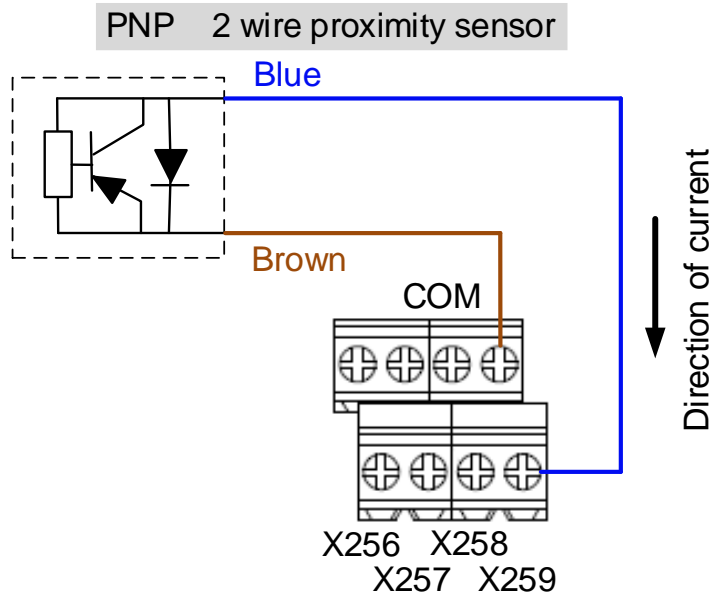

Input wiring example for the proximity switch of NPN three-wire system:

- (1) Switch the H / L switch to L (NPN).
- (2) Connect the Vcc (common specification: brown wire) of the sensor to +24V.
- (3) Connect the GND (common specification: blue wire) of the sensor to COM (0V).
- (4) Connect the signal wire (common specification: black wire) of the sensor to the input contact.

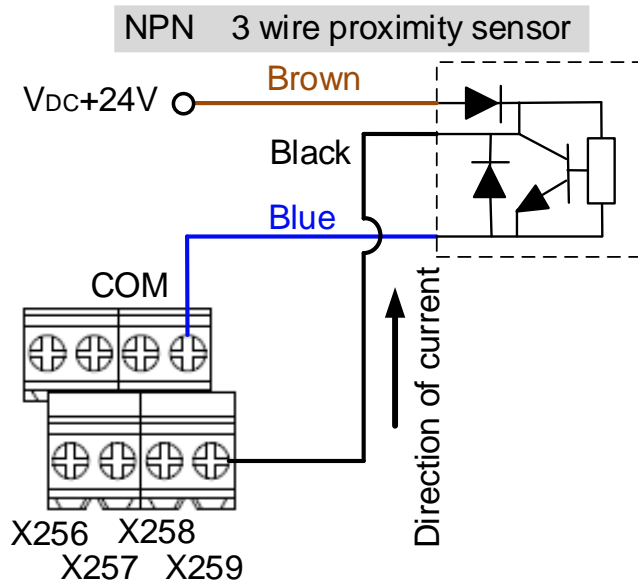

3

Input wiring example for the proximity switch of PNP three-wire system:

- (1) Switch the H / L switch to H (PNP).
- (2) Connect the Vcc (common specification: brown wire) of the sensor to +24V.
- (3) Connect the GND (common specification: blue wire) of the sensor to 0V.
- (4) Connect the signal wire (common specification: black wire) of the sensor to the input contact.

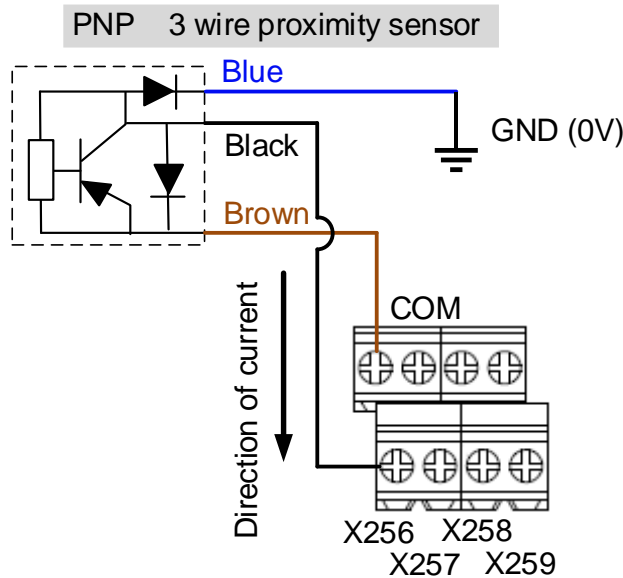

Output wiring example description:

The output contacts of the remote I/O module are in pairs; please use them as dry contacts.

- (1) Connect +24V to one of the output contacts, and the other contact will be DO.
- (2) Connect DO to the Vcc (+) of the external device, and connect the GND (-) of the external device to the 0V of the external power to form a circuit.
- (3) When the controller set the output contact to on, the circuit is closed and the device will start operating.

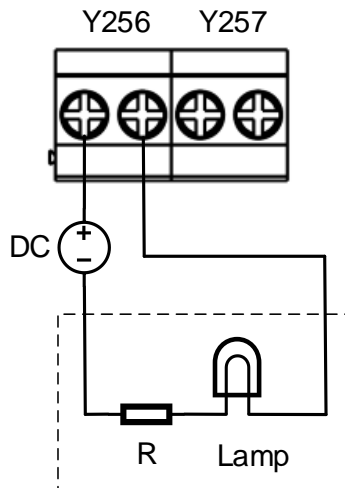

3.1.11.3 NC-EIO-R3232

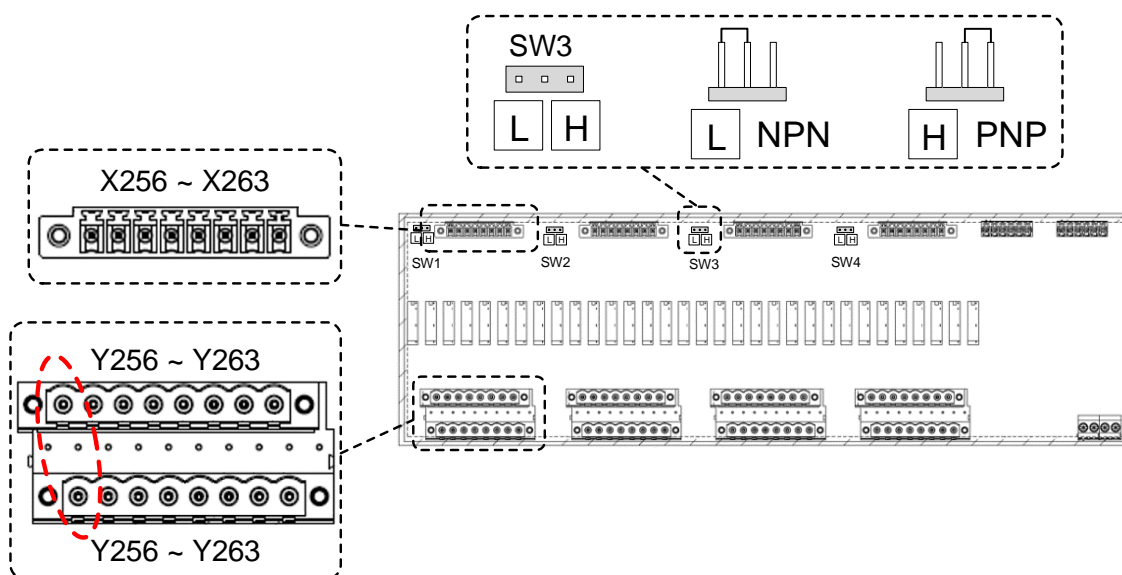

Wiring example for the proximity switch of NPN two-wire system:

- (1) Switch the short circuit jumper to L (NPN), and short-circuit the GND (common specification: blue wire) of the sensor with the GND (0V) of the same power system.
- (2) Simply connect the Vcc (common specification: brown wire) to the input contact.

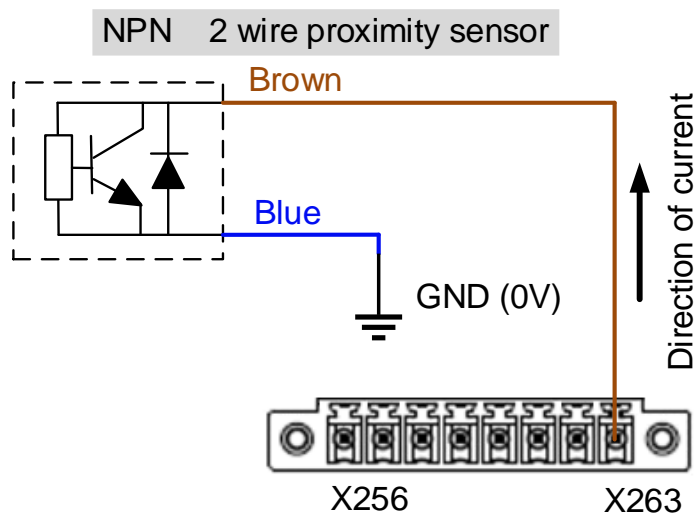

3

Wiring example for the proximity switch of PNP two-wire system:

- (1) Switch the short circuit jumper to H (PNP), and short-circuit the Vcc (common specification: brown wire) of the sensor with the +24V of the same power system.
- (2) Simply connect the GND (common specification: blue wire) to the input contact.

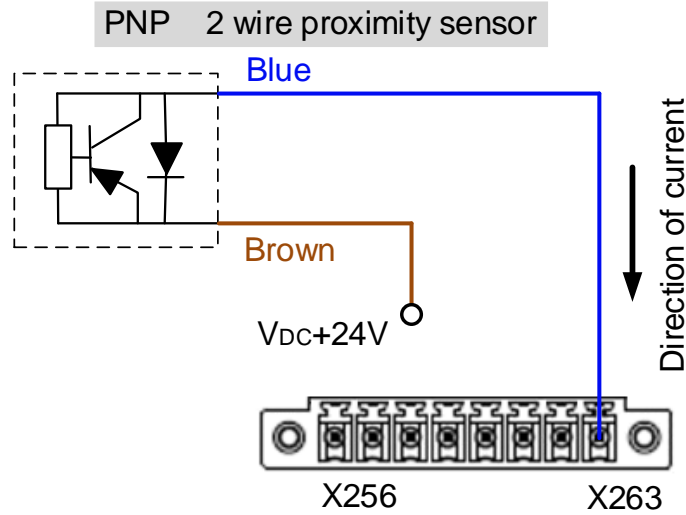

Input wiring example for the proximity switch of NPN three-wire system:

- (1) Switch the short circuit jumper to L (NPN).
- (2) Connect the Vcc (common specification: brown wire) of the sensor to +24V (same power system).
- (3) Connect the GND (common specification: blue wire) of the sensor to 0V (same power system).
- (4) Connect the signal wire (common specification: black wire) of the sensor to the input contact.

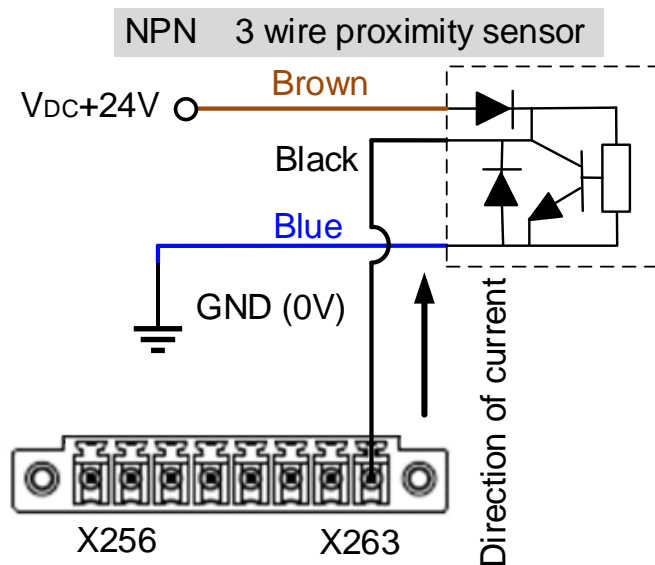

Input wiring example for the proximity switch of PNP three-wire system:

- (1) Switch the short circuit jumper to H (PNP).
- (2) Connect the Vcc (common specification: brown wire) of the sensor to +24V (same power system).
- (3) Connect the GND (common specification: blue wire) of the sensor to 0V (same power system).
- (4) Connect the signal wire (common specification: black wire) of the sensor to the input contact.

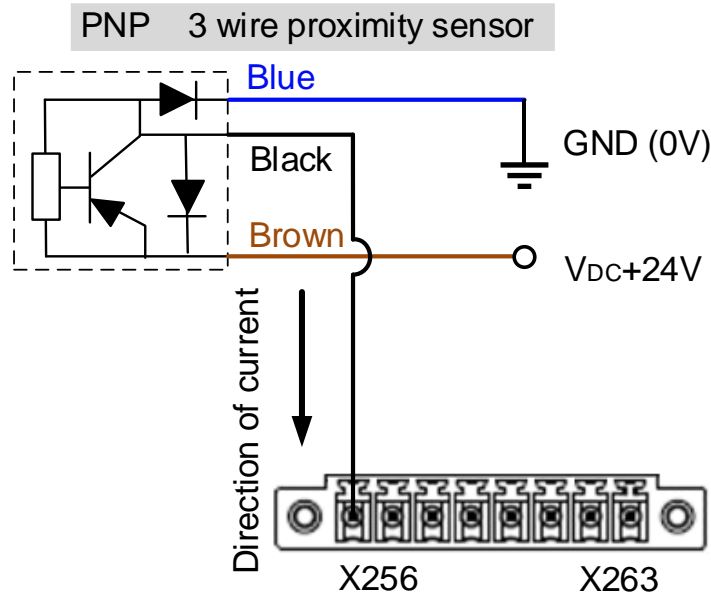

Output wiring example description:

The output contacts of the remote I/O module are in pairs; please use them as dry contacts.

- (1) Connect +24V to one of the output contacts, and the other contact will be DO.
- (2) Connect DO to the Vcc (+) of the external device, and connect the GND (-) of the external device to the 0V of the external power to form a circuit.
- (3) When the controller sets the output contact to on, the circuit is closed and the device will start operating.

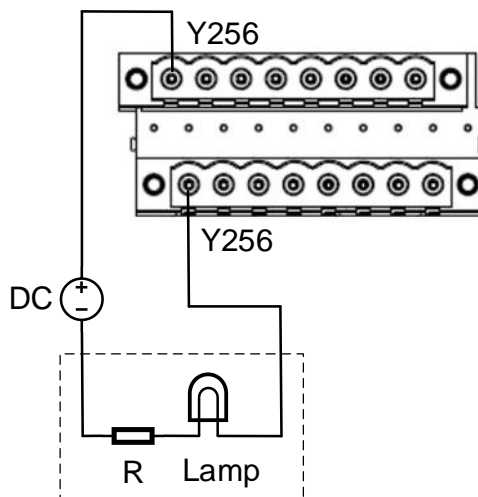



3

3.1.11.4 NC-EIO-T3232

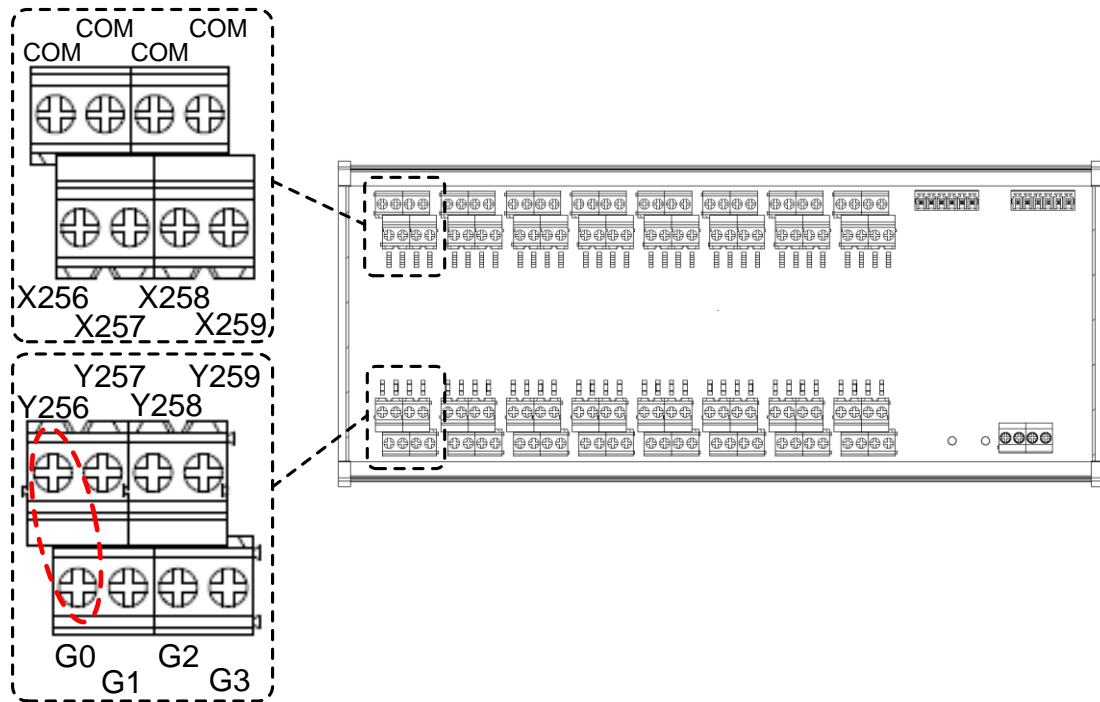

**DI wiring example description:**

Proximity switch of NPN two-wire system:

- (1) Switch the H / L switch to L (NPN), the COM point will provide 0V; connect the GND (common specification: blue wire) of the sensor with COM, or short-circuit the GND of the sensor with the GND (0V) of the same power system.
- (2) Simply connect the Vcc (common specification: brown wire) to the input contact.

**NPN 2 wire proximity sensor**

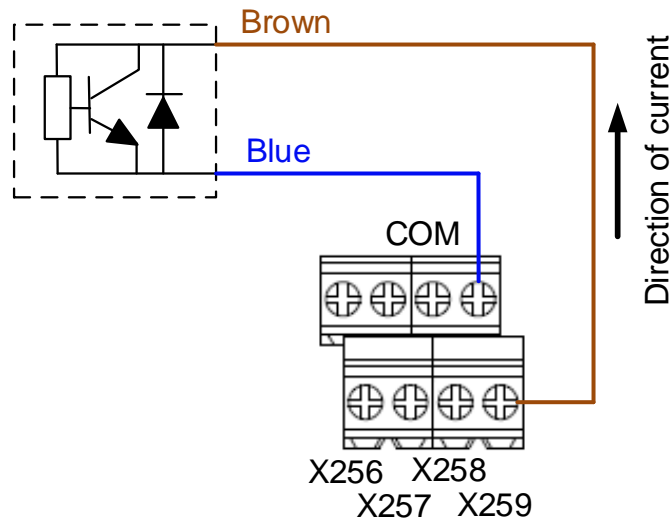

Proximity switch of PNP two-wire system:

- (1) Switch the H / L switch to H (PNP), the COM point will provide +24V; connect the Vcc (common specification: brown wire) of the sensor with COM, or short-circuit the Vcc of the sensor with the +24V of the same power system.
- (2) Simply connect the GND (common specification: blue wire) to the input contact.

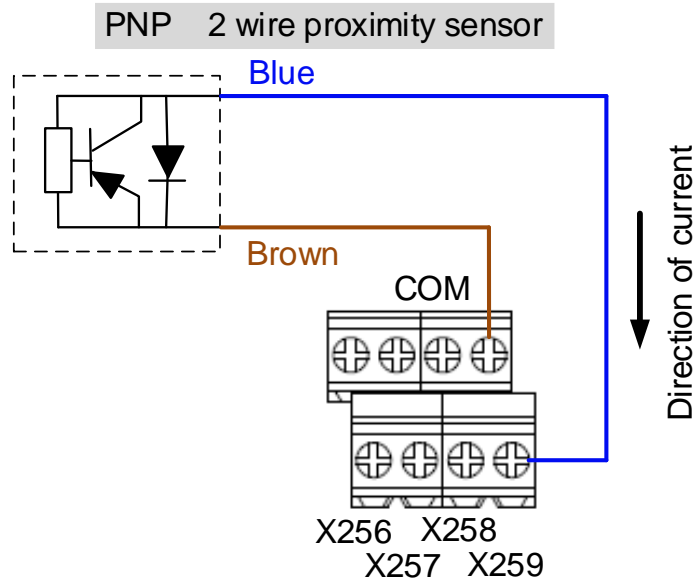

Input wiring example for the proximity switch of NPN three-wire system:

- (1) Switch the H / L switch to L (NPN).
- (2) Connect the Vcc (common specification: brown wire) of the sensor to +24V.
- (3) Connect the GND (common specification: blue wire) of the sensor to 0V.
- (4) Connect the signal wire (common specification: black wire) of the sensor to the input contact.

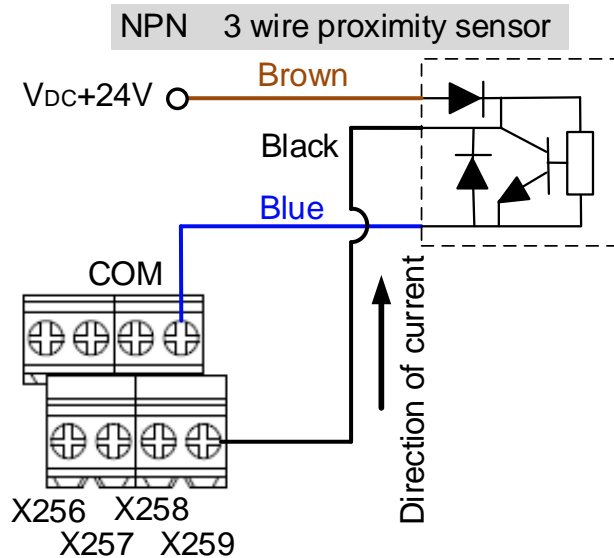

3

Input wiring example for the proximity switch of PNP three-wire system:

- (1) Switch the H / L switch to H (PNP).
- (2) Connect the Vcc (common specification: brown wire) of the sensor to +24V.
- (3) Connect the GND (common specification: blue wire) of the sensor to 0V.
- (4) Connect the signal wire (common specification: black wire) of the sensor to the input contact.

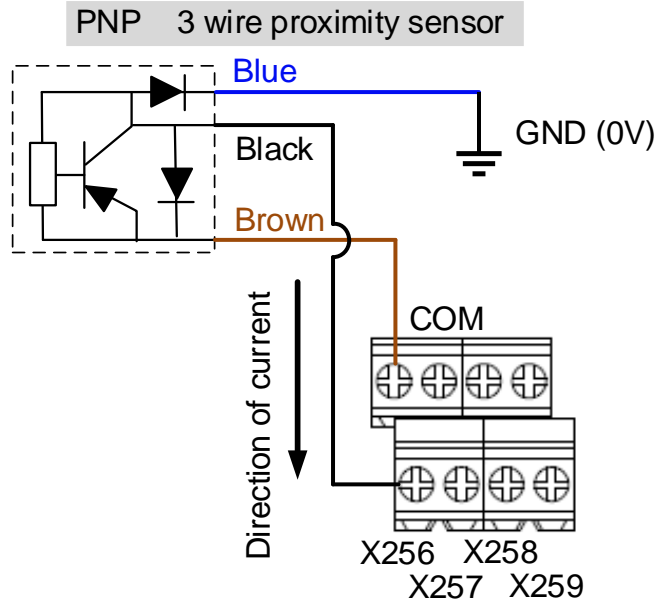

Output wiring example description:

The output contacts of the remote I/O module are in pairs; please use them as dry contacts.

- (1) Connect 0V to one of the output contacts, and the other contact will be DO.
- (2) Connect DO to the GND (-) of the external device, and connect the Vcc (+) of the external device to the +24V of the external power to form a circuit.
- (3) When the controller sets the output contact to on, the circuit is closed and the device will start operating.

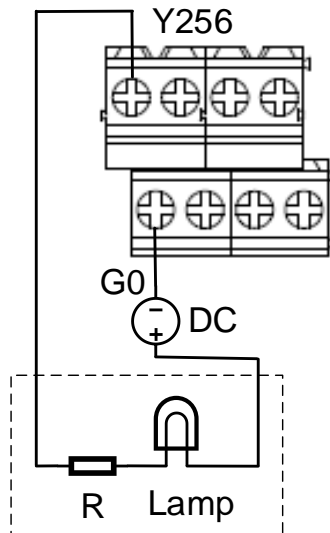

### 3.1.12 Wiring for local I/O connector

For providing a more flexible I/O configuration, some NC series controllers have the local I/O connector.

NC300A-MI-A

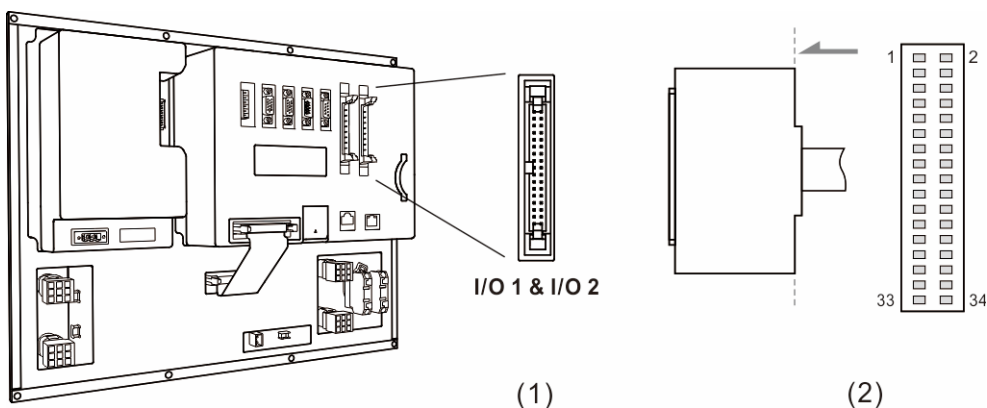

(1) Local I/O connector (female); (2) Local I/O connector (male)

I/O 1			
Pin 1	X0	Pin 2	X1
Pin 3	X2	Pin 4	X3
Pin 5	X4	Pin 6	X5
Pin 7	X6	Pin 8	X7
Pin 9	X8	Pin 10	X9
Pin 11	X10	Pin 12	X11
Pin 13	X12	Pin 14	X13
Pin 15	X14	Pin 16	X15
Pin 17	OUTCOM	Pin 18	COM2
Pin 19	Y0	Pin 20	Y1
Pin 21	Y2	Pin 22	Y3
Pin 23	Y4	Pin 24	Y5
Pin 25	Y6	Pin 26	Y7
Pin 27	Y8	Pin 28	Y9
Pin 29	Y10	Pin 30	Y11
Pin 31	Y12	Pin 32	Y13
Pin 33	Y14	Pin 34	Y15

I/O 2			
Pin 1	X16	Pin 2	X17
Pin 3	X18	Pin 4	X19
Pin 5	X20	Pin 6	X21
Pin 7	X22	Pin 8	X23
Pin 9	X24	Pin 10	X25
Pin 11	X26	Pin 12	X27
Pin 13	NC	Pin 14	NC
Pin 15	NC	Pin 16	NC
Pin 17	OUTCOM	Pin 18	COM3
Pin 19	Y16	Pin 20	Y17
Pin 21	Y18	Pin 22	Y19
Pin 23	Y20	Pin 24	Y21
Pin 25	Y22	Pin 26	Y23
Pin 27	Y24	Pin 28	Y25
Pin 29	Y26	Pin 30	Y27
Pin 31	NC	Pin 32	NC
Pin 33	NC	Pin 34	NC

# 3

NC200A-MI-A

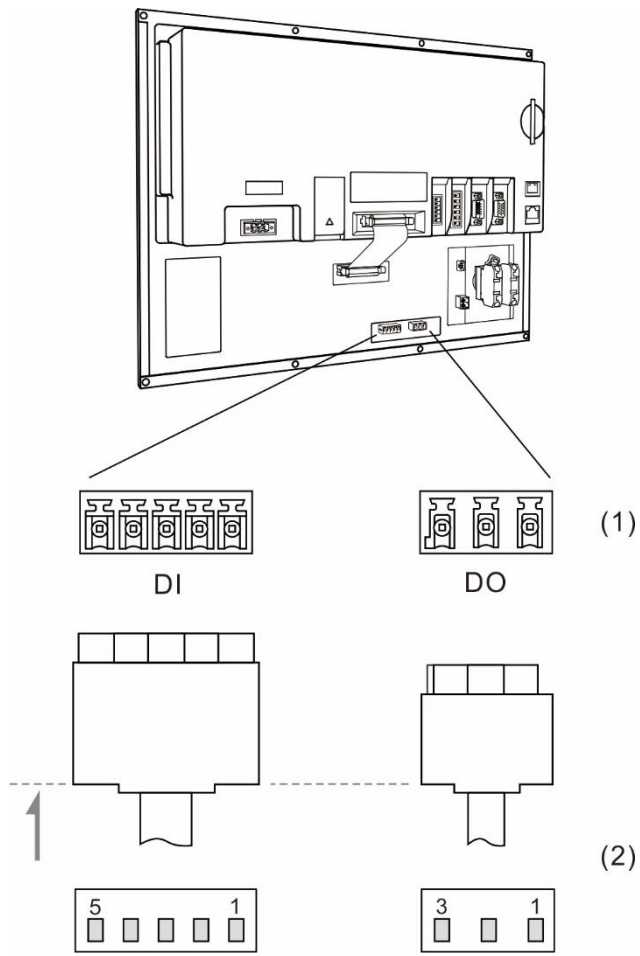

(1) Local I/O connector (female); (2) Local I/O connector (male)

DI			
Pin 1	X112	Pin 2	X113
Pin 3	X114	Pin 4	X115
Pin 5	X116	-	-

DO			
Pin 1	Y112	Pin 2	Y113
Pin 3	Y114	-	-

DI wiring; connect to an external power supply.

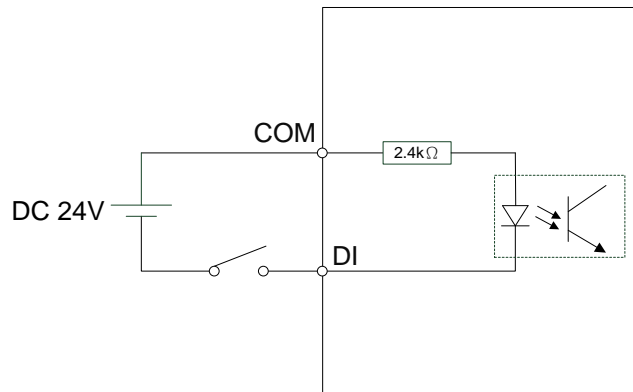

DO wiring; connect to an external power supply.

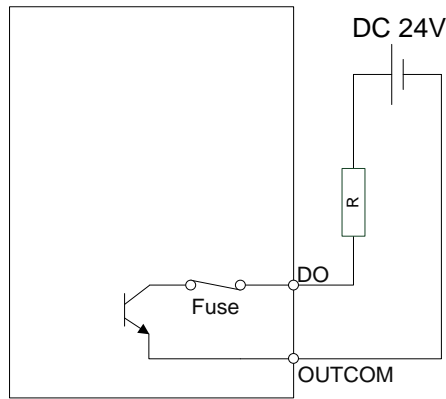

### 3.1.13 Wiring for I/O connector on machine operation panel B of NC300 / NC310 series models

NC300A-MI-A / AE (All-in-one machine)

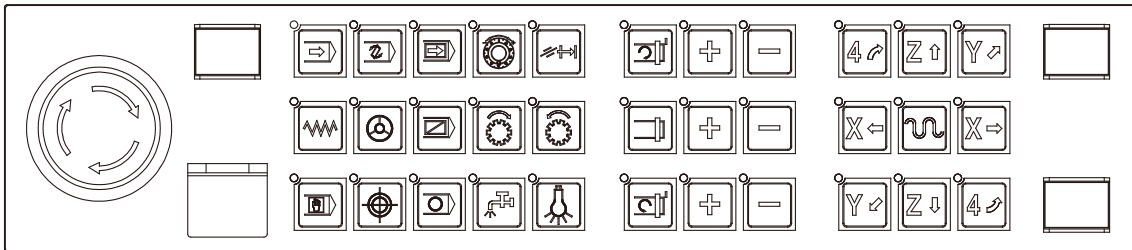

NC-PAN-300AM-F (P) / NC-PAN-310AM-F (P)

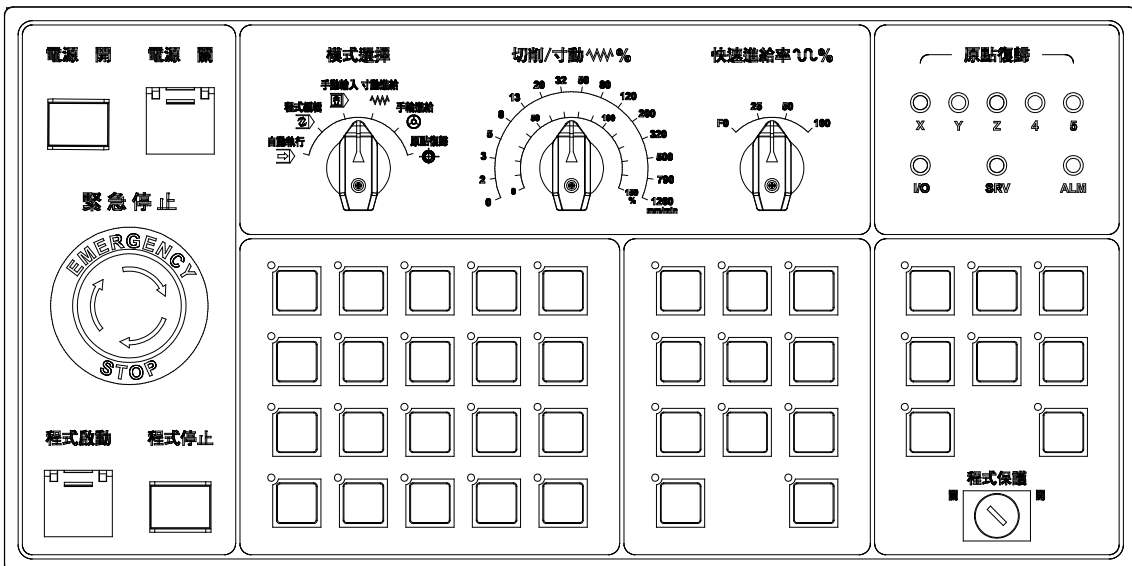

NC-PAN-300AM-F(P)E / NC-PAN-310AM-F(P)E

3

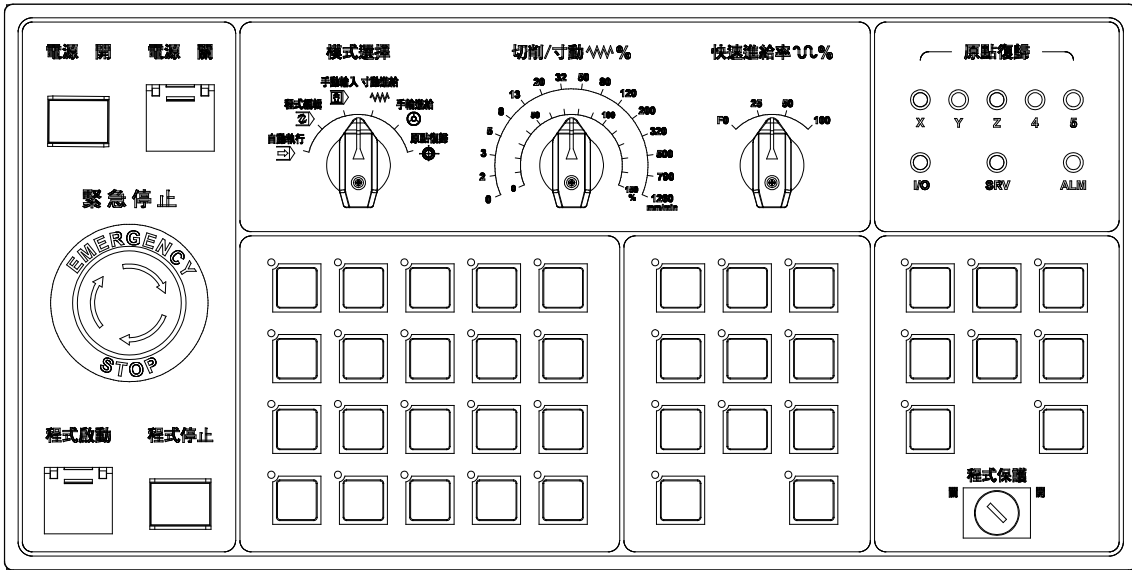

Wiring of the Power On / Power Off switches

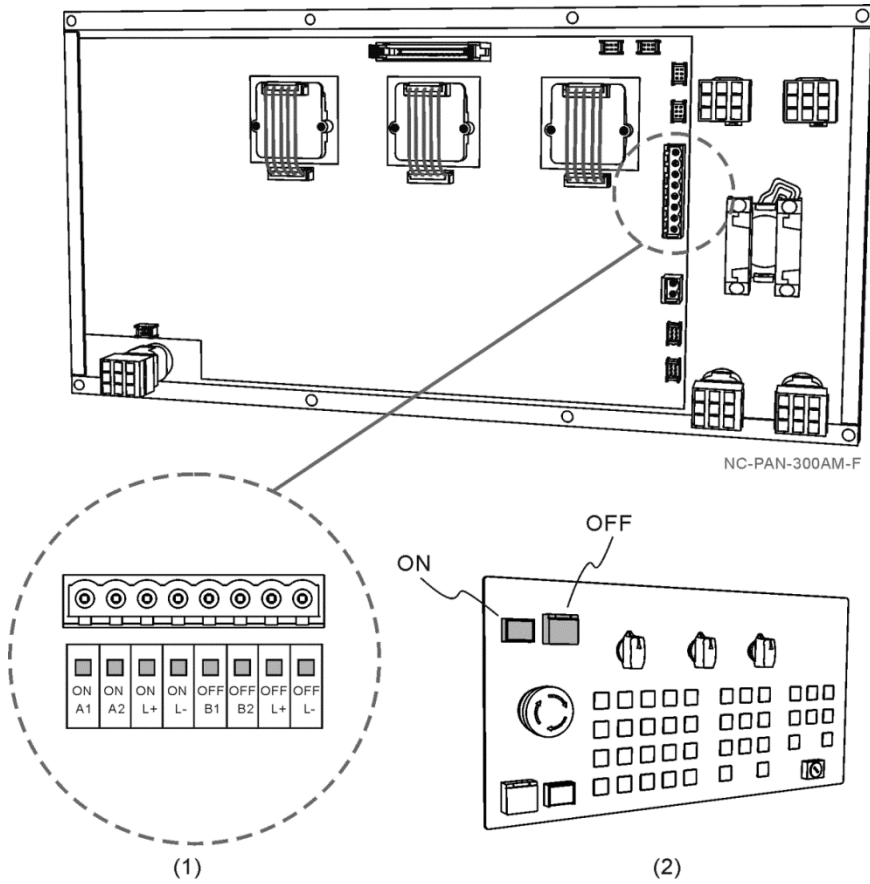

(1) Description of the connector

The power indicator requires a 24 V<sub>DC</sub> power system; to light up the Power On indicator, +24 V<sub>DC</sub> power must be inputted to the ONL+ pin and 0V must be inputted to the ONL- pin; to light up the Power Off indicator, +24 V<sub>DC</sub> must be inputted to the OFFL+ pin and 0V must be inputted to the OFFL- pin.

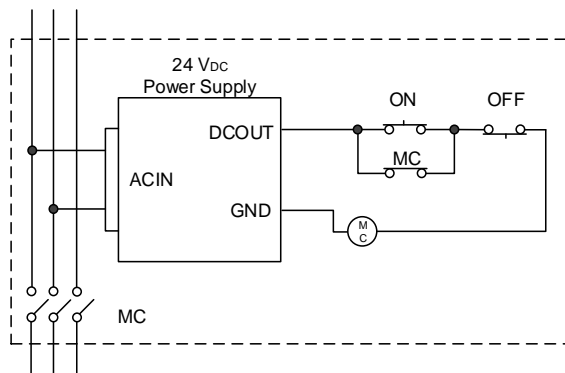

When the Power On key is pressed, the circuit between ONA1 and ONA2 is closed; when the Power Off key is pressed, the circuit between OFFB1 and OFFB2 is open.

(2) Front view diagram of Power On / Off

NC-PAN-300AM-P is equipped with I/O, and the wiring is as follows:

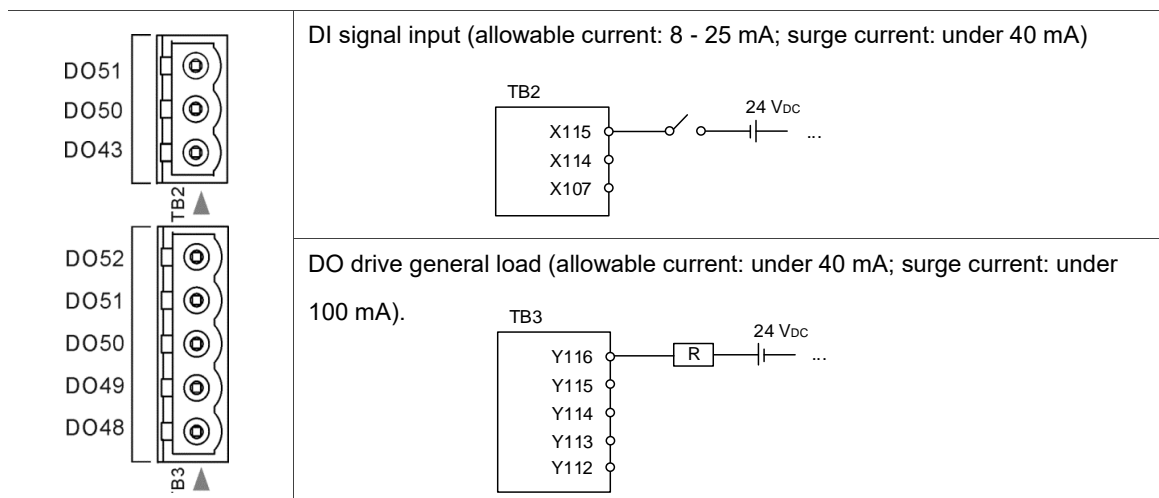



### 3.1.14 Wiring for I/O connector on machine operation panel B of NC311 series models

NC-PAN-311AM-F (P)

3

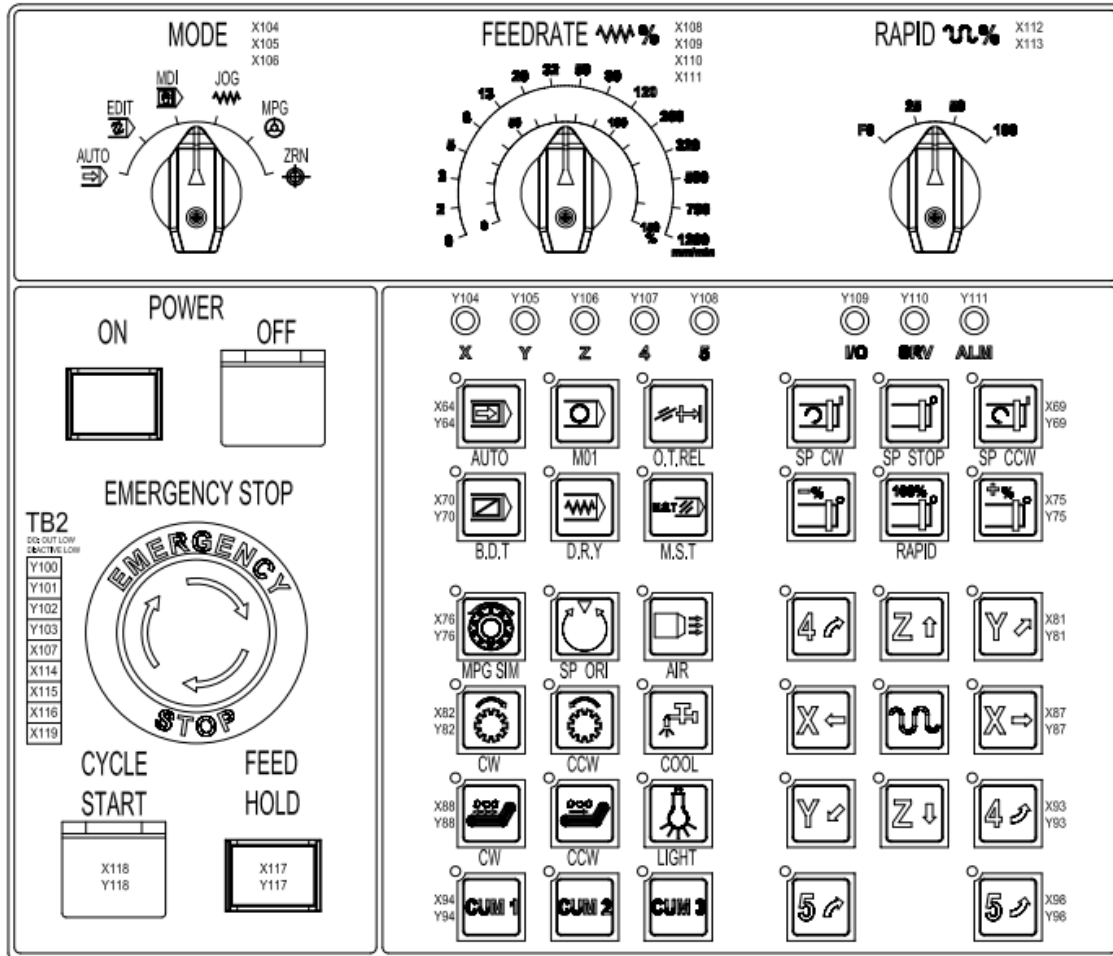

NC-PAN-311AM-F (P) E

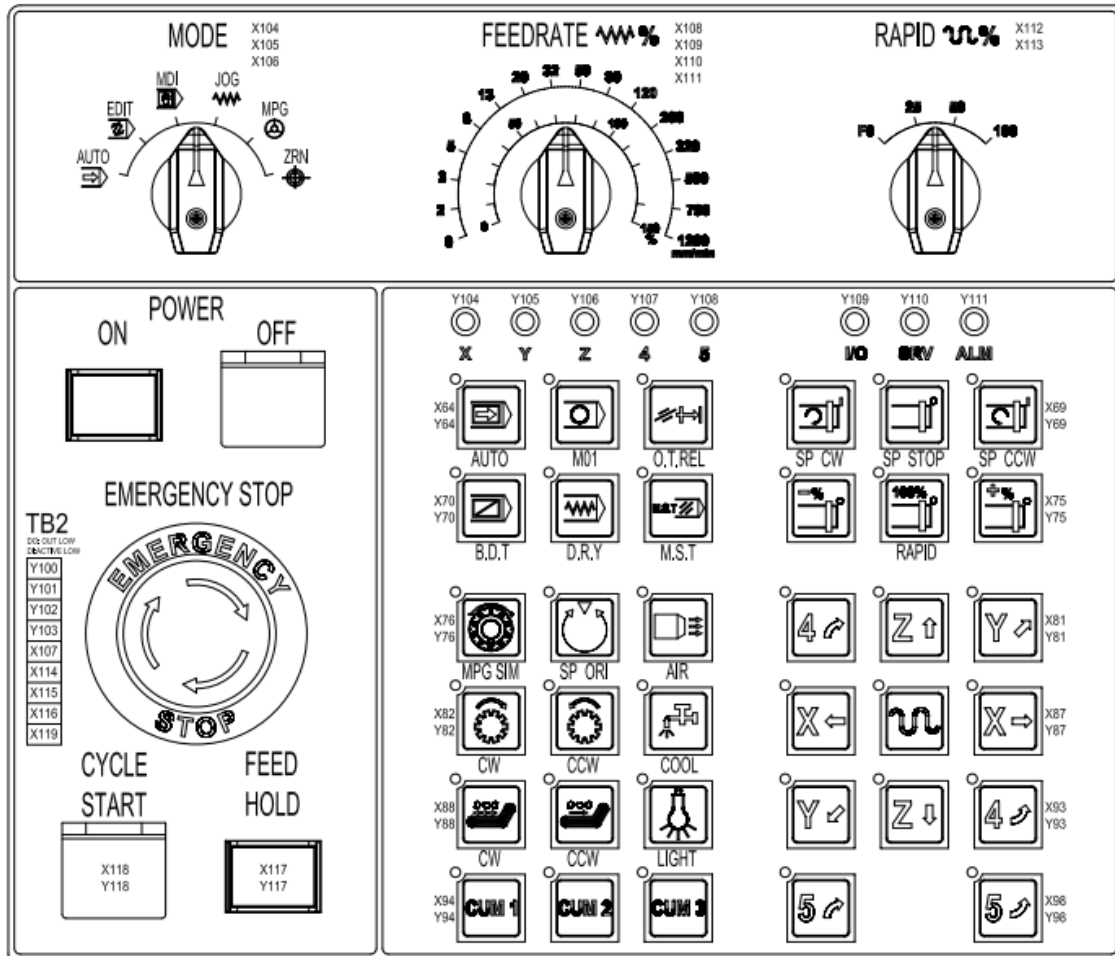

3

# 3

## Wiring of the connector

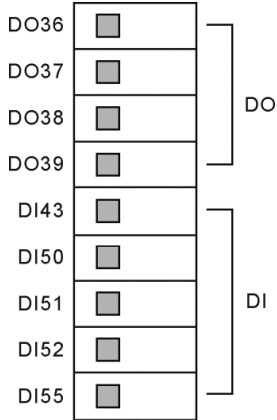
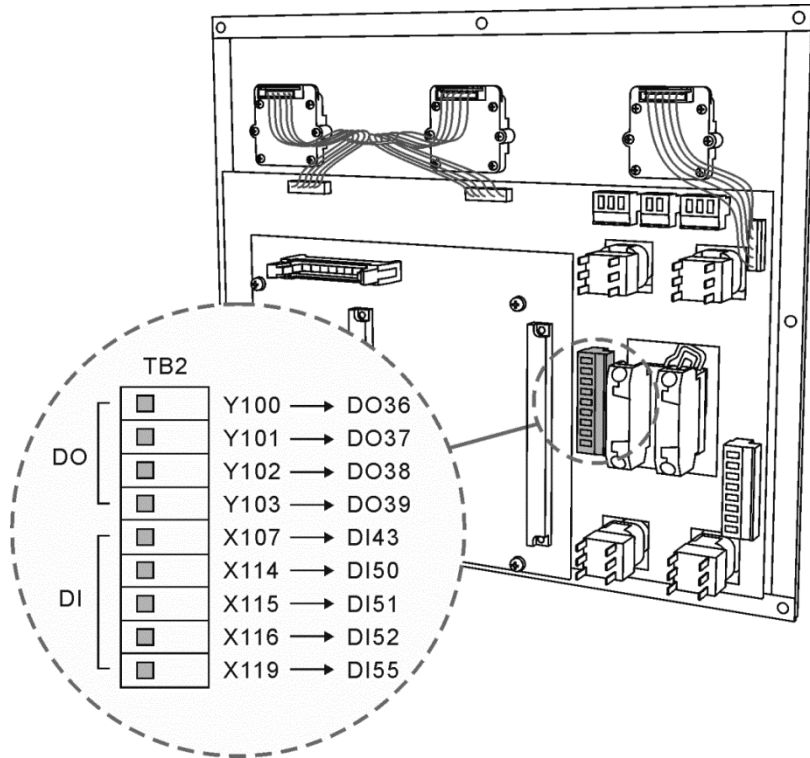

### DO drive general load

(allowable current: under 40 mA; surge current: under 100mA).

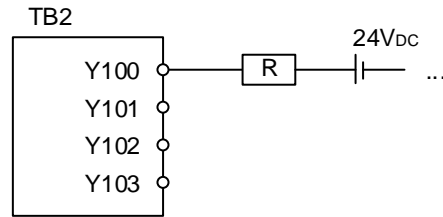

### DI signal input

(allowable current: 8 - 25 mA; surge current: under 40 mA)

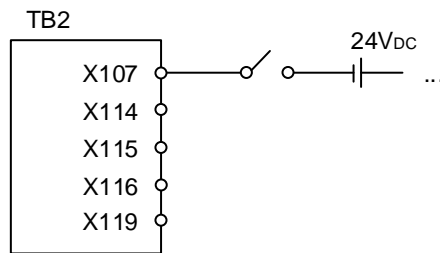

### 3.2 B series product

#### 3.2.1 B series system interface

- NC3□□ B series

NC300B\_-MI-A\_

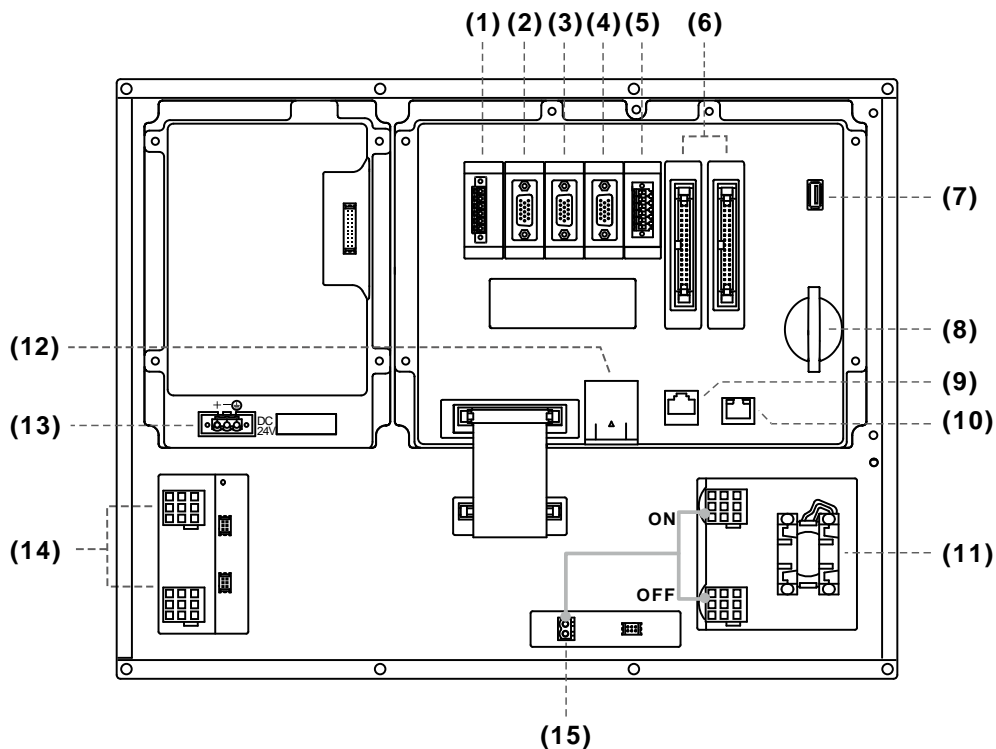

Detailed description of each connector

No.	Connector	Description
(1)	Remote I/O	Connects to high-speed serial I/O module: each module has 32 DI and 32 DO points. The maximum distance between stations is 20 m, and the total length can be up to 160 m (= 20 m x 8).
(2)	MPG	Connects to an external MPG (powered by the built-in 5 V <sub>bc</sub> power). 8 DI points are available.
(3)	Spindle 1	One set of spindle encoder input signal. One set of spindle pulse output signal.
(4)	Spindle 2	One set of spindle encoder input signal. One set of spindle pulse output signal.
(5)	CN1	RS-485 serial port for communication with external devices. Two sets of DA analog voltage output. Two sets of high-speed counter input. Emergency stop contact.
(6)	Local I/O	I/O 1: 16 DI / 16 DO points. I/O 2: 5 DI / 5 DO points.
(7)	USB	For storing G-code programs.
(8)	CF card	For storing G-code programs.
(9)	DMCNET	High-speed communication network connector.
(10)	Ethernet	For DNC control and system monitoring.

3

No.	Connector	Description
(11)	Emergency stop	When the button is pressed, the IES circuit is open, causing the system to stop immediately.
(12)	Battery holder	-
(13)	24 V <sub>DC</sub> power	24 V <sub>DC</sub> power input for supplying 24 V <sub>DC</sub> power to the controller.
(14)	CYCLE START / FEED HOLD	-
(15)	24 V <sub>DC</sub> power	For supplying 24 V <sub>DC</sub> power to machine operation panel B.

Safety precautions for installation:

1. Check if the wiring for 24 V<sub>DC</sub> power is correct.
2. Both local I/O and remote I/O require an additional 24 V<sub>DC</sub> power supply to drive X input and Y output.
3. Short-circuit EMG (emergency stop) to have the controller ready for use.
4. If an alarm occurs or the emergency stop signal is on, power off the servo drive by disconnecting the power at the magnetic contactor (MC) with Y output.

NC300B\_-MS-A\_

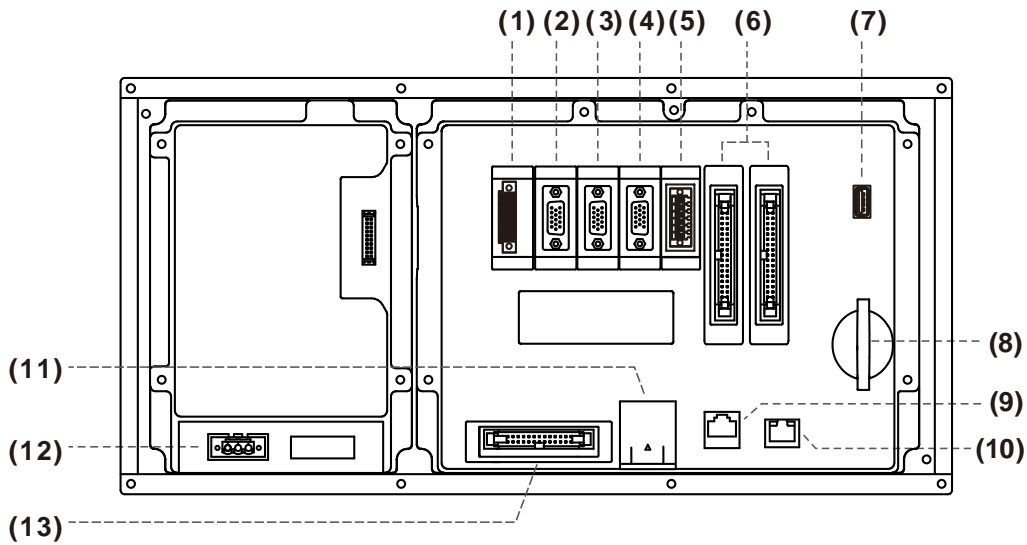

Detailed description of each connector

No.	Connector	Description
(1)	Remote I/O	Connects to high-speed serial I/O module: each module has 32 DI and 32 DO points. The maximum distance between stations is 20 m, and the total length can be 160 m (= 20 m x 8).
(2)	MPG	Connects to an external MPG (powered by the built-in 5 V <sub>DC</sub> power). 8 DI points are available.
(3)	Spindle 1	One set of spindle encoder input signal. One set of spindle pulse output signal.
(4)	Spindle 2	One set of spindle encoder input signal. One set of spindle pulse output signal.
(5)	CN1	RS-485 serial port for communication with external devices. Two sets of DA analog voltage output. Two sets of high-speed counter input. Emergency stop contact.
(6)	Local I/O	I/O 1: 16 DI / 16 DO points. I/O 2: 5 DI / 5 DO points.
(7)	USB	For storing G-code programs.
(8)	CF card	For storing G-code programs.
(9)	DMCNET	High-speed communication network connector.
(10)	Ethernet	For DNC control and system monitoring.
(11)	Battery holder	-
(12)	24 V <sub>DC</sub> power	24 V <sub>DC</sub> power input for supplying 24 V <sub>DC</sub> power to the controller.
(13)	Cable slot for machine operation B	-

Safety precautions for installation:

1. Check if the wiring for 24 V<sub>DC</sub> power is correct.
2. Both local I/O and remote I/O require an additional 24 V<sub>DC</sub> power supply to drive X input and Y output.
3. Short-circuit EMG (emergency stop) to have the controller ready for use.
4. If an alarm occurs or the emergency stop signal is on, power off the servo drive by disconnecting the power at the magnetic contactor (MC) with Y output.

NC301B-MS-A\_

3

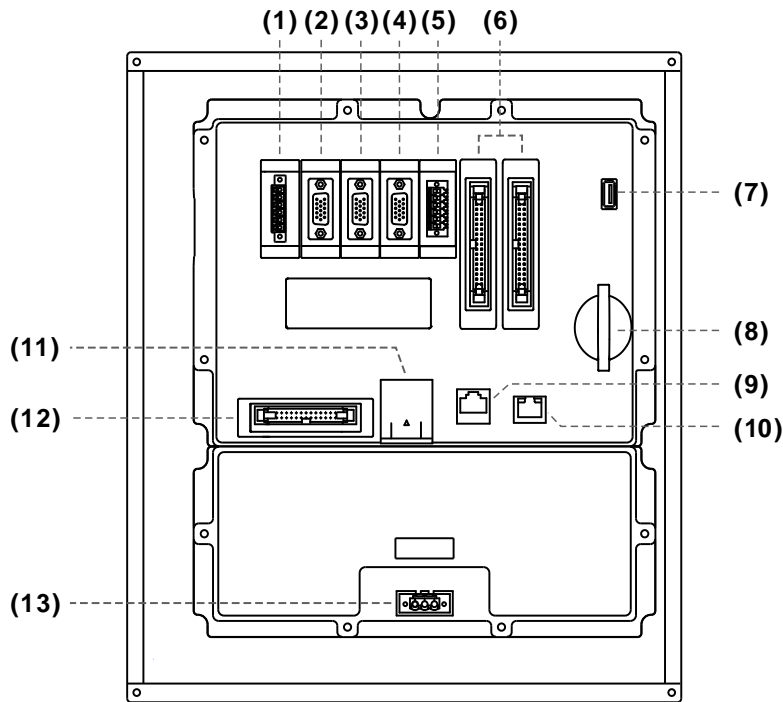

Detailed description of each connector

No.	Connector	Description
(1)	Remote I/O	Connects to high-speed serial I/O module: each module has 32 DI 32 DO points. THhe maximum distance between stations is 20 m, and the total length can be up to 160 m (= 20 m x 8).
(2)	MPG	Connects to an external MPG (powered by the built-in 5 V <sub>DC</sub> power). 8 DI points are available.
(3)	Spindle 1	One set of spindle encoder input signal. One set of spindle pulse output signal.
(4)	Spindle 2	One set of spindle encoder input signal. One set of spindle pulse output signal.
(5)	CN1	RS-485 serial port for communication with external devices. Two sets of DA analog voltage output. Two sets of high-speed counter input. Emergency stop contact.
(6)	Local I/O	I/O 1: 16 DI / 16 DO points. I/O 2: 5 DI / 5 DO points.
(7)	USB	For storing G-code programs.
(8)	CF card	For storing G-code programs.
(9)	DMCNET	High-speed communication network connector.
(10)	Ethernet	For DNC control and system monitoring.
(11)	Battery holder	-
(12)	Cable slot for machine operation panel B	-
(13)	24 V <sub>DC</sub> power	24 V <sub>DC</sub> power input for supplying 24 V <sub>DC</sub> power to the controller.

Safety precautions for installation:

1. Check if the wiring for 24 V<sub>DC</sub> power is correct.

2. Both local I/O and remote I/O require an additional 24 V<sub>DC</sub> power supply to drive X input and Y output.
3. Short-circuit EMG (emergency stop) to have the controller ready for use.
4. If an alarm occurs or the emergency stop signal is on, power off the servo drive by disconnecting the power at the magnetic contactor (MC) with Y output.

NC310B-MS-A\_

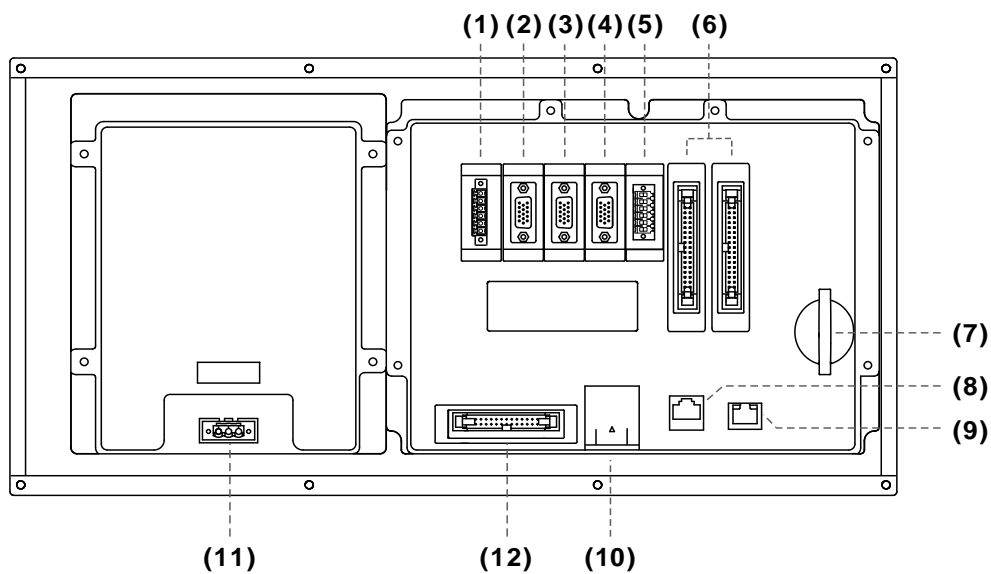

Detailed description of each connector

No.	Connector	Description
(1)	Remote I/O	Connects to high-speed serial I/O module: each module has 32 DI and 32 DO points. The maximum distance between stations is 20 m, and the total length can be up to 160 m (= 20 m x 8).
(2)	MPG	Connects to an external MPG (powered by the built-in 5 V <sub>DC</sub> power). 8 DI points are available.
(3)	Spindle 1	One set of spindle encoder input signal. One set of spindle pulse output signal.
(4)	Spindle 2	One set of spindle encoder input signal. One set of spindle pulse output signal.
(5)	CN1	RS-485 serial port for communication with external devices. Two sets of DA analog voltage output. Two sets of high-speed counter input. Emergency stop contact.
(6)	Local I/O	I/O 1: 16 DI / 16 DO points. I/O 2: 5 DI / 5 DO points.
(7)	CF card	For storing G-code programs.
(8)	DMCNET	High-speed communication network connector.
(9)	Ethernet	For DNC control and system monitoring.
(10)	Battery holder	-
(11)	24 V <sub>DC</sub> power	24 V <sub>DC</sub> power input for supplying 24 V <sub>DC</sub> power to the controller.
(12)	Cable slot for machine operation panel B	-



## 3

Safety precautions for installation:

1. Check if the wiring for 24 V<sub>DC</sub> power is correct.
2. Both local I/O and remote I/O require an additional 24 V<sub>DC</sub> power supply to drive X input and Y output.
3. Short-circuit EMG (emergency stop) to have the controller ready for use.
4. If an alarm occurs or the emergency stop signal is on, power off the servo drive by disconnecting the power at the magnetic contactor (MC) with Y output.

NC311B-MS-A

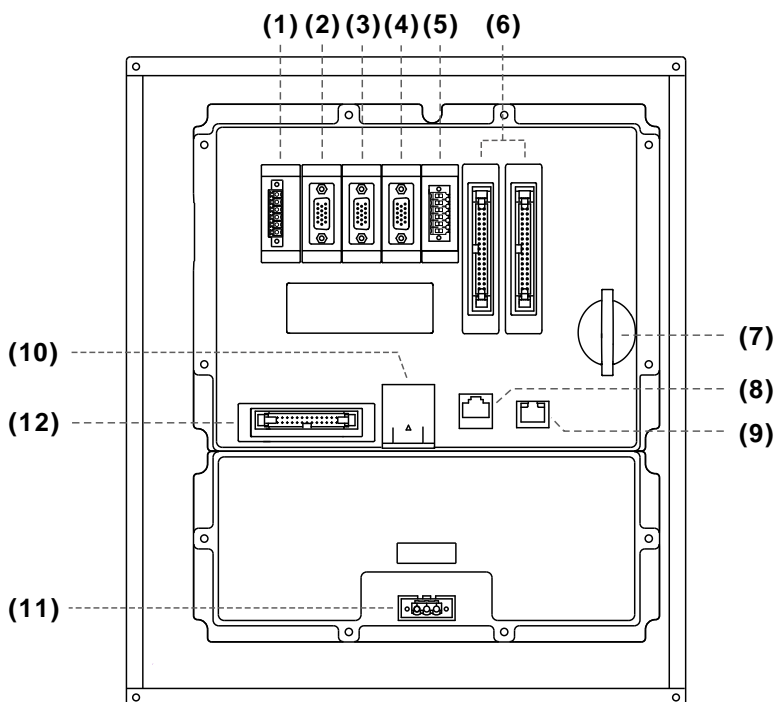

Detailed description of each connector

No.	Connector	Description
(1)	Remote I/O	Connects to high-speed serial I/O module: each module has 32 DI 32 DO points. The maximum distance between stations is 20 m, and the total length can be up to 160 m (20 m x 8).
(2)	MPG	Connects to an external MPG (powered by the built-in 5 V <sub>DC</sub> power). 8 DI points are available
(3)	Spindle 1	One set of spindle encoder input signal. One set of spindle pulse output signal.
(4)	Spindle 2	One set of spindle encoder input signal. One set of spindle pulse output signal.
(5)	CN1	RS-485 serial port for communication with external devices. Two sets of DA analog voltage output. Two sets of high-speed counter input. Emergency stop contact.
(6)	Local I/O	I/O 1: 16 DI / 16 DO points. I/O 2: 5 DI / 5 DO points.
(7)	CF card	For storing G-code programs.
(8)	DMCNET	High-speed communication network connector.
(9)	Ethernet	For DNC control and system monitoring.
(10)	Battery holder	-
(11)	24 V <sub>DC</sub> power	24 V <sub>DC</sub> power input for supplying 24 V <sub>DC</sub> power to the controller.
(12)	Cable slot for machine operation panel B	-

Safety precautions for installation:

1. Check if the wiring for 24 V<sub>DC</sub> power is correct.
2. Both local I/O and remote I/O require an additional 24 V<sub>DC</sub> power supply to drive X input and Y output.

# 3

3. Short-circuit EMG (emergency stop) to have the controller ready for use.
4. If an alarm occurs or the emergency stop signal is on, power off the servo drive by disconnecting the power at the magnetic contactor (MC) with Y output.

■ NC200 series

NC200B-MI-A

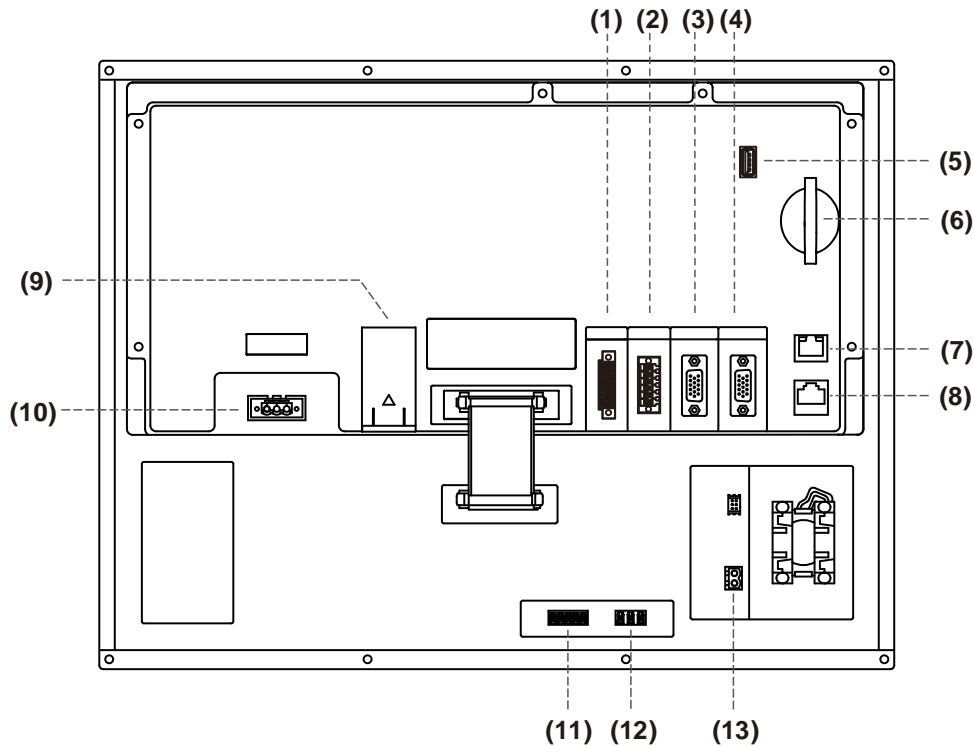

Detailed description of each connector

No.	Connector	Description
(1)	Remote I/O	Connects to high-speed serial I/O module: each module has 32 DI and 32 DO points. The maximum distance between stations is 20 m, and the total length can be up to 160 m (= 20 m x 8).
(2)	CN1	RS-485 serial port for communication with external devices. Two sets of DA analog voltage output. Two sets of high-speed counter input. Emergency stop contact.
(3)	Spindle	One set of spindle encoder input signal. One set of spindle pulse output signal.
(4)	MPG	Connects to an external MPG (powered by the built-in 5 V <sub>DC</sub> power). 8 DI points are available.
(5)	USB	For storing G-code programs.
(6)	CF card	For storing G-code programs.
(7)	Ethernet	For DNC control and system monitoring.
(8)	DMCNET	High-speed communication network connector.
(9)	Battery holder	-
(10)	24 V <sub>DC</sub> power	24 V <sub>DC</sub> power input for supplying 24 V <sub>DC</sub> power to the controller.
(11)	Local I/O input terminal	5 input points.

No.	Connector	Description
(12)	Local I/O output terminal	3 output points.
(13)	24 V <sub>DC</sub> power	24 V <sub>DC</sub> power input for supplying 24 V <sub>DC</sub> power to panel B.

Safety precautions for installation:

1. Check if the wiring for 24 V<sub>DC</sub> power is correct.
2. Remote I/O requires an additional 24 V<sub>DC</sub> power supply to drive X input and Y output.
3. Short-circuit IES (emergency stop) to have the controller ready for use.
4. If an alarm occurs or the emergency stop signal is on, power off the servo drive by disconnecting the power at the magnetic contactor (MC) with Y output.

■ OPENCNC series

NC30EB(H)

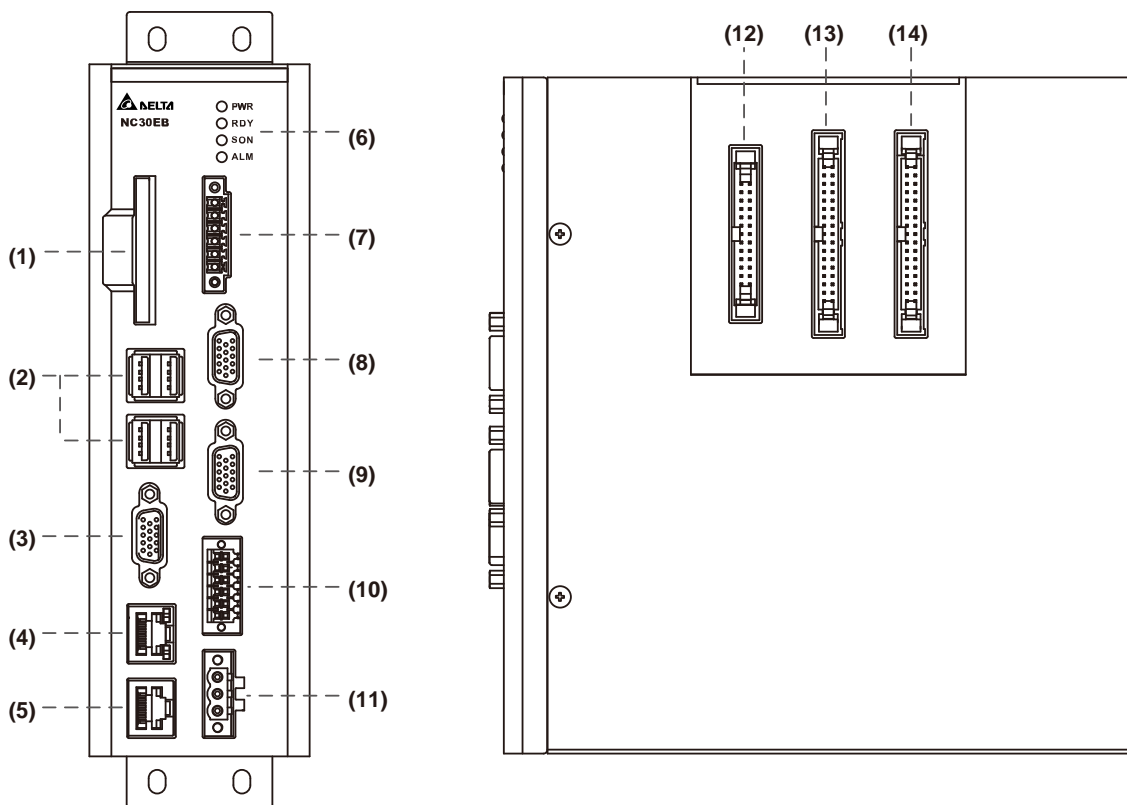

Detailed description of each connector

No.	Connector	Description
(1)	CF card	For storing G-code programs.
(2)	USB	Three USB host connectors for connecting to the mouse, keyboard, and flash drive.
(3)	VGA	For connecting to a screen.
(4)	Ethernet	For DNC control and system monitoring.
(5)	DMCNET	High-speed communication network connector.
(6)	Indicators	-



No.	Connector	Description
(7)	Remote I/O	Connects to high-speed serial I/O module: each module has 32 DI and 32 DO points. The maximum distance between stations is 20 m, and the total length can be up to 160 m (20 m x 8).
(8)	MPG	Connects to an external MPG (powered by the built-in 5 V <sub>DC</sub> power). 8 DI points are available.
(9)	Spindle	One set of spindle encoder input signal. One set of spindle pulse output signal.
(10)	CN1	RS-485 serial port for communication with external devices. Two sets of DA analog voltage output. Two sets of high-speed counter input. Emergency stop contact.
(11)	24 V <sub>DC</sub> power	24 V <sub>DC</sub> power input for supplying 24 V <sub>DC</sub> power to the controller.
(12)	Keypad I/O	Connects to machine operation panel B.
(13)	I/O 1	16 DI / 16 DO points.
(14)	I/O 2	16 DI / 16 DO points.

Safety precautions for installation:

1. Check if the wiring for 24 V<sub>DC</sub> power is correct.
2. Remote I/O requires an additional 24 V<sub>DC</sub> power supply to drive X input and Y output.
3. If an alarm occurs or the emergency stop signal is on, power off the servo drive by disconnecting the power at the magnetic contactor (MC) with Y output.

**3.2.2 B series controller connectors**

**3.2.2.1 NC3□□B series connectors**

Symbol	Function	Description		
0V, +24V, 	Power input for controller	Connects to the 24 V <sub>DC</sub> power (24 W at 1 A).		
		Symbol	Cable color	Description
		+24V	Red	+24 V <sub>DC</sub> power
		0V	White	0 V <sub>DC</sub> power
	Green	Power grounding		
I/O 1	1 <sup>st</sup> set local I/O	DI/DO range: X0 - X15, Y0 - Y15.		
		Pin No.	Description	
		P1 - P16	DI points X0 - X15, 16 points in total (8 - 25 mA)	
		P19 - P34	DO points Y0 - Y15, 16 points in total (< 120 mA)	
		P18	DI COM point; connects to +24 V <sub>DC</sub> or 0V	
		P17	DO COM point; fixed at 0V	
Power specifications: voltage < 24 V <sub>DC</sub> , current < 60 mA.				
I/O 2	2 <sup>nd</sup> set local I/O	DI/DO range: X16 - X20, Y16 - Y20.		
		Pin No.	Description	
		P1 - P5	DI points X16 - X20, 5 points in total (8 - 25 mA)	
		P19 - P23	DO points Y16 - Y20, 5 points in total (< 120 mA)	
		P18	DI COM point; connects to +24 V <sub>DC</sub> or 0V	
		P17	DO COM point; fixed at 0V	
Power specifications: voltage < 24 V <sub>DC</sub> , current < 60 mA.				
CN1	CN1 terminal connector	Pin No.	Description	
		P1	RS485_D+	
		P2	RS485_D-	
		P3	RS485_GND	
		P4	HIS 1	
		P5	HIS 2	
		P6	HIS COM	
		P7	EMG	
		P8	GND	
		P9	DAC1	
		P10	DAC1_GND	
		P11	DAC2	
P12	DAC2_GND			

3

Symbol	Function	Description	
SPINDLE 1	Spindle 1 connector	Includes Spindle 1 pulse output and pulse feedback.	
		Pin No.	Description
		P1	Feedback A+
		P2	Feedback A-
		P3	Feedback B+
		P4	Feedback B-
		P5	Feedback Z+
		P6	Feedback Z-
		P7	+24V_IN
		P8	ALM_DI_IN
		P9	SERVO_ON_DO_OUT
		P10	DC +5V_OUT
		P11	Command A+
		P12	Command A-
		P13	Command B+
		P14	Command B-
P15	GND		
SPINDLE 2	Spindle 2 connector	Includes Spindle 2 pulse output and pulse feedback.	
		Pin No.	Description
		P1	Feedback A+
		P2	Feedback A-
		P3	Feedback B+
		P4	Feedback B-
		P5	Feedback Z+
		P6	Feedback Z-
		P7	+24V_IN
		P8	ALM_DI_IN
		P9	SERVO_ON_DO_OUT
		P10	DC +5V_OUT
		P11	Command A+
		P12	Command A-
		P13	Command B+
		P14	Command B-
P15	GND		

Symbol	Function	Description	
MPG	MPG connector	8 DI points and one set of differential type MPG signal input.	
		Pin No.	Description
		P1	DI_COM; connects to +24 V <sub>DC</sub> or 0V
		P2 - P9	DI (X32 - X39)
		P10	DC +5V_OUT (< 200 mA)
		P11	XA+
		P12	XA -
		P13	XB+
		P14	XB -
		P15	GND
REMOTE I/O	Remote I/O module connector	Remote I/O module communication signals, including X256 - X511 and Y256 - Y511. Each module has 32 X inputs and 32 Y outputs, and the controller can connect to up to 8 modules.	
		Pin No.	Description
		P1	TX+
		P2	TX-
		P3	RX-
		P4	RX+
		P5	GND
P6	SHIELD		
ETHERNET	Ethernet connector	Uses a RJ45 connector and can be used to connect to a PC using general network cables.	
		Pin No. / color of end A	Pin No. / color of end B
		1: orange & white	1: orange & white
		2: orange	2: orange
		3: green & white	3: green & white
		4: blue	4: blue
		5: blue & white	5: blue & white
		6: green	6: green
		7: brown & white	7: brown & white
8: brown	8: brown		
DMCNET	DMCNET connector	Connects to Delta's DMCNET servo drive with standard RJ45 connector. The wiring method is the same as that of the Ethernet connector.	
EMG	Emergency stop	Press to make an open circuit during emergencies.	
Power On	Power On connector	Power On button contact.	
Power Off	Power Off connector	Power Off button contact.	
IES	Emergency stop contact	The emergency stop contact. The EMG flag is enabled in a broken circuit. (Wired to the normally-closed contact of the emergency stop button.)	



Note:

1. The IES connector is the input contact of the emergency stop signal. Enable the EMG flag in a broken circuit.
2. The power for the light of Power On / Power Off buttons is 24 V<sub>DC</sub>.



3.2.2.2 NC200B series connectors



3

Symbol	Function	Description		
0V, +24V, 	Power input for controller	Connects to the 24 V <sub>DC</sub> power (24 W at 1 A).		
		Symbol	Cable color	Description
		+24V	Red	+24 V <sub>DC</sub> power
		0V	White	0 V <sub>DC</sub> power
	Green	Power grounding		
I/O	DI	Power specifications for DI points: voltage < 24 V <sub>DC</sub> , current: 8 - 25 mA. MI series (24V power must be supplied to the machine operation panel B.)		
		Pin No.	Description	
	X112 - X116	DI points X112 - X116 (NPN), 5 points in total.		
	DO	Power specifications for DO points: voltage < 24 V <sub>DC</sub> , current < 120 mA. MI series (24V power must be supplied to the machine operation panel B.)		
Pin No.		Description		
Y112 - Y114		DO points Y112 - Y114 (NPN), 3 points in total		
CN1	CN1 terminal connector	Pin No.	Description	
		P1	RS485_D+	
		P2	RS485_D-	
		P3	RS485_GND	
		P4	HIS 1	
		P5	HIS 2	
		P6	HIS COM	
		P7	EMG	
		P8	GND	
		P9	DAC1	
		P10	DAC1_GND	
		P11	DAC2	
		P12	DAC2_GND	

Symbol	Function	Description	
SPINDLE 1	Spindle connector	Includes spindle pulse output and pulse feedback.	
		Pin No.	Description
		P1	Feedback A+
		P2	Feedback A-
		P3	Feedback B+
		P4	Feedback B-
		P5	Feedback Z+
		P6	Feedback Z-
		P7	+24V_IN
		P8	ALM_DI_IN
		P9	SERVO_ON_DO_OUT
		P10	DC +5V_OUT
		P11	Command A+
		P12	Command A-
		P13	Command B+
		P14	Command B-
P15	GND		
MPG	MPG connector	8 DI points and 1 set of differential type MPG signal input.	
		Pin No.	Description
		P1	DI_COM; connects to +24 V <sub>DC</sub> or 0V
		P2 - P9	DI (X32 - X39)
		P10	DC +5V_OUT (< 200 mA)
		P11	XA+
		P12	XA -
		P13	XB+
		P14	XB -
		P15	GND
REMOTE I/O	Remote I/O module connector	Remote I/O module communication signals, including X256 - X511 and Y256 - Y511. Each module has 32 X inputs and 32 Y outputs, and the controller can connect to up to 8 modules.	
		Pin No.	Description
		P1	TX+
		P2	TX-
		P3	RX-
		P4	RX+
		P5	GND
P6	SHIELD		

3.2.2.3 OPENCNC series connectors

3

Symbol	Function	Description		
0V, +24V, 	Power input for controller	Connects to the 24 V <sub>DC</sub> power (24 W at 1 A).		
		Symbol	Cable color	Description
		+24V	Red	+24 V <sub>DC</sub> power
		0V	White	0 V <sub>DC</sub> power
		Green	Power grounding	
I/O 1	1 <sup>st</sup> set local I/O	DI/DO range: X0 - X15, Y0 - Y15.		
		Pin No.	Description	
		P1 - P16	DI points X0 - X15, 16 points in total (8 - 25 mA)	
		P19 - P34	DO points Y0 - Y15, 16 points in total (< 120 mA)	
		P18	COM point for DI; connects to +24 V <sub>DC</sub> or 0V	
		P17	COM point for DO; fixed at 0V	
Power specifications: voltage < 24 V <sub>DC</sub> , current < 60 mA.				
I/O 2	2 <sup>nd</sup> set local I/O	DI/DO range: X16 - X31, Y16 - Y31.		
		Pin No.	Description	
		P1 - P16	DI points X16 - X31, 16 points in total (8 - 25 mA)	
		P19 - P34	DO points Y16 - Y31, 16 points in total (< 120 mA)	
		P18	COM point for DI; connects to +24 V <sub>DC</sub> or 0V	
		P17	COM point for DO; fixed at 0V	
Power specifications: voltage < 24 V <sub>DC</sub> , current < 60 mA.				
CN1	CN1 terminal connector	Pin No.	Description	
		P1	RS485_D+	
		P2	RS485_D-	
		P3	RS485_GND	
		P4	HIS 1	
		P5	HIS 2	
		P6	HIS COM	
		P7	EMG	
		P8	GND	
		P9	DAC1	
		P10	DAC1_GND	
		P11	DAC2	
P12	DAC2_GND			

Symbol	Function	Description	
SPINDLE 1	Spindle connector	Includes spindle pulse output and pulse feedback.	
		Pin No	Description
		P1	Feedback A+
		P2	Feedback A-
		P3	Feedback B+
		P4	Feedback B-
		P5	Feedback Z+
		P6	Feedback Z-
		P7	+24V_IN
		P8	ALM_DI_IN
		P9	SERVO_ON_DO_OUT
		P10	DC +5V_OUT
		P11	Command A+
		P12	Command A-
		P13	Command B+
		P14	Command B-
P15	GND		
MPG	MPG connector	8 DI points and 1 set of differential type MPG signal input.	
		Pin No.	Description
		P1	DI_COM; connects to +24 V <sub>DC</sub> or 0V
		P2 - P9	DI (X32 - X39)
		P10	DC +5V_OUT (< 200 mA)
		P11	XA+
		P12	XA -
		P13	XB+
		P14	XB -
		P15	GND
REMOTE I/O	Remote I/O module connector	Remote I/O module communication signals, including X256 - X511 and Y256 - Y511. Each module has 32 X inputs and 32 Y outputs, and the controller can connect to up to 8 modules.	
		Pin No.	Description
		P1	TX+
		P2	TX-
		P3	RX-
		P4	RX+
		P5	GND
P6	SHIELD		

3

### 3.2.3 Wiring for power connector

The wiring for the power of the B series NC controller is divided into two types: power supply control with Power On / Off switches and direct power supply.

- Power supply control with Power On / Off switches

As shown in the following figure, Power On is the NO contact and Power Off is the NC contact; MC (electromagnetic contactor) is the power relay.

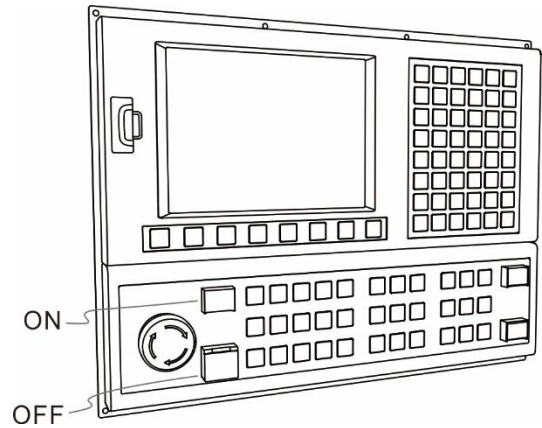
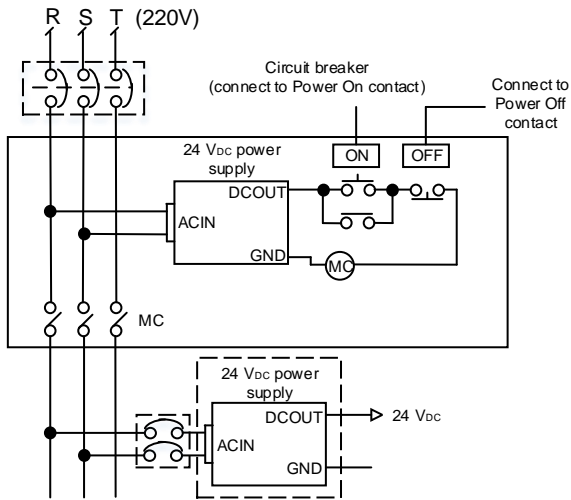

- Direct power supply

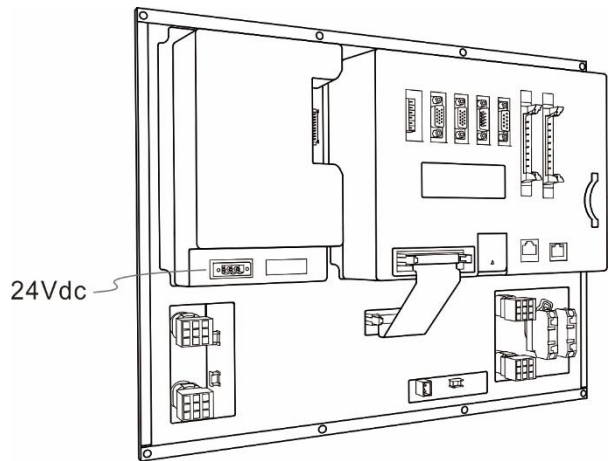
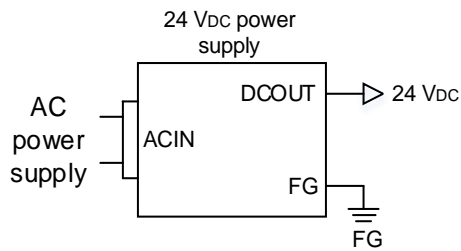

### 3.2.4 Wiring for spindle pulse output connector

The B series NC controller has the spindle pulse output for controlling the external spindle speed.

Note: the NC3□□ series all support 2 pulse spindle ports; other NC200 and OPENCNC models only support one pulse spindle port.

Pin assignment for NC3□□ series models

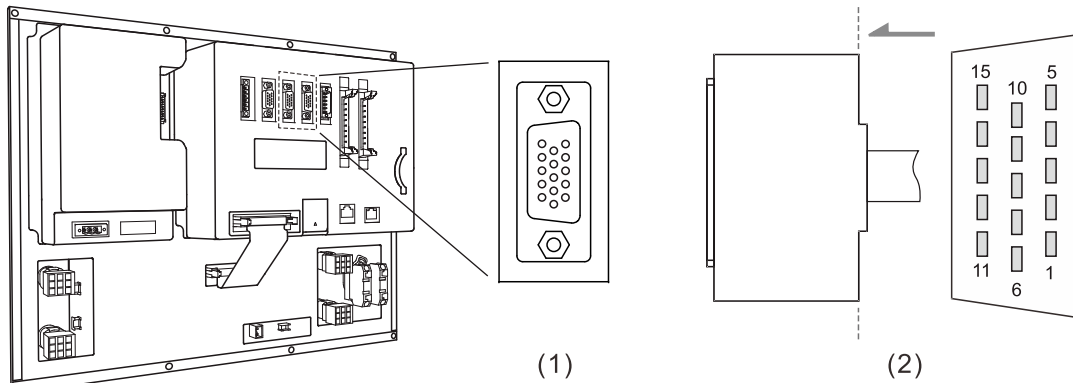

(1) Spindle pulse output connector (female); (2) Spindle pulse output connector (male)

Pin assignment for B series NC200 models

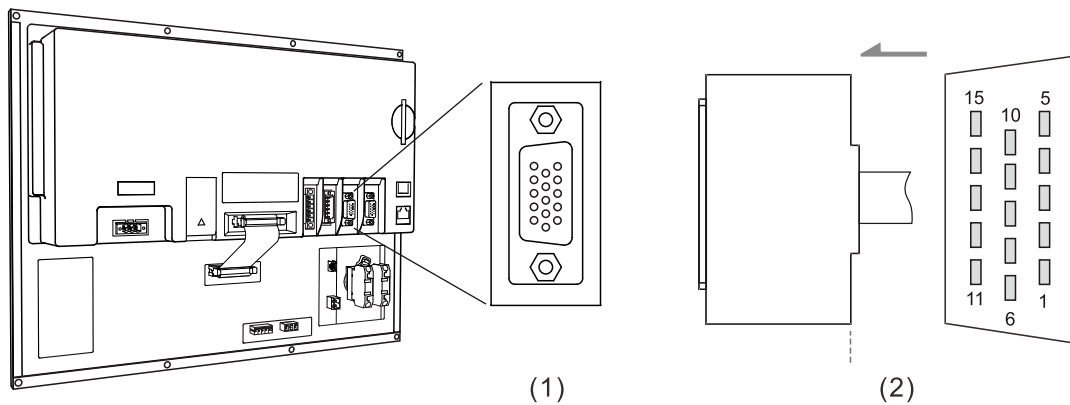

(1) Spindle pulse output connector (female); (2) Spindle pulse output connector (male)

3

Pin assignment for OPENCNC series models

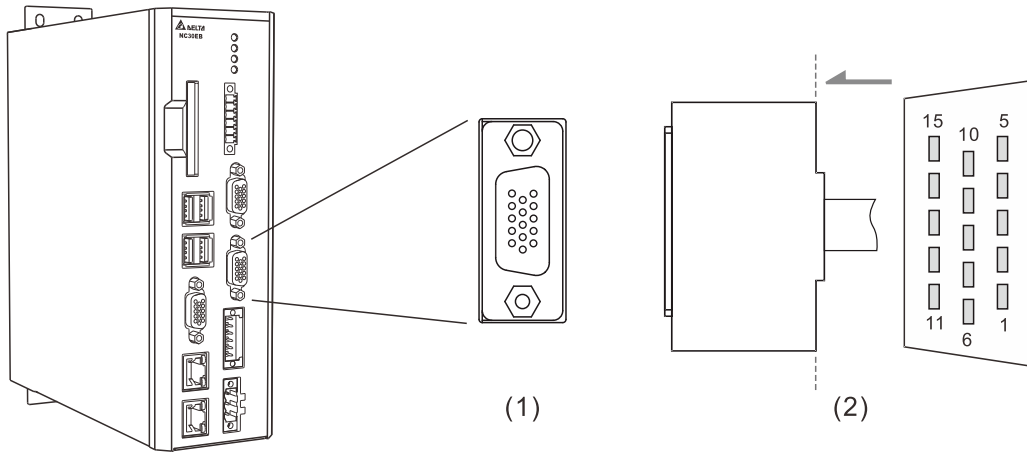

(1) Spindle pulse output connector (female); (2) Spindle pulse output connector (male)

Model	Symbol	Pin No.	Function description	
ALL	Spindle	1	Feedback A+	Pulse feedback signal A+
		2	Feedback A-	Pulse feedback signal A-
		3	Feedback B+	Pulse feedback signal B+
		4	Feedback B-	Pulse feedback signal B-
		5	Feedback Z+	Pulse feedback signal Z+
		6	Feedback Z-	Pulse feedback signal Z-
		7	+24V_IN	24V input
		8	ALM_DI_IN	ALM DI
		9	SERVO_ON_DO_OUT	Servo on signal output
		10	+5 V <sub>DC</sub> _OUT	5V voltage output
		11	Command A+	Pulse command A+
		12	Command A-	Pulse command A-
		13	Command B+	Pulse command B+
		14	Command B-	Pulse command B-
		15	GND	GND

Settings for spindle pulse output are as follows:

1. Pr399 setting

Description	Pulse control
Spindle function 0: off; 1: on	1
Closed-loop control flag 0: off 1: on (feedback encoder is required)	1
Spindle output mode 0: communication (DMCNET); 1: pulse (B series); 2: analog voltage	1
Speed control mode 1: PUU	1
Spindle encoder magnification 0: 1000 times; 1: 4 times	1
Analog spindle speed source 0: command; 1: encoder	0
Analog spindle feedback encoder source 0: spindle; 1: motor	0
Spindle voltage output mode 0: -10V to +10V 1: 0V to +10V (only effective in open loop control)	0

2. In the channel setting screen (CONFIG), enable SP1 and set its port number to 10; enable SP2 and set its port number to 11.



3

3.2.5 Wiring for RS-485 connector

The B series NC controller has one RS-485 connector for serial communication with external devices.

Pin assignment for B series NC3□□ models

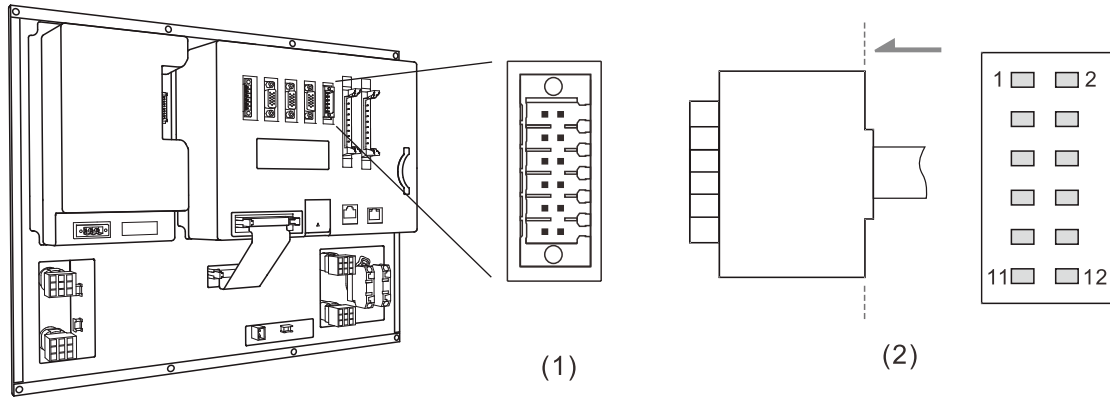

(1) CN1 connector (female); (2) RS-485 connector (male)

Model	Symbol	Pin No.	Function description
NC3_ _	CN1	1	D+
		2	D-
		3	RS485-GND

Pin assignment for B series NC200 models

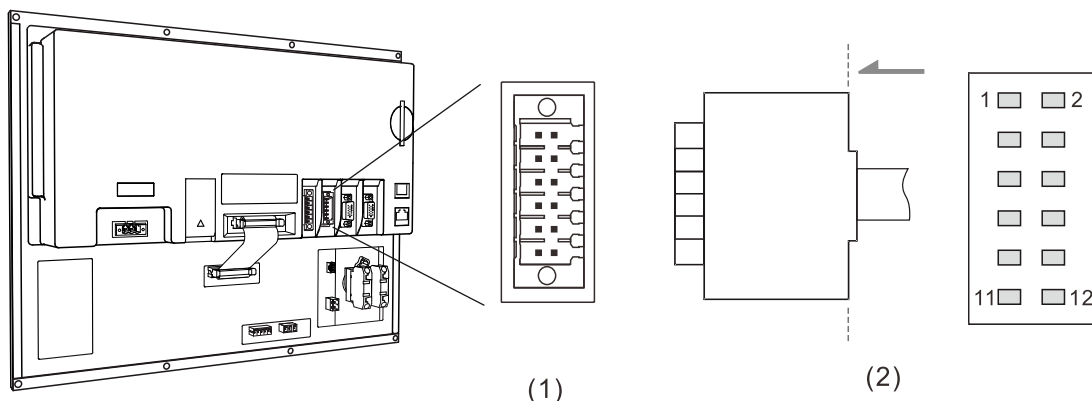

(1) CN1 connector (female); (2) RS-485 connector (male)

Model	Symbol	Pin No.	Function description
NC200	CN1	1	D+
		2	D-
		3	RS485-GND

Pin assignment for OPENCNC series models

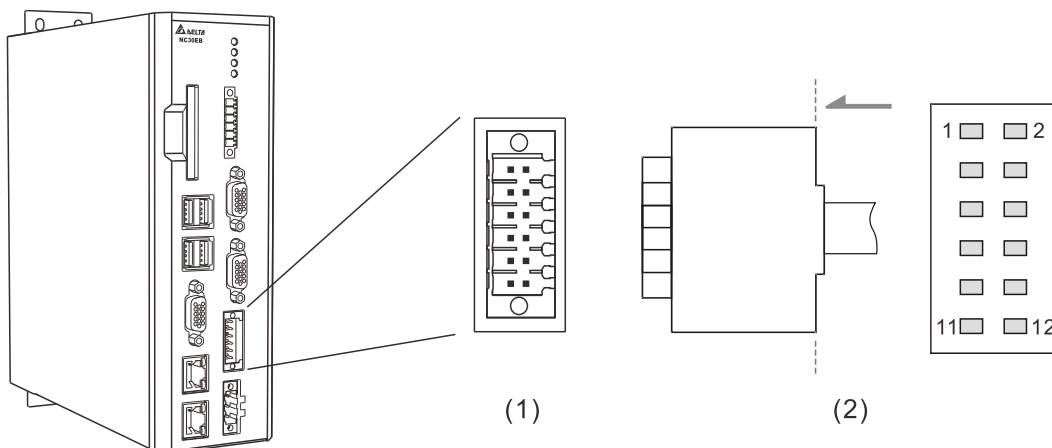

(1) CN1 connector (female); (2) RS-485 connector (male)

Model	Symbol	Pin No.	Function description
NC30EB_	CN1	1	D+
		2	D-
		3	RS485-GND

3

### 3.2.6 Wiring for spindle analog feedback connector

The NC3□□ series all support 2 external device pulse feedbacks; other NC200 and OPENCNC models only support one pulse spindle feedback.

Pin assignment for B series NC3□□ models

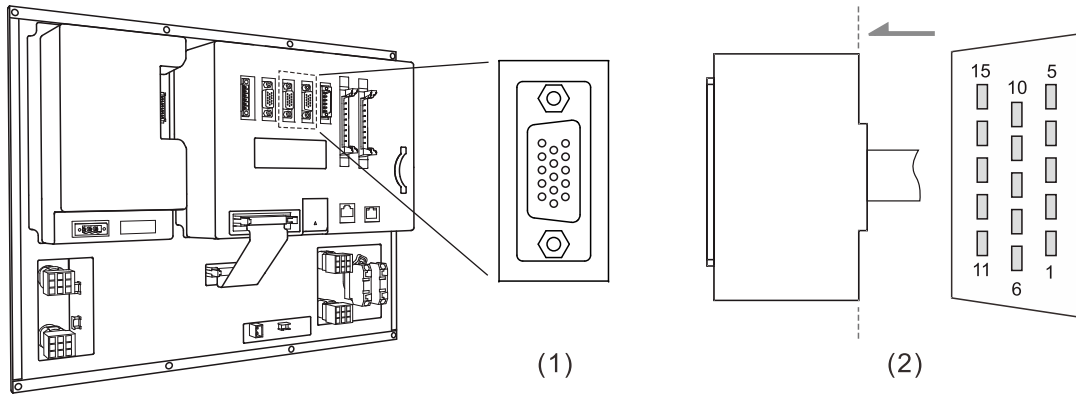

(1) Spindle feedback input connector (female); (2) Spindle feedback input connector (male)

Pin assignment for B series NC200 models

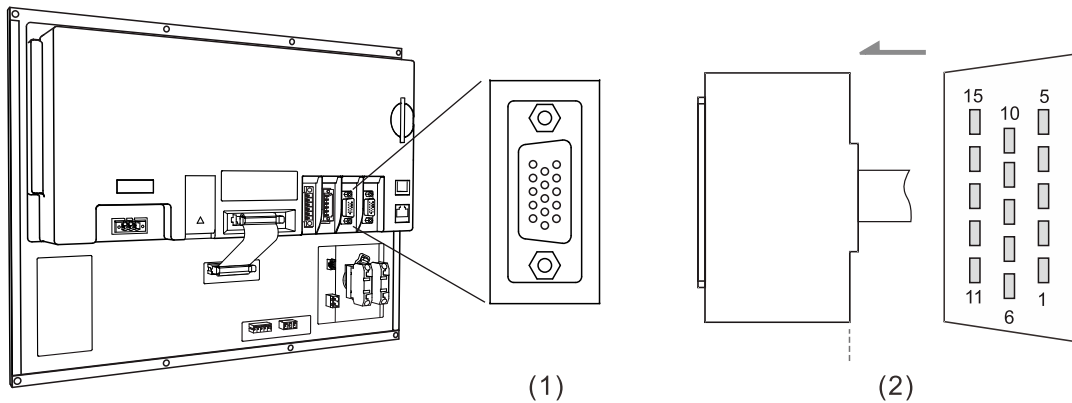

(1) Spindle feedback input connector (female); (2) Spindle feedback input connector (male)

Pin assignment for OPENCNC series models

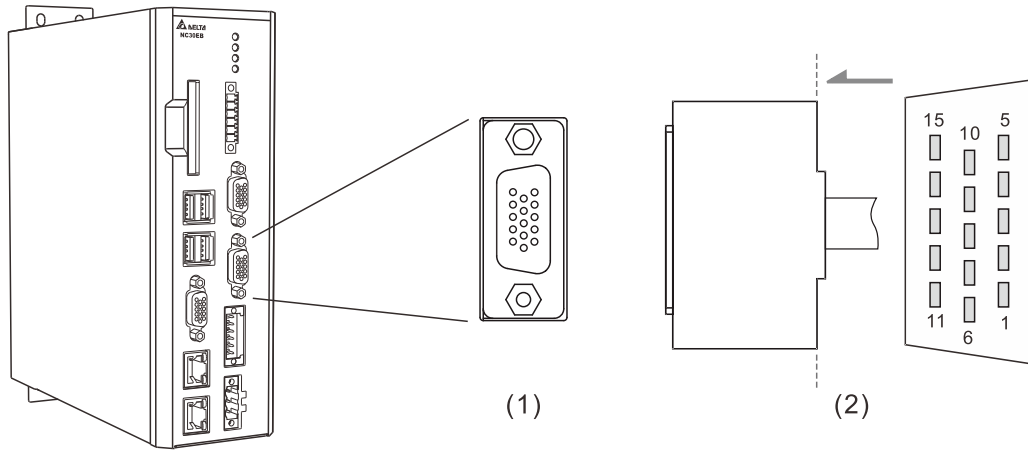

(1) Spindle feedback input connector (female); (2) Spindle feedback input connector (male)

Model	Symbol	Pin No.	Function description	
ALL	Spindle	1	Feedback A+	Pulse feedback signal A+
		2	Feedback A-	Pulse feedback signal A-
		3	Feedback B+	Pulse feedback signal B+
		4	Feedback B-	Pulse feedback signal B-
		5	Feedback Z+	Pulse feedback signal Z+
		6	Feedback Z-	Pulse feedback signal Z-
		7	+24V_IN	24V input
		8	ALM_DI_IN	ALM DI
		9	SERVO_ON_DO_OUT	Servo on voltage signal output
		10	+5 V <sub>DC</sub> _OUT	5V voltage output
		15	GND	GND

# 3

## 3.2.7 Wiring for spindle analog output connector

The B series NC controllers have 2 sets of analog voltage output, including two control methods shown as follows:

Method one: controls the rotation speed with spindle S code with acceleration / deceleration planning.

Method two: controls the voltage with special D register (range: -10V to +10V) without acceleration / deceleration planning.

Pin assignment for NC3\_\_B series models

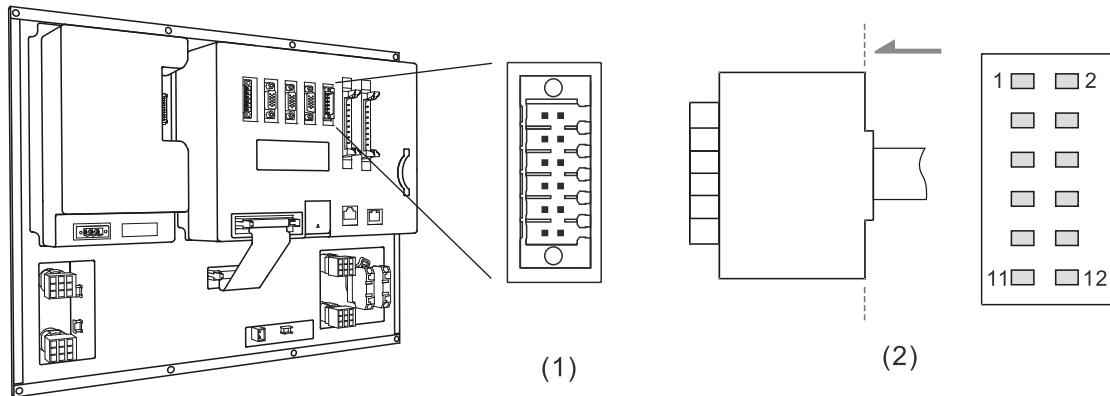

(1) CN1 connector (female); (2) CN1 analog output connector (male)

Pin assignment for NC200 B series models

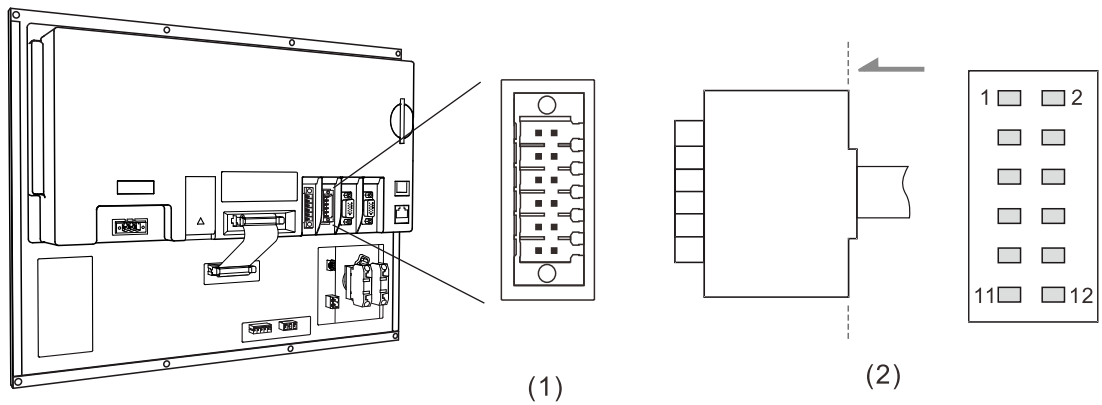

(1) CN1 connector (female); (2) CN1 analog output connector (male)

Pin assignment for OPENCNC series models

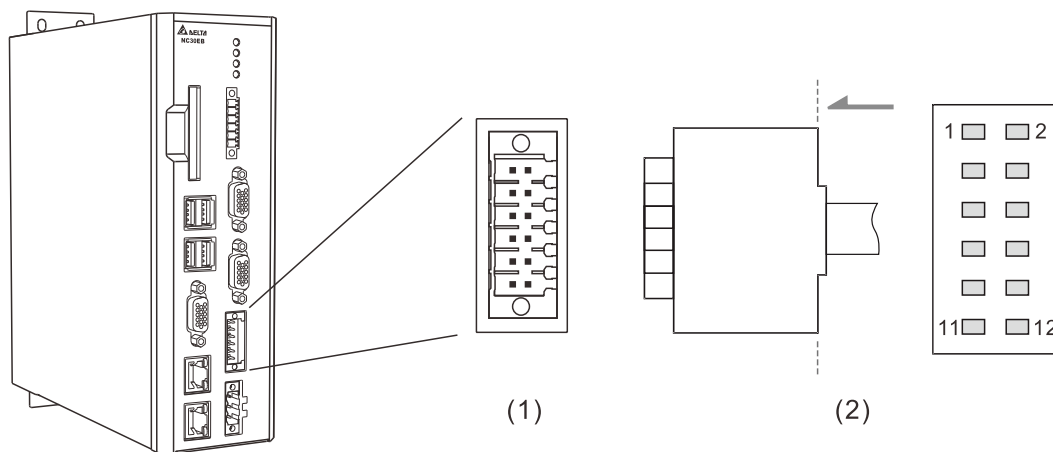

(1) CN1 analog output connector (female); (2) CN1 analog output connector (male)

Model	Symbol	Pin No.	Function description	
ALL	CN1	9	DAC_1	1 <sup>st</sup> set of analog voltage output
		10	DAC_1_GND	1 <sup>st</sup> set of DAC output_GND
		11	DAC_2	2 <sup>nd</sup> set of analog voltage output
		12	DAC_2_GND	2 <sup>nd</sup> set of DAC output_GND

Control method one: S code analog output setting instructions are as follows:

1. Pr399 setting

Description	Servo control	Analog control
Spindle function 0: off; 1: on	1	1
Closed-loop control flag 0: off 1: on (feedback encoder is required)	1	0 or 1
Spindle output mode 0: communication (DMCNET); 1: pulse (B series); 2: analog voltage	0	2
Speed control mode 1: PUU	1	1
Spindle encoder magnification 0: 1000 times; 1: 4 times	0	1
Analog spindle speed source 0: command; 1: encoder	0	1
Analog spindle feedback encoder source 0: spindle; 1: motor	0	0
Spindle voltage output mode 0 : -10V to +10V 1: 0V to +10V (only effective in open loop control)	0	0 or 1

2. In the channel setting screen (CONFIG), enable SP1 and set its port number to 10.

Note: port number 10 is dedicated for analog output.

3

Pr399 [Spindle output voltage] = 0; -10V to +10V voltage control.

Output voltage value	Corresponding rotation speed
+10 V <sub>DC</sub>	Maximum rotation speed (forward)
0 V <sub>DC</sub>	Zero speed
-10 V <sub>DC</sub>	Maximum rotation speed (reverse)

Note: this control mode can be used for closed loop and open loop controls, and can satisfy the tapping and threading functions.

Pr399 [Spindle output voltage] = 1; 0V to +10V voltage control.

Output voltage value	Corresponding rotation speed
+10 V <sub>DC</sub>	Maximum rotation speed
0 V <sub>DC</sub>	Zero speed

Note: this control mode is only applicable to open loop control and is unable to control spindle forward / reverse rotation. If there is encoder feedback signal, the threading function can be used but not the tapping function.

- In the channel setting screen (CONFIG), enable SP1 and set its port number to 10; enable SP2 and set its port number to 11.

Note: the DAC\_2 of the NC200 and OPENCNC series can only be used for open circuits; it cannot be used for receiving rotation speed feedback.

Control method two: corresponding special D registers for controlling the voltage are as follows:

Model	Symbol	Group number	Function description
ALL	CN1	DAC_1	D1125
		DAC_2	D1114

Range: -1000 to +1000 (-10V to +10V)  
Unit: 0.01

Note: the DAC\_2 pin of the NC200 and OPENCNC series can only be used for open circuits; it cannot be used for receiving rotation speed feedback.

### 3.2.8 Wiring for HSI connector

The B series NC controller has two sets of hardware high-speed counter signal input. For the wiring of high-speed counter input (bi-directional coupling), the maximum input bandwidth is up to 5 MHz; voltage: 22 - 26V; permissible current: 8 - 20 mA; surge current: below 50 mA.

The corresponding special M relay for HSI\_1 is M2142, which is applicable to G31 Skip command.

Settings of relevant parameters:

Parameter address	Parameter name	Function
Pr25	Bit 0	G31 high speed input 1 contact 0: NC; 1: NO
	Bit 1	G31 high speed input 2 contact 0: NC; 1: NO
Pr46	Bit 4	G31 high speed input 1 switch 0: off; 1: on
	Bit 5	G31 high speed input 2 switch 0: off; 1: on
Pr307	Bit 4 - 5	G31 input source 0: off; 1: HSI 1; 2: HSI 2; 3: HSI 1 & 2

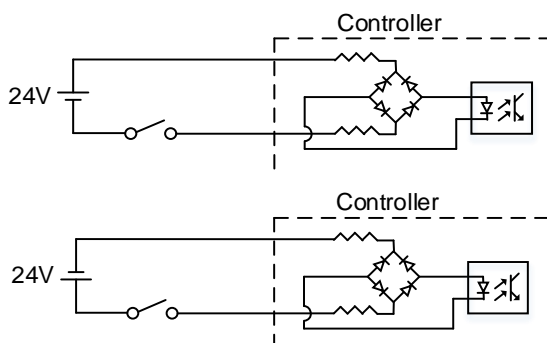

Note: the connection direction of the external power input for HSI does not affect the operation.

Pin assignment for B series NC3□□ models

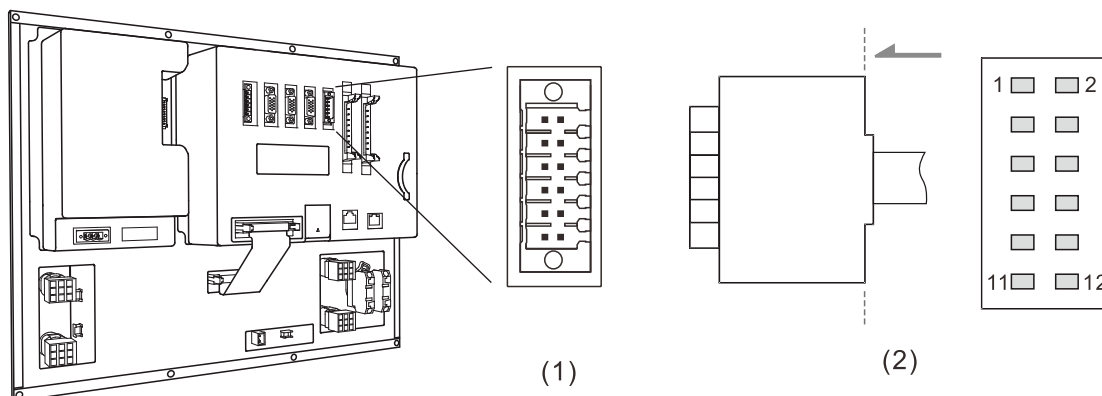

(1) CN1 connector (female); (2) CN1 high-speed counter input connector (male)



3

Pin assignment for B series NC200 models

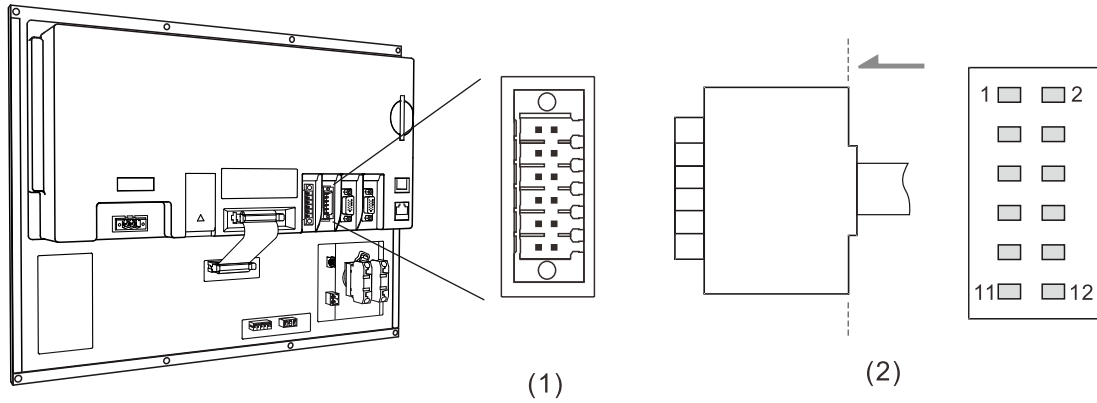

(1) CN1 connector (female); (2) CN1 high-speed counter input connector (male)

Pin assignment for OPENCNC series models

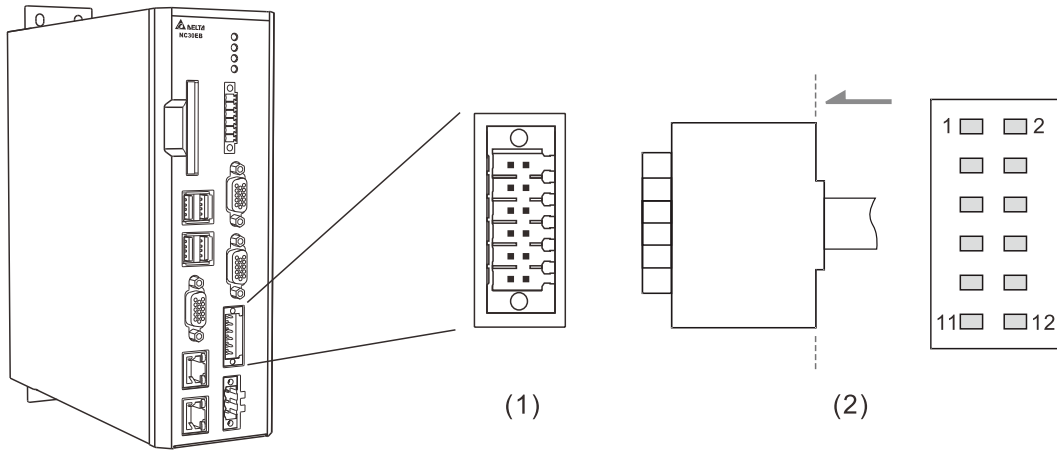

(1) CN1 high-speed counter input connector (female); (2) CN1 high-speed counter input connector (male)

Model	Symbol	Pin No.	Function description	
ALL	HSI	4	HSI_1	High-speed counter input 1 (10 mA)
		5	HSI_2	High-speed counter input 2 (10 mA)
		6	HSI_COM	High-speed counter COM; connects to +24 V <sub>DC</sub> or 0V

### 3.2.9 Wiring for emergency stop

The B series NC controller has one set of emergency stop signal input.

Pin assignment for NC3□□ series, NC200, and OPENCNC series models

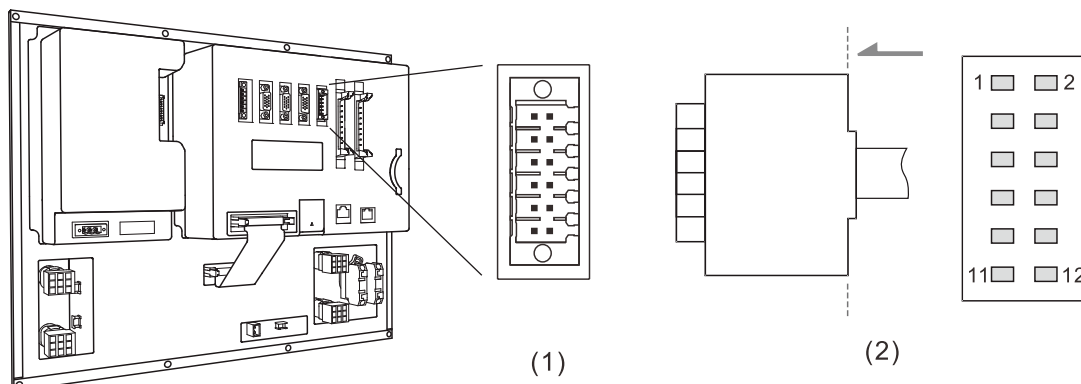

(1) CN1 connector (female); (2) CN1 pin definition

Pin assignment for B series NC200 models

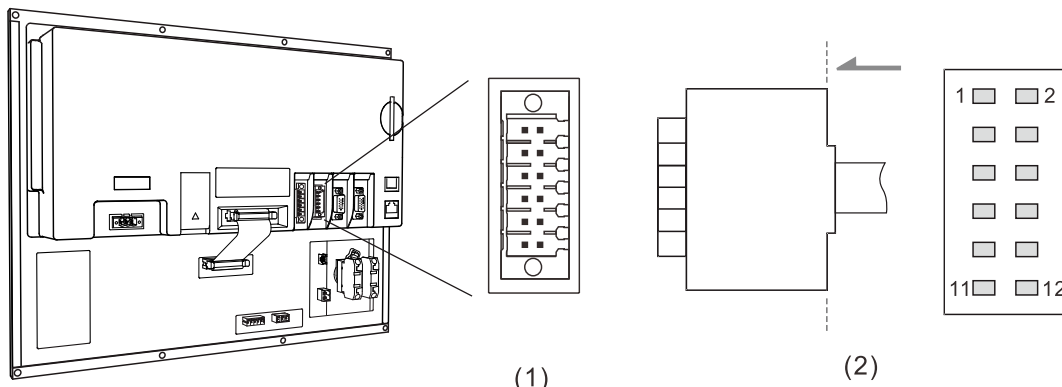

(1) CN1 connector (female); (2) CN1 pin definition

Pin assignment for OPENCNC series models

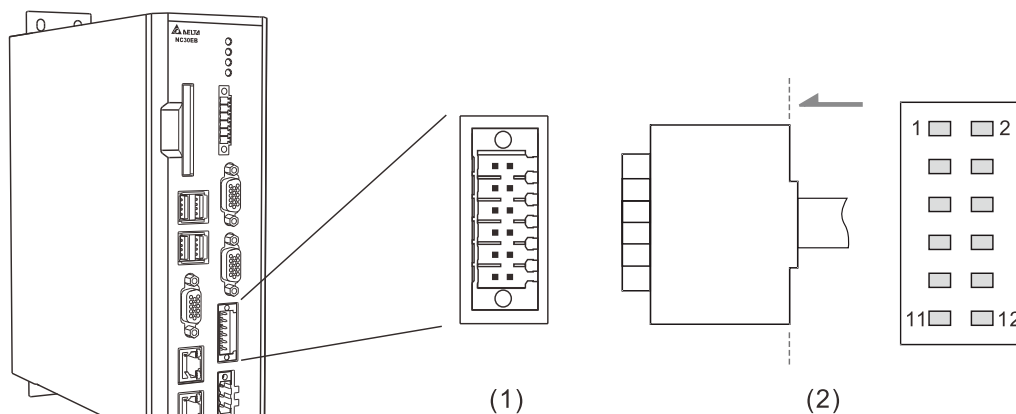

(1) CN1 connector (female); (2) CN1 pin definition

Model	Symbol	Pin No.	Function description	
ALL	CN1	7	EMG	EMG (+5 V <sub>DC</sub> output)
		8	GND	GND

Note: EMG can output +5V power and is able to form a circuit with GND for immediate use.

### 3.2.10 Wiring for MPG connector

The B series NC controller has one MPG connector for receiving MPG pulses. This connector supplies +5 V<sub>DC</sub> power which directly supplies power to the MPG.

Pin assignment for NC3□□ series models

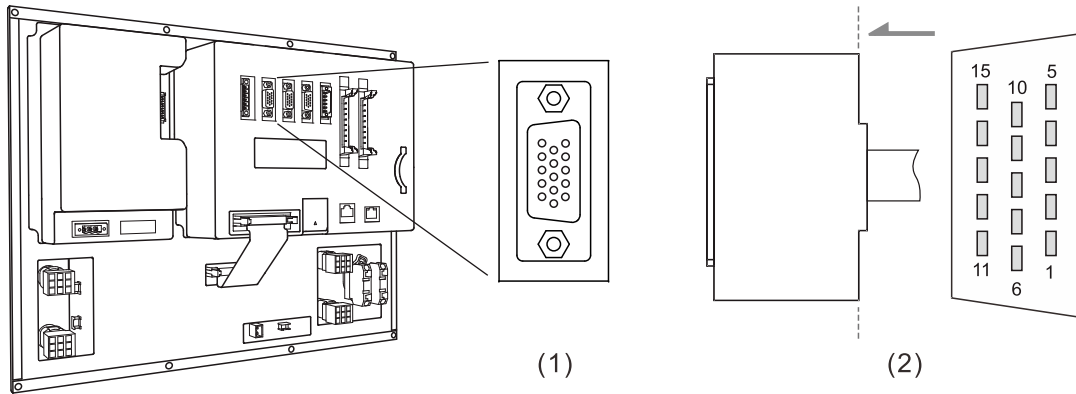

(1) MPG connector (female); (2) MPG connector (male)

Pin assignment for NC200 series models

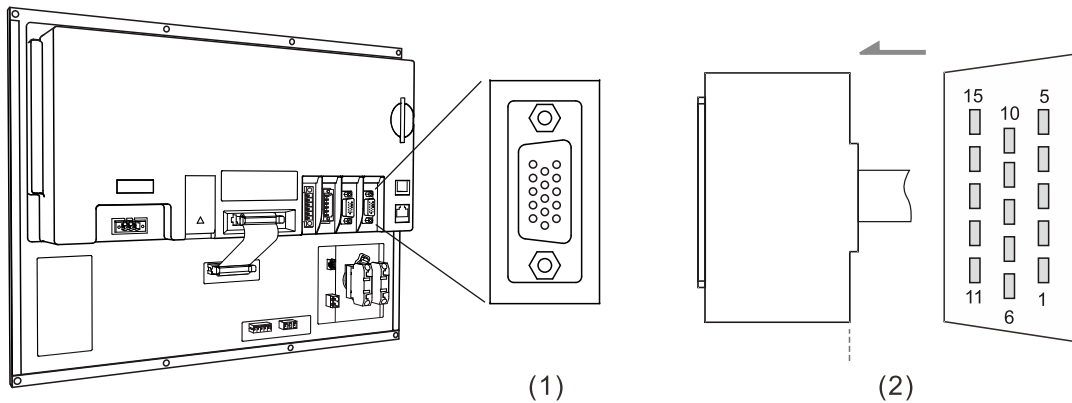

(1) MPG connector (female); (2) MPG connector (male)

Pin assignment for OPENCNC series models

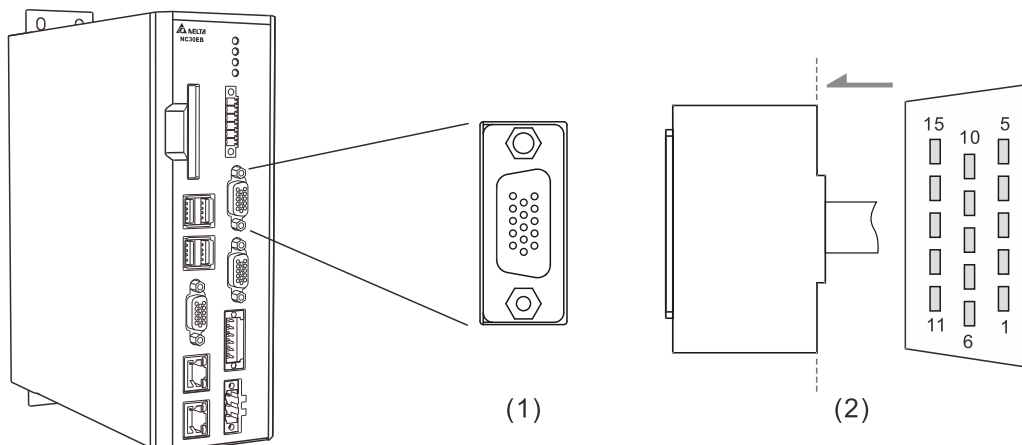

(1) MPG connector (female); (2) MPG connector (male)

Model	Symbol	Pin No.	Function description
NC3_ NC200 OPENCNC	MPG	1	EXT_24 DI COM point; connects to +24V or 0V
		2	DI_1 X32; recommended for the X axis selection input
		3	DI_2 X33; recommended for the Y axis selection input
		4	DI_3 X34; recommended for the Z axis selection input
		5	DI_4 X35; recommended for magnification x1 selection input
		6	DI_5 X36; recommended for magnification x10 selection input
		7	DI_6 X37; recommended for magnification x100 selection input
		8	DI_7 X38; recommended for the A axis selection input
		9	DI_8 X39; recommended for the B axis selection input
		10	5V_OUT 5 V <sub>DC</sub> _OUT
		11	XA+ XA+
		12	XA- XA-
		13	XB+ XB+
		14	XB- XB-
		15	5V_GND 5 V <sub>DC</sub> _GND

The signal type determines the wiring for MPG, including single-ended type (EHDW-BA6SI) and differential type (EHDW-BE6SI).

# 3

## Single-ended MPG pulse signal wiring diagram

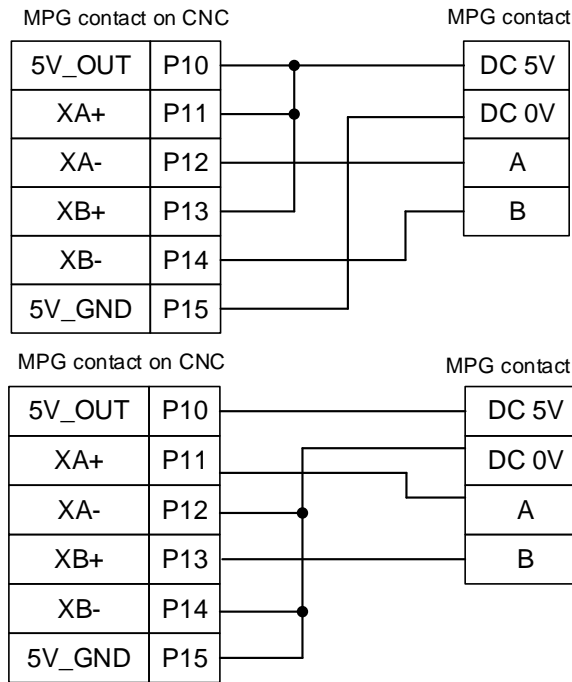

## Differential type MPG pulse signal wiring diagram

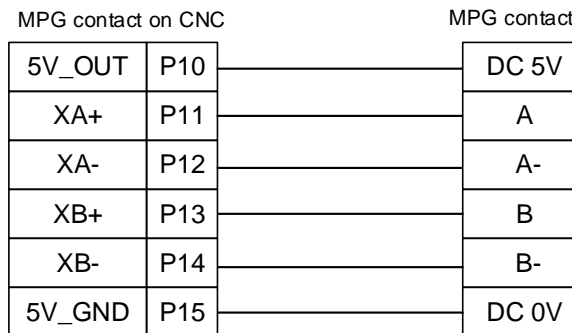

MPG switch wiring diagram

- The 5V power is supplied from the MPG contact

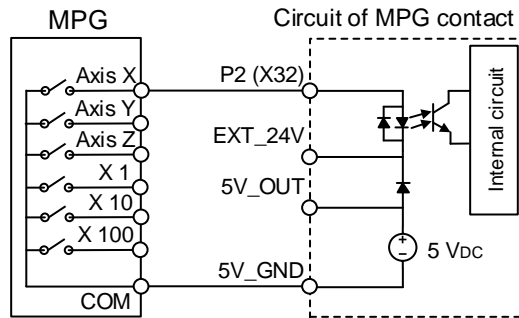

- The 24V power is supplied externally; EXT\_24 can connect to +24V or 0V

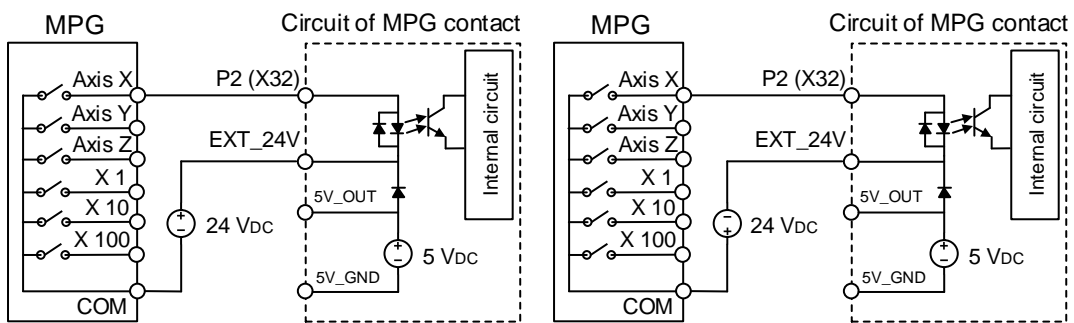

3

### 3.2.11 Wiring for remote I/O connector

After the remote I/O module is connected to the NC series controller, there are 256 output and 256 input points available. For every additional station, its I/O address will offset backwards for 32 points. Up to 8 modules can be connected simultaneously, providing a maximum of 256 output points and 256 input points.

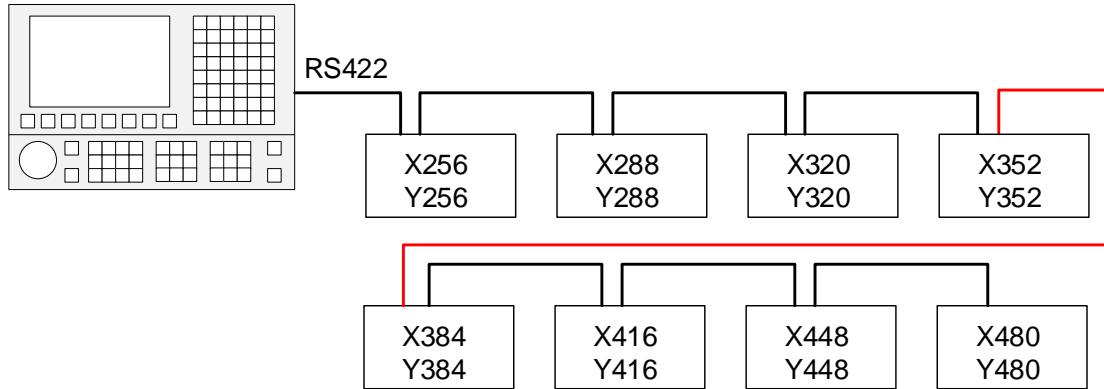

Remote I/O connector and pin definitions

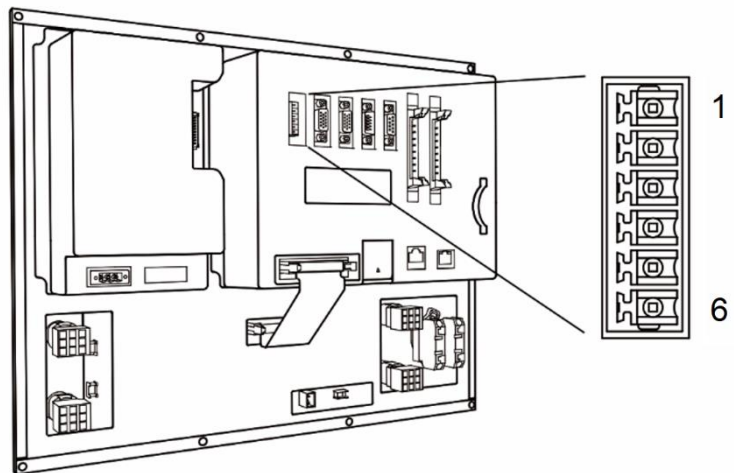

Pin No.	Function description
1	TX+
2	TX-
3	RX-
4	RX+
5	GND
6	SHIELD

Wiring diagram for remote I/O connector

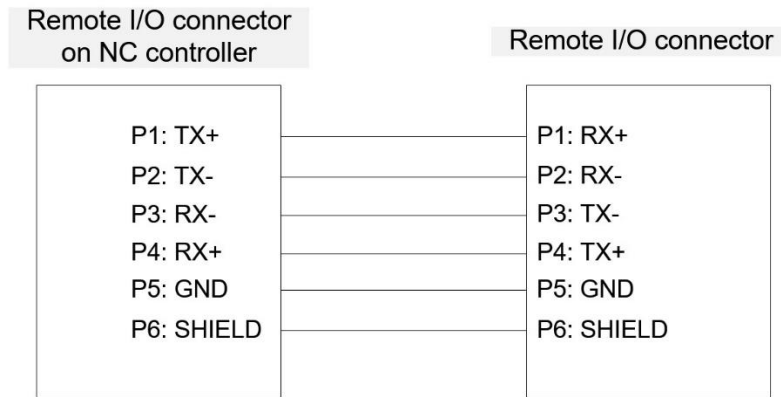



The remote I/O module is mainly divided into two types: optical coupling type and relay type; the definitions of their model names are as follows:

## 3

NC - EIO - T 32 32    

(1)            (2)            (3) (4)    (5) (6)

(1) Series name

(2) Product name

(3) Type:

T: optical coupling type (allowable current: under 50 mA; surge current: under 100 mA).

R: relay type (according to relay specifications; allowable current: 5A or 16A).

(4) Number of available input points for this model

(5) Number of available output points for this model

(6) Allowable current value for this model:

None: 5A (G2R relay)

A: 16A (G2R relay)

B: 16A (IDEC relay)

The remote I/O modules are as follows:

Model	Description	Remark
NC-EIO-R2010	Relay type IO module with 20 input points and 10 output points	G2R relay Allowable current: 5A
NC-EIO-R2010A	Relay type IO module with 20 input points and 10 output points	G2R relay Allowable current: 16A
NC-EIO-R2010B	Relay type IO module with 20 input points and 10 output points	IDEC relay Allowable current: 16A
NC-EIO-R3216	Relay type IO module with 32 input points and 16 output points	G2R relay Allowable current: 5A
NC-EIO-R3216A	Relay type IO module with 32 input points and 16 output points	G2R relay Allowable current: 16A
NC-EIO-R3216B	Relay type IO module with 32 input points and 16 output points	IDEC relay Allowable current: 16A
NC-EIO-R3232	Relay type IO module with 32 input and 32 output points	Allowable current: 5A
NC-EIO-T3232	Optical coupling type IO module with 32 input and 32 output points	Allowable current: 50 mA

**Precautions for wiring the remote I/O module are as follows:**

- (1) The COM point of the input terminal is used for signal current; DC 24V or 0V power input is strictly prohibited.
- (2) Users can choose whether the input signal is H (PNP) or L (NPN) type with the H / L switch according to the specifications of the external sensor. When H (PNP) is selected, the COM point will provide +24V; and when L (NPN) is selected, the COM point will be 0V.

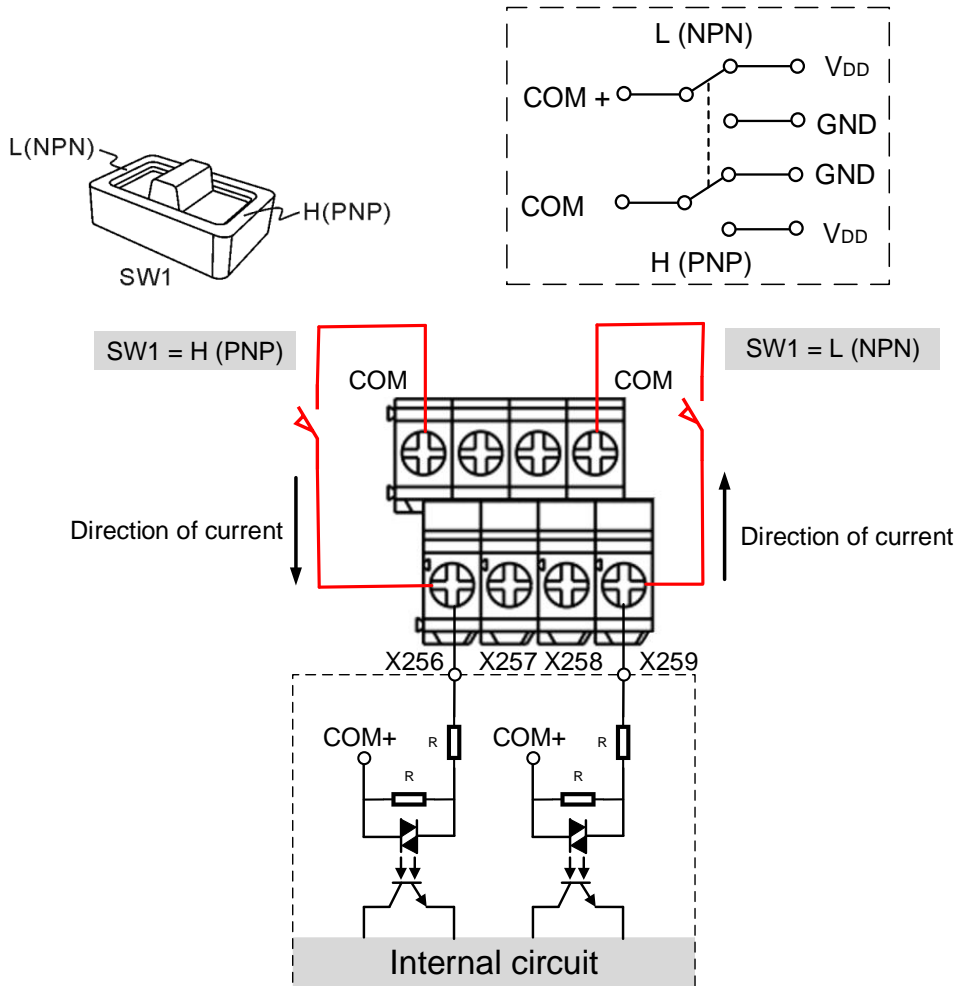

- (3) Up to 8 remote I/O modules can be connected at the same time; the station number of the module can be switched by using the knob on the circuit board. 0 = station 1, 1 = station 2, 2 = station 3 and so on, to a maximum of 7 = station 8.

When the knob of the module is set to 8 (= station 9) and 9 (= station 10), the setting of 8 is regarded as the setting of 0 (= station 1), and the setting of 9 is regarded as the setting of 1 (= station 2). Do not rotate the knob to the same numbers for different modules simultaneously.

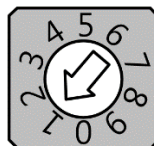

Station number knob

3

3.2.11.1 NC-EIO-R2010

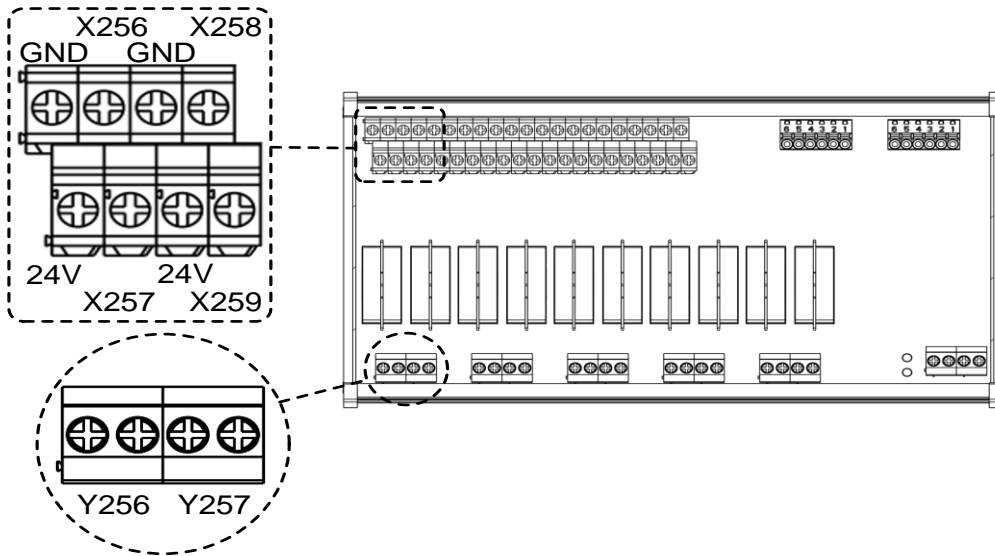

DI wiring example description

Wiring example for the proximity switch of NPN two-wire system:

- (1) Switch the H / L switch to L (NPN), and short-circuit the GND (common specification: blue wire) of the sensor with the GND (0V) of the same power system.
- (2) Simply connect the Vcc (common specification: brown wire) to the input contact.

NPN 2 wire proximity sensor

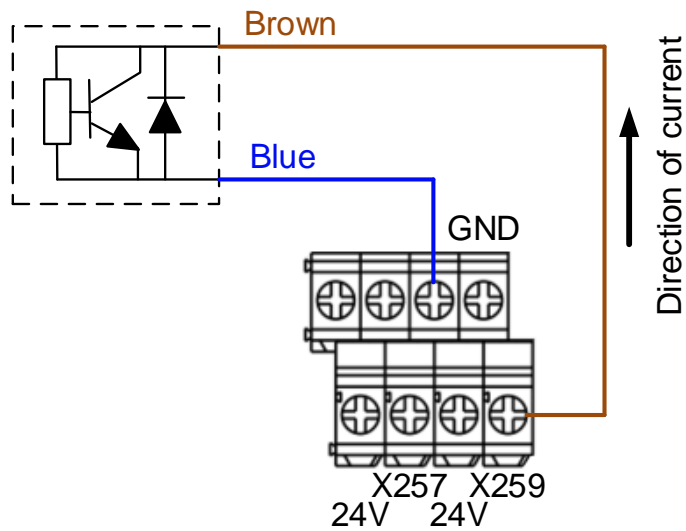

Wiring example for the proximity switch of PNP two-wire system:

- (1) Switch the H / L switch to H (PNP), and short-circuit the Vcc (common specification: brown wire) of the sensor with the +24V of the same power system.
- (2) Simply connect the GND (common specification: blue wire) to the input contact.

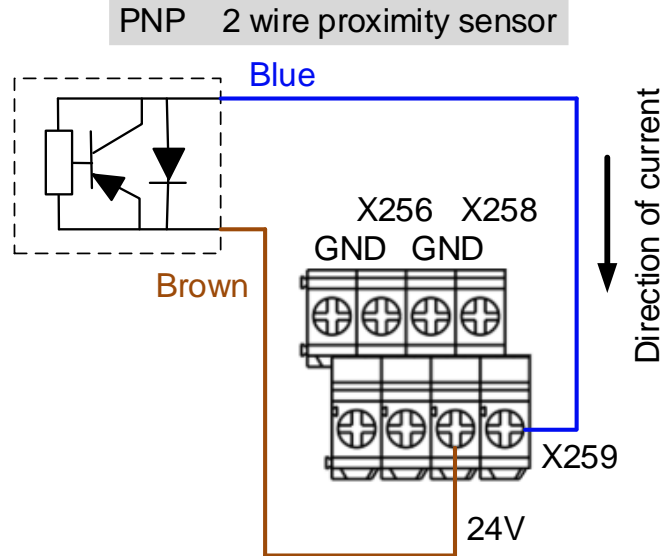

Wiring example for the proximity switch of NPN three-wire system:

- (1) Switch the H / L switch to L (NPN).
- (2) Connect the Vcc (common specification: brown wire) of the sensor to +24V.
- (3) Connect the GND (common specification: blue wire) of the sensor to GND (0V).
- (4) Connect the signal wire (common specification: black wire) of the sensor to the input contact.

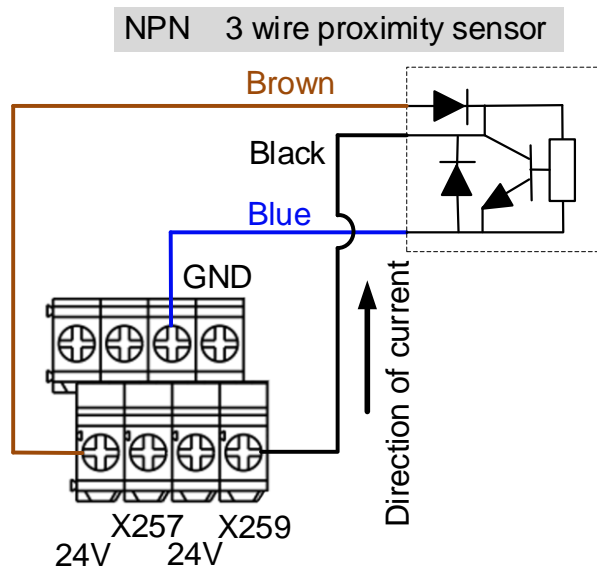

# 3

Input wiring example for the proximity switch of PNP three-wire system:

- (1) Switch the H / L switch to H (PNP).
- (2) Connect the Vcc (common specification: brown wire) of the sensor to +24V.
- (3) Connect the GND (common specification: blue wire) of the sensor to GND (0V).
- (4) Connect the signal wire (common specification: black wire) of the sensor to the input contact.

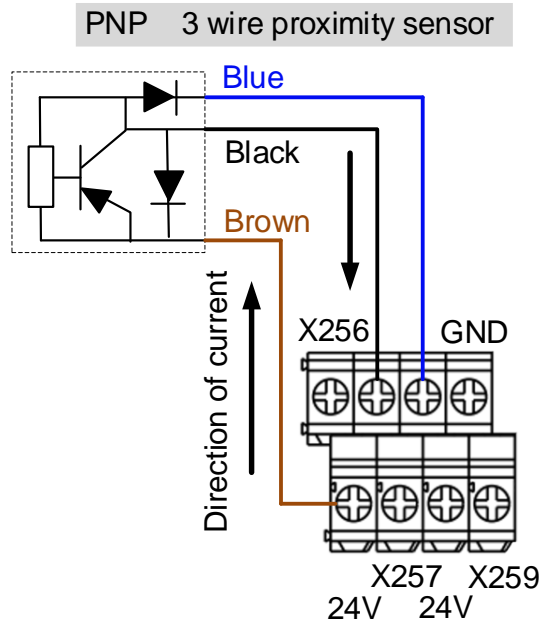

Output wiring example description:

The output contacts of the remote I/O module are in pairs; please use them as dry contacts.

- (1) Connect +24V to one of the output contacts, and the other contact will be DO.
- (2) Connect DO to the Vcc (+) of the external device, and connect the GND (-) of the external device to the 0V of the external power to form a circuit.
- (3) When the controller sets the output contact to on, the circuit is closed and the device will start operating.

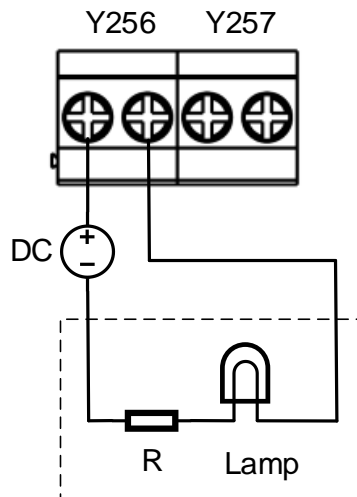

3.2.11.2 NC-EIO-R3216

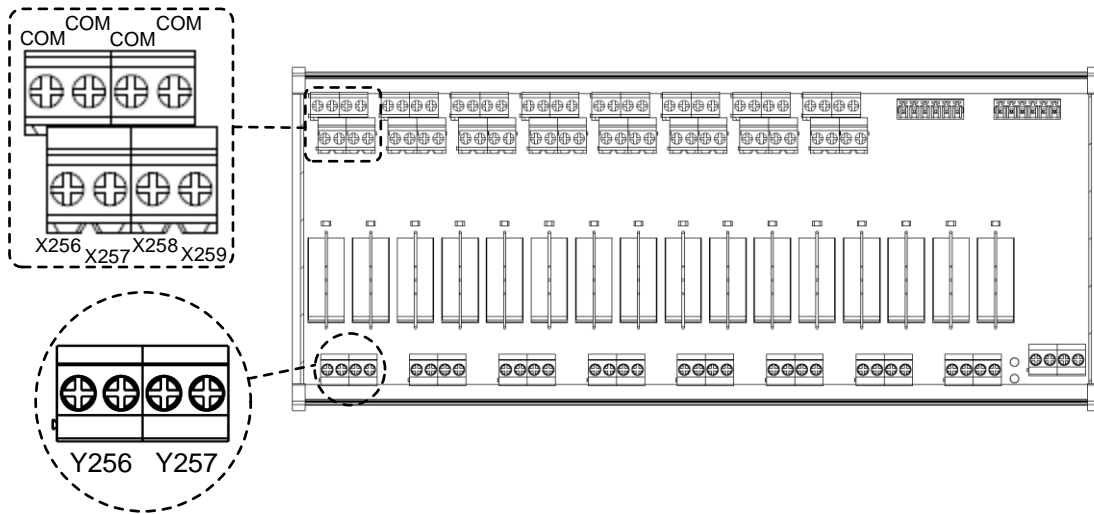

**DI wiring example description:**

Proximity switch of NPN two-wire system:

- (1) Switch the H / L switch to L (NPN), the COM point will provide 0V, connect the GND (common specification: blue wire) of the sensor with COM, or short-circuit the GND of the sensor with the GND (0V) of the same power system.
- (2) Simply connect the Vcc (common specification: brown wire) to the input contact.

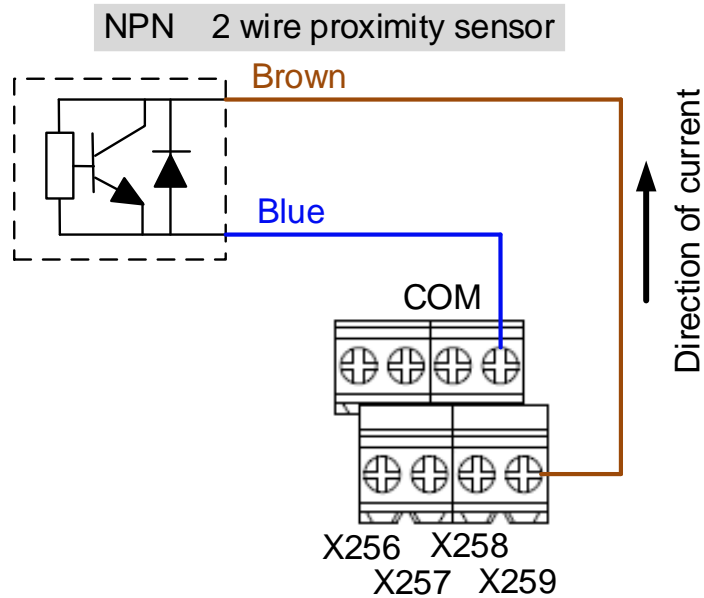

3

Proximity switch of PNP two-wire system:

- (1) Switch the H / L switch to H (PNP), the COM point will provide +24V; connect the Vcc (common specification: brown wire) of the sensor with COM, or short-circuit the Vcc of the sensor with the +24V of the same power system.
- (2) Simply connect the GND (common specification: blue wire) to the input contact.

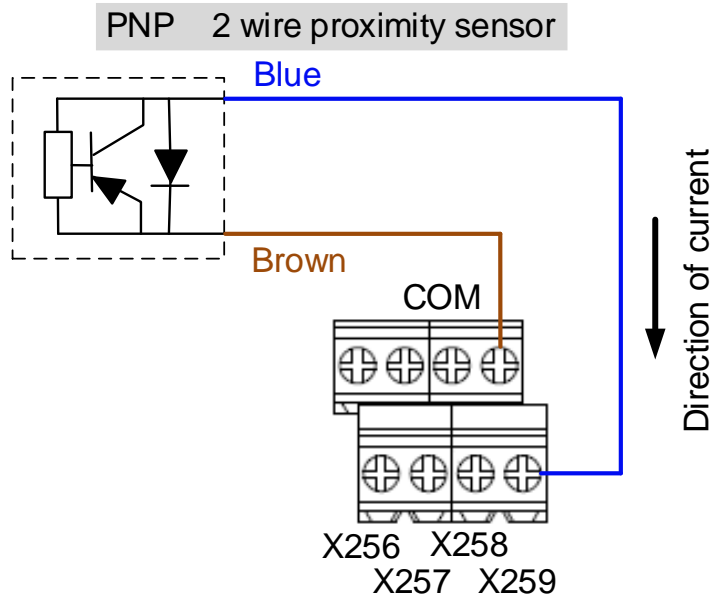

Input wiring example for the proximity switch of NPN three-wire system:

- (1) Switch the H / L switch to L (NPN).
- (2) Connect the Vcc (common specification: brown wire) of the sensor to +24V.
- (3) Connect the GND (common specification: blue wire) of the sensor to COM (0V).
- (4) Connect the signal wire (common specification: black wire) of the sensor to the input contact.

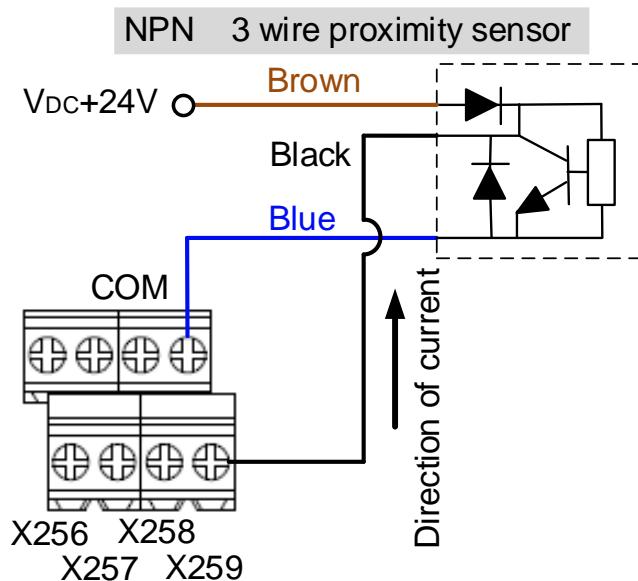

Input wiring example for the proximity switch of PNP three-wire system:

- (1) Switch the H / L switch to H (PNP).
- (2) Connect the Vcc (common specification: brown wire) of the sensor to +24V.
- (3) Connect the GND (common specification: blue cable) of the sensor to 0V.
- (4) Connect the signal wire (common specification: black wire) of the sensor to the input contact.

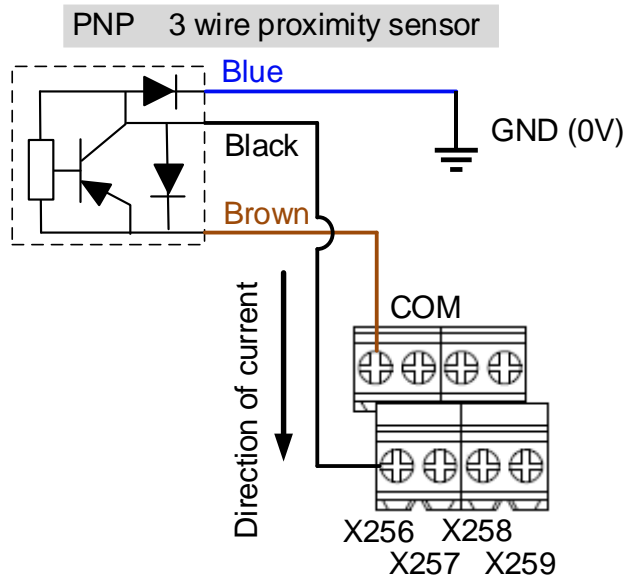

Output wiring example description:

The output contacts of the remote I/O module are in pairs; please use them as dry contacts.

- (1) Connect +24V to one of the output contacts, and the other contact will be DO.
- (2) Connect DO to the Vcc (+) of the external device, and connect the GND (-) of the external device to the 0V of the external power to form a circuit.
- (3) When the controller sets the output contact to on, the circuit is closed and the device will start operating.

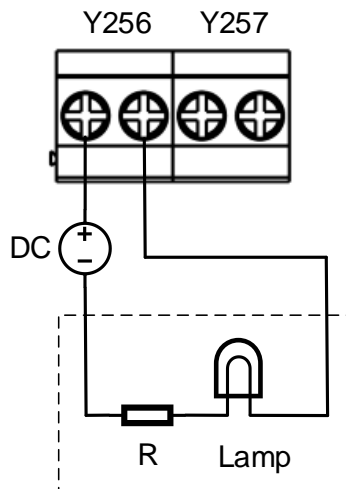



3

3.2.11.3 NC-EIO-R3232

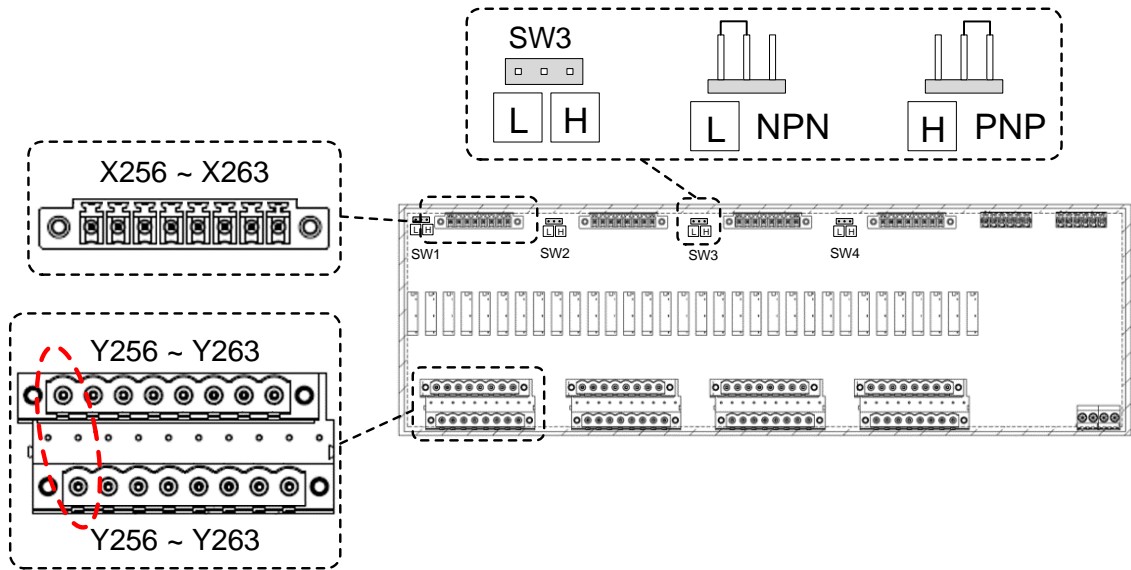

Wiring example for the proximity switch of NPN two-wire system:

- (1) Switch the short circuit jumper to L (NPN), and short-circuit the GND (common specification: blue wire) of the sensor with the GND (0V) of the same power system.
- (2) Simply connect the Vcc (common specification: brown wire) to the input contact.

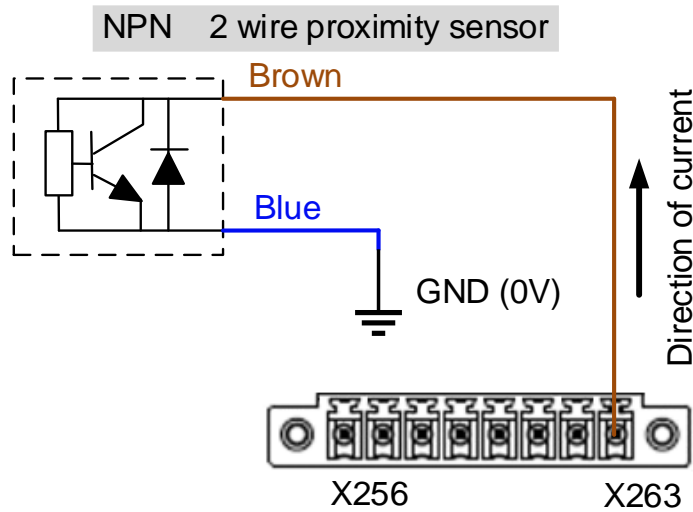

Wiring example for the proximity switch of PNP two-wire system:

- (1) Switch the short circuit jumper to H (PNP), and short-circuit the Vcc (common specification: brown wire) of the sensor with the +24V of the same power system.
- (2) Simply connect the GND (common specification: blue wire) to the input contact.

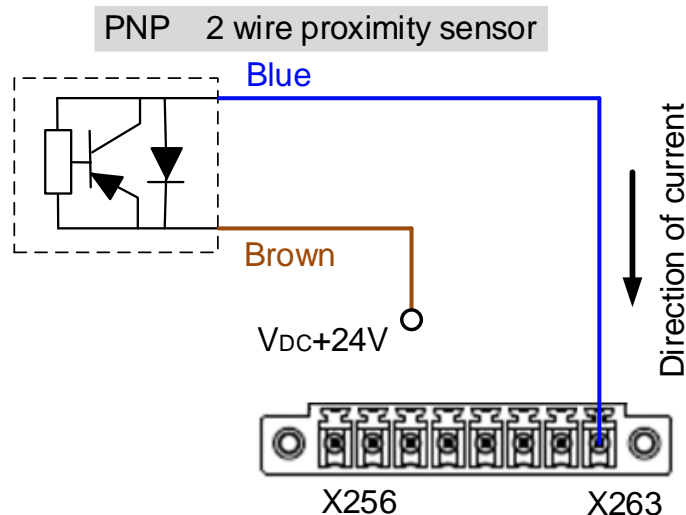

Input wiring example for the proximity switch of NPN three-wire system:

- (1) Switch the short circuit jumper to L (NPN).
- (2) Connect the Vcc (common specification: brown wire) of the sensor to +24V (same power system).
- (3) Connect the GND (common specification: blue wire) of the sensor to 0V (same power system).
- (4) Connect the signal wire (common specification: black wire) of the sensor to the input contact.

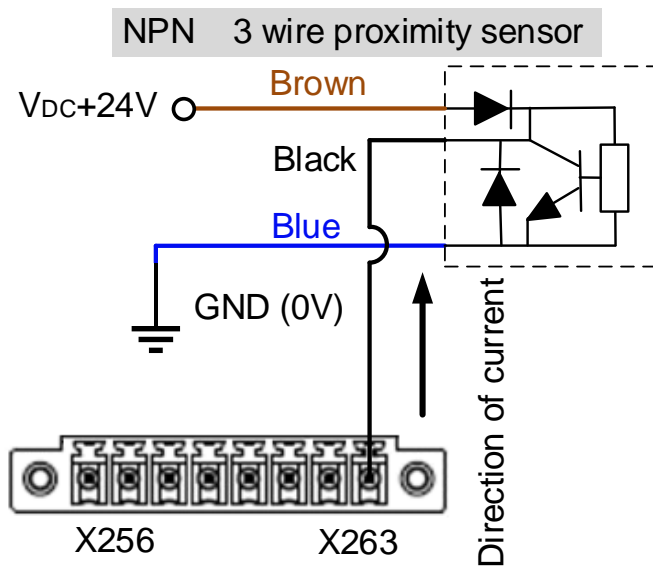

3

Input wiring example for the proximity switch of PNP three-wire system:

- (1) Switch the short circuit jumper to H (PNP).
- (2) Connect the Vcc (common specification: brown wire) of the sensor to +24V (same power system).
- (3) Connect the GND (common specification: blue wire) of the sensor to 0V (same power system).
- (4) Connect the signal wire (common specification: black wire) of the sensor to the input contact.

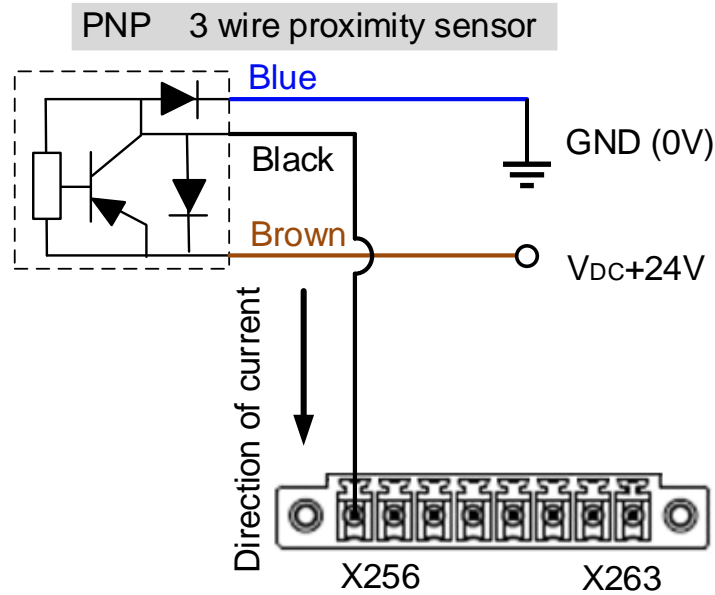

Output wiring example description:

The output contacts of the remote I/O module are in pairs; please use them as dry contacts.

- (1) Connect +24V to one of the output contacts, and the other contact will be DO.
- (2) Connect DO to the Vcc (+) of the external device, and connect the GND (-) of the external device to the 0V of the external power to form a circuit.
- (3) When the controller sets the output contact to on, the circuit is closed and the device will start operating.

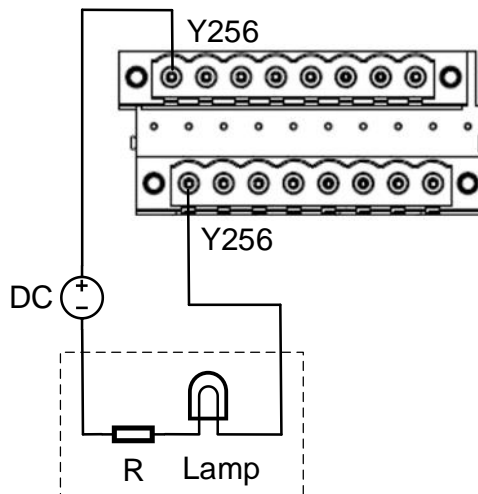

3.2.11.4 NC-EIO-T3232

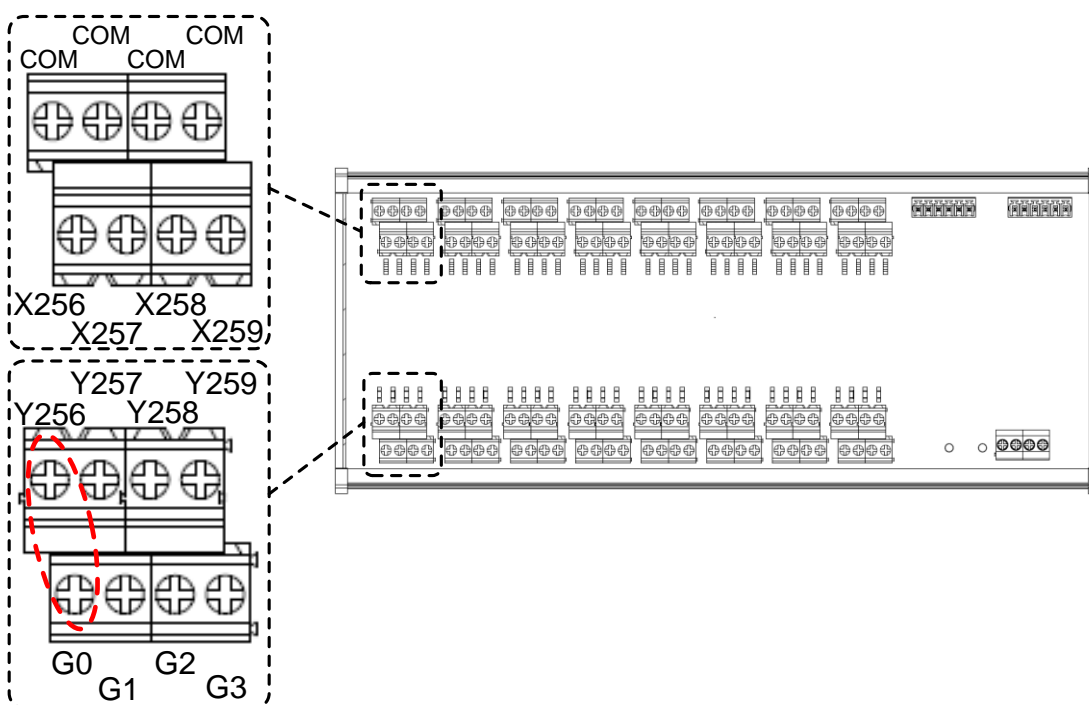

DI wiring example description:

Proximity switch of NPN two-wire system:

- (1) Switch the H / L switch to L (NPN), the COM point will provide 0V; connect the GND (common specification: blue wire) of the sensor with COM, or short-circuit the GND of the sensor with the GND (0V) of the same power system.
- (2) Simply connect the Vcc (common specification: brown wire) to the input contact.

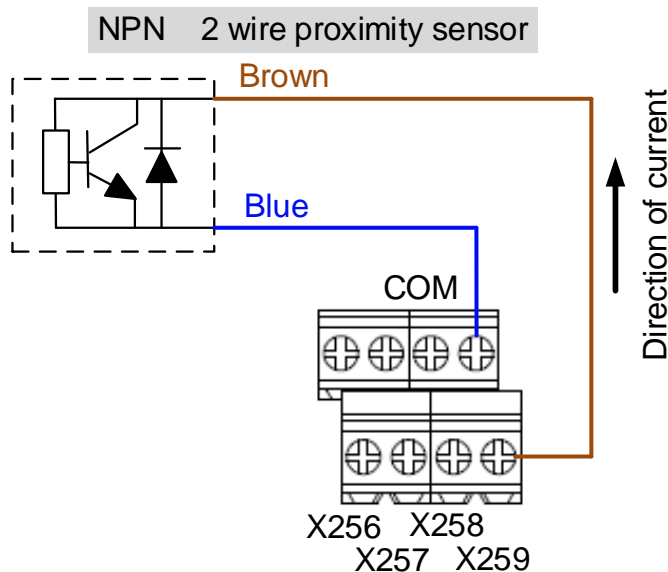

3

Proximity switch of PNP two-wire system:

- (1) Switch the H / L switch to H (PNP), the COM point will provide +24V; connect the Vcc (common specification: brown wire) of the sensor with COM, or short-circuit the Vcc of the sensor with the +24V of the same power system.
- (2) Simply connect the GND (common specification: blue wire) to the input contact.

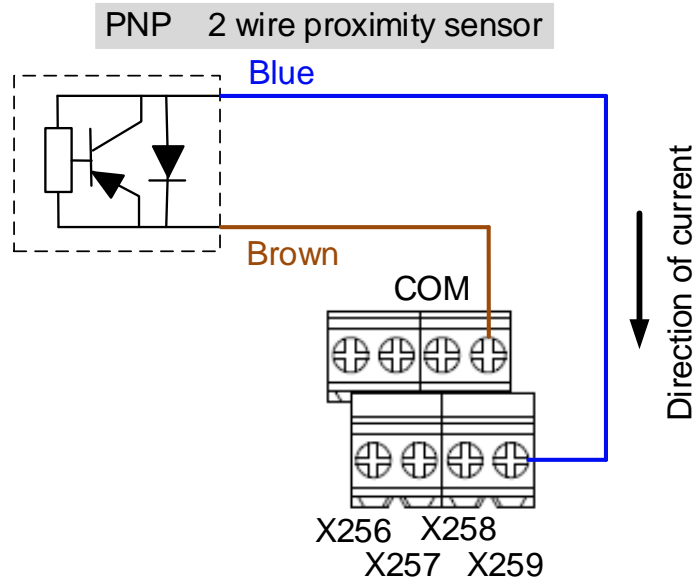

Input wiring example for the proximity switch of NPN three-wire system:

- (1) Switch the H / L switch to L (NPN).
- (2) Connect the Vcc (common specification: brown wire) of the sensor to +24V.
- (3) Connect the GND (common specification: blue wire) of the sensor to 0V.
- (4) Connect the signal wire (common specification: black wire) of the sensor to the input contact.

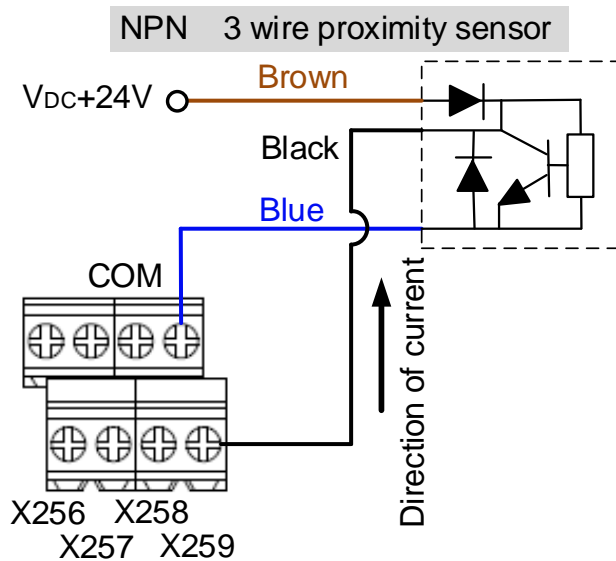

Input wiring example for the proximity switch of PNP three-wire system:

- (1) Switch the H / L switch to H (PNP).
- (2) Connect the Vcc (common specification: brown wire) of the sensor to +24V.
- (3) Connect the GND (common specification: blue wire) of the sensor to 0V.
- (4) Connect the signal wire (common specification: black wire) of the sensor to the input contact.

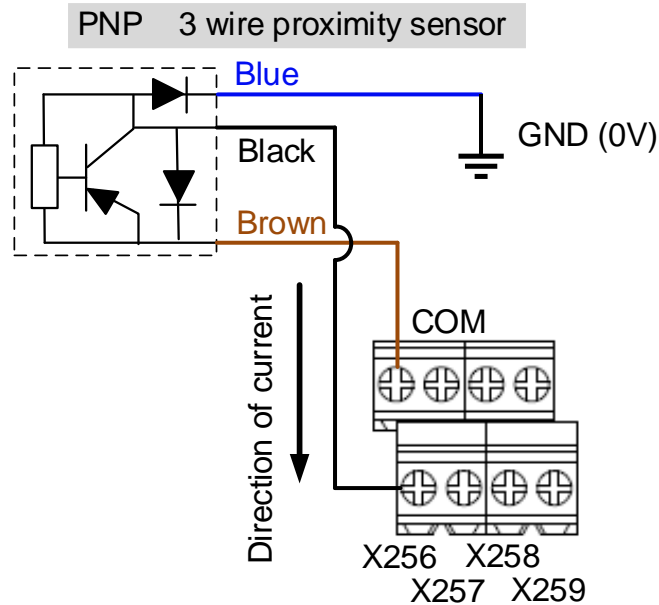

Output wiring example description:

The output contacts of the remote I/O module are in pairs; please use them as dry contacts.

- (1) Connect 0V to one of the output contacts, and the other contact will be DO.
- (2) Connect DO to the GND (-) of the external device, and connect the Vcc (+) of the external device to the +24V of the external power to form a circuit.
- (3) When the controller sets the output contact to on, the circuit is closed and the device will start operating.

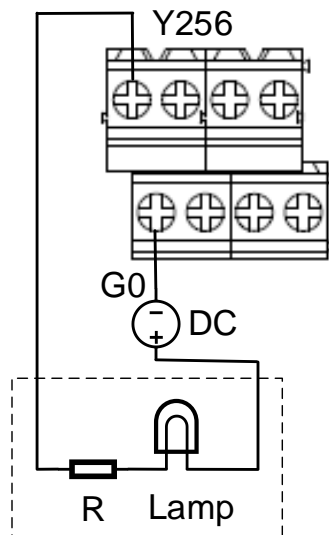

3

### 3.2.12 Wiring for local I/O connector

For providing a more flexible I/O configuration, some B series NC controllers have external I/O connectors.

Pin assignment for B series NC3□□ models

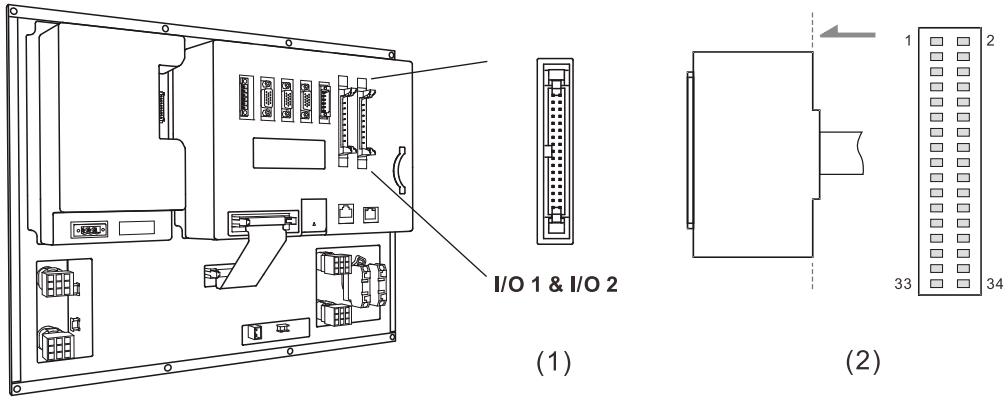

(1) Local I/O connector (female); (2) Local I/O connector (male)

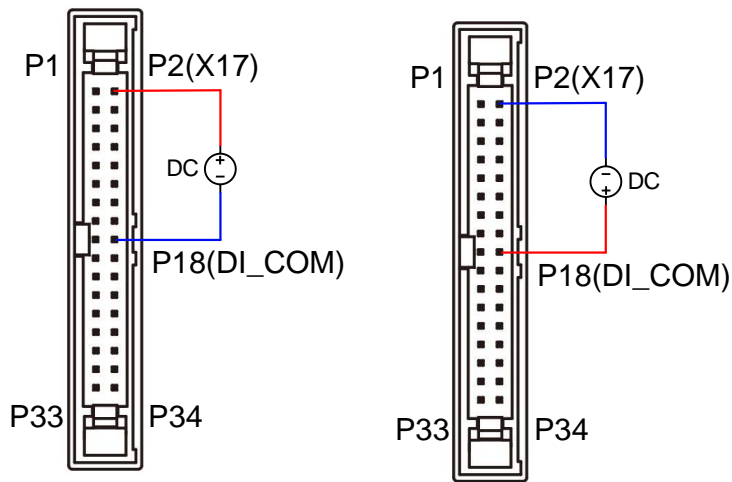

DI wiring for local I/O

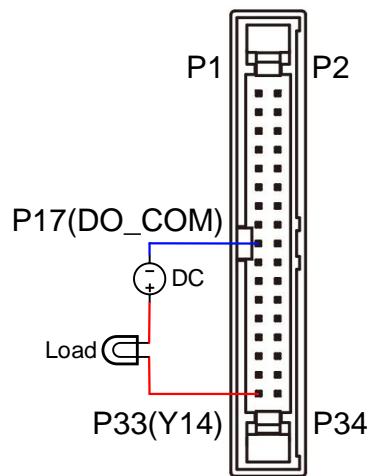

DO wiring for local I/O

I/O 1			
Pin 1	X0	Pin 2	X1
Pin 3	X2	Pin 4	X3
Pin 5	X4	Pin 6	X5
Pin 7	X6	Pin 8	X7
Pin 9	X8	Pin 10	X9
Pin 11	X10	Pin 12	X11
Pin 13	X12	Pin 14	X13
Pin 15	X14	Pin 16	X15
Pin 17	DO_COM	Pin 18	DI_COM
Pin 19	Y0	Pin 20	Y1
Pin 21	Y2	Pin 22	Y3
Pin 23	Y4	Pin 24	Y5
Pin 25	Y6	Pin 26	Y7
Pin 27	Y8	Pin 28	Y9
Pin 29	Y10	Pin 30	Y11
Pin 31	Y12	Pin 32	Y13
Pin 33	Y14	Pin 34	Y15

I/O 2			
Pin 1	X16	Pin 2	X17
Pin 3	X18	Pin 4	X19
Pin 5	X20	Pin 6	-
Pin 7	-	Pin 8	-
Pin 9	-	Pin 10	-
Pin 11	-	Pin 12	-
Pin 13	-	Pin 14	-
Pin 15	-	Pin 16	-
Pin 17	DO_COM	Pin 18	DI_COM
Pin 19	Y16	Pin 20	Y17
Pin 21	Y18	Pin 22	Y19
Pin 23	Y20	Pin 24	-
Pin 25	-	Pin 26	-
Pin 27	-	Pin 28	-
Pin 29	-	Pin 30	-
Pin 31	-	Pin 32	-
Pin 33	-	Pin 34	-



# 3

## Pin assignment for B series NC200 models

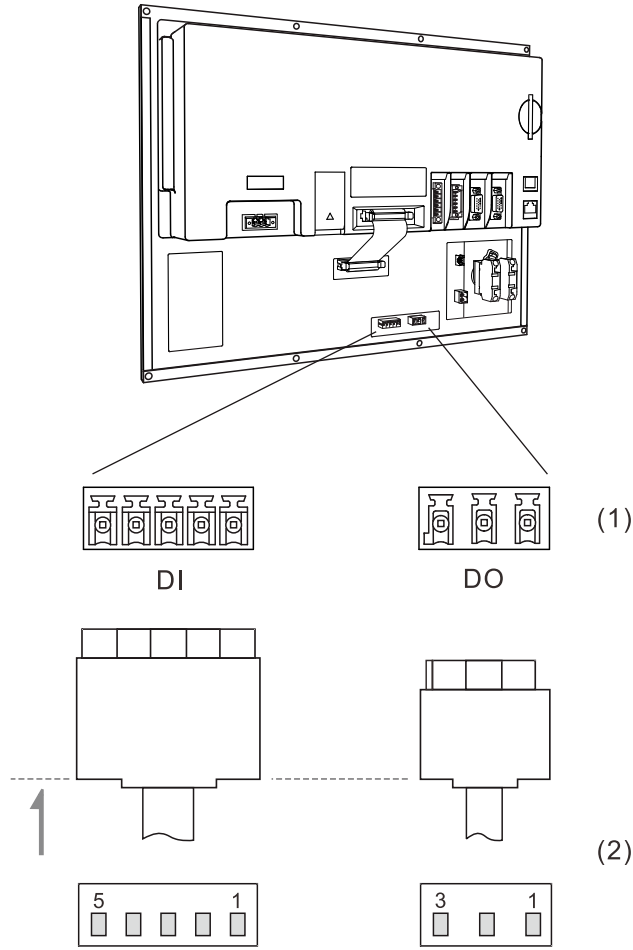

(1) Local I/O connector (female); (2) Local I/O connector (male)

DI			
Pin 1	X112	Pin 2	X113
Pin 3	X114	Pin 4	X115
Pin 5	X116	-	-

DO			
Pin 1	Y112	Pin 2	Y113
Pin 3	Y114	-	-

DI wiring; connect to an external power supply.

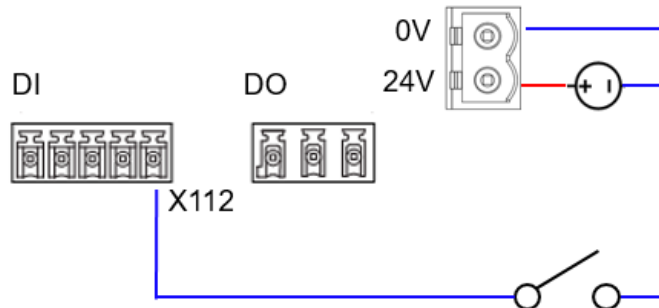

Note: 24V power must be supplied to the machine operation panel B.

DO wiring; connect to an external power supply.

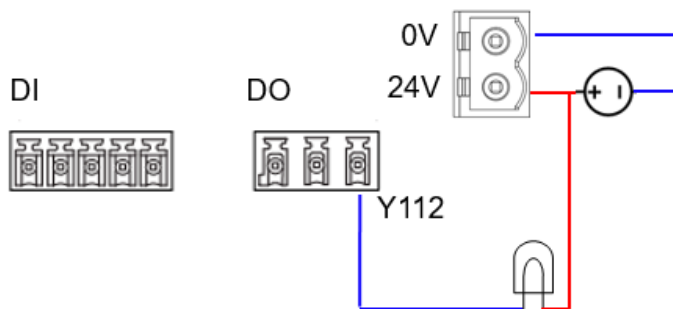

Note: 24V power must be supplied to the machine operation panel B.

Pin assignment for OPEN CNC series models

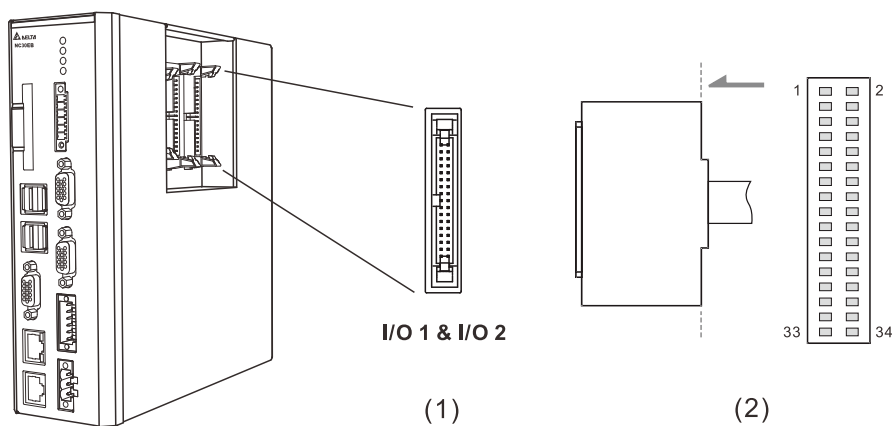

(1) Local I/O connector (female); (2) Local I/O connector (male)

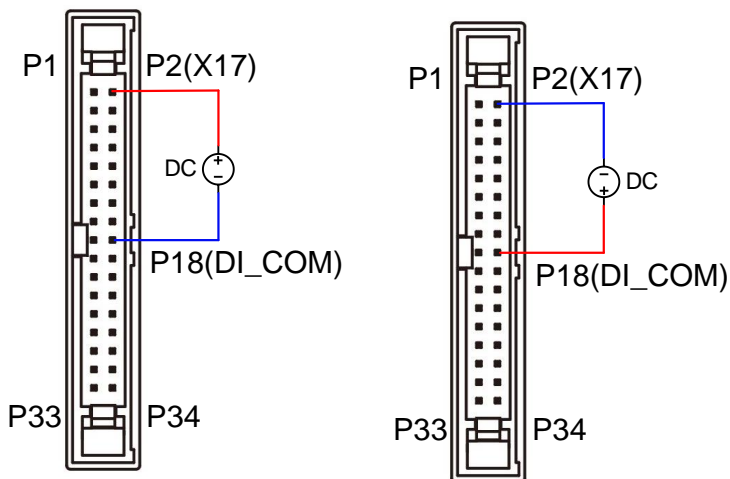

DI wiring for local I/O

# 3

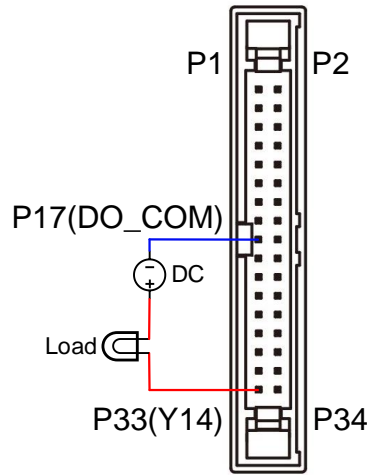

DO wiring for local I/O

I/O 1				I/O 2			
Pin 1	X0	Pin 2	X1	Pin 1	X16	Pin 2	X17
Pin 3	X2	Pin 4	X3	Pin 3	X18	Pin 4	X19
Pin 5	X4	Pin 6	X5	Pin 5	X20	Pin 6	X21
Pin 7	X6	Pin 8	X7	Pin 7	X22	Pin 8	X23
Pin 9	X8	Pin 10	X9	Pin 9	X24	Pin 10	X25
Pin 11	X10	Pin 12	X11	Pin 11	X26	Pin 12	X27
Pin 13	X12	Pin 14	X13	Pin 13	X28	Pin 14	X29
Pin 15	X14	Pin 16	X15	Pin 15	X30	Pin 16	X31
Pin 17	DO_COM	Pin 18	DI_COM	Pin 17	DO_COM	Pin 18	DI_COM
Pin 19	Y0	Pin 20	Y1	Pin 19	Y16	Pin 20	Y17
Pin 21	Y2	Pin 22	Y3	Pin 21	Y18	Pin 22	Y19
Pin 23	Y4	Pin 24	Y5	Pin 23	Y20	Pin 24	Y21
Pin 25	Y6	Pin 26	Y7	Pin 25	Y22	Pin 26	Y23
Pin 27	Y8	Pin 28	Y9	Pin 27	Y24	Pin 28	Y25
Pin 29	Y10	Pin 30	Y11	Pin 29	Y26	Pin 30	Y27
Pin 31	Y12	Pin 32	Y13	Pin 31	Y28	Pin 32	Y29
Pin 33	Y14	Pin 34	Y15	Pin 33	Y30	Pin 34	Y31

### 3.2.13 Wiring for I/O connector on machine operation panel B of NC3□□ series models

NC-PAN-300BM-PS

3

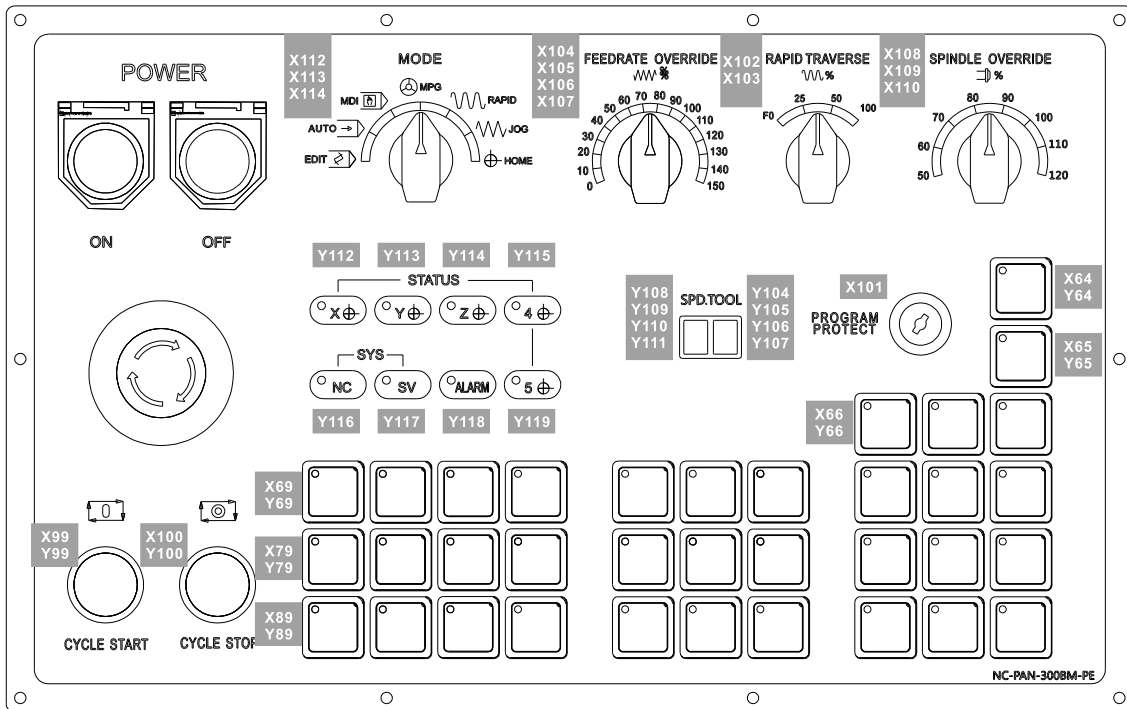

NC-PAN-301BM-PS

3

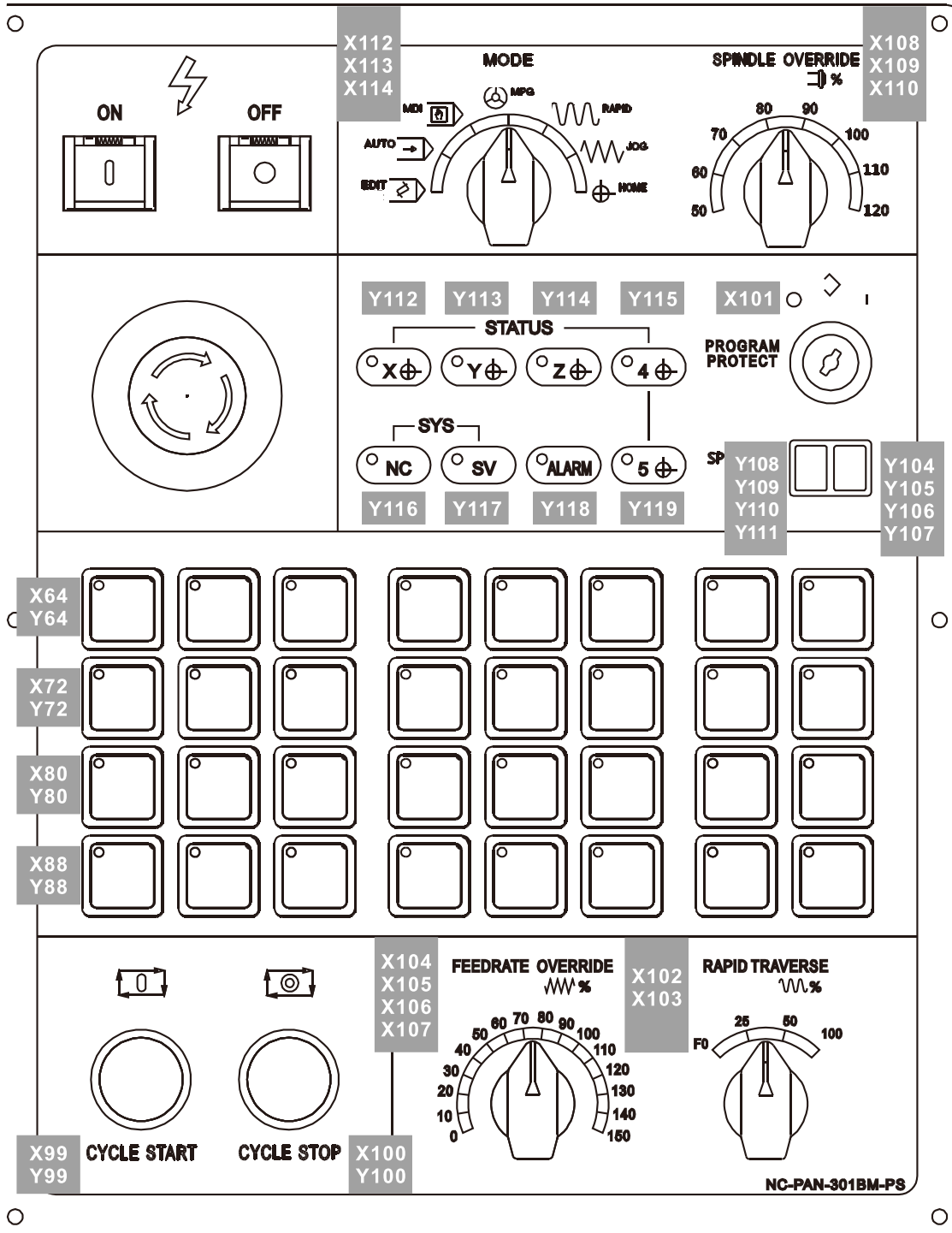

NC-PAN-310BM-PE

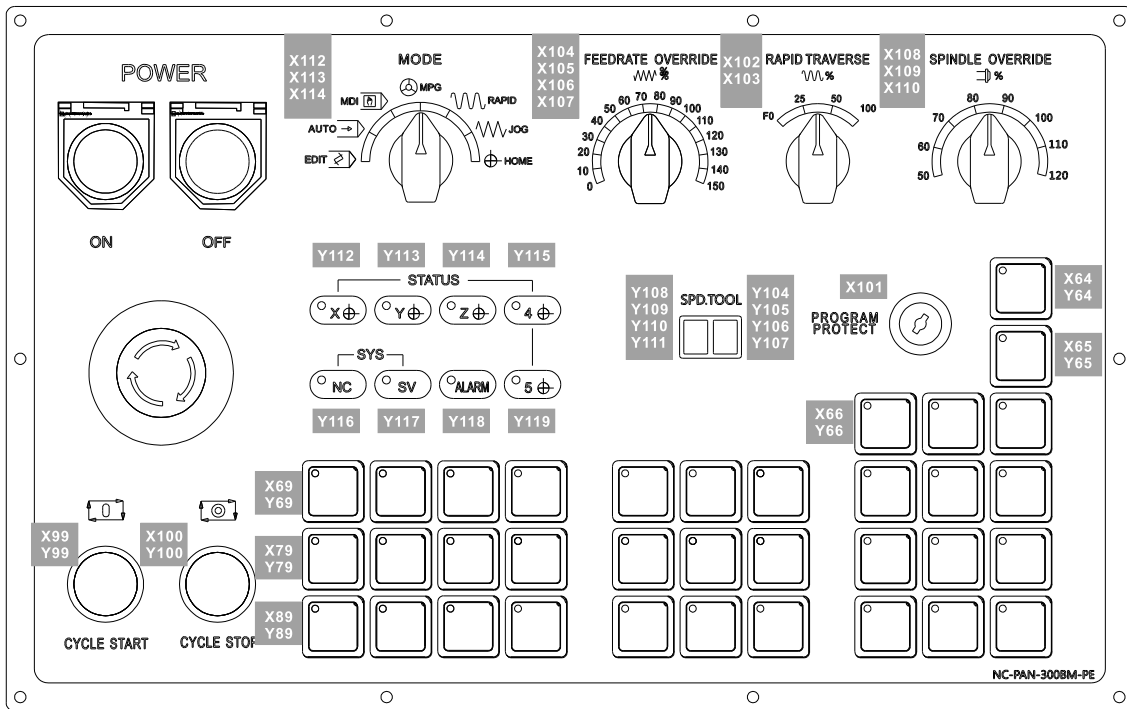

3

NC-PAN-310BM-PE

3

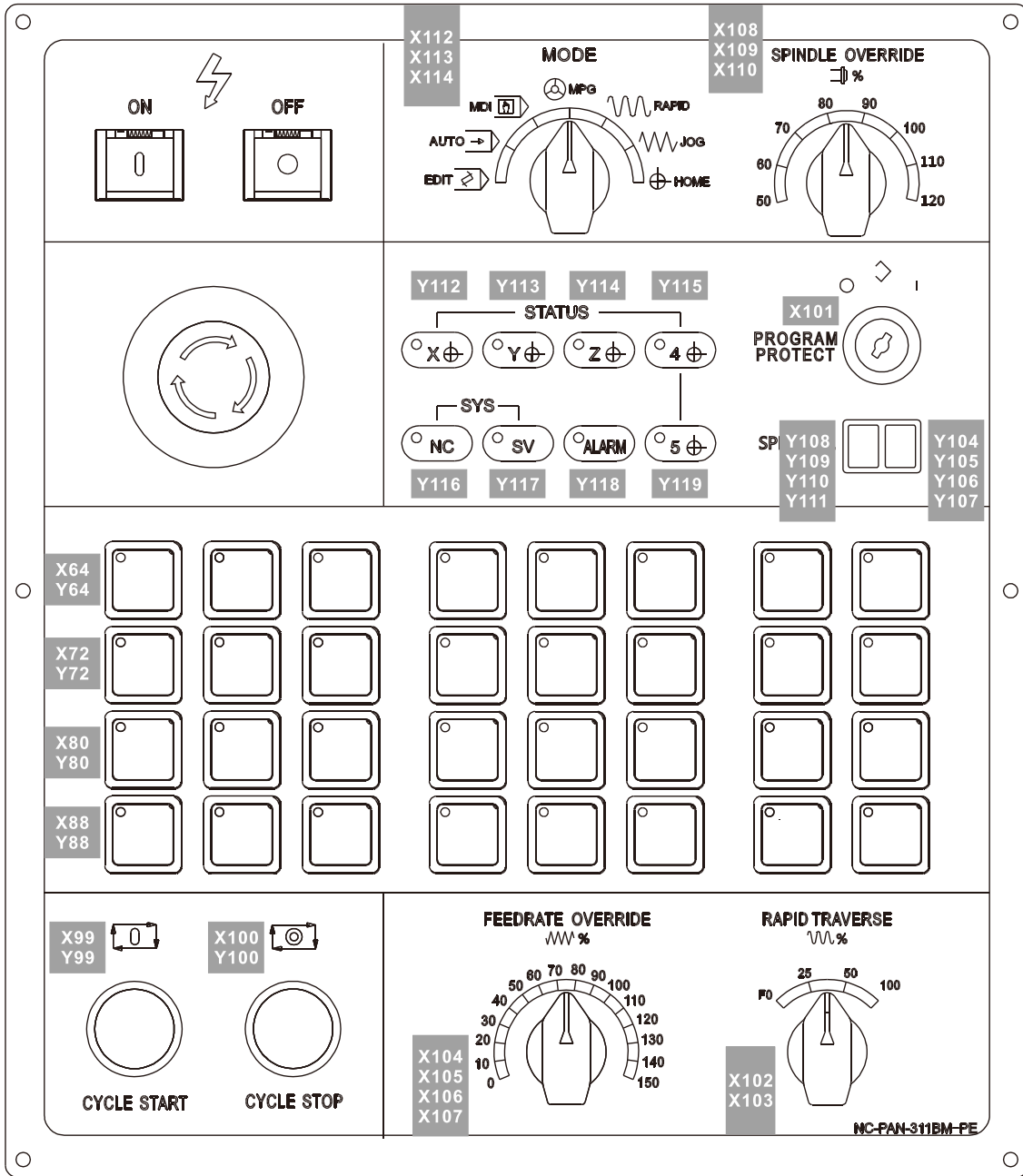

NC-PAN-311BM-PE

Wiring of the Power On / Power Off switches

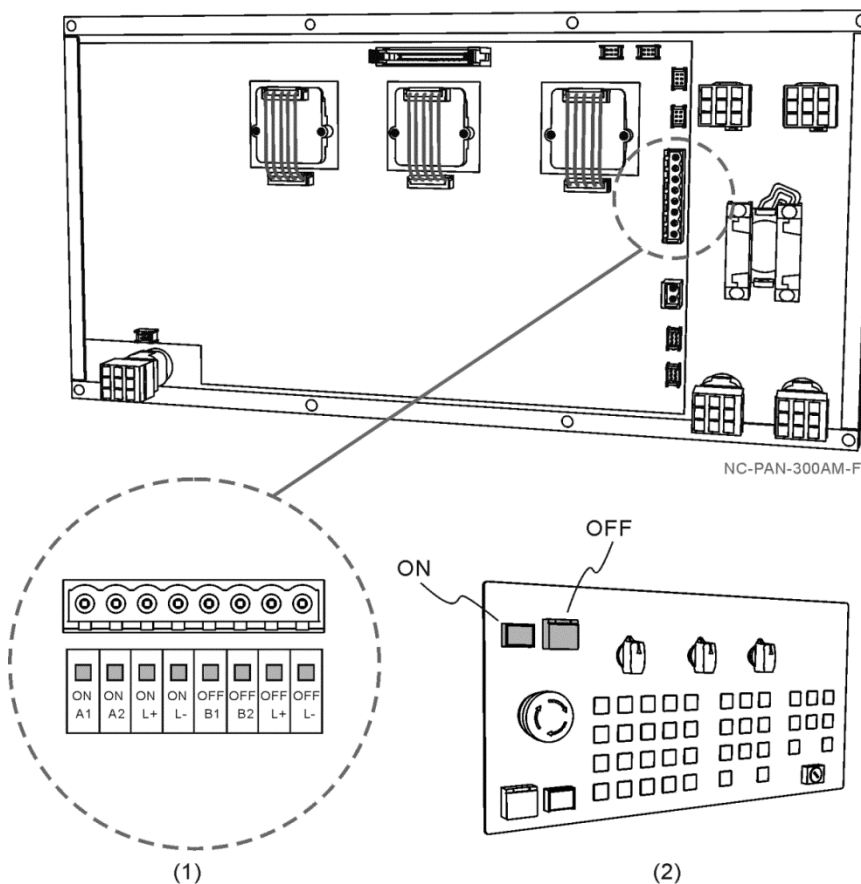

Description of the connector

The power indicator requires a 24 V<sub>DC</sub> system; to light up the Power On indicator, +24 V<sub>DC</sub> power must be inputted to the ONL+ pin and 0V must be inputted to the ONL- pin; to light up the Power Off indicator, +24 V<sub>DC</sub> must be inputted to the OFFL+ pin and 0V must be inputted to the OFFL- pin.

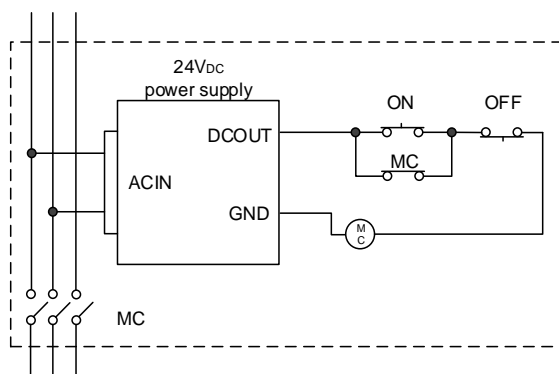

When the Power On key is pressed, the circuit between ONA1 and ONA2 is closed; when the Power Off key is pressed, the circuit between OFFB1 and OFFB2 is open.



(This page is intentionally left blank.)

# 3

# Table of Group Function

# 4

This chapter provides tables of group function for you to quickly view all of the functions of the NC series controller.



4.1	System group function table .....	4-2
4.2	Machine operation panel A - function of keys.....	4-11
4.3	Machine operation panel B - function of keys .....	4-13
4.4	Table of corresponding buttons (for OPENCNC models).....	4-15

4

4.1 System group function table

Available in all modes

Position (POS) function			
Layer 1	Layer 2	Layer 3	Layer 4
ABS (absolute coordinates)	-	-	-
REL (the clear function of the corresponding axis is available only when you connect the axis)	CLR ALL	-	-
	CLR X	-	-
	CLR Y	-	-
	CLR Z	-	-
	CLR A	-	-
	CLR B	-	-
CLR C	-	-	-
MECH (machine coordinates)	-	-	-

EDIT mode

Program (PRG) function_File manage			
Layer 1	Layer 2	Layer 3	Layer 4
COPY F	-	-	-
PASTE	-	-	-
DEL (file / folder)	-	-	-
SEL TOGL / CANCEL	-	-	-
ALL SEL TOGL / CANCEL	-	-	-
File Manage	-	-	-
SORT	NAME	-	-
	SIZE	-	-
	DATE	-	-
NEW F	-	-	-
FOLDER	-	-	-
RENAME	-	-	-
FIND F	-	-	-
MERGE	-	-	-
MACRO	-	-	-
INT MRO	-	-	-
DXF	Transform	-	-

EDIT mode

PRG_File edit				
Layer 1	Layer 2	Layer 3	Layer 4	
File edit	COPY	-	-	
	PASTE	-	-	
	DEL	-	-	
	UNDO	-	-	
	B START	-	-	
	B END	-	-	
	LABLE	-	-	
	STRING		NEXT	-
			PREV	-
			REPLACE	-
		Replace all	-	

AUTO mode

PRG			
Layer 1	Layer 2	Layer 3	Layer 4
SF set	-	-	-
START	RUN	-	-
BARCODE	LOAD	-	-
	CLEAR	-	-
	CLEAR ALL	-	-
FILE QUEUE	LOAD	-	-
	MODE CHG	-	-
	CLEAR ALL	-	-
	ADD FILE	-	-
	MOVE	-	-
	DISP CHG	-	-
File Manage	→	-	-
	←	-	-
	SEL TOGL	-	-
	ALL SEL TOGL	-	-
	DEL	-	-
	RENAME	-	-
	FOLDER	-	-
	SORT	-	-

4

JOG / MPG mode - Program edit

PRG			
Layer 1	Layer 2	Layer 3	Layer 4
SF set	-	-	-
TEACH	POSITION	-	-
	LINEAR	-	-
	CIRCULAR	P1	-
		P2	-
		P3	-
	DEL	-	-
	SAVE	-	-
	NEW FILE	-	-
SET	-	-	

MDI mode - Program edit

PRG			
Layer 1	Layer 2	Layer 3	Layer 4
LOAD	-	-	-
SAVE	-	-	-
CLEAR	-	-	-

HOME mode - Program edit

PRG			
Layer 1	Layer 2	Layer 3	Layer 4
SF set	-	-	-

Available in all modes

OFS			
Layer 1	Layer 2	Layer 3	Layer 4
COORD	AUTO	CLR REL	-
		CLR ALL	-
		SET L	-
		SET L/2	Point1
			Point2
			SET
	SET P	-	
	ABS	-	-
	INC	-	-
	SQUARE	X1	-
		X2	-
		Y1	-
		Y2	-
		SET	-
		Z	-
	CIRCLE	P1	-
		P2	-
		P3	-
		SET	-
		Z	-

OFS				
Layer 1	Layer 2	Layer 3	Layer 4	
CUTTER	ABS	-	-	
	INC	-	-	
	SET H	-	-	
	CLEAR		H/D	-
			WEAR	-
			LIFE	-
			ALL	-
MAGA	MAGA1 (functions is Layer 3 are only available in JOG mode)	SET	-	
		RST ALL	-	
		LOCK	-	
		UNLOCK	-	
	MAGA2 (functions is Layer 3 are only available in JOG mode)		SET	-
			RST ALL	-
			LOCK	-
			UNLOCK	-
MACRO	LOCAL	-	-	
	GLOBAL	-	-	
	HOLD	-	-	
	EXTEND	-	-	
	MECH	-	-	
	ABS	-	-	

Available in all modes

GRA			
Layer 1	Layer 2	Layer 3	Layer 4
CENT SET	-	-	-
WIN RST	-	-	-
WIN SET	UP	-	-
	DOWN	-	-
	LEFT	-	-
	RIGHT	-	-
	ZM IN	-	-
	ZM OUT	-	-
	OK	-	-
	CANCEL	-	-
X-Y / Y-Z / X-Z / X-Y-Z	-	-	-
GRAPHIC	-	-	-
PREVIEW (AUTO mode only)	-	-	-
CLEAR	-	-	-

Available in all modes

ALM			
Layer 1	Layer 2	Layer 3	Layer 4
ALARM	-	-	-
HISTORY	CLR ALL	-	-

Available in all modes

4

DGN			
Layer 1	Layer 2	Layer 3	Layer 4
PROCESS	SET NR	-	-
	CLR TIME	-	-
	CLR NR	-	-
USR VAR	USR VAR	DEL	-
		US DEC	-
		HEX	-
		S DEC	-
		FLOAT	-
	SYS VAR	-	-
	M VAR	DEL	-
		US DEC	-
		HEX	-
		S DEC	-
FLOAT		-	
MLC	BIT	X	-
		Y	-
		M	-
		A	-
		T	-
		C	-
	REG	US DEC	-
		HEX	-
		S DEC	-
		FLOAT	-
	DEV MON	US DEC	-
		HEX	-
		S DEC	-
		FLOAT	-
	EDITOR (EDIT mode only)	LD	-
		LDI	-
		LDP	-
		LDF	-
		OUT	-
		APP	-
		—	-
			-
		DEL V-LN	-
ADD LN		-	
DEL LN		-	
DEL		-	
LABEL	-		
TABLE	-		

DGN			
Layer 1	Layer 2	Layer 3	Layer 4
MLC	EDITOR	SYMBOL	X
			Y
			M
			A
			T
			C
			D
			P
			I
			DEL
			COPY
			PASTE
			SAVE
	IMPORT	IMPORT	
	EXPORT	EXPORT	
		NEW FILE	
	JUMP TO	-	
	SELECT	-	
	CUT	-	
	COPY	-	
PASTE	-		
SET (EDIT mode only)	ON	-	
	OFF	-	
	RUN/STP	-	
JUMP TO	-	-	
SYS MON	SRV MON	-	-
	I/O MON	-	-
	SYS VAR	-	-
	VAR MON	SYS VAR	-
		CH VAR	-
		AXIS VAR	-
		IF VAR	-
		MLC VAR	-
		US DEC	-
		BIN	-
		HEX	-
S DEC	-		
STATUS	SYSTEM	-	-
	FW SN	-	-
	HW SN	-	-
	M INFO	DEL	-

4



4

DGN				
Layer 1	Layer 2	Layer 3	Layer 4	
PWD	S SCP	LOCK / UNLOCK	-	
		SYS CHK	-	
	M SCP	PWD CHG	-	
		LOCK / UNLOCK	-	
		RST U1	-	
		RST U2	-	
		FUN ENA	OK	
			CANCEL	
			DEFAULT	
	RESET	-		
	U1 SCP	PWD CHG	-	
		LOCK / UNLOCK	-	
	U2 SCP	PWD CHG	-	
		LOCK / UNLOCK	-	
	EXPIRE	SETTING	-	
		RELEASE	-	
EXP SCP		PWD CHG		
		LOCK / UNLOCK		
TUNING (JOG or MPG mode only)	NEXT AX	-	-	
	READ	-	-	
	COMPUTE	-	-	
	WR GAIN	-	-	
	WR Notch	-	-	
	RUN	-	-	
	JOG←	-	-	
	JOG→	-	-	
	POS1	-	-	
	POS2	-	-	
	TAP RIV	TAP SET(1)		
		TAP SET(2)		
	SERVO	READ	-	
	SYN MOV	POS SET	-	
TEXT WR	-	-	-	
IMPORT	-	-	-	
EXPORT	EXPORT	-	-	
	SEL ALL	-	-	
	CLR ALL	-	-	
LOGO WR	-	-	-	

Available in all modes

Parameter (PAR) function			
Layer 1	Layer 2	Layer 3	Layer 4
PROCESS	-	-	-
OPERATE	-	-	-
MAGA	-	-	-
SPINDLE	-	-	-
MACHINE	-	-	-
HOME	-	-	-
ETH.	DEFAULT	-	-
COMP	OK	-	-
	um	-	-
	um+	-	-
	IMPORT	-	-
	IMPORT+	-	-
SYSTEM	DEFAULT	-	-
	COLOR	-	-
MLC	DEFAULT	-	-
	COLOR	-	-
GRAPHIC	DEFAULT	-	-
	COLOR	-	-
SERVO	READ	-	-
SEARCH	-	-	-
CONFIG (except AUTO and MDI modes)	OK	-	-
SET RIO (except AUTO and MDI modes)	OK	-	-
PAR GRP	SAVE	-	-
	DEL PAR	-	-
	DEL GRP	-	-
	WRT PAR	-	-
	RED PAR	-	-
	SRT PAR	-	-
	AVERAGE	-	-

4















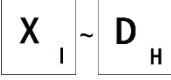

Available in all modes

Software (SOFT) function (without physical panel)				
Panel functions	Program execution	MPG simulation	Tool magazine forward	Spindle forward
	Stop execution	Machine lock	Tool magazine backward	Spindle stop
	Single block execution	Program preview	Chip discharge conveyor forward	Spindle reverse
	Optional stop	Machine lock	Chip discharge conveyor reverse	-
	Single block skip	Z axis lock	Air blow	Spindle positioning
	Coolant	Light	Program protect	Limit release
Magnification adjustment	Increase progressively	-	-	-
	Decrease progressively	-	-	-
	100%	-	-	-
	0%	-	-	-
Axis operation	X←	-	-	-
	X→	-	-	-
	Y↗	-	-	-
	Y↘	-	-	-
	Z↑	-	-	-
	Z↓	-	-	-



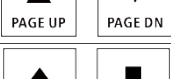
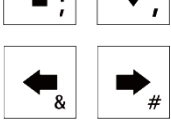



Available in all modes

Software (SOFT) function (with physical panel)			
Layer 1	Layer 2	Layer 3	Layer 4
Panel functions	Program preview	Chip discharge conveyor forward	-
	Function lock	Chip discharge conveyor reverse	-
	Z axis lock	Automatic shutdown	-
	Machine lock	Program protect	-
	Spindle positioning	Customization 1	-
	Air blow	Customization 2	-















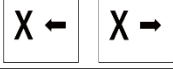
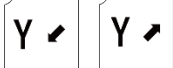

## 4.2 Machine operation panel A - function of keys

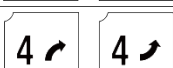
Symbol	Description	Supported mode / group
	The POS group key. Press to display the screen of coordinate setting.	All modes and groups
	The PRG group key. Press to display the screen of program editing.	All modes and groups
	The OFS group key. Press to display the screen of coordinate setting and tool offset setting.	All modes and groups
	The DGN group key. Press to display the screen of diagnosis, system parameter, and system status.	All modes and groups
	The ALM group key. Press to display the screen of alarm display.	All modes and groups
	The GRA group key. Press to display the screen of graphic display.	All modes and groups
	The PAR group key. Press to display the screen of parameter setting.	All modes and groups
	The SOFT group key. Press to display the configured panel screen.	All modes and groups
	Reset key	All modes and groups
	Axis position and command code keys	PRG
	Numeric keys (operation symbols)	PRG, OFS, DGN
	Decimal point key (operation symbol)	PRG, OFS
	Negative sign key (operation symbol)	PRG, OFS
	PAGE UP and PAGE DN (page down) keys	PRG, OFS, DGN
	Cursor keys (operation symbols)	PRG, OFS, DGN
	Home (end) key	PRG
	Space key	PRG
	Shift key	PRG
	Delete (insert) key	PRG



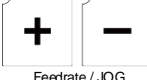
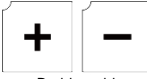
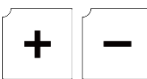



## 4

Symbol	Description	Supported mode / group
	Back space key	PRG
	Enter key	PRG, OFS, DGN
	Exit key	PRG, DGN
	Parentheses key	PRG
	Left and right function keys	All modes and groups
	Function keys	All modes and groups

### 4.3 Machine operation panel B - function of keys

Symbol	Description
	AUTO mode: for program execution
	EDIT mode: for file management and program editing
	JOG mode: for manual operation of the machine tool
	MPG mode: for operating the axis direction of the machine tool with the MPG
	MDI mode: for simple program input and execution
	Home mode: for rapid homing to the machine origin
	Rapid traverse mode: executes axis movements according to the set rapid override
	X axis direction: in JOG mode, manually operate the X axis towards positive or negative direction
	Y axis direction: in JOG mode, manually operate the Y axis towards positive or negative direction
	Z axis direction: in JOG mode, manually operate the Z axis towards positive or negative direction
	Rotation axis direction: in JOG mode, manually operate the rotation axis in forward or reverse direction
	Spindle forward: manually run the spindle in forward direction
	Spindle stop: manually stop the spindle rotation
	Spindle reverse: manually run the spindle in reverse direction
 Feedrate / JOG	Feedrate / JOG override: increment / decrement
 Rapid override	Rapid override: increment / decrement
 Spindle override	Spindle override: increment / decrement
	Single block execution: execute one single block at a time and then stop
	Limit cancellation: the operation key for clearing the alarm when the limit protection is triggered
	Single block skip: skip one single block when there is a "/" symbol in the block

## 4

Symbol	Description
	Tool magazine forward: press this button to rotate the tool magazine for one position in the forward direction
	Tool magazine reverse: press this button to rotate the tool magazine for one position in the reverse direction
	Optional stop: stop at the specified block if there is an M01 command in the block
	MPG simulation: during program execution, enable this function to control the execution speed with MPG
	Coolant switch: coolant ON / coolant OFF
	Light switch: light ON / light OFF

#### 4.4 Table of corresponding buttons (for OPENCNC models)

NC key	PC keyboard	Description
F1 - F8 (Function Key)	F1 - F8	Function keys
▶ (Function Key)	Tab	Next page (of the function bar)
◀ (Function Key)	Ctrl + Tab	Previous page (of the function bar)
POS	Ctrl + F1	The POS group key
PRG	Ctrl + F2	The PRG group key
OFS	Ctrl + F3	The OFS group key
DGN	Ctrl + F4	The DGN group key
ALM	Ctrl + F5	The ALM group key
GRA	Ctrl + F6	The GRA group key
PAR	Ctrl + F7	The PAR group key
SOFT	Ctrl + F8	The SOFT group key
Numeric keys	Numeric keys	-
Alphabetic keys	Alphabetic keys	-
Symbol keys	Symbol keys	-
Direction keys	Direction keys	-
PAGE UP / PAGE DN	Page Up / Page Down	-
BACK SPACE	Backspace	-
SPACE	Space	-
DEL / INS	Delete / Insert	-
SHIFT	Shift	-
HOME / END	Home / End	-
ENTER	Enter	-
EXIT	Esc	-
RESET	Ctrl + Esc	-
-	F12	Help (function descriptions for keys)
SHIFT + GRA	\	Screen capturing



(This page is intentionally left blank.)

4

# Introduction to NC System Modes

# 5

This chapter introduces the seven system modes supported by the NC controller.

5.1 Auto mode (AUTO).....	5-2
5.2 Program edit mode (EDIT) .....	5-2
5.3 Manual input mode (MDI).....	5-2
5.4 MPG mode (MPG).....	5-2
5.5 Jog mode (JOG) .....	5-3
5.6 Rapid mode (RAPID) .....	5-3
5.7 Homing mode (HOME) .....	5-3
5.8 Group screen overview.....	5-4

## 5

### 5.1 Auto mode (AUTO)

To execute a program, you have to open the file, switch the system to AUTO mode, and then press **CYCLE START**. In this mode, you can verify the machining program, cutting conditions, and position coordinates before execution as well as avoid unexpected execution by accidentally pressing **CYCLE START** in other modes. This mode is only for program execution rather than program editing or manual axis movement.

### 5.2 Program edit mode (EDIT)

You can edit a program in EDIT mode. In this mode, the editing functions in PRG group are available for you to edit the program. In addition, program execution and manual axis movement are not available in this mode.

### 5.3 Manual input mode (MDI)

In MDI mode, you can enter and execute a single block of program in the PRG group screen. In this mode, you can enter up to 14 program blocks in the PRG screen. General program editing, program execution, and manual axis operation are not available in this mode.

### 5.4 MPG mode (MPG)

In MPG mode, you can use the external MPG to manually operate the axes promptly and accurately. Program editing, program execution, and jog operation are not available in this mode.

## 5.5 Jog mode (JOG)

In JOG mode, press the axis direction keys on machine operation panel B to have the axes jog. Set the jog speed and moving distance with the JOG override key. You can move the work platform in high speed with the rapid traverse override key and axis direction keys; the axis moving speed is determined by the rapid override setting. Program execution and editing are not available in this mode.

## 5.6 Rapid mode (RAPID)

When in JOG mode, pressing **RAPID** during operation can switch the JOG speed to the set rapid traverse override.

## 5.7 Homing mode (HOME)

In HOME mode, you can return the axes to the machine origin by simply pressing the corresponding axis direction keys on machine operation panel B. After restarting the controller, you should set the system to HOME mode to have each axis return to the machine origin before executing the program. If you do not perform homing after starting the controller, program execution is prohibited.

# 5

## 5.8 Group screen overview

A full range of information is provided on the screens of function groups of this controller. The following introduces some functions in the group screens.

### ■ Position (POS) group

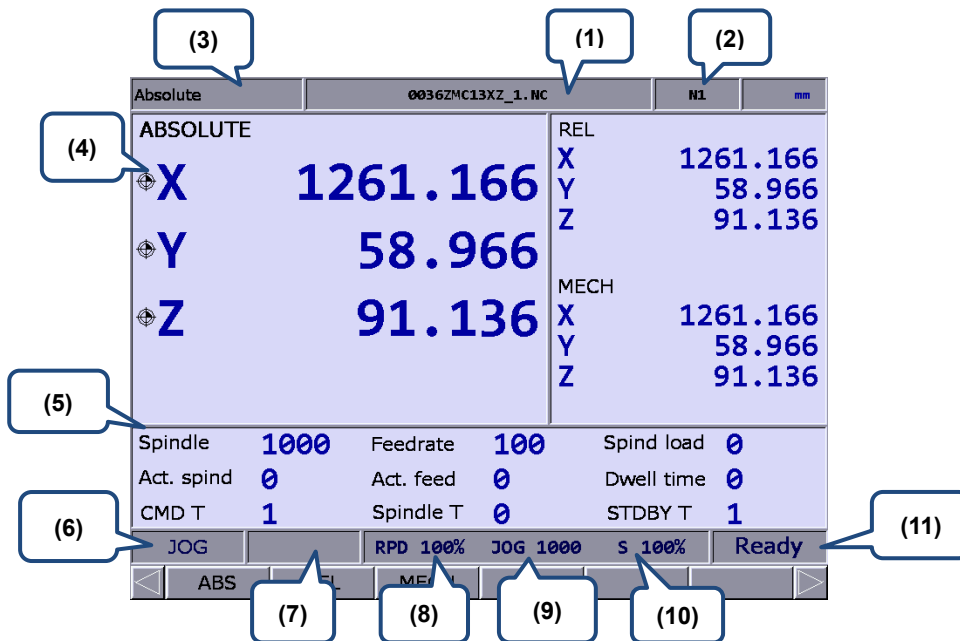

Figure 5.8.1

- |  |                             |
|--|-----------------------------|
| (1) Name of current program                            | (6) Current system mode     |
| (2) Currently executed program line                    | (7) Alarm display           |
| (3) Current group function                             | (8) Rapid traverse override |
| (4) Current coordinates                                | (9) Feedrate override       |
| (5) Machining information:                             | (10) Spindle override       |
| Spindle speed: command value                           | (11) System status          |
| Cutting feedrate: command value                        |                             |
| Spindle load rate: %                                   |                             |
| Actual speed: rpm                                      |                             |
| Actual feedrate: mm/min                                |                             |
| Dwell time: G-code dwell time                          |                             |
| Command tool number: tool number specified in G-code   |                             |
| Spindle tool number: number of the tool on the spindle |                             |
| Standby tool number: system standby tool number        |                             |

(11) displays the current status of the system for your reference. There are 7 system statuses with the display priority as follows: MLC stop > SV NO RDY (servo not ready) > Emg Stop (emergency stop) > PROC (in progress) > RUN (in execution) > STOP (program stops) > Ready.

■ Program (PRG) group

AUTO mode:

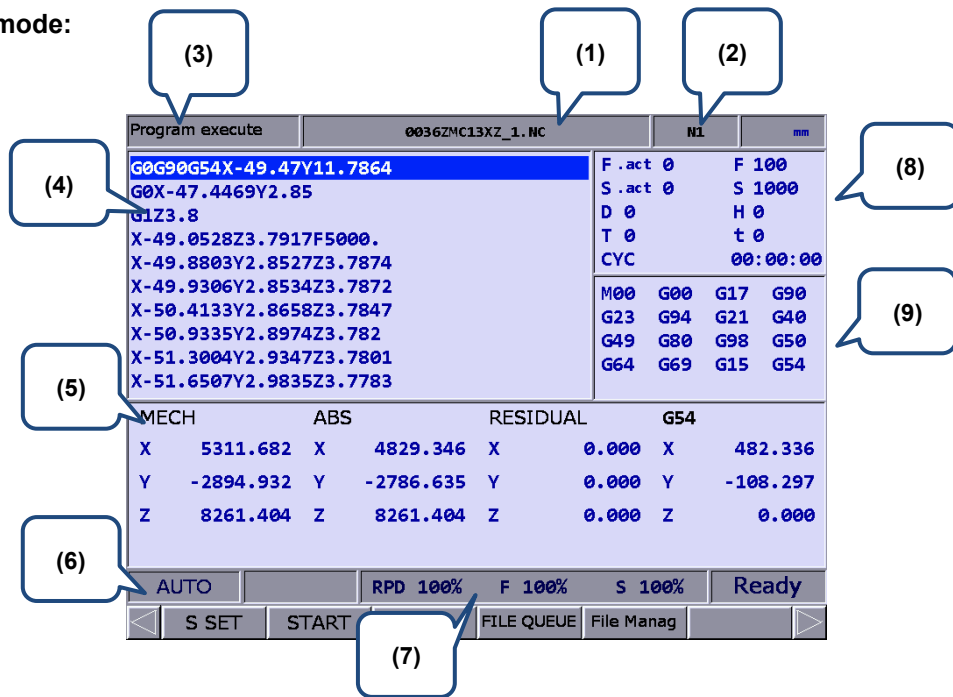

Figure 5.8.2

- (1) Name of current program
- (2) Currently executed program line
- (3) Current group function
- (4) Currently executed program content
- (5) Coordinate information during program execution
- (6) Current system mode
- (7) Current override settings
- (8) F.act: actual feedrate  
S.act: actual spindle speed  
D: tool radius compensation number  
H: tool length compensation number  
T: tool number  
F: feedrate  
S: spindle speed  
t: dwell time  
CYC: cycle time
- (9) Current command status

EDIT mode:

5

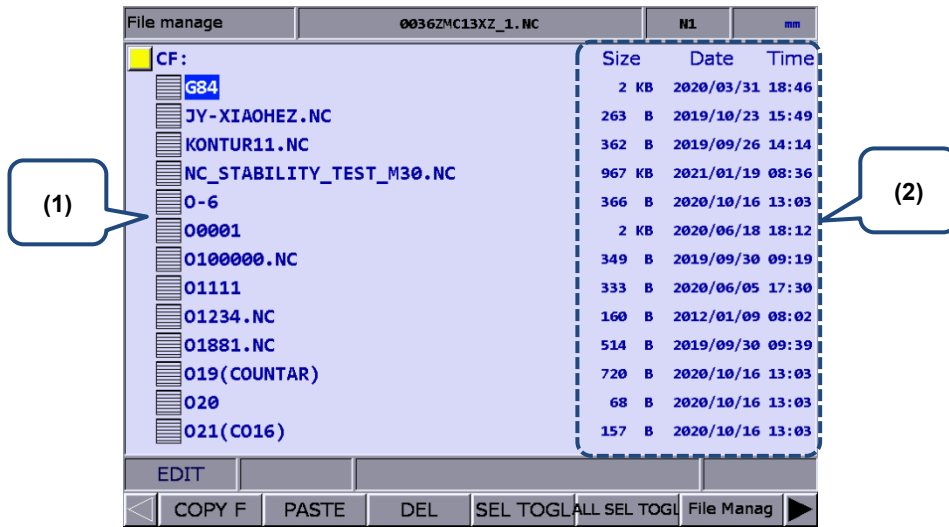

Figure 5.8.3

- (1) File list: displays folders and program files
- (2) File information: displays the size and modification date and time of the file or folder

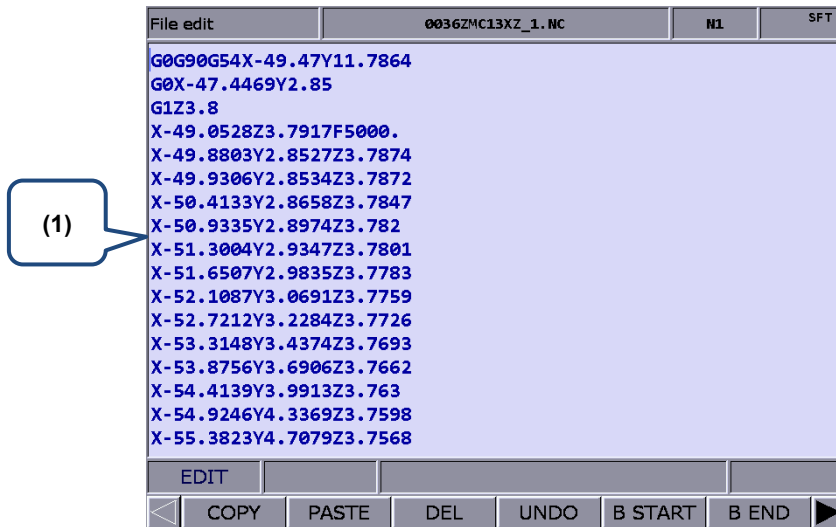

Figure 5.8.4

- (1) File content: displays the content of the program file

MDI mode

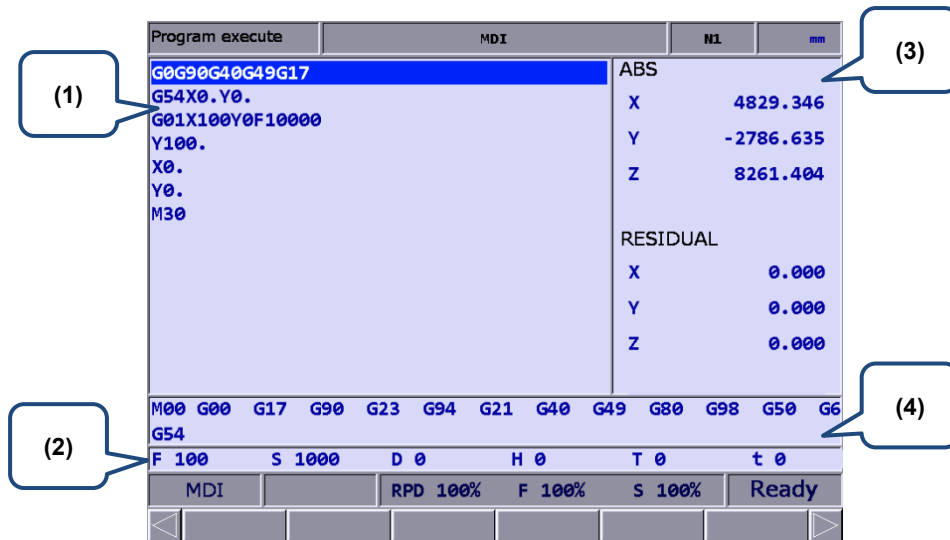

Figure 5.8.5

- (1) MDI program
- (2) Information of cutting feedrate, spindle speed, and compensation number
- (3) Coordinate information: absolute / residual coordinates
- (4) Status of currently executed commands

■ Offset (OFS) group

Coordinate information:

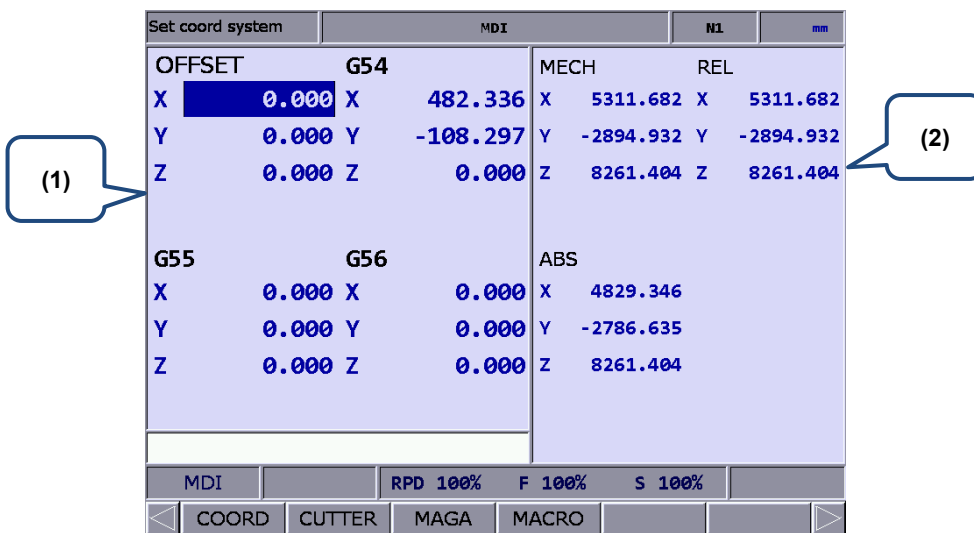

Figure 5.8.6

- (1) Workpiece coordinate setting: offset coordinates, G54 - G59 coordinate system
- (2) Coordinate information display: machine / relative / absolute coordinates



5

Tool information:

Cutter register		MDI			N1	mm
Num	Length	Radius	Len wear	Rad wear	LIFE	
1	-283.400	0.000	0.000	0.000	0	
2	0.000	0.000	0.000	0.000	0	
3	-141.900	0.000	0.000	0.000	0	
4	0.000	0.000	0.000	0.000	0	
5	0.000	0.000	0.000	0.000	0	
6	0.000	0.000	0.000	0.000	0	
7	0.000	0.000	0.000	0.000	0	
8	0.000	0.000	0.000	0.000	0	
9	0.000	0.000	0.000	0.000	0	
10	0.000	0.000	0.000	0.000	0	
11	0.000	0.000	0.000	0.000	0	
12	0.000	0.000	0.000	0.000	0	
13	0.000	0.000	0.000	0.000	0	
14	0.000	0.000	0.000	0.000	0	
15	0.000	0.000	0.000	0.000	0	

MDI		RPD 100%	F 100%	S 100%	Ready
ABS	INC	SET H	CLEAR		

Figure 5.8.7

- (1) Compensation number (H / D)
- (2) Input field for compensation data
- (3) Compensation information: tool length, tool radius, length compensation, and radius compensation
- (4) Auxiliary display: actual position of the current Z axis machine coordinate

■ Diagnosis (DGN) Group

Servo Tuning:

Servo Tuning				0036ZMC13XZ_1.NC		N1	SFT
Ch	0	Current	0 %	JL/Jm	0.0	MECH	5311.682
Axis	X					POS 1	-----
						POS 2	-----
No.	Parameter Name	Calculate	In Drive			Rigidity	1
P1-37	Load Inertia Ratio	0.0	0.0			BW	100 Hz
P2-00	Position Loop P gain	125	125			JL/Jm	4.0
P2-02	Position Feedforward	0	0			Acc. Time	200 ms
P2-04	Speed Loop P gain	502	502			S Time	20 ms
P2-06	Speed Loop I gain	80	80			Speed	3000 mm
P2-25	OSC. Reject filter	20	20			Interval	500 ms
P2-26	External Noise Reject	0	0				
P2-49	Speed D Filter and J Suppression	[0F]: 800	[0F]: 800				
P2-47	Auto Resonance Suppression Sel	0	0				
P2-23	Notch filter Freq(1)	262	262				
P2-24	Notch filter Gain(1)	5	5				
P2-43	Notch filter Freq(2)	562	562				
P2-44	Notch filter Gain(2)	22	22				
P2-45	Notch filter Freq(3)	1125	1125				
P2-46	Notch filter Gain(3)	3	3				

Figure 5.8.8

- (1) Servo parameter: numbers and names of servo parameters
- (2) Results after gain tuning: displays the calculation results of auto tuning
- (3) System settings: displays the current servo settings
- (4) Position setting: Position 1 / Position 2
- (5) Tuning conditions

MLC Operation / Edit:

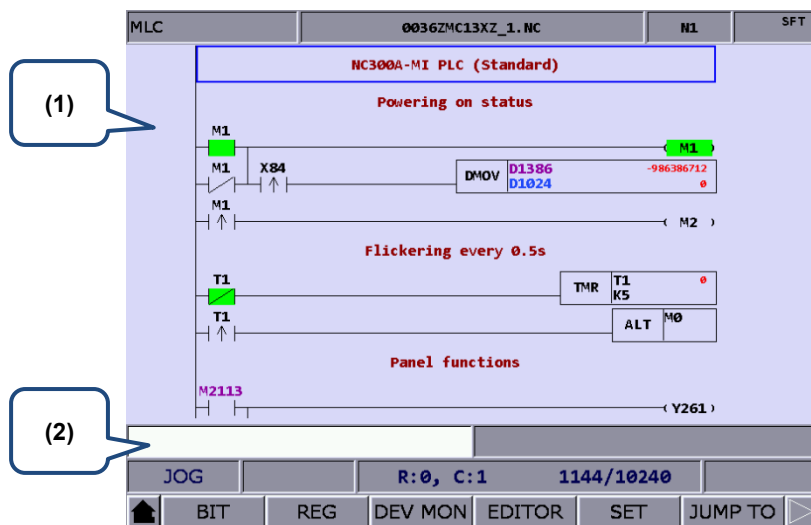

Figure 5.8.9

- (1) MLC program
- (2) Input field for command name

■ Alarm (ALM) Group

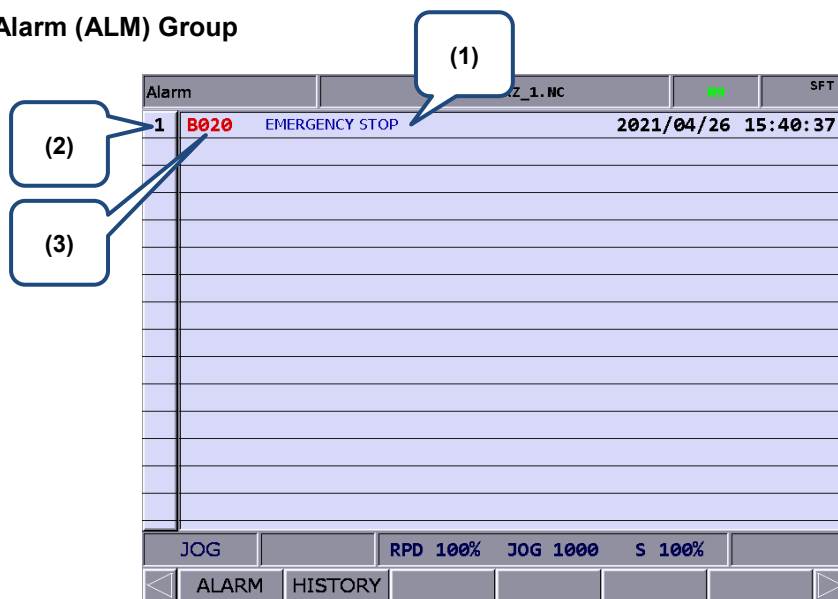

Figure 5.8.10

- (1) Alarm message
- (2) Sequence of alarm occurrence
- (3) Alarm code

■ Graph (GRA) Group

5

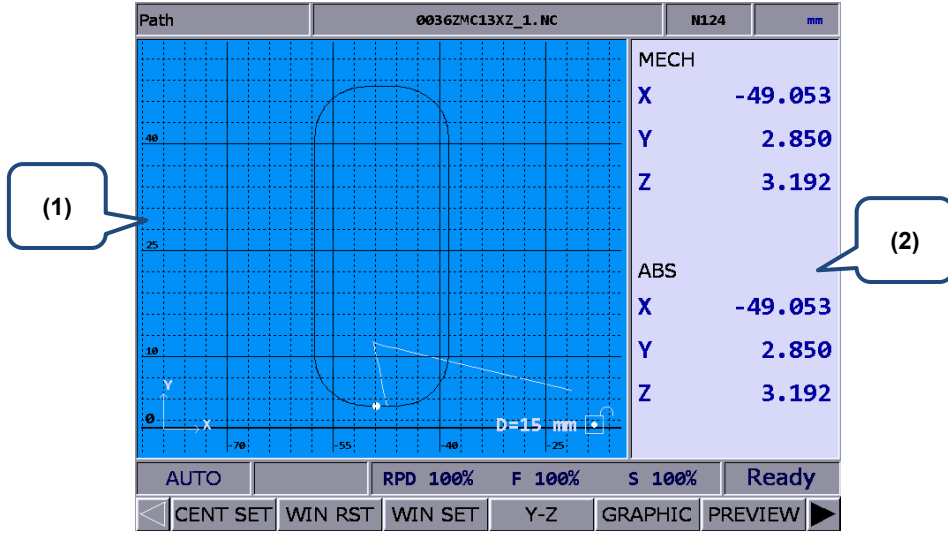

Figure 5.8.11

- (1) Path diagram: displays the program path
- (2) Coordinate information: machine / absolute coordinates

# Position (POS) Group

---

# 6

POS group displays the axes positions, which are represented in absolute, relative, and machine coordinates.



6.1	Absolute coordinates .....	6-3
6.2	Relative coordinates .....	6-3
6.3	Machine coordinates.....	6-3

# 6

POS group displays the axes positions, which are represented in absolute, relative, and machine coordinates. It can display the coordinates of up to three linear axes and one rotation axis according to the axis setting.

Note: bold function names in a box (such as **POS**) mean the keys on machine operation panel A; bold function names (such as **CLR ALL**) mean the function keys of F1 - F6.

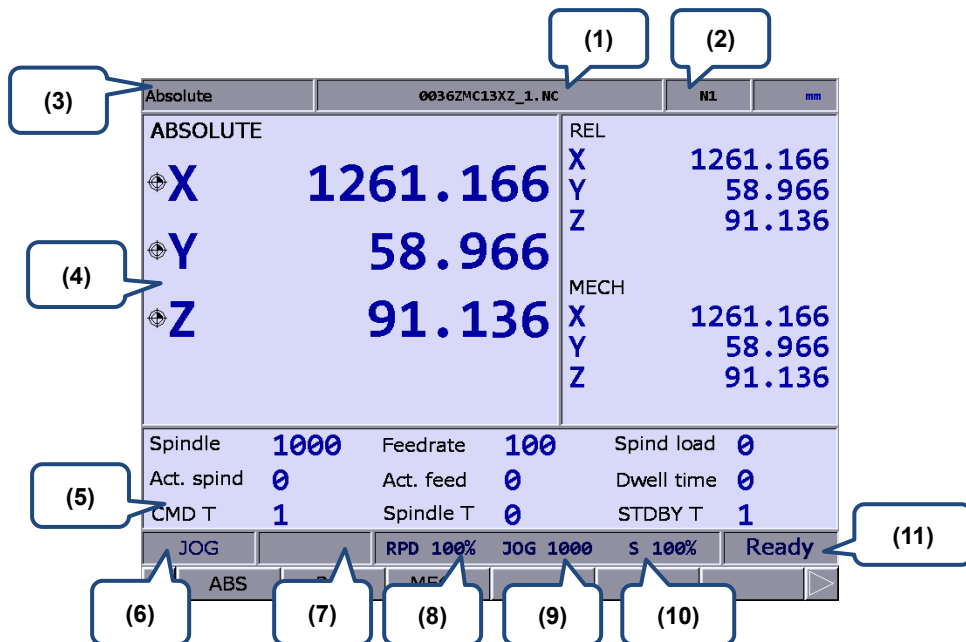

- (1) Name of current program
- (2) Currently executed program line
- (3) Current group function
- (4) Current coordinates
- (5) Machining information:
  - Spindle speed: command value
  - Cutting feedrate: command value
  - Spindle load rate: %
  - Actual speed: rpm
  - Actual feedrate: mm/min
  - Dwell time: G-code dwell time
  - Command tool number: tool number specified in G-code
  - Spindle tool number: number of the tool on the spindle
  - Standby tool number: system standby tool number
- (6) Current system mode
- (7) Alarm display
- (8) Rapid traverse override
- (9) Feedrate override
- (10) Spindle override
- (11) System status

## 6.1 Absolute coordinates

Absolute coordinates refer to the program origin of G-code, which you can use to check whether the movement specified in a program block is identical to the actual movement. The operation steps are as follows.

- (1) Press **POS** to display the POS group screen and the available functions include absolute coordinates (ABS), relative coordinates (REL), and machine coordinates (MECH).
- (2) Press **ABS** to enter the absolute coordinate screen.

## 6.2 Relative coordinates

Relative coordinates indicate the moving distance from the origin. The operation steps are as follows.

- (1) Press **POS** to display the POS group screen and the available functions include absolute coordinates (ABS), relative coordinates (REL), and machine coordinates (MECH).
- (2) Press **REL** to enter the relative coordinate screen.
- (3) The functions available in the 2<sup>nd</sup> layer function bar include:
  - CLR ALL**: clears the relative coordinate values of all axes.
  - CLR X**: clears the relative coordinate value of X axis.
  - CLR Y**: clears the relative coordinate value of Y axis.
  - CLR Z**: clears the relative coordinate value of Z axis.
  - CLR A**: clears the relative coordinate value of A axis.
  - CLR B**: clears the relative coordinate value of B axis.
  - CLR C** (next page): clears the relative coordinate value of C axis.

Note: the clear functions for the axes X, Y, Z, A, B, and C are available only when you connect the axes.

## 6.3 Machine coordinates

Machine coordinates are defined according to the mechanism. The coordinate data is neither removable nor changeable due to the selected workpiece coordinate system. The operation steps are as follows.

- (1) Press **POS** to display the POS group screen and the available functions include absolute coordinates (ABS), relative coordinates (REL), and machine coordinates (MECH).
- (2) Press **MECH** to enter the machine coordinate screen.

(This page is intentionally left blank.)

# 6

# Program (PRG) group

# 7

The PRG group provides functions of file management and program editing for G-code and macro files. In addition, some functions are dedicated to particular system modes.

---

7.1	Ethernet setting .....	7-3
7.2	Create a new file (NEW F) .....	7-8
7.3	Copy files (COPY F) .....	7-9
7.4	Paste files (PASTE) .....	7-9
7.5	Delete files and directories (DEL) .....	7-9
7.6	Select / cancel selection of multiple files (ALL SEL TOGL / CANCEL) .....	7-10
7.7	Rename files (RENAME) .....	7-12
7.8	Create directories (FOLDER) .....	7-13
7.9	Search for files (FIND F) .....	7-14
7.10	File merging (MERGE) .....	7-14
7.11	Sequencing (SORT) .....	7-15
7.12	Convert DXF files (Transform) .....	7-16
7.13	Macro files (MACRO) .....	7-17
7.14	Save macros in the bottom layer (INT MRO) .....	7-17
7.15	File editing (File edit) .....	7-17
7.15.1	Line search (LABEL) .....	7-19
7.15.2	String search (STRING) .....	7-19
7.15.3	Edit a section of program (B START / B END) .....	7-21
7.15.4	Delete lines and sections (DEL) .....	7-22
7.15.5	Copy lines and sections and paste (COPY and PASTE) .....	7-22
7.15.6	Undo (UNDO) .....	7-22
7.16	Program function in other modes .....	7-23



7

You can manage and edit G-code and macro files with PRG group functions. File manage includes three layers: (1) CF (CF card), INTER (internal memory), USB (USB disk), and NETWORK; (2) folders and G-code files; (3) G-code files.

Some dedicated functions are available in particular system modes. For example, you can use the function of break line search in AUTO mode or you can enter and execute a program in MDI mode.

Note: bold function names in a box (such as **POS**) mean the keys on machine operation panel A; bold function names (such as **CLR ALL**) mean the function keys of F1 - F6.

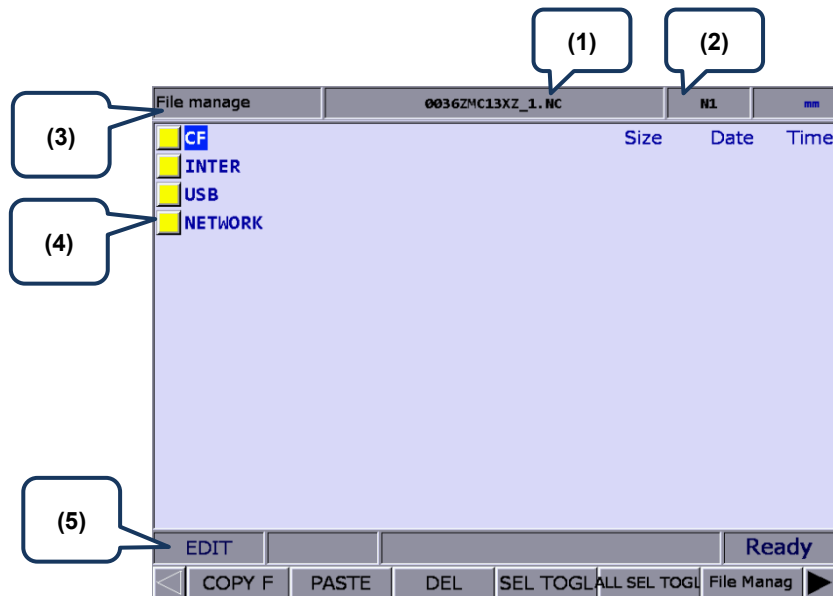

- (1) Name of current program
- (2) Currently executed program line
- (3) Current group function
- (4) Disk options
- (5) Current system mode

Set the system to EDIT mode and press **PRG** on machine operation panel A to display the PRG screen. In the File manage screen, you can press **↑** and **↓** or **PAGE UP** and **PAGE DN** to move the cursor, press **ENTER** to enter the second or third layer, and then select a G-code file.

After selecting the G-code file, press **ENTER** to open the file and enter the edit screen. Press **↑** and **↓** (scroll the screen up or down by 1 line), and **PAGE UP** and **PAGE DN** (scroll the screen up or down by 20 lines) to display the file content.

Note: the suggested specifications for the USB disk is as follows.

USB disk specification	
Disk format	FAT32
Disk capacity	As required

## 7.1 Ethernet setting

You can use Ethernet to connect the system to the PC to enable remote communication. You can use the CNCNetwork software to manage the online files of multiple NC controllers with one PC, enabling data sharing and file management with the PC, and transmission-along-with-machining (DNC).

Set the communication protocol between the NC system and PC before using the network connection function. Refer to section 12.7.1 for the setting method. The following gives simple instructions.

Set the protocol of the NC system by going to **PAR > ETH**.

Ethernet		0036ZMC13XZ_1.NC		N1	SFT
No.	Parameter Name		Value		
10030	Host name		TTT		
10031	IP address	P	192.168. 1. 7		
10032	Subnet mask	P	255.255.255. 0		
10033	Default gateway	P	192.168. 1. 1		
10034	Network function	P	3		
	• Network function switch (0: off; 1: on)		1		
	• Remote PC IP restriction (0: specified; 1: domain)		1		
10035	DHCP switch (0: off; 1: on)	P	0		
10036	Remote PC IP address 1		192.168. 1. 5		
10037	Remote PC IP address 2		192.168. 1. 9		
10038	Remote PC IP address 3		0. 0. 0. 0		
10039	Remote PC IP address 4		0. 0. 0. 0		
10040	Remote PC IP address 5		0. 0. 0. 0		
10041	Shared remote directory IP address		2		
10055	FTP setting	P	0		
			Length: 1 ~ 8		
EDIT		Ch 0	1/2	Ready	
DEFAULT					

Figure 7.1.1

Network setting parameter		
Number	Name	Setting range or format
10030	Host name	Character length: 1 - 8 Actual setting: 1 - 8 characters
10031	IP address	Character length: xxx.xxx.xxx.xxx Actual setting: 192.168.0.2
10032	Subnet mask	Character length: xxx.xxx.xxx.xxx Actual setting: 255.255.255.0
10033	Default gateway	Character length: xxx.xxx.xxx.xxx Actual setting: 0.0.0.0
10034	Network function switch	Character length: 0 - 1 Actual setting: 1
10035	DHCP switch	Character length: 0 - 1 Actual setting: 0
10036	Remote PC IP address 1	Character length: xxx.xxx.xxx.xxx Actual setting: 192.168.0.1
10037	Remote PC IP address 2	Character length: xxx.xxx.xxx.xxx Actual setting: 0.0.0.0
10038	Remote PC IP address 3	Character length: xxx.xxx.xxx.xxx Actual setting: 0.0.0.0
10039	Remote PC IP address 4	Character length: xxx.xxx.xxx.xxx Actual setting: 0.0.0.0

7

Network setting parameter		
Number	Name	Setting range or format
10040	Remote PC IP address 5	Character length: xxx.xxx.xxx.xxx Actual setting: 0.0.0.0
10041	Shared remote directory IP address	Character length: 0 - 5 Actual setting: 0

Set the protocol of PC by setting Internet Protocol (TCP/IP) Properties on the PC operating system (as shown in Figure 7.1.2) or going to **CNCNetwork > Options**.

Network setting on PC:

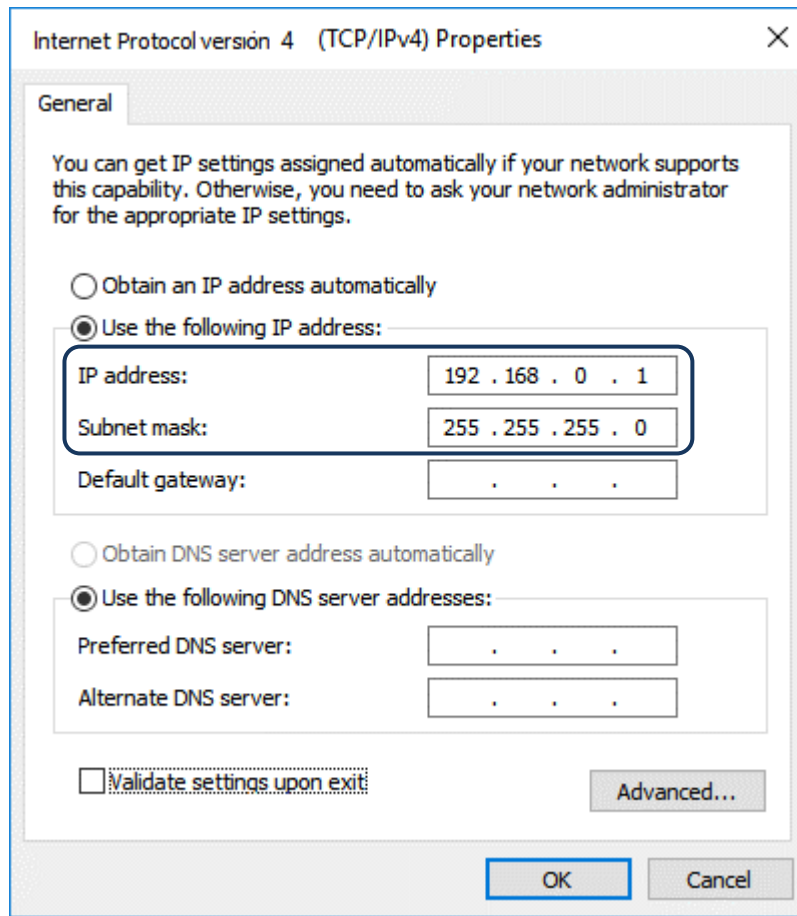

Figure 7.1.2

Steps:

- (1) Select the check box for **Use the following IP address** and enter the following in sequence:  
 IP address: **192 . 168 . 0 . 1**  
 Subnet mask: **255 . 255 . 255 . 0**
- (2) Click **OK** to finish the setting.

## Network settings with CNCNetwork:

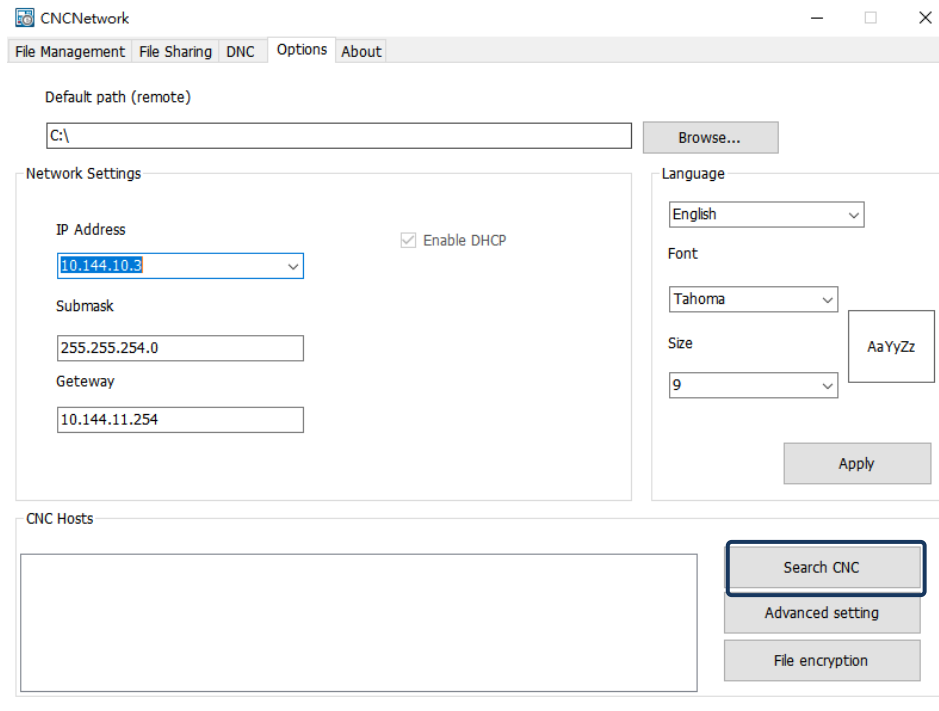

Figure 7.1.3

## Steps:

- (1) Execute CNCNetwork software and go to the **Options** tab.
- (2) Click **Search CNC** to connect to the CNC with the above settings.

7

7

**DNC operation:**

Execute CNCNetwork, open the file to be shared in the File Sharing screen, and then you can execute the G-code file while it is being processed (DNC operation) using Ethernet.

No additional disk space is required for file storage as only the path of the shared files is recorded. The connection steps are as follows.

- (1) Use Ethernet communication to set the Internet connection between PC and NC.
- (2) Execute CNCNetwork.
- (3) Click the **DNC** tab.

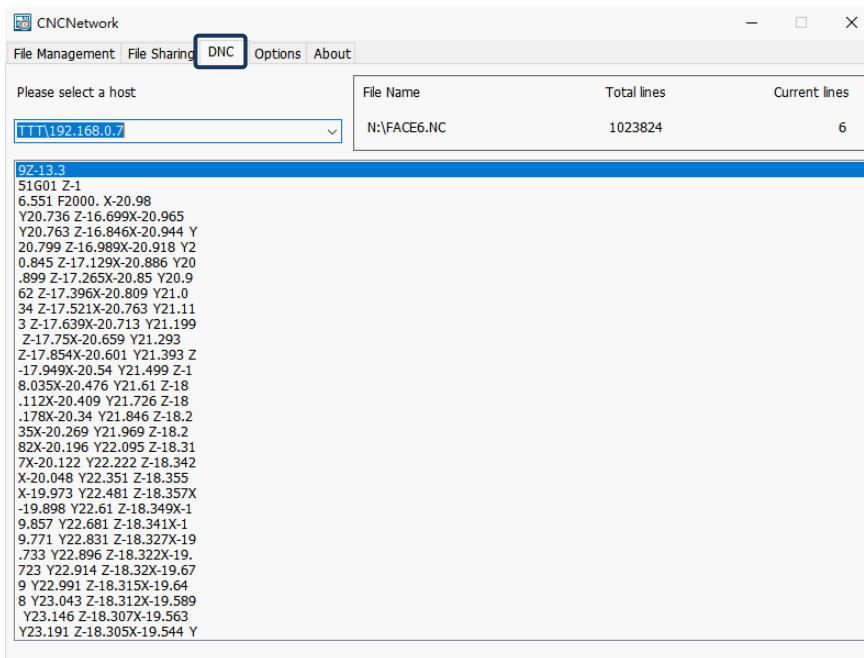

Figure 7.1.4

- (4) Set the system to EDIT mode and go to **File manage > NETWORK**.

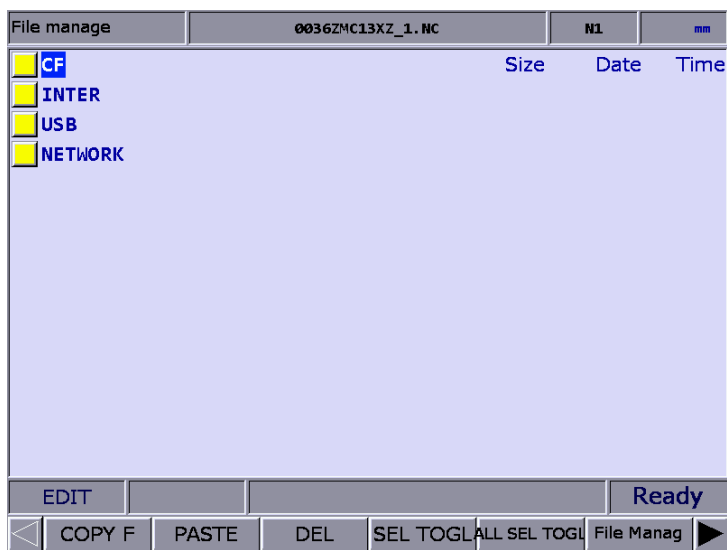

Figure 7.1.5

- (5) The screen displays the shared files. Select and open the G-code file that has been set to be shared.

- (6) Set the system to AUTO mode, press **CYCLE START**, and the system executes the G-code file by DNC operation. The execution method is the same as that for general files.
- (7) During DNC operation, file information is displayed in the DNC screen of CNCNetwork. The information includes name of the connecting system, name of the file executed by DNC, total number of lines, number of line being executed, and file content (the content is scrolled down along with the execution progress, as shown in Figure 7.1.6).

7

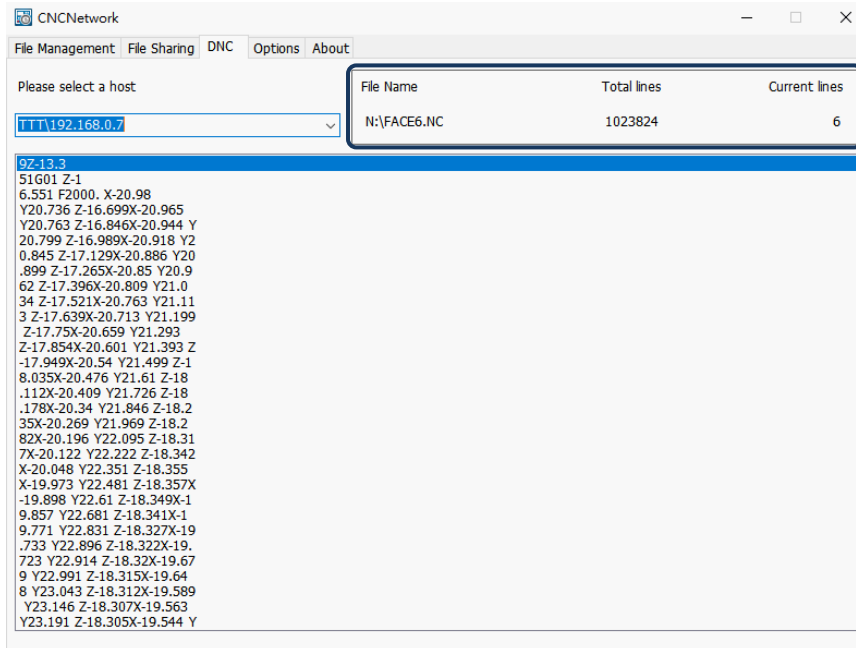

Figure 7.1.6

## 7.2 Create a new file (NEW F)

In EDIT mode, you can use this function to create a new G-code file from the controller interface. The operation steps are as follows.

- (1) Set the system to EDIT mode.
- (2) Press **PRG** to switch to the PRG screen.
- (3) In the File manage screen, press **↑** and **↓** or **PAGE UP** and **PAGE DN** to move the cursor to the destination of the disk for file creation (for example, the 2<sup>nd</sup> or 3<sup>rd</sup> layer of CF or USB directory).
- (4) Press **▶** to display the function bar on the next page.
- (5) Press **NEW F** and a dialog box appears for you to enter the file name.
- (6) Enter alphanumeric characters (no symbols) in the dialog box, press **ENTER**, and a new file is created.

File format specifications	
Format of machining file name (G-code)	No restrictions on the format of main program names (names of each file should be unique in the same directory) O + 0001 to 8999 (for subprogram call)
Format of macro file name (O macro)	O + 9000 - 9999
Remarks in file name	Suffix '-' and alphanumeric characters in sequence to the file name
Valid format of file extension	.NC .ANC .CNC .PIM .TAP .PTP .UOO .DEMO
Format of M macro file name	M + 10000 - 29999
Format of G macro file name	G + 30000 - 49999
Maximum allowable character length of file name	31
Storage location	2 <sup>nd</sup> or 3 <sup>rd</sup> management layer
Invalid symbols in file name	* / \   < > ? "

Note:

1. Names of each file should be unique in the same directory. For example, O0001 and O1 are regarded as the same.
2. The File manage screen only displays general machining files. Macro files can be displayed by setting the parameter Pr50 Macro file display.
3. Multiple dots can be used in the file name of a G-code file whereas the last one should come with a valid format of file extension, such as "1.1.1.1.NC".

### 7.3 Copy files (COPY F)

You can use this function to copy the existing files from all disk drives.

The operation steps are as follows.

- (1) Set the system to EDIT mode.
- (2) Press **PRG** to switch to the PRG screen.
- (3) In the File manage screen, press **↑** and **↓** or **PAGE UP** and **PAGE DN** to move the cursor to the destination of the disk for file copying (for example, the 2<sup>nd</sup> or 3<sup>rd</sup> layer of CF or USB directory).
- (4) Move the cursor to the file to be copied.
- (5) Press **COPY F** and then **PASTE** to validate the execution.

### 7.4 Paste files (PASTE)

As described in Section 7.3, you should use this function together with the copy function to complete file copying. It is one of the functions of File manage in PRG group. The operation steps follow the descriptions in Section 7.3.

- (1) Press **↑** and **↓** or **PAGE UP** and **PAGE DN** to move the cursor to the location of the disk, directory, or layer for pasting the file.
- (2) Enter the directory, press **PASTE**, and a dialog box appears for you to enter the file name. Enter a new file name or use the original one, and press **ENTER** to complete the execution of file copying and pasting.

Note:

1. The specification of file naming for this function is the same as that of the file creation function. That is, file names of each file should be unique.
2. If you do not execute **COPY F** before using the **PASTE** function, an error dialog box appears to remind you to copy a file first, and thus the paste execution is invalid.
3. Follow the same operation steps to copy the files from the USB disk to the CF card.

### 7.5 Delete files and directories (DEL)

You can use this function to delete the G-code files and directories in the second layer of **File manage**.

The operation steps are as follows.

- (1) Set the system to EDIT mode.
- (2) Press **PRG** to switch to the PRG screen.
- (3) In the File manage screen, press **↑** and **↓** or **PAGE UP** and **PAGE DN** to move the cursor, and press **ENTER** to enter the 2<sup>nd</sup> or 3<sup>rd</sup> layer of the disk.
- (4) Move the cursor to the directory or file to be deleted.



7

- (5) Press **DEL** and a dialog box appears for you to confirm the execution. Enter “Y” and press **ENTER** to delete the file or directory.

Note: the file or directory cannot be recovered once deleted.

### 7.6 Select / cancel selection of multiple files (ALL SEL TOGL / CANCEL)

In addition to copying or deleting a single file, you can use SET TOGL / CANCEL to select or cancel the selection of multiple files for copying, pasting, or deleting the files.

The operation steps for copying and pasting multiple files are as follows.

- (1) Set the system to EDIT mode.
- (2) Press **PRG** to switch to the PRG screen.
- (3) Enter the directory where you want to select the files.
- (4) In the File manage screen, press **↑** and **↓** or **PAGE UP** and **PAGE DN** to move the cursor to the file to be selected. To select a file, press **SEL TOGL** (as shown in Figure 7.6.1). To cancel the selection, press **CANCEL**. To select all files, press **ALL SEL TOGL**. To cancel the selection of all files, press **CANCEL**.

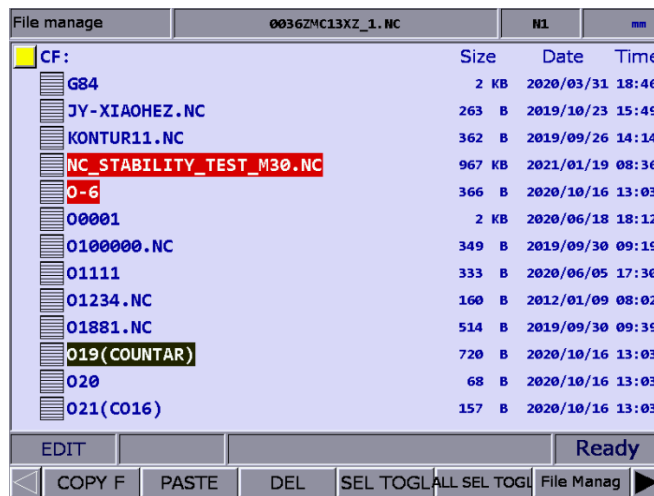

Figure 7.6.1

- (5) After completing the selection, press **COPY F**.
- (6) Go to another directory and press **PASTE** to paste the selected files, as shown in Figure 7.6.2.

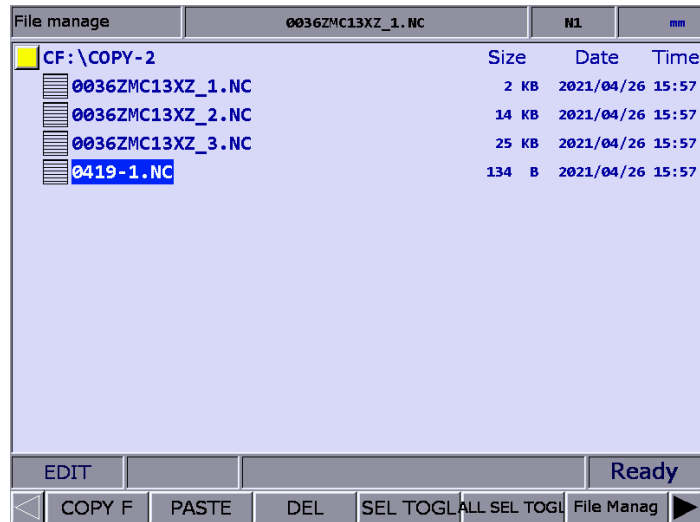

Figure 7.6.2

The operation steps for deleting multiple files are as follows.

- (1) Set the system to EDIT mode.
- (2) Press **PRG** to switch to the PRG screen.
- (3) Enter the directory where you desire to select the files.
- (4) In the File manage screen, press **↑** and **↓** or **PAGE UP** and **PAGE DN** to move the cursor to the file to be selected. To select a file, press **SEL TOGL**. To cancel the selection, press **CANCEL**.
- (5) After selecting multiple files, press **DEL**, and a dialog box appears for you to confirm the execution (as shown in Figure 7.6.3). Enter "Y" and press **ENTER** to delete.

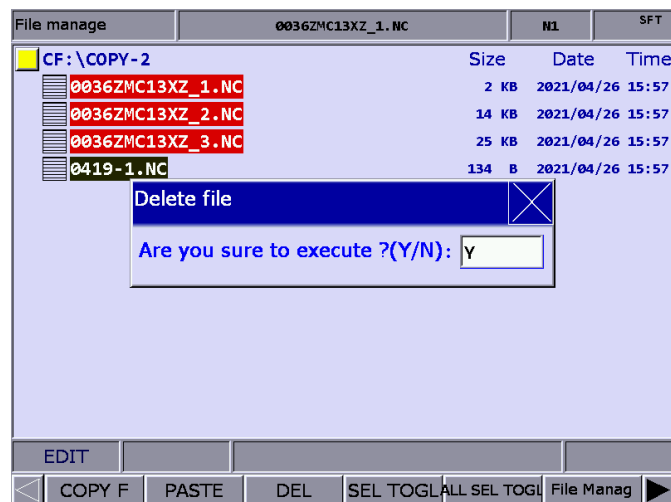



Figure 7.6.3

Note:

1. After copying multiple files, you should paste them to another directory. If you paste the files in the same directory, a dialog box appears to remind you to select another directory, and the execution is invalid.
2. When the names of the files to be pasted are identical to those of the original files, a dialog box appears for you to decide whether to overwrite the original files. Enter "Y" to replace the original files with the new ones; enter "N" or press **EXIT** to keep the original files.

## 7.7 Rename files (RENAME)

You can use this function to rename the file after creating the file. The operation steps are as follows.

- (1) Set the system to EDIT mode.
- (2) Press **PRG** to switch to the PRG screen.
- (3) In the File manage screen, press  and  or **PAGE UP** and **PAGE DN** to move the cursor to the destination of the disk (for example, the 2<sup>nd</sup> or 3<sup>rd</sup> layer of CF or USB directory).
- (4) Press **▶** to display the function bar on the next page.
- (5) Move the cursor to the file to be renamed, press **RENAME**, and a dialog box appears for you to enter the file name.
- (6) Enter a name that is not identical to the file names in the directory, and press **ENTER** to complete renaming the file.

Note:

1. You can only create G-code files in the 2<sup>nd</sup> and 3<sup>rd</sup> layers of File manage but not in the 1<sup>st</sup> layer.
2. The format specification of file name for file renaming is the same as that of file creation. If you enter a name that is already used for another file in the directory when renaming, an error dialog box appears, and the execution is invalid.

### 7.8 Create directories (FOLDER)

This function is for creating a directory for G-code files in the 2<sup>nd</sup> layer of File manage, which is only available in the 2<sup>nd</sup> layer of File manage. Accordingly, the 2<sup>nd</sup> layer of File manage can contain both directories and G-code files. The operation steps are as follows.

- (1) Set the system to EDIT mode.
- (2) Press **PRG** to switch to the PRG screen.
- (3) Press **▶** to display the function bar on the next page.
- (4) In the 2<sup>nd</sup> layer of File manage, press **FOLDER**, and a dialog box appears for you to enter the directory name.

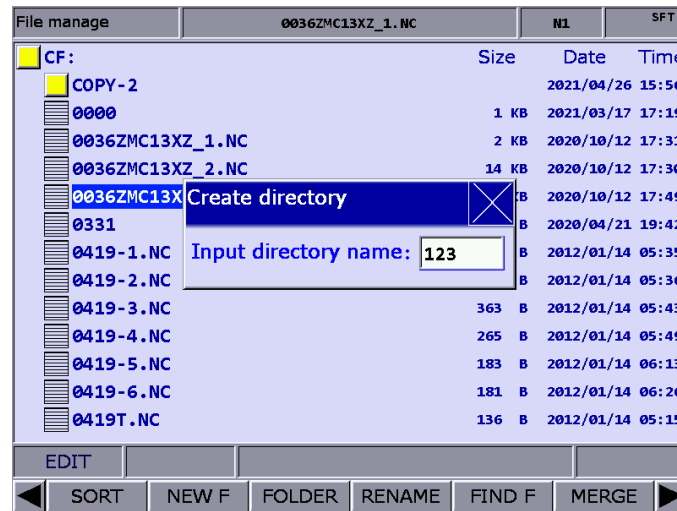

Figure 7.8.1

- (5) After entering the directory name, press **ENTER** to complete creating the directory.

By following the steps above, you can create a new directory in the 2<sup>nd</sup> layer of File manage, and create and edit G-code files in this directory (the 3<sup>rd</sup> layer).

Directory format specifications	
Format of directory name	Not limited to alphanumeric characters
Maximum number of characters of directory name	31
Storage location	2 <sup>nd</sup> management layer

## 7.9 Search for files (FIND F)

You can use this function to quickly search for and open the target file when there are a number of G-code files in the directory. If you know the file name, this function enables you to quickly search for and open the file. The operation steps are as follows.

- (1) Set the system to EDIT mode.
- (2) Press **PRG** to switch to the PRG screen.
- (3) In the File manage screen, press **↑** and **↓** or **PAGE UP** and **PAGE DN** to move the cursor, and press **ENTER** to enter the 2<sup>nd</sup> or 3<sup>rd</sup> layer of the disk.
- (4) Press **▶** to display the function bar on the next page.
- (5) Press **FIND F** and a dialog box appears for you to enter the file name to be searched. After entering the file name, press **ENTER** to search for and open the file.

Note:

1. You can only search for files in the same directory with this function.
2. Enter the complete file name to accurately search for and open the file.



## 7.10 File merging (MERGE)

You can use this function with the file copying function to merge the program content of two different G-code files. The operation steps are as follows:

- (1) Set the system to EDIT mode.
- (2) Press **PRG** to switch to the PRG screen.
- (3) In the File manage screen, press **↑** and **↓** or **PAGE UP** and **PAGE DN** to move the cursor, and press **ENTER** to enter the 2<sup>nd</sup> or 3<sup>rd</sup> layer of the disk.
- (4) Select the G-code file to be copied.
- (5) Press **COPY F** and the content is saved to the system's clipboard.
- (6) Move the cursor to the directory which contains the file to be merged.
- (7) Press **▶** to display the function bar on the next page.
- (8) Press **MERGE** and a dialog box appears for you to enter the name of the merged file. After entering the name, press **ENTER** to open the file.
- (9) Move the cursor to the line where you want to paste the program content, and press **PASTE** to paste and merge the file programs.
- (10) To save the merged file, switch to different system modes, open another file, or press **RESET**.

## 7.11 Sequencing (SORT)

This function is for sequencing the directories or files in a directory by a specified order, facilitating the operation of file search or management.

- (1) Set the system to EDIT mode.
- (2) Press **PRG** to switch to the PRG screen.
- (3) In the File manage screen, press  and  or **PAGE UP** and **PAGE DN** to move the cursor, and press **ENTER** to enter the 2<sup>nd</sup> or 3<sup>rd</sup> layer of the disk.
- (4) Press **▶** to display the function bar on the next page.
- (5) Press **SORT** to display the function bar in the 2<sup>nd</sup> layer.
- (6) Press **NAME**, and the directories and files are displayed by the sequence of number > English letters (from top to bottom). Press **NAME** again, and they are displayed by the sequence of English letters > number (from top to bottom).
- (7) Press **SIZE** to display the directories and files by the file size from small to large (from top to bottom). Press **SIZE** again to display them by the file size from large to small (from top to bottom).
- (8) Press **DATE** to display the directories and files by the date from most recent to earlier (from top to bottom). Press **DATE** again to display them by the date from earlier to most recent (from top to bottom).

## 7.12 Convert DXF files (Transform)

You can find this function from the function bar in the File manage screen. After selecting the DXF file, enter relevant parameter settings to convert them into an executable G-code file.

- (1) Set the system to EDIT mode.
- (2) Press **PRG** to switch to the PRG screen.
- (3) Press **▶** twice to display the function bar on the third page.
- (4) Press **DXF** to display the DXF file manage screen.
- (5) In the File manage screen, press **↑** and **↓** or **PAGE UP** and **PAGE DN** to move the cursor, and press **ENTER** to select the DXF file to be converted.
- (6) After selecting the DXF file, you are redirected to the screen for setting the relevant parameters, as shown in the following figure.

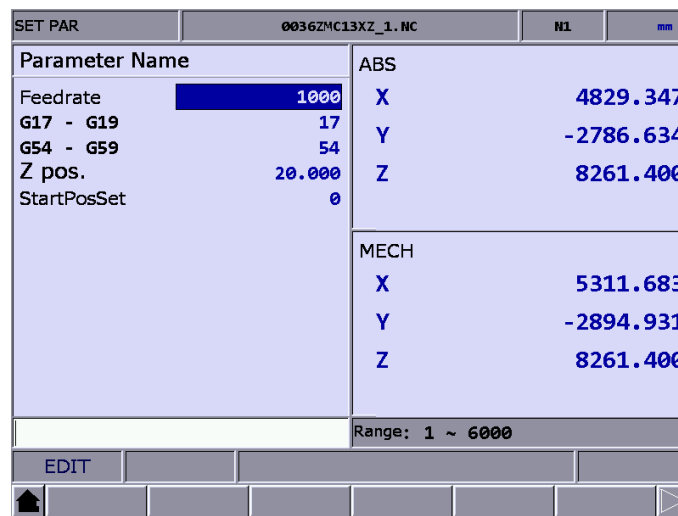

Figure 7.12.1

- (7) After finishing setting the parameters, press **Transform**, a dialog box appears for you to enter the new file name.
- (8) After entering the file name, press **ENTER** to convert the DXF file into a G-code file, and the G-code file is stored in the CF directory.
- (9) Then, you can execute the G-code file in AUTO mode.

### 7.13 Macro files (MACRO)

In response to the application requirements, this is a dedicated function of managing the macro files for the equipment. Upon accessing the security authorization, you can use all the editing functions described in Section 7.14. Otherwise, you can only browse the existing macro files rather than open and edit them. Contact the local distributor for authorization settings.

### 7.14 Save macros in the bottom layer (INT MRO)

In response to the application requirements, this function allows you to copy the macro programs in the internal memory or CF card to the bottom layer of the system, speeding up the file access.

Note:

- (1) Pr50 Display O macro file must be set to 0.
- (2) The number of macro program files must be no more than 50.
- (3) Example: Z-axis tool calibration with tool setter.

### 7.15 File editing (File edit)

You can use this function to modify or delete the content of the G-code files. After you open the file in the File manage screen, the system switches to the File edit screen. Move the cursor to any position in the program and use the alphabetic, numeric, and editing keys on machine operation panel A to edit the program. To save the file after editing the program, switch to different system modes, press **RESET**, or open another file. The operation steps for entering the File edit screen are as follows.

- (1) Set the system to EDIT mode.
- (2) Press **PRG** to switch to the PRG screen.
- (3) Press **↑** and **↓** or **PAGE UP** and **PAGE DN** to move the cursor, and press **ENTER** to enter the 2<sup>nd</sup> or 3<sup>rd</sup> layer of the disk.
- (4) Select the G-code file to be edited, and press **ENTER** to open the file and enter the edit screen.
- (5) Press **↑**, **↓**, **←**, and **→** to move the cursor to any position in the program.
- (6) Edit the content by pressing the alphabetic, numeric, and editing keys on machine operation panel A.



- (7) To save the file after editing, switch to different system modes, open another file, or press **RESET**.

7

Specifications for editing	
Maximum number of characters of a single line	255
Supported mode	EDIT mode
Allowable file size	Below 3 MB

Note:

1. When using the File manage or File edit function, you have to set the system to EDIT mode to display the corresponding function bar. Otherwise, the PRG screen is only for viewing the currently opened program file and displays the coordinate information.
2. You can insert “( )” (parentheses) at the end of each program block in the G-code file for making notes. Do not insert parentheses in the beginning of the program block, or the block may be taken as a note and be skipped.

### 7.15.1 Line search (LABEL)

This function is for searching the specific line of program in the G-code file. The operation steps are as follows.

- (1) Set the system to EDIT mode.
- (2) Press **PRG** to switch to the PRG screen.
- (3) Press **↑** and **↓** or **PAGE UP** and **PAGE DN** to move the cursor, and press **ENTER** to enter the 2<sup>nd</sup> or 3<sup>rd</sup> layer of the disk.
- (4) Select the G-code file to be edited, and press **ENTER** to open the file and enter the edit screen.
- (5) Press **▶** to display the function bar on the next page.
- (6) Press **LABEL** and a dialog box appears for you to enter the line number (by pressing the numeric keys 0 - 9).
- (7) After entering the line number, press **ENTER**, and the cursor jumps to the specified line, completing the action.

Requirements for line search	
Maximum number of characters of searching string	62
Format of searching string	Specify the program line number

### 7.15.2 String search (STRING)

The line search function is only for searching the specific line while you can use this function to search for specific strings. The accuracy of the searching result depends on how precise the input string is. The string search function contains the function of string replacing. You can determine whether to replace a string when searching for a string, which enables you to directly replace the string on the panel screen. The operation steps are as follows.

- (1) Set the system to EDIT mode.
- (2) Press **PRG** to switch to the PRG screen.
- (3) Press **↑** and **↓** or **PAGE UP** and **PAGE DN** to move the cursor, and press **ENTER** to enter the 2<sup>nd</sup> or 3<sup>rd</sup> layer of the disk.
- (4) Select the G-code file to be edited, and press **ENTER** to open the file and enter the edit screen.
- (5) Press **▶** to display the function bar on the next page.

- (6) Press **STRING** and a dialog box appears for you to enter the string to be searched, as shown in the following figure.

7

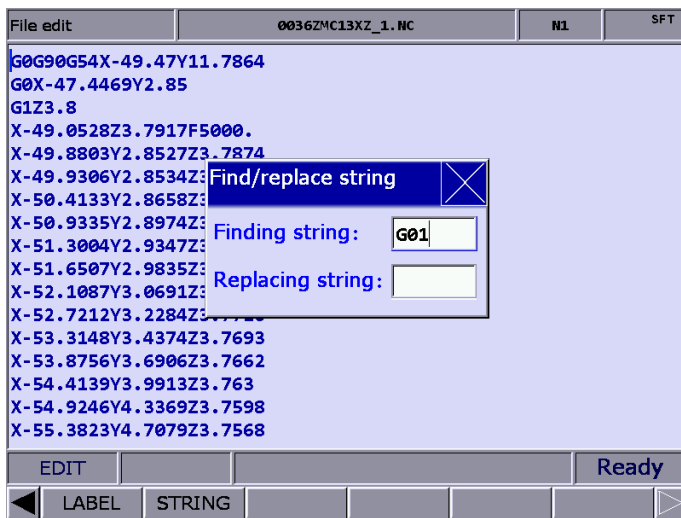

Figure 7.15.2.1

- (7) After entering the string to be searched and the string to be replaced, press **ENTER** to search the string.
- (8) After that, the searched string is highlighted. At the same time, “NEXT”, “PREV”, “REPLACE”, and “Replace all” are displayed on the function bar.
- (9) Press **NEXT** to search for the next match or press **PREV** to search for the previous match.
- (10) Press **REPLACE** when you want to replace one single string. You can press **Replace all** to batch replace the matches with the new string.
- (11) Press **◀** to exit the string search function and go back to the function bar of File edit.
- (12) After replacing the string, ensure to save the results (by switching to different system modes, opening another file, or pressing **RESET**).

Requirements for string replacing	
Modes that allow the string replacement function	EDIT mode
Allowable file size for editing and replacing	Below 3 MB

### 7.15.3 Edit a section of program (B START / B END)

To edit a section of a program, you can use the B START / B END functions to specify the start and end of the content to be edited. Then, you can delete, copy, and paste the selected program content as required, which simplifies the editing process. The operation steps are as follows.

- (1) Set the system to EDIT mode.
- (2) Press **PRG** to switch to the PRG screen.
- (3) Press **↑** and **↓** or **PAGE UP** and **PAGE DN** to move the cursor, and press **ENTER** to enter the 2<sup>nd</sup> or 3<sup>rd</sup> layer of the disk.
- (4) Select the G-code file to be edited, and press **ENTER** to open the file and enter the edit screen.
- (5) Press **↑**, **↓**, **←**, and **→** to move the cursor to the start of the section to be edited and press **B START**.
- (6) Move the cursor to the end of the section to be edited and press **B END**. See the following figure for the selected section.

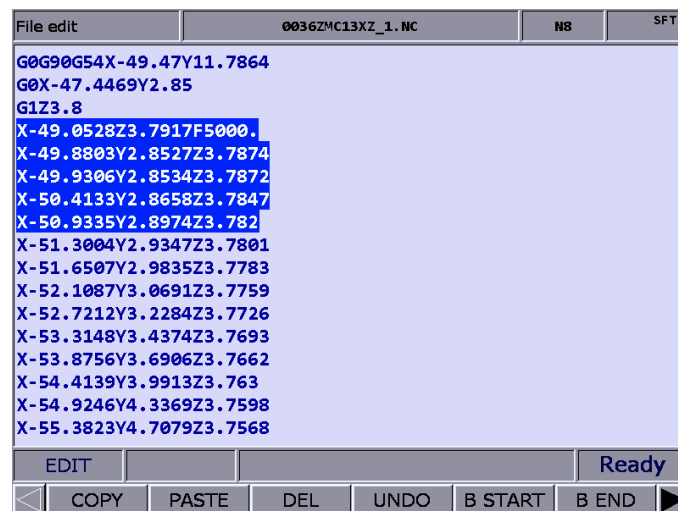

Figure 7.15.3.1

- (7) Follow Steps (5) - (6) then press **DEL**, and you can delete the selected content.
- (8) Follow Steps (5) - (6) then press **COPY** to copy the selected content. Move the cursor to where you wish to paste the copied content and press **PASTE** to insert the content.

## 7

### 7.15.4 Delete lines and sections (DEL)

You can use this function to delete a single line of program where the cursor is located. And you can use this function with B START and B END to delete a whole section of the program. The operation steps are as follows.

- (1) Set the system to EDIT mode.
- (2) Press **PRG** to switch to the PRG screen.
- (3) Press **↑** and **↓** or **PAGE UP** and **PAGE DN** to move the cursor, and press **ENTER** to enter the 2<sup>nd</sup> or 3<sup>rd</sup> layer of the disk.
- (4) Select the G-code file to be edited, and press **ENTER** to open the file and enter the edit screen.
- (5) Move the cursor to the line to be deleted and press **DEL** to delete the line of program.
- (6) Follow Step (7) in Section 7.15.3 to delete a whole section of a program.

### 7.15.5 Copy lines and sections and paste (COPY and PASTE)

Move the cursor to the specified line and press **COPY**, which takes effect when used with the **PASTE** function. You can use this function to copy a single line or a section of the program content. The operation steps are as follows.

- (1) Set the system to EDIT mode.
- (2) Press **PRG** to switch to the PRG screen.
- (3) Press **↑** and **↓** or **PAGE UP** and **PAGE DN** to move the cursor, and press **ENTER** to enter the 2<sup>nd</sup> or 3<sup>rd</sup> layer of the disk.
- (4) Select the G-code file to be edited, and press **ENTER** to open the file and enter the edit screen.
- (5) Move the cursor to the line of program to be copied and press **COPY**.
- (6) Move the cursor to the position to paste the copied content, and press **PASTE** to paste the line of program to that position.
- (7) Follow Step (8) in Section 7.15.3 to copy a whole section of a program.

### 7.15.6 Undo (UNDO)

During program editing, use this function to undo the previous edit. You can repeatedly use this function for undoing up to 7 previous steps. The operation steps are as follows.

- (1) Set the system to EDIT mode.
- (2) Press **↑** and **↓** or **PAGE UP** and **PAGE DN** to move the cursor, and press **ENTER** to enter the 2<sup>nd</sup> or 3<sup>rd</sup> layer of the disk.
- (3) Select the G-code file to be edited, and press **ENTER** to open the file and enter the edit screen.
- (4) After editing the program, press **UNDO** to undo the previous edit one time.

## 7.16 Program function in other modes

### AUTO mode:

The PRG screen displays the content of the opened G-code file. In the screen, you can view the status information about the opened or executed file and the block being executed. The PRG screen in AUTO mode displays information about the program and the coordinates of motion trajectory during program execution. The operation steps are as follows.

- (1) In AUTO mode, press **PRG** to display the program execution screen. Refer to the following figure.

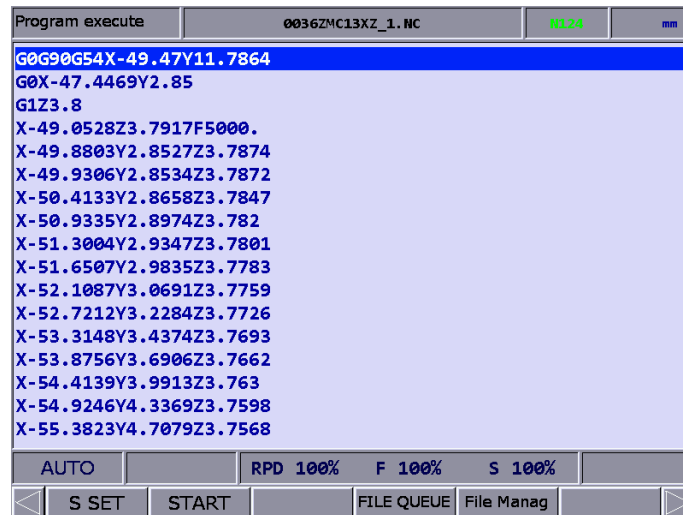

Figure 7.16.1

(2) Continued from Step (1), press **PRG** again, and the screen displays the information of both program content and coordinates, as shown in the following figure.

7

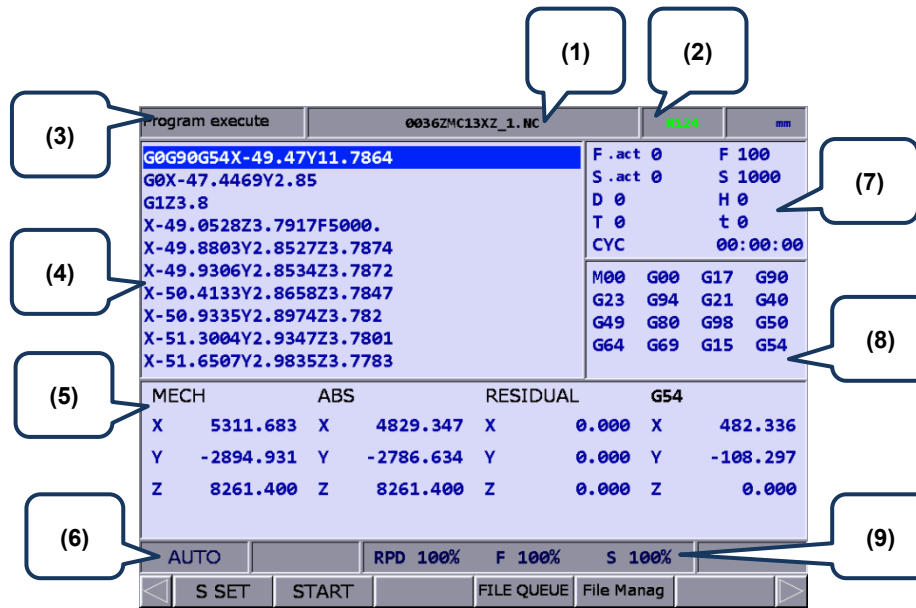

Figure 7.16.2

- (1) Name of current program
- (2) Currently executed program line
- (3) Current group function
- (4) Currently executed program content
- (5) Coordinate information during program execution
- (6) Current system mode
- (7) F.act: actual feedrate
- S.act: actual spindle speed
- D: tool radius compensation number
- H: tool length compensation number
- T: tool number
- F: feedrate
- S: spindle speed
- t: dwell time
- CYC: cycle time
- (8) Current command status
- (9) Current override settings

AUTO mode also includes the START (break line search) function. When the program execution is interrupted, the system records the line number where it is interrupted (break line). You can go to the PRG screen in AUTO mode to enable the break line search function.

When the system searches the break line, the cursor quickly moves to the line/label number you searched for and the system quickly computes and executes the program before the specified block to ensure the machining status is ready (including the spindle speed, feedrate, M code, and coordinates) when the execution resumes, as shown in the following figure.

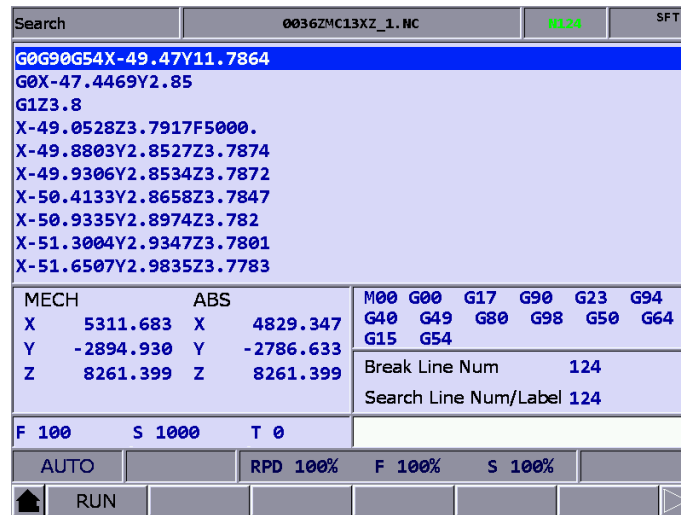

Figure 7.16.3

The operation steps are as follows.

- (1) In AUTO mode, press **PRG** to enter the program execution screen.
- (2) Press **START** to display the corresponding screen.
- (3) Refer to the information of break line number, enter the line or label number of the program to be searched, and then press **ENTER** to complete the setting.
- (4) Press **RUN**, and the system executes the program until reaching the specified line or label of the program.
- (5) The controller executes and records the execution status of the program blocks prior to the specified line. Then the controller stops at the break line for execution.
- (6) Press **CYCLE START** to execute the program.

Note:

1. When finding the target block, the system stops and remains unexecuted. Press **CYCLE START** to resume executing the program.
2. Supported formats for searching: line number and label (N number) of the program.
3. During program execution or the break line search function is used, any request for break line search will be ignored as the system regards it is in execution.



7

When the G-code program is executed, you can use the SF set function to change the cutting feedrate (F command) and spindle speed (S command) specified in the G-code program, as shown in Figure 7.16.4. Enter a new command value in the SF set dialog box to change the speed command during execution.

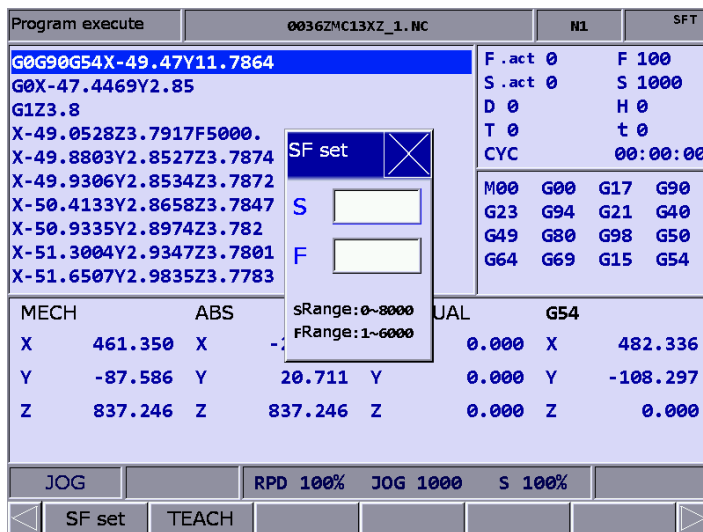

Figure 7.16.4

The operation steps are as follows.

- (1) In AUTO mode, press **PRG** to enter the program execution screen.
- (2) Press **SF set** and a dialog box appears for you to enter the command value.
- (3) Enter the S value or F value and press **ENTER** to complete changing the speed command setting.

Note:

1. The SF set function is a one-shot function with the S and F settings effective for one time in a single execution, which do not change the command settings in the G-code program.  
If requiring to execute this SF setting for multiple times, you are suggested to edit the command in EDIT mode to ensure the speed command is correct.
2. After the S value is set, the current spindle speed in the G-code program is changed immediately. After the F value is set, the system executes with the new feedrate (F command) after the data in the system buffer is completely processed.
3. If there is no S or F command in the G-code program, you cannot use this function to change the speed command.
4. When using the SF set function, set Pr10017 [Bit 3] SF speed setting to enable or disable the F setting.

The BARCODE function is for using the barcode scanner to load the machining files named by barcode into the file queue and execute them, which greatly saves the time for file searching. You can connect the barcode reader to the USB slot in the front size of the controller.

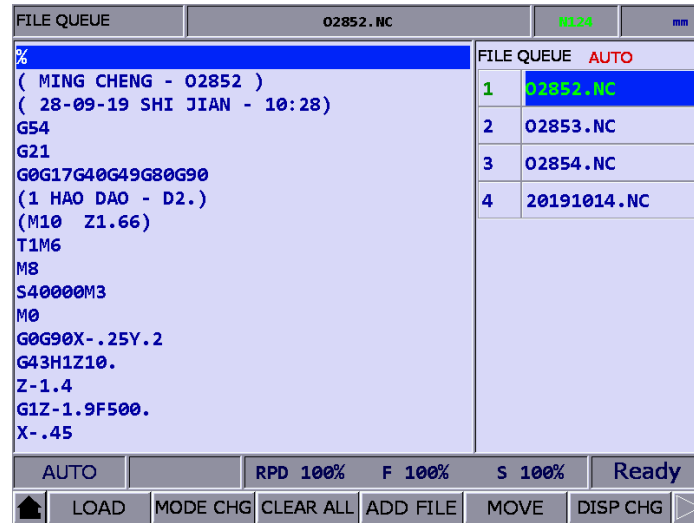

Figure 7.16.5

The operation steps are as follows.

- (1) In AUTO mode, press **PRG** to enter the program execution screen.
- (2) Press **BARCODE** to enter the screen as shown in Figure 7.16.5.
- (3) Use the barcode scanner to scan the barcode to obtain the name of the machining file.
- (4) To load the file content, press **LOAD**. To delete the file which is on the top of the FILE QUEUE list, press **CLEAR**. To delete all the files on the FILE QUEUE list, press **CLR ALL**.

Note:

1. To use this function, you must first create the machining files in the CF card and the file names have to be consistent with their barcodes.
2. When loading multiple files, the system executes each file in sequence. It automatically deletes the file name from the list once completing the execution.

### JOG and MPG modes:

The operation steps for SF setting are as follows.

- (1) In JOG or MPG mode, press **PRG** to enter the program execution screen.
- (2) Press **SF set** and a dialog box appears for you to enter the command value.
- (3) Enter the S value or F value and press **ENTER** to complete changing the speed command setting.

7

With the TEACH function, you can manually move the axis to any position and use the programming function keys, and the system can convert the final position (coordinates of the three axes) into a motion block with coordinates specified. Set the system to JOG or MPG mode, and you can use the TEACH function in the PRG screen for programming the existing or new files. Functions in the TEACH screen include: rapid traverse (POSITION), linear interpolation (LINEAR), circular interpolation (CIRCULAR), delete (DEL), file creating (NEW FILE), file saving (SAVE), and SET (selection of plane, coordinate, and axis). This TEACH function automatically generates corresponding command formats according to the different function options. See the following table for the generated command formats.

Function	Auto-generated command format
NEW FILE (generate a new file when teach programming is enabled)	G90 G40 G49 G98 G50 G64 G80 G17 G69 G21 G54 G15 S3000 M03 F1000 Note: this function generates the corresponding G21 or G20 command according to the parameter setting of the size unit.
POSITION (rapid traverse)	G00 + X_Y_Z_
LINEAR (linear interpolation)	G01 + X_Y_Z_
CIRCULAR (circular interpolation)	G02 + X_Y_Z_ + I_ J_ or G03 + X_Y_Z_ + I_ J_ Note: this function generates G17+I_ J_, G18+K_ I_, or G19+J_ K_ corresponding to the X-Y, Z-X, or Y-Z plane.
ABS (absolute coordinates)	G90 G00 (or G01 / G02 / G03) + X_Y_Z_
MECH (machine coordinates)	G53 G00 (or G01/G02/G03) + X_Y_Z_

The operation steps for the TEACH function are as follows.

- (1) In JOG or MPG mode, press **PRG** to enter the program execution screen.
- (2) Press **TEACH** to enter the teach screen.
- (3) Select the file to be programmed from the existing files or create a new file. If desiring to do programming in the existing file, open the file in EDIT mode. If you want to do programming in a new file, press **NEW FILE**, and a dialog box appears for you to enter the file name. Enter the file name, press **ENTER**, and you can create a new file in the current directory.
- (4) Specify the data type of coordinates. For example, if you desire to display absolute coordinates, press **ABS** on the second page of the function bar. Or press **MECH** to switch to machine coordinates.
- (5) Move the axis to the specified position in JOG or MPG mode, press **POSITION** or **LINEAR** according to the requirement of the mode, and the coordinate command is inserted to the position where the cursor is located. The coordinate command is generated according to the data type of the coordinate values.
- (6) Continued from Step (5), to specify a circular motion, press **CIRCULAR** to display the corresponding function bar.

- (7) Continued from Step (6), to specify the plane of the arc, press **SET** to select X-Y, Y-Z, or Z-X.
- (8) Move the axes in sequence and set the start, intermediate, and end points of the arc by pressing **P1**, **P2**, and **P3** respectively. After P3 is set, the values are automatically converted into a circular cutting command. The system determines the direction of the arc (G02 or G03) and the radius according to the trajectory of P1 - P3.
- (9) If the coordinate command is incorrect, move the cursor to the block and press **DEL** (on the function bar of the 1<sup>st</sup> layer in the teach screen) to delete the block.
- (10) After completing the programming, in addition to the given auto-saving mechanism (press **RESET**, switch to different system modes, or open another file), you can press **SAVE** to save the programming results.

Note:

1. The TEACH function is only available in JOG or MPG mode. It is not displayed in other modes.
2. The allowable file size for the teach function is the same as that for file editing (below 3 MB).
3. The name of the created file for the teach function must comply with the file name specification.
4. If you repeatedly enter two sets of coordinate with the same values, the system ignores the 2<sup>nd</sup> coordinate command to avoid generating an invalid motion block.
5. Set the coordinates of P1, P2, and P3 for the arc command in sequence. The direction and radius for the circular command is determined by the positions of P1, P2, and P3.
6. If you enter the teach screen without opening a file, the system automatically generates a blank file named "TEACH.NC" in the directory where the cursor is located (the default setting is to generate a file in the root directory of CF), so you can directly use the teach function.
7. When using the SF set function, set Pr10017 [Bit 3] SF speed setting to enable or disable the F setting.

7

**MDI mode**

In MDI mode, you can enter simple programs and save, delete, or execute the content in the PRG screen, as shown in the following figure. You can enter up to 14 program blocks in the screen. After finishing editing the program, press **LOAD** to reload and then execute the program. Otherwise, the program cannot be executed.

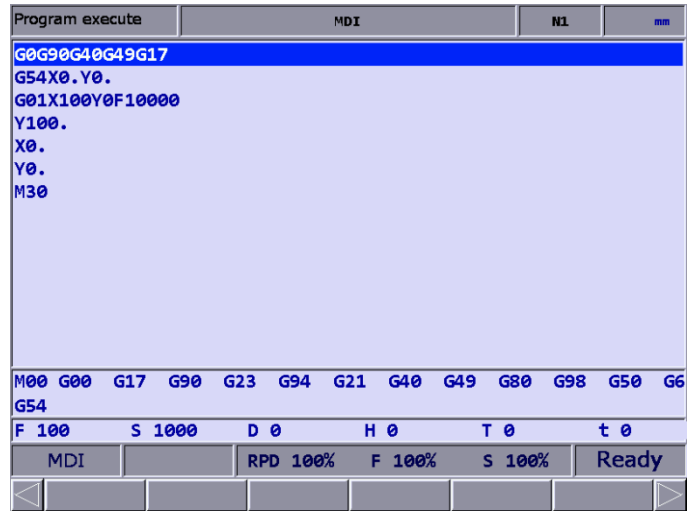

Figure 7.16.6

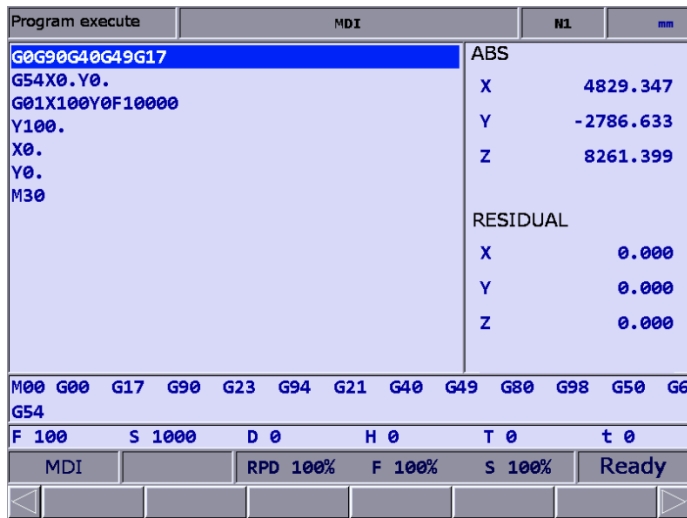

Figure 7.16.7

In addition, the SAVE function is for saving the program content entered in MDI mode as a file in the current directory. The naming method is the same as that in Section 7.2 Create a new file. That is, the file name has to follow the naming convention and be unique. The CLR function is for deleting all the program content in the screen in MDI mode, which functions the same as pressing and holding **RESET** (you can press and hold **RESET** for 3 seconds to delete all the content in the program screen).

Note:

1. In MDI mode, the **RESET** key has a two-stage function. Press **RESET** once to interrupt the execution and return to the first line of the manual input program. Press and hold **RESET** for 3 seconds to clear all the manual input program contents.
2. In MDI mode, after M30 is executed, the cursor returns to the first line of the program. You can resume the execution without reloading the program.
3. In MDI mode, if there is no M30 (Program end) command, the program runs to the last line. To resume the execution, press **LOAD** to reload the program.
4. In MDI mode, after M02 is executed, the cursor stops at the block of M02 and the program status restores to the default. And you can resume the execution from the block of M02 without reloading the program.

(This page is intentionally left blank.)

# 7

# Offset (OFS) group

# 8

The OFS group provides functions for setting the workpiece coordinates, tool length compensation, tool radius compensation, and macro variables.

---

8.1	Coordinate setting (COORD) .....	8-2
8.1.1	Auto set (AUTO) .....	8-3
8.1.2	Absolute input (ABS).....	8-7
8.1.3	Incremental input (INC) .....	8-9
8.1.4	Center of rectangle (SQUARE) .....	8-10
8.1.5	Center of circle (CIRCLE) .....	8-12
8.2	Tool setting (CUTTER) .....	8-14
8.2.1	Milling machine system .....	8-14
8.3	Tool magazine management (MAGA) .....	8-17
8.3.1	Multi-magazine management.....	8-22
8.4	Macro variables (MACRO).....	8-23
8.4.1	Local variables (LOCAL).....	8-23
8.4.2	Global variables (GLOBAL) .....	8-24
8.4.3	Non-volatile variables (HOLD).....	8-24
8.4.4	Extension variables (EXTEND) .....	8-24



# 8

The OFS group provides functions for setting the workpiece coordinates, tool length compensation, tool radius compensation, and macro variables.

Note: bold function names in a box (such as **POS**) mean the keys on machine operation panel A; bold function names (such as **CLR ALL**) mean the function keys of F1 - F6.

## 8.1 Coordinate setting (COORD)

G54 - G59 allow you to set multiple workpiece coordinate systems. With commands G54 - G59, you can simplify the calculation of coordinates during programming as well as change the coordinate values at any time, achieving more flexible machining process. You can specify the coordinate values in the coordinate setting screen with one of the workpiece coordinate commands (G54 - G59), as shown in the following figure.

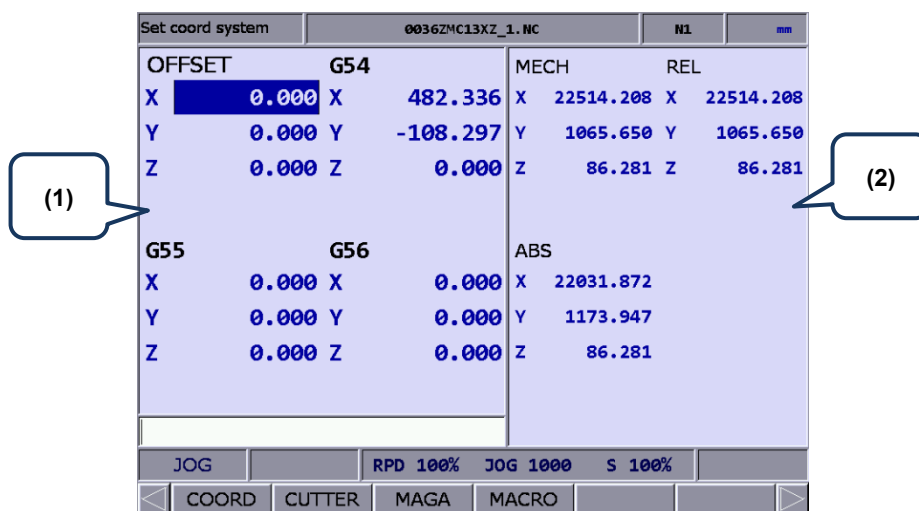

Figure 8.1.1

- (1) Workpiece coordinate setting: offset coordinates, G54 - G59 coordinate systems
- (2) Coordinate information: machine (MECH) / relative (REL) / absolute coordinates (ABS)

The operation steps are as follows.

- (1) Press **OFS** to enter the OFS screen.
- (2) Press **COORD** to display the corresponding function bar.

Note:

1. Set the coordinate systems only when there is no machining program being executed. Otherwise, data entry is prohibited.
2. If you press **FEED HOLD** during program execution, the system status remains "RUN". If you press







(Single block execution) during program execution, the execution stops after the current block is finished, and the system status becomes "Ready".

### 8.1.1 Auto set (AUTO)

This function is for automatically entering the current position of each axis to the coordinate system (G54 - G59) where the cursor is located. The auto set function includes three options: setting single axis (SET), setting multiple axes (SET P), and setting coordinate system center (SET L/2). The option of setting the coordinate system center must be used with the function of clearing relative coordinates (CLR REL). The function of clearing coordinate values of a coordinate system (CLR ALL) is also provided.





- CLR ALL (all clear): clears all the axis values of the current coordinate system to 0 while the values in other systems remain unchanged.

The operation steps are as follows.

- (1) Press **OFS** to enter the OFS screen.
- (2) Press **COORD** to display the corresponding function bar.
- (3) Press **AUTO** to display the corresponding function bar.
- (4) Press , , , and  to move the cursor to a specific coordinate system.
- (5) Press **CLR ALL** to delete all the data of the coordinate system.

- CLR REL (relative clear): clears the relative coordinates of the axis which the cursor is pointing to. This function is not used for clearing the actual workpiece coordinates but for clearing the displayed relative coordinates.

- SET L/2 (set center): this function is for setting the central position of an object as the center of a coordinate system. The NC system automatically calculates and enters the central position coordinates to the field, so you do not need to do it manually. The following operation steps take the X axis as an example.

- (1) Set the system to JOG or MPG mode and move the machine axis to the initial contact point of the workpiece in X-axis direction.
- (2) Press **OFS** to enter the OFS screen.
- (3) Press **COORD** to display the corresponding function bar.
- (4) Press **AUTO** to display the corresponding function bar.
- (5) Press , , , and  to move the cursor to the X-coordinate field of a specific coordinate system.
- (6) Press **SET L/2** to enter its setting screen.

8

- (7) Press **X1** and the circle on the left side of the rectangle becomes red, as shown in Figure 8.1.1.1, meaning the machine coordinates of the first point is recorded.

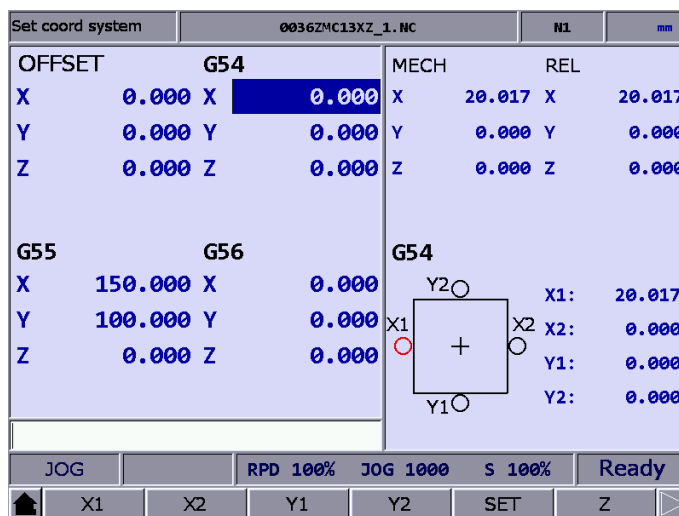

Figure 8.1.1.1

- (8) Continue to move the machine axis to the other contact point of the workpiece in X-axis direction.
- (9) Press **X2** and the circle labeled as X2 in Figure 8.1.1.1 becomes red, meaning the machine coordinates of the second point is recorded.
- (10) Press **SET** and the system automatically calculates the central point between the machine origin and the workpiece position in X-axis direction and sets this point as the center of X axis in the coordinate system, which is the workpiece origin of X axis.

- **SET L (set single axis):** this function is for automatically entering the current machine coordinate of a single axis. When you move the cursor to the X, Y, or Z field of a specific coordinate system and press **SET L**, the current machine coordinate is automatically entered to the field where the cursor is located. This function is for entering the data of a single axis at one time. The operation steps are as follows.
  - (1) Set the system to JOG or MPG mode and move the machine axis to the initial contact point of the workpiece in X-axis direction.
  - (2) Press **OFS** to enter the OFS screen.
  - (3) Press **COORD** to display the corresponding function bar.
  - (4) Press **AUTO** to display the corresponding function bar.
  - (5) Press **↑**, **↓**, **←**, and **→** to move the cursor to the X-coordinate field of a specific coordinate system.
  - (6) Press **SET L** to automatically enter the axis coordinate value in the field where the cursor is located.

#### Example of setting single axis

This example illustrates setting the X-axis value by moving the machine axis to a specific position (workpiece origin in X-axis direction as shown in Figure 8.1.1.2).

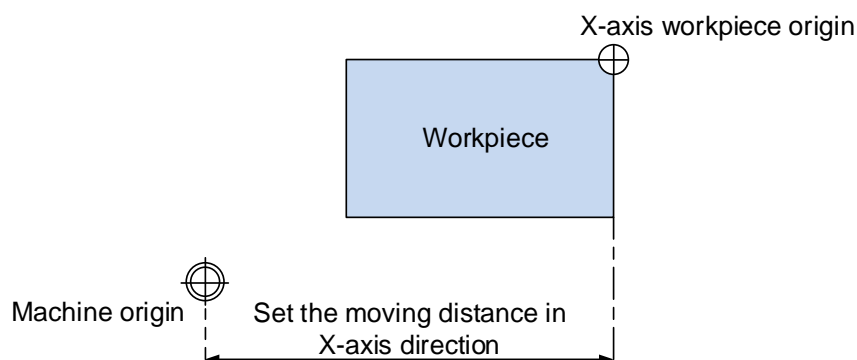

Figure 8.1.1.2

Then, the coordinate values are displayed in the machine coordinate fields as shown in Figure 8.1.1.3. Move the cursor to a specific coordinate system such as G54 as shown in Figure 8.1.1.3 and press **SET L** to automatically enter the X-axis value of the machine coordinates to the X-axis field in G54 coordinate system, completing the data entry for single axis.

8

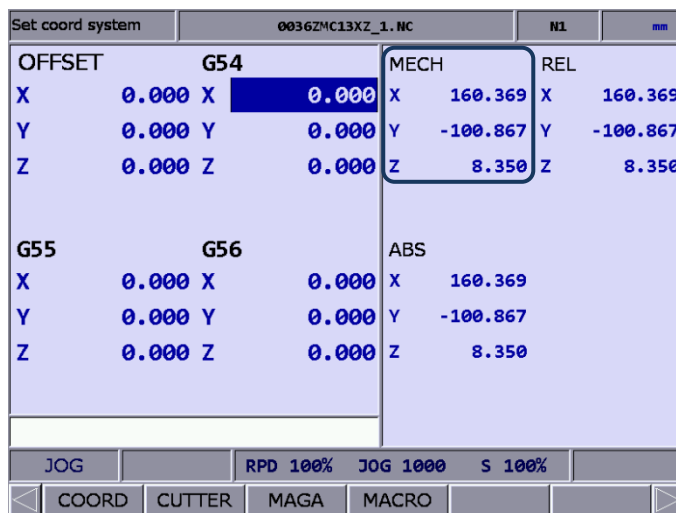

Figure 8.1.1.3

■ **SET P (set multiple axes):** this function is for automatically entering the coordinates of multiple axes. After completing the calibration of workpiece center, you can use this function to enter the machine coordinates of multiple axes (including X, Y, Z, and other axes) simultaneously. The operation steps are as follows.

- (1) Set the system to JOG or MPG mode and move the machine axis to the initial contact point of the workpiece in X-axis direction.
- (2) Press **OFS** to enter the OFS screen.
- (3) Press **COORD** to display the corresponding function bar.
- (4) Press **AUTO** to display the corresponding function bar.
- (5) Press **↑**, **↓**, **←**, and **→** to move the cursor to a specific coordinate system.
- (6) Press **SET P** to automatically enter the coordinate values of multiple axes in the coordinate system field where the cursor is located.

Note: if you have set the coordinates of other axes, do not press **CLR ALL** to clear the axis values, or the coordinate values are all cleared.

**Example of setting multiple axes**

Move the machine axis to the specified position as the workpiece origin shown in Figure 8.1.1.4 (the figure illustrates the position of X and Y axes except Z axis).

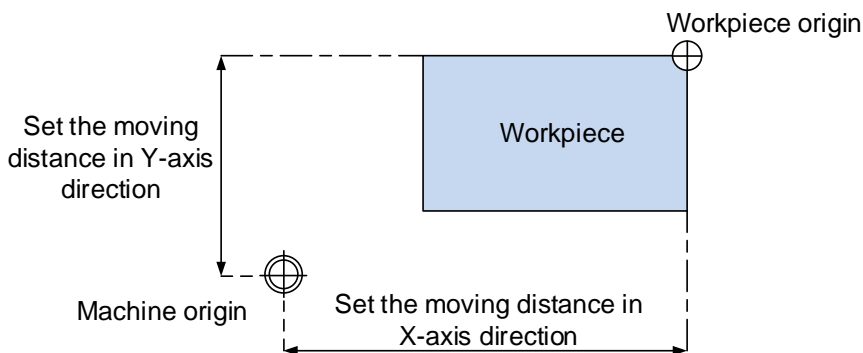

Figure 8.1.1.4

After completing the calibration of workpiece origin, the coordinate values are displayed in the machine coordinate fields as shown in Figure 8.1.1.5. Move the cursor to the G54 coordinate system and press **SET P** to automatically enter the values of X-, Y-, and Z-axis of the machine coordinate to the X-, Y-, and Z-axis fields in G54 coordinate system, completing the data entry for multiple axes.

Set coord system		0036ZMC13XZ_1.NC		N1		mm	
OFFSET		G54		MECH		REL	
X	0.000	X	0.000	X	160.369	X	160.369
Y	0.000	Y	0.000	Y	-100.867	Y	-100.867
Z	0.000	Z	0.000	Z	8.350	Z	8.350
G55		G56		ABS			
X	0.000	X	0.000	X	160.369		
Y	0.000	Y	0.000	Y	-100.867		
Z	0.000	Z	0.000	Z	8.350		
JOG		RPD 100%		JOG 1000		S 100%	
COORD		CUTTER		MAGA		MACRO	

Figure 8.1.1.5

### 8.1.2 Absolute input (ABS)

One of the manual input function for coordinate values, which includes absolute and incremental settings. The following operation steps illustrate the absolute setting.

- (1) Press **OFS** to enter the OFS screen.
- (2) Press **COORD** to display the corresponding function bar.
- (3) Press **↑**, **↓**, **←**, and **→** to move the cursor to a specific coordinate system.
- (4) To enter positive values, simply press **0** - **9**; to enter negative values, you have to press **[-]** before using the numeral keys. After entering the values, press **[.]** to determine the number of decimal places.
- (5) Press **ABS** to enter absolute coordinates to the coordinate system.

Note:

1. The displayed values are in the unit of mm. If you enter values without specifying the decimal points, they are in the unit of  $\mu\text{m}$ . For example: when you enter 123456, it refers to 123456  $\mu\text{m}$ , so the result is 123.456 mm.
2. In Step (5), you can press either **ABS** or **ENTER** to enter the coordinates.

8

Example of absolute setting

Move the tool center from the machine origin to the workpiece origin (X, Y). Then, enter the machine coordinates of X- and Y-axis corresponding to the workpiece origin to the coordinate system (G54 - G59) in the **OFS** group.

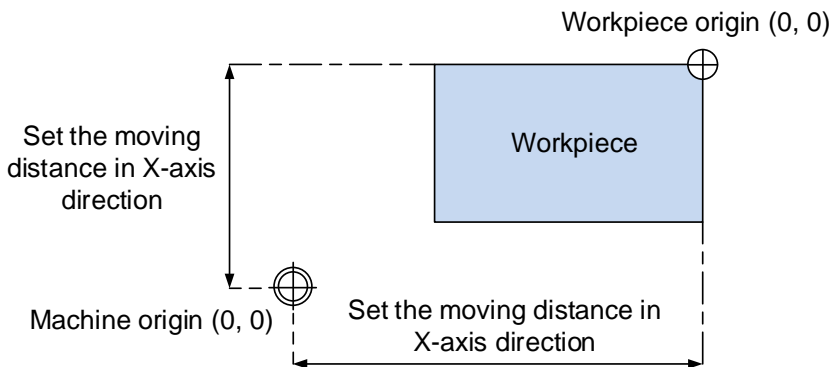

Figure 8.1.2.1









Set coord system		0036ZMC13XZ_1.NC		M1		mm	
OFFSET G54				MECH REL			
X	0.000	X	0.000	X	160.369	X	160.369
Y	0.000	Y	0.000	Y	-100.867	Y	-100.867
Z	0.000	Z	0.000	Z	8.350	Z	8.350
G55				ABS			
X	150.000	X	0.000	X	160.369		
Y	100.000	Y	0.000	Y	-100.867		
Z	0.000	Z	0.000	Z	8.350		
G56							
X	0.000	X	0.000				
Y	0.000	Y	0.000				
Z	0.000	Z	0.000				
JOG		RPD 100%		JOG 1000		S 100%	
Ready		COORD		CUTTER		MAGA	
		MACRO					

Figure 8.1.2.2

### 8.1.3 Incremental input (INC)

One of the manual input function for coordinate values, usually used for fine adjustment of the original value. That is, you change the values incrementally. For example, when the original value is 150.000, if you enter 5.000 by incremental setting, the newly-set value is 155.000.

The operation steps are as follows.

- (1) Press **OFS** to enter the OFS screen.
- (2) Press **COORD** to display the corresponding function bar.
- (3) Press , , , and  to move the cursor to the X, Y, or Z axis field of a specific coordinate system.
- (4) To enter positive values, simply press  - ; to enter negative values, you have to press  before using the numeral keys. After entering the values, press  to determine the number of decimal places.
- (5) Press **INC** to increment the coordinate values.

Note: make sure you use the correct mode (ABS or INC) and enter the correct coordinates to avoid danger caused by incorrect axis movement.



8

### 8.1.4 Center of rectangle (SQUARE)

The rectangular diagram on the screen can guide users in setting the coordinates for the center of rectangular objects. After the system converts the data of the four set endpoints, it calculates the coordinates for the actual center of the object. The function screen is as shown in the following figure.

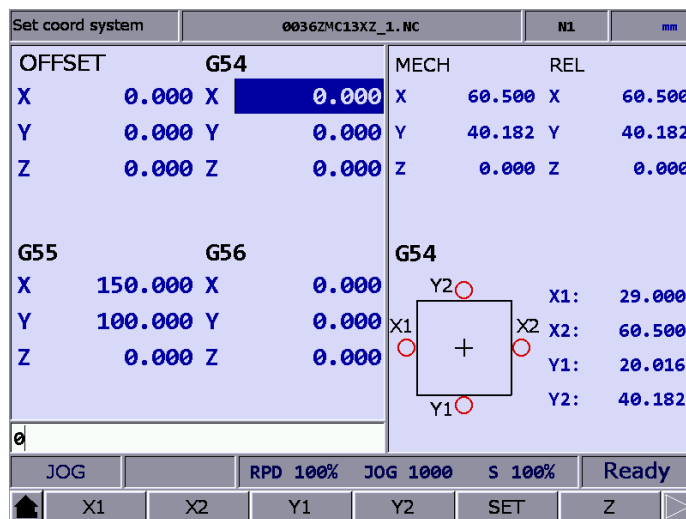

Figure 8.1.4.1

The operation steps are as follows.

- (1) Press **OFS** to enter the OFS screen.
- (2) Press **COORD** to display the corresponding function bar.
- (3) Press **↑**, **↓**, **←**, and **→** to move the cursor to the data field of a specific coordinate system.
- (4) Press **SQUARE** to display the corresponding function screen.
- (5) Follow the instructions on the schematic and move the center of the spindle to the mechanical positions of X1, X2, Y1, and Y2. Press the **X1**, **X2**, **Y1**, and **Y2** function keys to set the coordinates of each point.
- (6) After setting the coordinates of the 4 points on the rectangle, press **SET** and the system will calculate the coordinate data for the center of the rectangle, and enter it into the coordinate system automatically.
- (7) Move the Z axis and confirm the coordinate position, and then press **Z** to complete the Z axis coordinate settings for that workpiece coordinate group.

Center of rectangle application examples

First, specify the coordinate group field; move the spindle to the 4 endpoint positions of the object manually, and enter the X and Y data for the 4 positions respectively using the corresponding function keys as shown in Figure 8.1.4.2.

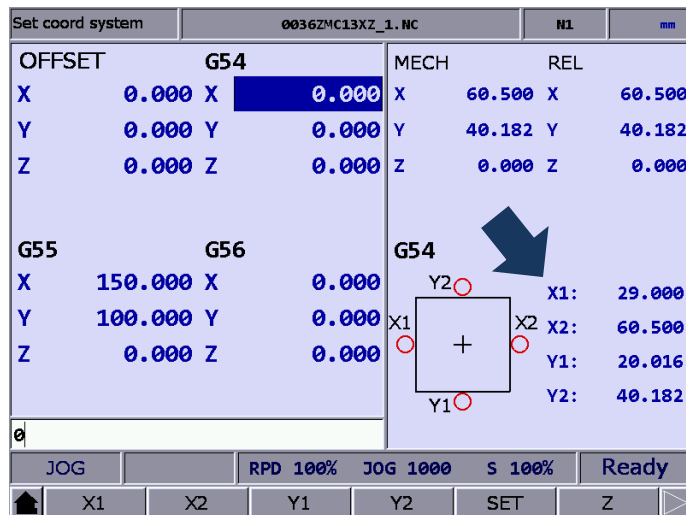

Figure 8.1.4.2

After completing the coordinate settings for the 4 endpoints of the rectangle, press **SET**, and the system will calculate the actual machine coordinate values that corresponds to the center of the rectangular object automatically, and complete the data setting for the specified coordinate system automatically as shown in Figure 8.1.4.3.

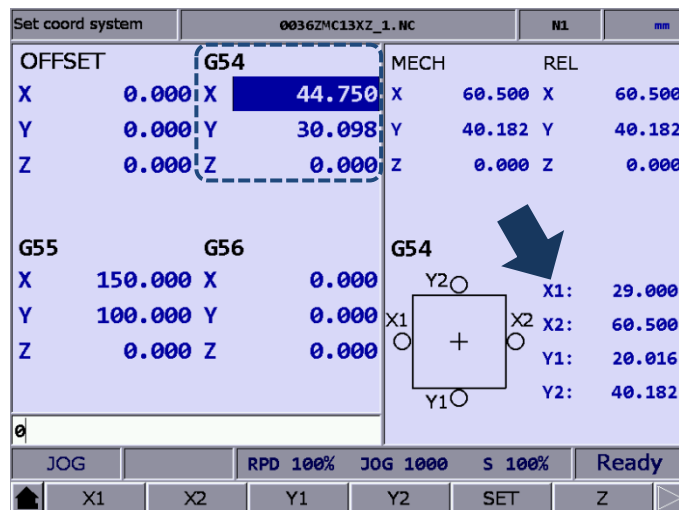

Figure 8.1.4.3

8

8.1.5 Center of circle (CIRCLE)

This function can set the coordinate data for the center of a round object. You can use this function to select any three positions on a round object and set the coordinate data of those three points at the same time; then the coordinates for the center of that object are calculated automatically. The function screen is as shown in the following figure.

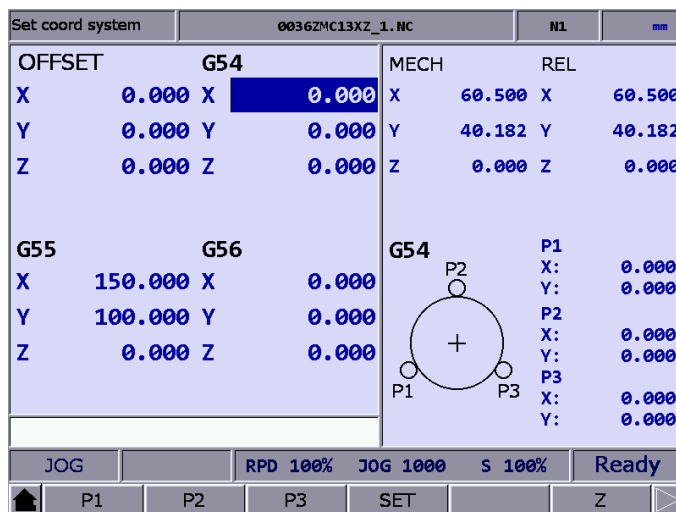

Figure 8.1.5.1

The operation steps are as follows.

- (1) Press **OFS** to enter the OFS screen.
- (2) Press **COORD** to display the corresponding function bar.
- (3) Press **↑**, **↓**, **←**, and **→** to move the cursor to the data field of a specific coordinate system.
- (4) Press **CIRCLE** to display the corresponding function screen.
- (5) Follow the schematic and move the center of the spindle to the mechanical positions of P1, P2, and P3 in sequence, and then press **P1**, **P2**, and **P3** function keys to set them in sequence.
- (6) After setting the coordinates of the three points on the circle, press **SET**, and the system will calculate the coordinate data for the center of the circle, and enter it into the coordinate system automatically.
- (7) Move the Z axis and confirm the coordinate position, press **Z** to complete the Z axis coordinate settings for that workpiece coordinate group.

Center of circle application examples

You can use the CIRCLE function when the workpiece is a round object. Operate the spindle manually to touch any 3 points on the circumference, and set the coordinates of these 3 points individually using the corresponding function keys as shown in Figure 8.1.5.2.

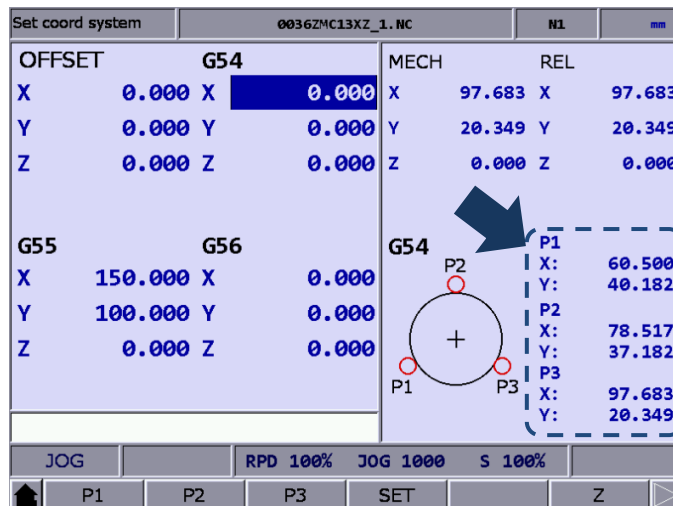

Figure 8.1.5.2

After entering the coordinates of any 3 points on the circumference, press **SET**, and the system will calculate the machine coordinates for the center of the circle automatically and enter this data into the specific coordinate system group as shown in Figure 8.1.5.3.

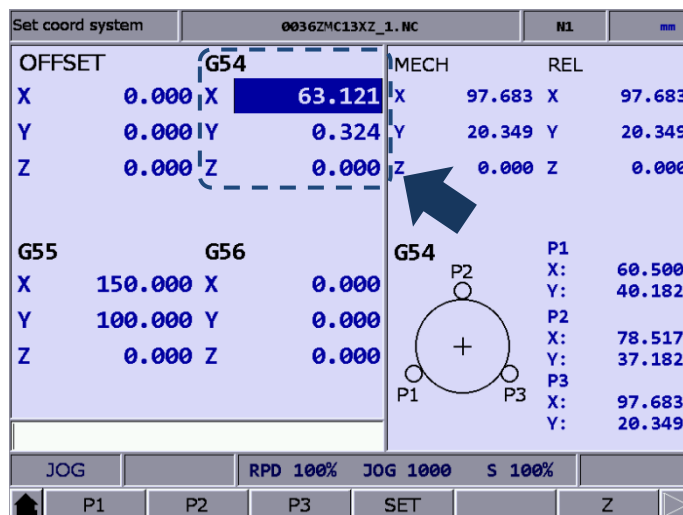

Figure 8.1.5.3

# 8

## 8.2 Tool setting (CUTTER)

### 8.2.1 Milling machine system

The tool setting function must be used with G code command to specify whether to compensate the tool length (compensate with G43 or G44; cancel with G49) or whether to compensate the tool radius (compensate with G41 or G42; cancel with G40). Functions of tool setting for the milling machine system include tool length compensation, tool radius compensation, tool length wear compensation, tool radius wear compensation, and tool life management.

The data fields correspond to the H and D numbers specified in the machining program. H represents tool length compensation and D represents tool radius compensation. With the tool setting function, you can specify the tool length or tool radius data freely and generate the planned machining path and dimensions without modifying the program path. The value setting functions include ABS, INC, SET H, and CLEAR. The tool compensation function screen is as shown in the following figure.

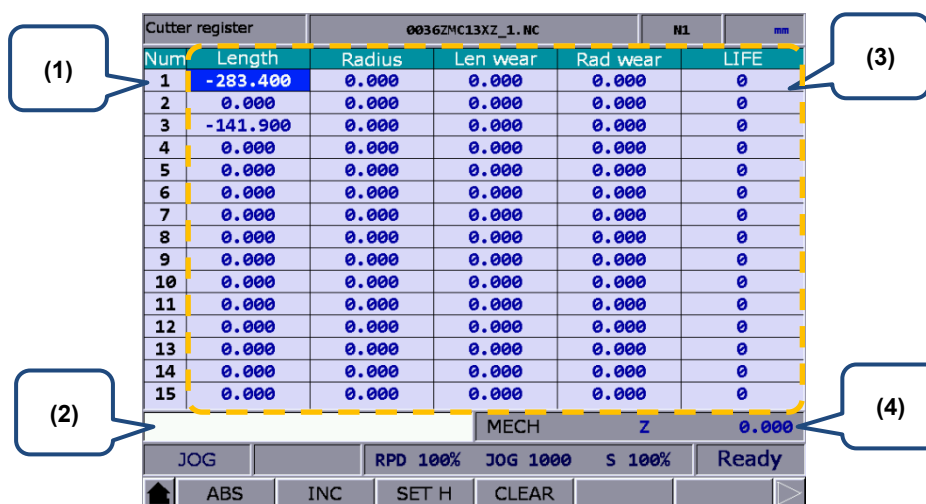

Figure 8.2.1.1

- (1) Compensation number (H / D)
- (2) Input field for compensation data
- (3) Compensation information: tool length, tool radius, length wear compensation, radius wear compensation, and tool life
- (4) Auxiliary display: current machine coordinates of the Z axis

Tool setting data value range	
Tool length data	-2000.0 to +2000.0 mm
Tool radius data	-150.0 to +150.0 mm
Compensation data for tool length wear	-2000.0 to +2000.0 mm
Compensation data for tool radius wear	-150.0 to +150.0 mm
Tool life data	0 to 99999999 times

- **ABS** (absolute input): one of the manual input function for coordinate values. You can use this function to set absolute values for tool length, tool radius, tool wear compensation, or tool life. You can also press **ENTER** to set absolute values. The operation steps are as follows.

- (1) Press **OFS** to enter the OFS screen.
- (2) Press **CUTTER** to enter the corresponding function screen.
- (3) Use **↑**, **↓**, **←** and **→** to move the cursor to specific data field of tool length, tool radius, tool wear, or tool life.
- (4) To enter positive values, simply press **0** - **9**; to enter negative values, you have to press **-** before using the numeral keys. After entering the values for the tool compensation data, press **°>** to confirm the unit of the values. If it is the data value for tool life, the set value must be positive integers.
- (5) Press **ABS** to set the value using absolute data.

Note: the tool data fields correspond to different compensation data. For example: when the cursor is on the length field, the data entered is the tool length compensation data.

- **INC** (incremental input): one of the manual input function for coordinate values. You can use this function to set incremental values for tool length, tool radius, tool wear compensation, and tool life.
- (1) Press **OFS** to enter the OFS screen.
  - (2) Press **CUTTER** to enter the corresponding function screen.
  - (3) Use **↑**, **↓**, **←** and **→** to move the cursor to specific data field of tool length, tool radius, tool wear, or tool life.
  - (4) To enter positive values, simply press **0** - **9**; to enter negative values, you have to press **-** before using the numeral keys. After entering the values for the tool compensation data, press **°>** to confirm the unit of the values. If it is the data value for tool life, the set value must be positive integers.
  - (5) Press **INC** to increase or decrease the value of that field.

## 8

- **SET H:** a dedicated function for automatically entering the tool length compensation value (H). The Z axis height of the current machine coordinates can be entered automatically to the specified tool length compensation data field. This function avoids the risk of entering incorrect values and shortens the setting time. The operation steps are as follows.

- (1) In JOG or MPG modes, operate and move the Z axis of the machine to the specified coordinate height.
- (2) Press **OFS** to enter the OFS screen.
- (3) Press **CUTTER** to enter the corresponding function screen.
- (4) Press **↑**, **↓**, **←**, and **→** to move the cursor to the tool length field of a specific number.
- (5) Press **SET H** to set the Z axis machine coordinate values in the specified data field automatically.

Note:

1. The SET H function is only valid for the tool length data field; it has no effects on other fields.
2. During program execution, changing the values in the OFS group is prohibited. Values can only be entered when the program is stopped, such as the conditions of when no program is in execution, when the block with the single block execution function is complete, and when **RESET** is pressed.
3. When SET H is used to enter tool length data, the length wear value of that row will be cleared to 0.

- **CLEAR:** the clear function is used to clear the tool compensation data. The clear function includes options such as H/D, WEAR, LIFE, and ALL.

H/D: clears all tool length and radius data.

WEAR: clears all length wear and radius wear data.

LIFE: clears all tool life data.

ALL (clear all): clears all tool setting data.

The operation steps are as follows.

- (1) Press **OFS** to enter the OFS screen.
- (2) Press **CUTTER** to enter the corresponding function screen.
- (3) Press **CLEAR** to display the corresponding function bar.
- (4) Press **H/D** to clear tool length and tool radius data. Press **WEAR** to clear the tool wear compensation data. Press **LIFE** to clear all tool life data. Press **ALL** to clear all data fields.

### 8.3 Tool magazine management (MAGA)

This function is for managing the tool positions and their corresponding tool pot numbers after tool change. When a different tool is used, the tool pot positions and the corresponding tool numbers are recorded in the tool magazine data table.

You can view the recorded tool number corresponding to the tool pot positions and also change the sequence of the tool number in the tool magazine data table. With parameter settings, you can enable the multi-magazine management function. The function of tool magazine management is only available in JOG mode, as shown in the following figure.

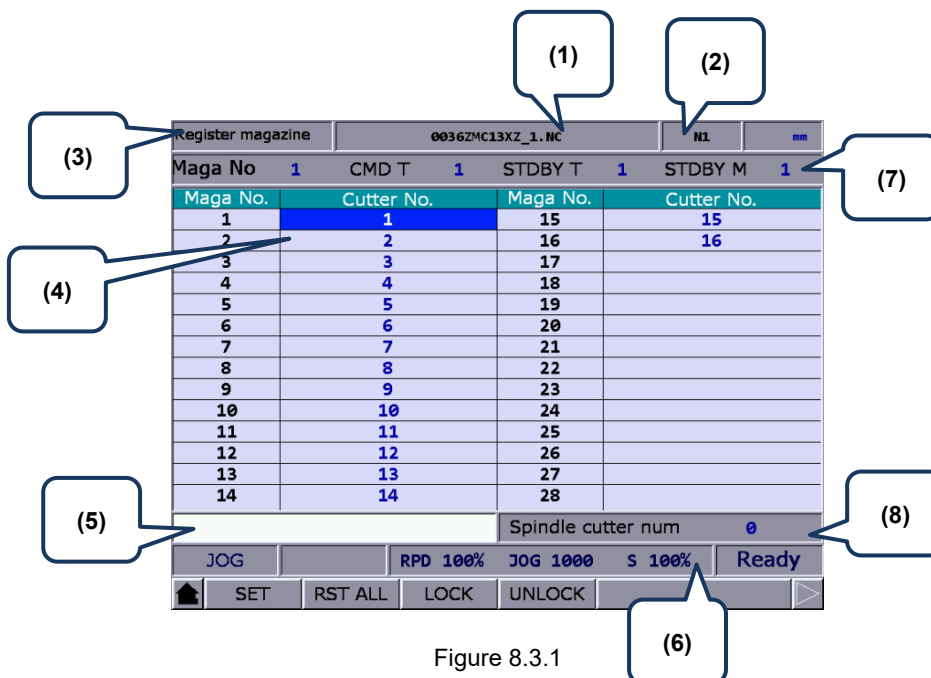

Figure 8.3.1

- (1) Name of current program
- (2) Currently executed program line
- (3) Current group function
- (4) Sequence of tool number
- (5) Tool number input field
- (6) Current override settings
- (7) Number of tool magazine system
- (8) Spindle tool number

The operation steps for tool magazine setting are as follows.

- (1) Set the system to JOG mode.
- (2) Press **OFS** to enter the OFS screen.
- (3) Press **MAGA** to enter the tool magazine data setting screen.
- (4) Press **↑**, **↓**, **←**, and **→** to move the cursor to a specific field.
- (5) Enter the tool number and press **SET** (or **ENTER**) to change its corresponding tool pot.



8

Example of changing tool number

When you specify a number that already exists in the data table, the system automatically exchanges the one to be replaced with the one that is repeated. This is for ensuring that the tool numbers in each address of the tool magazine do not overlap, preventing the tool call error.

Workflow description:

Register magazine		0036ZMC13XZ_1.NC		NL	mm
Maga No	1	CMD T	1	STDBY T	1
Maga No.	Cutter No.	Maga No.	Cutter No.		
1	1	15	15		
2	2	16	16		
3	3	17			
4	4	18			
5	5	19			
6	6	20			
7	7	21			
8	8	22			
9	9	23			
10	10	24			
11	11	25			
12	12	26			
13	13	27			
14	14	28			
				Spindle cutter num	0
JOG		RPD 100%	JOG 1000	s 100%	Ready
SET	RST ALL	LOCK	UNLOCK		

- (1) Initial status of the tool magazine. Tool numbers are arranged in sequence in accordance with the tool pot numbers.

Register magazine		0036ZMC13XZ_1.NC		NL	mm
Maga No	1	CMD T	1	STDBY T	2
Maga No.	Cutter No.	Maga No.	Cutter No.		
1	2	15	15		
2	1	16	16		
3	3	17			
4	4	18			
5	5	19			
6	6	20			
7	7	21			
8	8	22			
9	9	23			
10	10	24			
11	11	25			
12	12	26			
13	13	27			
14	14	28			
				Spindle cutter num	0
JOG		RPD 100%	JOG 1000	s 100%	Ready
SET	RST ALL	LOCK	UNLOCK		

- (2) If you set the tool number of tool pot 1 to 2, then the tool number of tool pot 2 becomes 1. That is, the tool numbers for tool pots 1 and 2 are exchanged.

Register magazine		0036ZMC13XZ_1.NC		NL	mm
Maga No	1	CMD T	1	STDBY T	2
Maga No.	Cutter No.	Maga No.	Cutter No.		
1	2	15	15		
2	1	16	16		
3	5	17			
4	4	18			
5	3	19			
6	6	20			
7	7	21			
8	8	22			
9	9	23			
10	10	24			
11	11	25			
12	12	26			
13	13	27			
14	14	28			
				Spindle cutter num	0
JOG		RPD 100%	JOG 1000	s 100%	Ready
SET	RST ALL	LOCK	UNLOCK		

- (3) If you set the tool number of tool pot 3 to 5, then the tool number of tool pot 5 becomes 3. That is, the tool numbers for tool pots 3 and 5 are exchanged.

According to the above examples, the mechanism of tool number change can avoid the possibility of mistakenly calling the incorrect tool number.

- **RST ALL (reset all):** the tool magazine management provides the function of resetting the tools by rearranging the tool numbers. After resetting, the records of changes in tool number are cleared. The tool numbers are arranged in sequence according to the tool pot numbers. With this function, you can restore the data to default setting for troubleshooting tool number misplacement or for tool number resetting. The operation steps are as follows.

  - (1) Set the system to JOG mode.
  - (2) Press **OFS** to enter the OFS screen.
  - (3) Press **MAGA** to enter the tool magazine data setting screen.
  - (4) Press **RST ALL** to reset the tool magazine data table.
  
- **LOCK (tool pot lock):** use this function to lock the spare tool pots. Tools in the locked pots cannot be called. If you use a command in the program to call a locked tool, the system enables the protection mechanism and displays an error message to stop the execution. This function is a preventive mechanism for checking the tool status during program execution, avoiding errors caused by incorrect tool call, such as damage to the latch of the tool magazine or interference to the magazine due to adjacent tools of large diameter. The data fields of the locked pots are highlighted with different colors. The operation steps are as follows.

  - (1) Set the system to JOG mode.
  - (2) Press **OFS** to enter the OFS screen.
  - (3) Press **MAGA** to enter the tool magazine data setting screen.
  - (4) Press **↑**, **↓**, **←**, and **→** to move the cursor to a specific tool number data field.
  - (5) Press **LOCK** to lock that pot, as shown in Figure 8.3.2.

Register magazine		0036ZMC13XZ_1.NC		N1	mm
Maga No	1	CMD T	1	STDBY T	1
				STDBY M	1
Maga No.	Cutter No.	Maga No.	Cutter No.		
1	1	15	15		
2	2	16	16		
3	3	17			
4	4	18			
5	5	19			
6	6	20			
7	7	21			
8	8	22			
9	9	23			
10	10	24			
11	11	25			
12	12	26			
13	13	27			
14	14	28			
				Spindle cutter num	0
JOG		RPD 100%	JOG 1000	S 100%	
↑	SET	RST ALL	LOCK	UNLOCK	→

Figure 8.3.2

8

Example of locking the tool pot

This function is used for preventing the tool of large diameter from damaging its adjacent tools by blocking the adjacent pots, ensuring the machine will not be damaged due to misoperation by personnel. By blocking the pots adjacent to the pot which carries a tool of large diameter, you can avoid executing inappropriate tool call program and thus prevent the possible collision caused by placing tools into the adjacent pots.

Register magazine		0036ZMC13XZ_1.WC		H1	mm
Maga No.	Cutter No.	Maga No.	Cutter No.		
1	1	15	15		
2	2	16	16		
3	3	17			
4	4	18			
5	5	19			
6	6	20			
7	7	21			
8	8	22			
9	9	23			
10	10	24			
11	11	25			
12	12	26			
13	13	27			
14	14	28			
				Spindle cutter num 0	
JOG		RPD 100%	JOG 1000	s 100%	Ready
SET	RST ALL	LOCK	UNLOCK		

Figure 8.3.3

Assume that T1 is a tool of large diameter and the adjacent tools are T2 and T16, you can prevent T1 from interfering with the adjacent tools by locking T2 and T16, as shown in the above figure.

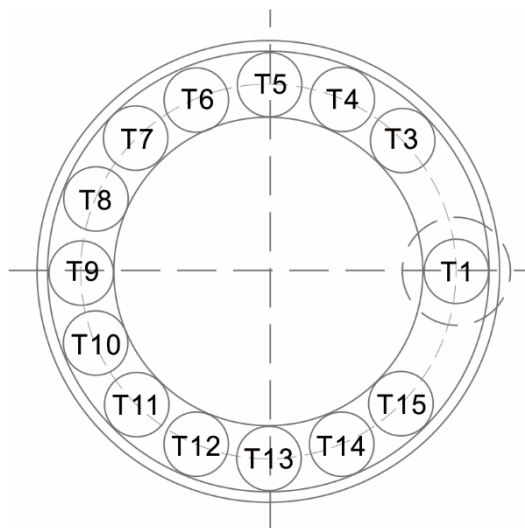





Figure 8.3.4

If T1 is a tool of large diameter, its interference with adjacent tools is as shown in the figure above. With T2 and T16 locked, you cannot call tools in the two tool pots.

- **UNLOCK (tool pot unlock):** you can use this function to unlock the pots. The operation steps are as follows.
  - (1) Set the system to JOG mode.
  - (2) Press **OFS** to enter the OFS screen.
  - (3) Press **MAGA** to enter the tool magazine data setting screen.
  - (4) Press , , , and  to move the cursor to the tool pot data field which has been locked.
  - (5) Press **UNLOCK** to unlock the tool pot. Or you can enter the same tool number to the data field of the locked pot and press **ENTER** to unlock.

8

### 8.3.1 Multi-magazine management

In response to the application needs for managing multiple tool magazines, you can enable this function with tool magazine parameters after accessing the security authorization. You can specify the number of tool pots for each tool magazine system according to the tool magazine specification as well as the tool numbers after resetting the tool magazine. The items MAGA1 and MAGA2 on the function bar are for dividing the management of the two different tool magazine systems. Contact the distributors for services of the multi-magazine management function.

Register magazine	0036ZMC13XZ_1.NC			N1	mm
Maga No	1	CMD T	1	STDBY T	1
Maga No.	Cutter No.	Maga No.	Cutter No.		
1	1	15	15		
2	2	16	16		
3	3	17			
4	4	18			
5	5	19			
6	6	20			
7	7	21			
8	8	22			
9	9	23			
10	10	24			
11	11	25			
12	12	26			
13	13	27			
14	14	28			
				Spindle cutter num	0
JOG		RPD 100%	JOG 100%	S 100%	
HOME	SET	RST ALL	LOCK	UNLOCK	RIGHT

Figure 8.3.1.1

Note:

1. You can set the tool numbers only when the system is in JOG mode. Otherwise, the corresponding function bar is not displayed.
2. You have to access the security authorization in advance before setting or resetting the tool numbers.
3. Tool numbers in the same tool magazine system cannot be repeated. If you specify a number which already exists in the magazine, the system automatically changes the existing one with a non-repeating number. This is for ensuring the tool numbers in each address of the magazine do not overlap, preventing the tool call error.
4. The default spindle tool number is T0. Once tool T0 is placed into the tool magazine, its position in the magazine is recorded as T0 and cannot be locked. That is, when the displayed tool number is "0", the LOCK function is disabled, and a dialog box appears and displays "T0 can't be locked!".

## 8.4 Macro variables (MACRO)

Using commands with variables, you can modify values, perform conditional operations, and input or output MLC data during program execution. There are four types of macro variables: local, global, non-volatile, and extension variables, with the data type as double word.

Macro var-local		0036ZMC13XZ_1.NC		H1	mm
No.	Value	No.	Value		
1	0.000	16	0.000		
2	0.000	17	0.000		
3	0.000	18	0.000		
4	0.000	19	0.000		
5	0.000	20	0.000		
6	0.000	21	0.000		
7	0.000	22	0.000		
8	0.000	23	0.000		
9	0.000	24	0.000		
10	0.000	25	0.000		
11	0.000	26	0.000		
12	0.000	27	0.000		
13	0.000	28	0.000		
14	0.000	29	0.000		
15	0.000	30	0.000		

JOG		RPD 100%	JOG 1000	S 100%	
HOME	LOCAL	GLOBAL	HOLD	EXTEND	▶

Figure 8.4.1

### 8.4.1 Local variables (LOCAL)

In macro programs, local variables (#1 - #50) are available in the current program.

The operation steps are as follows.

- (1) Press **OFS** to enter the OFS screen.
- (2) Press **MACRO** to display the variable entry screen.
- (3) Press **LOCAL** and the screen is automatically switched to display the variable table starting with number 1.
- (4) Press **↑**, **↓**, **←**, and **→** to move the cursor to a specific variable data field.
- (5) Enter the value and press **ENTER** to complete the setting.

## 8

### 8.4.2 Global variables (GLOBAL)

Global variables (#51 - #250) are shared by main programs, subprograms, and macro programs.

The operation steps are as follows.

- (1) Press **OFS** to enter the OFS screen.
- (2) Press **MACRO** to display the variable entry screen.
- (3) Press **GLOBAL** and the screen is automatically switched to display the variable table starting with number 51.
- (4) Press **↑**, **↓**, **←**, and **→** to move the cursor to a specific variable data field.
- (5) Enter the value and press **ENTER** to complete the setting.

### 8.4.3 Non-volatile variables (HOLD)

Non-volatile variables (#1601 - #1800) are for retaining the system status when power is off.

The operation steps are as follows.

- (1) Press **OFS** to enter the OFS screen.
- (2) Press **MACRO** to display the variable entry screen.
- (3) Press **HOLD** and the screen is automatically switched to display the variable table starting with number 1601.
- (4) Press **↑**, **↓**, **←**, and **→** to move the cursor to a specific variable data field.
- (5) Enter the value and press **ENTER** to complete the setting.

### 8.4.4 Extension variables (EXTEND)

Up to 500 extension variables (#10001 - #10500) are available for the system.

The operation steps are as follows.

- (1) Press **OFS** to enter the OFS screen.
- (2) Press **MACRO** to display the variable entry screen.
- (3) Press **EXTEND** and the screen is automatically switched to display the variable table starting with number 10001.
- (4) Press **↑**, **↓**, **←**, and **→** to move the cursor to a specific variable data field.
- (5) Enter the value and press **ENTER** to complete the setting.

# Diagnosis (DGN) Group

The DGN group provides functions of machining information, user variables, system monitoring, and parameter importing / exporting, which help you to optimize the system.

9.1	Machining information (PROCESS) .....	9-2
9.2	User variable (USR VAR) .....	9-4
9.3	MLC .....	9-5
9.3.1	Bit (BIT) .....	9-5
9.3.2	Register (REG) .....	9-7
9.3.3	Device monitoring (DEV MON) .....	9-8
9.3.4	Line search (JUMP TO) .....	9-10
9.3.5	Editor (EDITOR) .....	9-10
9.3.6	Operation (SET) .....	9-13
9.4	System monitoring (SYS MON) .....	9-14
9.4.1	Servo monitoring (SRV MON) .....	9-14
9.4.2	I/O monitoring (I/O MON) .....	9-14
9.4.3	Variable monitoring (VAR MON) .....	9-15
9.5	Password setting (PWD) .....	9-17
9.5.1	System security (S SCP) .....	9-17
9.5.2	Machine security (M SCP) .....	9-18
9.5.3	User security (User SCP) .....	9-21
9.5.4	Expiration time (EXPIRE) .....	9-22
9.6	System information (STATUS) .....	9-25
9.7	Gain tuning (TUNING) .....	9-26
9.8	Import (IMPORT) .....	9-29
9.9	Export (EXPORT) .....	9-31
9.10	Multi-language (TEXT WR) .....	9-33
9.11	LOGO (LOGO WR) .....	9-33



# 9

The DGN group includes a variety of functions. Machining information, user variables, system monitoring, gain adjustment, and system information are for optimizing the system. MLC diagnosis is for monitoring the current status of the MLC devices in the system. Password setting allows you to assign security authorization for different system functions. In addition, system parameters can be imported and exported.

Note: **Function names** in a box (such as **POS**) mean the keys on machine operation panel A; bold **function names** (such as **CLR ALL**) mean the function keys of F1 - F6.

## 9.1 Machining information (PROCESS)

You can set the number of machined workpiece and number of workpiece to be machined, as well as clear the machining time and number of machined workpieces. The screen of PROCESS is as shown in the following figure.

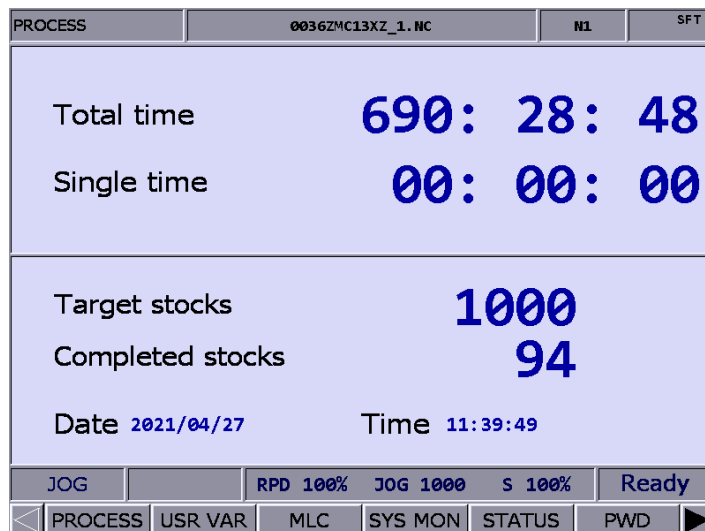

Figure 9.1.1

The operation steps are as follows.

- (1) Press **DGN** to enter the DGN screen.
- (2) Press **PROCESS** to enter the machining information screen.
- (3) Press **SET NR** and a dialog box appears for you to enter the number of machining workpiece as shown in the following figure.

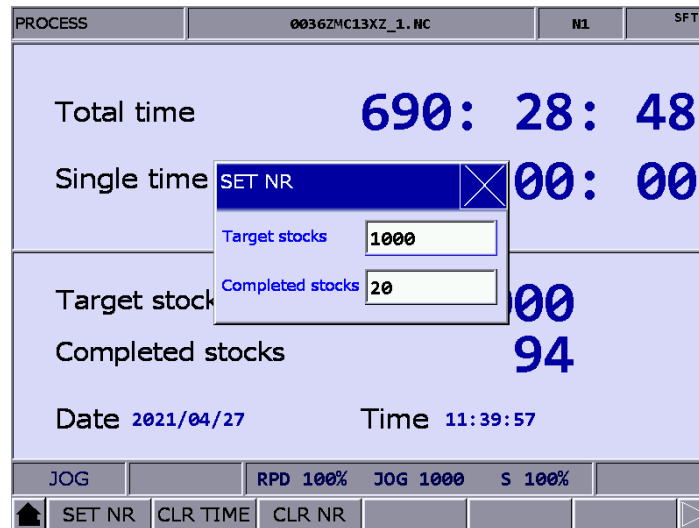

Figure 9.1.2

- (4) Press and to move the cursor to a specific field.
- (5) Enter a value within the range of 0 - 9999. Press **ENTER** to complete the setting.

In addition, you can clear the current machining time and number of machined workpiece on the machining information screen. The operation steps for clearing the machining time are as follows.

- (1) Press **DGN** to enter the DGN screen.
- (2) Press **PROCESS** to enter the machining information screen.
- (3) Press **CLR TIME** and a dialog box appears for confirmation.
- (4) Enter "Y" and press **ENTER** to clear the machining time for a single workpiece on the screen.

The operation steps for clearing the number of machined workpiece are as follows.

- (1) Press **DGN** to enter the DGN screen.
- (2) Press **PROCESS** to enter the machining information screen.
- (3) Press **CLR NR** and a dialog box appears for confirmation.
- (4) Enter "Y" and press **ENTER** to clear the number of machined workpiece on the screen.

9

## 9.2 User variable (USR VAR)

The functions of user variable include system variable (SYS VAR), user variable (USR VAR), and machine variable (M VAR). You can use the function of system variable to monitor specific variables, and use the functions of user variable and machine variable to enter the names of registers (D512 - D1023) and display the corresponding data on the screen. With the displayed types of registers, you can easily control the corresponding devices by monitoring and changing the setting values of the registers (D512 - D1023).

User Variable		0036ZMC13XZ_1.MC	N1	SFT
No.	Variable name	Value	REG D	
0	Enable Tool Magazine Or Not	0	512	
1	Forcing oil feed	0	513	
2	Lubricant pump ON time	1	514	
3	Lubricant pump OFF time	5	515	
4	X axis direction change	1	516	
5	Y axis direction change	0	517	
6	Z axis direction change	0	518	
7		0	519	
8		0	520	
9		0	521	
10	D522=1 using 4th axis	1	522	
11	A axis direction change	1	523	
12	Unclamping time out	0	530	
13	Clamping time out	8	531	
14		7	532	
Range of Reg D : 512 ~ 1023				
JOG		RPD 100%	JOG 1000	S 100%
Ready				
⬆	USR VAR	SYS VAR	M VAR	▶

Figure 9.2.1

The operation steps for user variable and machine variable are as follows:

- (1) Press **DGN** to enter the DGN screen.
- (2) Press **USR VAR** to enter the variable monitoring screen.
- (3) Press **USR VAR** or **M VAR** to enter the setting screen.
- (4) Press **↑** and **↓** or **PAGE UP** and **PAGE DN** to move the cursor to a specific field.
- (5) Enter the specified register number (D512 - D1023) and press **ENTER** to load the data in the register of the specified number.
- (6) Move the cursor to the value field of the specified register, enter a value, and press **ENTER** to complete the value setting for that register device.
- (7) Press **US DEC**, **HEX**, **S DEC**, or **FLOAT** to select the data format display.
- (8) To delete data, move the cursor to the data field and press **DEL** to delete the data.

### 9.3 MLC

This function displays the current status of each MLC device, so you can monitor and force On or Off each device. You can also check the system status, drive a certain MLC device, or edit the MLC. See Figure 9.3.1 for the MLC screen. MLC-related diagnostic functions include bit status, register status, device monitoring, MLC status switching, and MLC editing. The operation steps for these functions are described in the following sections.

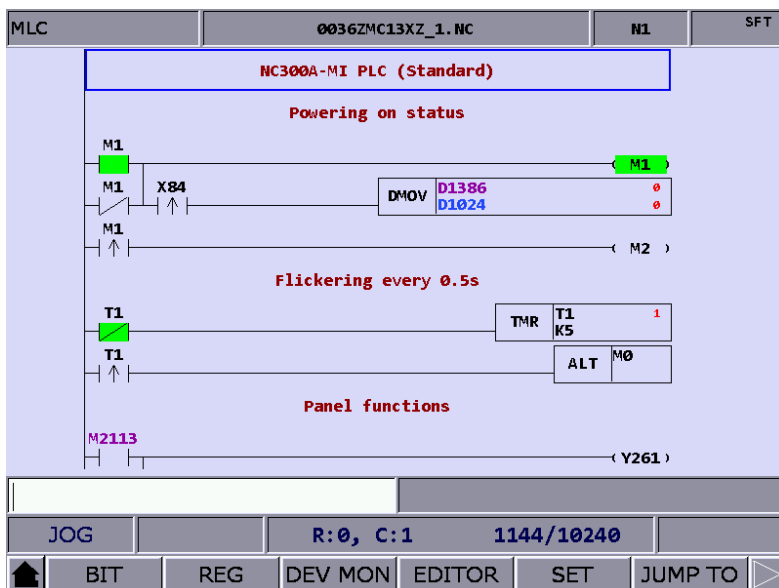

Figure 9.3.1

#### 9.3.1 Bit (BIT)

MLC programs require a number of commands to trigger the devices On / Off. Status of these devices is shown on the MLC Bit Device screen. This function is for displaying the bit type MLC devices, searching the device, and forcing the device to On or Off. The following operation steps take the M devices as an example.

- (1) Press **DGN** to enter the DGN screen.
- (2) Press **MLC** to display the function bar in the second layer.
- (3) Press **BIT** to enter the bit device status display screen.

9

- (4) Press **M** to switch to the status display for M devices as shown in the following figure. Move the cursor to a specific device field or search for the device. by following Step (5).

MLC Bit Device	0036ZMC13XZ_1.NC										N1	SFT
	+0	+1	+2	+3	+4	+5	+6	+7	+8	+9		
M0	0	1	0	0	0	0	0	0	0	0		
M10	1	0	0	0	1	0	0	0	0	0		
M20	0	0	0	0	0	0	0	0	0	0		
M30	0	0	0	0	0	0	0	0	0	0		
M40	0	0	0	0	0	0	0	0	0	0		
M50	0	0	0	0	0	0	0	0	0	0		
M60	0	0	0	0	0	0	0	0	0	0		
M70	0	0	0	0	0	0	0	0	0	0		
M80	0	0	0	0	0	0	0	0	0	0		
M90	0	0	0	0	0	0	0	0	0	0		
M100	0	0	0	0	0	0	0	0	0	0		
M110	0	0	0	0	0	0	0	0	0	0		
M120	0	0	0	0	0	0	0	0	0	0		
M130	0	0	0	0	0	0	0	0	0	0		
M140	0	0	0	0	0	0	0	0	0	0		

JOG		RPD 100%		JOG 1000		S 100%		Ready	
▲	[X]	[Y]	[M]	[A]	[T]	[C]	▶		

Figure 9.3.1.1

- (5) Enter the device name, such as 107, and press **M** to search for the specified device, M107. To change the status of this device, set the system to non-AUTO mode. Refer to Step (6) for the operation steps.
- (6) Specify the device which status is to be changed. Depending on its current status, enter "1" to force it to On and press **ENTER**, or "0" to force it to Off and then press **ENTER**.

### 9.3.2 Register (REG)

Most of the CNC system functions are enabled by MLC programs. MLC devices are divided into bit type and word type. The following operation steps take the word type MLC device and T registers as an example.

- (1) Press **DGN** to enter the DGN screen.
- (2) Press **MLC** to display the function bar in the second layer.
- (3) Press **REG** to enter the register device screen.

MLC Reg Device		0036ZMC13XZ_1.MC		N1	SFT
Dev	Value	Dev	Value		
T0	0	T15	0		
T1	1	T16	0		
T2	0	T17	0		
T3	0	T18	0		
T4	5	T19	0		
T5	0	T20	0		
T6	0	T21	0		
T7	0	T22	0		
T8	0	T23	0		
T9	0	T24	0		
T10	0	T25	0		
T11	0	T26	0		
T12	0	T27	0		
T13	0	T28	0		
T14	0	T29	0		

JOG		RPD 100%	JOG 1000	s 100%	Ready
▲	[ T ]	[ C(16) ]	[ C(32) ]	[ D ]	[ V ] [ Z ] ▶

Figure 9.3.2.1

- (4) Press **T** to enter the register T setting screen.
- (5) Enter the device name, such as 10, and press **T** to search for the device, T10.
- (6) Enter the value in the input field and press **ENTER** to complete the setting.
- (7) Go to the last page of the function bar and press **US DEC, HEX, S DEC, or FLOAT** to select the data format display.

9

### 9.3.3 Device monitoring (DEV MON)

Up to 45 sets of device data can be monitored with this function. The operation steps are as follows.

- (1) Press **DGN** to enter the DGN screen.
- (2) Press **MLC** to display the function bar in the second layer.
- (3) Press **DEV MON** to display the device name input screen as shown in Figure 9.3.3.1.

MLC Dev Monit		0036ZMC13XZ_1.NC		N1	SFT
No.	Dev	Value	Status	Comment	
0					
1					
2					
3					
4					
5					
6					
7					
8					
9					
10					
11					
12					
13					
14					

JOG RPD 100% JOG 1000 S 100% Ready

US DEC HEX S DEC FLOAT CLEAR CLR ALL

Figure 9.3.3.1

- (4) Enter the name of the device to be monitored as shown in Figure 9.3.3.2. You can enter up to 45 device names.

MLC Dev Monit		0036ZMC13XZ_1.NC		N1	SFT
No.	Dev	Value	Status	Comment	
0	X113	####	0	BIT1	
1	Y113	####	0		
2	D1350	0	##		
3					
4					
5					
6					
7					
8					
9					
10					
11					
12					
13					
14					

JOG RPD 100% JOG 1000 S 100%

US DEC HEX S DEC FLOAT CLEAR CLR ALL

Figure 9.3.3.2

**Dev (device):** when the cursor is located in this field, you can enter the name of the device to be monitored.

**Value:** move the cursor to this field to set the data of the device.

**Status:** enter "0" or "1" to set the device status.

In addition, you can switch the data format display according to the requirements by using the functions of US DEC, HEX, S DEC, and FLOAT. The data in Figure 9.3.3.3 are in hexadecimal format and the data in Figure 9.3.3.4 are in floating format.

No.	Dev	Value	Status	Comment
0	X113	####	0	BIT1
1	Y113	####	0	
2	D1350	0x0000	##	
3				
4				
5				
6				
7				
8				
9				
10				
11				
12				
13				
14				

JOG RPD 100% JOG 1000 S 100% Ready

US DEC HEX S DEC FLOAT CLEAR CLR ALL

Figure 9.3.3.3

No.	Dev	Value	Status	Comment
0	X113	####	0	BIT1
1	Y113	####	0	
2	D1350	0.000	##	
3				
4				
5				
6				
7				
8				
9				
10				
11				
12				
13				
14				

JOG RPD 100% JOG 1000 S 100%

US DEC HEX S DEC FLOAT CLEAR CLR ALL

Figure 9.3.3.4



9

### 9.3.4 Line search (JUMP TO)

Use this function to search for a specific line according to the entered line number of the MLC program.

- (1) Press **DGN** to enter the DGN screen.
- (2) Press **MLC** to display the function bar in the second layer.
- (3) Enter a specific line number of the MLC program and press **JUMP TO** to go to the target line.

### 9.3.5 Editor (EDITOR)

Use this function to manage and edit the MLC programs.

You can directly edit the MLC programs on the controller interface with the system set to EDIT mode.

■ Basic MLC commands

Basic MLC commands, including LD, LDI, LDP, LDF, OUT, APP, —, and |, are created with the function of MLC editing, as shown in Figure 9.3.5.1.

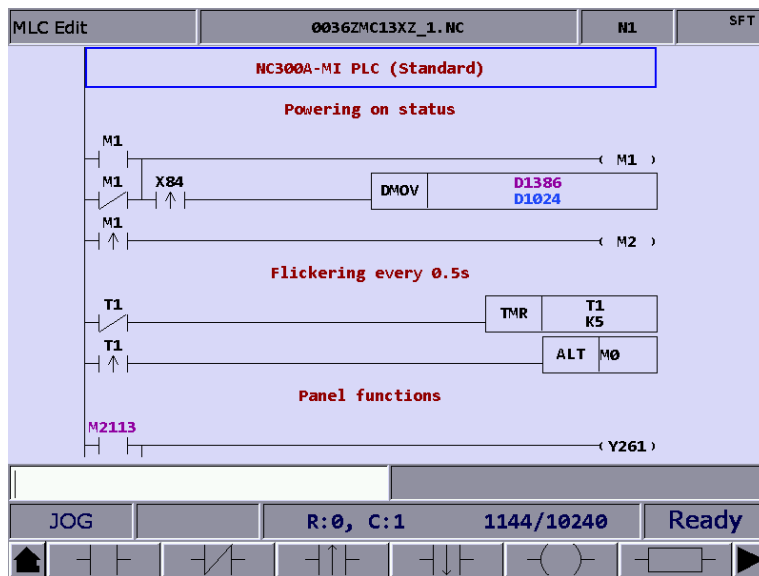

Figure 9.3.5.1

The operation steps for creating command LD are as follows.

- (1) Press **DGN** to enter the DGN screen.
- (2) Press **MLC** to display the function bar in the second layer.
- (3) Press **EDITOR** to enter the MLC Edit screen as shown in Figure 9.3.5.1.
- (4) Press **↑**, **↓**, **←**, and **→** to move the cursor to the field to be edited.
- (5) Enter the device name and press **LD** to complete creating the device.

The above steps are also applicable for creating LDI, LDP, LDF, OUT, and APP commands.

To specify the values for the basic commands, press TABLE to display the MLC table as shown in the following figure.

MLC Table		0036ZMC13XZ_1.NC		ML	SFT
No.	Value	No.	Value		
0	0	15	12600		
1	6020				
2	32				
3	50				
4	79				
5	126				
6	200				
7	320				
8	500				
9	790				
10	1260				
11	2000				
12	3200				
13	5000				
14	7900				

JOG		R:16, C:1	1144/10240	Ready
▲				▶

Figure 9.3.5.2

■ Editing (CUT, COPY, PASTE)

These editing functions are MLC-specific, with which you can delete, cut, or copy a single line of program. Or you can use the SELECT function to delete, cut, or copy a certain section of the MLC program. After completing the editing, use the SAVE function to recompile and save the edited MLC program. The operation steps for editing MLC programs are as follows.





- (1) Press **DGN** to enter the DGN screen.
- (2) Press **MLC** to display the function bar in the second layer.
- (3) Press **EDITOR** to enter the MLC Edit screen as shown in Figure 9.3.5.1.
- (4) Press **↑**, **↓**, **←**, and **→** to move the cursor to the field to be edited.
- (5) Press **▶** repeatedly to display the function bar on the last page in this layer.
- (6) Press the corresponding function key. For example, press **CUT** to perform related edit operations.

When editing MLC programs, press the corresponding function keys according to the editing requirements, including SELECT, DEL, CUT, COPY, PASTE, ADD LN, and DEL LN.

## 9

## ■ SYMBOL

Use this function to search, delete, copy, and paste the MLC devices. MLC program devices are represented with the symbols X, Y, M, A, T, C, D, P, and I. The operation steps are as follows.

- (1) Press **DGN** to enter the DGN screen.
- (2) Press **MLC** to display the function bar in the second layer.
- (3) Press **EDITOR** to enter the MLC Edit screen as shown in Figure 9.3.5.1.
- (4) Press , , , and  to move the cursor to the field to be edited.
- (5) Press  to display the function bar on the third page.
- (6) Press **SYMBOL** to display the corresponding function bar.
- (7) Press the function key, such as **X**, to display the list of corresponding devices.  
and use the functions of delete, copy, or paste as required.

Note: the above steps are applicable to other device symbols.

## ■ Save, import, and export MLC

After editing the MLC program, use the SAVE function to recompile and save the program. Then restart the system to update the MLC program. In addition, use the corresponding function keys (IMPORT / EXPORT) to import or export MLC files.

### 9.3.6 Operation (SET)









The system runs the MLC program right after starting. To manually switch the execution status, use this function to stop the MLC program. This function is for switching the MLC program status to On or Off, which is usually used for testing or checking the MLC devices in the system.

The operation steps are as follows.

- (1) Press **DGN** to enter the DGN screen.
- (2) Press **MLC** to display the function bar in the second layer.
- (3) Press **SET** to switch to the screen of MLC execution status.
- (4) Press **RUN / STP** to force switch the MLC program execution status.

Note: after stopping the MLC program, you can see the status of “MLC Stop” in the system status field.

In addition, you can force the MLC device to On or Off using the corresponding functions.

- The operation steps for forcing the device status to On are as follows.
  - (1) Press **DGN** to enter the DGN screen.
  - (2) Press **MLC** to display the function bar in the second layer.
  - (3) Press **SET** to switch to the screen of MLC execution status.
  - (4) Press , , , and  to move the cursor to a specific device.
  - (5) Press **ON** to switch the device status to On.
  
- The operation steps for forcing the device status to Off are as follows.
  - (1) Press **DGN** to enter the DGN screen.
  - (2) Press **MLC** to display the function bar in the second layer.
  - (3) Press **SET** to switch to the screen of MLC execution status.
  - (4) Press , , , and  to move the cursor to a specific device.
  - (5) Press **OFF** to switch the device status to Off.

# 9

## 9.4 System monitoring (SYS MON)

This **system monitoring** function categorizes the various calculation results of the system and displays them according to their types for your reference.

### 9.4.1 Servo monitoring (SRV MON)

This function displays the servo drive status on the screen of the system, from which you can check the information about the channel port number and servo status of each axis. As shown in Figure 9.4.1.1, both the spindle and Z axis are in the Off status and both X and Y axes are in the On status.

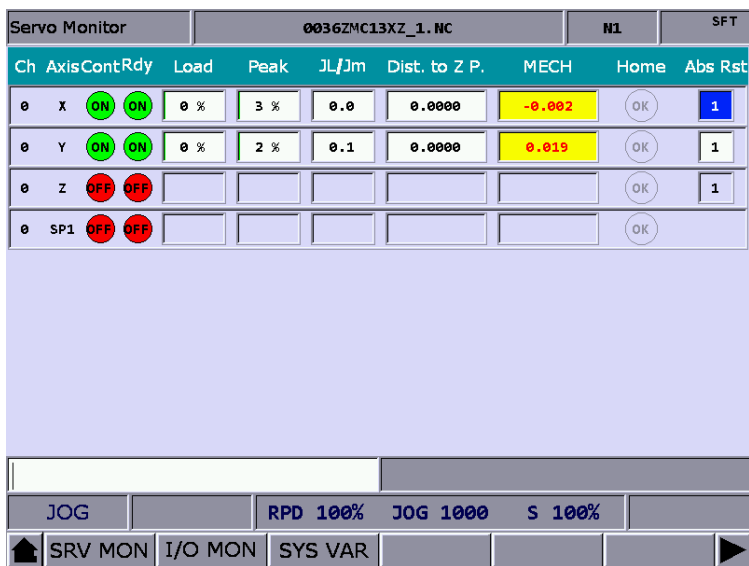

Figure 9.4.1.1

The operation steps are as follows.

- (1) Press **DGN** to enter the DGN screen.
- (2) Press **SYS MON** to switch to the system monitoring screen.
- (3) Press **SRV MON** to display the servo monitoring screen.

### 9.4.2 I/O monitoring (I/O MON)

The NC series system can add the control switches for external devices with the I/O extension modules. You can monitor the status of the I/O extension control board connected to the system on the I/O monitoring screen. The operation steps are as follows.

- (1) Press **DGN** to enter the DGN screen.
- (2) Press **SYS MON** to switch to the system monitoring screen.
- (3) Press **I/O MON** to display the I/O extension module status monitoring screen.

### 9.4.3 Variable monitoring (VAR MON)

- System variables (SYS VAR): VS0 - VS31 and VS100 - VS131. The operation steps are as follows.
  - (1) Press **DGN** to enter the DGN screen.
  - (2) Press **SYS MON** to switch to the system monitoring screen.
  - (3) Press **▶** to display the function bar on the second page.
  - (4) Press **VAR MON** to display the variable monitoring screen.
  - (5) Press **SYS VAR** to display the system variable monitoring screen.
  - (6) Press **PAGE UP** and **PAGE DN** to scroll to the page with the specified variable.
  - (7) You can also enter the full name of a specific system variable and press **ENTER**, or enter the variable number and press **SYS VAR** to search for and display the specified system variable.

System Var		0036ZMC13XZ_1.NC		N1	SFT
Num	Value	Num	Value		
VS0	0	VS16	0		
VS1	0	VS17	0		
VS2	0	VS18	0		
VS3	8	VS19	0		
VS4	0	VS20	0		
VS5	0	VS21	0		
VS6	0	VS22	0		
VS7	0	VS23	0		
VS8	0	VS24	0		
VS9	0	VS25	0		
VS10	0	VS26	0		
VS11	0	VS27	0		
VS12	0	VS28	0		
VS13	0	VS29	0		
VS14	0	VS30	0		
VS15	0	VS31	0		

JOG		RPD 100%	JOG 1000	S 100%	
▲	SYS VAR	CH VAR	AXIS VAR	IF VAR	MLC VAR ▶

Figure 9.4.3.1

- Channel variables (CH VAR): the variable range include VC0 - VC31, VC100 - VC131, and VC200 - VC231. The operation steps are as follows.
  - (1) Press **DGN** to enter the DGN screen.
  - (2) Press **SYS MON** to switch to the system monitoring screen.
  - (3) Press **▶** to display the function bar on the second page.
  - (4) Press **VAR MON** to display the variable monitoring screen.
  - (5) Press **CH VAR** to display the channel variable screen.
  - (6) Press **PAGE UP** and **PAGE DN** to scroll to the page with the specified variable.
  - (7) You can also enter the full name of a specific channel variable and press **ENTER**, or enter the variable number and press **CH VAR** to search for and display the specified channel variable.

## 9

- Axis variables (AXIS VAR): variable range includes VA0 - VA31, VA100 - VA131, and VA200 - VA231.

The operation steps are as follows.

- (1) Press **DGN** to enter the DGN screen.
- (2) Press **SYS MON** to switch to the system monitoring screen.
- (3) Press **▶** to display the function bar on the second page.
- (4) Press **VAR MON** to display the variable monitoring screen.
- (5) Press **AXIS VAR** to display the axis variable screen.
- (6) Press **PAGE UP** and **PAGE DN** to scroll to the page with the specified variable.
- (7) You can also enter the full name of a specific axis variable and press **ENTER**, or enter the variable number and press **AXIS VAR** to search for and display the specified axis variable.

- Interface variables (IF VAR): variable range includes VH0 - VH31, VH200 - VH231, VH400 - VH431, and VH800 - VH863.

The operation steps are as follows.

- (1) Press **DGN** to enter the DGN screen.
- (2) Press **SYS MON** to switch to the system monitoring screen.
- (3) Press **▶** to display the function bar on the second page.
- (4) Press **VAR MON** to display the variable monitoring screen.
- (5) Press **IF VAR** to display the interface variable monitoring screen.
- (6) Press **PAGE UP** and **PAGE DN** to scroll to the page with the specified variable.
- (7) You can also enter the full name of a specific axis variable and press **ENTER**, or enter the variable number and press **IF VAR** to search for and display the specified interface variable.

- MLC variables (MLC VAR): variable range include VM0 - VM49. The operation steps are as follows.

- (1) Press **DGN** to enter the DGN screen.
- (2) Press **SYS MON** to switch to the system monitoring screen.
- (3) Press **▶** to display the function bar on the second page.
- (4) Press **VAR MON** to display the variable monitoring screen.
- (5) Press **MLC VAR** to display the MLC variable monitoring screen.
- (6) Press **PAGE UP** and **PAGE DN** to scroll to the page with the specified variable.
- (7) You can also enter the full name of a specific MLC variable and press **ENTER**, or enter the variable number and press **MLC VAR** to search for and display the specified MLC variable.

## 9.5 Password setting (PWD)

In order to effectively control the operation security of the system functions, you can use this function to assign different levels of authorization for the system (system maintenance), machine (mechanical devices), and user (operation).

This prevents unauthorized users from changing the system settings and thus affecting the system operation.

### 9.5.1 System security (S SCP)

This function includes security lock (LOCK), security unlock (UNLOCK), and system check (SYS CHECK). The password must be four characters containing at least one letter and one number (no special characters). The operation steps for locking and unlocking the system security are as follows.

- (1) Press **DGN** to enter the DGN screen.
- (2) Press **PWD** to switch to the function bar of password setting.
- (3) Press **S SCP** to display the corresponding function bar.
- (4) When the system security is in the unlocked status, press **LOCK** to immediately lock all system-related functions.
- (5) When the system security is in the locked status, press **UNLOCK**, and a dialog box appears for you to enter the valid password.
- (6) After entering the password, press **ENTER** to unlock the system.

The operation steps for system check are as follows.

- (1) Press **DGN** to enter the DGN screen.
- (2) Press **PWD** to switch to the function bar of password setting.
- (3) Press **S SCP** to display the corresponding function bar.
- (4) When the system is in unlocked status, press **SYS CHECK** to check the status of the items.  
If the check box for an item is selected, it means that item is in error.



9

9.5.2 Machine security (M SCP)

This function includes password change (PWG CHG), security lock / security unlock (LOCK / UNLOCK), and user reset (RST U1 and RST U2).

The password must be four characters containing at least one letter and one number (no special characters). The operation steps for changing the machine security are as follows.

- (1) Press **DGN** to enter the DGN screen.
- (2) Press **PWD** to switch to the function bar of password setting.
- (3) Press **M SCP** to switch to the function bar of machine security.
- (4) Press **PWD CHG** and a dialog box appears as shown in Figure 9.5.2.1. Enter the old password, new password, and retype the new password for confirmation.
- (5) Press **ENTER** to complete changing the password.

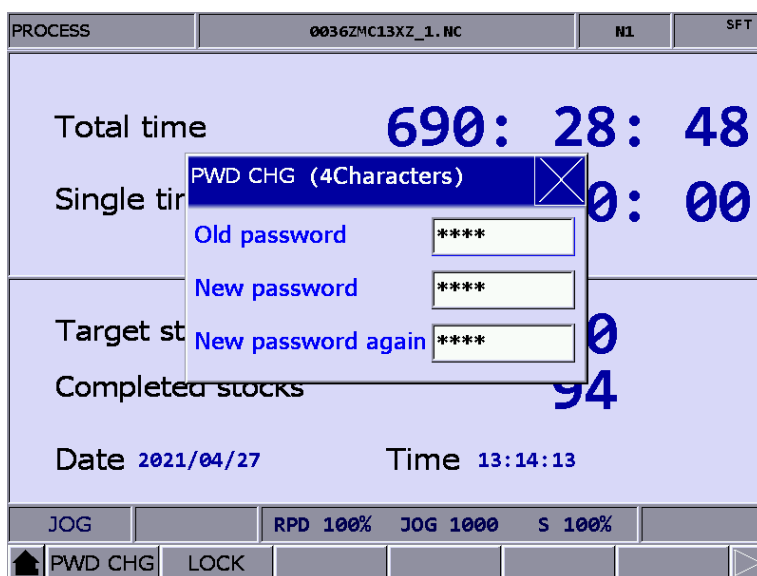

Figure 9.5.2.1

The operation steps for unlocking the machine security are as follows.

- (1) Press **DGN** to enter the DGN screen.
- (2) Press **PWD** to switch to the function bar of password setting.
- (3) Press **M SCP** to switch to the function bar of machine security.
- (4) When the machine security is in the locked status, press **UNLOCK** and a dialog box appears for you to enter the valid password.
- (5) Enter the valid password and press **ENTER** to unlock the machine security.

Note: The default password for machine security is 0000 which is not assigned to any authorization level, meaning that users of any level can access the machine-related functions. You need to change the default password of 0000 to enable the machine security, and only users with the authorization can access the machine-related functions.

The operation steps for locking the machine security are as follows.

- (1) Press **DGN** to enter the DGN screen.
- (2) Press **PWD** to switch to the function bar of password setting.
- (3) Press **M SCP** to switch to the function bar of machine security.
- (4) When the machine security is in the unlocked status, press **LOCK** to immediately lock all machine-related functions.

The function of user reset allows the equipment supplier to reset the user’s password. When customers forgot their user passwords, they can ask the equipment vendor to reset the password to the factory default password. This function is only available when the password is changed from the default.

The operation steps are as follows.

- (1) Press **DGN** to enter the DGN screen.
- (2) Press **PWD** to switch to the function bar of password setting.
- (3) Press **M SCP** to switch to the function bar of machine security.
- (4) Press **RST U1** or **RST U2** to reset the user’s password.

Function enabling (FUN ENA) allows the equipment supplier to enable or disable the group functions. Once the selected group function check box is cleared, the group function is disabled after restarting. The operation steps are as follows.





- (1) Press **DGN** to enter the DGN screen.
- (2) Press **PWD** to switch to the function bar of password setting.
- (3) Press **M SCP** to switch to the function bar of machine security.
- (4) Press **FUN ENA** to enter the setting screen for enabling or disabling the group functions.
- (5) Press **↑** and **↓** to move the cursor to the check box of the group function to be cleared and press **ENTER** to clear the check box. Then press **OK** and restart the system for the changes to take effect.
- (6) Continued from Step (5), to maintain the original settings, press **CANCEL** to exit the screen and discard the previous settings.
- (7) To restore to the system default setting, press **DEFAULT**.



Figure 9.5.2.2

## 9

The function of restoring to default (DEFAULT) allows users to restore the system with the system backup file when the system is in error or the system data is seriously damaged. In the Default screen, if the check box is selected, it means the data of that item is damaged. You can use this function to restore the data of that item. This function is available only when you have the proper authorization. The operation steps are as follows.

- (1) Press **DGN** to enter the DGN screen.
- (2) Press **PWD** to switch to the function bar of password setting.
- (3) Press **M SCP** to switch to the function bar of machine security.
- (4) Press **DEFAULT** to enter the corresponding screen and press , ,  and  to move the cursor. Press **ENTER** to select the item to be restored.
- (5) Clear the check box: move the cursor to the selected item and press **ENTER** to clear the check box.
- (6) Press **OK** to restore the system.

### 9.5.3 User security (User SCP)

This function includes U1 SCP and U2 SCP. The functions of user security include password change (PWD CHG), security lock (LOCK), and security unlock (UNLOCK). The password must be four characters containing at least one letter and one number (no special characters). Take U1 SCP for example, the operation steps for changing the user password are as follows.

- (1) Press **DGN** to enter the DGN screen.
- (2) Press **PWD** to switch to the function bar of password setting.
- (3) When U1 SCP is locked, press **U1 SCP** and a dialog box appears for you to enter the password for U1 SCP.
- (4) Enter the valid password for U1 SCP, then press **ENTER**, and U1 SCP is unlocked and the corresponding function bar is displayed.
- (5) Press **PWD CHG** and a dialog box appears. Enter the old password, new password, and retype the new password for confirmation.
- (6) Press **ENTER** to complete changing the password.

The operation steps for unlocking the user security are as follows.

- (1) Press **DGN** to enter the DGN screen.
- (2) Press **PWD** to switch to the function bar of password setting.
- (3) When U1 SCP is locked, press **U1 SCP** and a dialog box appears for you to enter the password for U1 SCP.
- (4) Enter the valid password for U1 SCP, then press **ENTER**, and U1 SCP is unlocked and the corresponding function bar is displayed.

The operation steps for locking the user security are as follows.

- (1) Press **DGN** to enter the DGN screen.
- (2) Press **PWD** to switch to the function bar of password setting.
- (3) When U1 SCP is unlocked, press **U1 SCP** and a dialog box appears for you to enter the password for U1 SCP.
- (4) Press **LOCK** to lock U1 SCP.

Note: the function of user security is the same as that of machine security. The default password for user security is 0000 which is not assigned to any authorization level. You need to change the default password of 0000 to enable the user security.

9

### 9.5.4 Expiration time (EXPIRE)

For specific situations that require a time limit on usage, you can set the operation time for the controller by security authorization. After the time limit is set, the available duration (hours / days) is automatically controlled by the system. When this function is enabled, you can only remove or reset the time limit with the proper authorization. When the time limit is not set or disabled, no **expiration date** is displayed in the Deadline field on the screen, as shown in Figure 9.5.4.1. Once you set the **time limit** and do not disable it, the **expiration date** is displayed in the Deadline field, as shown in Figure 9.5.4.2.



Figure 9.5.4.1

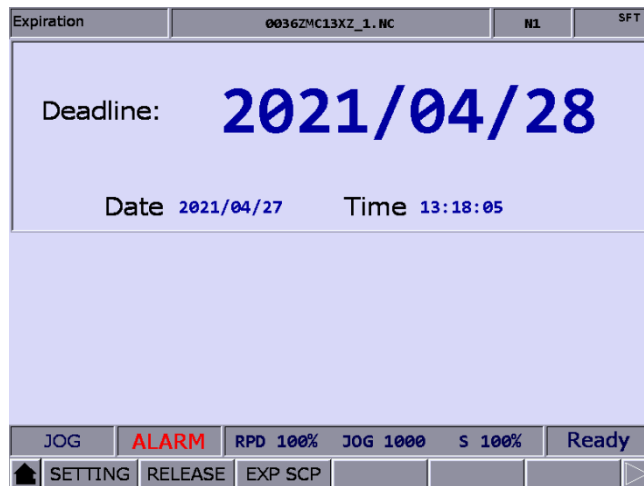

Figure 9.5.4.2

You can see the controller's operation expiration date and time on this screen. When the duration is up, the system will be locked, meaning that any execution of G-code program (in both AUTO and MDI modes) is prohibited. The execution will not resume until the time limit setting is disabled or extended. If the time limit expires, contact the distributor or equipment supplier for entering the valid password to remove the time limit.

You can set the time limit only when the function is not enabled. The operation steps for setting the time limit are as follows:

- (1) Press **DGN** to enter the DGN screen.
- (2) Press **PWD** to switch to the function bar of password setting.
- (3) Press **EXPIRE** to display the expiration information.
- (4) Press **SETTING** to display the setting screen of time limit.
- (5) Enter a valid password to set the time limit for the controller's operating duration.

The operation steps for removing the time limit are as follows (contact the distributor or equipment supplier for services).

- (1) Press **DGN** to enter the DGN screen.
- (2) Press **PWD** to switch to the function bar of password setting.
- (3) Press **EXPIRE** to display the expiration information.
- (4) Press **RELEASE** and a dialog box appears for you to enter the activation code as shown in Figure 9.5.4.3.

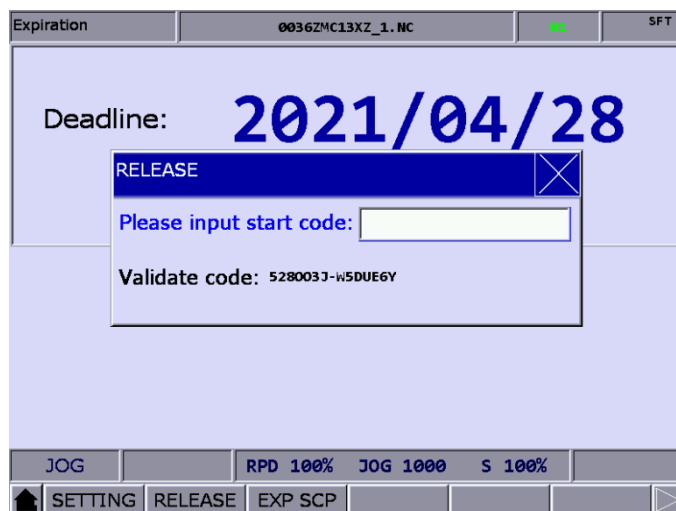

Figure 9.5.4.3

- (5) After being authorized legally, enter the activation code, press **ENTER** to reconnect power to the NC system to remove the time limit.

Note: after the time limit is removed, no expiration date is displayed in the **Deadline** field as shown in Figure 9.5.4.1, which means no time limit is set for the system.

## 9

The proper authorization is required to lock or unlock the **EXP SCP** function. When the function is locked, enter the valid security password to unlock it. When the function is unlocked, you can use all the functions for the time limit setting. The functions include password change (PWD CHG), security lock (LOCK), and security unlock (UNLOCK). The password must be four characters containing at least one letter and one number (no special characters). The operation steps are as follows.

The operation steps for changing the password for EXP SCP are as follows.

- (1) Press **DGN** to enter the DGN screen.
- (2) Press **PWD** to switch to the function bar of password setting.
- (3) Press **EXPIRE** to display the expiration information.
- (4) When EXP SCP is locked, press **EXP SCP** and a dialog box appears for you to enter the password for EXP SCP.
- (5) Enter the valid password, press **ENTER**, and EXP SCP is unlocked and the corresponding function bar appears.
- (6) Press **PWD CHG** and a dialog box appears. Enter the old password, new password, and retype the new password for confirmation.
- (7) Press **ENTER** to complete changing the password for EXP SCP.

The operation steps for unlocking the expiration security are as follows.

- (1) Press **DGN** to enter the DGN screen.
- (2) Press **PWD** to switch to the function bar of password setting.
- (3) Press **EXPIRE** to display the expiration information.
- (4) When EXP SCP is locked, press **EXP SCP** and a dialog box appears for you to enter the password for EXP SCP.
- (5) Enter the valid password, press **ENTER**, and EXP SCP is unlocked and the corresponding function bar appears.

The operation steps for locking the expiration security are as follows.

- (1) Press **DGN** to enter the DGN screen.
- (2) Press **PWD** to switch to the function bar of password setting.
- (3) Press **EXPIRE** to display the expiration information.
- (4) When EXP SCP is unlocked, press **EXP SCP** to display the corresponding function bar.
- (5) Press **LOCK** to lock EXP SCP.





9

### 9.7 Gain tuning (TUNING)

The auto tuning function enables the NC system and servo drive to provide optimized motion control for meeting different machine characteristics. The NC series controller reads the initial servo parameters and calibrates the motion control with the gain tuning function. The results of gain tuning are returned to the servo drive, so the control parameters of the controller and drive are consistent. This facilitates the gain tuning procedure and maintains high-precision control of the system. The Servo Tuning screen is as shown in the following figure and the operation steps for each subordinate function are as follows.

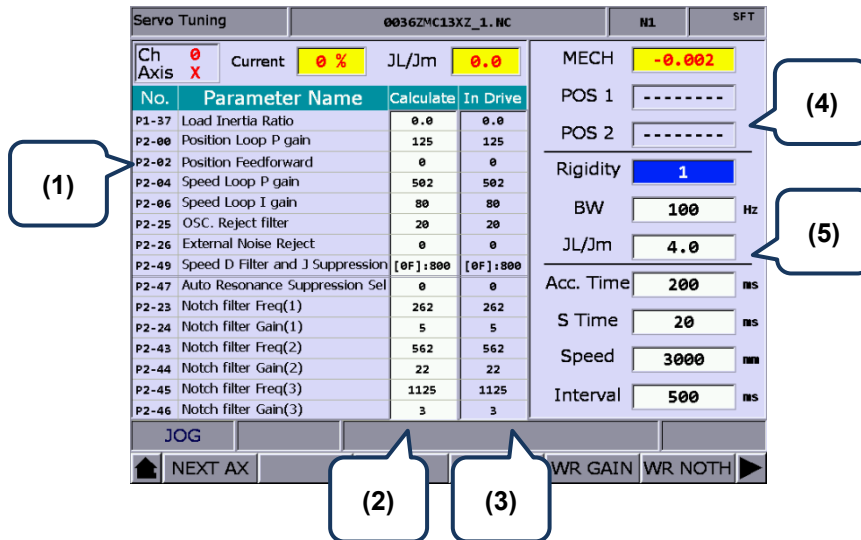

- (1) Servo parameter: number and name of servo parameters
- (2) Results after gain tuning: displays the calculation results of auto tuning
- (3) System settings: displays the current servo settings
- (4) Position setting: Position 1 / Position 2
- (5) Tuning conditions

■ **Next axis (NEXT AX):** for switching to another axis for gain tuning setting. You need to perform auto tuning for each axis separately, so after completing the setting of one axis, use this function to switch to another axis and continue auto tuning. The operation steps are as follows.

- (1) Press **DGN** to enter the DGN screen.
- (2) Press **▶** to display the function bar on the next page.
- (3) Press **TUNING** to enter the auto tuning setting screen.
- (4) If you need to set the gain parameters for other axes, press **NEXT AX** to switch to the specified axis.

■ **Read servo parameters (READ):** Accesses the parameter values from the servo and writes them in the Calculate fields. The operation steps are as follows.

- (1) Press **DGN** to enter the DGN screen.
- (2) Press **▶** to display the function bar on the next page.
- (3) Press **TUNING** to enter the auto tuning setting screen.
- (4) Press **READ** to read the servo parameters back to the controller.

- **RUN, JOG←, JOG→, POS1, POS2:** These functions are for setting the operation of auto tuning. Use these functions to enable auto tuning, and set and operate the positioning direction. The operation steps for the continuous operation of a single axis are as follows.
  - (1) Press **DGN** to enter the DGN screen.
  - (2) Press **▶** to display the function bar on the next page.
  - (3) Press **TUNING** to enter the auto tuning setting screen.
  - (4) Press **▶** to display the function bar on the next page.
  - (5) Press **JOG←** to move to the left positioning point.
  - (6) Press **POS1** to set the left positioning point.
  - (7) Press **JOG→** to move to the right positioning point.
  - (8) Press **POS2** to set the right positioning point. The movement is now limited to between Position 1 and Position 2.
  - (9) Press **RUN** to start auto tuning.
  - (10) During auto tuning, press **STOP** to complete tuning. The system automatically calculates the best gain value.
  
- **Gain calculation (COMPUTE):** To change the parameter values of rigidity, bandwidth, or inertia to accommodate the machine characteristics, you can use this function to calculate and generate the results of gain tuning. The operation steps for calculating the gain value of a single axis are as follows.
  - (1) Press **DGN** to enter the DGN screen.
  - (2) Press **▶** to display the function bar on the next page.
  - (3) Press **TUNING** to enter the auto tuning setting screen.
  - (4) Press **↑** and **↓** to move the cursor to the fields of Rigidity, BW, and JL/Jm to set the parameters.
  - (5) Press **COMPUTE** to calculate the tuning results.
  
- **Gain value writing (WR GAIN), resonance value writing (WR NOTH):** The system automatically calculates the gain values after auto tuning is finished and the motion stops. If the values after auto tuning meet the expectation, you can use these functions to write the new parameter values to the servo. The operation steps are as follows.
  - (1) Press **DGN** to enter the DGN screen.
  - (2) Press **▶** to display the function bar on the next page.
  - (3) Press **TUNING** to enter the auto tuning setting screen.
  - (4) After tuning, the results are automatically calculated.
  - (5) Press **WR GAIN** to write the corresponding gain parameters to the servo. Press **WR NOTH** to write the parameter values for resonance suppression to the servo.

Note:

1. You have to write the results of auto tuning to the servo for the values to take effect.
2. After writing the gain values and resonance values, the servo parameters are updated and the previous settings cannot be restored. Thus, double check before writing the values.

## 9

- **Calibration for tapping (TAP RIV):** In tapping applications, calibrate the machine and servo with this function.

If you use Delta servo products for the spindle, the operation steps for TAP SET(1) are as follows.

- (1) Press **DGN** to enter the DGN screen.
- (2) Press **▶** to display the function bar on the next page.
- (3) Press **TUNING** to enter the auto tuning setting screen.
- (4) Complete the gain tuning for the servo axes X, Y, and Z, and the spindle.
- (5) Press **▶** to switch to the function bar on the last page.
- (6) Press **TAP RIV** to switch to the corresponding screen.
- (7) Press **TAP SET (1)** and a confirmation window appears. Enter “Y” and press **ENTER** to complete calibrating the machine for tapping applications.

If you use Delta AC inverters or third-party servo for the spindle, the operation steps for TAP SET (2) are as follows.

- (1) Press **DGN** to enter the DGN screen.
- (2) Press **▶** to display the function bar on the next page.
- (3) Press **TUNING** to enter the auto tuning setting screen.
- (4) Complete the gain tuning for the servo axes X, Y, and Z, and the spindle.
- (5) Press **▶** to switch to the function bar on the last page.
- (6) Press **TAP RIV** to switch to the corresponding screen.
- (7) Next, press **TAP SET (2)** and a confirmation window appears. Enter “Y” and press **ENTER**. Next, the spindle control ratio gain input window will appear; enter the correct value and then press **ENTER**, and the system will adjust the tap setting of the machine according to this value.

- **Servo parameters (SERVO):** For displaying and setting servo parameters in the Servo Tuning screen. The operation steps are as follows.

- (1) Press **DGN** to enter the DGN screen.
- (2) Press **▶** to display the function bar on the next page.
- (3) Press **TUNING** to enter the auto tuning setting screen.
- (4) Press **▶** repeatedly to switch to the function bar on the last page.
- (5) Press **SRV MON** to display the servo parameter screen.
- (6) Move the cursor to the field of the parameter to be edited, enter the value, and press **ENTER** to complete the setting for that parameter field.

### 9.8 Import (IMPORT)

You can use this function to import the backup parameters to the NC system with security authorized. The operation steps for importing parameters are as follows:

- (1) Press **DGN** to enter the DGN screen.
- (2) Press **▶** to display the function bar on the next page.
- (3) Press **IMPORT** to display the file manager (FILE) window as shown in Figure 9.8.1. Press **↑** and **↓**, select the directory for importing, and press **ENTER** to read the files in the folder.

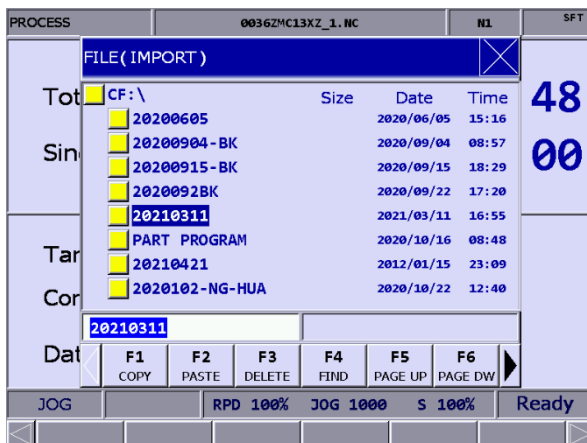

Figure 9.8.1

- (4) After entering the parameter selection screen, press **↑**, **↓**, **←** and **→** to move the cursor to the system parameter to be imported, press **ENTER** to select it or cancel selection.
- (5) To select all the check boxes, press **SEL ALL**. To clear all the selected check boxes, press **CLR ALL**.

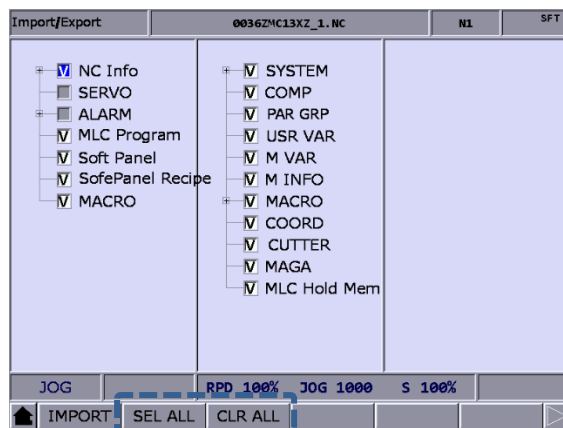

Figure 9.8.2

- (6) Press **IMPORT** and a dialog box for confirmation appears. Enter “Y” and press **ENTER** to import the data of the files to the system. Then, a progress bar of the importing process is displayed. Cycle power to the system after completing importing the files.

9

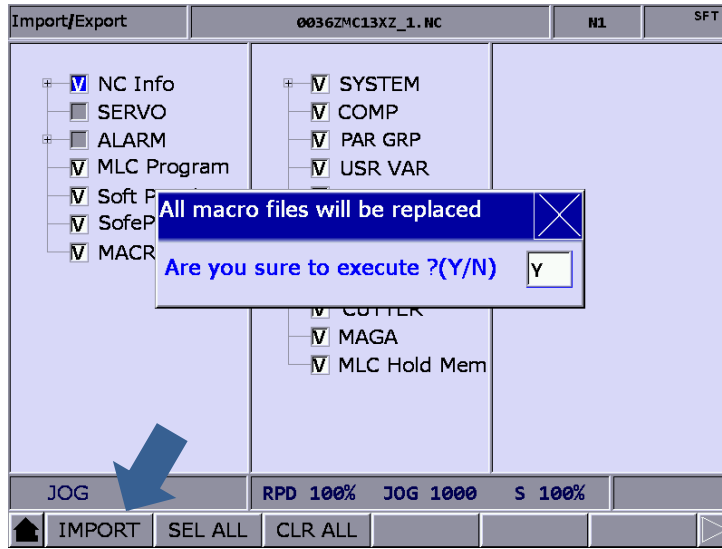

Figure 9.8.3

### 9.9 Export (EXPORT)

Use this function to back up the parameters of the system. The exported files are divided into three types: parameter files, MLC, and software panel. You have to access the security authorization to use this function.

Type	Filename	Description
Parameter files	PAR.ncp	NC information, servo parameters, and alarms
MLC	MLC.gmc	MLC programs
MLC	MLC.lad	Image codes for MLC Ladder
MLC	MLC.lcm	Remarks for MLC Ladder
Software panel	HMI.cin	Screen information and element properties for software panel
Software panel	HMI.img	Graphic files for software panel
Software panel	HMI.sci	Project files for software panel

The operation steps for exporting parameters are as follows:

- (1) Press **DGN** to enter the DGN screen.
- (2) Press **▶** to display the function bar on the next page.
- (3) Press **EXPORT** to enter the parameter export selection screen.
- (4) After entering the parameter selection screen, press **↑**, **↓**, **←** and **→** to move the cursor to the system parameter to be exported, press **ENTER** to select it or cancel selection. To select all the check boxes, press **SEL ALL**. To clear all the selected check boxes, press **CLR ALL**.

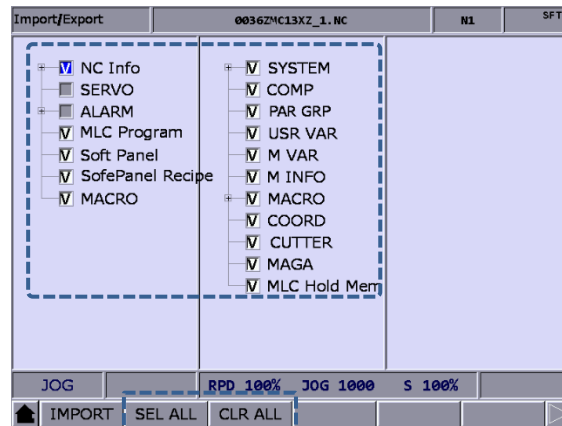

Figure 9.9.1

9

- (5) Press **EXPORT** and the file manager (FILE) window appears as shown in Figure 9.9.2.  
Press **↑** and **↓** to select the directory for saving the exported files, or directly enter the folder name and press **ENTER** to save the exported files to the specified folder.

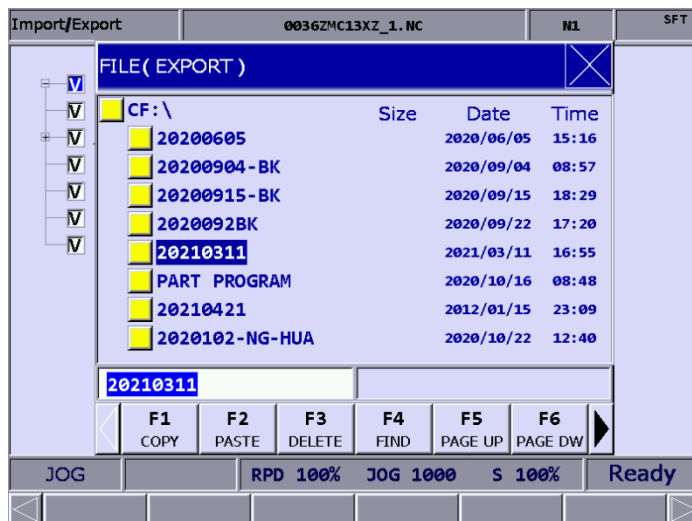

Figure 9.9.2

- (6) Then, the screen displays a progress bar showing the exporting process until the exporting is finished.
- (7) If you want to save the exported file to a new created folder, name the folder, then press **FOLDER** to save the exported file in the folder, as shown in Figure 9.9.2.
- (8) If you save the exported file to a folder where an exported file already exists, a confirmation window appears. Enter “Y” and press **ENTER** to replace the existing file with the newly exported file.

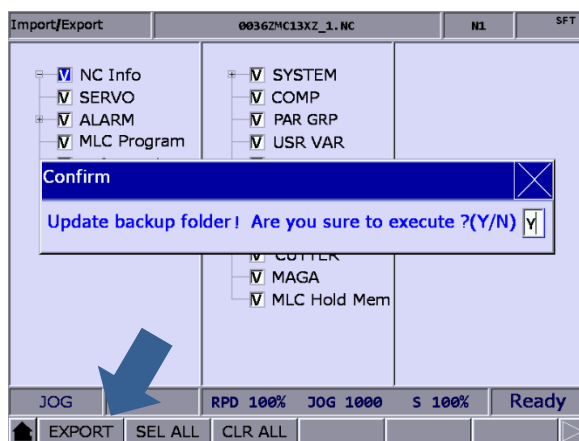

Figure 9.9.3

## 9.10 Multi-language (TEXT WR)

The default display languages for the group screens and corresponding function bars are Traditional Chinese, Simplified Chinese, and English. If there is a need for other languages, use this function to switch the interface to other languages. Contact the distributors or equipment suppliers for related information.

## 9.11 LOGO (LOGO WR)

Use **LOGO WR** to set the startup screen of the NC system with user-defined pictures for displaying the trademark or for other purposes. This function is available only when you have the proper authorization. The operation steps are as follows.

- (1) Press **DGN** to enter the DGN screen.
- (2) Press **▶** repeatedly to display the function bar on the 2<sup>nd</sup> page.
- (3) Insert the USB disk with the correct system startup screen file (SYSLOGO.bin) in it to the controller.
- (4) Press **LOGO WR** and a dialog box appears for confirmation.
- (5) Enter “Y”, press OK, and the system automatically reads and loads the startup screen file from the USB disk.
- (6) After the LOGO image file is updated, restart the system to display the updated startup screen.



(This page is intentionally left blank.)

# 9

# Alarm (ALM) Group

# 10

The ALM group displays the alarm messages issued by the system in real time.



10.1 Alarm (ALARM) .....	10-2
10.2 Alarm history (HISTORY).....	10-3

If an alarm occurs due to execution error or incorrect command format, the Alarm screen is automatically displayed.

This group shows the alarm messages issued by the system in real time for you to troubleshoot the errors according to the displayed alarm information. In addition to displaying the current alarms, the ALM group also records the previous alarms.

Note: **Function names** in a box (such as **POS**) mean the keys on machine operation panel A; bold **function names** (such as **CLR ALL**) mean the function keys of F1 - F6.

### 10.1 Alarm (ALARM)

When an alarm occurs, troubleshoot the issue first, and then press **RESET** to clear the alarm and set the system to the initial status. The alarm display screen is as shown in the following figure and the sections with indicators show information about the alarms.

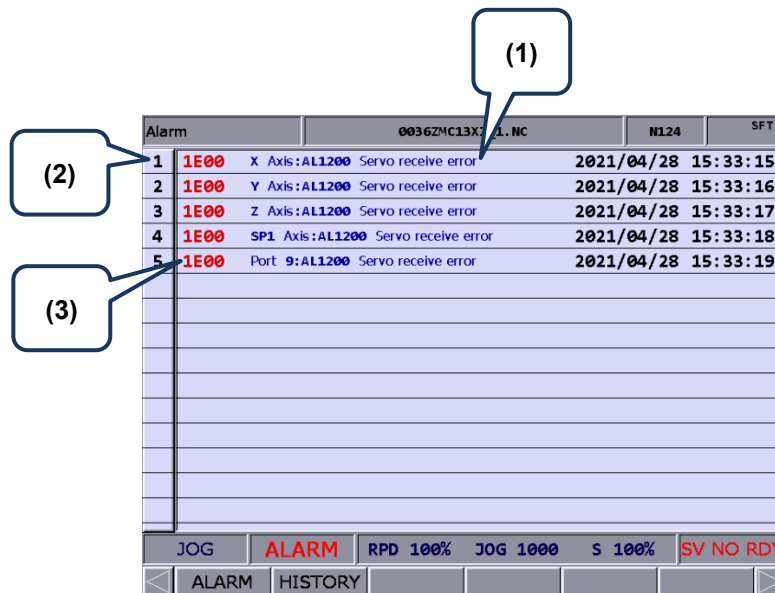

Figure 10.1.1

- (1) Alarm message
- (2) Sequence of alarm occurrence
- (3) Alarm code

The operation steps for displaying and clearing the alarm messages are as follows.

- (1) Press **ALM** to enter the ALM screen.
- (2) Press **ALARM** to enter the alarm message screen.
- (3) Press **RESET** to clear the alarm messages shown on the screen.

## 10.2 Alarm history (HISTORY)

This function records all the issued alarm messages and history information. In the History screen, you can access the error history during system execution as well as troubleshoot and analyze the errors according to the occurrence time and types of alarms. The alarm history records the occurrence time and names of the alarms. It can record up to 512 sets of data. In addition to displaying the alarm information, you can also delete the alarm history with this function.

History	0036ZMC13XZ_1.NC	N1	SFT
1	<b>B020</b> EMERGENCY STOP	2021/04/27	14:51:30
2	<b>1213</b> DMCNET INIT ERROR	2021/04/27	14:51:19
3	<b>B020</b> EMERGENCY STOP	2021/04/27	14:50:56
4	<b>1E00</b> Port 9:AL1200 Servo receive error	2021/04/27	14:50:56
5	<b>1E00</b> SP1 Axis:AL1200 Servo receive error	2021/04/27	14:50:55
6	<b>1E00</b> Z Axis:AL1200 Servo receive error	2021/04/27	14:50:54
7	<b>1E00</b> Y Axis:AL1200 Servo receive error	2021/04/27	14:50:53
8	<b>1E00</b> X Axis:AL1200 Servo receive error	2021/04/27	14:50:52
9	<b>B020</b> EMERGENCY STOP	2021/04/27	14:50:48
10	<b>B020</b> EMERGENCY STOP	2021/04/27	14:50:46
11	<b>3208</b> MACHINE WILL BE LOCKED( 1 Day)	2021/04/27	13:59:16
12	<b>1E00</b> Z Axis:0x0303	2021/04/27	13:47:36
13	<b>1E00</b> SP1 Axis:AL2400 Servo parameter read error	2021/04/27	13:47:24
14	<b>1E00</b> Z Axis:AL2400 Servo parameter read error	2021/04/27	13:47:24
15	<b>1E00</b> SP1 Axis:AL1200 Servo receive error	2021/04/27	13:47:24

JOG **ALARM** RPD 100% JOG 1000 S 100% SV NO RDY

CLR ALL

Figure 10.2.1

The operation steps for clearing all the alarm history are as follows.

- (1) Press **ALM** to enter the ALM screen.
- (2) Press **HISTORY** to enter the alarm history screen.
- (3) Press **CLR ALL** and a confirmation window appears.
- (4) Press **Y** and then **ENTER** to clear all the alarm history.

(This page is intentionally left blank.)

# 10

## Graph (GRA) Group

---

The GRA group displays the real-time motion trajectory when the program is executing or checks the machining program when the program is not executing.



11.1	Trajectory display.....	11-3
11.2	Program simulation .....	11-4

The GRA group provides two functions, trajectory display and program simulation (preview).  
 Trajectory display: displays the current processing trajectory during processing.  
 Program simulation: for checking whether the program format and path are correct before processing.

11

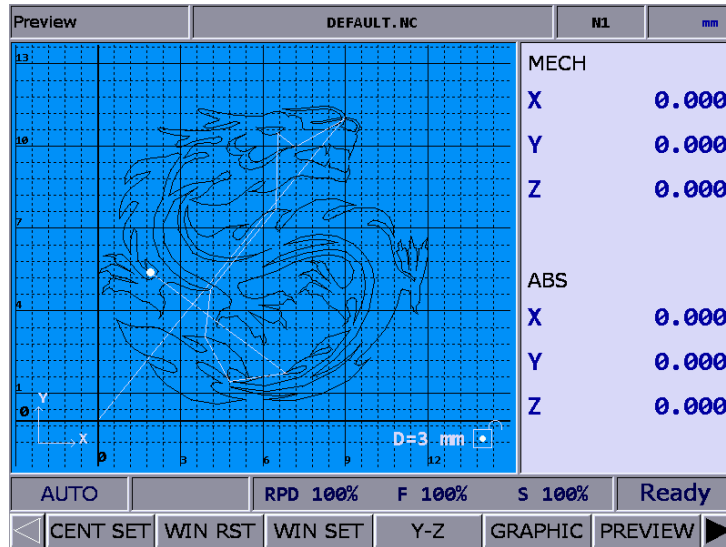

Note: **Function names** in a box (such as POS) mean the keys on machine operation panel A;  
 bold **function names** (such as CLR ALL) mean the function keys of F1 - F6.

## 11.1 Trajectory display

When a machining program is executing, switch the system to GRA mode, and the system automatically draws the motion trajectory of the current program on the screen, with which you can check if the actual machining path is correct.

Function descriptions of the keys are as follows.

- (1) **GRA**: enters the GRA screen.
- (2) **CENT SET (center setting)**: displays the current motion trajectory in the center of the display area.
- (3) **WIN RST (window reset)**: scales the graph to a moderate size and locate it in the middle of the screen.
- (4) **WIN SET (window adjustment)**: press **UP**, **DOWN**, **LEFT**, **RIGHT**, **ZM IN**, and **ZM OUT** in the WIN SET screen to adjust the display of the path graph.
- (5) **Clear**: clears the content of the tool path display area.



## 11.2 Program simulation

This function draws the complete path of the G-code program for you to check if the program format is correct before the machining starts. This function can be further divided into GRAPHIC (graphic preview) and PREVIEW (machining preview).

Function descriptions of the keys are as follows.

- (1) Press the **GRA** button to enter the GRA screen.
- (2) **CENT SET (center setting)**: displays the current motion trajectory in the center of the display area.
- (3) **WIN RST (window reset)**: scales the graph to a moderate size and locate it in the middle of the screen.
- (4) **WIN SET (window adjustment)**: press **UP**, **DOWN**, **LEFT**, **RIGHT**, **ZM IN**, and **ZM OUT** in the WIN SET screen to adjust the display of the path graph.
- (5) **PV (Step Preview)**: draws the path of one single block when this key is pressed.
- (6) **GRAPHIC**: checks the program format without referring to the software limit and draws the complete path according to the program.
- (7) **PREVIEW**: checks the program format by referring to the software limit. The settings of the coordinate system and the tool compensation should match the actual application so the complete path can be correctly drawn.
- (8) **Clear**: clears the content of the tool path display area.

Pay attention to the following when using the functions of GRA:

1. When the Preview function is enabled, machining execution is prohibited.
2. When the Preview function is enabled, switching the system mode will force close this function.
3. If you cancel the preview during previewing, you need to start from the initial block if desiring to preview again.
4. Graphs drawn by the function of GRAPHIC or PREVIEW may exceed the display area because of the workpiece coordinate settings. If so, press **GRAPHIC** or **PREVIEW** again, and the system automatically displays a moderate preview graph in the center of the display area.
5. Use Pr14003 to set the default display of the graph.

# Parameter (PAR) Group

# 12

The PAR group gathers the control and setting of various functions of the NC system in this group. This chapter introduces functions and settings for all of the parameters.



12.1	Machining parameter (PROCESS) .....	12-4
12.1.1	Machining parameter descriptions .....	12-4
12.2	Operating parameter (OPERATE) .....	12-7
12.2.1	Operating parameter descriptions .....	12-7
12.3	Tool magazine parameter (MAGA) .....	12-22
12.3.1	Tool magazine parameter descriptions .....	12-22
12.4	Spindle parameter (SPINDLE) .....	12-24
12.4.1	Spindle parameter descriptions .....	12-24
12.5	Machine parameter (MACHINE) .....	12-30
12.5.1	Machine parameter descriptions .....	12-30
12.6	Homing parameter (HOME) .....	12-32
12.6.1	Homing parameter descriptions .....	12-32
12.7	Ethernet setting (ETH.) .....	12-38
12.7.1	Ethernet parameter descriptions .....	12-38
12.8	Compensation parameter (COMP) .....	12-40
12.8.1	Compensation parameter descriptions .....	12-41
12.9	System parameter (SYSTEM) .....	12-44
12.9.1	System parameter descriptions .....	12-44
12.10	MLC setting (MLC) .....	12-52
12.10.1	MLC parameter descriptions .....	12-52
12.11	Graph parameter (GRAPHIC) .....	12-56
12.11.1	Graph parameter descriptions .....	12-56
12.12	Servo parameter (SERVO) .....	12-58
12.12.1	Servo parameter descriptions .....	12-58
12.13	Channel setting (CONFIG) .....	12-61
12.14	RIO setting .....	12-62
12.14.1	Details of RIO setting .....	12-63
12.14.2	Setting DA module (NC-EIO-DAC04) .....	12-65
12.15	Search (SEARCH) .....	12-66
12.16	Parameter group (PARAM GRP) .....	12-66
12.17	Other settings .....	12-68

# 12

12.17.1	Setting for absolute motor.....	12-68
12.17.2	Setting synchronous motion control .....	12-70
12.17.3	Command transfer .....	12-73

The PAR group is distinguished according to the functions into machining parameters, operation parameters, tool magazine parameters, spindle parameters, machine parameters, home parameters, network settings, compensation parameters, system parameters, MLC settings, graphic parameters, servo parameters, channel settings, RIO settings and parameter group functions.

The operation steps for modifying parameters are as follows:

- (1) Press **PAR** to enter the Parameter (Group) screen.
- (2) Press the function buttons F1 - F6 to enter the setting screen of the parameter to modify.
- (3) Press  and  to move the cursor to the specified field, and enter a value within the range specified in the lower right corner of the screen.
- (4) Press **ENTER** to complete the setting.

The timing for parameters to take effect is divided into three types according to their properties: after cycling power to the servo drive (S), after cycling power to the system (P), or after pressing **RESET** (R). You can determine the corresponding operations based on the red (P), (R) and (S) texts displayed at the top-right corner of the screen after changing the parameters.

Note:

1. **Function names** in a box (such as **POS**) mean the keys on machine operation panel A; bold **function names** (such as CLR ALL) mean the function keys of F1 - F6.
2. In the PAR screen, enter "S + parameter number" and you are directed to the specified parameter immediately.

## 12.1 Machining parameter (PROCESS)

Settings for machining parameters include maximum cutting speed, acceleration and deceleration times for cutting and smoothing, and other parameter settings for computation functions. It can have prominent effects on the machining results. Properly set the values according to the actual requirements to achieve the best performance.

### 12.1.1 Machining parameter descriptions

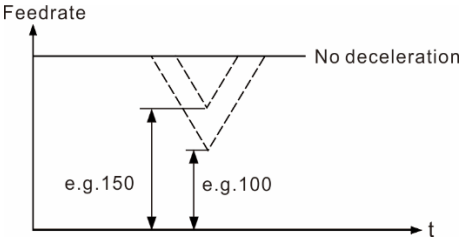
Parameter No.	Item	Description	Default value	Setting range	Note
309	Arc cutting reference feed rate	During circular interpolation, the arc shifts inward because of the delayed following of the servo. With the shift amount fixed, you can set the maximum feed rate of the arc radius with this parameter. The higher the parameter value, the greater the shift amount and the lower the machining precision, and vice versa. Unit: mm/min	1000	10 - 50000	R
310	Min. arc reference feed rate	Sets the minimum feed rate for executing circular interpolation. The higher the feed rate, the less precise the machining and the more the contouring error, while it shortens the machining time. Unit: mm/min	500	10 - 50000	R
311	Max. corner reference feed rate	Sets the speed limit at corners. The higher the value, the easier to keep the high speed at corners for restoring to the feed rate before deceleration. Setting the value too high or improper setting may cause vibration of the machine at the corners. Unit: mm/min 	100	0 - 50000	R
314	Default cutting feed rate	Sets the default cutting speed. When the parameter has setting value, when the cutting command did not specify a F value, the cutting speed will specify this parameter value as the default cutting speed. Unit: mm/min, inch/min	0	0 - 20000	P
315	G00 feed rate at 0% (override)	Sets the feed rate for rapid traverse when the rapid traverse override is set to 0%. Unit: mm/min, inch/min	100	10 - 10000	P
316	G00 feed rate	Sets the maximum speed of each axis for RAPID mode and G00. Unit: mm/min, inch/min	5000	1 - 600000	R
317	G00 ACC/DEC time constant	Sets the acceleration and deceleration time for rapid traverse. Unit: msec	200	1 - 2000	R
318	Max. cutting feed rate	Sets the maximum cutting feed rate. Unit: mm/min, inch/min	5000	1 - 600000	R

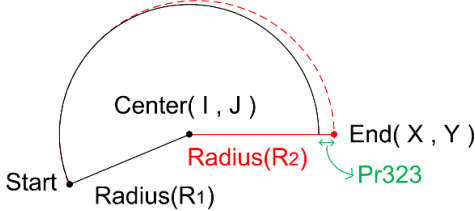
Parameter No.	Item	Description	Default value	Setting range	Note
319	Cutting ACC/DEC time constant	Sets the acceleration and deceleration time for cutting speed. Unit: msec (acceleration and deceleration time before interpolation)	200	1 - 2000	R
320	Cutting S-curve time constant	Sets the S-curve time for cutting speed. Unit: msec (acceleration and deceleration time before interpolation)	20	1 - 2000	R
321	Cutting post ACC/DEC time constant	Sets the post acceleration and deceleration time for cutting speed. The higher the value, the more the contouring error. Unit: msec (acceleration and deceleration time after interpolation)	50	1 - 500	R
322	S-curve time constant after cutting	Sets the post acceleration/deceleration S-curve time. Unit: msec (ACC / DEC after interpolation)	10	1 - 100	R
323	Arc radius tolerance	 <p>When the circular path is specified in center format (I, J, K), the controller calculates the radius <math>R_1</math> (the distance from the start point to the circle center) and the radius <math>R_2</math> (the distance from the end point to the circle center). The absolute difference between <math>R_1</math> and <math>R_2</math> should be smaller than Pr323 (<math> R_1 - R_2  &lt; Pr323</math>), or alarm B00D Radius mismatch occurs. Unit: <math>\mu\text{m}</math></p>	1	1 - 60000	R
329	Max. block length of path smoothing	When the system performs curve fitting, if the block length of G01 exceeds the setting in Pr329, the curve fitting for the block is automatically canceled and the linear interpolation remains effective. Unit: 0.1 mm	20	0 - 10000	R
330	Min. corner angle of path smoothing	When the angle specified by a single block exceeds the minimum angle of curve fitting, the curve fitting for the corner is automatically canceled and the sharpness is kept. Unit: degree	15	0 - 90	R
331	Length for corner detection	It sets the minimum length for corner detection. If the corner is formed of paths that are too short, the system keeps looking for the adjacent paths that are long enough and then start calculating the corner angle. Unit: 0.0001 mm	100	0 - 10000	R
332	Tolerance of single-block path smoothing	To have a smoother machining path, the smoothing function automatically adjusts the coordinates assigned in a single block and this parameter sets the adjustable distance. The greater the value, the smoother the path in the block, but the path is more unlikely to pass the coordinates set in the block. When the value is smaller, its fitting curve will be closer to the coordinates specified by the original program. Unit: 0.0001 mm	0	0 - 10000	R

12

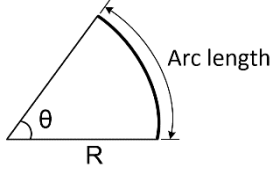
Parameter No.	Item	Description	Default value	Setting range	Note
333	Tolerance of path smoothing	Cosine error for curve fitting. The greater the value, the smoother the curve. But if the tolerance is set too great, the more the contouring error. The smaller the value, the more likely the machining contour is close to the programmed path for linear interpolation, but the curve is less smooth. It is suggested that the parameter value and the error value set in the CAM software should be consistent so as to make the path smoother without affecting the precision. Unit: 0.0001 mm	100	0 - 50000	R
344	Radius of rotation axis	<p>Sets the radius for the rotation axis. The greater the value, the slower the rotation speed and vice versa.</p> <p>Setting it to 0 disabled this function; at this time, the feed rate of the rotation axis is F (deg/min).</p> <p>When set to a non-zero value, the system defines this value as the radius of the rotation axis to calculate the arc length, and performs interpolation based on the arc length.</p> <p>Meanwhile, the feed rate for the rotation axis is determined by the F value (mm/min).</p>  $Arc\ length\ (mm) = \frac{\theta}{180} R\pi$ <p>The default unit of feed rate for linear axes is mm/min and that for the rotation axis is deg/min. If the rotation axis used in the application requires the feed rate to be consistent with the tangential velocity (mm/min), this function can be enabled; you can set Pr344 with the setting value as close as the distance between the cutting point and the rotation center (rotation radius). The smaller the value of Pr344, the faster the cutting speed; the greater the value of Pr344, the slower the cutting speed. Unit: 0.1 mm</p>	0	0 - 2000	R (Woodworking machine only)
510	Block No. to check in tool comp. interference	Sets the number of blocks to check in tool compensation interference: Pr510 = 0: number of blocks = 3 Pr510 < 3: number of blocks = Pr510	0	0 - 3	P
511	G00 S-curve time constant	Sets the acceleration and deceleration S-curve for the G00 movement. Unit: msec	1	0 - 2000	R

## 12.2 Operating parameter (OPERATE)

During G code program execution, macro program execution and computation can be used to achieve combined compound movements.

You can set whether to execute specified macro programs or controls in the Operation screen.

### 12.2.1 Operating parameter descriptions

Parameter No.	Item	Description	Default value	Setting range	Note	
3 - 12	G-code macro call - O9010 to O9019	G code macro call-O9010 Set these parameters to 0 to disable macro call.	0	0 - 1000	R	
		G code macro call-O9011				
		G code macro call-O9012				
		G code macro call-O9013				
		G code macro call-O9014				
		G code macro call-O9015				
		G code macro call-O9016				
		G code macro call-O9017				
		G code macro call-O9018				
		G code macro call-O9019				
13 - 22	M-code macro call - O9020 to O9029	M code macro call-O9020 Set these parameters to 0 to disable macro call.	0	0 - 1000	R	
		M code macro call-O9021				
		M code macro call-O9022				
		M code macro call-O9023				
		M code macro call-O9024				
		M code macro call-O9025				
		M code macro call-O9026				
		M code macro call-O9027				
		M code macro call-O9028				
		M code macro call-O9029				
23	T code macro call - O9000	T code macro call-O9000 0: off; 1: on	0	0 - 1	R	
24	Call O9030 after break line search	Call O9030 after break line search. 0: function disabled. After finding the break line, the system continues executing the program without calling a macro. 1: function enabled. After finding the break line, the system first calls and executes O9030 once <b>CYCLE START</b> is pressed, and then it returns to the main program and carries on the machining program followed by the breakpoint.	0	0 - 1	R	
25	System DIO setting	Sets G31 input polarity. 0: NC; 1: NO	0	0 - 1	P	
		Function				Range
		G31 high speed input point 1				0 - 1
		G31 high speed input point 2				0 - 1



12

Parameter No.	Item	Description	Default value	Setting range	Note						
46	System application setting	Function	Range	96	0 - 0xFFFF	P					
		Control output control mode 0: DMCNET	0								
		Homing before machining 0: Y; 1: N	0 - 1								
		Screw unit 0: metric; 1: imperial	0 - 1								
		G31 high speed input 1 switch 0: off; 1: on	0 - 1								
		G31 high speed input point 2 switch 0: off; 1: on	0 - 1								
		Hardware limit check 0: off; 1: on	0 - 1								
		Software limit check 0: off; 1: on	0 - 1								
		Ignore decimal places of moving commands 0: do not omit (example: input 1 to indicate 1 μm) 1: omit (example: input 1 to indicate 1 mm)	0 - 1								
		Function	Range				96	0 - 0xFFFF	P		
	G00 operation mode 0: rapid feeding by multi-axis linear interpolation (same as G01) 1: refers to the maximum feed rate of each axis	0 - 1									
	Macro look-ahead 0: off; 1: on	0 - 1									
	G00 path blending mode 0: same axis; 1: different axes The greater the setting value of Pr334, the larger the chamfer of the path.	0 - 1									
47	MGP gain	MPG filter gain. For setting the MPG response. The greater the value, the faster the response, but the machine is subject to vibration. Unit: 0.0001	100	1 - 60000	R						
48	MPG filter	Sets the MPG filter. 0: disabled	0	0 - 6	R						
		Level				1	2	3	4	5	6
		kHz				31	10	5	2.5	1.6	1.2
49	Axis port input setting	0: the 4 <sup>th</sup> axis includes both limit and home signals 1: Changes the positive limit signal, negative limit signal, and home signal of the 4 <sup>th</sup> axis in axis ports 1 - 4 to the home signals of the 4 <sup>th</sup> , 5 <sup>th</sup> , and 6 <sup>th</sup> axes.	0	0 - 1	R						
50	Macro file display	Function	Range	0	0 - 3	P					
		Display O macro file	0 - 1								
		Display G/M macro file	0 - 1								

Parameter No.	Item	Description		Default value	Setting range	Note
51	System auxiliary tool	Function	Range	0	0 - 1	P
		Spindle check before cutting: when this function is enabled, if a cutting command is executed but the spindle is not in operation, the system displays an alarm. 0: off; 1: on	0 - 1			
		Non-volatile setting for #10450 - #10500 0: on; 1: off	0 - 1			
51	System auxiliary tool	Function	Range	0	0 - 1	P
		Tool radius compensation first point compensation mode 0: Type B; 1: Type A	0 - 1			
		G54 - G59 offset coordinate switch 0: off; 1: on	0 - 1			
		Stroke protection: When this function is enabled, the Pr611 and Pr612 stroke protection edge function will be enabled. 0: off; 1: on	0 - 1			
		1 <sup>st</sup> spindle OA/OB signal sequence 0: AB; 1: BA	0 - 1			
		Return mode after triggering M96 0: go to the next line; 1: return to the interrupted line	0 - 1			
		G94 / G95 default setting 0: program; 1: Pr306	0 - 1			
		Draw coordinate selection 0: Machine; 1: absolute	0 - 1			
		MPG backtrack function: supports the backtracking of 30 blocks 0: off; 1: on	0 - 1			
Feedback check 0: on; 1: off	0 - 1					
301	Unit decimal places	Unit setting for coordinate display. For example, when you set this parameter to 3, the coordinates are displayed with three decimal places, such as -99999.999 to +99999.999		3	0 - 4	P
305	Channel auxiliary setting	Function	Range	0	362	P
		T code read mode (0: keep T; 1: clear) 0: After T code calls O9000 and reads #20 repeatedly, keep the last T value (default) 1: after T code calls O9000 and reads #20 repeatedly, the value read is 0	0 - 1			
		EMG stop source 0: system; 1: M1079	0 - 1			
		G0 / G1 transition speed 0: decelerate to zero speed 1: do not decelerate (according to the setting of Pr334)	0 - 1			

12

Parameter No.	Item	Description		Default value	Setting range	Note
		Function	Range			
305	Channel auxiliary setting	Run macro program in advance with T code: When the program runs to a few line block before calling the T code of the subroutine O9000 (the number of lines for T code to run macro program in advance can be set through Pr507), call the subroutine automatically (the number of the macro program for T code to run in advance can be set through Pr506). Once entered the subroutine, the T code tool number can be read at #20, and it supports multi-T commands. 0: off; 1: on	0 - 1	0	362	P
		Record machine coordinates after triggering HSI 0: command; 1: feedback	0 - 1			
		MLC axis positioning command type: 0: floating point number; 1: integer When set as floating point number, the positioning command special D and machine coordinates special D of the MLC axis are both displayed in floating point number format. If set as integer format, the command refers to Pr301 [Number of decimal places of the unit] and corresponds to the special D of MLC positioning machine coordinates and machine coordinates.	0 - 1			
		JOG speed mode: When enabled, it will change the unit of D1062 (JOG and dry run speed setting) from speed (F) to percentage (%), and its limit is 100%. The numerical specifications are the same as D1056 and D1058. At this time, the JOG speed is Pr640×D1062 (%). 0: Speed; 1: %	0 - 1			
		Special D rotation axis coordinates display range 0: The display range is [-360, 360] 1: The display range is [0, 360]	0 - 1			
		Short block feed rate limit 0: function disabled 1: function enabled Related parameters: Pr504 short block feed rate limit length (0.1 mm), Pr505 short block feed rate limit speed magnification (0.1%). When this function is enabled, when the block length is less than the setting of Pr504, the block speed = Pr505 parameter setting deceleration percentage*G code specified F.	0 - 1			
		Preview function referencing cutting speed override Sets whether to refer to the cutting speed override during preview 0: do not refer to cutting magnification during preview. Use the highest speed to preview straight lines and refer to the speed set in D1150 to preview arcs. When the setting of D1150 is less than 80000 mm/min, the system performs drawing preview at 80000 mm/min.	0 - 1			

Parameter No.	Item	Description	Default value	Setting range	Note												
		<p>1: refer to cutting magnification during preview.</p> <ul style="list-style-type: none"> <li>■ When cutting speed override <math>\geq</math> 100%, use the highest speed to preview straight lines and refer to the speed set in D1150 to preview arcs.</li> <li>■ 0% &lt; cutting speed override &lt; 100%, the preview speed of straight line and arc refers to the setting of [Pr316*cutting speed override]</li> <li>■ Cutting speed override = 0%, the straight line and arc preview speeds are F specified in the G code.</li> </ul>															
		<p>RAPID mode maximum speed limit reference: In RAPID mode, the reference of the maximum speed of each axis can be determined by this parameter.</p> <p>0: refer to the axis parameter Pr621 for the maximum speed of each axis in RAPID mode.</p> <p>1: refer to the axis parameter Pr638 for the maximum speed of each axis in RAPID mode.</p>		0 - 1													
306	G-code programming parameter	<table border="1"> <thead> <tr> <th>Function</th> <th>Range</th> </tr> </thead> <tbody> <tr> <td>Default unit 0: metric; 1: imperial</td> <td>0 - 1</td> </tr> <tr> <td>Default programming mode 0: absolute; 1: incremental</td> <td>0 - 1</td> </tr> <tr> <td>Default feed mode 1: feed per minute 0: feed per rotation</td> <td>0 - 1</td> </tr> <tr> <td>Default plane 0: G17 1: G18 2: G19</td> <td>0 - 2</td> </tr> <tr> <td>Default workpiece coordinates 0: G54 1: G55 2: G56 3: G57 4: G58 5: G59</td> <td>0 - 5</td> </tr> </tbody> </table>	Function	Range	Default unit 0: metric; 1: imperial	0 - 1	Default programming mode 0: absolute; 1: incremental	0 - 1	Default feed mode 1: feed per minute 0: feed per rotation	0 - 1	Default plane 0: G17 1: G18 2: G19	0 - 2	Default workpiece coordinates 0: G54 1: G55 2: G56 3: G57 4: G58 5: G59	0 - 5	0	0 - 1	P
		Function	Range														
		Default unit 0: metric; 1: imperial	0 - 1														
		Default programming mode 0: absolute; 1: incremental	0 - 1														
		Default feed mode 1: feed per minute 0: feed per rotation	0 - 1														
Default plane 0: G17 1: G18 2: G19	0 - 2																
Default workpiece coordinates 0: G54 1: G55 2: G56 3: G57 4: G58 5: G59	0 - 5																
	<table border="1"> <thead> <tr> <th>Function</th> <th>Range</th> </tr> </thead> <tbody> <tr> <td>Tool length compensation movement mode 0: immediately. When the block has a tool length compensation execution or cancellation command without a Z axis command, Z axis moves.</td> <td>0 - 1</td> </tr> <tr> <td>1: program. When the block has a tool length compensation execution or cancellation command without a Z axis command, Z axis will not move.</td> <td></td> </tr> </tbody> </table>	Function	Range	Tool length compensation movement mode 0: immediately. When the block has a tool length compensation execution or cancellation command without a Z axis command, Z axis moves.	0 - 1	1: program. When the block has a tool length compensation execution or cancellation command without a Z axis command, Z axis will not move.		0xD4	0 - 0xFFFF	P							
Function	Range																
Tool length compensation movement mode 0: immediately. When the block has a tool length compensation execution or cancellation command without a Z axis command, Z axis moves.	0 - 1																
1: program. When the block has a tool length compensation execution or cancellation command without a Z axis command, Z axis will not move.																	
	<table border="1"> <thead> <tr> <th>Function</th> <th>Range</th> </tr> </thead> <tbody> <tr> <td>Spindle speed after reset 0: command speed remains after reset 1: command speed becomes 0 after reset</td> <td>0 - 1</td> </tr> </tbody> </table>	Function	Range	Spindle speed after reset 0: command speed remains after reset 1: command speed becomes 0 after reset	0 - 1												
Function	Range																
Spindle speed after reset 0: command speed remains after reset 1: command speed becomes 0 after reset	0 - 1																

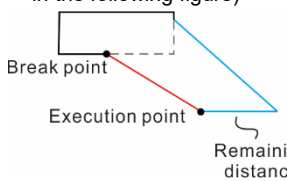
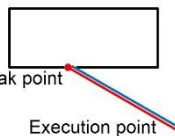
Parameter No.	Item	Description	Default value	Setting range	Note
		<p>Software limit check mode</p> <p>0: checks the program path machine coordinates when software limit checking</p> <p>1: checks the tool path machine coordinates software limit checking</p>	0 - 1		
		<p>Tool length input mode</p> <p>Sets whether to deduct the tool length (assigned by H1) during tool length compensation using the H value in G43/G44.</p> <p>0: absolute (uses the length assigned by H)</p> <p>1: incremental (deducts the length of the first tool from the assigned H value)</p>	0 - 1		
		<p>G31 input source</p> <p>0: off</p> <p>1: HSI 1</p> <p>2: HSI 2</p> <p>3: HSI 1 &amp; 2</p>	0 - 3		
		<p>Running mode after interruption</p> <p>0: during the execution of a block, if you manually move the tool from its original position and then resumes the program execution, the tool moves the remaining distance first and then returns to the original path in the next motion block. (As shown in the following figure)</p>  <p>1: during the execution of a block, if you manually move the tool from its original position and then resumes the program execution, the tool returns to the original path first and then moves the remaining distance. (As shown in the following figure)</p> 	0 - 1		
		<p>Software limit alarm trigger mode</p> <p>0: trigger the alarm when software limit setting is exceeded.</p> <p>When the machine coordinates exceed the software limit setting, the alarm occurs.</p> <p>1: trigger the alarm when software limit setting is reached or exceeded.</p> <p>When the machine coordinates exceeded or is equal to the software limit setting value, alarm occurs.</p>	0 - 1		
		<p>EMG stop mode</p> <p>0: after the controller stops, the servo switches to Servo Off</p> <p>1: after the controller stops, the servo stops and switches to Servo Off</p> <p>2: after the controller stops, the servo</p>	0 - 2		

Parameter No.	Item	Description	Default value	Setting range	Note
		stops			
		MLC variable type 0: word type 1: double word type Set this bit to 1 to change the interface input / output registers to 8 sets (32-bit) from 16 sets (16-bit).			
		G00/G01 max. feed rate reference 0: resultant velocity. For the maximum feed rate limit of G0, refer to the machining parameter Pr316 and operation parameter Pr621; for the maximum feed rate limit for G1, refer to the machining parameter Pr318 and the operation parameter Pr625. 1: individual velocity. The maximum feed rate limit of G0, does not refer to the operation parameter Pr316, but refers to the operation parameter Pr621; the maximum feed rate limit for G1, does not refer to the machining parameter Pr318, but refers to the operation parameter Pr625.			
		Return mode after interruption 0: G00, uses G00 mode to return to the interruption 1: G01, uses G01 mode to return to the interruption			
		Synchronous execution for M, S, and T codes and G00 0: off; execute M, S, and T codes first and then G00. 1: on; execute M, S, and T codes and G00 synchronously.			
		Cancel tool radius compensation for G00 block 0: Off; execute tool radius compensation for the G00 block. 1: On; temporarily cancels tool radius compensation for the G00 block.			
308	Channel auxiliary setting	Function	Range		
		feed rate reference 0: program; 1: refers to Pr314	0 - 1		
		Local variable NULL function 0: off; #1 - #50 are 0 1: on; #1 - #50 are null	0 - 1		
		Current monitoring function 0: off; 1: on	0 - 1		
		Tool compensation interference check 0: on; 1: off	0 - 1		
		Motion speed remains when coordinates switch 0: off; 1: on	0 - 1		
		Motion speed remains when macro call 0: off; 1: on	0 - 1		
			0	0 - 0xFFFF	P

Parameter No.	Item	Description	Default value	Setting range	Note						
		<p>Dynamic axis compensation function</p> <p>0: Off. Disalbe the equal slope filter compensation function and retains the filter output to prevent the motor from suddenly reversing to the position before compensation enabled.</p> <p>1: On. Enalbe the equal slope filter compensation function. The corresponding special D range of each axis is D1126 - D1146.</p>									
		<p>Pause before running M99</p> <p>0: M99 continues to run the functions</p> <p>1: pause before running M99</p>									
		<p>Tool number display mode</p> <p>The special D in MLC controls the display function of the spindle tool number, standby tool number and command tool number on the POS page. Spindle tool number: D1172; standby tool number: D1173; command tool number: D1174</p> <p>0: G code</p> <p>1: D1172</p>									
		<p>Feed/rev mode reference</p> <p>0: command; refer to the spindle command speed for the calculation of the cutting speed in feed/rev mode</p> <p>1: feedback; refer to the spindle feedback speed for the calculation of the cutting speed in feed/rev mode</p>									
324	Peck-drilling escape amount	Set the retreat amount of drill chip removal. Unit: μm	100	1 - 50000	R						
326	Cycle parameter	<table border="1"> <thead> <tr> <th>Function</th> <th>Range</th> </tr> </thead> <tbody> <tr> <td>Tool withdraw direction (for setting the withdraw direction of the G76 / G87 cycle command tool) 0: +X; 1: -X; 2: +Y; 3: -Y</td> <td>0 - 3</td> </tr> <tr> <td>Tapping mode 0: general 1: deep-pecking (feed amount = Q, retract amount = R) 2: pecking (feed amount = Q, retract amount = D)</td> <td>0 - 2</td> </tr> </tbody> </table>	Function	Range	Tool withdraw direction (for setting the withdraw direction of the G76 / G87 cycle command tool) 0: +X; 1: -X; 2: +Y; 3: -Y	0 - 3	Tapping mode 0: general 1: deep-pecking (feed amount = Q, retract amount = R) 2: pecking (feed amount = Q, retract amount = D)	0 - 2	0	0 - 0xFFFF	R
		Function	Range								
Tool withdraw direction (for setting the withdraw direction of the G76 / G87 cycle command tool) 0: +X; 1: -X; 2: +Y; 3: -Y	0 - 3										
Tapping mode 0: general 1: deep-pecking (feed amount = Q, retract amount = R) 2: pecking (feed amount = Q, retract amount = D)	0 - 2										
327	EMG stop time constant	Sets the time for the servo motor to decelerate to zero speed when the emergency stop is pressed in AUTO mode. Unit: msec	50	5 - 500	R						
328	EMG stop delay time	Sets the delay time for the special M relay M2114 System emergency stop when the system is stopped and in Servo Off status. Unit: msec	35	0 - 2000	R						
334	G00 blending ratio	The speed does not decelerate to zero when G00 is executed between blocks. Use this parameter to set the blending ratio. The greater the value, the less the deceleration at block transitions and the faster the speed; the smaller the value, the more the deceleration at block transitions and the slower the speed. Unit: %	0	0 - 100	R						
350 - 359	Halt M code 1 - 10	Halt M code 1	0	0 - 1000	P						
		0: no setting									
		Halt M code 2									
		Halt M code 3									

Parameter No.	Item	Description	Default value	Setting range	Note																				
		Halt M code 4																							
		Halt M code 5																							
		Halt M code 6																							
		Halt M code 7																							
		Halt M code 8																							
		Halt M code 9																							
		Halt M code 10																							
360	Synchronization direction control	Synchronization direction control Bit 0 - 8: synchronous control of X - W 0: same direction 1: different directions <table border="1" style="width: 100%; border-collapse: collapse;"> <thead> <tr> <th style="width: 80%;">Function</th> <th>Range</th> </tr> </thead> <tbody> <tr> <td>Synchronous direction for X axis</td> <td>0 - 1</td> </tr> <tr> <td>Synchronous direction for Y axis</td> <td>0 - 1</td> </tr> <tr> <td>Synchronous direction for Z axis</td> <td>0 - 1</td> </tr> <tr> <td>Synchronous direction for A axis</td> <td>0 - 1</td> </tr> <tr> <td>Synchronous direction for B axis</td> <td>0 - 1</td> </tr> <tr> <td>Synchronous direction for C axis</td> <td>0 - 1</td> </tr> <tr> <td>Synchronous direction for U axis</td> <td>0 - 1</td> </tr> <tr> <td>Synchronous direction for V axis</td> <td>0 - 1</td> </tr> <tr> <td>Synchronous direction for W axis</td> <td>0 - 1</td> </tr> </tbody> </table>	Function	Range	Synchronous direction for X axis	0 - 1	Synchronous direction for Y axis	0 - 1	Synchronous direction for Z axis	0 - 1	Synchronous direction for A axis	0 - 1	Synchronous direction for B axis	0 - 1	Synchronous direction for C axis	0 - 1	Synchronous direction for U axis	0 - 1	Synchronous direction for V axis	0 - 1	Synchronous direction for W axis	0 - 1	0	0 - 0x3F	P
Function	Range																								
Synchronous direction for X axis	0 - 1																								
Synchronous direction for Y axis	0 - 1																								
Synchronous direction for Z axis	0 - 1																								
Synchronous direction for A axis	0 - 1																								
Synchronous direction for B axis	0 - 1																								
Synchronous direction for C axis	0 - 1																								
Synchronous direction for U axis	0 - 1																								
Synchronous direction for V axis	0 - 1																								
Synchronous direction for W axis	0 - 1																								
361	Synchronous control X	Specifies the master axis when X axis is the slave axis. For example, set this parameter to 2 if desiring to set the Y axis as the master axis for synchronous control. 0: disabled; 1 - 9: X - W	0	0 - 9	P																				
362	Synchronous control Y	Specifies the master axis when Y axis is the slave axis. 0: disabled; 1 - 9: X - W	0	0 - 9	P																				
363	Synchronous control Z	Specifies the master axis when Z axis is the slave axis. 0: disabled; 1 - 9: X - W	0	0 - 9	P																				
364	Synchronous control A	Specifies the master axis when A axis is the slave axis. 0: disabled; 1 - 9: X - W	0	0 - 9	P																				
365	Synchronous control B	Specifies the master axis when B axis is the slave axis. 0: disabled; 1 - 9: X - W	0	0 - 9	P																				
366	Synchronous control C	Specifies the master axis when C axis is the slave axis. 0: disabled; 1 - 9: X - W	0	0 - 9	P																				
367	Synchronous control U	Specifies the master axis when U axis is the slave axis. 0: disabled; 1 - 9: X - W	0	0 - 9	P																				
368	Synchronous control V	Specifies the master axis when V axis is the slave axis. 0: disabled; 1 - 9: X - W	0	0 - 9	P																				
369	Synchronous control W	Specifies the master axis when W axis is the slave axis. 0: disabled; 1 - 9: X - W	0	0 - 9	P																				



Parameter No.	Item	Description	Default value	Setting range	Note
371	Transfer control X	Specifies the X axis as the axis to receive the transfer command. When transfer control function is enabled, the command is transferred to have the X axis move while the originally commanded axis does not move. For example, set this parameter to 2 if desiring to transfer the control command from the Y axis. 0: disabled; 1 - 9: X - W	0	0 - 9	P
372	Transfer control Y	Specifies the Y axis as the axis to receive the transfer command. When transfer control function is enabled, the command is transferred to have the Y axis move while the originally commanded axis does not move. 0: disabled; 1 - 9: X - W	0	0 - 9	P
373	Transfer control Z	Specifies the Z axis as the axis to receive the transfer command. When transfer control function is enabled, the command is transferred to have the Z axis move while the originally commanded axis does not move. 0: disabled; 1 - 9: X - W	0	0 - 9	P
374	Transfer control A	Specifies the A axis as the axis to receive the transfer command. When transfer control function is enabled, the command is transferred to have the A axis move while the originally commanded axis does not move. 0: disabled; 1 - 9: X - W	0	0 - 9	P
375	Transfer control B	Specifies B axis as the axis to receive the transfer command. When transfer control function is enabled, the command is transferred to have the B axis move while the originally commanded axis does not move. 0: disabled; 1 - 9: X - W	0	0 - 9	P
376	Transfer control C	Specifies the C axis as the axis to receive the transfer command. When transfer control function is enabled, the command is transferred to have the C axis move while the originally commanded axis does not move. 0: disabled; 1 - 9: X - W	0	0 - 9	P
377	Transfer control U	Specifies U axis as the axis to receive the transfer command. When transfer control function is enabled, the command is transferred to have the U axis move while the originally commanded axis does not move. 0: disabled; 1 - 9: X - W	0	0 - 9	P
378	Transfer control V	Specifies the V axis as the axis to receive the transfer command. When transfer control function is enabled, the command is transferred to have the V axis move while the originally commanded axis does not move. 0: disabled; 1 - 9: X - W	0	0 - 9	P
379	Transfer control W	Specifies W axis as the axis to receive the transfer command. When transfer control function is enabled, the command is transferred to have the W axis move while the originally commanded axis does not move. 0: disabled; 1 - 9: X - W	0	0 - 9	P

Parameter No.	Item	Description		Default value	Setting range	Note
		Function	Range			
485	Channel application setting	<p>[MPG backtrack setting when running to M, S, and T codes]</p> <p>When using the MPG to backtrack to a specific line and encounter an M, S, or T code, the M, S, and T codes can be skipped.</p> <p>0: stop backtracking when encountering the M, S, or T code.</p> <p>1: skip the M, S, and T codes when using the MPG to backtrack.</p>	0 - 1	0	0 - 65535	P
		<p>[Homing speed refers to feedrate override setting]</p> <p>This parameter sets to refer to the feedrate override setting when homing.</p> <p>0: off; not refer to the feedrate override setting.</p> <p>1: on; refer to D1056 for the hard stop searching speed and homing speed</p>	0 - 1			
		<p>[MPG simulation when homing]</p> <p>0: off</p> <p>1: on; perform the homing procedure with MPG.</p>	0 - 1			
		<p>[Lock axis positive / negative movement in AUTO mode]</p> <p>When the special M corresponding to the axial is triggered, the system in JOG or MPG mode checks the current operating direction and lock the axis movement.</p> <p>In HOME mode, once any of the special M corresponding to the axis movement is triggered, the homing procedure stops.</p> <p>When an arc command is executed, the system also checks the operating direction.</p> <p>0: off</p> <p>1: enable the positive and negative axis lock in AUTO mode</p>	0 - 1			
501	Axis movement protection setting	<p>X axis movement protection</p> <p>This parameter sets the axis movement protection. You can enable the protection function for specific axes. When function enabled, if there is axis movement in the block, the axis can move only when the corresponding special M relays (M2400 – 2408)</p> <p>0: off</p> <p>1: enable movement protection</p>	0 - 1	0	0 - 1	P
		<p>Y axis movement protection</p> <p>0: off</p> <p>1: enable movement protection</p>	0 - 1			
		<p>Z axis movement protection</p> <p>0: off</p> <p>1: enable movement protection</p>	0 - 1			
		<p>A axis movement protection</p> <p>0: off</p> <p>1: enable movement protection</p>	0 - 1			
		<p>B axis movement protection</p> <p>0: off</p>	0 - 1			

Parameter No.	Item	Description	Default value	Setting range	Note
		1: enable movement protection C axis movement protection 0: off 1: enable movement protection 0 - 1			
		U axis movement protection 0: off 1: enable movement protection 0 - 1			
		V axis movement protection 0: off 1: enable movement protection 0 - 1			
		W axis movement protection 0: off 1: enable movement protection 0 - 1			
504	Short block feed rate limit length	Short block feed rate limit length (0.1 mm), this function switch is the auxiliary setting of the Pr305 channel - short block feed rate limit. Note: Please refer to the related parameter Pr505.	0	0 - 65535	R
505	Short block feed rate limit length speed magnification	Short block feed rate limit length speed magnification (0.1%), when this function is enabled, when the block length is less than the setting of Pr504, block speed = Pr505 parameter setting deceleration percentage*specified F of G code. Note: Please refer to the related parameters Pr305 and Pr504.	0	0 - 1000	R
506	Run macro program in advance with T code	When the program runs to a few line block before calling the T code of the subroutine O9000 (the number of lines can be set through Pr507), call the subroutine automatically (the number of the macro program can be set through Pr506). Once entered the subroutine, the T code tool number can be read at #20, and it supports multiple T code commands.	0	0 - 9999	P
507	Number of lines to run macro program in advance with T code	When the program runs to a few line block before calling the T code of the subroutine O9000 (the number of lines can be set through Pr507), call the subroutine automatically (the number of the macro program can be set through Pr506). Once entered the subroutine, the T code tool number can be read at #20, and it supports multiple T code commands.	0	0 - 10	P
508	Polygon cutting axis setting	This function sets the spindle to the rotation axis mode. Use this parameter to set the rotation axis (tool axis) to use. 0: off 4 - 9: A - W	0	0 - 9	P
509	Torque limit for each axis	Torque limit for each servo axis (combined in binary); Bit 0 indicates X axis, Bit 1 indicates Y axis, Bit 2 indicates Z axis, and so on. For example, to enable the torque limit of X and Z axes, simply set Pr509 to 5.	0	0 - 65535	P
514	Feedback check time	When the command specifies a movement while it is not shown in the feedback and the movement exceeds the value set by Pr514, alarm 4FFD occurs. Unit: ms	0	0 - 65535	R

Parameter No.	Item	Description	Default value	Setting range	Note	
2005	Input source setup	Function	Range	0	0 - 61440	P
		Z axis high speed input point setting 0: off; 1: on	0 - 1			
		A axis high speed input point setting 0: off; 1: on	0 - 1			
		B axis high speed input point setting 0: off; 1: on	0 - 1			
		C axis high speed input point setting 0: off; 1: on	0 - 1			
2006	Input source setup	Function	Range	0	0 - 49155	P
		U axis high speed input point setting 0: off; 1: on	0 - 1			
		V axis high speed input point setting 0: off; 1: on	0 - 1			
		Origin / limit planning 0: off; 1: on	0 - 1			
		Emergency stop contact source 0: IES 1: CN1 emergency stop contact	0 - 1			
2010	High speed input trigger setting	Function	Range	0	0 - 65535	P
		HSI 1 trigger setting 0: rising-edge; 1: falling-edge	0 - 1			
		HSI 2 trigger setting 0: rising-edge; 1: falling-edge	0 - 1			
		Sets the high speed input rising-edge (set as 0) count; falling-edge (set as 1) count.				
2049	PMC module output setting	PMC module output setting 0: general (servo) 1: bridge (command = feedback)		0	0 - 65535	P
		Function	Range			
		1 <sup>st</sup> axis feedback source	0 - 1			
		2 <sup>nd</sup> axis feedback source	0 - 1			
		3 <sup>rd</sup> axis feedback source	0 - 1			
		4 <sup>th</sup> axis feedback source	0 - 1			
		5 <sup>th</sup> axis feedback source	0 - 1			
		6 <sup>th</sup> axis feedback source	0 - 1			
		7 <sup>th</sup> axis feedback source	0 - 1			
		8 <sup>th</sup> axis feedback source	0 - 1			
		9 <sup>th</sup> axis feedback source	0 - 1			
		10 <sup>th</sup> axis feedback source	0 - 1			
		11 <sup>th</sup> axis feedback source	0 - 1			
		12 <sup>th</sup> axis feedback source	0 - 1			
		Pulse command type 0: A/B Phase 1: CW/CCW 2: Pulse/Dir 3: A/B Phase (same as 0)	0 - 3			
Pulse logic 0: positive; 1: negative	0 - 1					

Parameter No.	Item	Description	Default value	Setting range	Note
2050	1st PMC encoder resolution (single-phase)	The motor single-frequency pulse number.	0	0 - 65535	P
2051	2nd PMC encoder resolution (single-phase)	The motor single-frequency pulse number.	0	0 - 65535	P
2052	3rd PMC encoder resolution (single-phase)	The motor single-frequency pulse number.	0	0 - 65535	P
2053	4th PMC encoder resolution (single-phase)	The motor single-frequency pulse number.	0	0 - 65535	P
2054	5th PMC encoder resolution (single-phase)	The motor single-frequency pulse number.	0	0 - 65535	P
2055	6th PMC encoder resolution (single-phase)	The motor single-frequency pulse number.	0	0 - 65535	P
2056	7th PMC encoder resolution (single-phase)	The motor single-frequency pulse number.	0	0 - 65535	P
2057	8th PMC encoder resolution (single-phase)	The motor single-frequency pulse number.	0	0 - 65535	P
2058	9th PMC encoder resolution (single-phase)	The motor single-frequency pulse number.	0	0 - 65535	P
2059	10th PMC encoder resolution (single-phase)	The motor single-frequency pulse number.	0	0 - 65535	P
601	Parallel axis of cylindrical interpolation rotation axis (1 - 3: X - Z)	Command format: Using C axis as the rotation axis for example, 1. G19 => first select the cylindrical coordinate interpolation machining plane 2. G07.1 C_ => enable the cylindrical coordinate interpolation, C_ : Set the radius of the milling cylinder 3. Description of the milling path 4. G07.1 C0. => disable the cylindrical interpolation	0	0 - 3	P
621	G00/manual maximum speed	Sets the maximum speed for G00 and manual movement. Unit: mm/min, inch/min, rpm	5000	0 - 600000	P
622	G00/manual ACC/DEC time	Sets the acceleration or deceleration time. Unit: msec	50	0 - 10000	P
623	S-curve time	Sets the time constant for S-curve. Unit: msec	5	1 - 2000	P
625	G01 maximum speed	Sets the maximum speed for G01.	0	0 - 60000	R

Parameter No.	Item	Description	Default value	Setting range	Note
638	RAPID mode maximum speed limit	Maximum speed limit of RAPID mode.	10	0 - 65535	R
640	100% JOG speed	JOG speed override is the maximum speed limit at 100%. Note: 1. Refer to Pr305 [Jog speed mode] on how to enable the function. 2. Refer to Pr621 [G00 and manual maximum speed limit] for speed limits.	0	0 - 65535	R
642	Synchronous tolerance	During synchronous control, if the following error between the master and slave axes exceeds this value, the B645 Excessive synchronous following error occurs. Unit: 0.1 mm	50	0 - 1000	R
643	Feedback following error	If the following error exceeds the setting in any movement, the B630 alarm occurs. This parameter is for setting the tolerance for the servo following command. Unit: CU	30000	1 - 60000	R
646	Position reached range	G00, G09, G61 position reached check function. When Pr646 position reached range (linear axis: 0.001 mm; rotation axis: 0.1 degrees) is not set as 0, the position reached check function for that axial is enabled. Once the position reached check function is enabled, the amount of error of the moving axial command and feedback (Cmd -Fbk) in the block must be less than the Pr646 parameter setting value of that axis in order to run the next block.	0	0 - 6000	R
648	Feedback position check after bootup	When bootup, the system checks the error between the command and the feedback from servo. If the error exceeds the setting, the servo cannot switch to Servo on.	20	1 - 6000	R

## 12.3 Tool magazine parameter (MAGA)

Tool magazine parameters are for enabling magazine-related functions. With these parameters, you can specify the type and number of magazines and determine whether to enable the tool magazine functions. Contact the distributors or equipment suppliers for settings of hardware parameters.

### 12.3.1 Tool magazine parameter descriptions

Parameter No.	Item	Description	Default value	Setting range	Note						
336	Tool magazine control	<table border="1"> <thead> <tr> <th>Function</th> <th>Range</th> </tr> </thead> <tbody> <tr> <td>Spindle tool No. after magazine reset 0: 0 1: continue numbering</td> <td>0</td> </tr> <tr> <td>Types of ATC 0: exchange arm (Exchanger) 1: disk (Non-exchanger)</td> <td>0 - 1</td> </tr> </tbody> </table>	Function	Range	Spindle tool No. after magazine reset 0: 0 1: continue numbering	0	Types of ATC 0: exchange arm (Exchanger) 1: disk (Non-exchanger)	0 - 1	0x0800	0 - 65535	P
		Function	Range								
Spindle tool No. after magazine reset 0: 0 1: continue numbering	0										
Types of ATC 0: exchange arm (Exchanger) 1: disk (Non-exchanger)	0 - 1										
<table border="1"> <thead> <tr> <th>Function</th> <th>Range</th> </tr> </thead> <tbody> <tr> <td>Tool magazine 1 0: off (tool magazine data table is not updated instantly) 1: on (tool magazine data table is updated instantly)</td> <td>0 - 1</td> </tr> <tr> <td>Enable tool magazine 2 0: off 1: enable</td> <td>0 - 1</td> </tr> </tbody> </table>	Function	Range	Tool magazine 1 0: off (tool magazine data table is not updated instantly) 1: on (tool magazine data table is updated instantly)	0 - 1	Enable tool magazine 2 0: off 1: enable	0 - 1					
Function	Range										
Tool magazine 1 0: off (tool magazine data table is not updated instantly) 1: on (tool magazine data table is updated instantly)	0 - 1										
Enable tool magazine 2 0: off 1: enable	0 - 1										
337	Tool magazine switch	<table border="1"> <thead> <tr> <th>Function</th> <th>Range</th> </tr> </thead> <tbody> <tr> <td>Tool magazine 1 0: off (tool magazine data table is not updated instantly) 1: on (tool magazine data table is updated instantly)</td> <td>0 - 1</td> </tr> <tr> <td>Enable tool magazine 2 0: off 1: enable</td> <td>0 - 1</td> </tr> </tbody> </table>	Function	Range	Tool magazine 1 0: off (tool magazine data table is not updated instantly) 1: on (tool magazine data table is updated instantly)	0 - 1	Enable tool magazine 2 0: off 1: enable	0 - 1	1	0 - 3	P
Function	Range										
Tool magazine 1 0: off (tool magazine data table is not updated instantly) 1: on (tool magazine data table is updated instantly)	0 - 1										
Enable tool magazine 2 0: off 1: enable	0 - 1										
338	Tool magazine 1 total tool No.	Sets the number of tool stations of tool magazine 1 (in response to the mechanical differences of tool magazines, you need to set the number of the placeable tools with this parameter).	10	2 - 255	P						
339	Tool magazine 1 standby tool No. after reset	Sets the standby tool pocket number when the reset function is used for tool magazine 1.	1	1 - 100	P						
340	Tool magazine 1 start tool No.	Sets the tool number of the start tool pocket when the reset function is used for tool magazine 1.	1	1 - 100	P						
341	Tool magazine 2 total tool No.	Sets the number of tool stations of tool magazine 2 (in response to the mechanical differences of tool magazines, you need to set the number of the placeable tools with this parameter).	10	2 - 255	P						
342	Tool magazine 2 standby tool No. after reset	Sets the standby tool pocket number when the reset function is used for tool magazine 2.	1	1 - 100	P						
343	Tool magazine 2 start tool No.	Sets the tool number of the start tool pocket when the reset function is used for tool magazine 2.	1	1 - 100	P						
2012	1st DMCNET servo magazine	Supported station numbers are 10 to 12.	0	0 - 65535	P						

Parameter No.	Item	Description	Default value	Setting range	Note
2013	2nd DMCNET servo magazine	Supported station numbers are 10 to 12.	0	0 - 65535	P
2014	3rd DMCNET servo magazine	Supported station numbers are 10 to 12.	0	0 - 65535	P

12



## 12.4 Spindle parameter (SPINDLE)

Spindle parameters are for setting various spindle functions, such as spindle gain, spindle maximum speed, and spindle positioning tolerance.

### 12.4.1 Spindle parameter descriptions

Parameter No.	Item	Description	Default value	Setting range	Note																						
37	Spindle voltage output offset	Calibrates the spindle voltage output. When the inverter is Servo On and the spindle is stopped by the controller, if the spindle is still rotating, set this parameter to adjust the voltage output to have the spindle to come to a stop. Unit: 0.001V	0	-1000 to +1000	R																						
398	Spindle default speed	Spindle default speed.	0	0 - 60000	P																						
399	Spindle application setting	<table border="1"> <thead> <tr> <th>Function</th> <th>Range</th> </tr> </thead> <tbody> <tr> <td>Spindle function 0: disable spindle 1: enable spindle</td> <td>0 - 1</td> </tr> <tr> <td>Closed-loop control flag 0: off 1: enable closed-loop control (must have feedback encoder attached)</td> <td>0 - 1</td> </tr> <tr> <td>Spindle output mode 0: communication (DMCNET) 1: pulse 2: analog</td> <td>0 - 2</td> </tr> <tr> <td>Speed control mode 0: reserved 1: PPM (DMCNET)</td> <td>1</td> </tr> <tr> <td>Spindle encoder magnification 0: 1000 times 1: 4 times</td> <td>0 - 1</td> </tr> <tr> <td>Analog spindle speed source 0: command 1: encoder</td> <td>0 - 1</td> </tr> <tr> <td>Analog spindle feedback encoder source 0: spindle 1: motor</td> <td>0 - 1</td> </tr> <tr> <td>Spindle speed reference 0: program 1: Pr398</td> <td>0 - 1</td> </tr> <tr> <td>Spindle Max. speed command check 0: off 1: on</td> <td>0 - 1</td> </tr> <tr> <td>Spindle speed D1380 display mode 0: S code; S code command speed 1: Real-time; spindle real-time command speed</td> <td>0 - 1</td> </tr> </tbody> </table>	Function	Range	Spindle function 0: disable spindle 1: enable spindle	0 - 1	Closed-loop control flag 0: off 1: enable closed-loop control (must have feedback encoder attached)	0 - 1	Spindle output mode 0: communication (DMCNET) 1: pulse 2: analog	0 - 2	Speed control mode 0: reserved 1: PPM (DMCNET)	1	Spindle encoder magnification 0: 1000 times 1: 4 times	0 - 1	Analog spindle speed source 0: command 1: encoder	0 - 1	Analog spindle feedback encoder source 0: spindle 1: motor	0 - 1	Spindle speed reference 0: program 1: Pr398	0 - 1	Spindle Max. speed command check 0: off 1: on	0 - 1	Spindle speed D1380 display mode 0: S code; S code command speed 1: Real-time; spindle real-time command speed	0 - 1	0	0 - 0xFFFF	P
		Function	Range																								
		Spindle function 0: disable spindle 1: enable spindle	0 - 1																								
		Closed-loop control flag 0: off 1: enable closed-loop control (must have feedback encoder attached)	0 - 1																								
		Spindle output mode 0: communication (DMCNET) 1: pulse 2: analog	0 - 2																								
		Speed control mode 0: reserved 1: PPM (DMCNET)	1																								
		Spindle encoder magnification 0: 1000 times 1: 4 times	0 - 1																								
		Analog spindle speed source 0: command 1: encoder	0 - 1																								
		Analog spindle feedback encoder source 0: spindle 1: motor	0 - 1																								
		Spindle speed reference 0: program 1: Pr398	0 - 1																								
		Spindle Max. speed command check 0: off 1: on	0 - 1																								
Spindle speed D1380 display mode 0: S code; S code command speed 1: Real-time; spindle real-time command speed	0 - 1																										

Parameter No.	Item	Description	Default value	Setting range	Note
		Spindle voltage output mode (only effective in open loop control) 0: -10V to +10V 1: 0V to +10V	0 - 1		
		Multi-stage spindle feedback encoder switch 0: off 1: on	0 - 1		
401	Spindle encoder port No.	Set spindle encoder port No.	8	0 - 8	P
402	Spindle encoder resolution	Sets the spindle encoder resolution (single-phase). Unit: pulse/rev	1280	2 - 60000	P
403	Spindle integral gain	Sets the speed integral gain. The greater the value, the faster the response. But if the gain is too large, it may cause machine jitter. Unit: 0.001 rad/s	50	1 - 5000	P
404	Spindle high positioning speed	Sets the maximum speed for spindle positioning. If the current speed exceeds the setting of Pr404, the system decreases the spindle speed to the speed set in Pr404 and then performs spindle positioning. In addition, if the spindle speed is lower than the setting of Pr404, it refers to Pr420 Spindle low positioning speed. Unit: rpm	100	1 - 20000	P
405	Spindle positioning offset	Sets the Z-phase offset for servo spindle positioning. Unit: 0.01 degree	0	0 - 36000	R
406	Spindle target speed tolerance	Sets the allowable tolerance between the target speed and actual speed of the spindle. Unit: rpm	10	0 - 300	P
407	Spindle positioning tolerance	Sets the spindle positioning tolerance. If the actual positioning tolerance exceeds the setting, spindle positioning will be determined to be incomplete, and M2258 is not triggered. Unit: 0.01 degree	100	0 - 36000	P
408	Spindle zero speed tolerance	If the spindle speed is within the tolerance range, the zero speed signal is on. (NC > MLC M2257)	5	0 - 1000	P
409	Spindle maximum speed	Sets the maximum speed for spindle. Unit: rpm	20000	0 - 600000	P
411	Spindle ACC/DEC time constant	Sets the acceleration and deceleration time for the spindle. The greater the value, the longer the acceleration and deceleration time. Unit: msec	20	1 - 20000	R
412	Spindle S-curve time constant	Sets the S-curve time constant of the spindle. Unit: msec	10	1 - 2000	R
413	Spindle 2nd Kpp gain	Switch M1127 to instantly change the spindle Kpp gain. Set M1127 to On and the spindle Kpp gain refers to Pr413. Set M1127 to Off and the spindle Kpp gain refers to Pr419.	1	1 - 1000	R
416	Tapping ACC/DEC time constant	Sets the acceleration and deceleration time of the spindle when it performs tapping. Unit: msec	2000	1 - 20000	R
417	Tapping S-curve time constant	Sets the S-curve time constant of the spindle when it performs tapping. Unit: msec	100	1 - 2000	R

Parameter No.	Item	Description	Default value	Setting range	Note						
418	Spindle feedforward gain	The greater the gain, the less the following error. However, if the value is set too high, it may make the control command less smooth and cause machinery vibration.	0	0 - 200	R						
419	Spindle Kpp gain	When the spindle is under closed-loop voltage control, use this parameter to adjust the spindle position loop bandwidth. The greater the gain, the more precise the positioning. However, if the value is set too high, it may cause vibration. The parameter value is relevant to the bandwidth of the inverter. It is recommended that you start from a lower gain and then gradually increase the value.	0	0 - 1000	R						
420	Spindle low positioning speed	If the current spindle speed is slower than the setting of Pr404 or is zero, when the system performs spindle positioning, it refers to the speed set by this parameter. Unit: rpm	100	1 - 20000	R						
421	Tapping retraction speed ratio	Tapping retraction setting. The tapping retraction speed is tapping F value multiplied by the ratio of Pr421 tapping retraction speed; the higher the ratio, the faster the retraction speed. The ratio range is 1 - 5 times. Unit: 0.1 times	10	10 - 50	R						
422	Gear ratio numerator 1	Sets the spindle gear ratio numerator (speed in first gear).	1	0 - 60000	P						
423	Gear ratio denominator 1	Sets the spindle gear ratio denominator (speed in first gear).	1	0 - 60000	P						
424	Gear ratio numerator 2	Sets the spindle gear ratio numerator (speed in second gear).	1	0 - 60000	P						
425	Gear ratio denominator 2	Sets the spindle gear ratio denominator (speed in second gear).	1	0 - 60000	P						
426	Gear ratio numerator 3	Sets the spindle gear ratio numerator (speed in third gear).	1	0 - 60000	P						
427	Gear ratio denominator 3	Sets the spindle gear ratio denominator (speed in third gear).	1	0 - 60000	P						
428	Gear ratio numerator 4	Sets the spindle gear ratio numerator (speed in fourth gear).	1	0 - 60000	P						
429	Gear ratio denominator 4	Sets the spindle gear ratio denominator (speed in fourth gear).	1	0 - 60000	P						
436	First spindle speed error check time	If the difference between the command speed and feedback speed of the first spindle is greater than Pr406, and continually exceeds the spindle speed error check time (msec) set by Pr436, an alarm will sound (B30A spindle rotation speed error too large), and the feed axis and spindle will stop operating. When the parameter Pr436 is set as 0, the spindle rotation speed reached check will not be performed	0	0 - 65535	R						
437	Spindle auxiliary function	<table border="1"> <thead> <tr> <th>Function</th> <th>Range</th> </tr> </thead> <tbody> <tr> <td>Proximity switch positioning turn: when using the positioning function of proximity switch, use this parameter to set the number of rotations during Z-phase searching.</td> <td>0 - 3</td> </tr> <tr> <td>Spindle target speed tolerance unit switching: 0: the unit of Pr406 spindle target speed tolerance is rpm 1: the unit of Pr406 spindle target speed tolerance is per thousand (0.1%)</td> <td>0 - 1</td> </tr> </tbody> </table>	Function	Range	Proximity switch positioning turn: when using the positioning function of proximity switch, use this parameter to set the number of rotations during Z-phase searching.	0 - 3	Spindle target speed tolerance unit switching: 0: the unit of Pr406 spindle target speed tolerance is rpm 1: the unit of Pr406 spindle target speed tolerance is per thousand (0.1%)	0 - 1	0	0 - 3	P
		Function	Range								
Proximity switch positioning turn: when using the positioning function of proximity switch, use this parameter to set the number of rotations during Z-phase searching.	0 - 3										
Spindle target speed tolerance unit switching: 0: the unit of Pr406 spindle target speed tolerance is rpm 1: the unit of Pr406 spindle target speed tolerance is per thousand (0.1%)	0 - 1										

Parameter No.	Item	Description	Default value	Setting range	Note																						
438	2nd spindle default speed	The default spindle speed when power is on.	0	0 - 60000	P																						
439	2nd spindle application setting	<table border="1"> <thead> <tr> <th>Function</th> <th>Range</th> </tr> </thead> <tbody> <tr> <td>Spindle function 0: Disable spindle 1: Enable spindle</td> <td>0 - 1</td> </tr> <tr> <td>Closed-loop control flag 0: off 1: on (feedback encoder is required)</td> <td>0 - 1</td> </tr> <tr> <td>Spindle output mode 0: Communication (DMCNET) 1: reserved 2: Analog</td> <td>0 - 2</td> </tr> <tr> <td>Speed control mode 0: Reserved 1: PPM (DMCNET)</td> <td>1 - 1</td> </tr> <tr> <td>Spindle encoder magnification 0: 1000 times 1: 4 times</td> <td>0 - 1</td> </tr> <tr> <td>Analog spindle speed source 0: command 1: encoder</td> <td>0 - 1</td> </tr> <tr> <td>Analog spindle feedback encoder source 0: spindle 1: motor</td> <td>0 - 1</td> </tr> <tr> <td>Spindle speed reference 0: program 1: Pr398</td> <td>0 - 1</td> </tr> <tr> <td>Spindle Max. speed command check 0: off 1: on</td> <td>0 - 1</td> </tr> <tr> <td>Spindle speed D1380 display mode 0: command speed (S-code) 1: feedback</td> <td>0 - 1</td> </tr> </tbody> </table>	Function	Range	Spindle function 0: Disable spindle 1: Enable spindle	0 - 1	Closed-loop control flag 0: off 1: on (feedback encoder is required)	0 - 1	Spindle output mode 0: Communication (DMCNET) 1: reserved 2: Analog	0 - 2	Speed control mode 0: Reserved 1: PPM (DMCNET)	1 - 1	Spindle encoder magnification 0: 1000 times 1: 4 times	0 - 1	Analog spindle speed source 0: command 1: encoder	0 - 1	Analog spindle feedback encoder source 0: spindle 1: motor	0 - 1	Spindle speed reference 0: program 1: Pr398	0 - 1	Spindle Max. speed command check 0: off 1: on	0 - 1	Spindle speed D1380 display mode 0: command speed (S-code) 1: feedback	0 - 1	0	0 - 0xFFFF	P
Function	Range																										
Spindle function 0: Disable spindle 1: Enable spindle	0 - 1																										
Closed-loop control flag 0: off 1: on (feedback encoder is required)	0 - 1																										
Spindle output mode 0: Communication (DMCNET) 1: reserved 2: Analog	0 - 2																										
Speed control mode 0: Reserved 1: PPM (DMCNET)	1 - 1																										
Spindle encoder magnification 0: 1000 times 1: 4 times	0 - 1																										
Analog spindle speed source 0: command 1: encoder	0 - 1																										
Analog spindle feedback encoder source 0: spindle 1: motor	0 - 1																										
Spindle speed reference 0: program 1: Pr398	0 - 1																										
Spindle Max. speed command check 0: off 1: on	0 - 1																										
Spindle speed D1380 display mode 0: command speed (S-code) 1: feedback	0 - 1																										
441	2nd spindle encoder port No.	Sets the feedback channel of spindle encoder.	8	0 - 8	P																						
442	2nd spindle encoder resolution	Sets the encoder resolution (single-phase). Unit: pulse/rev	1280	2 - 60000	P																						
443	2nd spindle integral gain	Sets the speed integral gain. The greater the value, the faster the response. But if the gain is too large, it may cause machine jitter. Unit: 0.001 rad/s	50	1 - 1000	P																						
444	2nd spindle high positioning speed	Sets the maximum speed for spindle positioning. If the current speed exceeds the setting of Pr444, the system decreases the spindle speed to the speed set in Pr444 and then performs spindle positioning. In addition, if the spindle speed is lower than the setting of Pr444, it refers to Pr460 Spindle low positioning speed. Unit: rpm	100	1 - 20000	P																						
445	2nd spindle positioning offset	Sets the Z-phase offset for servo spindle positioning. Unit: 0.01 degree	0	0 - 36000	R																						

Parameter No.	Item	Description	Default value	Setting range	Note
446	2nd spindle target speed tolerance	Sets the allowable tolerance between the target speed and actual speed of the spindle. Unit: rpm	10	0 - 300	P
447	2nd spindle positioning tolerance	Sets the spindle positioning tolerance. If the actual positioning tolerance exceeds the setting, spindle positioning will be determined to be incomplete, and M2258 is not triggered. Unit: 0.01 degree	100	0 - 36000	P
448	2nd spindle zero speed tolerance	If the spindle speed is within the tolerance range, the zero speed signal is on. (NC > MLC M2257)	5	0 - 1000	P
449	2nd spindle maximum speed	Sets the maximum speed for spindle. Unit: rpm	20000	0 - 600000	P
450	2nd spindle minimum speed	Sets the minimum speed for spindle. Unit: rpm	10	0 - 10000	P
451	Second spindle ACC/DEC Time constant	Sets the acceleration and deceleration time for the spindle. The greater the value, the longer the acceleration and deceleration time. Unit: msec	20	1 - 20000	R
452	Second spindle S-curve Time constant	Sets the S-curve time constant of the spindle. Unit: msec	10	1 - 2000	R
453	2nd spindle 2nd Kpp gain	Switch M1127 to instantly change the spindle Kpp gain. Set M1127 to On and the spindle Kpp gain refers to Pr413; set M1127 to Off and the spindle Kpp gain refers to Pr419.	0	1 - 1000	R
456	2nd spindle tapping ACC/DEC time constant	Sets the acceleration and deceleration time of the spindle when it performs tapping. Unit: msec	2000	1 - 20000	R
457	Second spindle TAP S-curve time constant	Sets the S-curve time constant of the spindle when it performs tapping. Unit: msec	100	1 - 2000	R
458	2nd spindle feedforward gain	The greater the gain, the less the following error. However, if the value is set too high, it may make the control command less smooth and cause machinery vibration.	0	0 - 200	R
459	2nd spindle Kpp gain	When the spindle is under closed-loop voltage control, use this parameter to adjust the spindle position loop bandwidth. The greater the gain, the more precise the positioning. However, if the value is set too high, it may cause vibration. The parameter value is relevant to the bandwidth of the inverter. It is recommended that you start from a lower gain and then gradually increase the value.	0	0 - 1000	R
460	2nd spindle low positioning speed	If the current spindle speed is slower than the setting of Pr404 or is zero, when the system performs spindle positioning, it refers to the speed set by this parameter. Unit: rpm	100	1 - 20000	P
461	2nd spindle tapping retraction speed ratio	Tapping retraction setting. The tapping retraction speed is tapping F value multiplied by the ratio of Pr421 tapping retraction speed; the higher the ratio, the faster the retraction speed. The ratio range is 1 - 5 times. Unit: 0.1 times	10	10 - 50	R

Parameter No.	Item	Description	Default value	Setting range	Note
462	2nd spindle gear ratio numerator 1	Sets the 2nd spindle gear ratio numerator (speed in first gear).	1	0 - 60000	P
463	2nd spindle gear ratio denominator 1	Sets the 2nd spindle gear ratio denominator (speed in first gear).	1	0 - 60000	P
464	2nd spindle gear ratio numerator 2	Sets the 2nd spindle gear ratio numerator (speed in second gear).	1	0 - 60000	P
465	2nd spindle gear ratio denominator 2	Sets the 2nd spindle gear ratio denominator (speed in second gear).	1	0 - 60000	P
466	2nd spindle gear ratio numerator 3	Sets the 2nd spindle gear ratio numerator (speed in third gear).	1	0 - 60000	P
467	2nd spindle gear ratio denominator 3	Sets the 2nd spindle gear ratio denominator (speed in third gear).	1	0 - 60000	P
468	2nd spindle gear ratio numerator 4	Sets the 2nd spindle gear ratio numerator (speed in fourth gear).	1	0 - 60000	P
469	2nd spindle gear ratio denominator 4	Sets the 2nd spindle gear ratio denominator (speed in fourth gear).	1	0 - 60000	P
476	Second spindle speed error check time	If the difference between the command speed and feedback speed of the second spindle is greater than the setting of Pr446 and the duration exceeds the check time (msec) set in Pr476, an alarm occurs (B30A spindle rotation speed error too large). Meanwhile, the feed axis and spindle stop operating. When the parameter Pr476 is set to 0, the system does not check if the spindle rotation speed is reached.	0	0 - 65535	R
477	Second spindle auxiliary function	Spindle target speed tolerance unit switching: 0: The unit of Pr446 spindle target speed tolerance is rpm 1: The unit of Pr446 spindle target speed tolerance is per thousand (0.1%)	0	0 - 3	P
512	Spindle feedback speed filter time	This system will filter the spindle feedback signal (ms) with the following restrictions: ■ Setting value = 0: performs spindle feedback filtering with the filter time of 4 ms. ■ Setting value > 0 and < 200: use the set value to perform filtering. ■ Setting value > 200: perform spindle feedback speed filtering with the filter time of 200 ms.	0	0 - 65535	R

## 12.5 Machine parameter (MACHINE)

Supports related parameter settings of the machine equipment; they can be set in the machine parameter function page. Parameters such as software / hardware limits, lead screw pitch or encoder pulse number etc.

### 12.5.1 Machine parameter descriptions

Parameter No.	Item	Description	Default value	Setting range	Note
602	1st software positive limit	Sets the machine coordinates for the 1st software positive limit. When set as 0, this function is disabled. Unit: mm 1. Overtravel will cause software positive limit error. 2. Special M can be used to control ignore positive limit check.	10 <sup>5</sup>	-10 <sup>5</sup> to +10 <sup>5</sup>	R
603	1st software negative limit	Sets the machine coordinates for the 1st software negative limit. When set as 0, this function is disabled. Unit: mm 1. Overtravel will cause software negative limit error. 2. Special M can be used to control ignore negative limit check.	-10 <sup>5</sup>	-10 <sup>5</sup> to +10 <sup>5</sup>	R
604	2nd software positive limit	Sets the machine coordinates for the 2nd software positive limit. When set as 0, this function is disabled. Overtravel will cause software positive limit error. Unit: mm	10 <sup>5</sup>	-10 <sup>5</sup> to +10 <sup>5</sup>	R
605	2nd software negative limit	Sets the machine coordinates for the 2nd software negative limit. When set as 0, this function is disabled. Overtravel will cause software negative limit error. Unit: mm	-10 <sup>5</sup>	-10 <sup>5</sup> to +10 <sup>5</sup>	R
611	Stroke protection border 1	First border of stroke protection. This parameter must be used with Pr612 to form the protection range for the axis. You must set the border values for the X, Y and Z axes altogether to form a three-dimensional rectangular cube. If you set the same value or 0 for both Pr611 and Pr612, the restricted zone is invalid. The check switch for this parameter is Pr51 (Stroke protection).	0	-10 <sup>5</sup> to +10 <sup>5</sup>	R
612	Stroke protection border 2	Second border of stroke protection. This parameter must be used with Pr611 to form the protection range for the axis. You must set the border values for the X, Y and Z axes altogether to form a three-dimensional rectangular cube. If you set the same value or 0 for both Pr611 and Pr612, the restricted zone is invalid. The check switch for this parameter is Pr51 (Stroke protection).	0	-10 <sup>5</sup> to +10 <sup>5</sup>	R
627	Decimals of lead screw pitch	Set Pr634 [Bit 9] to 1 to enable the function of decimal places of lead screw pitch. After the function is enabled, the lead screw pitch for the axis is: Pr633 + Pr627 x 0.0001 (mm). Unit: 0.1 μm	0	0 – 9999	P

Parameter No.	Item	Description	Default value	Setting range	Note	
628	Sensor setting	Sets the input polarity of positive / negative hardware limits and the home sensor. When set as 0, the input works as a normally closed switch. When set as 1, the input works as a normally open switch.	0	0 - 3F	P	
		Function				Range
		Positive limit sensor setting				0 - 1
		Negative limit sensor setting				0 - 1
		Home sensor setting	0 - 1			
630	Encoder resolution	Sets the motor resolution per revolution (single-phase).	1280	10 - 50000	P	
631	Shaft gear number	Sets the gear number of the shaft. For example, the motor decelerates when you set Pr631 to 10 and Pr632 to 1. (The number of revolutions of the motor and spindle are 10 and 1 respectively, so the deceleration ratio is 10:1.) Set both Pr631 and Pr632 to 1 if there is no need to accelerate or decelerate.	1	1 - 65535	P	
632	Motor gear number	Sets the gear number for the motor. Refer to the example of Pr631.	1	1 - 65535	P	
633	Lead screw pitch	Sets the lead screw pitch for the drive shaft. The setting is only available for linear axes (X, Y, and Z axes) or when you set the linear axis as the rotation axis. Unit: mm	10	2 - 100	P	
634	Axis control variables	Function	Range	5	0 - 65535	P
		Scale up (this parameter must be used with the G50 command) 0: off 1: on	0 - 1			
		Rotation axis feed (available for A, B, and C axes but not for X, Y, and Z axes) 0: set as a rotation axis in non-shortest path mode. 1: set as a rotation axis in shortest path mode 2: set as a rotation axis with the display format of linear axis. 5: set as linear axis mode.	0 - 5			
		Encoder magnification 0: 1000 times 1: 4 times	0 - 1			
		Rotation axis unit (available for Pr618, Pr619, Pr620, Pr621, and Pr625) 0: rpm 1: deg/min	0 - 1			
		Decimal places of lead screw pitch 0: off 1: on	0 - 1			
MPG reverse motion 0: the coordinate moves in the positive direction when the MPG rotates in the positive direction 1: the coordinate moves in the negative direction when the MPG rotates in the negative direction	0 - 1					



## 12.6 Homing parameter (HOME)

Homing parameters are for setting the home search mode and the machine coordinates for the machine home, and the 2nd, 3rd, and 4th reference points.

### 12.6.1 Homing parameter descriptions

Parameter No.	Item	Description	Default value	Setting range	Note
606	Machine origin coordinate	Sets the distance from machine home sensor to Z-phase. The Z phase position is the machine origin coordinates. Unit: CU	0	-10 <sup>5</sup> to +10 <sup>5</sup>	R
607	2nd reference coordinate	Sets the machine coordinates for the 2nd reference point (for setting the position of G30) Unit: CU	0	-10 <sup>5</sup> to +10 <sup>5</sup>	P
608	3rd reference coordinate	Sets the machine coordinates for the 3rd reference point. Unit: CU	0	-10 <sup>5</sup> to +10 <sup>5</sup>	P
609	4th reference coordinate	Sets the machine coordinates for the 4th reference point. Unit: CU	0	-10 <sup>5</sup> to +10 <sup>5</sup>	P
610	Reference position tolerance	Sets the position tolerance for the 2nd reference point. For example, when set as 0.2, it means when the position error is within the ±0.2 mm range, they are all regarded as reaching the 2nd reference point.	0	-10 <sup>8</sup> to +10 <sup>8</sup>	P
613	Synchronous calibration value	The execution of homing is based on the parameter setting and fine-tune the position of the slave axis. The setting method is as follows: 1. Enable the slave axis parameter Pr617 synchronous calibration function, and confirm that the home parameters of the master and slave axes are consistent. 2. After confirming there are no errors with the machine positions of the mater and slave axes, set the synchronous function (M1088). 3. HMI operation sequence: DGN > system monitoring > synchronous monitoring 4. When synchronous calibration is set as 1, perform the operation for the synchronous calibration value and then wirt the result to Pr613 (Synchronous calibration value). Note: The Pr617 synchronous calibration function must be enabled to have the synchronous calibration field. 5. Cycle the power and execute homing to perform the calibration.	0	-2147483647 to +2147483647	P

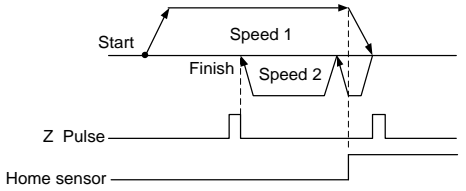
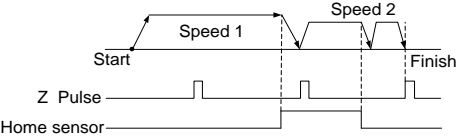
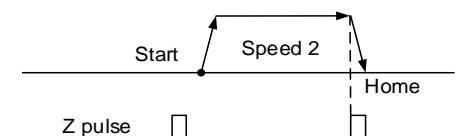
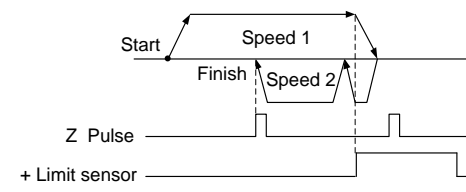
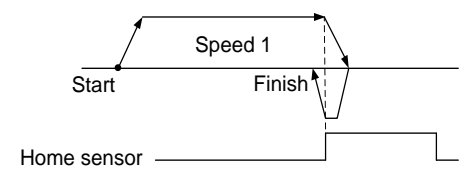
Parameter No.	Item	Description	Default value	Setting range	Note
616	Origin search mode	<p>0: sets the current position as the origin                      1: mode 1                      When homing, once the motor reaches the home sensor, it reverses and the system regards the first Z pulse as the origin.</p>  <p>2: Mode 2                      When homing, after the motor reaches the home sensor, it carries on in the same direction to leave the home sensor, and the system regards the first Z pulse as the origin.</p>  <p>3: Mode 3                      The motor looks for the Z pulse at the 2nd homing speed (Pr619) and the system regards it as the home.</p>  <p>4: mode 4 (OT mode)                      When homing, the system regards the positive limit as the home sensor. When the positive limit is triggered, the motor reverses and the system regards the first Z pulse as the home.</p>  <p>5: Mode 5                      Absolute motor.</p> <p>6: Mode 6                      Once the limit switch reaches the Home dog, it moves away, reverses and decelerates to a stop, and the stop point is regarded as the origin.</p> 	1	0 - 17	P

12

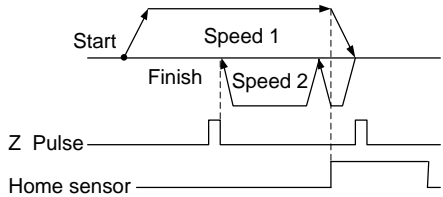
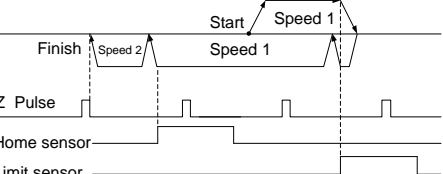
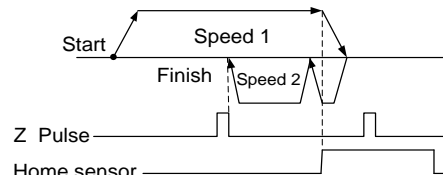
Parameter No.	Item	Description	Default value	Setting range	Note
616	Origin search mode	<p>7: Mode 7 (the function is exclusive to Renishaw's Biss C type single-coil absolute motors)</p> <p>After the servo performs homing for the absolute motor, if the system triggers the special M relays for homing (M1236 - M1241), the system will complete the return home action immediately and will not clear the machine coordinates.</p> <p>8: Mode 8</p> <p>There are two possible conditions when homing. One is that the motor first reaches the home sensor and the other is that the motor first reaches the limit sensor.</p> <p>Condition 1: the motor first reaches the home sensor and reverses to find the Z pulse.</p>  <p>Condition 2: the motor first reaches the limit sensor and reverses to find the home sensor, and then carries on in the same direction to find the Z pulse.</p> 	1	0 - 17	P
		<p>24: Mode 24</p> <p>When the mechanism is equipped with home sensor and uses absolute motor, the use of this mode is recommended.</p> <p>First, use the return home action of Mode 4 to search for home, and then use the absolute reset function on the DGN page. After absolute reset, cycle power to the system. The homing mode is automatically switched to mode 5 after power cycling.</p> 	1	0 - 17	P

Parameter No.	Item	Description		Default value	Setting range	Note
		Function	Range			
617	Origin search setting	Homing search direction 0: Reverse 1: positive	0 - 1	1	0 - 31	P
		Search the blocks when homing 0:Off 1: on	0 - 1			
		Homing mode of rotation axis 0: single-turn After the system calculates the parity angle, it will only move the remaining angle distance. 1: absolute The system will fully return to home according to the distance before returning home. And will not perform parity angle processing.	0 - 1			
		Return mode after reaching home sensor 0: return to the machine origin After finding the Z pulse, the axis offsets by the value set in Pr606. Then, the system regards the current position as the machine origin, completing the homing procedure. 1: return to the Z pulse After finding the Z pulse, the servo no longer moves, completing the homing procedure.	0 - 1			
		Homing option for sync. motion: 0: when the synchronous control function is enabled, the slave axes and the master axis return to the origin synchronously. 1: When the synchronous control function is enabled, each axis can return to the origin individually with the synchronous protection function (Pr642) remains enabled.	0 - 1			

Parameter No.	Item	Description	Default value	Setting range	Note
		<p>Ignore Z-phase distance</p> <p>0:Off After leaving the block stop, the first Z-phase found will be used as the reference Z-phase for homing.</p> <p>1: on After leaving the block stop and went over it by a fixed distance, the first Z-phase found will be used as the reference Z-phase for homing; the fixed distance is set through parameter Pr645.</p>	0 - 1		
		<p>Synchronous calibration function</p> <p>0:Off 1: on The execution of return home is based on parameter setting and fine-tuning the slave axis position, and the Pr613 synchronous calibration value must be referred to. The calibration function for the slave axis must be enabled in this parameter. After confirming there are no errors with the machine position of the master and slave axes, enable and calculate the difference (Pr613 synchronous calibration value) between the Z-phase of the master and slave axes from the synchronous related page on HMI, so that when homing is executed the next time, the slave axis can correct its position according to the current difference in Z-phase between the master and slave axes, as well as Pr613.</p>	0 - 1		
618	1st homing speed	Sets the speed for searching home sensor. Unit: mm/min	2000	0 - 10000	R
619	2nd homing speed	Sets the speed for searching the Z pulse. Unit: mm/min	200	0 - 2000	R
620	Speed for moving to reference point	Sets the speed for the first homing after booting with Pr618 and Pr619. After the system completes homing, the speed value of Pr620 will be used for future homing. Unit: mm/min	10	0 - 20000	R
624	Homing origin protection distance	Sets the allowable distance that the motor moves away from the Home block when searching for the home block. If the moving distance exceeds the setting, an alarm occurs. Unit: mm	20	1 - 2000	R

Parameter No.	Item	Description	Default value	Setting range	Note
645	Ignore Z-phase distance	<p>Linear axis: when the motor leaves the protector, it looks for the next Z phase by going for the distance over pitch x PR645 (%). If the next Z phase is within the distance (pitch x Pr645(%)), the motor skips this Z phase and then goes further to look for the next one.</p> <p>Rotation axis: when the motor leaves the protector, it looks for the next Z phase by going for the distance over Pr645% x 360 degrees. If the nearest Z phase is within the distance of Pr645% x 360 degrees, it skips this Z phase and then goes further to look for the next one.</p>	100	0% - 100%	R

## 12.7 Ethernet setting (ETH.)

You can use Ethernet to connect the system to the PC to enable remote communication. Using the CNCNetwork software and the network setting of NC series controller can manage the online files of multiple NC controllers with one PC, enabling data sharing and file management with the PC, and transmission-along-with-machining (DNC).

### 12.7.1 Ethernet parameter descriptions

Parameter No.	Item	Description	Default value	Setting range	Note								
10030	Host name	System's host name.	CNC000	1 - 8	R								
10031	IP address	Sets the system IP address.	0.0.0.0	0 - 255	P								
10032	Subnet mask	Sets the subnet mask of the system.	0.0.0.0	0 - 255	P								
10033	Default gateway	Sets the system default gateway.	0.0.0.0	0 - 255	P								
10034	Network function	Sets the network function of the system.	0	0 - 1	P								
		<table border="1"> <thead> <tr> <th>Function</th> <th>Range</th> </tr> </thead> <tbody> <tr> <td>Enable remote network functions 0: off 1: on</td> <td>0 - 1</td> </tr> <tr> <td>Remote PC IP restriction 0: Specify When set to 0, it will check whether the remote PC IP really exists in Pr10036 - Pr10040. 1: Domain When set to 1, PC equipment in the same CNC domain can connect to CNC directly.</td> <td>0 - 1</td> </tr> </tbody> </table>				Function	Range	Enable remote network functions 0: off 1: on	0 - 1	Remote PC IP restriction 0: Specify When set to 0, it will check whether the remote PC IP really exists in Pr10036 - Pr10040. 1: Domain When set to 1, PC equipment in the same CNC domain can connect to CNC directly.	0 - 1		
Function	Range												
Enable remote network functions 0: off 1: on	0 - 1												
Remote PC IP restriction 0: Specify When set to 0, it will check whether the remote PC IP really exists in Pr10036 - Pr10040. 1: Domain When set to 1, PC equipment in the same CNC domain can connect to CNC directly.	0 - 1												
10035	DHCP switch	Enable the DHCP function. 0: off 1: on	0	0 - 1	P								
10036	Remote PC IP address 1	IP address 1	0	255	P								
10037	Remote PC IP address 2	IP address 2	0	255	P								
10038	Remote PC IP address 3	IP address 3	0	255	P								
10039	Remote PC IP address 4	IP address 4	0	255	P								
10040	Remote PC IP address 5	IP address 5	0	255	P								
10041	Shared remote directory IP address	The PC IP address specified in Program > NETWORK in EDIT mode. 0: do not specify an IP address.	0	0 - 5	P								
10055	FTP setting	<table border="1"> <thead> <tr> <th>Function</th> <th>Range</th> </tr> </thead> <tbody> <tr> <td>FTP function switch</td> <td>0 - 1</td> </tr> <tr> <td>FTP anonymous login</td> <td>0 - 1</td> </tr> <tr> <td>Switch to main file after file upload</td> <td>0 - 1</td> </tr> </tbody> </table>	Function	Range	FTP function switch	0 - 1	FTP anonymous login	0 - 1	Switch to main file after file upload	0 - 1	0	0 - 11	P
		Function	Range										
		FTP function switch	0 - 1										
		FTP anonymous login	0 - 1										
Switch to main file after file upload	0 - 1												
0: off; 1: on													

Parameter No.	Item	Description	Default value	Setting range	Note
10058	FTP password	Sets the password with 1 - 6 characters.	123456	-	P
10078	FTP username	Sets the username with 1 - 6 characters.	123456	-	P

12



## 12.8 Compensation parameter (COMP)

During the operation of machine tool, differences of mechanism may lead to motion error, and thus cause minor error in the machining results. Set the relevant compensation parameters to have the controller compute the appropriate compensation amount according to the machine characteristics. The operation steps are as follows.

- (1) Press **PAR** to enter the PAR screen.
- (2) Press **▶** to display the function bar on the second page.
- (3) Press **COMP** to enter the compensation parameter setting screen.
- (4) Press **↑** and **↓** to move the cursor to the specified field, and enter a value within the range specified in the lower right corner of the screen. As shown in Figure 12.8.1.
- (5) Press **ENTER** to complete the setting.
- (6) The data field to enter the length compensation can be entered using the **um** function key, which is an absolute value input of um. Or enter use the **um+** function key, which is an incremental input of um.
- (7) Use the CNCSoft to convert the compensation data measured by the calibration equipment into compensation parameter files. Then, press **IMPORT** on the function bar in the next page to import the data in absolute format. You can also press **IMPORT+** to import the data and add the data to the existing values.
- (8) Press **OK** to confirm the update.

Compensation		DEFAULT	NC	HL	SFT
No.	Parameter Name	X	Y	Z	
1000	Backlash compensation amount	R 0.00200	0.00200	0.00300	
1001	Backlash compensation time	R 100	100	100	
1002	Backlash compensation delay time	R 100	100	100	
1003	Friction compensation amount	R 0.00000	0.00000	0.00000	
1004	Friction compensation time	R 0	0	0	
1005	Friction compensation delay time	R 0	0	0	
1006	Thread pitch compensation setting	R 0	0	0	
	• Absolute or increment input (0: Abs; 1: Inc)	0	0	0	
	• Friction compensation in positive direction	0	0	0	
	• Friction compensation in negative direction	0	0	0	
	• Friction compensation mode	0	0	0	
	• Measuring direction (0: positive; 1: negative)	0	0	0	
	• Bi-directional thread pitch compensation	0	0	0	
1007	Measuring point number	R 14	17	17	
1008	Measuring interval	R 60.00000	30.00000	30.00000	
Range: -2 ~ 2 (mm, inch)					
AUTO		Ch 0		1/19	
↑	OK		um	um+	▶

Figure 12.8.1

### 12.8.1 Compensation parameter descriptions

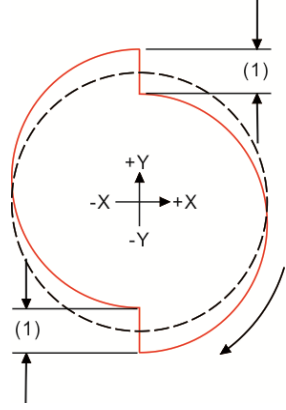
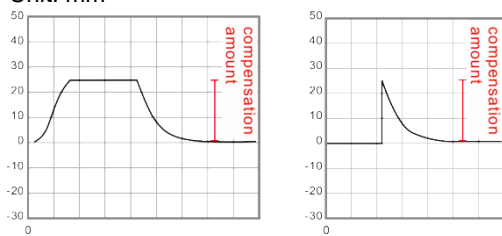
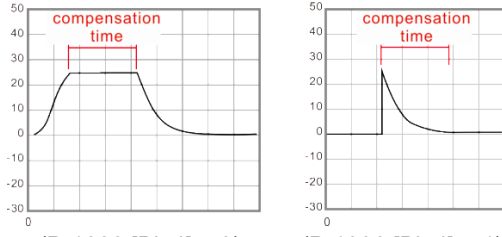
Parameter No.	Item	Description	Default value	Setting range	Note
1000	Backlash compensation amount	<p>There is backlash in the lead pitch for most of the mechanical systems. Set this parameter with a positive value to compensate for backlash in positive direction, and vice versa. Set this parameter to 0 to disable the backlash compensation function. Unit: mm, inch</p>  <p>(1) Backlash in Y axis</p>	0	-2 to +2	R
1001	Backlash compensation time	<p>Sets the time constant of backlash compensation. When the backlash compensation time is 0, the backlash compensation function is disabled. Unit: 0.1 msec</p>	0	0 - 10000	R
1002	Backlash compensation delay time	<p>Sets the delay time for enabling the backlash compensation function. Unit: 0.1 msec</p>	0	0 - 10000	R
1003	Friction compensation amount	<p>Sets the friction compensation amount. Unit: mm</p>  <p>(Pr1006 [Bit 4] = 0) (Pr1006 [Bit 4] = 1)</p>	0	0 - 1	R
1004	Friction compensation time	<p>Sets the friction compensation time. Unit: 0.1 msec</p>  <p>(Pr1006 [Bit 4] = 0) (Pr1006 [Bit 4] = 1)</p>	0	0 - 10000	R

12

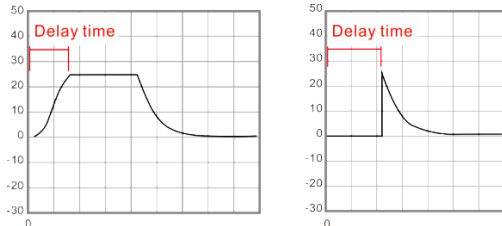
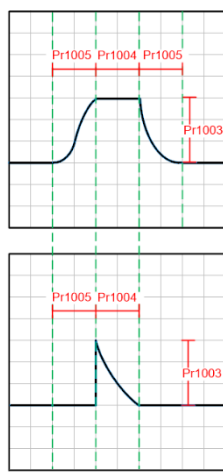
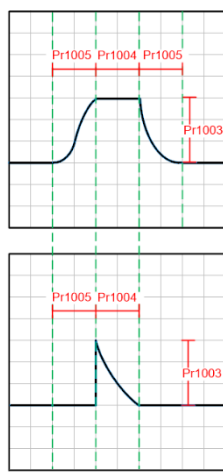
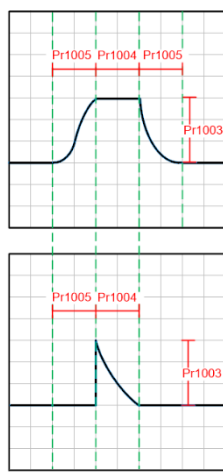
Parameter No.	Item	Description	Default value	Setting range	Note														
1005	Friction compensation delay time	<p>Sets the friction compensation delay time. Unit: 0.1 msec</p>  <p>(Pr1006 [Bit 4] = 0)      (Pr1006 [Bit 4] = 1)</p>	0	0 - 10000	R														
1006	Thread pitch compensation setting	<table border="1"> <thead> <tr> <th>Function</th> <th>Range</th> </tr> </thead> <tbody> <tr> <td>                     Absolute or incremental input.                      0: absolute input (actual value of the measuring point)                      1: incremental input (the difference of the current and previous measuring points)                 </td> <td>0 - 1</td> </tr> <tr> <td>                     Friction compensation in positive direction.                      Timing: compensates when the machine moves in positive direction                      0: Off                      1: on                 </td> <td>0 - 1</td> </tr> <tr> <td>                     Friction compensation in negative direction.                      Timing: compensates when the machine moves in reverse direction                      0: Off                      1: on                 </td> <td>0 - 1</td> </tr> <tr> <td>                     Friction compensation mode                      0: pulse width type   </td> <td>0 - 1</td> </tr> <tr> <td>                     Measuring direction (of the start point)                      0: positive direction from machine coordinates                      1: negative direction from machine coordinates                 </td> <td>0 - 1</td> </tr> <tr> <td>                     Bi-directional thread pitch compensation                      0: Off                      1: on                 </td> <td>0 - 1</td> </tr> </tbody> </table>	Function	Range	Absolute or incremental input. 0: absolute input (actual value of the measuring point) 1: incremental input (the difference of the current and previous measuring points)	0 - 1	Friction compensation in positive direction. Timing: compensates when the machine moves in positive direction 0: Off 1: on	0 - 1	Friction compensation in negative direction. Timing: compensates when the machine moves in reverse direction 0: Off 1: on	0 - 1	Friction compensation mode 0: pulse width type 	0 - 1	Measuring direction (of the start point) 0: positive direction from machine coordinates 1: negative direction from machine coordinates	0 - 1	Bi-directional thread pitch compensation 0: Off 1: on	0 - 1	0	0 - 0xFFFF	R
Function	Range																		
Absolute or incremental input. 0: absolute input (actual value of the measuring point) 1: incremental input (the difference of the current and previous measuring points)	0 - 1																		
Friction compensation in positive direction. Timing: compensates when the machine moves in positive direction 0: Off 1: on	0 - 1																		
Friction compensation in negative direction. Timing: compensates when the machine moves in reverse direction 0: Off 1: on	0 - 1																		
Friction compensation mode 0: pulse width type 	0 - 1																		
Measuring direction (of the start point) 0: positive direction from machine coordinates 1: negative direction from machine coordinates	0 - 1																		
Bi-directional thread pitch compensation 0: Off 1: on	0 - 1																		

Parameter No.	Item	Description	Default value	Setting range	Note
1007	Measuring point number	Sets the number of the measuring points for the lead screw pitch compensation with the maximum as 128. Set this parameter to 0 to disable the compensation function.	0	0 - 128	R
1008	Measuring interval	Sets the interval between each measuring point on the lead screw. Unit: mm	0	0 - 300	R
1009	Measuring offset	Sets the offset between the measuring point and machine origin. For example, when you set this parameter to 0, there will be no offset from home; when you set this parameter to 10mm, there will be an offset of 10 mm from home. Note: The direction of the offset should be identical to the direction specified in Pr1006 [Bit 15].	0	-1000 to +1000	R
1010 - 1137	Data 1 - Data 128	Sets the lead screw pitch compensation for the 1 <sup>st</sup> to 128 <sup>th</sup> points. The 1st point and the origin should be the same point. Unit: mm (linear axes), deg (rotation axes)	0	-20 to +20	R
1138 - 1265	Reverse data 1 - Reverse data 128	Sets the lead screw pitch compensation in negative direction for the 1 <sup>st</sup> to 128 <sup>th</sup> points. Enable Pr1006 Bi-directional thread pitch compensation to have this parameter group take effect. Unit: mm (linear axes), deg (rotation axes)	0	-20 to +20	R

## 12.9 System parameter (SYSTEM)

In the system parameter setting screen, you can change the settings of the system's working environment. Items include the system date, system time, background color, function bar text color, and label text color. You can set each of these items individually as required.

### 12.9.1 System parameter descriptions

Parameter No.	Item	Description	Default value	Setting range	Note	
10000	System date	Sets the system date (format: yyyy/mm/dd).	-	-	-	
10001	System time	Sets the system time (format: hh:mm:ss).	-	-	-	
10003	Screen brightness	Sets the screen brightness.	50	1 - 99	-	
10004	User-defined language	Set this parameter to change the language of the software screens. The setting range varies according to the number of languages set by the user. Note: The B series systems must use this parameter to change the language.	0	0 - 1	-	
10005	External device setting	Function	Range	256	256 - 36708	R
		Mouse sensitivity	0 - 100			
		HID mouse format 0: off 1: on	0 - 1			
		Automatically enable keyboard NumLock 0: off 1: on	0 - 1			
		Cursor display time (second)	1 - 15			
		Enable touch IO 0: off 1: on Note: When the screen component is triggered, M1153 will remain ON for a short period of time. This function is usually used to trigger the buzzer when the screen is touched.	0 - 1			
		Keyboard pop-up mode 0: double-click 1: single click	0 - 1			
		Enable USB panel B 0: off 1: on Note: This function requires a dedicated external USB adapter.	0 - 1			
10007	Initial macro program	Execute the macro program specified by this parameter before pressing <b>CYCLE START</b> . Note: This program has to be stored in the O_Macro folder and the naming method is O+Pr10007.	0	0 - 9999	P	
10008	System length unit	Sets the unit system for length display on the NC system. 0: metric 1: imperial	0	0 - 1	P	

Parameter No.	Item	Description	Default value	Setting range	Note														
10009	Sync coordinate setting	Sets the display of the synchronous coordinates.	0	0 - 65535	-														
		<table border="1"> <thead> <tr> <th>Function</th> <th>Range</th> </tr> </thead> <tbody> <tr> <td>Sync coordinate display 0: off 1: on</td> <td>0 - 1</td> </tr> <tr> <td>Sync workpiece coordinate display 0: off 1: on</td> <td>0 - 1</td> </tr> </tbody> </table>				Function	Range	Sync coordinate display 0: off 1: on	0 - 1	Sync workpiece coordinate display 0: off 1: on	0 - 1								
		Function				Range													
Sync coordinate display 0: off 1: on	0 - 1																		
Sync workpiece coordinate display 0: off 1: on	0 - 1																		
10010	Screensaver	Enable the screensaver. 0: off 1: on	0	0 - 1	-														
10011	Screensaver time 1	Sets the first wait time for the screensaver.	10	1 - 60	-														
10012	Screen brightness 1	Sets the first level of brightness for the screensaver.	30	0 - 99	-														
10013	Screensaver time 2	Sets the second wait time for the screensaver.	30	1 - 60	-														
10014	Screen brightness 2	Sets the second level of brightness for the screensaver.	10	0 - 99	-														
10015	Account setting	<table border="1"> <thead> <tr> <th>Function</th> <th>Range</th> </tr> </thead> <tbody> <tr> <td>Account permission activation method 0: enabled by system 1: enabled by external I/O M2934 = 1 (lock) M2934 = 0 (unlock)</td> <td>0 - 1</td> </tr> <tr> <td>Automatically opens the last file: After enabling this function, when you insert the USB drive or CF card to the controller, the system automatically opens the last executed file. 0: off 1: on</td> <td>0 - 1</td> </tr> <tr> <td>Open auxiliary input window: this function should be used with the mouse. With the mouse connected to the system, when you click the upper right corner, a list appears; when you click the input window, a keyboard appears. 0: off 1: on</td> <td>0 - 1</td> </tr> <tr> <td>Machining count display format 0: W; Word 1: DW; Double Word</td> <td>0 - 1</td> </tr> <tr> <td>Prohibit the showing of pop-up windows 0: display pop-up windows 1: hide pop-up windows</td> <td>0 - 1</td> </tr> <tr> <td>Disables the function of automatically diving values with no decimal points by a thousand 0: divide by a thousand. The number entered on the OFS screen will be automatically divided by 1000 1: do not divide by a thousand. The number entered on the OFS screen will not be divided by 1000 automatically</td> <td>0 - 1</td> </tr> </tbody> </table>	Function	Range	Account permission activation method 0: enabled by system 1: enabled by external I/O M2934 = 1 (lock) M2934 = 0 (unlock)	0 - 1	Automatically opens the last file: After enabling this function, when you insert the USB drive or CF card to the controller, the system automatically opens the last executed file. 0: off 1: on	0 - 1	Open auxiliary input window: this function should be used with the mouse. With the mouse connected to the system, when you click the upper right corner, a list appears; when you click the input window, a keyboard appears. 0: off 1: on	0 - 1	Machining count display format 0: W; Word 1: DW; Double Word	0 - 1	Prohibit the showing of pop-up windows 0: display pop-up windows 1: hide pop-up windows	0 - 1	Disables the function of automatically diving values with no decimal points by a thousand 0: divide by a thousand. The number entered on the OFS screen will be automatically divided by 1000 1: do not divide by a thousand. The number entered on the OFS screen will not be divided by 1000 automatically	0 - 1	0	0 - 65535	P
		Function	Range																
		Account permission activation method 0: enabled by system 1: enabled by external I/O M2934 = 1 (lock) M2934 = 0 (unlock)	0 - 1																
		Automatically opens the last file: After enabling this function, when you insert the USB drive or CF card to the controller, the system automatically opens the last executed file. 0: off 1: on	0 - 1																
		Open auxiliary input window: this function should be used with the mouse. With the mouse connected to the system, when you click the upper right corner, a list appears; when you click the input window, a keyboard appears. 0: off 1: on	0 - 1																
		Machining count display format 0: W; Word 1: DW; Double Word	0 - 1																
Prohibit the showing of pop-up windows 0: display pop-up windows 1: hide pop-up windows	0 - 1																		
Disables the function of automatically diving values with no decimal points by a thousand 0: divide by a thousand. The number entered on the OFS screen will be automatically divided by 1000 1: do not divide by a thousand. The number entered on the OFS screen will not be divided by 1000 automatically	0 - 1																		

12

Parameter No.	Item	Description		Default value	Setting range	Note
		Function	Range			
10016	System setting	Reset system after EMG release (Reset): sets whether to automatically generate a Reset signal after the emergency stop is released. 0: off 1: on	0 - 1	4	0 - 65535	P
		[SOFT] display after bootup: Sets whether to display the SOFT screen as the default screen after system bootup. 0: off 1: switch to SOFT screen after bootup	0 - 1			
		Display alarm screen when alarm occurs 0: do not show pop-up alarm screen 1: show pop-up alarm screen when alarms occur	0 - 1			
		Enable automatic backup of system parameters: When this function is enabled, the system automatically makes a backup of the parameter data and stores it to the CF card. Once any of the parameters is modified, the backup data in the CF card is updated as well. 0: disable 1: on	0 - 1			
		Hidden axis coordinates setting: If you disable one axis in the CONFIG screen, set this parameter to display or hide the corresponding axis coordinate. 0: display; display the hidden axis coordinates 1: Hide; hide the hidden axis coordinates	0 - 1			
		O macro file protection: Once this function is enabled, you can only copy the O macro files to the internal memory rather than copy the files from the internal memory to external devices. 0: disable file protection 1: enable file protection	0 - 1			
		Extension variable display 0: 450 1: 1000	0 - 1			
		Writing of parameters is prohibited 0: allow writing 1: prohibit writing	0 - 1			

Parameter No.	Item	Description	Default value	Setting range	Note
		[POS] group screen display 0: enable 1: disable Note: this parameter is only applicable to the A series models.	0 - 1		
		[PRG] group screen display 0: enable 1: disable Note: this parameter is only applicable to the A series models	0 - 1		
		[OFS] group screen display 0: enable 1: disable Note: this parameter is only applicable to the A series models	0 - 1		
		[DGN] group screen display 0: enable 1: disable	0 - 1		
		[ALM] group screen display 0: enable 1: disable Note: this parameter is only applicable to the A series models	0 - 1		
		[GRA] group screen display 0: enable 1: disable Note: this parameter is only applicable to the A series models	0 - 1		
		[PAR] group screen display 0: Enable 1: Disable Note: this parameter is only applicable to the A series models	0 - 1		
		[SOFT] group screen display 0: Enable 1: Disable Note: this parameter is only applicable to the A series models	0 - 1		
10017	G-code edit setting	<b>Function</b>	<b>Range</b>	1	0 - 65535
		G code editing: sets whether to allow G code editing. 0: off 1: on	0 - 1		
		Macro call file source 0: CF card 1: internal memory	0 - 1		
		SF speed setting: Sets whether you can use the <b>SF SET</b> function to set the cutting feed rate. 0: off 1: on	0 - 1		
		Program resets automatically after editing: Sets whether the cursor will automatically return to the starting line position of the	0 - 1		



Parameter No.	Item	Description	Default value	Setting range	Note	
		program when switched from EDIT mode to any other operation modes. 0: off 1: on				
		Subprogram call file source 0: program 1: USB				0 - 1
		Subroutine file name display: After this parameter is enabled, when run to this subroutine, it sets whether the G code main file name will be displayed. 0: enable 1: disable				0 - 1
		.txt file support 0: off 1: on				0 - 1
		Friction compensation measurement program path: After the friction compensation function generates processes, the location where the process files are saved. 0: CF 1: O_MACRO				0 - 1
		System macro command functions 0: off 1: on				0 - 1
10018	Background color	Sets the background color.	LIGHTGRAY	0 - 65535	-	
10019	Title bar text color	Sets the text color for the title bar.	BLACK	0 - 65535	-	
10020	Mode bar text color	Sets the text color for the mode bar.	DARKBLUE	0 - 65535	-	
10021	Function bar text color	Sets the text color for the function bar.	BLACK	0 - 65535	-	
10022	Label text color	Sets the text color for the labels.	BLACK	0 - 65535	-	
10023	Numeric value color	Sets the text color for numeric values.	BLUE	0 - 65535	-	
10024	Table gridline color	Sets the color of table gridline.	BLACK	0 - 65535	-	
10025	System cursor color	Sets the color of the cursor.	COLOR_S07	0 - 65535	-	
10026	System text highlight color	Sets the text highlight color.	WHITE	0 - 65535	-	
10027	Software panel cursor color	Sets the cursor color in the software panel.	YELLOW	0 - 65535	-	
10028	System alarm color	Sets the color of system alarms.	RED	0 - 65535	-	
10029	User-defined alarm color	Sets the color of user-defined alarms.	BLUE	0 - 65535	-	

Parameter No.	Item	Description	Default value	Setting range	Note																										
10042	Software panel text highlight color	Sets the text highlight color in the software panel.	COLOR_S07	0 - 65535	-																										
10043	[PAR] group item display	<table border="1"> <thead> <tr> <th>Function</th> <th>Range</th> </tr> </thead> <tbody> <tr> <td>[OPERATE] display 0: on; 1: off Note: this parameter is only applicable to the A series models.</td> <td>0 - 1</td> </tr> <tr> <td>[MAGA] display 0: on; 1: off Note: this parameter is only applicable to the A series models.</td> <td>0 - 1</td> </tr> <tr> <td>[SPINDLE] display 0: on; 1: off Note: this parameter is only applicable to the A series models.</td> <td>0 - 1</td> </tr> <tr> <td>[MACHINE] display 0: on; 1: off Note: this parameter is only applicable to the A series models.</td> <td>0 - 1</td> </tr> <tr> <td>[HOME] display 0: on; 1: off Note: this parameter is only applicable to the A series models.</td> <td>0 - 1</td> </tr> <tr> <td>[COMP] display 0: on; 1: off Note: this parameter is only applicable to the A series models.</td> <td>0 - 1</td> </tr> <tr> <td>[SYSTEM] display 0: on; 1: off Note: this parameter is only applicable to the A series models.</td> <td>0 - 1</td> </tr> <tr> <td>[MLC] display 0: on; 1: off Note: this parameter is only applicable to the A series models.</td> <td>0 - 1</td> </tr> <tr> <td>[GRAPHIC] display 0: on; 1: off Note: this parameter is only applicable to the A series models.</td> <td>0 - 1</td> </tr> <tr> <td>[SERVO] display 0: on; 1: off Note: this parameter is only applicable to the A series models.</td> <td>0 - 1</td> </tr> <tr> <td>[CONFIG] display 0: on; 1: off Note: this parameter is only applicable to the A series models.</td> <td>0 - 1</td> </tr> <tr> <td>[SET RIO] display 0: on; 1: off Note: this parameter is only applicable to the A series models.</td> <td>0 - 1</td> </tr> </tbody> </table>	Function	Range	[OPERATE] display 0: on; 1: off Note: this parameter is only applicable to the A series models.	0 - 1	[MAGA] display 0: on; 1: off Note: this parameter is only applicable to the A series models.	0 - 1	[SPINDLE] display 0: on; 1: off Note: this parameter is only applicable to the A series models.	0 - 1	[MACHINE] display 0: on; 1: off Note: this parameter is only applicable to the A series models.	0 - 1	[HOME] display 0: on; 1: off Note: this parameter is only applicable to the A series models.	0 - 1	[COMP] display 0: on; 1: off Note: this parameter is only applicable to the A series models.	0 - 1	[SYSTEM] display 0: on; 1: off Note: this parameter is only applicable to the A series models.	0 - 1	[MLC] display 0: on; 1: off Note: this parameter is only applicable to the A series models.	0 - 1	[GRAPHIC] display 0: on; 1: off Note: this parameter is only applicable to the A series models.	0 - 1	[SERVO] display 0: on; 1: off Note: this parameter is only applicable to the A series models.	0 - 1	[CONFIG] display 0: on; 1: off Note: this parameter is only applicable to the A series models.	0 - 1	[SET RIO] display 0: on; 1: off Note: this parameter is only applicable to the A series models.	0 - 1	0	0 - 65535	P
		Function	Range																												
		[OPERATE] display 0: on; 1: off Note: this parameter is only applicable to the A series models.	0 - 1																												
		[MAGA] display 0: on; 1: off Note: this parameter is only applicable to the A series models.	0 - 1																												
		[SPINDLE] display 0: on; 1: off Note: this parameter is only applicable to the A series models.	0 - 1																												
		[MACHINE] display 0: on; 1: off Note: this parameter is only applicable to the A series models.	0 - 1																												
		[HOME] display 0: on; 1: off Note: this parameter is only applicable to the A series models.	0 - 1																												
		[COMP] display 0: on; 1: off Note: this parameter is only applicable to the A series models.	0 - 1																												
		[SYSTEM] display 0: on; 1: off Note: this parameter is only applicable to the A series models.	0 - 1																												
		[MLC] display 0: on; 1: off Note: this parameter is only applicable to the A series models.	0 - 1																												
		[GRAPHIC] display 0: on; 1: off Note: this parameter is only applicable to the A series models.	0 - 1																												
		[SERVO] display 0: on; 1: off Note: this parameter is only applicable to the A series models.	0 - 1																												
		[CONFIG] display 0: on; 1: off Note: this parameter is only applicable to the A series models.	0 - 1																												
[SET RIO] display 0: on; 1: off Note: this parameter is only applicable to the A series models.	0 - 1																														

12

Parameter No.	Item	Description	Default value	Setting range	Note																						
10044	Channel 0 - teach setting	Enable the Teach function for the corresponding axis. After this parameter is enabled, in JOG or MPG mode, set this parameter to enable the Teach function of the PRG group.	0	0 - 65535	P																						
		<table border="1"> <thead> <tr> <th>Function</th> <th>Range</th> </tr> </thead> <tbody> <tr> <td>X axis teaching 0: off; 1: on</td> <td>0 - 1</td> </tr> <tr> <td>Y axis teaching 0: off; 1: on</td> <td>0 - 1</td> </tr> <tr> <td>Z axis teaching 0: off; 1: on</td> <td>0 - 1</td> </tr> <tr> <td>A axis teaching 0: off; 1: on</td> <td>0 - 1</td> </tr> <tr> <td>B axis teaching 0: off; 1: on</td> <td>0 - 1</td> </tr> <tr> <td>C axis teaching 0: off; 1: on</td> <td>0 - 1</td> </tr> <tr> <td>U axis teaching 0: off; 1: on</td> <td>0-1</td> </tr> <tr> <td>V axis teaching 0: off; 1: on</td> <td>0-1</td> </tr> <tr> <td>W axis teaching 0: off; 1: on</td> <td>0 - 1</td> </tr> <tr> <td>Teaching G-code format 0: moving axes; 1: all axes</td> <td>0 - 1</td> </tr> </tbody> </table>				Function	Range	X axis teaching 0: off; 1: on	0 - 1	Y axis teaching 0: off; 1: on	0 - 1	Z axis teaching 0: off; 1: on	0 - 1	A axis teaching 0: off; 1: on	0 - 1	B axis teaching 0: off; 1: on	0 - 1	C axis teaching 0: off; 1: on	0 - 1	U axis teaching 0: off; 1: on	0-1	V axis teaching 0: off; 1: on	0-1	W axis teaching 0: off; 1: on	0 - 1	Teaching G-code format 0: moving axes; 1: all axes	0 - 1
		Function				Range																					
		X axis teaching 0: off; 1: on				0 - 1																					
		Y axis teaching 0: off; 1: on				0 - 1																					
		Z axis teaching 0: off; 1: on				0 - 1																					
		A axis teaching 0: off; 1: on				0 - 1																					
		B axis teaching 0: off; 1: on				0 - 1																					
		C axis teaching 0: off; 1: on				0 - 1																					
		U axis teaching 0: off; 1: on				0-1																					
		V axis teaching 0: off; 1: on				0-1																					
		W axis teaching 0: off; 1: on				0 - 1																					
		Teaching G-code format 0: moving axes; 1: all axes				0 - 1																					
10045	[PRG]/[OFS]/ [DGN] group closed Display	<table border="1"> <thead> <tr> <th>Function</th> <th>Range</th> </tr> </thead> <tbody> <tr> <td>[TUNING] display 0: on; 1: off Note: this parameter is only applicable to the A series models.</td> <td>0 - 1</td> </tr> <tr> <td>[TEXT WR] display 0: on; 1: off Note: this parameter is only applicable to the A series models.</td> <td>0 - 1</td> </tr> <tr> <td>[LOGO WR] display 0: on; 1: off Note: this parameter is only applicable to the A series models.</td> <td>0 - 1</td> </tr> <tr> <td>[MACRO] display 0: on; 1: off Note: this parameter is only applicable to the A series models.</td> <td>0 - 1</td> </tr> <tr> <td>[FILE QUEUE] display 0: Display; 1: disable Note: this parameter is only applicable to the A series models.</td> <td>0 - 1</td> </tr> </tbody> </table>	Function	Range	[TUNING] display 0: on; 1: off Note: this parameter is only applicable to the A series models.	0 - 1	[TEXT WR] display 0: on; 1: off Note: this parameter is only applicable to the A series models.	0 - 1	[LOGO WR] display 0: on; 1: off Note: this parameter is only applicable to the A series models.	0 - 1	[MACRO] display 0: on; 1: off Note: this parameter is only applicable to the A series models.	0 - 1	[FILE QUEUE] display 0: Display; 1: disable Note: this parameter is only applicable to the A series models.	0 - 1	0	0 - 65535	P										
		Function	Range																								
		[TUNING] display 0: on; 1: off Note: this parameter is only applicable to the A series models.	0 - 1																								
		[TEXT WR] display 0: on; 1: off Note: this parameter is only applicable to the A series models.	0 - 1																								
		[LOGO WR] display 0: on; 1: off Note: this parameter is only applicable to the A series models.	0 - 1																								
[MACRO] display 0: on; 1: off Note: this parameter is only applicable to the A series models.	0 - 1																										
[FILE QUEUE] display 0: Display; 1: disable Note: this parameter is only applicable to the A series models.	0 - 1																										
10053	Barcode reading Related settings	<table border="1"> <thead> <tr> <th>Function</th> <th>Range</th> </tr> </thead> <tbody> <tr> <td>Barcode file reading 0: off; 1: file scan; 2: element</td> <td>0 - 2</td> </tr> <tr> <td>Trigger special M relay after reading barcode</td> <td>0 - 1023</td> </tr> <tr> <td>Barcode reading file source 0: CF card 1: internal memory</td> <td>0 - 1</td> </tr> <tr> <td>Barcode input mode 0: element; 1: system</td> <td>0 - 1</td> </tr> </tbody> </table>	Function	Range	Barcode file reading 0: off; 1: file scan; 2: element	0 - 2	Trigger special M relay after reading barcode	0 - 1023	Barcode reading file source 0: CF card 1: internal memory	0 - 1	Barcode input mode 0: element; 1: system	0 - 1	0	0 - 8190	P												
		Function	Range																								
		Barcode file reading 0: off; 1: file scan; 2: element	0 - 2																								
		Trigger special M relay after reading barcode	0 - 1023																								
Barcode reading file source 0: CF card 1: internal memory	0 - 1																										
Barcode input mode 0: element; 1: system	0 - 1																										

Parameter No.	Item	Description	Default value	Setting range	Note										
10054	Auto logout time	Sets the auto logout duration. Unit: min	0	0 - 1440	-										
10059	OFS input mode	0: Write the machine coordinates into the coordinates system 1: Write the machine coordinates with absolute coordinates as 0 into the coordinates system	0	0 - 1	-										
10061	Barcode setting	Set maximum reading length (0: maximum). This parameter is applied to the file scan function under AUTO mode; it allows users to decide whether to read the barcode character length.	0	0 - 63	P										
10063	System fixed main file settings	Sets specific NC process main files that the system always reads upon bootup. 0: off; 1: on Note: This parameter is for use with special CAD/CAM machines only.	0	0 - 1	P										
10076	File queue settings	<table border="1"> <thead> <tr> <th>Function</th> <th>Range</th> </tr> </thead> <tbody> <tr> <td>[Advanced mode] - Enable file queue function 0: off; 1: on</td> <td>0 - 1</td> </tr> <tr> <td>[Advanced mode] - Sort mode 0: disabled; 1: prefix; 2: suffix; 3: general; 4: numbering</td> <td>0 - 4</td> </tr> <tr> <td>[Advanced mode] - Delete completed files automatically 0: off; 1: on</td> <td>0 - 1</td> </tr> <tr> <td>[Standard mode] - Queue saving mode 0: Save; retain queue contents after power cycling. 1: Load automatically; retain queue contents after power cycling and load the program automatically. 2: Do not save; the queue is cleared after power interruption.</td> <td>0 - 2</td> </tr> </tbody> </table>	Function	Range	[Advanced mode] - Enable file queue function 0: off; 1: on	0 - 1	[Advanced mode] - Sort mode 0: disabled; 1: prefix; 2: suffix; 3: general; 4: numbering	0 - 4	[Advanced mode] - Delete completed files automatically 0: off; 1: on	0 - 1	[Standard mode] - Queue saving mode 0: Save; retain queue contents after power cycling. 1: Load automatically; retain queue contents after power cycling and load the program automatically. 2: Do not save; the queue is cleared after power interruption.	0 - 2	0	0 - 537	P
		Function	Range												
		[Advanced mode] - Enable file queue function 0: off; 1: on	0 - 1												
		[Advanced mode] - Sort mode 0: disabled; 1: prefix; 2: suffix; 3: general; 4: numbering	0 - 4												
		[Advanced mode] - Delete completed files automatically 0: off; 1: on	0 - 1												
[Standard mode] - Queue saving mode 0: Save; retain queue contents after power cycling. 1: Load automatically; retain queue contents after power cycling and load the program automatically. 2: Do not save; the queue is cleared after power interruption.	0 - 2														

## 12.10 MLC setting (MLC)

You can set parameters related to the MLC ladder, such as the displayed device and ladder color, in the MLC setting screen.

### 12.10.1 MLC parameter descriptions

Parameter No.	Item	Description	Default value	Setting range	Note
2000	MLC scanning time	After you set this parameter and enable the control flag (Pr2001), the system scans the MLC ladders with the set intervals (ms). The greater the value, the more delay in the update of the MLC device.	2	2 - 1000	P
2001	Control flag	MLC fixed scanning time 0: disable 1: enable (once enabled, there will be more process resource for the HMI)	0	0 - 1	P
2003	Local I/O Filter time	Sets the filter time for local I/O. Unit: msec	0	0 - 20	P
12000	Program title	Sets the program title.			-
12001	Company name	Enter the company name.	0		-
12002	Designer name	Enter the designer name.	0		-
12003	Show comment	Sets whether to show the comments. 0: off 1: on	0	0 - 1	-
12004	Show symbol	Sets whether to show the symbols. 0: off 1: on	0	0 - 1	-
12005	Ladder color	Sets the ladder color.	BLACK	0 - 65535	-
12006	Ladder text color.	Sets the text color for the ladder.	BLACK	0 - 65535	-
12007	Ladder symbol color	Sets the symbol color for the ladder.	BLACK	0 - 65535	-
12008	Ladder cursor color	Sets the cursor color for the ladder.	LIGHT BLUE	0 - 65535	-
12009	Ladder monitoring status display color	Sets the monitoring status display color for the ladder.	LIGHT GREEN	0 - 65535	-
12010	Ladder device comment color	Sets the comment color of the device for the ladder.	BROWN	0 - 65535	-
12011	Ladder segment comment color	Sets the comment color of the section for the ladder.	BROWN	0 - 65535	-
12012	Ladder row comment color	Sets the comment color of the ladder row.	BROWN	0 - 65535	-
12013	Ladder monitoring value color	Sets the color of the monitoring values for the ladder.	LIGHTRED	0 - 65535	-
12014	NC special device color	Sets the color of NC special devices.	COLOR_S2B	0 - 65535	-
12015	MLC special device color	Sets the color of MLC special devices.	MAGENTA	0 - 65535	-

Parameter No.	Item	Description		Default value	Setting range	Note
		Function	Range			
12016	MLC protection	MLC edit protection: when this function is enabled, you can only edit the MLC programs in EDIT mode. 0: off 1: on	0 - 1	1	0 - 65535	P
		MLC display 0: on 1: off	0 - 1			
		MLC auto backup: when this function is enabled, the system automatically makes a backup of the MLC data to the CF card. 0: off 1: on	0 - 1			
		EMG protection for MLC file saving: after this parameter is enabled, you need to press the emergency stop button if you need save the modifications on the MLC. 0: on 1: off	0 - 1			
		MLC file-saving reminder for group switch: When this parameter is enabled, if in MLC EDIT mode but the group screen is pressed, a file-saving reminder will pop-up. 0: off 1: on	0 - 1			
12017	MLC setting	Function	Range	0	0 - 65535	P
		Immediate take effect after MLC file load: when this function is enabled, MLC files take effect right after being loaded without restarting the system. 0: off 1: on	0 - 1			
		Record system data in special registers 0: off 1: on D1102: write main file name (O0000 - O9999) D1103, D1104: total machining time (sec.) D1105, D1106: single machining time (sec.) D1107: year, month D1108: day, hour D1109: minute, second Note: Set hexadecimal format to access D registers and then convert the data into decimal format for use. For example: 2020 February 28 PM06:45:59 D1107 = <u>14 02</u> 14(HEX) = 20(DEC) 2000+20 02(HEX) = 02(DEC)	0 - 1			

12

Parameter No.	Item	Description	Default value	Setting range	Note	
		D1108 = <u>1C</u> <u>12</u> 1C (HEX) = 28 (DEC) 12 (HEX) = 18 (DEC) D1109 = <u>2D</u> <u>3B</u> 2D (HEX) = 45 (DEC) 3B (HEX) = 59 (DEC)				
		Shortcuts for triggering M device 0: off 1: on	0 - 1			
		MLC user-defined keypad 0: off 1: on	0 - 1			
		MLC user-defined keypad function mode 0: Single point 1: Multi-point	0 - 1			
12019	[SPACE]+[POS] hot key for triggering M device	0: function disabled 1 - 3071: set devices M1 - M3071	0	0 - 3071	-	
12020	[SPACE]+[PRG] hot key for triggering M device	0: function disabled 1 - 3071: set devices M1 - M3071	0	0 - 3071	-	
12021	[SPACE]+[OFS] hot key for triggering M device	0: function disabled 1 - 3071: set devices M1 - M3071	0	0 - 3071	-	
12022	[SPACE]+[DGN] hot key for triggering M device	0: function disabled 1 - 3071: set devices M1 - M3071	0	0 - 3071	-	
12023	[SPACE]+[ALM] hot key for triggering M device	0: function disabled 1 - 3071: set devices M1 - M3071	0	0 - 3071	-	
12024	[SPACE]+[GRA] hot key for triggering M device	0: function disabled 1 - 3071: set devices M1 - M3071	0	0 - 3071	-	
12025	[SPACE]+[PAR] hot key for triggering M device	0: function disabled 1 - 3071: set devices M1 - M3071	0	0 - 3071	-	
12026	[SPACE]+[SOFT] hot key for triggering M device	0: function disabled 1 - 3071: set devices M1 - M3071	0	0 - 3071	-	
12027	Enable user alarm 0	Function	Range	0	0 - 65535	P
		Enable A0 - A15 alarms	0 - 1			
		Enable A16 - A31 alarms	0 - 1			
		Enable A32 - A47 alarms	0 - 1			
		Enable A48 - A63 alarms	0 - 1			
		Enable A64 - A79 alarms	0 - 1			
		Enable A80 - A95 alarms	0 - 1			
Enable A96 - A111 alarms	0 - 1					

Parameter No.	Item	Description	Default value	Setting range	Note	
		Enable A112 - A127 alarms	0 - 1			
		Enable A128 - A143 alarms	0 - 1			
		Enable A144 - A159 alarms	0 - 1			
		Enable A160 - A175 alarms	0 - 1			
		Enable A176 - A191 alarms	0 - 1			
		Enable A192 - A207 alarms	0 - 1			
		Enable A208 - A223 alarms	0 - 1			
		Enable A224 - A239 alarms	0 - 1			
		Enable A240 - A255 alarms	0 - 1			
12028	Enable user alarm trigger 1	Function	Range	0	0 - 65535	P
		Enable A256 - A271 alarms	0 - 1			
		Enable A272 - A287 alarms	0 - 1			
		Enable A288 - A303 alarms	0 - 1			
		Enable A304 - A319 alarms	0 - 1			
		Enable A320 - A335 alarms	0 - 1			
		Enable A336 - A351 alarms	0 - 1			
		Enable A352 - A367 alarms	0 - 1			
		Enable A368 - A383 alarms	0 - 1			
		Enable A384 - A399 alarms	0 - 1			
		Enable A400 - A415 alarms	0 - 1			
		Enable A416 - A431 alarms	0 - 1			
		Enable A432 - A447 alarms	0 - 1			
		Enable A448 - A463 alarms	0 - 1			
		Enable A464 - A479 alarms	0 - 1			
		Enable A480 - A495 alarms	0 - 1			
Enable A4960 - A511 alarms	0 - 1					
12029	System/ user-defined keyboard for switching M device	<ol style="list-style-type: none"> <li>1. If the status of this M device is On, the preset key combination function operations is disabled.</li> <li>2. If the status is Off, the preset key combination operations are allowed. This function is only effective when Pr12017 [MLC user-defined keyboard function] is 1.</li> </ol> <p>Note: this function is only available for OPENCNC.</p>	0	0 - 3071	-	
12030	Corresponding D device numbers for user-defined keyboard button values	<ol style="list-style-type: none"> <li>1. Writes the keyboard value received by the keyboard into the corresponding D register.</li> <li>2. After pressing the keyboard, the value is written to the D register; when the key is released, the value in the D register is cleared to 0.</li> </ol> <p>Note:</p> <ol style="list-style-type: none"> <li>1. This function is only effective when Pr12017 [MLC user-defined keyboard keypad] is 1.</li> <li>2. This function is only available for OPENCNC.</li> </ol>	0	0 - 1531	-	



## 12.11 Graph parameter (GRAPHIC)

You can set the graphic display of the motion trajectory in the GRA group with graph parameters.

### 12.11.1 Graph parameter descriptions

Parameter No.	Item	Description	Default value	Setting range	Note										
14000	Line color	Sets the line color.	BLACK	0 - 65535	-										
14001	Background color	Sets the background color.	SEA	0 - 65535	-										
14002	Graphic display setting	Sets the graphic display.	1	0 - 65535	-										
		<table border="1"> <thead> <tr> <th>Function</th> <th>Range</th> </tr> </thead> <tbody> <tr> <td>Line width</td> <td>0 - 4</td> </tr> <tr> <td>Enable auxiliary line display</td> <td>0 - 1</td> </tr> </tbody> </table>				Function	Range	Line width	0 - 4	Enable auxiliary line display	0 - 1				
		Function				Range									
Line width	0 - 4														
Enable auxiliary line display	0 - 1														
14003	Graphic setting	<table border="1"> <thead> <tr> <th>Function</th> <th>Range</th> </tr> </thead> <tbody> <tr> <td>Graphic default screen</td> <td>0 - 1</td> </tr> <tr> <td>X-Y plane display direction</td> <td>0 - 3</td> </tr> <tr> <td>Y-Z plane display direction</td> <td>0 - 3</td> </tr> <tr> <td>X-Z plane display direction</td> <td>0 - 3</td> </tr> </tbody> </table>	Function	Range	Graphic default screen	0 - 1	X-Y plane display direction	0 - 3	Y-Z plane display direction	0 - 3	X-Z plane display direction	0 - 3	0	0 - 65535	P
		Function	Range												
		Graphic default screen	0 - 1												
		X-Y plane display direction	0 - 3												
Y-Z plane display direction	0 - 3														
X-Z plane display direction	0 - 3														
<table border="1"> <tr> <td>0</td> <td>1</td> <td>2</td> <td>3</td> </tr> <tr> <td></td> <td></td> <td></td> <td></td> </tr> </table>	0	1	2	3											
0	1	2	3												
<table border="1"> <tr> <td>0</td> <td>1</td> <td>2</td> <td>3</td> </tr> <tr> <td></td> <td></td> <td></td> <td></td> </tr> </table>	0	1	2	3											
0	1	2	3												
<table border="1"> <tr> <td>0</td> <td>1</td> <td>2</td> <td>3</td> </tr> <tr> <td></td> <td></td> <td></td> <td></td> </tr> </table>	0	1	2	3											
0	1	2	3												
14004	X-Y plane graphic dimension	Sets the graphic dimension of the X-Y plane. Unit: mm	200	5 - 100000	-										
14005	Y-Z plane graphic dimension	Sets the graphic dimension of the Y-Z plane. Unit: mm	200	5 - 100000	-										
14006	X-Z plane graphic dimension	Sets the graphic dimension of the X-Z plane. Unit: mm	200	5 - 100000	-										
14007	X-Y-Z plane graphic dimension	Sets the graphic dimension of the X-Y-Z plane. Unit: mm	200	5 - 100000	-										
14008	Graphic setting	<table border="1"> <thead> <tr> <th>Function</th> <th>Range</th> </tr> </thead> <tbody> <tr> <td>Auto preview: When this function is enabled, when <b>AUTO mode</b> is pressed, CNC will quickly scan the NC content once, and calculate an appropriate GRA drawing range on the screen. 0: Do not run 1: Run</td> <td>0 - 1</td> </tr> <tr> <td>Run M30 and reserve graphics: When this function is enabled, the graphics are automatically reserved after M30 is executed. 0: off 1: on</td> <td>0 - 1</td> </tr> </tbody> </table>	Function	Range	Auto preview: When this function is enabled, when <b>AUTO mode</b> is pressed, CNC will quickly scan the NC content once, and calculate an appropriate GRA drawing range on the screen. 0: Do not run 1: Run	0 - 1	Run M30 and reserve graphics: When this function is enabled, the graphics are automatically reserved after M30 is executed. 0: off 1: on	0 - 1	0	0 - 65535	P				
		Function	Range												
Auto preview: When this function is enabled, when <b>AUTO mode</b> is pressed, CNC will quickly scan the NC content once, and calculate an appropriate GRA drawing range on the screen. 0: Do not run 1: Run	0 - 1														
Run M30 and reserve graphics: When this function is enabled, the graphics are automatically reserved after M30 is executed. 0: off 1: on	0 - 1														
14010	Grid color	Sets the grid color.	1	0 - 65535	-										
14011	Subgrid color	Sets the subgrid color.	1	0 - 65535	-										

Parameter No.	Item	Description	Default value	Setting range	Note
14012	Coordinate axis color	Sets the color of the coordinate axis.	1	0 - 65535	-
14013	Auxiliary line color	Sets the color of the auxiliary lines.	1	0 - 65535	-

12

## 12.12 Servo parameter (SERVO)

You can set the parameters for the servo drive in the servo parameter setting screen.

### 12.12.1 Servo parameter descriptions

Group	No.	Function	Description	Default value	Setting range	Note
P0	0	Firmware version	Displays the firmware version of the servo.	-	0	-
P1	1	Input for control mode and control command	Sets the control mode.	0	0x00 - 0x110F (HEX)	-
			<table border="1"> <thead> <tr> <th>Function</th> <th>Range</th> </tr> </thead> <tbody> <tr> <td>Torque output direction</td> <td>0 - 1</td> </tr> </tbody> </table>			
Function	Range					
Torque output direction	0 - 1					
P1	8	Position command smoothing constant	The low-pass filter for position command is usually used for eliminating undesired high-frequency response or noise and smoothing and commands. Unit: 10 msec	0	0	Applicable to CNC
P1	32	Motor stop mode function	Motor stop mode function.	0	0 - 20	-
P1	36	S-curve ACC/DEC constant	The low-pass filter for S-curve is usually used for eliminating undesired high-frequency response or noise and smoothing and commands. Unit: msec	0	0	Applicable to CNC
P1	37	Load inertia ratio	Load inertia ratio of servo motor. Unit: 0.1 times	10	0 - 2000	-
P1	44	E-gear ratio numerator (N1)	Multi-stage E-gear ratio numerator setting. Unit: pulse	1	1 - (2 <sup>29</sup> -1)	Read only
P1	45	E-gear ratio denominator (M1)	E-gear ratio denominator (M). Unit: pulse	1	1 - (2 <sup>31</sup> -1)	Read only
P1	52	Regeneration resistance value	Regeneration resistance value. Unit: ohm	With models	With models	-
P1	53	Regenerative capacity	Resistance capacity. Unit: Watt	With models	With models	-
P1	55	Maximum speed limit	Sets the maximum speed of the servo motor. The default is the rated speed. Unit: rpm	0	0 - 65535	-
P1	62	Percentage of friction compensation	Sets the level of friction compensation. Unit: %	0	0 - 100	-
P1	63	Constant of friction compensation (ms)	Sets the smoothing constant of friction compensation. Unit: ms	4	4	Applicable to CNC
P1	68	Position command Moving Filter	The moving filter smooths the beginning and end of the step command, but it also delays the command. Unit: ms	4	0 - 100	-
P2	0	Position control gain	Increasing the position control gain can enhance the position response and reduce the deviation in position control. If you set the value too high, it may cause vibration and noise. Unit: rad/s	35	0 - 2047	-
P2	1	Position control gain rate of change	Adjusts the rate of change for the position control gain according to the gain switching condition. This parameter is usually used for adjusting the gain of the feeding axis for it to be in accordance with that of the spindle when tapping. Unit: %	100	10 - 500	-

Group	No.	Function	Description	Default value	Setting range	Note
P2	2	Position feed forward gain	If the position control command changes position smoothly, increasing the gain value can reduce the position following errors. If it does not change smoothly, decreasing the gain value can reduce the mechanical vibration during operation. Unit: %	50	0 - 100	-
P2	3	Position feed forward gain smoothing constant	If the position control command changes position smoothly, decreasing the smoothing constant value can reduce the position following errors. If it does not change smoothly, increasing the smoothing constant value can reduce the mechanical vibration during operation. Unit: msec	5	2 - 100	-
P2	4	Speed control gain	Increasing the speed control gain can enhance the speed response. If you set the value too high, it may cause vibration and noise. Unit: rad/s	500	0 - 8191	-
P2	5	Speed control gain rate of change	Adjust the rate of change for the speed control gain according to the gain switching condition. Unit: %	100	10 - 500	-
P2	6	Speed integral compensation	Increasing the value of the integral speed control can enhance the speed response and reduce the deviation in speed control. If you set the value too high, it may cause vibration and noise. Unit: rad/s	100	0 - 1023	-
P2	7	Speed feed forward gain	If the speed control command changes speed smoothly, increasing the gain value can reduce the speed following errors. If it does not change smoothly, decreasing the gain value can reduce the mechanical vibration during operation. Unit: %	0	0 - 100	-
P2	9	DI response filter time	Digital input response filter time. Unit: 2 msec	2	0 - 20	-
P2	10	Digital input pin D11 Function planning	Digital input pin D11	-	-	-
P2	11	Digital input pin D12 Function planning	Digital input pin D12	-	-	-
P2	12	Digital input pin D13 Function planning	Digital input pin D13	-	-	-
P2	13	Digital input pin D14 Function planning	Digital input pin D14	-	-	-
P2	14	Digital input pin D15 Function planning	Digital input pin D15	-	-	-
P2	15	Digital input pin D16 Function planning	Digital input pin D16	-	-	-
P2	16	Digital input pin D17 Function planning	Digital input pin D17	-	-	-
P2	17	Digital input pin D18 Function planning	Digital input pin D18	-	-	-
P2	23	Notch filter frequency (1)	The first setting for mechanical resonance frequency. Unit: Hz	1000	50 - 1000	-
P2	24	Notch filter attenuation level (1)	The first set of resonance suppression notch filter attenuation level; the notch filter function is disabled if set to 0. Unit: dB	0	0 - 32	-

Group	No.	Function	Description	Default value	Setting range	Note
P2	25	Resonance suppression low-pass filter	Sets the time constant for the low-pass filter for resonance suppression. The low-pass filter is disabled if this parameter is set to 0. Unit: 0.1 msec	2	0 - 1000	-
P2	26	Anti-interference gain	Increasing this parameter can increase the damping of the speed loop. Setting the value of P2-26 to equal P2-06 is recommended. In Position mode, decrease the value of this parameter to reduce position overshoot. Unit: 0.001	0	0 - 0	Applicable to CNC
P2	27	Gain switching condition and method selection	When the signal of gain switching is on, the rate of change for the speed control gain is changed to the setting of P2-05.	0	0 - 4 (HEX)	-
P2	28	Gain switching time constant	Gain switching time constant. Unit: 10 msec	10	0 - 1000	-
P2	43	Notch filter frequency (2)	The second setting for mechanical resonance frequency. Unit: Hz	1000	50 - 2000	-
P2	44	Notch filter attenuation level (2)	The second set of resonance suppression notch filter attenuation level; the notch filter function is disabled if set to 0. Unit: dB	0	0 - 32	-
P2	45	Notch filter frequency (3)	The third setting for mechanical resonance frequency. Unit: Hz	1000	50 - 2000	-
P2	46	Notch filter attenuation level (3)	The third set of resonance suppression notch filter attenuation level; the notch filter function is disabled if set to 0. Unit: dB	0	0 - 32	-
P2	47	Auto resonance suppression mode	0: fixed 1: auto 2: continuous	1	0 - 2	-
P2	49	Speed detection filter and jitter suppression	Sets the filter for speed estimation. Unit: sec	0	0 - 1F	-
P2	52	Total stroke for indexing	Sets the total number of pulses required for one revolution of the rotation axis.			-
P2	53	Position integral compensation	When the position control integral value is increased, the position steady-state error reduces. Unit: rad/s	0	0 - 1023	-
P2	69	Absolute encoder	Sets the operation mode of the motor. 0: Incremental type 1: Absolute type	0	0 - 1	Cycle power to the servo
P3	12	CANopen / DMCNET support setting	CANopen / DMCNET support setting.	0	0 - 111	-
P4	0	Fault record (N)	The last abnormal status record.	0	-	Read only
P4	1	Fault record (N-1)	The second to last abnormal status record.	0	-	Read only
P4	2	Fault record (N-2)	The third to last abnormal status record.	0	-	Read only
P4	3	Fault record (N-3)	The fourth to last abnormal status record.	0	-	Read only
P4	4	Fault record (N-4)	The fifth to last abnormal status record.	0	-	Read only
P5	0	Firmware subversion	Displays the firmware subversion of the servo.	0	-	Read only

## 12.13 Channel setting (CONFIG)

You can enable the axes and define their attributes with this function as shown in Figure 12.13.1.

This function is not available in AUTO and MDI modes.

CONFIG		DEFAULT . NC					ML	SFT
Channel	Axis	Enable	NC	MLC	Port	Disp	Name	Used port
CH 0	X	<input checked="" type="checkbox"/>	<input checked="" type="checkbox"/>	<input type="checkbox"/>	1	<input checked="" type="checkbox"/>		1 <input checked="" type="checkbox"/> X
	Y	<input checked="" type="checkbox"/>	<input checked="" type="checkbox"/>	<input type="checkbox"/>	2	<input checked="" type="checkbox"/>		2 <input checked="" type="checkbox"/> Y
	Z	<input checked="" type="checkbox"/>	<input checked="" type="checkbox"/>	<input type="checkbox"/>	3	<input checked="" type="checkbox"/>		3 <input checked="" type="checkbox"/> Z
	A	<input type="checkbox"/>	<input type="checkbox"/>	<input type="checkbox"/>		<input type="checkbox"/>		4 <input checked="" type="checkbox"/> SP1
	B	<input type="checkbox"/>	<input type="checkbox"/>	<input type="checkbox"/>		<input type="checkbox"/>		5 <input type="checkbox"/>
	C	<input type="checkbox"/>	<input type="checkbox"/>	<input type="checkbox"/>		<input type="checkbox"/>		6 <input type="checkbox"/>
	U	<input type="checkbox"/>	<input type="checkbox"/>	<input type="checkbox"/>		<input type="checkbox"/>		7 <input type="checkbox"/>
	V	<input type="checkbox"/>	<input type="checkbox"/>	<input type="checkbox"/>		<input type="checkbox"/>		8 <input type="checkbox"/>
	W	<input type="checkbox"/>	<input type="checkbox"/>	<input type="checkbox"/>		<input type="checkbox"/>		9 <input type="checkbox"/>
	SP1	<input checked="" type="checkbox"/>	<input type="checkbox"/>	<input type="checkbox"/>	4	<input type="checkbox"/>		

JOG RPD 100% JOG 1000 s 100% Ready

OK

Figure 12.13.1

The operation steps are as follows.

- (1) Press the **PAR** key. Enters the PAR screen.
- (2) Press **▶** to display the function bar on the third page.
- (3) Press **CONFIG** to enter the channel setting screen.
- (4) Press **↑** and **↓** to move the cursor to the Enable field of the axis to be enabled, press **ENTER** to select the check box, which activates the setting of axial property. Set the axis as either the NC axis or the MLC axis.
- (5) Define the axis: Press **↑**, **↓**, **←**, and **→** to move the cursor to the specified field and **ENTER** to select the check box.
- (6) After defining the axis, press **↑**, **↓**, **←**, and **→** to move the cursor to the corresponding Port field. Press **ENTER** and a dialog box for port number input appears. Use **1** - **9** to enter a port number which is not the same as the set ones and then press **ENTER** to complete setting the port number.
- (7) After defining all the axes, press **OK**.
- (8) Restart the NC system.

Note:

1. To enable an axis, firstly select the check box of the corresponding Enable field. Then, you can set the axis as either an NC axis or MLC axis and set its port number which cannot be identical to other port numbers.
2. To disable an axis, move the cursor to the corresponding Enable field and press **ENTER** to cancel the selection. Then, the axis is disabled.

- When you change the value of the parameter with a P marked in the Parameter Name field, you have to restart the NC system to have the changed value take effect. When you change the value of the parameter without a P marked in the Parameter Name field, it takes effect immediately without restarting the NC system.

### 12.14 RIO setting

The NC system can add the control switches for external devices with the I/O extension modules. You can enable the I/O module in the RIO Setting screen As shown in Figure 12.14.1.

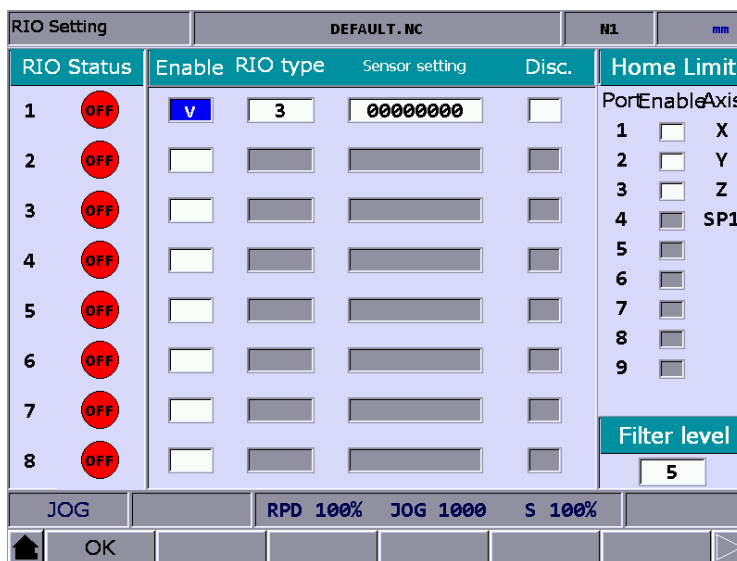

Figure 12.14.1

The operation steps are as follows.

- Press **PAR** to enter the Parameter (Group) screen.
- Press **▶** to display the function bar on the third page.
- Press **SET RIO** to enter the RIO Setting page.
- Press **↑** and **↓** to move the cursor to the corresponding Enable field of the specified RIO port, and press **ENTER** to select the check box and enable its corresponding settings.
- Press **←** and **→** to move the cursor to the Polarity setting field, press **ENTER**, and an input window appears. After entering the value, press **ENTER** to complete the setting.
- Press **←** and **→** to move the cursor to the Disc. field, and press **ENTER** to select or cancel the selection.
- After enabling and setting all the I/O modules, press **OK** to complete the setting.

### 12.14.1 Details of RIO setting

RIO: Press **OK** after completing the settings.

RIO Setting		DEFAULT.NC		N1	SFT
RIO Status	Enable	RIO type	Sensor setting	Disc.	Home Limit
1	<input checked="" type="checkbox"/>	3	00000000	<input type="checkbox"/>	PortEnableAxis
2	<input type="checkbox"/>				1 <input type="checkbox"/> X
3	<input type="checkbox"/>				2 <input type="checkbox"/> Y
4	<input type="checkbox"/>				3 <input type="checkbox"/> Z
5	<input type="checkbox"/>				4 <input type="checkbox"/> SP1
6	<input type="checkbox"/>				5 <input type="checkbox"/>
7	<input type="checkbox"/>				6 <input type="checkbox"/>
8	<input type="checkbox"/>				7 <input type="checkbox"/>
					8 <input type="checkbox"/>
					9 <input type="checkbox"/>
					Filter level
					2

JOG RPD 100% JOG 1000 S 100%

OK

- (1) Displays the connection status according to the connected RIO station number, starting with M2832 as Station 0.
- (2) Select the check box of the corresponding Enable field and set the RIO type to 3 as DIO; others include setting to 0 as AD/DA, 1 as DA, and 2 as AD.
- (3) DI input of the RIO can be set as the positive limit, negative limit, and home sensor of each axis, while only the DIs of Station 0 (the first RIO board) can be set. DIs on other RIO boards cannot be set. You can set 32 points in total from DI0 to DI31.
- (4) Select the Disc. Field to have the DO remain its status when it is disconnected from the controller.



Home Limit: press **OK** after completing the setting.

# 12

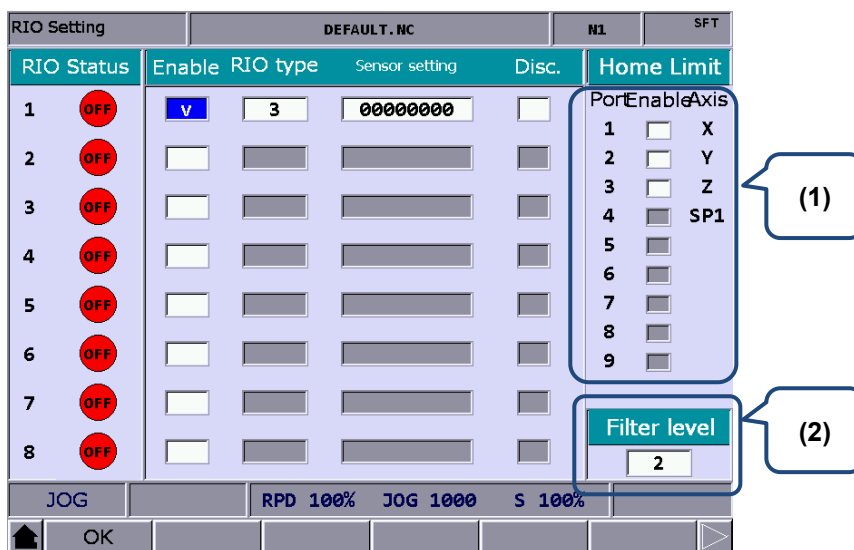

(1) Axis selection: the positive limit, negative limit, and home DI of X - A axes are inputted from axes port 1 - 4 of the controller. According to the selected axes, each axis takes three DI points from X256, which are positive limit DI, negative limit DI, and home limit DI respectively.

For example, if you select Y and Z axes, the positive limit, negative limit, and home limit for each axis are as shown in the following table.

Axis	X axis	Y axis	Z axis
Positive limit	AXIS_P1	X256	X259
Negative limit	AXIS_P2	X257	X260
Home	AXIS_P3	X258	X261

The special M relay code corresponding to the DI signal of each axis does not change regardless of the signal source.

Axis	X axis	Y axis	Z axis
Positive limit	M2144	M2148	M2152
Negative limit	M2145	M2149	M2153
Home	M2146	M2150	M2154

(2) Sets the filter level of the DI on the RIO board. The interval between each level is 40 ms and there are 5 levels in total.

Level 0	Level 1	Level 2	Level 3	Level 4	Level 5
200 μs	200 μs	400 μs	600 μs	800 μs	1 ms

### 12.14.2 Setting DA module (NC-EIO-DAC04)

The following steps illustrate how to set the DA module.

- (1) Enable Port 5 from the RIO setting page of the controller; only Ports 5 - 8 can be set for the DAC module.
- (2) Select 1 for the type, and D1464 - D1467 will correspond to the output points 0 - 3 of the module card respectively.
- (3) Rotate the station knob of the DAC module to 4.
- (4) Connect the DAC module to the controller in the same way as connecting the RIO.
- (5) After completing the three steps above, cycle power to the system. Then, set the value 1024 to D1464, and you can measure the voltage 1.25V at the output point 0 on the DA card (-/+10V correspond to -8191 to +8192).

Refer to the following table for the special D of MLC and the corresponding port number in the RIO Setting screen.

DAC / Port No.	5	6	7	8
Output point 0	D1464	D1472	D1480	D1488
Output point 1	D1465	D1473	D1481	D1489
Output point 2	D1466	D1474	D1482	D1490
Output point 3	D1467	D1475	D1483	D1491

# 12

## 12.15 Search (SEARCH)

The NC system includes many different types of parameters; therefore, users can use the search function and enter the parameter number to search for specific parameter fields. This function provides a quick and convenient way to display the parameter field screen for the specified parameter. The operation steps are as follows.

- (1) Press **PAR** to enter the Parameter (Group) screen.
- (2) Press **▶** to display the function bar on the third page.
- (3) Enter the parameter number to be searched to the input field in the lower left corner of the screen.
- (4) Press **SEARCH** to search for specific parameters.

Note: in addition to using the Search function, you can also search for the parameter in the PARAM GROUP screen by entering parameter numbers.

Searching method: enter "S" + "Parameter number", and then press **ENTER**.

## 12.16 Parameter group (PARAM GRP)

Various types of parameters are available in the NC system. Equipment distributors can use the parameter group function to provide users with the most appropriate combination of parameters according to industrial requirements for machining, which simplifies the complicated parameter adjustments, as shown in Figure 12.16.1.

PARAM GROUP		DEFAULT . NC		N1	SFT
No.	Parameter Name	GROUP1	GROUP2	GROUP3	GROUP4
311	Max. corner reference feedrate	0	1200	10000	15000
322	Cutting post S-curve time constant	1	3	20	10
309	Arc cutting reference feedrate	10	20	30	25
		Range: 0 ~ 50000 (mm/min)			
JOG		RPD 100%		JOG 1000 s 100%	
				Ready	
▲	SAVE	DEL PAR	DEL GRP	WRT PAR	RED PAR SRT PAR ▶

Figure 12.16.1

The operation steps are as follows.

- (1) Press **PAR** to enter the Parameter (Group) screen.
- (2) Press **▶** to display the function bar on the third page.
- (3) Press **PAR GRP** to enter the parameter group setting page.

- (4) Enter the specified parameter number in the No. field and press **ENTER** to display the corresponding parameter name.
- (5) Press **SRT PAR** to sort the parameter numbers in ascending or descending order.
- (6) Press **←** and **→** to move the cursor to the Group field, enter the value, and press **ENTER** to complete setting the parameter group. You can also stop the cursor at the Group field, press **RED PAR**, and a confirmation window appears. Enter “Y” and press **ENTER** to read the current parameter values and write them to the corresponding fields.
- (7) To delete spare groups, press **←** and **→** to move the cursor to the group field to be deleted, press **DEL GRP**, and a confirmation window appears. Enter “Y” and press **ENTER** to delete the group.
- (8) After entering multiple parameter groups, press **AVERAGE** and a confirmation window appears. Enter “Y” and press **ENTER**, and the system divides the setting range of the parameter by the number of currently used groups, averagely distributing the values to each group field.
- (9) After completing the setting for the values of the parameter group, you can press **SAVE** to save the setting screen and results. When the confirmation window appears, enter “Y” and press **ENTER** to complete the saving step.
- (10) After setting the groups, press **←** and **→** to move the cursor to the specified group field, then press **WRT PAR**, and a confirmation window appears. Enter “Y” and press **ENTER** to write the values to corresponding parameters.

Note:

1. The parameter write function overwrites the original values, so ensure the new values are correct before using this function.
2. The parameter group function supports up to 20 parameters and 20 groups.

## 12.17 Other settings

### 12.17.1 Setting for absolute motor

Follow these steps to set the system when using the NC series controller with an absolute motor.

- (1) In the homing parameter screen, set Pr616 home search mode to 5 (either an incremental or absolute encoder can be used. When you use an absolute motor for the first time, cycle power to the servo and controller after setting the parameter.) Refer to the following figure.

Home		0036ZMC13XZ_1.NC		HL25	SFT
No.	Parameter Name	X	Y	Z	
606	Machine origin coordinate	R 0.000	0.000	0.000	
607	2nd reference coordinate	P 0.000	0.000	-25.100	
608	3rd reference coordinate	P 0.000	0.000	0.000	
609	4th reference coordinate	P 0.000	0.000	0.000	
610	Reference position tolerance	P 0.000	0.000	0.000	
613	Gantry homing calibration amount	R 0	0	0	
616	Origin search mode	P 5	0	0	
617	Origin search setting	P 3	1	1	
	• Homing search direction (negative/positive)	1	1	1	
	• Search home sensor when homing (off/on)	1	0	0	
	• Homing mode of rotation axis	0	0	0	
	• Return mode after reaching home sensor	0	0	0	
	• Homing option for sync. motion	0	0	0	
	• Ignore Z-phase distance (0:off; 1:on)	0	0	0	
	• Gantry homing calibration	0	0	0	

Range: 0 ~ 24

JOG Ch 0 1/2 Ready

PROCESS OPERATE MAGA SPINDLE MACHINE HOME

- (2) After setting the parameter, to reset the absolute encoder, go to **DGN > SYS MON > SRV MON** as shown in the following figure.

Servo Monitor		0036ZMC13XZ_1.NC		HL	SFT				
Ch	Axis	ContRdy	Load	Peak	JL/Jm	Dist. to Z P.	MECH	Home	Abs Rst
0	X	ON	0 %	4 %	0.0	0.0000	-49.047	OK	1
0	Y	OFF						OK	
0	Z	OFF						OK	

JOG RPD 100% JOG 1000 S 100%

SRV MON I/O MON SYS VAR

- (3) Set the system to JOG or MPG mode to use the absolute reset function. In JOG or MPG mode, move the axis to the position to be defined as the origin, enter "1" and press **ENTER** to complete the setting. Meanwhile, the Home indicator is on, meaning that this axis has completed homing.

Note:

1. When a servo alarm occurs, the special M relay for absolute reset (Abs Rst) becomes 0. The following are the relevant alarms that will affect reset.
  - AL060: absolute position is lost. Perform absolute reset.
  - AL061: battery undervoltage. Replace the battery.

AL069: wrong encoder. Ensure an absolute encoder is connected.

2. In MPG mode, the absolute homing setting is only applicable to the currently selected axis. For example, when you select X axis in MPG mode, enter "1" and press **ENTER**, and then only the X axis completes the absolute homing procedure.

## 12.17.2 Setting synchronous motion control

Application description: the A axis (slave axis) is required to follow the Z axis (master axis) in the same direction. Assume that M13 is to enable the synchronous function and M14 is to disable it, the settings are as follows.

1. Set parameter Pr350 to 13.
2. Set parameter Pr351 to 14.
3. Set parameter Pr364 (synchronous control A) to 3.

When M13 is executed, the MLC triggers M1088 (Trigger for synchronous control) and M1092 (A slave axis follows the master axis) at the same time. When the system runs the movement command for Z axis, the A axis moves synchronously. If there is a command to move A axis when the synchronous function is enabled, an alarm occurs since the slave axis (A axis) cannot receive a motion command from the system.

Execute M14 to turn off special M and stop the synchronization function. The synchronous control function is effective in AUTO, MDI, JOG, MPG, and HOME modes.

Important:

- (1) Once you set an axis as a master axis, you cannot set it as a slave axis.
- (2) Once you set an axis as a slave axis, you cannot set it as a master axis.
- (3) Multiple slave axes can follow the same master axis.
- (4) If homing is executed during synchronous control, the system refers to the motion of the master axis.
- (5) Pressing **RESET** does not disable the synchronous control function.

Program:

```
G54X0Y0Z0A0
G90G54G0X10.Y10.Z10.
Z50.
A0
M13
Z0.
Z111.
G4X2.
Z150.
M14
A100.
A51.
M30
```

Relevant parameters:

Parameter No.	Item	Description	Default value	Setting range	Note																				
350 - 359	Halt M-code 1 - 10	Halt M code 1 (0: no setting)	0	0 - 1000	P																				
		Halt M code 2																							
		Halt M code 3																							
		Halt M code 4																							
		Halt M code 5																							
		Halt M code 6																							
		Halt M code 7																							
		Halt M code 8																							
		Halt M code 9																							
		Halt M code 10																							
360	Synchronization direction control	Sets the synchronization direction. Bit 0 - 8: synchronous control of X - W axes 0: same direction 1: different directions	0	0 - 0x3F	P																				
		<table border="1"> <thead> <tr> <th>Function</th> <th>Range</th> </tr> </thead> <tbody> <tr> <td>Synchronous direction for X axis</td> <td>0 - 1</td> </tr> <tr> <td>Synchronous direction for Y axis</td> <td>0 - 1</td> </tr> <tr> <td>Synchronous direction for Z axis</td> <td>0 - 1</td> </tr> <tr> <td>Synchronous direction for A axis</td> <td>0 - 1</td> </tr> <tr> <td>Synchronous direction for B axis</td> <td>0 - 1</td> </tr> <tr> <td>Synchronous direction for C axis</td> <td>0 - 1</td> </tr> <tr> <td>Synchronous direction for U axis</td> <td>0 - 1</td> </tr> <tr> <td>Synchronous direction for V axis</td> <td>0 - 1</td> </tr> <tr> <td>Synchronous direction for W axis</td> <td>0 - 1</td> </tr> </tbody> </table>				Function	Range	Synchronous direction for X axis	0 - 1	Synchronous direction for Y axis	0 - 1	Synchronous direction for Z axis	0 - 1	Synchronous direction for A axis	0 - 1	Synchronous direction for B axis	0 - 1	Synchronous direction for C axis	0 - 1	Synchronous direction for U axis	0 - 1	Synchronous direction for V axis	0 - 1	Synchronous direction for W axis	0 - 1
		Function				Range																			
		Synchronous direction for X axis				0 - 1																			
		Synchronous direction for Y axis				0 - 1																			
		Synchronous direction for Z axis				0 - 1																			
		Synchronous direction for A axis				0 - 1																			
		Synchronous direction for B axis				0 - 1																			
		Synchronous direction for C axis				0 - 1																			
		Synchronous direction for U axis				0 - 1																			
Synchronous direction for V axis	0 - 1																								
Synchronous direction for W axis	0 - 1																								
361	Synchronous control X	Specifies the master axis when X axis is the slave axis. For example, set this parameter to 2 if desiring to set the Y axis as the master axis for synchronous control. 0: off 1 - 9: X - W	0	0 - 9	P																				
362	Synchronous control Y	Specifies the master axis when Y axis is the slave axis. 0: off 1 - 9: X - W	0	0 - 9	P																				
363	Synchronous control Z	Specifies the master axis when Z axis is the slave axis. 0: off 1 - 9: X - W	0	0 - 9	P																				
364	Synchronous control A	Specifies the master axis when A axis is the slave axis. 0: off 1 - 9: X - W	0	0 - 9	P																				
365	Synchronous control B	Specifies the master axis when B axis is the slave axis. 0: off 1 - 9: X - W	0	0 - 9	P																				



Parameter No.	Item	Description	Default value	Setting range	Note
366	Synchronous control C	Specifies the master axis when C axis is the slave axis. 0: off 1 - 9: X - W	0	0 - 9	P
367	Synchronous control U	Specifies the master axis when U axis is the slave axis. 0: off 1 - 9: X - W	0	0 - 9	P
368	Synchronous control V	Specifies the master axis when V axis is the slave axis. 0: off 1 - 9: X - W	0	0 - 9	P
369	Synchronous control W	Specifies the master axis when W axis is the slave axis. 0: off 1 - 9: X - W	0	0 - 9	P

Issue NC command from MLC:

Function description	Special M code
Trigger for synchronous control	M1088
X slave axis follows the master axis	M1089
Y slave axis follows the master axis	M1090
Z slave axis follows the master axis	M1091
A slave axis follows the master axis	M1092
B slave axis follows the master axis	M1093
C slave axis follows the master axis	M1094
U slave axis follows the master axis	M1095
V slave axis follows the master axis	M1096
W slave axis follows the master axis	M1097

### 12.17.3 Command transfer

Application description: transfer the command for Z axis to A axis (transfer axis). Assume that M20 is to enable transfer and M21 is to disable it, the settings are as follows.

1. Set parameter Pr350 to 20.
2. Set parameter Pr351 to 21.
3. Set Pr374 (Transfer control A) to 3.

After executing M20 to trigger M1098 (Transfer command control trigger) and M1102 (A axis receives command from master axis), the system transfers the command originally for the Z axis to the A axis (so, Z axis does not move). If you execute a command for the A axis, an alarm occurs since the transfer axis (A axis) cannot receive any command.

To stop the command transfer function, execute M21 to turn off M1098 in MLC. You can only enable (M20) and disable (M21) this function in AUTO and MDI modes. Please disable this function (M21) when the program ends. The command transfer function is not available in JOG, MPG, and HOME modes.

Important:

- (1) Once you set an axis as a transfer axis, you cannot set it as a master axis.
- (2) Once you set an axis as a master axis, you cannot set it as a transfer axis.
- (3) Multiple transfer axes can refer to the same master axis.
- (4) The transfer function is not available in HOME mode.
- (5) Pressing **RESET** does not disable the command transfer function.
- (6) When the command is transferred from Z axis to A axis, the tool length compensation function is available.
- (7) Transferring the cutting cycle command is applicable on Z axis.

Program:

```
G54X0Y0Z0A0
```

```
G90G54G0X10.Y10.Z10.
```

```
Z50.
```

```
A0
```

```
M20 (The controller pre-reads M20 and then enables command transfer control.)
```

```
Z0. (The movement command for the Z axis coordinate actually moves the A axis)
```

```
Z111.
```

```
G4X2.
```

```
Z150.
```

```
M21 (The controller pre-reads M21 and then disables command transfer control.)
```

```
A100.
```

```
A51.
```

```
M30
```

Relevant parameters:

Parameter No.	Item	Description	Default value	Setting range	Note																				
350 - 359	Halt M-code 1 - 10	Halt M code 1 (0: no setting)	0	0 - 1000	P																				
		Halt M code 2																							
		Halt M code 3																							
		Halt M code 4																							
		Halt M code 5																							
		Halt M code 6																							
		Halt M code 7																							
		Halt M code 8																							
		Halt M code 9																							
		Halt M code 10																							
370	Sets the transfer direction.	Sets the transfer control direction. Bit 0 - 8: synchronous control of X - W 0: same direction 1: different directions	0	0 - 0x3F	P																				
		<table border="1"> <thead> <tr> <th>Function</th> <th>Range</th> </tr> </thead> <tbody> <tr> <td>Transfer direction X</td> <td>0 - 1</td> </tr> <tr> <td>Transfer direction Y</td> <td>0 - 1</td> </tr> <tr> <td>Transfer direction Z</td> <td>0 - 1</td> </tr> <tr> <td>Transfer direction A</td> <td>0 - 1</td> </tr> <tr> <td>Transfer direction B</td> <td>0 - 1</td> </tr> <tr> <td>Transfer direction C</td> <td>0 - 1</td> </tr> <tr> <td>Transfer direction U</td> <td>0 - 1</td> </tr> <tr> <td>Transfer direction V</td> <td>0 - 1</td> </tr> <tr> <td>Transfer direction W</td> <td>0 - 1</td> </tr> </tbody> </table>				Function	Range	Transfer direction X	0 - 1	Transfer direction Y	0 - 1	Transfer direction Z	0 - 1	Transfer direction A	0 - 1	Transfer direction B	0 - 1	Transfer direction C	0 - 1	Transfer direction U	0 - 1	Transfer direction V	0 - 1	Transfer direction W	0 - 1
		Function				Range																			
		Transfer direction X				0 - 1																			
		Transfer direction Y				0 - 1																			
		Transfer direction Z				0 - 1																			
		Transfer direction A				0 - 1																			
		Transfer direction B				0 - 1																			
		Transfer direction C				0 - 1																			
		Transfer direction U				0 - 1																			
Transfer direction V	0 - 1																								
Transfer direction W	0 - 1																								
371	Transfer control X	Specifies the X axis as the axis to receive the transfer command. When transfer control function is enabled, the command is transferred to have the X axis move while the originally commanded axis does not move. For example, set this parameter to 2 if desiring to transfer the control command from the Y axis. 0: off 1 - 9: X - W	0	0 - 9	P																				
372	Transfer control Y	Specifies the Y axis as the axis to receive the transfer command. When transfer control function is enabled, the command is transferred to have the Y axis move while the originally commanded axis does not move. 0: off 1 - 9: X - W	0	0 - 9	P																				
373	Transfer control Z	Specifies the Z axis as the axis to receive the transfer command. When transfer control function is enabled, the command is transferred to have the Z axis move while the originally commanded axis does not move. 0: off 1 - 9: X - W	0	0 - 9	P																				

12

Parameter No.	Item	Description	Default value	Setting range	Note
374	Transfer control A	Specifies the A axis as the axis to receive the transfer command. When transfer control function is enabled, the command is transferred to have the A axis move while the originally commanded axis does not move. 0: off 1 - 9: X - W	0	0 - 9	P
375	Transfer control B	Specifies B axis as the axis to receive the transfer command. When transfer control function is enabled, the command is transferred to have the B axis move while the originally commanded axis does not move. 0: off 1 - 9: X - W	0	0 - 9	P
376	Transfer control C	Specifies the C axis as the axis to receive the transfer command. When transfer control function is enabled, the command is transferred to have the C axis move while the originally commanded axis does not move. 0: off 1 - 9: X - W	0	0 - 9	P
377	Transfer control U	Specifies U axis as the axis to receive the transfer command. When transfer control function is enabled, the command is transferred to have the U axis move while the originally commanded axis does not move. 0: off 1 - 9: X - W	0	0 - 9	P
378	Transfer control V	Specifies the V axis as the axis to receive the transfer command. When transfer control function is enabled, the command is transferred to have the V axis move while the originally commanded axis does not move. 0: off 1 - 9: X - W	0	0 - 9	P
379	Transfer control W	Specifies W axis as the axis to receive the transfer command. When transfer control function is enabled, the command is transferred to have the W axis move while the originally commanded axis does not move. 0: off 1 - 9: X - W	0	0 - 9	P

Issue NC command from MLC:

Function description	Special M code
Trigger flag of transfer command controls	M1098
X axis receives command from master axis	M1099
Y axis receives command from master axis	M1100
Z axis receives command from master axis	M1101
A axis receives command from master axis	M1102
B axis receives command from master axis	M1103
C axis receives command from master axis	M1104
U axis receives command from master axis	M1105
V axis receives command from master axis	M1106
W axis receives command from master axis	M1107

Special M for enabling transfer function:

Function description	Special M code
Transfer function in execution	M2228

# Software (SOFT) Group

---

# 13

The SOFT group is for configuring user-defined screens with the CNCSoft software.  
This chapter provides the example screens.



13.1	ScreenEditor software.....	13-2
------	----------------------------	------

With the SOFT group function, you can use ScreenEditor to configure the screens, which can replace the function of the machine operation panel B or add customized extension functions.

Note: **Function names** in a box (such as POS) mean the keys on machine operation panel A; bold **function names** (such as CLR ALL) mean the function keys of F1 - F6.

### 13.1 ScreenEditor software

■ ScreenEditor

You can edit the screens of the controller with ScreenEditor which you can enter from the CNC portal on the main page of the Delta CNCSoft software, as shown in Figure 13.1.1.



Figure 13.1.1

■ After entering ScreenEditor, you can see the operation interface as shown in Figure 13.1.2.

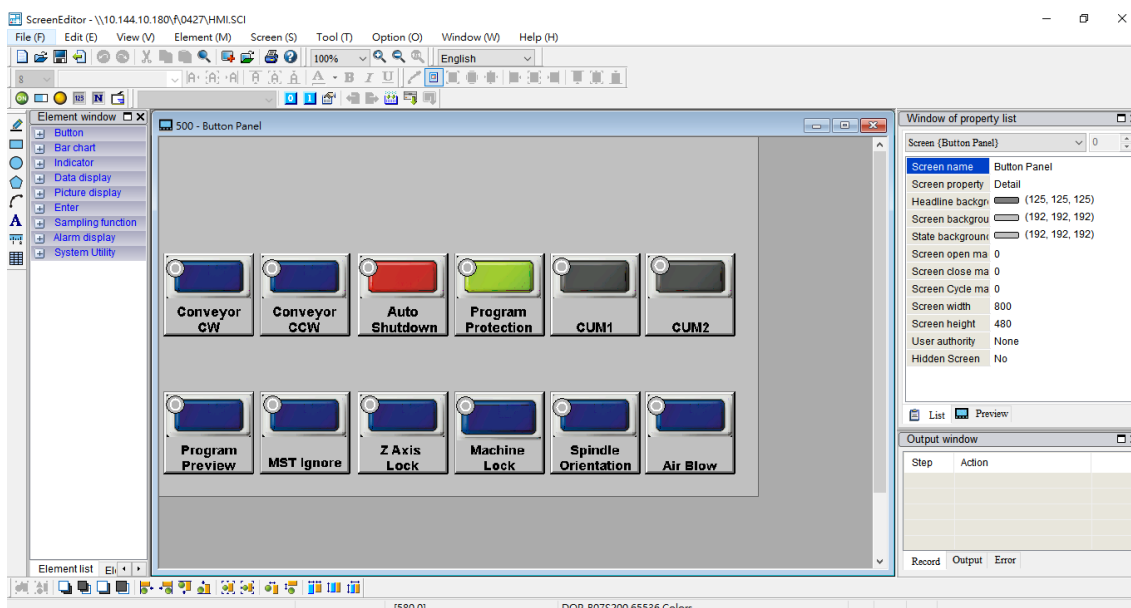

Figure 13.1.2

- After compiling the screens and creating the screen data files, you can import the files to the controller using the USB disk or the Internet, as shown in Figure 13.1.3.

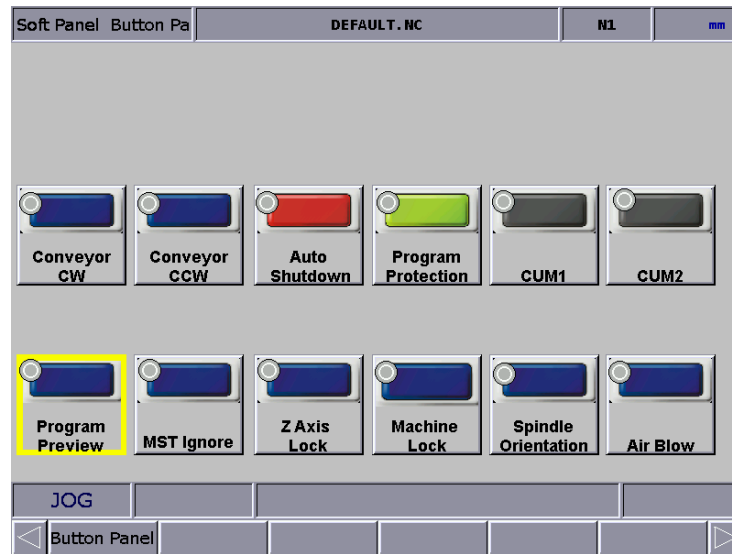

Figure 13.1.3



(This page is intentionally left blank.)

13

# MLC Special M Relay and Special D Register

---

# 14

This chapter provides detailed descriptions for the special controlling devices of the NC system, through which you can quickly check the MLC status in the NC system. For more advanced control functions, refer to NC Series MLC Application Manual.

14.1	MLC special M and D definitions.....	14-2
14.2	Special M summary table .....	14-3
14.3	Special D summary table .....	14-27

## 14.1 MLC special M and D definitions

14 MLC (Motion Logic Control) and the NC system are two independent systems. You can use the MLC to perform various logical controls for the knob button, mechanism actions or other motors. The NC system, on the other hand, manages system and servo axis related functions. When the two systems need to communicate with each other, the special M and special D of MLC must be used as the input/output interface to process the data exchanging and messaging of the two sides.

The signal sent by special M and special D of MLC to the NC system is called output; on the other hand, the signal sent by the NC system to special M and special D of MLC is called input. MLC codes begin with M and are in Bit form, its signal is 0 (OFF) or 1 (ON); codes that begin with D are Word form, and represents a value, such as 1000. The special M and special D codes of MLC all use the 4 numbers after M and D to indicate the number.

Data exchange is divided into the following four major groups:

- 1: MLC bit output from MLC to NC (special M device with Bit output)
- 2: MLC bit input from NC to MLC (special M device with Bit input)
- 3: MLC character output from MLC to NC (special D device with Word output)
- 4: MLC bit input from NC to MLC (special D device with Word input)

## 14.2 Special M summary table

The definitions and classifications of all special M and D of the NC system are as follows.

Function name	Special M	Description	Device type																																																				
HMI output point 1	M1024	Corresponds its status to the system variable, #1801.	R/W																																																				
HMI output point 2	M1025	Corresponds its status to the system variable, #1802.	R/W																																																				
HMI output point 3	M1026	Corresponds its status to the system variable, #1803.	R/W																																																				
HMI output point 4	M1027	Corresponds its status to the system variable, #1804.	R/W																																																				
HMI output point 5	M1028	Corresponds its status to the system variable, #1805.	R/W																																																				
HMI output point 6	M1029	Corresponds its status to the system variable, #1806.	R/W																																																				
HMI output point 7	M1030	Corresponds its status to the system variable, #1807.	R/W																																																				
HMI output point 8	M1031	Corresponds its status to the system variable, #1808.	R/W																																																				
HMI output point 9	M1032	Corresponds its status to the system variable, #1809.	R/W																																																				
HMI output point 10	M1033	Corresponds its status to the system variable, #1810.	R/W																																																				
HMI output point 11	M1034	Corresponds its status to the system variable, #1811.	R/W																																																				
HMI output point 12	M1035	Corresponds its status to the system variable, #1812.	R/W																																																				
HMI output point 13	M1036	Corresponds its status to the system variable, #1813.	R/W																																																				
HMI output point 14	M1037	Corresponds its status to the system variable, #1814.	R/W																																																				
HMI output point 15	M1038	Corresponds its status to the system variable, #1815.	R/W																																																				
HMI output point 16	M1039	Corresponds its status to the system variable, #1816.	R/W																																																				
HMI output point 17	M1040	Corresponds its status to the system variable, #1817.	R/W																																																				
HMI output point 18	M1041	Corresponds its status to the system variable, #1818.	R/W																																																				
HMI output point 19	M1042	Corresponds its status to the system variable, #1819.	R/W																																																				
HMI output point 20	M1043	Corresponds its status to the system variable, #1820.	R/W																																																				
HMI output point 21	M1044	Corresponds its status to the system variable, #1821.	R/W																																																				
HMI output point 22	M1045	Corresponds its status to the system variable, #1822.	R/W																																																				
HMI output point 23	M1046	Corresponds its status to the system variable, #1823.	R/W																																																				
HMIe output point 24	M1047	Corresponds its status to the system variable, #1824.	R/W																																																				
HMIe output point 25	M1048	Corresponds its status to the system variable, #1825.	R/W																																																				
HMI output point 26	M1049	Corresponds its status to the system variable, #1826.	R/W																																																				
HMI output point 27	M1050	Corresponds its status to the system variable, #1827.	R/W																																																				
HMI output point 28	M1051	Corresponds its status to the system variable, #1828.	R/W																																																				
HMI output point 29	M1052	Corresponds its status to the system variable, #1829.	R/W																																																				
HMI output point 30	M1053	Corresponds its status to the system variable, #1830.	R/W																																																				
HMI output point 31	M1054	Corresponds its status to the system variable, #1831.	R/W																																																				
HMI output point 32	M1055	Corresponds its status to the system variable, #1832.	R/W																																																				
System mode selections: 0: AUTO 1: EDIT 2: MDI 3: MPG 4: JOG 5: RAPID 6: HOME	M1056 M1057 M1058 M1059	Users control the statuses of M1056 - M1059 to achieve system mode switching. <table border="1"> <thead> <tr> <th colspan="4">Binary</th> <th rowspan="2">Decimal</th> <th rowspan="2">System mode</th> </tr> <tr> <th>M1059 (Bit 3)</th> <th>M1058 (Bit 2)</th> <th>M1057 (Bit 1)</th> <th>M1056 (Bit 0)</th> </tr> </thead> <tbody> <tr><td>0</td><td>0</td><td>0</td><td>0</td><td>0</td><td>AUTO</td></tr> <tr><td>0</td><td>0</td><td>0</td><td>1</td><td>1</td><td>EDIT</td></tr> <tr><td>0</td><td>0</td><td>1</td><td>0</td><td>2</td><td>MDI</td></tr> <tr><td>0</td><td>0</td><td>1</td><td>1</td><td>3</td><td>MPG</td></tr> <tr><td>0</td><td>1</td><td>0</td><td>0</td><td>4</td><td>JOG</td></tr> <tr><td>0</td><td>1</td><td>0</td><td>1</td><td>5</td><td>RAPID</td></tr> <tr><td>0</td><td>1</td><td>1</td><td>0</td><td>6</td><td>HOME</td></tr> </tbody> </table>	Binary				Decimal	System mode	M1059 (Bit 3)	M1058 (Bit 2)	M1057 (Bit 1)	M1056 (Bit 0)	0	0	0	0	0	AUTO	0	0	0	1	1	EDIT	0	0	1	0	2	MDI	0	0	1	1	3	MPG	0	1	0	0	4	JOG	0	1	0	1	5	RAPID	0	1	1	0	6	HOME	R/W
Binary				Decimal	System mode																																																		
M1059 (Bit 3)	M1058 (Bit 2)	M1057 (Bit 1)	M1056 (Bit 0)																																																				
0	0	0	0	0	AUTO																																																		
0	0	0	1	1	EDIT																																																		
0	0	1	0	2	MDI																																																		
0	0	1	1	3	MPG																																																		
0	1	0	0	4	JOG																																																		
0	1	0	1	5	RAPID																																																		
0	1	1	0	6	HOME																																																		

Function name	Special M	Description	Device type
Single block execution	M1060	In AUTO mode, program pauses after one block is executed.	R/W
Cycle Start	M1061	Notifies the system to perform cycle start.	R/W
NC pause	M1062	After M1056 is triggered, the NC controller will pause immediately.	R/W
System stop	M1063	System stops machining operations.	R/W
System reset	M1064	After M1076 or the reset signal of machine operation panel A is triggered, the system will reset, and M1064 is triggered.	R
Dry run	M1065	After M1065 is triggered, the moving speed F of G01 in AUTO mode refers to the feedrate assigned in the D1062 register.	R/M
Optional stop (M01 program stop)	M1066	Optional stop key. When the program runs to M01, the controller stops immediately.	R/W
Single block skip ('/')	M1067	The program skips the block containing symbol '/' when this function is enabled.	R/W
Lock all axes movements	M1068	Locks all X, Y and Z axes of the machine so they cannot move.	R/W
Lock Z axis movement	M1069	Locks the Z axis of the machine so it cannot move.	R/W
Limit release	M1070	When this function is enabled, the limit signal of each axis is ignored.	R/W
Lock M, S and T codes	M1071	The program skips M, S, and T codes in the execution.	R/W
DMCNET connection successful	M1072	The MLC sends this signal after the system confirms that the DMCNET connection is successful. Note that this signal signifies the connection is successful instead of the Servo On status.	R
Macro call initialization ready	M1074	Macro call initialization (requires AUTO mode and the correct Macro ID to initialize successfully).	R/W
Macro call start	M1075	Macro program call start (requires AUTO mode and the correct Macro ID to complete initialization before it can start correctly).	R/W
System reset	M1076	When this signal is triggered, the system will reset (MLC > NC).	R/W
M99 main program stop	M1077	When M1077 is set as ON, the system stops machining when it reads M99 in the main program.	R/W
M96 subroutine interruption	M1078	When this signal is triggered, the system executes M96 to interrupt the subroutine.	R/W
MLC emergency stop trigger	M1079	Works with the parameter Pr305 [Emergency stop source] setting; when M1079 is set to ON, the system triggers the emergency stop.	R/W
MPG simulation	M1080	While the program is running, it uses the operationspeed of MPG to control the movement speed of the motion trajectory.	R/W
Restricted zone protection release function	M1085	The protection of restricted zones is released when M1085 is triggered.	R/W
Synchronous control trigger	M1088	When using the synchronous function, you must set this special Mto On to have the system enable the synchronous function.	R/W
X slave axis follows the master axis	M1089	Makes X axis the slave axis in the synchronous function.	R/W
Y slave axis follows the master axis	M1090	Makes Y axis the slave axis in the synchronous function.	R/W
Z slave axis follows the master axis	M1091	Makes Z axis the slave axis in the synchronous function.	R/W

Function name	Special M	Description	Device type
A slave axis follows the master axis	M1092	Makes A axis the slave axis in the synchronous function.	R/W
B slave axis follows the master axis	M1093	Makes B axis the slave axis in the synchronous function.	R/W
C slave axis follows the master axis	M1094	Makes C axis the slave axis in the synchronous function.	R/W
U slave axis follows the master axis	M1095	Makes U axis the slave axis in the synchronous function.	R/W
V slave axis follows the master axis	M1096	Makes V axis the slave axis in the synchronous function.	R/W
W slave axis follows the master axis	M1097	Makes W axis the slave axis in the synchronous function.	R/W
Transfer command control trigger	M1098	When using transfer command functions, you must set M1098 to On to have the system enable the transfer command function.	R/W
X axis receives command from master axis	M1099	Makes X axis the axis that receives command in the transfer command function.	R/W
Y axis receives command from master axis	M1100	Makes Y axis the axis that receives command in the transfer command function.	R/W
Z axis receives command from master axis	M1101	Makes Z axis the axis that receives command in the transfer command function.	R/W
A axis receives command from master axis	M1102	Makes A axis the axis that receives command in the transfer command function.	R/W
B axis receives command from master axis	M1103	Makes B axis the axis that receives command in the transfer command function.	R/W
C axis receives command from master axis	M1104	Makes C axis the axis that receives command in the transfer command function.	R/W
U axis receives command from master axis	M1105	Makes U axis the axis that receives command in the transfer command function.	R/W
V axis receives command from master axis	M1106	Makes V axis the axis that receives command in the transfer command function.	R/W
W axis receives command from master axis	M1107	Makes W axis the axis that receives command in the transfer command function.	R/W
Panel MPG pulse +	M1118	Uses machine operation panel B to trigger the MPG function; this is a positive trigger signal, refer to the explanation of D1040 for the enabling method.	R/W
Panel MPG pulse -	M1119	Uses machine operation panel B to trigger the MPG function; this is a reverse trigger signal, refer to the explanation of D1040 for the enabling method.	R/W
Spindle forward rotation	M1120	Spindle forward rotation.	R/W
Spindle reverse rotation	M1121	Spindle reverse rotation.	R/W

Function name	Special M	Description	Device type
Spindle gear ratio selection	M1122 M1123	The selection of the spindle gear ratio uses M1122 - M1123 to represent Bit 0 - Bit 1 in binary format. If converted to decimal format, M1122 and M1123 correspond to 0 - 3, representing the four sets of gear ratios of the spindle parameters Pr422 - Pr429. For example, if you select the spindle parameter Pr428 - Pr429 gear ratio numerator 4 and gear ratio denominator 4, which is 3 in decimal format and 0011 in binary format, the two bits of the MLC correspond to M1122 and M1123 respectively, so the On and Off states corresponding to the bits are as follows. M1122 = ON M1123 = ON	R/W
Spindle positioning control	M1124	Spindle positioning function.	R/W
Spindle retraction after tapping	M1125	Spindle retraction after tapping.	R/W
Lathe spindle / C axis mode switch	M1126	You can trigger this special M to perform C axis and spindle mode-switching function on the lathe system. Note: only available on the lathe system.	R/W
Spindle analog voltage ratio gain	M1127	Use this special M to select the parameter that the spindle analog voltage ratio gain will refer to. When M1127 = On, refer to Pr413. When M1127 = Off, refer to Pr419.	R/W
M, S, and T codes execution complete	M1152	When M1152 is triggered, it notifies the NC system that the M, S and T code actions are complete.	R/W
Tool magazine 1 forward operation	M1168	Tool magazine 1 operates in forward direction. When this special M is triggered, the incremental station number (D1372) of the tool decreases by 1 and the standby tool number (D1373) increases by 1.	R/W
Tool magazine 1 reverse operation	M1169	Tool magazine 1 operates in reverse direction. When this special M is triggered, the incremental station number (D1372) of the tool increases by 1 and the standby tool number (D1373) decreases by 1.	R/W
Tool 1 exchange	M1170	Exchanges tool data in tool magazine 1.	R/W
Tool magazine 1 reset	M1171	When this signal is triggered, the tool number data in tool magazine 1 is reset.	R/W
Tool magazine 2 forward operation	M1172	Tool magazine 2 operates in forward direction. When this special M is triggered, the incremental station number (D1376) of the tool decreases by 1 and the standby tool number (D1377) increases by 1.	R/W
Tool magazine 2 reverse operation	M1173	Tool magazine 2 operates in reverse direction. When this special M is triggered, the incremental station number (D1376) of the tool increases by 1 and the standby tool number (D1377) decreases by 1.	R/W
Tool 2 exchange	M1174	Exchanges tool data in tool magazine 2.	R/W
Tool magazine 2 reset	M1175	When this signal is triggered, the tool number data in tool magazine 2 is reset.	R/W
X axis movement trigger (MLC axis)	M1184	X axis control trigger of the MLC.	R/W
Y axis movement trigger (MLC axis)	M1185	Y axis control trigger of the MLC.	R/W
Z axis movement trigger (MLC axis)	M1186	Z axis control trigger of the MLC.	R/W

Function name	Special M	Description	Device type
A axis movement trigger (MLC axis)	M1187	A axis control trigger of the MLC.	R/W
B axis movement trigger (MLC axis)	M1188	B axis control trigger of the MLC.	R/W
C axis movement trigger (MLC axis)	M1189	C axis control trigger of the MLC.	R/W
U axis movement trigger (MLC axis)	M1190	U axis control trigger of the MLC.	R/W
V axis movement trigger (MLC axis)	M1191	V axis control trigger of the MLC.	R/W
W axis movement trigger (MLC axis)	M1192	W axis control trigger of the MLC.	R/W
Spindle movement trigger (MLC axis)	M1193	Spindle control trigger of the MLC.	R/W
MLC axis incremental movement command	M1194	Regards the positioning value of the special D assigned by each MLC axis as incremental.	R/W
NC / MLC switching (X axis)	M1200	When M1200 is On, switch to X axis of the MLC system. When M1200 is Off, switch to X axis of the NC system.	R/W
NC / MLC switching (Y axis)	M1201	When M1201 is On, switch to Y axis of the MLC system. When M1201 is Off, switch to Y axis of the NC system.	R/W
NC / MLC switching (Z axis)	M1202	When M1202 is On, switch to Z axis of the MLC system. When M1202 is Off, switch to Z axis of the NC system.	R/W
NC / MLC switching (A axis)	M1203	When M1203 is On, switch to A axis of the MLC system. When M1203 is Off, switch to A axis of the NC system.	R/W
S NC / MLC switching (B axis)	M1204	When M1204 is On, switch to B axis of the MLC system. When M1204 is Off, switch to B axis of the NC system.	R/W
NC / MLC switching (C axis)	M1205	When M1205 is On, switch to C axis of the MLC system. When M1205 is Off, switch to C axis of the NC system.	R/W
NC / MLC switching (U axis)	M1206	When M1206 is On, switch to U axis of the MLC system. When M1206 is Off, switch to U axis of the NC system.	R/W
NC / MLC switching (V axis)	M1207	When M1207 is On, switch to V axis of the MLC system. When M1207 is Off, switch to V axis of the NC system.	R/W
Switch NC axis to MLC axis (W axis)	M1208	When M1208 is On, switch to W axis of the MLC system. When M1208 is Off, switch to W axis of the NC system.	R/W
X axis forward jog control	M1216	Trigger for X axis forward jog operation.	R/W
Y axis forward jog control	M1217	Trigger for Y axis forward jog operation.	R/W
Z axis forward jog control	M1218	Trigger for Z axis forward jog operation.	R/W
A axis forward jog control	M1219	Trigger for A axis forward jog operation.	R/W
B axis forward jog control	M1220	Trigger for B axis forward jog operation.	R/W
C axis forward jog control	M1221	Trigger for C axis forward jog operation.	R/W
U axis forward jog control	M1222	Trigger for U axis forward jog operation.	R/W



Function name	Special M	Description	Device type
V axis forward jog control	M1223	Trigger for V axis forward jog operation.	R/W
W axis forward jog control	M1224	Trigger for W axis forward jog operation.	R/W
X axis reverse jog control	M1226	Trigger for X axis reverse jog operation.	R/W
Y axis reverse jog control	M1227	Trigger for Y axis reverse jog operation.	R/W
Z axis reverse jog control	M1228	Trigger for Z axis reverse jog operation.	R/W
A axis reverse jog control	M1229	Trigger for A axis reverse jog operation.	R/W
B axis reverse jog control	M1230	Trigger for B axis reverse jog operation.	R/W
C axis reverse jog control	M1231	Trigger for C axis reverse jog operation.	R/W
U axis reverse jog control	M1232	Trigger for U axis reverse jog operation.	R/W
V axis reverse jog control	M1233	Trigger for V axis reverse jog operation.	R/W
W axis reverse jog control	M1234	Trigger for W axis reverse jog operation.	R/W
X axis homing control	M1236	Trigger for X axis homing operation.	R/W
Y axis homing control	M1237	Trigger for Y axis homing operation.	R/W
Z axis homing control	M1238	Trigger for Z axis homing operation.	R/W
A axis homing control	M1239	Trigger for A axis homing operation.	R/W
B axis homing control	M1240	Trigger for B axis homing operation.	R/W
C axis homing control	M1241	Trigger for C axis homing operation.	R/W
U axis homing control	M1242	Trigger for U axis homing operation.	R/W
V axis return home control	M1243	Trigger for V axis homing operation.	R/W
W axis homing control	M1244	Trigger for W axis homing operation.	R/W
Cancel X axis 1 <sup>st</sup> software limit	M1248	Trigger for cancelling X axis 1 <sup>st</sup> software limit.	R/W
Cancel Y axis 1 <sup>st</sup> software limit	M1249	Trigger for cancelling Y axis 1 <sup>st</sup> software limit.	R/W
Cancel Z axis 1 <sup>st</sup> software limit	M1250	Trigger for cancelling Z axis 1 <sup>st</sup> software limit.	R/W
Cancel A axis 1 <sup>st</sup> software limit	M1251	Trigger for cancelling A axis 1 <sup>st</sup> software limit.	R/W
Cancel B axis 1 <sup>st</sup> software limit	M1252	Trigger for cancelling B axis 1 <sup>st</sup> software limit.	R/W
Cancel C axis 1 <sup>st</sup> software limit	M1253	Trigger for cancelling C axis 1 <sup>st</sup> software limit.	R/W
Cancel U axis 1 <sup>st</sup> software limit	M1254	Trigger for cancelling U axis 1 <sup>st</sup> software limit.	R/W
Cancel V axis 1 <sup>st</sup> software limit	M1255	Trigger for cancelling V axis 1 <sup>st</sup> software limit.	R/W
Cancel W axis 1 <sup>st</sup> software limit	M1256	Trigger for cancelling W axis 1 <sup>st</sup> software limit.	R/W
Lock X axis	M1257	Trigger for locking X axis.	R/W
Lock Y axis	M1258	Trigger for locking Y axis.	R/W
Lock Z axis	M1259	Trigger for locking Z axis.	R/W

Function name	Special M	Description	Device type
Lock A axis	M1260	Trigger for locking A axis.	R/W
Lock B axis	M1261	Trigger for locking B axis.	R/W
Lock C axis	M1262	Trigger for locking C axis.	R/W
Lock U axis	M1263	Trigger for locking U axis.	R/W
Lock V axis	M1264	Trigger for locking V axis.	R/W
Lock W axis	M1265	Trigger for locking W axis.	R/W
X axis Servo Off	M1266	Trigger for X axis Servo Off.	R/W
Y axis Servo Off	M1267	Trigger for Y axis Servo Off.	R/W
Z axis Servo Off	M1268	Trigger for Z axis Servo Off.	R/W
A axis Servo Off	M1269	Trigger for A axis Servo Off.	R/W
B axis Servo Off	M1270	Trigger for B axis Servo Off.	R/W
C axis Servo Off	M1271	Trigger for C axis Servo Off.	R/W
U axis Servo Off	M1272	Trigger for U axis Servo Off.	R/W
V axis Servo Off	M1273	Trigger for V axis Servo Off.	R/W
W axis Servo Off	M1274	Trigger for W axis Servo Off.	R/W
MLC X axis increment switch	M1280	Regards the value of D1064 of the MLC X axis as incremental.	R/W
MLC Y axis increment switch	M1281	Regards the value of D1066 of the MLC Y axis as incremental.	R/W
MLC Z axis increment switch	M1282	Regards the value of D1068 of the MLC Z axis as incremental.	R/W
MLC A axis increment switch	M1283	Regards the value of D1070 of the MLC A axis as incremental.	R/W
MLC B axis increment switch	M1284	Regards the value of D1072 of the MLC B axis as incremental.	R/W
MLC C axis increment switch	M1285	Regards the value of D1074 of the MLC C axis as incremental.	R/W
MLC U axis increment switch	M1286	Regards the value of D1076 of the MLC U axis as incremental.	R/W
MLC V axis increment switch	M1287	Regards the value of D1078 of the MLC V axis as incremental.	R/W
MLC W axis increment switch	M1288	Regards the value of D1080 of the MLC W axis as incremental.	R/W
MLC X axis control mode	M1289	When M1289 is On, regards the MLC X axis operation as in Speed mode. When M1289 is Off, regards the MLC X axis operation as in Position mode.	R/W
MLC Y axis control mode	M1290	When M1290 is On, regards the MLC Y axis operation as in Speed mode. When M1290 is Off, regards the MLC Y axis operation as in Position mode.	R/W
MLC Z axis control mode	M1291	When M1291 is On, regards the MLC Z axis operation as in Speed mode. When M1291 is Off, regards the MLC Z axis operation as in Position mode.	R/W
MLC A axis control mode	M1292	When M1292 is On, regards the MLC A axis operation as in Speed mode. When M1292 is Off, regards the MLC A axis operation as in Position mode.	R/W
MLC B axis control mode	M1293	When M1293 is On, regards the MLC B axis operation as in Speed mode. When M1293 is Off, regards the MLC B axis operation as in Position mode.	R/W
MLC C axis control mode	M1294	When M1294 is On, regards the MLC C axis operation as in Speed mode. When M1294 is Off, regards the MLC C axis operation as in Position mode.	R/W
MLC U axis control mode	M1295	When M1295 is On, regards the MLC U axis operation as in Speed mode. When M1295 is Off, regards the MLC U axis operation as in Position mode.	R/W

Function name	Special M	Description	Device type
MLC V axis control mode	M1296	When M1296 is On, regards the MLC V axis operation as in Speed mode. When M1296 is Off, regards the MLC V axis operation as in Position mode.	R/W
MLC W axis control mode	M1297	When M1297 is On, regards the MLC W axis operation as in Speed mode. When M1297 is Off, regards the MLC W axis operation as in Position mode.	R/W
MLC X axis high speed input trigger	M1298	If M1298 is set to On when the MLC axis is operating and the corresponding DI for the X axis is triggered, the MLC X axis immediately stops.	R/W
MLC Y axis high speed input trigger	M1299	If M1299 is set to On when the MLC axis is operating and the corresponding DI for the Y axis is triggered, the MLC Y axis immediately stops.	R/W
MLC Z axis high speed input trigger	M1300	If M1300 is set to On when the MLC axis is operating and the corresponding DI for the Z axis is triggered, the MLC Z axis immediately stops.	R/W
MLC A axis high speed input trigger	M1301	If M1301 is set to On when the MLC axis is operating and the corresponding DI for the A axis is triggered, the MLC A axis immediately stops.	R/W
MLC B axis high speed input trigger	M1302	If M1302 is set to On when the MLC axis is operating and the corresponding DI for the B axis is triggered, the MLC B axis immediately stops.	R/W
MLC C axis high speed input trigger	M1303	If M1303 is set to On when the MLC axis is operating and the corresponding DI for the C axis is triggered, the MLC C axis immediately stops.	R/W
MLC U axis high speed input trigger	M1304	If M1304 is set to On when the MLC axis is operating and the corresponding DI for the U axis is triggered, the MLC U axis immediately stops.	R/W
MLC V axis high speed input trigger	M1305	If M1305 is set to On when the MLC axis is operating and the corresponding DI for the V axis is triggered, the MLC V axis immediately stops.	R/W
MLC W axis high speed input trigger	M1306	If M1306 is set to On when the MLC axis is operating and the corresponding DI for the W axis is triggered, the MLC W axis immediately stops.	R/W
Spindle speed command source	M1307	When M1307 is On, the spindle speed command refers to the setting of D1148. When M1307 is set to Off, the spindle speed command refers to the S code setting.	R/W
X axis movement permission	M1312	When Pr501 [X axis movement protection] is set to 1, you need to set M1312 to On for the X axis to move during machining.	R/W
Y axis movement permission	M1313	When Pr501 [Y axis movement protection] is set to 1, you need to set M1313 to On for the Y axis to move during machining.	R/W
Z axis movement permission	M1314	When Pr501 [Z axis movement protection] is set to 1, you need to set M1314 to On for the Z axis to move during machining.	R/W
A axis movement permission	M1315	When Pr501 [A axis movement protection] is set to 1, you need to set M1315 to On for the A axis to move during machining.	R/W
B axis movement permission	M1316	When Pr501 [B axis movement protection] is set to 1, you need to set M1316 to On for the B axis to move during machining.	R/W
C axis movement permission	M1317	When Pr501 [C axis movement protection] is set to 1, you need to set M1317 to On for the C axis to move during machining.	R/W
U axis movement permission	M1318	When Pr501 [U axis movement protection] is set to 1, you need to set M1318 to On for the U axis to move during machining.	R/W

Function name	Special M	Description	Device type
V axis movement permission	M1319	When Pr501 [V axis movement protection] is set to 1, you need to set M1319 to On for the V axis to move during machining.	R/W
W axis movement permission	M1320	When Pr501 [W axis movement protection] is set to 1, you need to set M1320 to On for the W axis to move during machining.	R/W
Lock machine X axis positive operation	M1344	<ul style="list-style-type: none"> <li>■ In Auto or MDI mode, when Pr485 [Enable the lock for positive/negative axis operation in AUTO mode] is set to 1 and M1344 is set to On, the X axis does not move in positive direction.</li> <li>■ In JOG, MPG, or Rapid mode, if M1344 is set to On, the X axis does not move in positive direction regardless of the parameter setting.</li> <li>■ In HOME mode, of M1344 is set to On, the X axis does not perform the homing procedure.</li> </ul>	R/W
Lock machine Y axis positive operation	M1345	<ul style="list-style-type: none"> <li>■ In Auto or MDI mode, when Pr485 [Enable the lock for positive/negative axis operation in AUTO mode] is set to 1 and M1345 is set to On, the Y axis does not move in positive direction.</li> <li>■ In JOG, MPG, or Rapid mode, if M1345 is set to On, the Y axis does not move in positive direction regardless of the parameter setting.</li> <li>■ In HOME mode, of M1345 is set to On, the Y axis does not perform the homing procedure.</li> </ul>	R/W
Lock machine Z axis positive operation	M1346	<ul style="list-style-type: none"> <li>■ In Auto or MDI mode, when Pr485 [Enable the lock for positive/negative axis operation in AUTO mode] is set to 1 and M1346 is set to On, the Z axis does not move in positive direction.</li> <li>■ In JOG, MPG, or Rapid mode, if M1346 is set to On, the Y axis does not move in positive direction regardless of the parameter setting.</li> <li>■ In HOME mode, of M1346 is set to On, the Z axis does not perform the homing procedure.</li> </ul>	R/W
Lock machine A axis positive operation	M1347	<ul style="list-style-type: none"> <li>■ In Auto or MDI mode, when Pr485 [Enable the lock for positive/negative axis operation in AUTO mode] is set to 1 and M1347 is set to On, the A axis does not move in positive direction.</li> <li>■ In JOG, MPG, or Rapid mode, if M1347 is set to On, the A axis does not move in positive direction regardless of the parameter setting.</li> <li>■ In HOME mode, of M1347 is set to On, the A axis does not perform the homing procedure.</li> </ul>	R/W
Lock machine B axis positive operation	M1348	<ul style="list-style-type: none"> <li>■ In Auto or MDI mode, when Pr485 [Enable the lock for positive/negative axis operation in AUTO mode] is set to 1 and M1348 is set to On, the B axis does not move in positive direction.</li> <li>■ In JOG, MPG, or Rapid mode, if M1348 is set to On, the B axis does not move in positive direction regardless of the parameter setting.</li> <li>■ In HOME mode, of M1348 is set to On, the B axis does not perform the homing procedure.</li> </ul>	R/W
Lock machine C axis positive operation	M1349	<ul style="list-style-type: none"> <li>■ In Auto or MDI mode, when Pr485 [Enable the lock for positive/negative axis operation in AUTO mode] is set to 1 and M1349 is set to On, the C axis does not move in positive direction.</li> <li>■ In JOG, MPG, or Rapid mode, if M1349 is set to On, the C axis does not move in positive direction regardless of the parameter setting.</li> <li>■ In HOME mode, of M1349 is set to On, the C axis does not perform the homing procedure.</li> </ul>	R/W

Function name	Special M	Description	Device type
Lock machine U axis positive operation	M1350	<ul style="list-style-type: none"> <li>■ In Auto or MDI mode, when Pr485 [Enable the lock for positive/negative axis operation in AUTO mode] is set to 1 and M1350 is set to On, the U axis does not move in positive direction.</li> <li>■ In JOG, MPG, or Rapid mode, if M1350 is set to On, the U axis does not move in positive direction regardless of the parameter setting.</li> <li>■ In HOME mode, of M1350 is set to On, the U axis does not perform the homing procedure.</li> </ul>	R/W
Lock machine V axis positive operation	M1351	<ul style="list-style-type: none"> <li>■ In Auto or MDI mode, when Pr485 [Enable the lock for positive/negative axis operation in AUTO mode] is set to 1 and M1351 is set to On, the V axis does not move in positive direction.</li> <li>■ In JOG, MPG, or Rapid mode, if M1351 is set to On, the V axis does not move in positive direction regardless of the parameter setting.</li> <li>■ In HOME mode, of M1351 is set to On, the V axis does not perform the homing procedure.</li> </ul>	R/W
Lock machine W axis positive operation	M1352	<ul style="list-style-type: none"> <li>■ In Auto or MDI mode, when Pr485 [Enable the lock for positive/negative axis operation in AUTO mode] is set to 1 and M1352 is set to On, the W axis does not move in positive direction.</li> <li>■ In JOG, MPG, or Rapid mode, if M1352 is set to On, the W axis does not move in positive direction regardless of the parameter setting.</li> <li>■ In HOME mode, of M1352 is set to On, the W axis does not perform the homing procedure.</li> </ul>	R/W
Lock machine X axis negative operation	M1353	<ul style="list-style-type: none"> <li>■ In Auto or MDI mode, when Pr485 [Enable the lock for positive/negative axis operation in AUTO mode] is set to 1 and M1353 is set to On, the X axis does not move in negative direction.</li> <li>■ In JOG, MPG, or Rapid mode, if M1353 is set to On, the X axis does not move in negative direction regardless of the parameter setting.</li> <li>■ In HOME mode, of M1353 is set to On, the X axis does not perform the homing procedure.</li> </ul>	R/W
Lock machine Y axis negative operation	M1354	<ul style="list-style-type: none"> <li>■ In Auto or MDI mode, when Pr485 [Enable the lock for positive/negative axis operation in AUTO mode] is set to 1 and M1354 is set to On, the Y axis does not move in negative direction.</li> <li>■ In JOG, MPG, or Rapid mode, if M1354 is set to On, the Y axis does not move in negative direction regardless of the parameter setting.</li> <li>■ In HOME mode, of M1354 is set to On, the Y axis does not perform the homing procedure.</li> </ul>	R/W
Lock machine Z axis negative operation	M1355	<ul style="list-style-type: none"> <li>■ In Auto or MDI mode, when Pr485 [Enable the lock for positive/negative axis operation in AUTO mode] is set to 1 and M1355 is set to On, the Z axis does not move in negative direction.</li> <li>■ In JOG, MPG, or Rapid mode, if M1355 is set to On, the Z axis does not move in negative direction regardless of the parameter setting.</li> <li>■ In HOME mode, of M1355 is set to On, the Z axis does not perform the homing procedure.</li> </ul>	R/W

Function name	Special M	Description	Device type
Lock machine A axis negative operation	M1356	<ul style="list-style-type: none"> <li>■ In Auto or MDI mode, when Pr485 [Enable the lock for positive/negative axis operation in AUTO mode] is set to 1 and M1356 is set to On, the A axis does not move in negative direction.</li> <li>■ In JOG, MPG, or Rapid mode, if M1356 is set to On, the A axis does not move in negative direction regardless of the parameter setting.</li> <li>■ In HOME mode, of M1356 is set to On, the A axis does not perform the homing procedure.</li> </ul>	R/W
Lock machine B axis negative operation	M1357	<ul style="list-style-type: none"> <li>■ In Auto or MDI mode, when Pr485 [Enable the lock for positive/negative axis operation in AUTO mode] is set to 1 and M1357 is set to On, the B axis does not move in negative direction.</li> <li>■ In JOG, MPG, or Rapid mode, if M1357 is set to On, the B axis does not move in negative direction regardless of the parameter setting.</li> <li>■ In HOME mode, of M1357 is set to On, the B axis does not perform the homing procedure.</li> </ul>	R/W
Lock machine C axis negative operation	M1358	<ul style="list-style-type: none"> <li>■ In Auto or MDI mode, when Pr485 [Enable the lock for positive/negative axis operation in AUTO mode] is set to 1 and M1358 is set to On, the C axis does not move in negative direction.</li> <li>■ In JOG, MPG, or Rapid mode, if M1358 is set to On, the C axis does not move in negative direction regardless of the parameter setting.</li> <li>■ In HOME mode, of M1358 is set to On, the C axis does not perform the homing procedure.</li> </ul>	R/W
Lock machine U axis negative operation	M1359	<ul style="list-style-type: none"> <li>■ In Auto or MDI mode, when Pr485 [Enable the lock for positive/negative axis operation in AUTO mode] is set to 1 and M1359 is set to On, the U axis does not move in negative direction.</li> <li>■ In JOG, MPG, or Rapid mode, if M1359 is set to On, the U axis does not move in negative direction regardless of the parameter setting.</li> <li>■ In HOME mode, of M1359 is set to On, the U axis does not perform the homing procedure.</li> </ul>	R/W
Lock machine V axis negative operation	M1360	<ul style="list-style-type: none"> <li>■ In Auto or MDI mode, when Pr485 [Enable the lock for positive/negative axis operation in AUTO mode] is set to 1 and M1360 is set to On, the V axis does not move in negative direction.</li> <li>■ In JOG, MPG, or Rapid mode, if M1360 is set to On, the V axis does not move in negative direction regardless of the parameter setting.</li> <li>■ In HOME mode, of M1360 is set to On, the V axis does not perform the homing procedure.</li> </ul>	R/W
Lock machine W axis negative operation	M1361	<ul style="list-style-type: none"> <li>■ In Auto or MDI mode, when Pr485 [Enable the lock for positive/negative axis operation in AUTO mode] is set to 1 and M1361 is set to On, the W axis does not move in negative direction.</li> <li>■ In JOG, MPG, or Rapid mode, if M1361 is set to On, the W axis does not move in negative direction regardless of the parameter setting.</li> <li>■ In HOME mode, of M1361 is set to On, the W axis does not perform the homing procedure.</li> </ul>	R/W
Trigger breakpoint search function	M1567	Triggers the breakpoint search function on the MLC.	R/W
HMI input point 1	M2080	Corresponds its status to the system variable, #1864.	R
HMI input point 2	M2081	Corresponds its status to the system variable, #1865.	R
HMI input point 3	M2082	Corresponds its status to the system variable, #1866.	R
HMI input point 4	M2083	Corresponds its status to the system variable, #1867.	R

Function name	Special M	Description	Device type
HMI input point 5	M2084	Corresponds its status to the system variable, #1868.	R
HMI input point 6	M2085	Corresponds its status to the system variable, #1869.	R
HMI input point 7	M2086	Corresponds its status to the system variable, #1870.	R
HMI input point 8	M2087	Corresponds its status to the system variable, #1871.	R
HMIe input point 9	M2088	Corresponds its status to the system variable, #1872.	R
HMI input point 10	M2089	Corresponds its status to the system variable, #1873.	R
HMI input point 11	M2090	Corresponds its status to the system variable, #1874.	R
HMI input point 12	M2091	Corresponds its status to the system variable, #1875.	R
HMI input point 13	M2092	Corresponds its status to the system variable, #1876.	R
HMI input point 14	M2093	Corresponds its status to the system variable, #1877.	R
HMI input point 15	M2094	Corresponds its status to the system variable, #1878.	R
HMI input point 16	M2095	Corresponds its status to the system variable, #1879.	R
HMI input point 17	M2096	Corresponds its status to the system variable, #1880.	R
HMI input point 18	M2097	Corresponds its status to the system variable, #1881.	R
HMI input point 19	M2098	Corresponds its status to the system variable, #1882.	R
HMI input point 20	M2099	Corresponds its status to the system variable, #1883.	R
HMI input point 21	M2100	Corresponds its status to the system variable, #1884.	R
HMI input point 22	M2101	Corresponds its status to the system variable, #1885.	R
HMI input point 23	M2102	Corresponds its status to the system variable, #1886.	R
HMI input point 24	M2103	Corresponds its status to the system variable, #1887.	R
HMI input point 25	M2104	Corresponds its status to the system variable, #1888.	R
HMI input point 26	M2105	Corresponds its status to the system variable, #1889.	R
HMI input point 27	M2106	Corresponds its status to the system variable, #1890.	R
HMI input point 28	M2107	Corresponds its status to the system variable, #1891.	R
HMI input point 29	M2108	Corresponds its status to the system variable, #1892.	R
HMI input point 30	M2109	Corresponds its status to the system variable, #1893.	R
HMI input point 31	M2110	Corresponds its status to the system variable, #1894.	R
HMI input point 32	M2111	Corresponds its status to the system variable, #1895.	R
Startup complete and system ready	M2112	This signal is sent when the NC system is ready.	R
System macro warning occurred	M2113	This signal is sent when a macro alarm (MR____) occurs on the NC system.	R
System emergency stop	M2114	This signal is sent when the EMG key is pressed, triggering the emergency stop of the system.	R
Servo enable	M2115	This signal is sent when the servo is ready.	R
MLC X axis high speed input trigger feedback	M2128	This signal is sent when M1298 (MLC X axis high speed input trigger) is set as On and the corresponding DI of the X axis is triggered.	R
MLC Y axis high speed input trigger feedback	M2129	This signal is sent when M1299 (MLC Y axis high speed input trigger) is set as On and the corresponding DI of the Y axis is triggered.	R
MLC Z axis high speed input trigger feedback	M2130	This signal is sent when M1300 (MLC Z axis high speed input trigger) is set as On and the corresponding DI of the Z axis is triggered.	R
MLC A axis high speed input trigger feedback	M2131	This signal is sent when M1301 (MLC A axis high speed input trigger) is set as On and the corresponding DI of the A axis is triggered.	R
MLC B axis high speed input trigger feedback	M2132	This signal is sent when M1302 (MLC B axis high speed input trigger) is set as On and the corresponding DI of the B axis is triggered.	R

Function name	Special M	Description	Device type
MLC C axis high speed input trigger feedback	M2133	This signal is sent when M1303 (MLC C axis high speed input trigger) is set as On and the corresponding DI of the C axis is triggered.	R
MLC U axis high speed input trigger feedback	M2134	This signal is sent when M1304 (MLC U axis high speed input trigger) is set as On and the corresponding DI of the U axis is triggered.	R
MLC V axis high speed input trigger feedback	M2135	This signal is sent when M1305 (MLC V axis high speed input trigger) is set as On and the corresponding DI of the V axis is triggered.	R
MLC W axis high speed input trigger feedback	M2136	This signal is sent when M1306 (MLC W axis high speed input trigger) is set as On and the corresponding DI of the W axis is triggered.	R
HSI 1	M2142	This signal is sent when G31P1 (high speed input contact 1) skip signal is input.	R
HSI 2	M2143	This signal is sent when G31P2 (high speed input contact 2) skip signal is input.	R
Port 1 axis positive hardware limit	M2144	This signal is sent when Port 1 axis positive hardware limit is triggered.	R
Port 1 axis negative hardware limit	M2145	This signal is sent when Port 1 axis negative hardware limit is triggered.	R
Port 1 axis home signal	M2146	This signal is sent when Port 1 axis home signal is triggered.	R
Port 2 axis positive hardware limit	M2148	This signal is sent when Port 2 axis positive hardware limit is triggered.	R
Port 2 axis negative hardware limit	M2149	This signal is sent when Port 2 axis negative hardware limit is triggered.	R
Port 2 axis home signal	M2150	This signal is sent when Port 2 axis home signal is triggered.	R
Port 3 axis positive hardware limit	M2152	This signal is sent when Port 3 axis positive hardware limit is triggered.	R
Port 3 axis negative hardware limit	M2153	This signal is sent when Port 3 axis negative hardware limit is triggered.	R
Port 3 axis home signal	M2154	This signal is sent when Port 3 axis home signal is triggered.	R
Port 4 axis positive hardware limit	M2156	This signal is sent when Port 4 axis positive hardware limit is triggered.	R
Port 4 axis negative hardware limit	M2157	This signal is sent when Port 4 axis negative hardware limit is triggered.	R
Port 4 axis home signal	M2158	This signal is sent when Port 4 axis home signal is triggered.	R
Port 5 axis positive hardware limit	M2160	This signal is sent when Port 5 axis positive hardware limit is triggered.	R
Port 5 axis negative hardware limit	M2161	This signal is sent when Port 5 axis negative hardware limit is triggered.	R
Port 5 axis home signal	M2162	This signal is sent when Port 5 axis home signal is triggered.	R
Port 6 axis positive hardware limit	M2164	This signal is sent when Port 6 axis positive hardware limit is triggered.	R
Port 6 axis negative hardware limit	M2165	This signal is sent when Port 6 axis negative hardware limit is triggered.	R
Port 6 axis home signal	M2166	This signal is sent when Port 6 axis home signal is triggered.	R
Port 7 axis positive hardware limit	M2168	This signal is sent when Port 7 axis positive hardware limit is triggered.	R
Port 7 axis negative hardware limit	M2169	This signal is sent when Port 7 axis negative hardware limit is triggered.	R



Function name	Special M	Description	Device type
Port 7 axis home signal	M2170	This signal is sent when Port 7 axis home signal is triggered.	R
Port 8 axis positive hardware limit	M2172	This signal is sent when Port 8 axis positive hardware limit is triggered.	R
Port 8 axis negative hardware limit	M2173	This signal is sent when Port 8 axis negative hardware limit is triggered.	R
Port 8 axis home signal	M2174	This signal is sent when Port 8 axis home signal is triggered.	R
Port 9 axis positive hardware limit	M2176	This signal is sent when Port 9 axis positive hardware limit is triggered.	R
Port 9 axis negative hardware limit	M2177	This signal is sent when Port 9 axis negative hardware limit is triggered.	R
Port 9 axis home signal	M2178	This signal is sent when Port 9 axis home signal is triggered.	R
M code execution	M2208	When the M code is executed in the program, the NC sets M2208 to on. Until M1152 (M, S, and T codes execution complete) is triggered, M2208 is set to off. The NC does not trigger M2208 when the program executes M00, M01, M02, M30, M98, M99, or an M code that is used for macro call.	R
S code execution	M2209	When the S code is executed in the program, the NC sets M2209 to on. Until M1152 (M, S, and T codes execution complete) is triggered, M2209 is set to off. The NC does not trigger M2209 when an S code is used for macro call.	R
T code execution	M2210	When the T code (Standby tool number) is executed in the program, the system sets M2210 to on. Until M1152 (M, S, and T codes execution complete) is triggered, M2210 is set to off. The NC does not trigger M2210 when a T code is used for macro call. M2210 is related to the station ID in the tool magazine. The NC system triggers M2210 only when the T code value is set within the specified range of tool number for the tool magazine parameter.	R
Tool magazine 1 reset complete	M2212	After you use M1171 to reset the tool magazine, the NC sets this special M relay to on. (M1171 is effective only when in AUTO or MDI mode)	R
Tool magazine 2 reset complete	M2213	After you use M1175 to reset the tool magazine, the NC sets this special M relay to on. (M1175 is effective only when in AUTO or MDI mode)	R
M96 (program interruption) in execution	M2216	When M96 (program interruption) is in execution, the NC sets this special M relay to on.	R
G code ready	M2223	After loading the G codes, the NC sets this special M relay to on.	R
Macro call initial preparation complete	M2224	Initialization setting for the macro call function is complete (only works in AUTO mode and with correct macro ID).	R
Macro call in execution	M2225	This special M is on when macro call in execution.	R
Macro call error	M2226	Indicates a macro call error.	R
Synchronous function in execution	M2227	When the synchronous function is in execution, the NC sets this special M relay to on.	R
Transfer function in execution	M2228	When the transfer function is in execution, the NC sets this special M relay to on.	R
NC system reset complete	M2229	After resetting, the NC sets this special M relay to on.	R
MPG in forward operation	M2232	This special M relay is on when the MPG is in forward operation. This special M relay is off when the MPG is in reverse operation or stationary.	R

Function name	Special M	Description	Device type
MPG in reverse operation	M2233	This special M relay is on when the MPG is in reverse operation. This special M relay is off when the MPG is in forward operation or stationary.	R
System stops at M99	M2238	When reading M99, the NC sets this special M relay to on.	R
Lathe C/S axis switching	M2239	When the lathe system is switched from Spindle mode to C axis mode, the NC sets this special M relay to on.	R
Channel alarm message	M2240	When an error occurs in the NC channel, the NC sets this special M relay to on.	R
Auto execution (AUTO)	M2241	When the NC is in AUTO mode, it sets this special M relay to on.	R
Program edit (EDIT)	M2242	When the NC is in EDIT mode, it sets this special M relay to on.	R
Manual input (MDI)	M2243	When the NC is in MDI mode, it sets this special M relay to on.	R
MPG feeding (MPG)	M2244	When the NC is in MPG mode, it sets this special M relay to on.	R
Jog (JOG)	M2245	When the NC is in JOG mode, it sets this special M relay to on.	R
Rapid feeding (RAPID)	M2246	When the NC is in RAPID mode, it sets this special M relay to on.	R
Homing (HOME)	M2247	When the NC is in HOME mode, it sets this special M relay to on.	R
Single block execution	M2249	When the program pauses after executing one single block, the NC sets this special M relay to on.	R
Program in execution	M2250	When the NC is executing the program, it sets this special M relay to on.	R
Pause	M2251	When the NC pauses, it sets this special M relay to on.	R
M01 program stop (optional)	M2252	When the NC reads M00, it sets this special M relay to on.	R
M02 end of program	M2253	When the NC reads M01, it sets this special M relay to on.	R
M30 end of program and returns	M2254	When the NC reads M02, it sets this special M relay to on.	R
M01 program stop (optional)	M2255	When the NC reads M30, it sets this special M relay to on.	R
Spindle speed reached target speed	M2256	When the spindle speed reached the target value, the NC sets this special M relay to on	R
Spindle speed reached zero speed	M2257	When the spindle speed reached zero speed, the NC sets this special M relay to on.	R
Spindle positioning complete	M2258	When the spindle reaches the target position, the NC sets this special M relay to on.	R
Spindle is in the rigid tapping mode	M2259	When the spindle performs tapping, the NC sets this special M relay to on.	R
Spindle rigid tapping interruption	M2260	When the spindle tapping is interrupted, the NC sets this special M relay to on.	R
Program ends	M2271	When the X axis homing is complete, the NC sets this special M relay to on.	R
X axis homing complete	M2272	When the Y axis homing is complete, the NC sets this special M relay to on.	R
Y axis homing complete	M2273	When the Z axis homing is complete, the NC sets this special M relay to on.	R
Z axis homing complete	M2274	When the A axis homing is complete, the NC sets this special M relay to on.	R
A axis homing complete	M2275	When the B axis homing is complete, the NC sets this special M relay to on.	R

Function name	Special M	Description	Device type
B axis homing complete	M2276	When the C axis homing is complete, the NC sets this special M relay to on.	R
C axis homing complete	M2277	When the U axis homing is complete, the NC sets this special M relay to on.	R
U axis homing complete	M2278	When the V axis homing is complete, the NC sets this special M relay to on.	R
V axis homing complete	M2279	When the W axis homing is complete, the NC sets this special M relay to on.	R
W axis homing complete	M2280	When the X axis homing is complete, the NC sets this special M relay to on.	R
X axis positioned at the 2 <sup>nd</sup> reference point	M2286	When the X axis reaches the 2 <sup>nd</sup> reference point, the NC sets this special M relay to on.	R
Y axis positioned at the 2 <sup>nd</sup> reference point	M2287	When the Y axis reaches the 2 <sup>nd</sup> reference point, the NC sets this special M relay to on.	R
Z axis positioned at the 2 <sup>nd</sup> reference point	M2288	When the Z axis reaches the 2 <sup>nd</sup> reference point, the NC sets this special M relay to on.	R
A axis positioned at the 2 <sup>nd</sup> reference point	M2289	When the A axis reaches the 2 <sup>nd</sup> reference point, the NC sets this special M relay to on.	R
B axis positioned at the 2 <sup>nd</sup> reference point	M2290	When the B axis reaches the 2 <sup>nd</sup> reference point, the NC sets this special M relay to on.	R
C axis positioned at the 2 <sup>nd</sup> reference point	M2291	When the C axis reaches the 2 <sup>nd</sup> reference point, the NC sets this special M relay to on.	R
U axis positioned at the 2 <sup>nd</sup> reference point	M2292	When the U axis reaches the 2 <sup>nd</sup> reference point, the NC sets this special M relay to on.	R
V axis positioned at the 2 <sup>nd</sup> reference point	M2293	When the V axis reaches the 2 <sup>nd</sup> reference point, the NC sets this special M relay to on.	R
W axis positioned at the 2 <sup>nd</sup> reference point	M2294	When the W axis reaches the 2 <sup>nd</sup> reference point, the NC sets this special M relay to on.	R
X axis positioned at the 3 <sup>rd</sup> reference point	M2295	When the X axis reaches the 3 <sup>rd</sup> reference point, the NC sets this special M relay to on.	R
Y axis positioned at the 3 <sup>rd</sup> reference point	M2296	When the Y axis reaches the 3 <sup>rd</sup> reference point, the NC sets this special M relay to on.	R
Z axis positioned at the 3 <sup>rd</sup> reference point	M2297	When the Z axis reaches the 3 <sup>rd</sup> reference point, the NC sets this special M relay to on.	R
A axis positioned at the 3 <sup>rd</sup> reference point	M2298	When the A axis reaches the 3 <sup>rd</sup> reference point, the NC sets this special M relay to on.	R
B axis positioned at the 3 <sup>rd</sup> reference point	M2299	When the B axis reaches the 3 <sup>rd</sup> reference point, the NC sets this special M relay to on.	R
C axis positioned at the 3 <sup>rd</sup> reference point	M2300	When the C axis reaches the 3 <sup>rd</sup> reference point, the NC sets this special M relay to on.	R
U axis positioned at the 3 <sup>rd</sup> reference point	M2301	When the U axis reaches the 3 <sup>rd</sup> reference point, the NC sets this special M relay to on.	R
V axis positioned at the 3 <sup>rd</sup> reference point	M2302	When the V axis reaches the 3 <sup>rd</sup> reference point, the NC sets this special M relay to on.	R
W axis positioned at the 3 <sup>rd</sup> reference point	M2303	When the W axis reaches the 3 <sup>rd</sup> reference point, the NC sets this special M relay to on.	R
MLC X axis positioning complete	M2304	When the X axis is in MLC axis control mode and X axis reaches the positioning point, the NC sets this special M relay to on. If the MLC is in speed mode, M2304 indicates the speed is reached.	R
MLC Y axis positioning complete	M2305	When the Y axis is in MLC axis control mode and Y axis reaches the positioning point, the NC sets this special M relay to on. If the MLC is in speed mode, M2305 indicates the speed is reached.	R

Function name	Special M	Description	Device type
MLC Z axis positioning complete	M2306	When the Z axis is in MLC axis control mode and Z axis reaches the positioning point, the NC sets this special M relay to on. If the MLC is in speed mode, M2306 indicates the speed is reached.	R
MLC A axis positioning complete	M2307	When the A axis is in MLC axis control mode and A axis reaches the positioning point, the NC sets this special M relay to on. If the MLC is in speed mode, M2307 indicates the speed is reached.	R
MLC B axis positioning complete	M2308	When the B axis is in MLC axis control mode and B axis reaches the positioning point, the NC sets this special M relay to on. If the MLC is in speed mode, M2308 indicates the speed is reached.	R
MLC C axis positioning complete	M2309	When the C axis is in MLC axis control mode and C axis reaches the positioning point, the NC sets this special M relay to on. If the MLC is in speed mode, M2309 indicates the speed is reached.	R
MLC U axis positioning complete	M2310	When the U axis is in MLC axis control mode and U axis reaches the positioning point, the NC sets this special M relay to on. If the MLC is in speed mode, M2310 indicates the speed is reached.	R
MLC V axis positioning complete	M2311	When the V axis is in MLC axis control mode and V axis reaches the positioning point, the NC sets this special M relay to on. If the MLC is in speed mode, M2311 indicates the speed is reached.	R
MLC W axis positioning complete	M2312	When the W axis is in MLC axis control mode and W axis reaches the positioning point, the NC sets this special M relay to on. If the MLC is in speed mode, M2312 indicates the speed is reached.	R
X axis moving	M2320	When X axis is moving (in any modes), the NC sets this special M relay to on.	R
Y axis moving	M2321	When Y axis is moving (in any modes), the NC sets this special M relay to on.	R
Z axis moving	M2322	When Z axis is moving (in any modes), the NC sets this special M relay to on.	R
A axis moving	M2323	When A axis is moving (in any modes), the NC sets this special M relay to on.	R
B axis moving	M2324	When B axis is moving (in any modes), the NC sets this special M relay to on.	R
C axis moving	M2325	When C axis is moving (in any modes), the NC sets this special M relay to on.	R
U axis moving	M2326	When U axis is moving (in any modes), the NC sets this special M relay to on.	R
V axis moving	M2327	When V axis is moving (in any modes), the NC sets this special M relay to on.	R
W axis moving	M2328	When W axis is moving (in any modes), the NC sets this special M relay to on.	R
X axis is moving in forward direction	M2336	This special M relay is on when X axis is moving in forward direction.	R
Y axis is moving in forward direction	M2337	This special M relay is on when Y axis is moving in forward direction.	R
Z axis is moving in forward direction	M2338	This special M relay is on when Z axis is moving in forward direction.	R
A axis is moving in forward direction	M2339	This special M relay is on when A axis is moving in forward direction.	R
B axis is moving in forward direction	M2340	This special M relay is on when B axis is moving in forward direction.	R
C axis is moving in forward direction	M2341	This special M relay is on when C axis is moving in forward direction.	R

Function name	Special M	Description	Device type
U axis is moving in forward direction	M2342	This special M relay is on when U axis is moving in forward direction.	R
V axis is moving in forward direction	M2343	This special M relay is on when V axis is moving in forward direction.	R
W axis is moving in forward direction	M2344	This special M relay is on when W axis is moving in forward direction.	R
X axis is moving in reverse direction	M2345	This special M relay is on when X axis is moving in reverse direction.	R
Y axis is moving in reverse direction	M2346	This special M relay is on when Y axis is moving in reverse direction.	R
Z axis is moving in reverse direction	M2347	This special M relay is on when Z axis is moving in reverse direction.	R
A axis is moving in reverse direction	M2348	This special M relay is on when A axis is moving in reverse direction.	R
B axis is moving in reverse direction	M2349	This special M relay is on when B axis is moving in reverse direction.	R
C axis is moving in reverse direction	M2350	This special M relay is on when C axis is moving in reverse direction.	R
U axis is moving in reverse direction	M2351	This special M relay is on when U axis is moving in reverse direction.	R
V axis is moving in reverse direction	M2352	This special M relay is on when V axis is moving in reverse direction.	R
W axis is moving in reverse direction	M2353	This special M relay is on when W axis is moving in reverse direction.	R
NC / MLC axis switching complete (X axis)	M2354	When the NC sets M1200 to on to switch X axis from NC to MLC, the NC sets this special M relay to on.	R
NC / MLC axis switching complete (Y axis)	M2355	When the NC sets M1201 to on to switch Y axis from NC to MLC, the NC sets this special M relay to on.	R
NC / MLC axis switching complete (Z axis)	M2356	When the NC sets M1202 to on to switch Z axis from NC to MLC, the NC sets this special M relay to on.	R
NC / MLC axis switching complete (A axis)	M2357	When the NC sets M1203 to on to switch A axis from NC to MLC, the NC sets this special M relay to on.	R
NC / MLC axis switching complete (B axis)	M2358	When the NC sets M1204 to on to switch B axis from NC to MLC, the NC sets this special M relay to on.	R
NC / MLC axis switching complete (C axis)	M2359	When the NC sets M1205 to on to switch C axis from NC to MLC, the NC sets this special M relay to on.	R
NC / MLC axis switching complete (U axis)	M2360	When the NC sets M1206 to on to switch U axis from NC to MLC, the NC sets this special M relay to on.	R
NC / MLC axis switching complete (V axis)	M2361	When the NC sets M1207 to on to switch V axis from NC to MLC, the NC sets this special M relay to on.	R
NC / MLC axis switching complete (W axis)	M2362	When the NC sets M1208 to on to switch W axis from NC to MLC, the NC sets this special M relay to on.	R
X axis positioned at the 4 <sup>th</sup> reference point	M2368	When the X axis reaches the 4 <sup>th</sup> reference point, the NC sets this special M relay to on.	R
Y axis positioned at the 4 <sup>th</sup> reference point	M2369	When the Y axis reaches the 4 <sup>th</sup> reference point, the NC sets this special M relay to on.	R
Z axis positioned at the 4 <sup>th</sup> reference point	M2370	When the Z axis reaches the 4 <sup>th</sup> reference point, the NC sets this special M relay to on.	R

Function name	Special M	Description	Device type
A axis positioned at the 4 <sup>th</sup> reference point	M2371	When the A axis reaches the 4 <sup>th</sup> reference point, the NC sets this special M relay to on.	R
B axis positioned at the 4 <sup>th</sup> reference point	M2372	When the B axis reaches the 4 <sup>th</sup> reference point, the NC sets this special M relay to on.	R
C axis positioned at the 4 <sup>th</sup> reference point	M2373	When the C axis reaches the 4 <sup>th</sup> reference point, the NC sets this special M relay to on.	R
U axis positioned at the 4 <sup>th</sup> reference point	M2374	When the U axis reaches the 4 <sup>th</sup> reference point, the NC sets this special M relay to on.	R
V axis positioned at the 4 <sup>th</sup> reference point	M2375	When the V axis reaches the 4 <sup>th</sup> reference point, the NC sets this special M relay to on.	R
W axis positioned at the 4 <sup>th</sup> reference point	M2376	When the W axis reaches the 4 <sup>th</sup> reference point, the NC sets this special M relay to on.	R
X axis homing complete	M2377	When the X axis origin coordinate is established, the "Homing complete" symbol ( ) is displayed in the POS screen, and the NC sets this special M relay to on.	R
Y axis homing complete	M2378	When the Y axis origin coordinate is established, the "Homing complete" symbol is displayed in the POS screen, and the NC sets this special M relay to on.	R
Z axis homing complete	M2379	When the Z axis origin coordinate is established, the "Homing complete" symbol is displayed in the POS screen, and the NC sets this special M relay to on.	R
A axis homing complete	M2380	When the A axis origin coordinate is established, the "Homing complete" symbol is displayed in the POS screen, and the NC sets this special M relay to on.	R
B axis homing complete	M2381	When the B axis origin coordinate is established, the "Homing complete" symbol is displayed in the POS screen, and the NC sets this special M relay to on.	R
C axis homing complete	M2382	When the C axis origin coordinate is established, the "Homing complete" symbol is displayed in the POS screen, and the NC sets this special M relay to on.	R
U axis homing complete	M2383	When the U axis origin coordinate is established, the "Homing complete" symbol is displayed in the POS screen, and the NC sets this special M relay to on.	R
V axis homing complete	M2384	When the V axis origin coordinate is established, the "Homing complete" symbol is displayed in the POS screen, and the NC sets this special M relay to on.	R
W axis homing complete	M2385	When the W axis origin coordinate is established, the "Homing complete" symbol is displayed in the POS screen, and the NC sets this special M relay to on.	R
X axis Servo On / Off status	M2386	When X axis is in Servo On status, the NC sets this special M relay to on.	R
Y axis Servo On / Off status	M2387	When Y axis is in Servo On status, the NC sets this special M relay to on.	R
Z axis Servo On / Off status	M2388	When Z axis is in Servo On status, the NC sets this special M relay to on.	R
A axis Servo On / Off status	M2389	When A axis is in Servo On status, the NC sets this special M relay to on.	R
B axis Servo On / Off status	M2390	When B axis is in Servo On status, the NC sets this special M relay to on.	R
C axis Servo On / Off status	M2391	When C axis is in Servo On status, the NC sets this special M relay to on.	R
U axis Servo On / Off status	M2392	When U axis is in Servo On status, the NC sets this special M relay to on.	R
V axis Servo On / Off status	M2393	When V axis is in Servo On status, the NC sets this special M relay to on.	R
W axis Servo On / Off status	M2394	When W axis is in Servo On status, the NC sets this special M relay to on.	R

Function name	Special M	Description	Device type
Movement in X axis	M2400	When Pr501 (Axis movement protection) is set to 1, if the X axis moves during machining, the NC sets the corresponding special M relay to on.	R
Movement in Y axis	M2401	When Pr501 (Axis movement protection) is set to 1, if the Y axis moves during machining, the NC sets the corresponding special M relay to on.	R
Movement in Z axis	M2402	When Pr501 (Axis movement protection) is set to 1, if the Z axis moves during machining, the NC sets the corresponding special M relay to on.	R
Movement in A axis	M2403	When Pr501 (Axis movement protection) is set to 1, if the A axis moves during machining, the NC sets the corresponding special M relay to on.	R
Movement in B axis	M2404	When Pr501 (Axis movement protection) is set to 1, if the B axis moves during machining, the NC sets the corresponding special M relay to on.	R
Movement in C axis	M2405	When Pr501 (Axis movement protection) is set to 1, if the C axis moves during machining, the NC sets the corresponding special M relay to on.	R
Movement in U axis	M2406	When Pr501 (Axis movement protection) is set to 1, if the U axis moves during machining, the NC sets the corresponding special M relay to on.	R
Movement in V axis	M2407	When Pr501 (Axis movement protection) is set to 1, if the V axis moves during machining, the NC sets the corresponding special M relay to on.	R
Movement in W axis	M2408	When Pr501 (Axis movement protection) is set to 1, if the W axis moves during machining, the NC sets the corresponding special M relay to on.	R
MLC instruction operation result is 0	M2824	If the operation result is 0 when the MLC executes the ADD, DADD, FADD, SUB, DSUB, FSUB, FMUL, FDIV, FINT, FDOT, FRAD, and FDEG instructions, the NC sets this special M relay to on.	R
MLC instruction borrow operation	M2825	If the operation result is smaller than -32,768 when the MLC executes the ADD and SUB instructions, the NC sets this special M relay to on to indicate a borrow. If the operation result is smaller than -2,147,483,648 when the MLC executes the DADD and DSUB instructions, the NC sets this special M relay to on to indicate a borrow.	R
MLC instruction carry operation	M2826	If the operation result is greater than 32,767 when the MLC executes the ADD and SUB instructions, the NC sets this special M relay to on to indicate a carry. If the operation result is greater than 2,147,483,647 when the MLC executes the DADD and DSUB instructions, the NC sets this special M relay to on to indicate a carry.	R
MLC instruction operation error	M2828	If the dividend is 0 when the MLC executes the DIV, DDIV, and FDIV instructions, the NC sets this special M relay to on. If the conversion range exceeds K0 - K9,999 when the MLC executes the BCD instruction, the NC sets this special M relay to on. If the conversion range exceeds K0 - K99,999,999 when the MLC executes the DBCD instruction, the NC sets this special M relay to on.	R
DMCNET connection status - Station 1	M2864	DMCNET connection status: successful = 1; failed = 0	R
DMCNET connection status - Station 2	M2865	DMCNET connection status: successful = 1; failed = 0	R
DMCNET connection status - Station 3	M2866	DMCNET connection status: successful = 1; failed = 0	R
DMCNET connection status - Station 4	M2867	DMCNET connection status: successful = 1; failed = 0	R

Function name	Special M	Description	Device type
DMCNET connection status - Station 5	M2868	DMCNET connection status: successful = 1; failed = 0	R
DMCNET connection status - Station 6	M2869	DMCNET connection status: successful = 1; failed = 0	R
DMCNET connection status - Station 7	M2870	DMCNET connection status: successful = 1; failed = 0	R
DMCNET connection status - Station 8	M2871	DMCNET connection status: successful = 1; failed = 0	R
DMCNET connection status - Station 9	M2872	DMCNET connection status: successful = 1; failed = 0	R
DMCNET connection status - Station 10	M2873	DMCNET connection status: successful = 1; failed = 0	R
DMCNET connection status - Station 11	M2874	DMCNET connection status: successful = 1; failed = 0	R
DMCNET connection status - Station 12	M2875	DMCNET connection status: successful = 1; failed = 0	R
IX00 interrupt input	M2880	When this special M relay is set on, the IX00 interrupt input function is enabled. Input point: X0 of the controller mainboard I/O.	R/W
IX01 interrupt input	M2881	When this special M relay is set on, the IX01 interrupt input function is enabled. Input point: X1 of the controller mainboard I/O.	R/W
IX02 interrupt input	M2882	When this special M relay is set on, the IX02 interrupt input function is enabled. Input point: X2 of the controller mainboard I/O.	R/W
IX03 interrupt input	M2883	When this special M relay is set on, the IX03 interrupt input function is enabled. Input point: X3 of the controller mainboard I/O.	R/W
IX04 interrupt input	M2884	When this special M relay is set on, the IX04 interrupt input function is enabled. Input point: X4 of the controller mainboard I/O.	R/W
IX05 interrupt input	M2885	When this special M relay is set on, the IX05 interrupt input function is enabled. Input point: X5 of the controller mainboard I/O.	R/W
IX06 interrupt input	M2886	When this special M relay is set on, the IX06 interrupt input function is enabled. Input point: X6 of the controller mainboard I/O.	R/W
IX07 interrupt input	M2887	When this special M relay is set on, the IX07 interrupt input function is enabled. Input point: X7 of the controller mainboard I/O.	R/W
IC00 interrupt input	M2888	When this special M relay is set to on, the IC00 interrupt input function is enabled. Input point: hardware high-speed input counting point 0.	R/W
IC01 interrupt input	M2889	When this special M relay is set to on, the IC01 interrupt input function is enabled. Input point: hardware high-speed input counting point 1.	R/W
IR00 interrupt input	M2896	When this special M relay is set to on, the IR00 interrupt input function is enabled. Input point: X0 of the 0 <sup>th</sup> RIO card.	R/W
IR01 interrupt input	M2897	When this special M relay is set to on, the IR01 interrupt input function is enabled. Input point: X1 of the 0 <sup>th</sup> RIO card.	R/W
IR02 interrupt input	M2898	When this special M relay is set to on, the IR02 interrupt input function is enabled. Input point: X2 of the 0 <sup>th</sup> RIO card.	R/W



Function name	Special M	Description	Device type
IR03 interrupt input	M2899	When this special M relay is set to on, the IR03 interrupt input function is enabled. Input point: X3 of the 0 <sup>th</sup> RIO card.	R/W
IR04 interrupt input	M2900	When this special M relay is set to on, the IR04 interrupt input function is enabled. Input point: X4 of the 0 <sup>th</sup> RIO card.	R/W
IR05 interrupt input	M2901	When this special M relay is set to on, the IR05 interrupt input function is enabled. Input point: X5 of the 0 <sup>th</sup> RIO card.	R/W
IR06 interrupt input	M2902	When this special M relay is set to on, the IR06 interrupt input function is enabled. Input point: X6 of the 0 <sup>th</sup> RIO card.	R/W
IR07 interrupt input	M2903	When this special M relay is set to on, the IR07 interrupt input function is enabled. Input point: X7 of the 0 <sup>th</sup> RIO card.	R/W
IR08 interrupt input	M2904	When this special M relay is set to on, the IR08 interrupt input function is enabled. Input point: X8 of the 0 <sup>th</sup> RIO card.	R/W
IR09 interrupt input	M2905	When this special M relay is set to on, the IR09 interrupt input function is enabled. Input point: X9 of the 0 <sup>th</sup> RIO card.	R/W
IR10 interrupt input	M2906	When this special M relay is set to on, the IR10 interrupt input function is enabled. Input point: X10 of the 0 <sup>th</sup> RIO card.	R/W
IR11 interrupt input	M2907	When this special M relay is set to on, the IR11 interrupt input function is enabled. Input point: X11 of the 0 <sup>th</sup> RIO card.	R/W
IR12 interrupt input	M2908	When this special M relay is set to on, the IR12 interrupt input function is enabled. Input point: X12 of the 0 <sup>th</sup> RIO card.	R/W
IR13 interrupt input	M2909	When this special M relay is set to on, the IR13 interrupt input function is enabled. Input point: X13 of the 0 <sup>th</sup> RIO card.	R/W
IR14 interrupt input	M2910	When this special M relay is set to on, the IR14 interrupt input function is enabled. Input point: X14 of the 0 <sup>th</sup> RIO card.	R/W
IR15 interrupt input	M2911	When this special M relay is set to on, the IR15 interrupt input function is enabled. Input point: X15 of the 0 <sup>th</sup> RIO card.	R/W
IR16 interrupt input	M2912	When this special M relay is set to on, the IR16 interrupt input function is enabled. Input point: X16 of the 0 <sup>th</sup> RIO card.	R/W
IR17 interrupt input	M2913	When this special M relay is set to on, the IR17 interrupt input function is enabled. Input point: X17 of the 0 <sup>th</sup> RIO card.	R/W
IR18 interrupt input	M2914	When this special M relay is set to on, the IR18 interrupt input function is enabled. Input point: X18 of the 0 <sup>th</sup> RIO card.	R/W
IR19 interrupt input	M2915	When this special M relay is set to on, the IR19 interrupt input function is enabled. Input point: X19 of the 0 <sup>th</sup> RIO card.	R/W
IR20 interrupt input	M2916	When this special M relay is set to on, the IR20 interrupt input function is enabled. Input point: X20 of the 0 <sup>th</sup> RIO card.	R/W

Function name	Special M	Description	Device type
IR21 interrupt input	M2917	When this special M relay is set to on, the IR21 interrupt input function is enabled. Input point: X21 of the 0 <sup>th</sup> RIO card.	R/W
IR22 interrupt input	M2918	When this special M relay is set to on, the IR22 interrupt input function is enabled. Input point: X22 of the 0 <sup>th</sup> RIO card.	R/W
IR23 interrupt input	M2919	When this special M relay is set to on, the IR23 interrupt input function is enabled. Input point: X23 of the 0 <sup>th</sup> RIO card.	R/W
IR24 interrupt input	M2920	When this special M relay is set to on, the IR24 interrupt input function is enabled. Input point: X24 of the 0 <sup>th</sup> RIO card.	R/W
IR25 interrupt input	M2921	When this special M relay is set to on, the IR25 interrupt input function is enabled. Input point: X25 of the 0 <sup>th</sup> RIO card.	R/W
IR26 interrupt input	M2922	When this special M relay is set to on, the IR26 interrupt input function is enabled. Input point: X26 of the 0 <sup>th</sup> RIO card.	R/W
IR27 interrupt input	M2923	When this special M relay is set to on, the IR27 interrupt input function is enabled. Input point: X27 of the 0 <sup>th</sup> RIO card.	R/W
IR28 interrupt input	M2924	When this special M relay is set to on, the IR28 interrupt input function is enabled. Input point: X28 of the 0 <sup>th</sup> RIO card.	R/W
IR29 interrupt input	M2925	When this special M relay is set to on, the IR29 interrupt input function is enabled. Input point: X29 of the 0 <sup>th</sup> RIO card.	R/W
IR30 interrupt input	M2926	When this special M relay is set to on, the IR30 interrupt input function is enabled. Input point: X30 of the 0 <sup>th</sup> RIO card.	R/W
IR31 interrupt input	M2927	When this special M relay is set to on, the IR31 interrupt input function is enabled. Input point: X31 of the 0 <sup>th</sup> RIO card.	R/W
Lock user permission	M2934	Function to use special M to lock SCP. It must be used with setting parameter Pr10015 [Account permission activation method] as 1 in order to use this special M function.	R/W
Restrict program editing	M2935	Restricts program editing in the controller.	R/W
DCNT counter C64 counts down	M2944	When this special M relay is set to on, the counter decrements by 1 every time it is triggered.	R/W
DCNT counter C65 counts down	M2945	When this special M relay is set to on, the counter decrements by 1 every time it is triggered.	R/W
DCNT counter C66 counts down	M2946	When this special M relay is set to on, the counter decrements by 1 every time it is triggered.	R/W
DCNT counter C67 counts down	M2947	When this special M relay is set to on, the counter decrements by 1 every time it is triggered.	R/W
DCNT counter C68 counts down	M2948	When this special M relay is set to on, the counter decrements by 1 every time it is triggered.	R/W
DCNT counter C69 counts down	M2949	When this special M relay is set to on, the counter decrements by 1 every time it is triggered.	R/W
DCNT counter C70 counts down	M2950	When this special M relay is set to on, the counter decrements by 1 every time it is triggered.	R/W
DCNT counter C71 counts down	M2951	When this special M relay is set to on, the counter decrements by 1 every time it is triggered.	R/W

Function name	Special M	Description	Device type
DCNT counter C72 counts down	M2952	When this special M relay is set to on, the counter decrements by 1 every time it is triggered.	R/W
DCNT counter C73 counts down	M2953	When this special M relay is set to on, the counter decrements by 1 every time it is triggered.	R/W
DCNT counter C74 counts down	M2954	When this special M relay is set to on, the counter decrements by 1 every time it is triggered.	R/W
DCNT counter C75 counts down	M2955	When this special M relay is set to on, the counter decrements by 1 every time it is triggered.	R/W
DCNT counter C76 counts down	M2956	When this special M relay is set to on, the counter decrements by 1 every time it is triggered.	R/W
DCNT counter C77 counts down	M2957	When this special M relay is set to on, the counter decrements by 1 every time it is triggered.	R/W
File queue auto processing	M2980	In AUTO mode, the system automatically executes the next program in the FILE QUEUE list when this special M relay is triggered.	R/W
G00 teaching triggered	M2992	When G00 teaching is used, the NC sets this special M relay to on.	R
G01 teaching triggered	M2993	When G01 teaching is used, the NC sets this special M relay to on.	R
G00 teaching record complete	M2994	When G00 teaching is used and the motion path is recorded, the special M relay is on.	R
G01 teaching record complete	M2995	When G01 teaching is used and the motion path is recorded, the special M relay is on.	R

### 14.3 Special D summary table

Function name	Special D	Description	Device type
Number of the processing complete pieces (32-bit)	D1018	It can be set from the Process screen or written by the MLC. You can use Pr10015 [Machining count display format] to determine which special D will be the display source. D1019 is the high-order position of the 32 bits. Pr10015 [Machining count display format] = 0: uses D1022 and D1023 as the display source. Pr10015 [Machining count display format] = 1: uses D1018 (D1019) and D1020 (D1021) as the display source.	R/W
Target number of the processing pieces (32-bit)	D1020	It can be set from the Process screen or written by MLC. D1021 is the higher order position of the 32 bits.	R/W
Number of the processing complete pieces	D1022	It can be set from the Process screen or written by MLC.	R/W
Target number of the processing pieces	D1023	It can be set from the Process screen or written by MLC.	R/W
HMI output point 1	D1024	Corresponds its status to the system variable, #1833.	R/W
HMI output point 2	D1025	Corresponds its status to the system variable, #1834.	R/W
HMI output point 3	D1026	Corresponds its status to the system variable, #1835.	R/W
HMI output point 4	D1027	Corresponds its status to the system variable, #1836.	R/W
HMI output point 5	D1028	Corresponds its status to the system variable, #1837.	R/W
HMI output point 6	D1029	Corresponds its status to the system variable, #1838.	R/W
HMI output point 7	D1030	Corresponds its status to the system variable, #1839.	R/W
HMI output point 8	D1031	Corresponds its status to the system variable, #1840.	R/W
HMI output point 9	D1032	Corresponds its status to the system variable, #1841.	R/W
HMI output point 10	D1033	Corresponds its status to the system variable, #1842.	R/W
HMI output point 11	D1034	Corresponds its status to the system variable, #1843.	R/W
HMI output point 12	D1035	Corresponds its status to the system variable, #1844.	R/W
HMI output point 13	D1036	Corresponds its status to the system variable, #1845.	R/W
HMI output point 14	D1037	Corresponds its status to the system variable, #1846.	R/W
HMI output point 15	D1038	Corresponds its status to the system variable, #1847.	R/W
HMI output point 16	D1039	Corresponds its status to the system variable, #1848.	R/W
MPG operation mode number	D1040	Sets the MPG operation mode. Set D1040 to 0 to use the external MPG. Set D1040 to 10 to use the keys on the machine operation panel B as the MPG function, with the pulse control trigger flags of M1118 and M1119.	R/W
MPG operation channel setting	D1041	Specifies the channel for MPG operation; the default value is 0.	R/W
MPG pulse magnification	D1042	The x1, x10 and x100 setting for MPG pulse magnification. Uses the smallest moving unit 0.001 mm to multiply by the magnification; for example 1 x 0.001 = 0.001 mm/cnt.	R/W
MPG axis selection status	D1043	The axis for moving operation can be switched with the MPG. Set 0 for X axis, 1 for Y axis, 2 for Z axis, 3 for A axis, and 4 for B axis.	R/W
DMCNET Ready for HMI	D1048	When the system is ready, it converts the binary format to decimal format to display the number of DMCNET axes that are connected successfully. Example: when the number of successfully connected axes is 4, its binary format display is 1111 and it is converted and displayed as decimal format, 15.	R

Function name	Special D	Description	Device type
Cutting feed rate adjustment	D1056	Sets the percentage of the cutting feedrate (F) in the NC program. Example: If you set F to 1000 and the current value of D1056 is 50, it means the actual command speed is 500 mm/min (= 1000 x 50%).	R/W
Rapid movement speed adjustment	D1058	Sets the percentage of G00's speed (rapid movement). Example: If the rapid movement speed is 6000, and D1058 is set to 50, it means the actual speed of G00 is 3000 mm/min (= 6000 x 50%).	R/W
Spindle speed adjustment	D1060	Sets the percentage for the S value specified in the NC program. Example: If S1000 is given in the program and D1060 is set to 30, it means the actual spindle speed is 300 rpm (= 1000 x 30%).	R/W
Speed setting for jog feeding and dry run speed	D1062	Sets movement speed F for dry run in JOG or AUTO mode. If you set D1062 to 50, it indicates F50 (mm/min) with the range of 0 - 65535 mm/min.	R/W
X axis positioning command (MLC axis)	D1064	Specifies the moving distance of the MLC X axis. Unit: mm, inch. This is a 32-bit special D.	R/W
Y axis positioning command (MLC axis)	D1066	Specifies the moving distance of the MLC Y axis. Unit: mm, inch. This is a 32-bit special D.	R/W
Z axis positioning command (MLC axis)	D1068	Specifies the moving distance of the MLC Z axis. Unit: mm, inch. This is a 32-bit special D.	R/W
A axis positioning command (MLC axis)	D1070	Specifies the moving distance of the MLC A axis. Unit: mm, inch. This is a 32-bit special D.	R/W
B axis positioning command (MLC axis)	D1072	Specifies the moving distance of the MLC B axis. Unit: mm, inch. This is a 32-bit special D.	R/W
C axis positioning command (MLC axis)	D1074	Specifies the moving distance of the MLC C axis. Unit: mm, inch. This is a 32-bit special D.	R/W
U axis positioning command (MLC axis)	D1076	Specifies the moving distance of the MLC U axis. Unit: mm, inch. This is a 32-bit special D.	R/W
V axis positioning command (MLC axis)	D1078	Specifies the moving distance of the MLC V axis. Unit: mm, inch. This is a 32-bit special D.	R/W
W axis positioning command (MLC axis)	D1080	Specifies the moving distance of the MLC W axis. Unit: mm, inch. This is a 32-bit special D.	R/W
X axis positioning speed (MLC axis)	D1082	Specifies the moving speed of the MLC X axis. Unit: mm, inch/min. This is a 32-bit special D.	R/W
Y axis positioning speed (MLC axis)	D1084	Specifies the moving speed of the MLC Y axis. Unit: mm, inch/min. This is a 32-bit special D.	R/W
Z axis positioning speed (MLC axis)	D1086	Specifies the moving speed of the MLC Z axis. Unit: mm, inch/min. This is a 32-bit special D.	R/W
A axis positioning speed (MLC axis)	D1088	Specifies the moving speed of the MLC A axis. Unit: refers to Pr634 [Rotation axis unit selection]. This is a 32-bit special D.	R/W

Function name	Special D	Description	Device type
B axis positioning speed (MLC axis)	D1090	Specifies the moving speed of the MLC B axis. Unit: refers to Pr634 [Rotation axis unit selection]. This is a 32-bit special D.	R/W
C axis positioning speed (MLC axis)	D1092	Specifies the moving speed of the MLC C axis. Unit: refers to Pr634 [Rotation axis unit selection]. This is a 32-bit special D.	R/W
U axis positioning speed (MLC axis)	D1094	Specifies the moving speed of the MLC U axis. Unit: refers to Pr634 [Rotation axis unit selection]. This is a 32-bit special D.	R/W
V axis positioning speed (MLC axis)	D1096	Specifies the moving speed of the MLC V axis. Unit: refers to Pr634 [Rotation axis unit selection]. This is a 32-bit special D.	R/W
W axis positioning speed (MLC axis)	D1098	Specifies the moving speed of the MLC W axis. Unit: refers to Pr634 [Rotation axis unit selection]. This is a 32-bit special D.	R/W
Spindle positioning speed (MLC axis)	D1100	Specifies the moving speed of the MLC spindle. Unit: rpm. This is a 32-bit special D.	R/W
Main file name	D1102	When Pr12017 [D device record system information] is set as 1, D1102 records the last used O0000 - O9999 main file name.	R
Total machining time	D1103	When Pr12017 [D device record system information] is set as 1, D1103 records the total machining time in the unit of seconds. Unit: seconds. This is a 32-bit special D.	R
Single machining time	D1105	When Pr12017 [D device record system information] is set as 1, D1105 records the single machining time in the unit of seconds. Unit: seconds. This is a 32-bit special D.	R
System time: Year, month	D1107	When Pr12017 [D device record system information] is set as 1, D1107 records the system time's year and month.	R
System time: Day, hour	D1108	When Pr12017 [D device record system information] is set as 1, D1108 records the system time's day and hour.	R
System time: Minute, second	D1109	When Pr12017 [D device record system information] is set as 1, D1109 records the system time's minute and second.	R
Macro call file name	D1111	Specifies the macro call file name O9xxx. Example: When K9100 is written into D1111, the system calls the macro program O9100.	R/W
Spindle analog voltage output Port 2	D1114	When the spindle is DMCNET bus mode, you can use this special D to output analog voltage. Value input range: -1000 to +1000. Unit: 0.01V. This special D is only supported on the B series.	R/W
Lathe tool number selection	D1115	When the lathe parameter Pr308 [Tool number display source] = 1, the lathe tool number selection is controlled by this special D. Range: 0 to 65535.	R/W
Spindle analog voltage output Port 1	D1125	When the spindle is DMCNET bus mode, this special D can be used to output analog voltage. Value input range: -1000 to +1000. Unit: 0.01V.	R/W
Equi-slope filter compensation for X axis	D1126	The X axis filter compensation value following the slope. Unit: mm	R/W
Equi-slope filter compensation for Y axis	D1128	The Y axis filter compensation value following the slope. Unit: mm	R/W
Equi-slope filter compensation for Z axis	D1130	The Z axis filter compensation value following the slope. Unit: mm	R/W

Function name	Special D	Description	Device type
Equi-slope filter compensation for A axis	D1132	The A axis filter compensation value following the slope. Unit: mm or deg	R/W
Equi-slope filter compensation for B axis	D1134	The B axis filter compensation value following the slope. Unit: mm or deg	R/W
Equi-slope filter compensation for C axis	D1136	The C axis filter compensation value following the slope. Unit: mm or deg	R/W
Equi-slope filter compensation for U axis	D1138	The U axis filter compensation value following the slope. Unit: mm or deg	R/W
Equi-slope filter compensation for V axis	D1140	The V axis filter compensation value following the slope. Unit: mm or deg	R/W
Equi-slope filter compensation for W axis	D1142	The W axis filter compensation value following the slope. Unit: mm or deg	R/W
Linear axis compensation speed	D1144	Linear axis compensation speed value following the slope. Unit: mm/sec	R/W
Rotation axis compensation speed	D1146	Rotation axis compensation speed value. Unit: deg/sec	R/W
Spindle speed (written with special D register)	D1148	You can write the spindle speed with D1148. (Must be used with special M1307).	R/W
Arc preview speed	D1150	Adjusts the preview speed of the arc block during machining preview. This is a 32-bit special D.	R/W
Spindle tool number (Written with special D)	D1172	You can write spindle tool number with D1172. (Set Pr308 [Tool number display source] = 1.)	R/W
Standby tool number (Written with special D)	D1173	You can write the standby tool number with D1173. (Set Pr308 [Tool number display source] = 1.)	R/W
Command tool number (Written with special D)	D1174	You can write the command tool number with D1174. (Set Pr308 [Tool number display source] = 1.)	R/W
HMI input point 1	D1336	Corresponds to the system variable #1896. You can use #1896 to assign the value of D1336.	R
HMI input point 2	D1337	Corresponds to the system variable #1897. You can use #1897 to assign the value of D1337.	R
HMI input point 3	D1338	Corresponds to the system variable #1898. You can use #1898 to assign the value of D1338.	R
HMI input point 4	D1339	Corresponds to the system variable #1899. You can use #1899 to assign the value of D1339.	R
HMI input point 5	D1340	Corresponds to the system variable #1900. You can use #1900 to assign the value of D1340.	R
HMI input point 6	D1341	Corresponds to the system variable #1901. You can use #1901 to assign the value of D1341.	R
HMI input point 7	D1342	Corresponds to the system variable #1902. You can use #1902 to assign the value of D1342.	R

Function name	Special D	Description	Device type
HMI input point 8	D1343	Corresponds to the system variable #1903. You can use #1903 to assign the value of D1343.	R
HMI input point 9	D1344	Corresponds to the system variable #1904. You can use #1904 to assign the value of D1344.	R
HMI input point 10	D1345	Corresponds to the system variable #1905. You can use #1905 to assign the value of D1345.	R
HMI input point 11	D1346	Corresponds to the system variable #1906. You can use #1906 to assign the value of D1346.	R
HMI input point 12	D1347	Corresponds to the system variable #1907. You can use #1907 to assign the value of D1347.	R
HMI input point 13	D1348	Corresponds to the system variable #1908. You can use #1908 to assign the value of D1348.	R
HMI input point 14	D1349	Corresponds to the system variable #1909. You can use #1909 to assign the value of D1349.	R
HMI input point 15	D1350	Corresponds to the system variable #1910. You can use #1910 to assign the value of D1350.	R
HMI input point 16	D1351	Corresponds to the system variable #1911. You can use #1911 to assign the value of D1351.	R
Spindle command speed (32-bit)	D1364	When the program runs to an S code, it corresponds the S code value to the D1369 and D1364 registers. If the spindle command speed exceeds 16 bits, the MLC refers to D1364 for the speed value. Unit: rpm. This is a 32-bit special D.	R
M code data	D1368	When the program runs to an M code, it corresponds the M code value to the D1368 register. When the M code macro call is executed, the value of this special D register remains unchanged. These M codes do not include M00, M01, M02, M30, M98 and M99.	R
S code data	D1369	When the program runs to an S code, it corresponds the S code value to the D1369 register. When the S code macro call is executed, the value of this special D register remains unchanged.	R
T code data (command)	D1370	When the program runs to a T code, it corresponds the T code value to the D1370 register. When the T code macro call is executed, the value of this special D register remains unchanged. This data is related to the setting of tool magazine station numbers. The assigned T code value in the program must be within the range of the tool magazine parameter (Pr338), so this T code data can be displayed.	R
T code data (standby) in tool magazine 1	D1371	Records the latest T code data read in the tool magazine 1.	R
T code data (incremental station number) in tool magazine 1	D1372	The incremental station number (the position difference of forward rotation and reverse rotation) of the tool magazine 1 is displayed with this special D register. When the tool magazine forward or reverse rotation special M (M1168 / M1169) is triggered, the remaining tool position difference of tool magazine 1 corresponds to D1372 register immediately.	R
Tool set (standby) in tool magazine 1	D1373	The standby tool set number in tool magazine 1. This tool set number corresponds to D1373.	R



Function name	Special D	Description	Device type
Spindle tool number (in use) in tool magazine 1	D1374	Current spindle tool number in the tool magazine 1.	R
T code data (standby) in tool magazine 2	D1375	Records the latest T code value read in the tool magazine 2.	R
T code data (incremental station number) in tool magazine 2	D1376	The incremental station number (the position difference of forward rotation and reverse rotation) of the tool magazine 2 is displayed with this special D register. When the tool magazine forward or reverse rotation special M (M1172 / M1173) is triggered, the remaining tool position difference of tool magazine 2 corresponds to D1376 register immediately.	R
Tool set (standby) in tool magazine 2	D1377	The standby tool set number in tool magazine 2. This tool set number corresponds to D1377.	R
Spindle tool number (in use) in tool magazine 2	D1378	Current spindle tool number in the tool magazine 2.	R
Feed rate	D1379	Reads the cutting feed rate.	R
Spindle actual speed (32-bit)	D1380	Read spindle speed. This is a 32-bit special D. You can use Pr399 [spindle speed D1380 display mode] to change the source of the display value. Pr399 [Spindle speed D1380 display mode] = 0: source is the program S code command. Pr399 [Spindle speed D1380 display mode] = 1: source is the spindle's real-time command speed.	R
Current G code in use (G01, G02, G03)	D1383	Displays the current G code in use when G01, G02, or G03 is used. (G01 = 1, G02 = 2, G03 = 3)	R
X axis machine coordinate	D1384	X axis machine coordinate. This is a 32-bit special D.	R
Y axis machine coordinate	D1386	Y axis machine coordinate. This is a 32-bit special D.	R
Z axis machine coordinate	D1388	Z axis machine coordinate. This is a 32-bit special D.	R
A axis machine coordinate	D1390	A axis machine coordinate. This is a 32-bit special D.	R
B axis machine coordinate	D1392	B axis machine coordinate. This is a 32-bit special D.	R
C axis machine coordinate	D1394	C axis machine coordinate. This is a 32-bit special D.	R
U axis machine coordinate	D1396	U axis machine coordinate. This is a 32-bit special D.	R
V axis machine coordinate	D1398	V axis machine coordinate. This is a 32-bit special D.	R
W axis machine coordinate	D1400	W axis machine coordinate. This is a 32-bit special D.	R
X axis absolute coordinate	D1402	X axis absolute coordinate. This is a 32-bit special D.	R
Y axis absolute coordinate	D1404	Y axis absolute coordinate. This is a 32-bit special D.	R
Z axis absolute coordinate	D1406	Z axis absolute coordinate. This is a 32-bit special D.	R
A axis absolute coordinate	D1408	A axis absolute coordinate. This is a 32-bit special D.	R
B axis absolute coordinate	D1410	B axis absolute coordinate. This is a 32-bit special D.	R
C axis absolute coordinate	D1012	C axis absolute coordinate. This is a 32-bit special D.	R

Function name	Special D	Description	Device type
U axis absolute coordinate	D1414	U axis absolute coordinate. This is a 32-bit special D.	R
V axis absolute coordinate	D1416	V axis absolute coordinate. This is a 32-bit special D.	R
W axis absolute coordinate	D1418	W axis absolute coordinate. This is a 32-bit special D.	R
X axis DMCNET current monitoring	D1420	X axis DMCNET current monitoring; the data is displayed with one Word (integer). (Current value not updated under HOME mode.)	R
Y axis DMCNET current monitoring	D1421	Y axis DMCNET current monitoring; the data is displayed with one Word (integer). (Current value not updated under HOME mode.)	R
Z axis DMCNET current monitoring	D1422	Z axis DMCNET current monitoring; the data is displayed with one Word (integer). (Current value not updated under HOME mode.)	R
A axis DMCNET current monitoring	D1423	A axis DMCNET current monitoring; the data is displayed with one Word (integer). (Current value not updated under HOME mode.)	R
B axis DMCNET current monitoring	D1424	B axis DMCNET current monitoring; the data is displayed with one Word (integer). (Current value not updated under HOME mode.)	R
C axis DMCNET current monitoring	D1425	C axis DMCNET current monitoring; the data is displayed with one Word (integer). (Current value not updated under HOME mode.)	R
U axis DMCNET current monitoring	D1426	U axis DMCNET current monitoring; the data is displayed with one Word (integer). (Current value not updated under HOME mode.)	R
V axis DMCNET current monitoring	D1427	V axis DMCNET current monitoring; the data is displayed with one Word (integer). (Current value not updated under HOME mode.)	R
W axis DMCNET current monitoring	D1428	W axis DMCNET current monitoring; the data is displayed with one Word (integer). (Current value not updated under HOME mode.)	R
S1 axis DMCNET current monitoring	D1429	S1 axis DMCNET current monitoring; the data is displayed with one Word (integer). (Current value not updated under spindle positioning.)	R
S2 axis DMCNET current monitoring	D1430	S2 axis DMCNET current monitoring; the data is displayed with one Word (integer). (The data is not updated in spindle positioning mode)	R
Workpiece coordinates	D1450	Displays the current workpiece coordinates. Format: GXXPXX. For example, G55 = 5500 and G54P01 = 5401.	R
ADC, TAD, DAC usage	D1464 - D1495	The function of these special D registers (D1464 - D1495) differ based on the system RIO settings. When you set ADC for the system RIO, the four IN ports (ADC Station 4 - 7) correspond to D1464 - D1467, D1472 - D1475, D1480 - D1483 and D1488 - D1491. When you set TAD for the system RIO, the four IN ports (TAD Station 4 - 7) correspond to D1464 - D1471, D1472 - D1479, D1480 - D1487 and D1488 - 1491. When you set DAC for the system RIO, the four IN ports (DAC Station 4 - 7) correspond to D1464 - D1467, D1472 - D1475, D1480 - D1483 and D1488 - D1491.	R/W
User-defined hardware signals	D1500	Customize the positive and negative limit and home signals of the system through the Bit method.	W

Function name	Special D	Description	Device type
User-defined hardware signals	D1501	Customize the positive and negative limit and home signals of the system through the Bit method.	W
User-defined hardware signals	D1502	Customize the positive and negative limit and home signals of the system through the Bit method.	W
User-defined hardware signals	D1503	Customize the positive and negative limit and home signals of the system through the Bit method.	W
X axis residual coordinates	D1506	X axis residual coordinate. This is a 32-bit special D.	R
Y axis residual coordinates	D1508	Y axis residual coordinate. This is a 32-bit special D.	R
Z axis residual coordinates	D1510	Z axis residual coordinate. This is a 32-bit special D.	R
A axis residual coordinates	D1512	A axis residual coordinate. This is a 32-bit special D.	R
B axis residual coordinates	D1514	B axis residual coordinate. This is a 32-bit special D.	R
C axis residual coordinates	D1516	C axis residual coordinate. This is a 32-bit special D.	R
U axis residual coordinates	D1518	U axis residual coordinate. This is a 32-bit special D.	R
V axis residual coordinates	D1520	V axis residual coordinate. This is a 32-bit special D.	R
W axis residual coordinates	D1522	W axis residual coordinate. This is a 32-bit special D.	R
Servo tool magazine 1 command tool number	D1524	The command tool number of the first set of servo tool magazine.	R/W
Servo tool magazine 1 command character	D1525	The command character of the first set of servo tool magazine.	R/W
Servo tool magazine 1 feedback tool number	D1526	The tool number of the first set of servo tool magazine.	R/W
Servo tool magazine 1 feedback status	D1527	The current status of the first set of servo tool magazine.	R/W
Servo tool magazine 2 command tool number	D1528	The command tool number of the second set of servo tool magazine.	R/W
Servo tool magazine 2 command character	D1529	The command character of the second set of servo tool magazine.	R/W
Servo tool magazine 2 feedback tool number	D1530	The tool number of the second set of servo tool magazine.	R/W
Servo tool magazine 2 feedback status	D1531	The current status of the second set of servo tool magazine.	R/W
Servo tool magazine 3 command tool number	D1532	The command tool number of the third set of servo tool magazine.	R/W
Servo tool magazine 3 command character	D1533	The command character of the third set of servo tool magazine.	R/W
Servo tool magazine 3 feedback tool number	D1534	The tool number of the third set of servo tool magazine.	R/W
Servo tool magazine 3 feedback status	D1535	The current status of the third set of servo tool magazine.	R/W

# Troubleshooting

# 15

This chapter provides the information about the alarms and troubleshooting methods for the NC system. Search this chapter for the methods of handling the NC system related malfunctions.

15.1	Alarm Description .....	15-2
15.2	MLC errors (1200 - 13FF).....	15-3
15.3	Servo errors (1E00) .....	15-5
15.4	Remote I/O error (1F00).....	15-5
15.5	HMI related alarms (3010 - 3FFF) .....	15-6
15.6	NC system errors (4200 - 4FFF) .....	15-8
15.7	NC channel errors (B000 - EFFF).....	15-10
15.7.1	Machining related alarms (B000 - B0FF).....	15-10
15.7.2	Tool compensation related alarms (B100 - B1FF) .....	15-12
15.7.3	Milling machine related alarms (B300 - B3FF).....	15-13
15.7.4	Command related alarms (B600 - B6FF; B64x not included) .....	15-14
15.7.5	Temperature compensation related alarms (B640 - B64F) .....	15-16
15.7.6	Lathe cycle command alarms (B6A1 - B6A5).....	15-16

## 15.1 Alarm Description

The CNC alarms can be divided into three categories, which are system alarms, user-defined alarms, and user-defined macro alarms. This chapter mainly explains the system related alarms while the rest are user-defined.

Alarm category	Alarm code	Alarm Description
System alarms	-----	The system alarms caused by system error or operation error. Some system alarms include information (such as servo alarm or PPI alarm); the information included has different meanings according to the different alarms.
User-defined alarms	A_	The user-defined alarms which you use with the MLC program. When the A_ device is triggered, the alarm corresponding to the A_ device also occurs.
User-defined macro alarms	M_	The user-defined macro alarm works with variable #6000. You can have the alarm triggered and have the corresponding macro alarm displayed on the controller.

The system alarms are divided into MLC related alarms and NC related alarms by function.

System alarm category	Alarm code range	Abnormal action	Description
MLC related alarms	1200 - 12FF	MLC system error	-
	1300 - 13FF	Ethernet errors	-
	1E00	Servo error	This alarm displays the information about the servo station number in error and error code.
	1F00	Remote I/O error	This alarm displays the information about the remote I/O station number in error.
HMI related alarms	3010 - 3FFF	HMI error	-
NC related alarms	4200 - 42FF	NC system error	This type of alarm is displayed with the pop-up message, which is not included in the Alarm window and alarm history (History).
	4300 - 43FF	NC system error	-
	B000 - EFFF	NC channel errors	According to the high-byte of the alarm code, you can identify which channel is in error: BXXX: CH0 CXXX: CH1 (reserved) DXXX: CH2 (reserved) EXXX: CH3 (reserved) These types of errors are also displayed differently according to functions. Some alarms carry data and others don't. Thus, you can use the alarm code to check whether the alarm carries data or not.

## 15.2 MLC errors (1200 - 13FF)

Alarm code	Name	Cause and corrective action
1200	NC memory access error	<ol style="list-style-type: none"> <li>1. An error occurs when the MLC accesses the NC memory.</li> <li>2. Restart the CNC controller or send it back for servicing.</li> </ol>
1201	NC not ready	<ol style="list-style-type: none"> <li>1. The startup of the NC system is not complete.</li> <li>2. Restart the CNC controller or send it back for servicing.</li> </ol>
1202	Buffer memory error	<ol style="list-style-type: none"> <li>1. NC memory buffer error or not ready.</li> <li>2. Restart the CNC controller or send it back for servicing.</li> </ol>
1203	Output port does not exist	<ol style="list-style-type: none"> <li>1. NC output port does not exist.</li> <li>2. Check the axis parameter setting.</li> </ol>
1204	MLC code clear error	<ol style="list-style-type: none"> <li>1. Failed to clear the MLC codes.</li> <li>2. Send the CNC controller back for servicing.</li> </ol>
1205	MLC flash memory error	<ol style="list-style-type: none"> <li>1. Failed to write the MLC codes to the flash memory.</li> <li>2. Restart the CNC controller or send it back for servicing.</li> </ol>
1206	SRAM error	<ol style="list-style-type: none"> <li>1. SRAM write-in error.</li> <li>2. Send the CNC controller back for servicing.</li> </ol>
1207	Host I/O channel error	<ol style="list-style-type: none"> <li>1. An error occurs when the system accesses the host I/O.</li> <li>2. Restart the CNC controller or send it back for servicing.</li> </ol>
1208	Remote I/O channel error	<ol style="list-style-type: none"> <li>1. An error occurs when the system accesses the remote I/O.</li> <li>2. Restart the CNC controller or send it back for servicing.</li> </ol>
120A	NC parameter error	<ol style="list-style-type: none"> <li>1. NC parameters are not set or initialized.</li> <li>2. Re-initialize the parameters.</li> </ol>
120B	Compensation PAR error	<ol style="list-style-type: none"> <li>1. Compensation parameter write-in error</li> <li>2. Reload the compensation parameters.</li> </ol>
120C	Compen. PAR clear error	<ol style="list-style-type: none"> <li>1. An error occurs when the system clears the compensation parameter in memory.</li> <li>2. Reload the compensation parameters.</li> </ol>
120D	Compen. PAR write-in error	<ol style="list-style-type: none"> <li>1. An error occurs when the system writes the compensation parameters to memory.</li> <li>2. Reload the compensation parameters.</li> </ol>
120E	PAR initialization error	<ol style="list-style-type: none"> <li>1. Parameter initialization error.</li> <li>2. Re-initialize the parameters.</li> </ol>
120F	Memory clear error	<ol style="list-style-type: none"> <li>1. Memory clear error.</li> <li>2. Restart the CNC controller or send it back for servicing.</li> </ol>
1210	Memory write-in error	<ol style="list-style-type: none"> <li>1. Memory write-in error or memory initialization error.</li> <li>2. Restart the CNC controller or send it back for servicing.</li> </ol>
1211	Servo axis does not exist	<ol style="list-style-type: none"> <li>1. Parameter setting error.</li> <li>2. Check the parameter settings.</li> </ol>
1212	Servo axis PAR type error	<ol style="list-style-type: none"> <li>1. Parameter setting error.</li> <li>2. Check the parameter settings.</li> </ol>
1213	DMCNET initialization error	<ol style="list-style-type: none"> <li>1. DMCNET initialization error.</li> <li>2. Make sure the DMCNET cable is securely connected.</li> </ol>
1214	Non-volatile memory error	<ol style="list-style-type: none"> <li>1. Non-volatile memory error.</li> <li>2. Restart the CNC controller or send it back for servicing.</li> </ol>
1215	Internal comm. error	<ol style="list-style-type: none"> <li>1. MLC and NC bottom layer communication error.</li> <li>2. Use the correct firmware version.</li> <li>3. Set the correct channel parameters.</li> </ol>

15

Alarm code	Name	Cause and corrective action
1216	MLC PRG error	<ol style="list-style-type: none"> <li>1. The following conditions occur when the MLC is in execution:                             <ul style="list-style-type: none"> <li>■ The divisor of the division command is 0.</li> <li>■ The jump target position of the CJ/CALL command is invalid.</li> <li>■ The number of digits displayed in the BCD command is invalid.</li> <li>■ The table number of the VRT command is invalid.</li> <li>■ MLC code error.</li> </ul> </li> <li>2. Check and correct the MLC program.</li> <li>3. Reload the MLC program.</li> </ol>
1217	MLC PAR does not match	<ol style="list-style-type: none"> <li>1. Current number of MLC parameters in the internal memory do not match the number of parameters planned in the firmware.</li> <li>2. Update the firmware.</li> </ol>

### 15.3 Servo errors (1E00)

Alarm code	Name	Cause and corrective action
1E00	Servo error	<p>[1530]: alarm signal (DI) on the pulse card is triggered. Check the error cause of the connected drive.</p> <p>[1531]: this alarm occurs when the pulse card generates more than 24,000 pulses within 1 ms. Check the controller's encoder resolution setting and make sure the motor speed is within the range.</p> <p>[1532]: pulse leakage. When the motor is stopped, the pulse card compares the command pulse number with the feedback pulse number. If the pulse number difference is greater than 1% of the encoder resolution, this alarm occurs.</p> <ol style="list-style-type: none"> <li>1. Check if the signal traces are shielded.</li> <li>2. Check if the equipment is properly grounded.</li> </ol> <p>[1560]: station number repetition error.</p> <ol style="list-style-type: none"> <li>1. Check the channel parameter station number setting.</li> <li>2. Check the pulse card station number switch knob setting.</li> <li>3. Check the drive station number P3-00 setting.</li> </ol> <p>Refer to the relevant servo drive user manuals for the definition and troubleshooting of other related errors.</p>

15

### 15.4 Remote I/O error (1F00)

Alarm code	Name	Cause and corrective action
1F00	Remote I/O error	<ol style="list-style-type: none"> <li>1. Remote I/O error.</li> <li>2. Check the remote I/O connection or replace the remote I/O board.</li> </ol>



## 15.5 HMI related alarms (3010 - 3FFF)

Alarm code	Name	Cause and corrective action
3010	HMI communication interface establishing error	<ol style="list-style-type: none"> <li>1. An error occurs when the system establishes the HMI communication interface.</li> <li>2. Restart the CNC controller or send it back for servicing.</li> </ol>
3011	HMI communication memory area creating error	<ol style="list-style-type: none"> <li>1. An error occurs when the system creates the HMI communication memory area.</li> <li>2. Restart the CNC controller or send it back for servicing.</li> </ol>
3012	HMI interface command area error	<ol style="list-style-type: none"> <li>1. An error occurs when the system creates the HMI interface command area.</li> <li>2. Restart the CNC controller or send it back for servicing.</li> </ol>
3013	HMI interface memory area error	<ol style="list-style-type: none"> <li>1. HMI interface memory area error.</li> <li>2. Restart the CNC controller or send it back for servicing.</li> </ol>
3014	HMI interface communication port error	<ol style="list-style-type: none"> <li>1. HMI interface communication port error.</li> <li>2. Restart the CNC controller or send it back for servicing.</li> </ol>
3015	MLC interface memory area error	<ol style="list-style-type: none"> <li>1. MLC interface memory area error.</li> <li>2. Restart the CNC controller or send it back for servicing.</li> </ol>
3016	HMI file transmission error	<ol style="list-style-type: none"> <li>1. HMI file transmission error.</li> <li>2. Restart the CNC controller or send it back for servicing.</li> </ol>
3017	HMI data transmission error	<ol style="list-style-type: none"> <li>1. HMI data transmission error.</li> <li>2. Restart the CNC controller or send it back for servicing.</li> </ol>
3018	FTP PAR setting error	<ol style="list-style-type: none"> <li>1. Incorrect FTP setting.</li> <li>2. Reconfirm FTP related settings.</li> </ol>
3100	Invalid file name	<ol style="list-style-type: none"> <li>1. Invalid file name.</li> <li>2. Modify the file name.</li> </ol>
3101	Exceeded subroutine call LVL	<ol style="list-style-type: none"> <li>1. The macro call exceeded 8 layers.</li> <li>2. Check the macro program.</li> </ol>
3102	Non-G code character error	<ol style="list-style-type: none"> <li>1. Non-G code character error.</li> <li>2. Check the G code and modify the program.</li> </ol>
3103	Memory error	<ol style="list-style-type: none"> <li>1. System internal memory area is in error.</li> <li>2. Use the recovery function of the CNC controller or send the controller back for servicing.</li> </ol>
3200	Internal PAR CRC error	<ol style="list-style-type: none"> <li>1. System internal parameter memory area is in error.</li> <li>2. Use the recovery function of the CNC controller or send the controller back for servicing.</li> </ol>
3201	MLC PRG error	<ol style="list-style-type: none"> <li>1. System MLC program memory area is in error.</li> <li>2. Reload the MLC program or send the CNC controller back for servicing.</li> </ol>
3202	CF card read failed	<ol style="list-style-type: none"> <li>1. No CF card is inserted or the inserted CF card is invalid.</li> <li>2. Make sure the CF card is correctly installed or replace the CF card.</li> </ol>
3203	PAR backup failed	Confirm that the CF card is inserted correctly and has sufficient space.
3204	MLC backup failed	Confirm that the CF card is inserted correctly and has sufficient space.
3205	Machine is locked	<ol style="list-style-type: none"> <li>1. The usage duration has expired.</li> <li>2. Contact the equipment manufacturer to unlock or extend the machine usage duration.</li> </ol>
3206	PAR value exceeds the range	<ol style="list-style-type: none"> <li>1. There are system parameters with set values exceeding the allowable range.</li> <li>2. Check and modify the parameter values.</li> </ol>
3207	COM port DLL load error	<ol style="list-style-type: none"> <li>1. Failed to load the external device driver with the software panel.</li> <li>2. Update the software panel to reload the external device driver.</li> </ol>

Alarm code	Name	Cause and corrective action
3208	Machine to be locked soon	<ol style="list-style-type: none"> <li>1. System usage duration expiring reminder.</li> <li>2. Contact the equipment manufacturer to unlock or extend the machine usage duration.</li> </ol>
3209	Sys updated, please restart the controller.	<ol style="list-style-type: none"> <li>1. The system update is complete and requires restarting.</li> <li>2. Restart the CNC controller.</li> </ol>
320A	CNC controller has insufficient battery power	<ol style="list-style-type: none"> <li>1. The CNC controller system battery is low.</li> <li>2. Replace the battery of the CNC controller.</li> </ol>
3210	COM port disconnection	<ol style="list-style-type: none"> <li>1. The connection between the software panel and the external device is disconnected.</li> <li>2. Check the connection settings between the controller and the external device.</li> </ol>
3211	COM port DLL open error	<ol style="list-style-type: none"> <li>1. Failed to open the external device driver with the software panel.</li> <li>2. Update the software panel to reload the external device driver.</li> </ol>
3212	Failed to create COM port	<ol style="list-style-type: none"> <li>1. An error occurs when the external device driver is loaded with the software panel.</li> <li>2. Update the software panel and make sure the setting of the external link file is correct.</li> </ol>
3213	Load TCPIP DLL Err	<ol style="list-style-type: none"> <li>1. Failed to load the TCPIP driver with the software panel.</li> <li>2. Update the software panel to reload the external device driver.</li> </ol>
3214	TCPIP comm. disconnection	<ol style="list-style-type: none"> <li>1. Network connection is in error.</li> <li>2. Check the network connection or connection status.</li> </ol>
3215	Network comm. init. failed	<ol style="list-style-type: none"> <li>1. Failed to initialize the network communication.</li> <li>2. Check the network connection or connection status.</li> </ol>
3216	System reset error	<ol style="list-style-type: none"> <li>1. No response from the bottom layer after resetting.</li> <li>2. Update the CNC controller firmware or send the controller back for servicing.</li> </ol>
3217	Failed to import full backup	<ol style="list-style-type: none"> <li>1. Failed to remotely enable the backup import.</li> <li>2. Check the operating mode. Make sure the backup storage device is correctly installed.</li> </ol>
3218	Failed to export full backup	<ol style="list-style-type: none"> <li>1. Failed to remotely enable the backup export.</li> <li>2. Check the operating mode. Make sure the backup storage device is correctly installed.</li> </ol>
3219	Auto update is set, please reboot	<ol style="list-style-type: none"> <li>1. Failed to remotely enable the firmware update function.</li> <li>2. Cycle the power to start the automatic firmware update function. You must put the firmware file in the [pkt] folder in the root directory of the USB disk.</li> </ol>
3220	Sys. update failed, please reboot	<ol style="list-style-type: none"> <li>1. Failed to update the remote system firmware.</li> <li>2. After checking the following conditions, reset the automatic firmware update function: <ul style="list-style-type: none"> <li>■ Firmware update model error.</li> <li>■ File format does not match.</li> <li>■ Firmware update version is not supported.</li> <li>■ Controller emergency stop is not pressed.</li> </ul> </li> </ol>

## 15.6 NC system errors (4200 - 4FFF)

Alarm code	Name	Cause and corrective action
4200	Execute homing	<ol style="list-style-type: none"> <li>Homing has not been executed for each axis before automatic operation.</li> <li>Execute homing for each axis.</li> </ol>
4201	Absolute origin setting	<ol style="list-style-type: none"> <li>The origin coordinates for the absolute type motor are not established.</li> <li>Go to [DGN] to execute ABS RST.</li> </ol>
4300	MLC is not ready	<ol style="list-style-type: none"> <li>An error occurs when the MLC accesses the memory.</li> <li>Restart the CNC controller, update firmware, or send the controller back for servicing.</li> </ol>
4301	MLC is not ready	<ol style="list-style-type: none"> <li>The MLC is not ready.</li> <li>Restart the CNC controller, update firmware, or send the controller back for servicing.</li> </ol>
4302	I/O module program clearing failed	<ol style="list-style-type: none"> <li>Failed to clear the I/O module program.</li> <li>Send the CNC controller back for servicing.</li> </ol>
4303	I/O module program write-in failed	<ol style="list-style-type: none"> <li>Failed to write the I/O module program.</li> <li>Send the CNC controller back for servicing.</li> </ol>
4304	NC system program clearing failed	<ol style="list-style-type: none"> <li>Failed to clear the NC system program.</li> <li>Restart the CNC controller, update firmware, or send the controller back for servicing.</li> </ol>
4305	NC system program installation failed	<ol style="list-style-type: none"> <li>Failed to install the NC system program.</li> <li>Restart the CNC controller, update firmware, or send the controller back for servicing.</li> </ol>
4306	Macro clearing failed	<ol style="list-style-type: none"> <li>Failed to clear the macro program.</li> <li>Restart the CNC controller and execute the macro internal memory function.</li> </ol>
4307	Macro installation failed	<ol style="list-style-type: none"> <li>Failed to install the macro program.</li> <li>Restart the CNC controller and execute the macro internal memory function.</li> </ol>
4308	G code loading error	<ol style="list-style-type: none"> <li>An error occurs when loading the G code.</li> <li>Check the machining program.</li> </ol>
4309	Illegal program location	<ol style="list-style-type: none"> <li>Motion defined but not called.</li> <li>Update the CNC controller firmware and restart the controller.</li> </ol>
430A	Exceeded maximum read memory area	<ol style="list-style-type: none"> <li>Motion defined but not called.</li> <li>Update the CNC controller firmware and restart the controller.</li> </ol>
430B	Exceeded maximum write memory area	<ol style="list-style-type: none"> <li>Motion defined but not called.</li> <li>Update the CNC controller firmware and restart the controller.</li> </ol>
4310	I/O module PRG not initialized	<ol style="list-style-type: none"> <li>The I/O module program is not initialized.</li> <li>Send the CNC controller back for servicing.</li> </ol>
4311	I/O module memory corrupted	<ol style="list-style-type: none"> <li>The I/O module memory is corrupted.</li> <li>Send the CNC controller back for servicing.</li> </ol>
4312	I/O module memory corrupted	<ol style="list-style-type: none"> <li>The I/O module memory is corrupted.</li> <li>Send the CNC controller back for servicing.</li> </ol>
4313	I/O module status error	<ol style="list-style-type: none"> <li>The I/O module status is in error.</li> <li>Check if the I/O board is firmly installed and the wiring is securely connected.</li> </ol>
4314	I/O module PRG configuration error	<ol style="list-style-type: none"> <li>Program configuration of the I/O module is in error.</li> <li>Check if the I/O board is firmly installed and the wiring is securely connected.</li> </ol>

15

Alarm code	Name	Cause and corrective action
4315	I/O board hardware interface error	<ol style="list-style-type: none"> <li>1. The I/O board hardware interface is in error.</li> <li>2. Send the CNC controller back for servicing.</li> </ol>
4316	I/O board hardware interface error	<ol style="list-style-type: none"> <li>1. An error occurs when the system reads the I/O board hardware interface.</li> <li>2. Send the CNC controller back for servicing.</li> </ol>
4317	NC system command error	<ol style="list-style-type: none"> <li>1. The NC system command is in error.</li> <li>2. Check the machining program or the macro content.</li> </ol>
4318	NC parameter error	<ol style="list-style-type: none"> <li>1. The NC parameter does not exist or the MLC is not ready.</li> <li>2. Restart the CNC controller, update firmware, or send the controller back for servicing.</li> </ol>
4319	NC parameter error	<ol style="list-style-type: none"> <li>1. The NC parameter does not exist or the MLC is not ready.</li> <li>2. Restart the CNC controller, update firmware, or send the controller back for servicing.</li> </ol>
431A	Tool magazine axis error	<ol style="list-style-type: none"> <li>1. The tool magazine axis number is not defined or defined repeatedly.</li> <li>2. Check the parameter settings.</li> </ol>
431B	NC parameter error	<ol style="list-style-type: none"> <li>1. The NC parameter is in error.</li> <li>2. Make sure no parameter values are set to 0, such as the encoder pulse number, the gear numbers of the output shaft and motor.</li> </ol>
431C	Spindle polarity error	<ol style="list-style-type: none"> <li>1. Spindle voltage output does not match the motor rotation direction.</li> <li>2. Check whether the spindle encoder OA/OB wiring is correct.</li> <li>3. By setting Pr51 [1<sup>st</sup> Spindle OA/OB signal order], you can adjust the OA/OB phase sequence of the spindle encoder feedback.</li> </ol>
4FFC	Servo overflow protection	<ol style="list-style-type: none"> <li>1. This alarm occurs when the Servo On / Off action is executed in AUTO mode and the position overflow occurs on the specified axis, so the system does not execute this Servo On / Off action.</li> <li>2. Check the servo parameters for preventing position overflow.</li> </ol>
4FFD	Position feedback protection	<ol style="list-style-type: none"> <li>1. When the motion command is issued, the position feedback did not change.</li> <li>2. Confirm servo settings; for example, the torque limit value is too small.</li> <li>3. Check if the servo feedback signal wiring functions normally.</li> <li>4. Check if the motor rotates normally.</li> </ol>
4FFE	Overspeed protection	<ol style="list-style-type: none"> <li>1. There is an overspeed motion command.</li> <li>2. Make sure the parameter settings are not set too high, such as the output gear ratio and cutting speed setting.</li> </ol>

## 15.7 NC channel errors (B000 - EFFF)

### 15.7.1 Machining related alarms (B000 - B0FF)

Alarm code	Name	Cause and corrective action
B000	Illegal G code line number	<ol style="list-style-type: none"> <li>The G code line number is illegal.</li> <li>Check the machining program.</li> </ol>
B001	Illegal G code length	<ol style="list-style-type: none"> <li>The G code length is illegal.</li> <li>Check the machining program.</li> </ol>
B002	G code file not found	<ol style="list-style-type: none"> <li>The G code file is not found.</li> <li>Check the file contents.</li> </ol>
B003	Invalid file name loaded	<ol style="list-style-type: none"> <li>The name of the loaded file is invalid.</li> <li>Reload the program file.</li> </ol>
B004	Workpiece coordinates computing error	<ol style="list-style-type: none"> <li>An error occurs when the system computes the workpiece coordinates.</li> <li>Reset the workpiece coordinates.</li> </ol>
B005	Workpiece coordinates computing error	<ol style="list-style-type: none"> <li>An error occurs when the system computes the workpiece coordinates.</li> <li>Reset the workpiece coordinates.</li> </ol>
B006	Workpiece coordinates computing error	<ol style="list-style-type: none"> <li>An error occurs when the system computes the workpiece coordinates.</li> <li>Reset the workpiece coordinates.</li> </ol>
B007	Servo port setting conflict	<ol style="list-style-type: none"> <li>There is a conflict in the servo port settings.</li> <li>Check the parameter settings.</li> </ol>
B008	Memory overlap	<ol style="list-style-type: none"> <li>An error occurs when the system internal program is operating.</li> <li>Reload the machining program or update the firmware.</li> </ol>
B009	G code buffer error	<ol style="list-style-type: none"> <li>The G code buffer is in error.</li> <li>Reload the machining program or update the firmware.</li> </ol>
B025	G code format error	Check the N label of the machining program again.
B00A	Interpolator cmd index Err	<ol style="list-style-type: none"> <li>An error occurs to the computing interpolator command index in the system.</li> <li>Reload the machining program or update the firmware.</li> </ol>
B00B	INTRPL cmd BUF access Err	<ol style="list-style-type: none"> <li>An error occurs when the system accesses the buffer of the computing interpolator command.</li> <li>Reload the machining program or update the firmware.</li> </ol>
B00C	Undefined feed rate	<ol style="list-style-type: none"> <li>The feed rate is undefined.</li> <li>Check the machining program and define the feed rate.</li> </ol>
B00D	Arc radius error	<ol style="list-style-type: none"> <li>Arc radius calculation is in error.</li> <li>Check the arc machining program or increase the tolerance for arc radius error.</li> </ol>
B00E	Tool No. selection Err	<ol style="list-style-type: none"> <li>The specified tool number is in error during tool change or T code execution.</li> <li>Check the changed tool number and if the T code setting is within the tool setting range.</li> </ol>
B00F	Servo connection axes and parameter setting mismatch	<ol style="list-style-type: none"> <li>The number of the connection axes does not match the parameter setting.</li> <li>Check the set channel port number and the connecting servo station number setting.</li> </ol>
B010	Breakpoint No. not found	<ol style="list-style-type: none"> <li>Breakpoint search is assigned to M99.</li> <li>Reset the breakpoint search line number.</li> </ol>

Alarm code	Name	Cause and corrective action
B015	Sync cmd error	<ol style="list-style-type: none"> <li>1. This alarm occurs when the synchronous function is enabled and you use the G code to specify the slave axis moving amount.</li> <li>2. Check the machining program. After the synchronous function is enabled, do not specify the slave axis moving amount in the G code.</li> </ol>
B017	Tool assignment error	<ol style="list-style-type: none"> <li>1. The tool compensation number in the G code exceeds the number range.</li> <li>2. Adjust the tool compensation number setting in the G code.</li> </ol>
B018	Cmd transfer not allowed	<ol style="list-style-type: none"> <li>1. An error occurs when the system checks for the command transfer in MDI mode.</li> <li>2. Command transfer can only be done before the machining program is executed.</li> </ol>
B019	Servo command error	<ol style="list-style-type: none"> <li>1. The axis does not receive G code motion commands when the servo is off.</li> <li>2. Check if the command axis is in the Servo Off state.</li> </ol>
B01A	Data amount error	<ol style="list-style-type: none"> <li>1. The processing amount of the interface data exceeds the preset value, such as tool changing, magazine setting, variable writing (#), and G10 data setting.</li> <li>2. Check if the G codes and MLC processing actions are operating normally.</li> </ol>
B01B	Spindle not running	<ol style="list-style-type: none"> <li>1. The spindle is not rotating during machining.</li> <li>2. Make sure the spindle rotation command is issued.</li> </ol>
B01C	Spindle cmd speed error	<ol style="list-style-type: none"> <li>1. The spindle command exceeds the spindle maximum speed.</li> <li>2. Redefine the spindle speed.</li> <li>3. Adjust Pr409 for the spindle maximum speed setting.</li> </ol>
B01D	Stroke limit error	<ol style="list-style-type: none"> <li>1. The stop function is triggered when the path enters the restricted area.</li> <li>2. AUTO mode: correct the G code execution path.</li> <li>3. MDI mode: move to the opposite direction of the restricted area to clear the error.</li> </ol>
B020	Emergency stop	<ol style="list-style-type: none"> <li>1. An emergency stop occurs.</li> <li>2. Check if the EMG button is pressed.</li> <li>3. Check the emergency stop status.</li> </ol>
B021	Chamfer / rounding Err	<ol style="list-style-type: none"> <li>1. The chamfer / rounding command cannot be calculated.</li> <li>2. Check and adjust the chamfer / rounding command in the G code.</li> </ol>
B023	Illegal G code in command transferring	Use of the G28 command is not permitted in the transfer function.

**15.7.2 Tool compensation related alarms (B100 - B1FF)**

Alarm code	Name	Cause and corrective action
B100	Tool compen. interference	<ol style="list-style-type: none"> <li>1. Tool compensation is interfered or the calculation for the tool compensation coordinates is in error.</li> <li>2. Check and modify the programmed machining path or the tool radius for compensation.</li> </ol>
B101	Cancel radius compen. in arc	<ol style="list-style-type: none"> <li>1. This alarm occurs when you cancel the tool radius compensation when the block containing arc interpolation is executed.</li> <li>2. Modify the machining program to disable the tool radius compensation during linear interpolation.</li> </ol>
B102	Enable radius compen. in arc	<ol style="list-style-type: none"> <li>1. This alarm occurs when you enable tool radius compensation when the block containing arc interpolation is executed.</li> <li>2. Modify the machining program to disable the tool radius compensation during linear interpolation.</li> </ol>
B103	Radius interference	<ol style="list-style-type: none"> <li>1. The tool path is interfered after tool radius compensation.</li> <li>2. Check and modify the machining program or the tool radius for compensation.</li> </ol>
B104	Tool compen. amount too small	<ol style="list-style-type: none"> <li>1. The tool compensation path is too short.</li> <li>2. Check and modify the machining program or the tool radius for compensation.</li> </ol>
B105	Left and right tool radius compensation (G41/G42) switch error	<ol style="list-style-type: none"> <li>1. An error occurs when the system switches the tool radius compensation to the right or left direction.</li> <li>2. Check and modify the machining program path.</li> </ol>
B106	Use G31 in tool compen.	<ol style="list-style-type: none"> <li>1. This alarm occurs when the system executes G31 during tool radius compensation.</li> <li>2. Check and modify the machining program.</li> </ol>
B108	NURBS interpolation error	<ol style="list-style-type: none"> <li>1. NURBS interpolation is in error.</li> <li>2. Check if the G code in the NURBS function complies with the command format.</li> <li>3. Check if the NURBS first control point is the same as the coordinate in the previous block.</li> </ol>
B109	Insufficient space arc block	<ol style="list-style-type: none"> <li>1. There is insufficient arc interpolation points.</li> <li>2. Check and modify the machining program.</li> </ol>
B10D	Illegal polygon interpolation G code	An error occurs when you repeatedly assign the G51.2 polygon cutting command.

15

### 15.7.3 Milling machine related alarms (B300 - B3FF)

Alarm code	Name	Cause and corrective action
B301	Threading pitch error	<ol style="list-style-type: none"> <li>The calculation result of the variable lead thread is less than 0.</li> <li>Check the G code command and modify the program.</li> </ol>
B302	Spindle speed too fast	<ol style="list-style-type: none"> <li>The turning feed rate for thread cutting is too fast.</li> <li>Reduce the spindle speed.</li> </ol>
B303	Spindle/C axis switching Err	<ol style="list-style-type: none"> <li>You switch the system from Spindle mode to C axis mode while the C axis mode is disabled.</li> <li>Set Pr308 to 0 for the C axis mode.</li> </ol>
B304	Thread cutting prohibited in C axis mode	<ol style="list-style-type: none"> <li>Thread cutting operation is prohibited in C axis mode.</li> <li>Switch the system from C axis mode to spindle mode to execute the thread cutting operation.</li> </ol>
B305	C axis/spindle mode error	<ol style="list-style-type: none"> <li>In C axis mode, both SP1 and SP2 are set to voltage mode.</li> <li>Adjust the spindle control mode settings of SP1 and SP2.</li> </ol>
B306	Spindle mode breakpoint search error	<ol style="list-style-type: none"> <li>In Spindle mode, the breakpoint search is in progress, but there is an M code for switching the system from Spindle mode to C axis mode.</li> <li>Reset the breakpoint search line number.</li> </ol>
B307	C axis mode breakpoint search error	<ol style="list-style-type: none"> <li>In C axis mode, the breakpoint search is in progress, but there is an M code for switching the system from C axis mode to Spindle mode.</li> <li>Reset the breakpoint search line number.</li> </ol>
B308	Polar coordinate interpolation error	<ol style="list-style-type: none"> <li>An error occurs when the system executes the polar coordinate interpolation command.</li> <li>Check if the polar coordinate interpolation G code complies with the command format.</li> <li>Check if the polar coordinate interpolation includes unsupported G code commands.</li> <li>Check if the plane selection is switched when the system is executing the polar coordinate command.</li> <li>Check if there is a specified tool number in the polar coordinate interpolation.</li> <li>Check whether the polar coordinate interpolation is in the following conditions: <ol style="list-style-type: none"> <li>The system is in fixed spindle speed mode.</li> <li>The tool nose compensation is canceled.</li> <li>The system is in C axis mode.</li> </ol> </li> </ol>



**15.7.4 Command related alarms (B600 - B6FF; B64x not included)**

Alarm code	Name	Cause and corrective action
B600	G code error	<ol style="list-style-type: none"> <li>G code error.</li> <li>Check the G code and modify the program.</li> </ol>
B601	Excessive layers in subroutine call	<ol style="list-style-type: none"> <li>The subroutine called excessive program layers.</li> <li>The subroutine cannot call program layers exceeding 8 levels.</li> </ol>
B602	No G code symbol	<ol style="list-style-type: none"> <li>No correct G code symbol.</li> <li>Check the G code and modify the program.</li> </ol>
B603	Variable symbol error	<ol style="list-style-type: none"> <li>The variable symbol is in error.</li> <li>Check the G code and modify the program.</li> </ol>
B604	Illegal G code symbol	<ol style="list-style-type: none"> <li>The G code symbol is illegal.</li> <li>Check the G code and modify the program.</li> </ol>
B605	No G code symbol	<ol style="list-style-type: none"> <li>There is no G code symbol.</li> <li>Check the G code and modify the program.</li> </ol>
B606	Subroutine call error	<ol style="list-style-type: none"> <li>The subroutine call is in error.</li> <li>Modify the program.</li> </ol>
B607	Subroutine file name error	<ol style="list-style-type: none"> <li>The subroutine file name is in error.</li> <li>Modify the program.</li> </ol>
B608	Subroutine layer No. error	<ol style="list-style-type: none"> <li>The subroutine layer number is in error.</li> <li>Modify the program.</li> </ol>
B609	Cycle EXEC, no homing	<ol style="list-style-type: none"> <li>G code is executed without homing.</li> <li>Execute homing for each axis first.</li> </ol>
B60A	Dwell time cmd syntax error	<ol style="list-style-type: none"> <li>The syntax for the dwell time command is in error.</li> <li>Check the G code and modify the program.</li> </ol>
B60B	WP coord offset error	<ol style="list-style-type: none"> <li>An error occurs when the system computes the workpiece coordinate offset.</li> <li>Restart the CNC controller or send it back for servicing.</li> </ol>
B60C	Arc magnification ratio error	<ol style="list-style-type: none"> <li>The arc magnification ratio is in error.</li> <li>Check the G code and modify the program.</li> </ol>
B60D	Homing midpoint Err	<ol style="list-style-type: none"> <li>An error occurs when the system performs homing through the intermediate point.</li> <li>Check the G code and modify the program.</li> </ol>
B60E	Homing Err in Cyc machining	<ol style="list-style-type: none"> <li>Do not execute G28 / G29 / G30 during cyclic machining.</li> <li>Check the G code and modify the program.</li> </ol>
B60F	G54 extension code err	<ol style="list-style-type: none"> <li>The specified range for the extended workpiece coordinates is in error.</li> <li>Check the G code specified range.</li> </ol>
B610	Macro variable type error	<ol style="list-style-type: none"> <li>The macro variable type is in error.</li> <li>Check the macro and modify the program.</li> </ol>
B611	Macro not found	<ol style="list-style-type: none"> <li>The macro command is not found.</li> <li>Check the macro and modify the program.</li> </ol>
B612	Macro line No. error	<ol style="list-style-type: none"> <li>The specified N is not found when the system executes the GO TO command.</li> <li>Modify the program.</li> </ol>
B613	Macro bit setting error	<ol style="list-style-type: none"> <li>The setting for the macro bit is in error.</li> <li>Check the macro and modify the program.</li> </ol>
B614	Macro divide by zero error	<ol style="list-style-type: none"> <li>This error occurs when the macro performs division operation and the divisor is zero.</li> <li>Check the macro and modify the program.</li> </ol>
B615	Macro command too long	<ol style="list-style-type: none"> <li>The macro command is too long.</li> <li>Check the macro and modify the program.</li> </ol>

15

Alarm code	Name	Cause and corrective action
B616	Macro Cmd operand not exist	<ol style="list-style-type: none"> <li>The macro command operand does not exist.</li> <li>Check the macro and modify the program.</li> </ol>
B617	Macro command error	<ol style="list-style-type: none"> <li>The macro command is in error.</li> <li>Check the macro and modify the program.</li> </ol>
B618	Macro Cmd syntax error	<ol style="list-style-type: none"> <li>The macro syntax usage is illegal.</li> <li>Check the macro and modify the program.</li> </ol>
B619	The macro operand syntax is in error	<ol style="list-style-type: none"> <li>The macro operand syntax is in error.</li> <li>Check the macro and modify the program.</li> </ol>
B61A	Illegal macro command	<ol style="list-style-type: none"> <li>The macro command is illegal.</li> <li>Check the macro and modify the program.</li> </ol>
B61B	GOTO tag is not found	<ol style="list-style-type: none"> <li>No corresponding tag is found in the G code.</li> <li>Check the G code and specify the correct tag.</li> </ol>
B61C	No line No. given by GOTO	<ol style="list-style-type: none"> <li>No corresponding line number is found in the G code.</li> <li>Check the G code and specify the correct line number.</li> </ol>
B620	User-defined macro alarm	<ol style="list-style-type: none"> <li>User-defined macro alarm is triggered.</li> <li>#6000 in the G code must not be specified as 0.</li> </ol>
B621	Invalid halt code	<ol style="list-style-type: none"> <li>The halt code is invalid.</li> <li>Check the G code and the halt code (M code) must be used individually.</li> </ol>
B623	feed rate is negative	<ol style="list-style-type: none"> <li>The feed rate is set as a negative value.</li> <li>Check the G code and adjust the feed rate.</li> </ol>
B625	Interpolation axis error	<ul style="list-style-type: none"> <li>■ Milling &amp; Lathe: synchronous interpolation for linear axis and rotary axis is not supported.</li> <li>■ Milling machine: <ol style="list-style-type: none"> <li>NC200 does not support tapping.</li> <li>Use NC300 or above models.</li> </ol> </li> </ul>
B630	Excessive following error	<ol style="list-style-type: none"> <li>The following error is too large.</li> <li>Make sure the servo parameter setting is correct.</li> <li>Check if the system parameter 643 is set too small.</li> </ol>
B631	Hardware limit error	<ol style="list-style-type: none"> <li>The hardware limit is triggered.</li> <li>Move the axis into the legal restricted range.</li> <li>Check the hardware limit wiring and polarity settings.</li> </ol>
B632	1st software limit error	<ol style="list-style-type: none"> <li>The axis position exceeds the first software limit.</li> <li>Move the axis into the legal restricted range.</li> </ol>
B634	2nd software limit error	<ol style="list-style-type: none"> <li>The axis position exceeds the second software limit.</li> <li>Move the axis into the legal restricted range.</li> </ol>
B636	Home sensor error	<ol style="list-style-type: none"> <li>The home sensor is in error.</li> <li>Check if the home sensor is installed correctly.</li> </ol>
B637	MLC axis not stopped	<ol style="list-style-type: none"> <li>When the system switches between the MLC and NC axis modes, the MLC axis is still in motion.</li> <li>Modify the MLC program.</li> </ol>
B645	Excessive synchronous following error	<ol style="list-style-type: none"> <li>The position error between the master axis and synchronous axis is too great.</li> <li>Check whether the following error between the slave axis and master axis exceeded the Pr642 parameter value.</li> </ol>
B650	Illegal G10 PAR definition	<ol style="list-style-type: none"> <li>The G10 parameter definition is illegal.</li> <li>Check if the G code is used correctly.</li> </ol>
B651	G10 PAR range error	<ol style="list-style-type: none"> <li>The G10 parameter range is set incorrectly.</li> <li>Check if the G code parameter range is correct.</li> </ol>
B652	No spindle speed for cycle	<ol style="list-style-type: none"> <li>There is no spindle speed in the cycle command.</li> <li>Check the G code and specify the spindle speed.</li> </ol>
B653	No feed rate for cycle	<ol style="list-style-type: none"> <li>There is no feed rate in the cycle command.</li> <li>Check the G code and specify the feed rate.</li> </ol>

Alarm code	Name	Cause and corrective action
B654	Illegal cycle command	<ol style="list-style-type: none"> <li>The usage of the cycle command is illegal.</li> <li>Check the G code and modify the cycle command.</li> </ol>
B655	Special function when executed to M96 Not off	<ol style="list-style-type: none"> <li>Illegal M code command.</li> <li>Check whether specific G code was enabled before and after executing M96. Note: Including G16, G24, G41, G42 and G51.</li> </ol>
B656	Gave the M96 command under interrupt subroutine Command	<ol style="list-style-type: none"> <li>Call subroutine Special M was triggered while executing G code.</li> <li>Check whether the subroutine includes the M96 command.</li> </ol>

**15.7.5 Temperature compensation related alarms (B640 - B64F)**

Alarm code	Name	Cause and corrective action
B640	Overheat	<ol style="list-style-type: none"> <li>The temperature exceeds the sensing range.</li> <li>Check the sensor's output specification.</li> </ol>
B642	Temperature sensor disconnected	<ol style="list-style-type: none"> <li>The temperature sensor is disconnected.</li> <li>Check if the wiring for the temperature sensor functions normally.</li> </ol>
B643	Temperature detection error	<ol style="list-style-type: none"> <li>The temperature sensor is in error.</li> <li>Check if the temperature sensor is installed correctly.</li> </ol>
B646	Spindle rotation speed error too large	<ol style="list-style-type: none"> <li>The difference between the 1st spindle (2nd spindle) command rotation speed and feedback rotation speed is greater than the parameter Pr406 (Pr446), and continually exceeds the spindle rotation speed error check time set by parameter Pr436 (Pr476).</li> <li>When the parameter (Pr436 and Pr476) is set as 0, the spindle rotation speed reached check will not be performed.</li> </ol>

**15.7.6 Lathe cycle command alarms (B6A1 - B6A5)**

Alarm code	Name	Cause and corrective action
B6A1	No specified line No. in G70 - G73	<ol style="list-style-type: none"> <li>No specified line number is found in the cycle command.</li> <li>Check the G code and modify to the correct line number.</li> </ol>
B6A2	No line No. given by G70 - G73	<ol style="list-style-type: none"> <li>The cycle command did not specify the line number.</li> <li>Check the G code and add the correct line number.</li> </ol>
B6A3	Cycle command taper error	<ol style="list-style-type: none"> <li>The taper calculation of the thread cutting cycle command is in error.</li> <li>Modify the G code and check related parameters.</li> </ol>
B6A4	Chamfer command error	<ol style="list-style-type: none"> <li>The chamfer geometry dimension is incorrect.</li> <li>Modify the G code and check related parameters.</li> </ol>
B6A5	Illegal drilling / tapping	<ol style="list-style-type: none"> <li>Drilling / tapping cannot be executed.</li> <li>Check the G code and the C axis status.</li> </ol>

# Revision History

Release Date	Version	Chapter	Revision contents
June, 2021	V5.0	1.4	Added description for B series product models.
		2.2	Added description for B series product installation.
		3.1.11	<ol style="list-style-type: none"> <li>1. Added Remote I/O relay allowable current value.</li> <li>2. Added Remote I/O wiring diagram.</li> </ol>
		3.2	Added description for B series product wiring.
		4.4	Updated table of corresponding buttons for OPENCNC PC.
		12.4	Added second spindle parameter descriptions.
		12.5.1	Added rotation axis unit parameter descriptions.
		12.6.1	Updated parameter Pr616 return to Home mode.
		12.9.1	<ol style="list-style-type: none"> <li>1. Added parameter Pr10015 disable the function of automatically diving values with no decimal points by a thousand.</li> <li>2. Added description for parameter Pr10076 file queue settings.</li> </ol>
		12.10.1	<ol style="list-style-type: none"> <li>1. Added description for parameter PR12029 system/custom keyboard switching.</li> <li>2. Added description for parameter Pr12030 parameter customize keyboard button value.</li> </ol>
June, 2018	V4.0	3.2.1	Added NC3__ series MPG DI7/DI8 defined as X34/X35.
		3.10	Hardware modification after production serial number T1751, PIN (P8/P9) before T1751 is reserved.
		12.2.1	Added parameter Pr642 synchronous tolerance.
		12.6.1	Added Pr617 origin search setting bit 2 homing mode of rotation axis.
		12.6.1	Added home mode 7.
		12.9.1	Added open auxiliary input window.
		12.14.1	Modified details of RIO setting.
January, 2018	V3.0	All	NC__EM series updated to NC30E (H) series.
		3.1	Updated system interface and connector

Release Date	Version	Chapter	Revision contents
			descriptions.
		3.11	Updated text and added relay type (NC-EIO-R2010).
		12.6.1	Added description for origin search mode 6.
June, 2017	V2.0	3.12	Modified wiring diagram for local I/O connector (external power).
May, 2017	V1.0		

For relevant information about [Delta CNC Milling Machine Solution - Operation and Maintenance Manual], please refer to:

- (1) Delta CNC Milling Machine Solution Instruction Programming Manual
- (2) Delta CNC NC System Solution MLC Application Manual