



DELTA ELECTRONICS, INC.

www.delta.com.tw/industrialautomation

IABU Headquarters

Delta Electronics, Inc.
Taoyuan1
31-1, Xingbang Road, Guishan Industrial Zone,
Taoyuan County 33370, Taiwan, R.O.C.
TEL: 886-3-362-6301 / FAX: 886-3-362-7267

Asia

Delta Electronics (Jiang Su) Ltd.
Wujiang Plant3
1688 Jiangxing East Road,
Wujiang Economy Development Zone,
Wujiang City, Jiang Su Province,
People's Republic of China (Post code: 215200)
TEL: 86-512-6340-3008 / FAX: 86-512-6340-7290

Delta Greentech (China) Co., Ltd.
238 Min-Xia Road, Cao-Lu Industry Zone, Pudong, Shanghai,
People's Republic of China
Post code : 201209
TEL: 021-58635678 / FAX: 021-58630003

Delta Electronics (Japan), Inc.
Tokyo Office
Delta Shibadaimon Building, 2-1-14
Shibadaimon, Minato-Ku, Tokyo, 105-0012,
Japan
TEL: 81-3-5733-1111 / FAX: 81-3-5733-1211

Delta Electronics (Korea), Inc.
234-9, Duck Soo Building 7F, Nonhyun-Dong,
Kangnam-Gu, Seoul, Korea 135-010
TEL: 82-2-515-5305 / FAX: 82-2-515-5302

Delta Electronics (Singapore) Pte. Ltd.
8 Kaki Bukit Road 2, #04-18 Ruby Warehouse Complex,
Singapore 417841
TEL: 65-6747-5155 / FAX: 65-6744-9228

Delta Power Solutions (India) Pte. Ltd.
Plot No. 28, Sector-34, EHTP
Gurgaon-122001 Haryana, India
TEL: 91-124-416-9040 / FAX: 91-124-403-6045

AMERICA

Delta Products Corporation (USA)
Raleigh Office
P.O. Box 12173, 5101 Davis Drive,
Research Triangle Park, NC 27709, U.S.A.
TEL: 1-919-767-3813 / FAX: 1-919-767-3969

Delta Products Corporation (Brazil)
Sao Paulo Office
Rua Jardim Ivone, 17 Cjs 13/14-Paraiso
04105-020-Sao Paulo-SP-Brazil
TEL: 55-11-3568-3875 / FAX: 55-11-3568-3865

EUROPE

Deltronics (The Netherlands) B.V.
Eindhoven Office
De Witbogt 15, 5652 AG Eindhoven, The Netherlands
TEL: 31-40-2592850 / FAX: 31-40-2592851

DOP_W_EN_20110516

*We reserve the right to change the information in this manual without prior notice



DOP Series HMI Connection Manual



DOP Series HMI Connection Manual



www.delta.com.tw/industrialautomation

Delta Controller ASCII/RTU

HMI Factory Setting:

Baud rate: 9600, 7, None, 2 (ASCII); 9600, 8, None, 2 (RTU)

Controller Station Number: 1

Control Area / Status Area: None/None

Connection

Delta Servo





a. RS-232 (DOP-A/AE/AS, DOP-B Series)

DOP series		Controller
9 pin D-sub male (RS-232)		CN3 cable connector (RS-232)
RXD (2)	—————	(2) TX
TXD (3)	—————	(4) RX
GND (5)	—————	(1) GND





b. RS-422 (DOP-A/AE Series)

DOP series		Controller
9 pin D-sub male (RS-422)		CN3 cable connector (RS-422)
RXD- (1)	—————	(6) TX-
RXD+ (2)	—————	(5) TX+
TXD+ (3)	—————	(3) RX+
TXD- (4)	—————	(4) RX-



c. RS-422 (DOP-AS35/AS38/AS57 Series)

DOP series		Controller
9 pin D-sub male (RS-422)		CN3 cable connector (RS-422)
R-		(6) TX-
R+		(5) TX+
T+		(3) RX+
T-		(4) RX-

d. RS-422 (DOP-B Series)

DOP series		Controller
9 pin D-sub male (RS-422)		CN3 cable connector (RS-422)
RXD- (9)		(6) TX-
RXD+ (4)		(5) TX+
TXD+ (1)		(3) RX+
TXD- (6)		(4) RX-

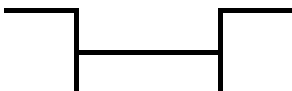
e. RS-485 (DOP-A/AE Series)

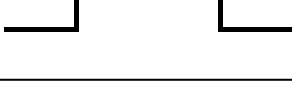
DOP series		Controller
9 pin D-sub male (RS-485)		CN3 cable connector (RS-485)
D+ (2)		(3) 485+
D+ (3)		(5) 485+
D- (1)		(4) 485-
D- (4)		(6) 485-

f. RS-485 (DOP-AS57 Series)

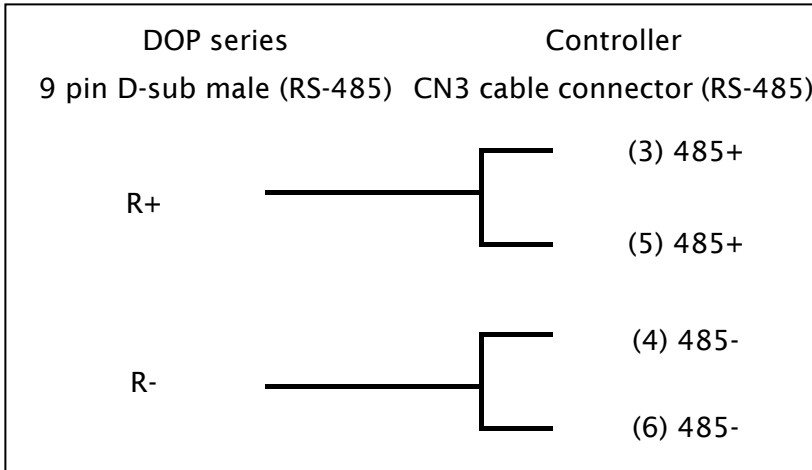

g. RS-485 (DOP-AS35/AS38 Series)

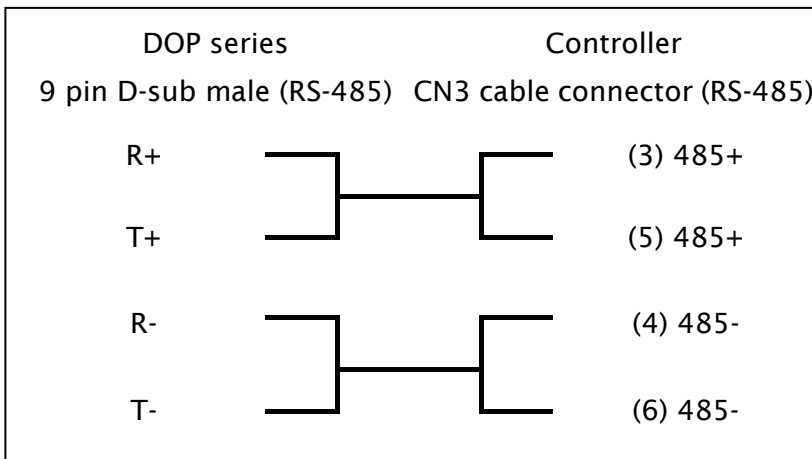

h. RS-485 (DOP-B Series)

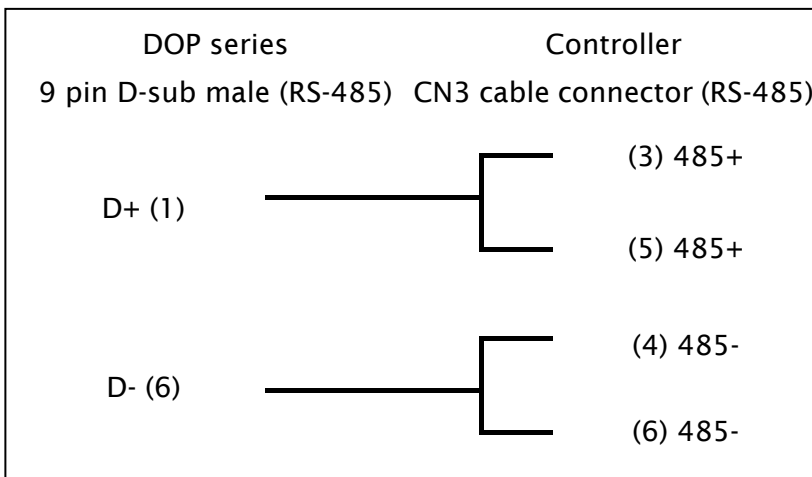

Delta AC Motor Drive

a. RS-485 (DOP-A/AE Series)

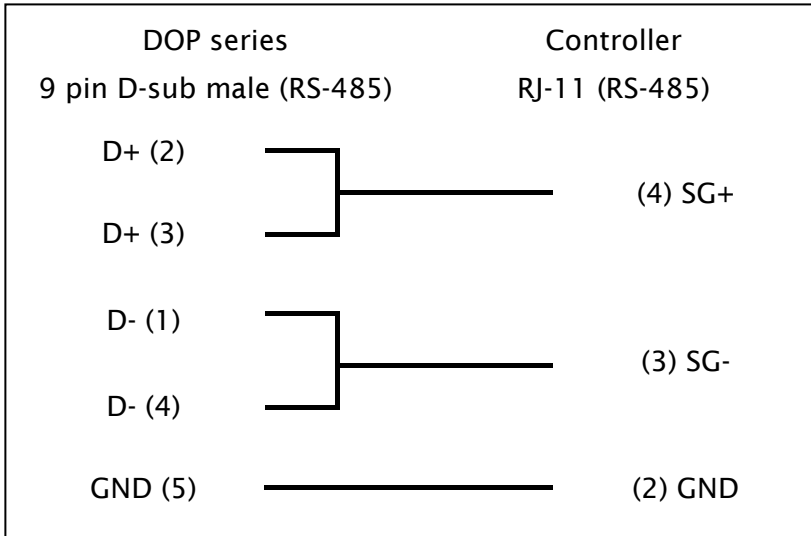

b. RS-485 (DOP-AS57 Series)

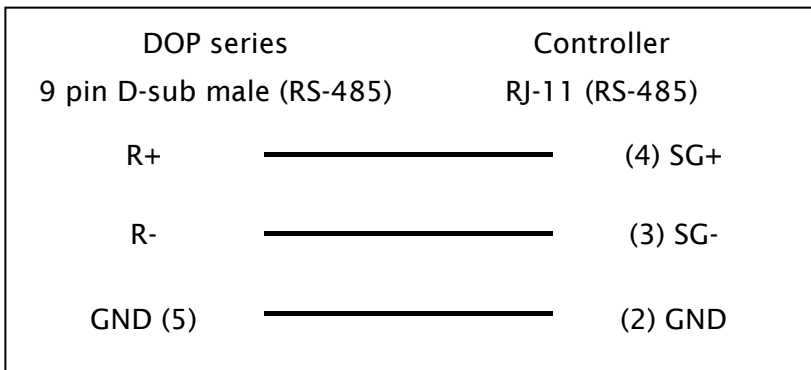

c. RS-485 (DOP-AS35/AS38 Series)

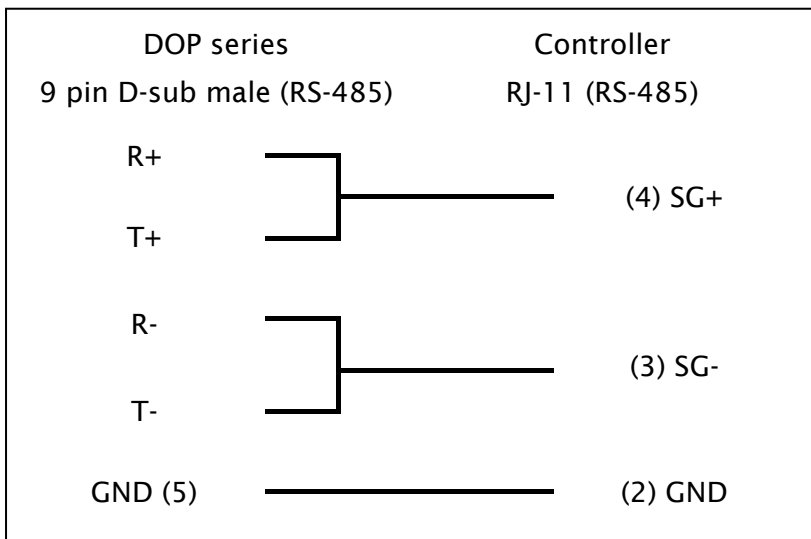

d. RS-485 (DOP-B Series)

DOP series		Controller
9 pin D-sub male (RS-485)		RJ-11 (RS-485)
D+(1)	—————	(4) SG+
D-(6)	—————	(3) SG-
GND (5)	—————	(2) GND

Temperature Controller

a. RS-485 (DOP-A/AE Series)

DOP series		Controller
9 pin D-sub male (RS-485)		RS-485 terminal
D+ (2)	┌───┐ └───┘	D+
D+ (3)		
D- (1)	┌───┐ └───┘	D-
D- (4)		

b. RS-485 (DOP-AS57 Series)

DOP series		Controller
9 pin D-sub male (RS-485)		RS-485 terminal
R+	—————	D+
R-	—————	D-

c. RS-485 (DOP-AS35/AS38 Series)

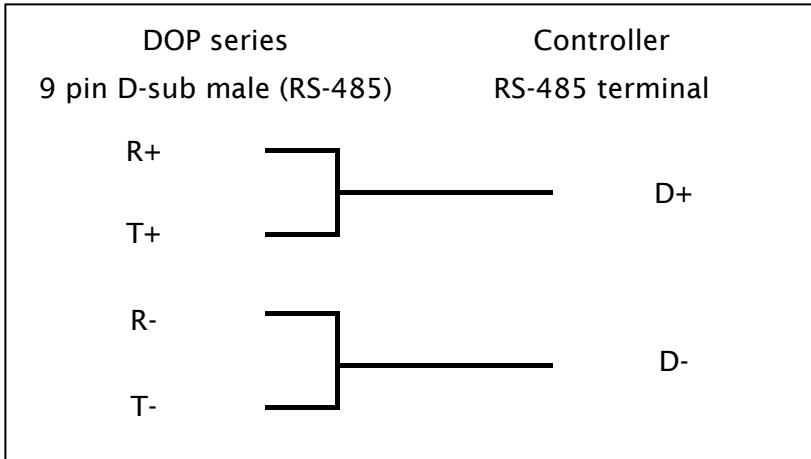

d. RS-485 (DOP-B Series)

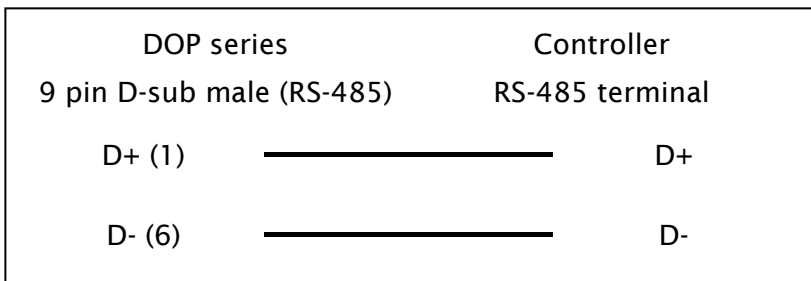

Definition of PLC Read/Write Address

a. Registers

Type	Format	Read/Write Range	Data Length	Note
	Word No. (n)			
Servo Communication Address	SERVO-n	SERVO-0 - SERVO-FFFF	Word	Hexadecimal
AC Drive Communication Address	INVERTER-n	INVERTER-0 - INVERTER-FFFF	Word	Hexadecimal
Temperature Controller Communication Address	TEMP_CTRL-n	TEMP_CTRL-0 - TEMP_CTRL-6000	Word	Hexadecimal
PLC Communication Address X	PLC_Xn	PLC_X0 - PLC_X360	Word	Octal, 1
PLC Communication Address Y	PLC_Yn	PLC_Y0 - PLC_Y360	Word	Octal, 1
PLC Communication Address M	PLC_Mn	PLC_M0 - PLC_M1520, PLC_M1536 - PLC_M4080	Word	1
PLC Communication Address S	PLC_Sn	PLC_S0 - PLC_S1008	Word	1

b. Contacts

Type	Format	Read/Write Range	Note
	Word No.(n) Bit No. (b)		
Servo Communication Address	SERVO-n.b	SERVO-0.0 – SERVO-FFFF.F	Hexadecimal
AC Drive Communication Address	INVERTER-n.b	INVERTER-0.0 – INVERTER-FFFF.F	Hexadecimal
Temperature Controller Communication Address	TEMP_CTRL-n. b	TEMP_CTRL-0.0 – TEMP_CTRL-6000.F	Hexadecimal
Servo Digital Input	SERVO_DI-b	SERVO_DI-1 – SERVO_DI-8	2
Servo Digital Output	SERVO_DO-b	SERVO_DO-1 – SERVO_DO-5	2
PLC Communication Address X	PLC_Xb	PLC_X0 – PLC_X377	Octal
PLC Communication Address Y	PLC_Yb	PLC_Y0 – PLC_Y377	Octal
PLC Communication Address M	PLC_Mb	PLC_M0 – PLC_M1535, PLC_M1536 – PLC_M4095	
PLC Communication Address S	PLC_Sb	PLC_S0 – PLC_S1023	
PLC Communication Address T	PLC_Tb	PLC_T0 – PLC_T255	
PLC Communication Address C	PLC_Cb	PLC_C0 – PLC_C255	
Temperature Controller Bit Communication Address	TEMP_CTRLB- b	TEMP_CTRLB-800 – TEMP_CTRLB-8FF	Hexadecimal
Discrete Outputs	RWB-b	RWB-0 – RWB-FFFF	Hexadecimal
Discrete Inputs	RB-b	RB-0 – RB-FFFF	Hexadecimal
Discrete Outputs	Bb	B1 – B10000	
Discrete Inputs	Bb	B10001 – B20000	

 **NOTE**

- 1) Device address must be the multiple of 16.
- 2) SERVO_DI-, SERVO_DO- are for Servo only ◦
- 3) HMI can be connected to several temperature controllers using RTU transmission mode. However a communication delay time of 5ms or longer is highly recommended.

Delta DVP PLC

HMI Factory Setting:

Baud Rate: 9600. 7. Even. 1

Controller Station Number: 1

Control Area / Status Area: D0/D10

Connection

a. RS-232 (DOP-A/AE/AS, DOP-B Series)

DOP series		Controller
9 pin D-sub male (RS-232)		8 pin Mini DIN male (RS-232)
RXD (2)	—————	(5) TXD
TXD (3)	—————	(4) RXD
GND (5)	—————	(8) GND

b. RS-485 (DOP-A/AE Series)

DOP series		Controller
9 pin D-sub male (RS-485)		RS-485 Terminal
D+ (2)	┌───┐ └───┘	D+
D+ (3)		
D- (1)	┌───┐ └───┘	D-
D- (4)		

c. RS-485 (DOP-AS57 Series)

DOP series		Controller
9 pin D-sub male (RS-485)		RS-485 Terminal
R+	—————	D+
R-	—————	D-

d. RS-485 (DOP-AS35/AS38 Series)

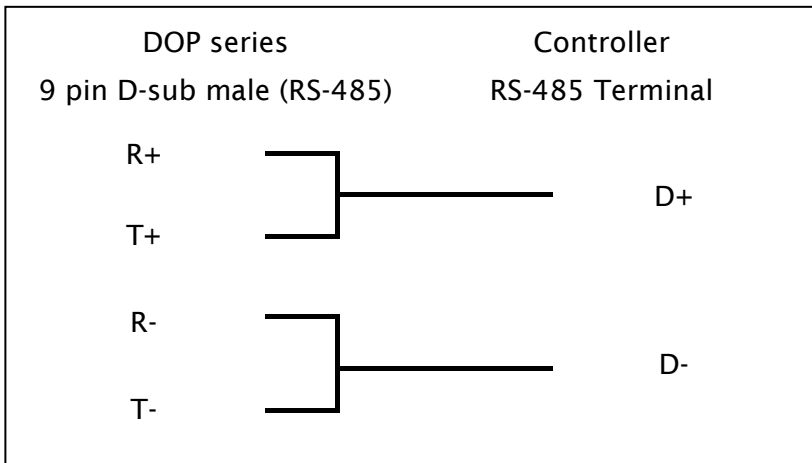

e. RS-485 (DOP-B Series)

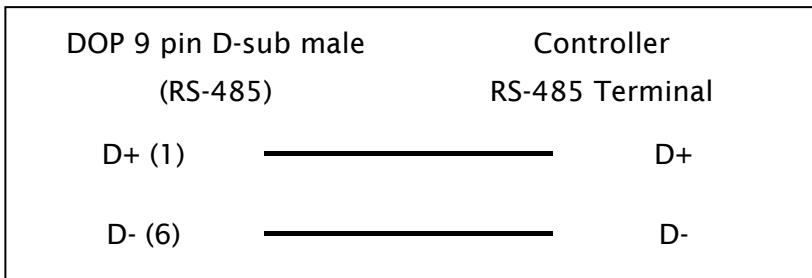

Definition of PLC Read/Write Address

a. Registers

Type	Format	Read/Write Range	Data Length	Note
	Word No. (n)			
X_Data	Xn	X0 - X360	Word	Octal, 1
Y_Data	Yn	Y0 - Y360	Word	Octal, 1
M_Data	Mn	M0 - M1520, M1536 - M4080	Word	1
S_Data	Sn	S0 - S1008	Word	1
T_Register	Tn	T0 - T255	Word	
C_Register	Cn	C0 - C199	Word	
D_Register	Dn	D0 - D9999	Word	
HC_Register	Cn	C200 - C255	Word	

b. Contacts

Type	Format	Read/Write Range	Note
	Bit No. (b)		
X_Data	Xb	X0 - X377	
Y_Data	Yb	Y0 - Y377	
M_Data	Mb	M0 - M4080	
S_Data	Sb	S0 - S1023	
T_Coil	Tb	T0 - T255	
C_Coil	Cb	C0 - C255	

 **NOTE**

- 1) Device address must be the multiple of 16.

Delta DVP TCP/IP

HMI Factory Setting:

Controller IP Address: 192.168.0.1
 Controller COM Port: 502
 Controller Station Number: 1
 Control Area / Status Area: D0/D10

Connection

Standard Jumper Cable / Network Cable without jumper (Auto-detected by HMI)

Definition of PLC Read/Write Address

a. Registers

Type	Format	Read/Write Range	Data Length	Note
	Word No. (n)			
X_Data	Xn	X0 - X360	Word	Octal, 1
Y_Data	Yn	Y0 - Y360	Word	Octal, 1
M_Data	Mn	M0 - M1520, M1536 - M4080	Word	1
S_Data	Sn	S0 - S1008	Word	1
T_Register	Tn	T0 - T255	Word	
C_Register	Cn	C0 - C199	Word	
D_Register	Dn	D0 - D9999	Word	
HC_Register	Cn	C200 - C255	Word	

b. Contacts

Type	Format	Read/Write Range	Note
	Bit No. (b)		
X_Data	Xb	X0 - X377	
Y_Data	Yb	Y0 - Y377	
M_Data	Mb	M0 - M4080	
S_Data	Sb	S0 - S1023	
T_Coil	Tb	T0 - T255	

Type	Format	Read/Write Range	Note
	Bit No. (b)		
C_Coil	Cb	C0 - C255	

 **NOTE**

- 1) Device address must be a multiple of 16

Delta RTU-EN01 (Modbus TCP)

HMI Factory Setting:

Controller IP Address: 192.168.0.1

Controller COM Port: 502

Controller Station Number: 1

Control Area / Status Area: None/None

Connection

Standard Jumper Cable / Network Cable without jumper (Auto-detected by HMI)

Definition of PLC Read/Write Address

a. Registers

Type	Format	Read/Write Range	Data Length	Note
	Word No. (n)			
Basic Register	BR-n	BR-0 - BR-63	Word	Read only
Timer Register	T-n	T-0 - T-15	Word	
Counter Register	C-n	C-0 - C-15	Word	
I/O Module Control Register	RCR-n	RCR-0 - RCR-399	Word	

b. Contacts

Type	Format	Read/Write Range	Note
	Bit No. (b)		
Input Relay	RX-b	RX-0 - RX-255	Read only
Output Relay	RY-b	RY-0 - RY-255	
Timer Relay	T-b	T-0 - T-15	
R Relay	R-b	R-0 - R-15	
Counter Relay	C-b	C-0 - C-15	

 **NOTE**

- 1) The address number can be up to three digits. Even if leading 0 (zero) is used, the total address number should not be more than three digits.
- 2) Relationship between Modbus address and HMI register:

Delta RTU-EN01 (Modbus TCP) Address		Modbus Address (Dec)
Basic Register	BR-0 - BR-63	W400001 - W400064
Timer Register	T-0 - T-15	W405633 - W405648
Counter Register	C-0 - C-15	W407681 - W407696
I/O Module Control Register	RCR-0 - RCR-399	W412289 - W412689
Input Relay	RX-0 - RX-255	B101025 - B101280
Output Relay	RY-0 - RY-255	B001281 - B001536
Timer Relay	T-0 - T-15	B005633 - B005648
R Relay	R-0 - R-15	B006401 - B006416
Counter Relay	C-0 - C-15	B007681 - B007696

Delta Solectria Inverter

HMI Factory Setting:

Baud Rate: 19200. 8. None. 1

Controller Station Number: 1

Control Area / Status Area: None/ None

Connection

a. RS-232 (DOP-A/AE/AS, DOP-B Series)

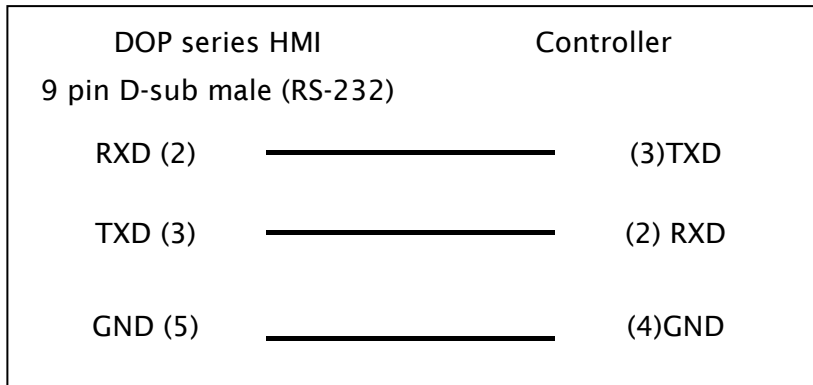

b. RS-485 (DOP-A/AE Series)

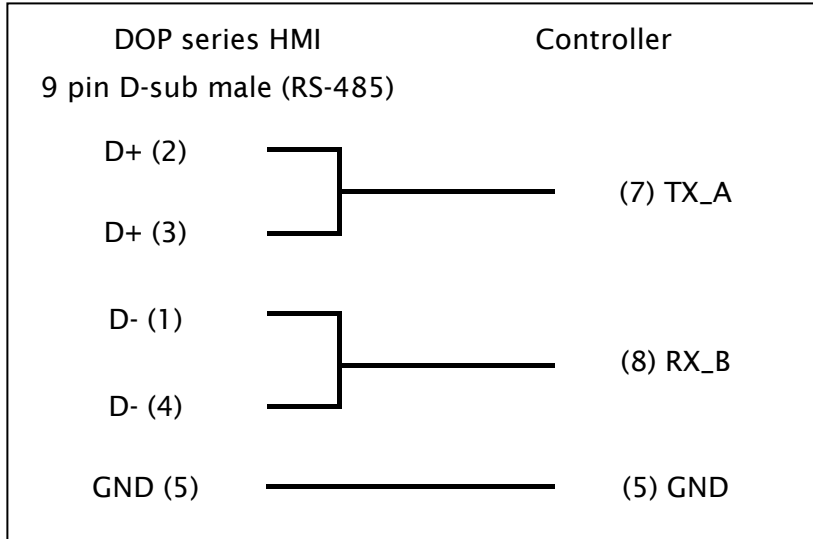

c. RS-485 (DOP-AS57 Series)

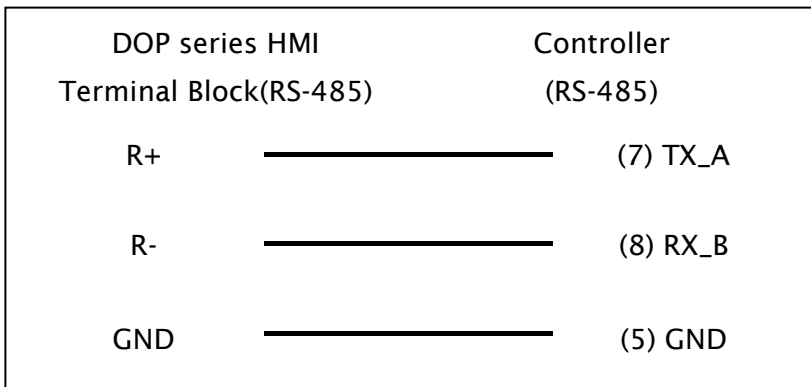

d. RS-485 (DOP-AS35/AS38 Series)

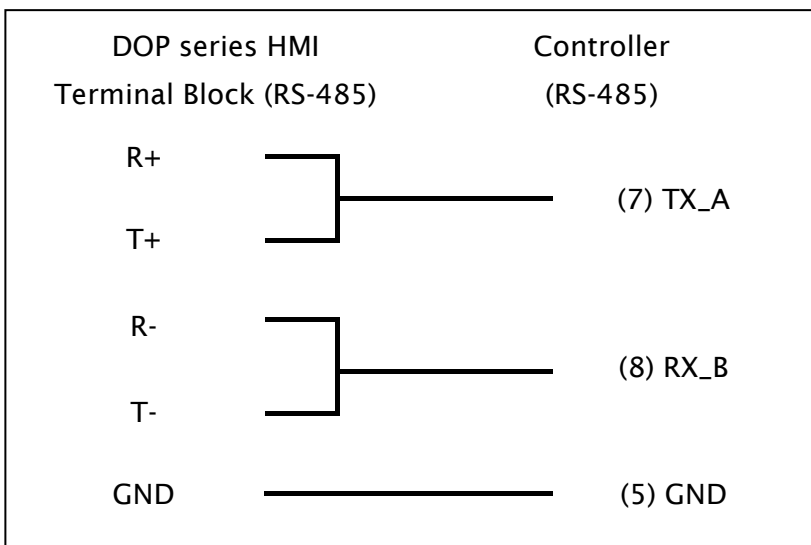

e. RS-485 (DOP-B Series)

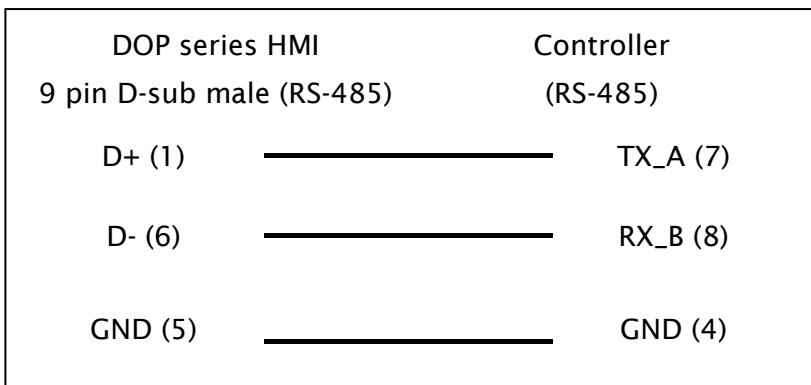

Definition of PLC Read/Write Address

a. Registers

Type	Format	Read/Write Range	Data Length	Note
	command(n) sub-command(m)			
Command Group	CMDBn:m	CMDB1:1 - CMDB255:127	Byte	
Command Group	CMDWn:m	CMDW1:1 - CMDW255:127	Word	
Command Group	CMDDn:m	CMDD1:1 - CMDD255:127	Double Word	

b. Contacts

Type	Format	Read/Write Range	Note
	Command(n) Sub-Command(m) Bit No.(b)		
Command Group	CMDBn:m/b	CMDB1:1/0 - CMDB255:127/7	
Reset Group Data	RSTb	RST1 - RST255	

 **NOTE**

- 1) Device address indicates the function code provided by controller, “n” represent command and “m” represent sub-command. The suffix of CMD represent the data length (B/W/D = Byte/Word/Double word). Please refer to Delta PLC user manual for the function code and select the corresponding data length. For example, to access function 12:01 select CMDB; and to access function 22:03 select CMDD.
- 2) The address of CMDB indicates certain bit of the function code when the data length for read/write is byte. RST is the sub command of Reset. The address of RST indicates the reset function code. For example, RST23 represents the function code 23, i.e. 128 (reset statistic) function.
- 3) Sub-command 0 usually supports the access to all data in the command group, but in this case it does not support the access since the required data length is not fixed. For the same reason, command 0 is not supported as well.
- 4) Since every function is independent, it does not support read “optimized” function.
- 5) Data length should set according to the function code since the require setting differ among each function. If CMDB or CMDW is selected, data length setting should be Word; if CMDD is selected, data length setting should be Double Word. For example, data length setting for CMDW12:05 must be Word otherwise error may occur.